

TRANSPORTATION & LOW VOLTAGE
miniature
and Sealed Beam
L A M P • C A T A L O G



GE Lighting



Table of Contents

Introduction	2
Finding a lamp	2
Ordering	2
Formulas	2
Abbreviations	2
GE Miniature Lamp Prefixes	2
GE Miniature Lamp Suffixes	2
Important Notice	3
Glossary of Headings	3
Lamp Locator	4
Numerical Index	5-18
Miniature	5-14
Neon Glow	14
Sealed Beam	14-18
European Automotive Cross Reference	18
Halogen Cycle Lamps Information	19
Design Features	19
Miniature Lamps Design Features	20-21
Filaments & Bases	22
Specifications	23-41
Central Discharge Lamps Specifications	41
Neon Glow Lamps Specifications	42
Festoon Type, Auto & Special Service Lamps Specifications	42
Sealed Beam Lamps Bulbs, Filaments, & Bases	43
Specifications	44-49
Safety Notes	50
International Sales Offices	51
U.S. Sales Offices	Back Cover

The Quality Vision

It is the goal of GE lighting to be the world leader in quality - without exception. We can attain this goal by manufacturing and delivering products and services that faithfully conform to our specifications and satisfy the needs and expectations of our customers. Accordingly, we commit ourselves to expect, achieve and accept only those things that are done with excellence.

INTRODUCTION

GE sealed beam and miniature lamps are designed for those applications requiring specific size, long life, and a competitive cost. These lamps are available with a wide variety of filament constructions, bases and wire terminal leads. Most are designed for operation on low-voltage power sources such as battery-generator systems, dry cell or storage batteries, or transformers. Manufacturers and designers of equipment requiring lamps should select lamps of established design whenever possible for maximum economy as well as ease of replacement through regular trade channels.

Finding a lamp

In this catalog, lamps are listed two ways for quick reference. The index lists lamps numerically on pages 5-18. The final section, pages 23-49, groups lamps alphabetically "B" to "T", by bulb size. Lamps are listed in ascending order of design volts within the particular group.

Ordering

Use the order code located in the left columns of the index on pages 5-18 or 23-49. Be sure to order from the correct quantity column, i.e. blister pack, unit pack, bulk pack. Miniature unit packs come in quantities of 10-50 lamps. Sealed beam unit package quantities are 6-12. Bulk standard package quantity is provided to simplify ordering. See Sales Offices for specific information.

Formulas

The following are commonly used formulas to assist any calculations you may need. For further information, contact your GE Lamp Representative.

- Watts = Volts x Amps
- Kelvin = Celsius + 273
- Lumens = 12.57 x Mean Spherical Candlepower
- Footcandles = Candlepower/Distance squared (miniature lamps only)
- Hot Resistance (Ohms) = Volts/Amps

Abbreviations

The abbreviations used in this catalog include:

A Amperes	Flg. Flanged	Sc. Screw
ANSI American National Standards Institute	HID High Intensity Discharge	S.C. Single Contact
Bay. Bayonet	HIR Halogen Infrared	Spec. Special
C.I.M. Construction & Industrial Machinery	LCL Light Center Length	Tel. Telephone
C.P. Candlepower	Min. Miniature	Term. Terminals
Cand. Candelabra	MOL Maximum Overall Length	V Volts
D.C. Double Contact	MSCP Mean Spherical Candlepower	W Watts
ECE European Common Market (European Motor Vehicle Standards)	Nom. Nominal	
	PAR Parabolic Aluminized Reflector	
	Pf. Prefocus	
	SAE Society of Automotive Engineers (US Motor Vehicle Standards)	

GE Miniature Lamp Prefixes

DE Double Ended	PR Prefocus Base (E.G., "Flashlight Lamp")
H Halogen	Q Quartz Halogen
K Krypton Gas	SE Single Ended
PC Printed Circuit Application	W,T,R,C,P European Designation

GE Miniature Lamp Suffixes

A Amber	NA Natural Amber (automotive lighting)
AF All Frost (on outside)	PSB Pilot Indicator/Short Base
AS10 Ages and Selected (for candlepower)	R Red
B Blue	SB Silver Bowl (all or some portion of bulb is silver)
C1 Refers to a range of current on telephone lamps (A1, B1, D1, E1, etc. used also)	TY Letters after a quartz halogen lamp mean a deviation from the standard lamp - usually refers to the electrical terminals
CW Cool White (aircraft lighting)	U Lead wires up or no base, e.g., unbased sealed beam lamp
D Lead Wires Down	WW Warm White (aircraft lighting)
E Extended Lead Wires	X Indicates some arbitrary deviation from the normal product
E-1 Different lead wire material (NI plated)	Y Yellow
G Green	-1 Slip on terminals
HD Heavy Duty	-2 Represents various deviations
HIR Halogen Infrared	-3 Represents deviations (e.g. combination terminal)
HO High Output	W European Designation (Watts)
K Unique Base	
KR Krypton Fill	
L, XL, LL Long Life	
MB Miniature Bayonet	

Important Notice

This catalog contains accumulated data to March 2003. Additional information is constantly being uncovered through research and testing, which may modify the data given herein. This is particularly true of newer lamps. Accordingly, SPECIFICATIONS ARE SUBJECT TO CHANGE WITHOUT NOTICE. For the latest lamp design data and information, contact your GE Lamp Representative.

The data and suggested applications contained in this catalog, as well as any additional information our representative may be able to furnish, are for general information only and are not intended and should not be taken as representations or warranties as to the suitability of a lamp for any particular application or use in any particular equipment, nor are our representatives authorized to make any such warranties. Applications and conditions of use are many and varied, and beyond our control. We cannot possibly have the same degree of knowledge that the purchaser has with respect to the design of his equipment and the conditions of its use. Therefore, it is up to the purchaser to make his own determination as to the suitability of a lamp for his intended application or use and to assume the responsibility for that determination.

General Electric desires to supply the best possible products at all times. For this reason, General Electric reserves the right to make changes in its products, and to introduce new lamps or discontinue existing ones without notice.

Glossary of Headings

The following glossary of terms can help you when checking lamp specifications and when ordering products.

Approximate Total Spread to 10% Maximum Candlepower: Beam size expressed in degrees vertical and horizontal.

Atmosphere: Indicates whether the lamp is gas filled or vacuum. Gas filled lamps are more efficient than vacuum lamps.

Average Cold Resistance: The average resistance of an unburned lamp.

Base: Bases provide electrical contact to the lamp and, in most cases, also support the lamp in the fixture. (Complete diagrams of miniature bases are located on page 22. Sealed beam base diagrams can be found on page 43.)

Bulb: The prefix letter refers to the bulb shape, and the number is the approximate diameter in eighths of an inch. For example T-2 means approximately $\frac{2}{8}$ th inch or $\frac{1}{4}$ " diameter.

Circuit Volts AC or DC: The operational voltage range.

Design End Foot Candles: The measure of the portion of the total light output of a T-2 lamp that passes through a .250" orifice placed at the end of the lamp.

Design Volts: Voltage at which the lamp is designed to provide the amperes, candlepower and laboratory life characteristics.

Design Watts or Amps: The power consumption (watts) or current rating (amps) at the design voltage. In the case of dual-filament lamps, the values for each filament are given.

Figure Number: Corresponds to the lamp drawing. The drawing shows the correct bulb and base; but not the filament, for the lamp listed.

Filament Designation: Filaments may be straight wire (S), a coil (C) or a coiled coil (CC). The number denotes the arrangement of the filament on the supports. Complete diagrams of miniature filaments are located on page 22. Sealed beam filament diagrams can be found on page 43.

Initial Maximum Beam Candlepower: The maximum light intensity at a point in the beam.

Lamp Number: In nearly all cases lamps are marked with a General Electric Trade Number recorded with the American National Standards Institute. See glossary of prefixes and suffixes on page 2.

Light Center Length: Indicates the location of the filament with reference to the lamp base. The LCL is measured from the geometric center of the light source to a particular point of the base. This point is shown on the lamp drawing.

Line Number: Line number on specified page where the lamp can be found.

Maximum Overall Length: The dimension which includes the bulb and base is designated as the overall length of the lamp. In the case of wire terminal lamps, this dimension applies only to the glass portion.

Mean Spherical Candlepower: Initial mean spherical candlepower at the design voltage. Mean spherical candlepower is the generally accepted method of rating the total light output of miniature lamps. To convert this rating to lumens, multiply it by 12.57 (4 pi).

Nominal Current: This is the average expected current.

Nominal Watts: This is the average expected watts.

Order code: Use this code when ordering to ensure that you receive the exact product you require.

Page Number: Page number on which further specifications/illustrations can be found.

Primary Application: Current major uses of lamp. Lamps may be and are used in many other applications where their designs will permit. This column also lists any unique features of the lamp.

Rated Average Lab Life: Rated average life is that obtained in closely controlled laboratory testing of lamps at their design voltage. It is not necessarily the same as service life; shocks, vibration, voltage fluctuations, temperature, and other environmental influences may result in a shorter service life.

SAE Specifications: Specifications for headlamps (forward lighting) can be found in a SAE Ground Vehicle Lighting Standards Manual SAE HS-34. There are numerous test points in the beam patterns for headlamps in conjunction with minimum and maximum photometry values. Space does not permit these many test points to be included in the light distribution column. Please contact your GE Representative for more detailed information.

Series Resistance: In order to properly control the neon glow lamp current, a ballast resistor must be used. Lamps having screw bases have the necessary resistor built-in. Those having bayonet bases do not have a built in resistor. The tables show the value of the external resistor to be used for normal operation at indicated circuit volts, or the value of the built-in resistor where applicable.

LAMP LOCATOR

The lamps listed here are not to scale. To determine the diameter of a bulb in inches, multiply the bulb number by one-eighth. For example T-2 means approximately $\frac{2}{8}$ " or $\frac{1}{4}$ " diameter.

Bulb	Page	Bulb	Page	Bulb	Page	Bulb	Page
B-3 $\frac{1}{2}$	23	S-8	26-30	TL-2 $\frac{3}{4}$	33	T-4	38
B-6	23	S-11	30	T-3	33-34	T-4 $\frac{1}{2}$	38
G-3 $\frac{1}{2}$	23-24	T-1	31	TL-3	34	T-4 $\frac{3}{4}$	38-39
G-4 $\frac{1}{2}$	24	T-1 $\frac{3}{4}$	31	T-3 $\frac{1}{4}$	34-37	T-5	39-40
G-5	24	T-2	31	T-8	40	T-7	40
G-6	25	T-2 $\frac{1}{4}$	31-32	Elec. Discharge	41	T-5	41
R-12	26	T-2 $\frac{1}{2}$	32	Central Discharge	41	Neon Glow	42
RP-11	26	T-2 $\frac{3}{4}$	32	TL-3 $\frac{1}{4}$	37	Festoon Type	42

Sealed Beam drawings can be found on page 43

INDEX – MINIATURE LAMPS

Order Code			Bulk Std. Pkg. Qty.	Lamp No.	Bulb	Base	Design		Mean Spherical Candlepower (Approx.)	Rated Avg. Lab Life (Hours)	Page No.	Line No.
Blister Pack	Unit Pack	Bulk Pack					Volts	Watts or Amps				
				6PSB	T-2	Tel. Slide #5	6.0	.14A	—	20,000	31	19
				10	G-3 1/2	Miniature Two Pin	2.50	.50A	.5	3,000	23	22
				12	G-3 1/2	Miniature Two Pin	6.30	.15A	.35	5,000	23	24
				12PSB	T-2	Tel. Slide #5	12.0	.17A	—	12,000	31	20
				13	G-3 1/2	Miniature Screw	3.70	.30A	.98	15	23	23
				14	G-3 1/2	Miniature Screw	2.47	.30A	.5	15	23	21
				15	G-4 1/2	Miniature Two Pin	7.0	.40A	2	500	24	10
				19	G-3 1/2	Miniature Two Pin	14.40	.10A	.9	1,000	23	27
12325		25379	1000	24	T-2 3/4	Wedge	14.0	.24A	2	1,500	32	21
				24E2	T-2	Tel. Slide #3	24.0	.035A	—	7,000	31	21
12316				24NA	T-2 3/4	Wedge	14.0	.24A	1.5	1,500	32	22
				24PSB	T-2	Tel. Slide #5	24.0	.073A	—	10,000	31	22
				27	G-4 1/2	Miniature Screw	4.9	.30A	1.4	30	24	6
				28MB	T-2 1/2	Miniature Bayonet	28.0	.04A	.29	5,000	32	12
				28PSB	T-2	Tel. Slide #5	28.0	.04A	—	5,000	31	23
26480		13689	4000	37	T-1 3/4	Wedge	14.0	.09A	.5	2,500	31	9
				43	T-3 1/4	Miniature Bayonet	2.5	.50A	.5	3,000	34	8
				44	T-3 1/4	Miniature Bayonet	6.3	.25A	.9	3,000	34	16
				47	T-3 1/4	Miniature Bayonet	6.3	.15A	.52	3,000	34	12
				48C2	T-2	Tel. Slide #3	48.0	.035A	—	5,000	31	24
				48PSB	T-2	Tel. Slide #5	48.0	.05A	—	10,000	31	25
				51	G-3 1/2	Miniature Bayonet	7.50	.22A	1	1,000	23	25
				53	G-3 1/2	Miniature Bayonet	14.4	.12A	1	1,000	24	1
				55	G-4 1/2	Miniature Bayonet	7.0	.41A	2	500	24	11
23218		25593	4000	57	G-4 1/2	Miniature Bayonet	14.0	.24A	2	500	24	12
				60MB	T-2 1/2	Miniature Bayonet	60.0	.05A	.73	7,500	32	13
				60PSB	T-2	Tel. Slide #5	60.0	.05A	—	7,500	31	26
12321				63	G-6	S.C. Bayonet	7.0	.63A	3	1,000	25	4
				64	G-6	D.C. Bayonet	7.0	.63A	3	1,000	25	5
12324		25654	1000	67	G-6	S.C. Bayonet	13.5	.59A	4	5,000	25	10
				68	G-6	D.C. Bayonet	13.5	.59A	4	5,000	25	11
				70	T-1 3/4	Wedge	14.0	.15A	1.5	100	31	11
23015		39218	4000	73	T-1 3/4	Wedge	14.0	.08A	.3	15,000	31	5
21029		38457	4000	74	T-1 3/4	Wedge	14.0	.10A	.7	1,000	31	10
				81	G-6	S.C. Bayonet	6.5	1.02A	6	500	25	2
				82	G-6	D.C. Bayonet	6.5	1.02A	6	500	25	3
				85	T-1 3/4	Wedge	28.0	.04A	.3	7,000	31	12
				86	T-1 3/4	Wedge	6.3	.20A	.4	20,000	31	3
				88	S-8	D.C. Bayonet	6.8	1.91A	15	300	27	9
12363		25778	18618	89	G-6	S.C. Bayonet	13.0	.58A	6	750	25	6
47797				89KR*	G-6	S.C. Bayonet	13.0	.58A	6	1,500	25	7
12364		25794	25796	90	G-6	D.C. Bayonet	13.0	.58A	6	750	25	8
23217		25811	25813	93	S-8	S.C. Bayonet	12.8	1.04A	15	700	27	11
				94	S-8	D.C. Bayonet	12.8	1.04A	15	700	27	12
12322		25836	25838	97	G-6	S.C. Bayonet	13.5	.69A	4	5,000	25	13
				98	G-6	S.C. Bayonet	13.0	.62A	6	800	25	9
				105	B-6	S.C. Bayonet	12.8	1.00A	12	500	23	18
				112	TL-3	Miniature Screw	1.2	.22A	—	5	34	5
				120MB	T-2 1/2	Miniature Bayonet	120.0	.025A	.36	7,500	32	14
				120PSB	T-2	Tel. Slide #5	120.0	.025A	—	7,500	31	27
				147	T-3 1/4	Wedge	7.0	.43A	2	1,500	34	20
				149	T-3 1/4	Wedge	6.15	.53A	3.5	15	34	11
				157	G-6	Miniature Screw	5.8	1.10A	8.1	50	25	1
				158	T-3 1/4	Wedge	14.0	.24A	2	500	36	3
23016		25956	16489	161	T-3 1/4	Wedge	14.0	.19A	1	4,000	35	28

*New lamp added since last publication. Turquoise-Halogen Lamps

INDEX – MINIATURE LAMPS

Order Code			Bulk Std. Pkg. Qty.	Lamp No.	Bulb	Base	Design		Mean Spherical Candlepower (Approx.)	Rated Avg. Lab Life (Hours)	Page No.	Line No.
Blister Pack	Unit Pack	Bulk Pack					Volts	Watts or Amps				
12327	25962	16302	4000	168	T-3/4	Wedge	14.0	.35A	3	1,500	36	19
47827				168XL*	T-3/4	Wedge	14.0	.35A	3	3,000	36	20
	19553	19852	4000	193	T-3/4	Wedge	14.0	.33A	2	15,000	36	15
		19921	4000	193E	T-3/4	Wedge, Wire Terminal	14.0	.33A	2	15,000	36	16
		11807	4000	193E-1	T-3/4	Wedge, Wire Terminal	14.0	.33A	2	15,000	36	17
12328	25965	16303	4000	194	T-3/4	Wedge	14.0	.27A	2	2,500	36	6
12356				194B	T-3/4	Wedge	14.0	.27A	2	2,500	36	7
12357				194G	T-3/4	Wedge	14.0	.27A	2	2,500	36	8
12319	44859	27470	4000	194NA	T-3/4	Wedge	14.0	.27A	1.5	2,500	36	9
47794				194NAXL*	T-3/4	Wedge	14.0	.27A	1.5	5,000	36	10
12355		21618	4000	194R	T-3/4	Wedge	14.0	.27A	2	2,500	36	11
25832				194XL	T-3/4	Wedge	14.0	.27A	2	12,000	36	12
	37983	37984	500	198	S-8	D.C. Index	12.8	2.25A	32	1,200	29	7
							14.0	.59A	3	5,000		
	37985	37986	500	199	S-8	S.C. Bayonet	12.8	2.25A	32	1,200	29	8
	25988			210	B-6	D.C. Bayonet	6.5	1.78A	15	100	23	14
12673	39224	11803	1000	211-2	T-3	Miniature Cap	12.8	.97A	12	1,000	33	12
23220		11806	1000	212-2	T-3	Miniature Cap	13.5	.74A	6	2,000	33	18
40135	39356	11804	1000	214-2	T-3	Miniature Cap	13.5	.52A	4	1,000	33	16
	26008			222	TL-3	Miniature Screw	2.25	.25A	—	5	34	6
	26063			243	TL-3	Miniature Screw	2.33	.27A	—	10	34	7
	26095			258	G-4 1/2	Miniature Screw	14.0	.27A	1.6	500	24	13
	26099			259	T-3/4	Wedge	6.3	.25A	.65	5,000	34	17
	44719			265	G-3 1/2	Miniature Bayonet	28.0	.08A	.75	5,000	24	4
	42758			267	T-3/4	Miniature Bayonet	6.3	.15A	.33	5,000	34	13
	32688			293	G-4 1/2	Miniature Bayonet	14.0	.33A	2	7,500	24	15
	26112			301	G-5	S.C. Bayonet	28.0	.17A	3	500	24	18
	26120			302	G-5	D.C. Bayonet	28.0	.17A	3	500	24	19
	26127			303	G-6	S.C. Bayonet	28.0	.30A	6	500	25	20
	26136			304	G-6	D.C. Bayonet	28.0	.30A	6	500	25	21
	26143			305	S-8	S.C. Bayonet	28.0	.51A	15	300	29	16
	26145			305AF	S-8	S.C. Bayonet	28.0	.51A	—	300	29	17
	26152			306	S-8	D.C. Bayonet	28.0	.51A	15	300	29	18
	26157			307	S-8	S.C. Bayonet	28.0	.67A	21	300	30	5
	26161			307AF	S-8	S.C. Bayonet	28.0	.67A	21	300	30	6
	26168			308	S-8	D.C. Bayonet	28.0	.67A	21	300	30	7
	26171			308AF	S-8	D.C. Bayonet	28.0	.67A	—	300	30	8
	26175			309	S-11	S.C. Bayonet	28.0	.90A	32	300	30	22
	26191			311	S-11	S.C. Bayonet	28.0	1.29A	50	300	30	23
	26212	26214	4000	313	T-3/4	Miniature Bayonet	28.0	.17A	3.5	500	37	4
	26238			315	S-8	S.C. Bayonet	28.0	.90A	32	300	30	13
	26243			316	T-3/4	Miniature Bayonet	6.0	.70A	3.4	500	34	10
	28519			327	T-1 1/4	S.C. Midget Flanged	28.0	.04A	.34	4,000	31	13
	28546			328	T-1 1/4	S.C. Midget Flanged	6.0	.20A	.34	1,000	31	2
	28567			330	T-1 1/4	S.C. Midget Flanged	14.0	.08A	.5	1,500	31	6
	28588			334	T-1 1/4	Midget Grooved	28.0	.04A	.34	4,000	31	14
	26255			356	G-3 1/2	Miniature Bayonet	28.0	.17A	3.5	500	24	5
	28653			381	T-1 1/4	S.C. Midget Flanged	6.3	.20A	.4	20,000	31	4
	28657			382	T-1 1/4	S.C. Midget Flanged	14.0	.08A	.3	40,000	31	7
	28660			385	T-1 1/4	S.C. Midget Flanged	28.0	.04A	.15	10,000	31	15
	28662			386	T-1 1/4	Midget Grooved	14.0	.08A	.3	40,000	31	8
	28664			387	T-1 1/4	S.C. Midget Flanged	28.0	.04A	.3	7,000	31	16
	28672			388	T-1 1/4	Midget Grooved	28.0	.04A	.3	7,000	31	17
	38918			400	T-3/4	Wedge	28.0	.10A	1.6	1,000	37	2
	26354			425	G-4 1/2	Miniature Screw	5.0	.50A	2.3	15	24	7

*New lamp added since last publication. **Turquoise—Halogen Lamps**

INDEX – MINIATURE LAMPS

Order Code			Bulk Std. Pkg. Qty.	Lamp No.	Bulb	Base	Design		Mean Spherical Candlepower (Approx.)	Rated Avg. Lab Life (Hours)	Page No.	Line No.
Blister Pack	Unit Pack	Bulk Pack					Volts	Watts or Amps				
	26441			456	G-4 1/2	Miniature Bayonet	28.0	.17A	2	5,000	24	16
	39645			464	T-3 1/4	Wedge	28.0	.17A	3	1,500	37	5
	26460			502	G-4 1/2	Miniature Screw	5.1	.15A	.6	100	24	8
	26485			509K	G-6	Candelabra Screw	24.0	.18A	2.8	1,000	25	17
	44773	44774	4000	555	T-3 1/4	Wedge	6.3	.25A	.9	3,000	34	18
	38269			558	TL-3 3/4	Wedge	13.0	.33A	—	500	37	11
12358	39746	11820	1000	561	T-3	Rigid Loop	12.8	.97A	12	1,000	33	13
23019		11822	1000	562	T-3	Rigid Loop	13.5	.74A	6	2,000	33	19
26205		11825	1000	563	T-3	Rigid Loop	13.5	.52A	4	1,000	33	17
12672				570	T-4 3/4	Rigid Loop	12.8	2.10A	32	600	38	18
23020				577	T-4 3/4	Double End Cap	12.8	1.40A	21	1,000	38	17
	18442	18439	4000	590	T-3 1/4	Wedge	13.5	.37A	4	2,000	35	23
	25199	25200	4000	591	T-3 1/4	Wedge	14.0	.24A	2	3,000	36	4
	26549			605	G-4 1/2	Miniature Screw	6.15	.50A	3.4	15	24	9
	26561	26563	1000	623	G-6	S.C. Bayonet	28.0	.37A	6	1,000	25	22
	26567	26568	1000	624	G-6	D.C. Bayonet	28.0	.37A	6	1,000	25	23
23023	26570			631	G-6	S.C. Bayonet	14.0	.63A	6	1,000	25	16
	38866			656	T-3 1/4	Wedge	28.0	.06A	.62	2,500	36	28
	38196			657	T-3 1/4	Wedge	28.0	.08A	.62	15,000	36	30
	39999	40000	4000	658	T-3 1/4	Wedge	14.0	.08A	0.31	15,000	35	26
		28706	1000	685	T-1	Sub-Midget Flanged	5.0	.06A	.05	40,000	31	1
	43132			705	S-8	S.C. Bayonet	28.0	.51A	15	900	29	19
	26591			755	T-3 1/4	Miniature Bayonet	6.3	.15A	.33	20,000	34	14
	26593			756	T-3 1/4	Miniature Bayonet	14.0	.08A	.31	15,000	35	27
	26599			757	T-3 1/4	Miniature Bayonet	28.0	.08A	.62	15,000	37	1
	11014			767	T-2 1/4	Miniature Bayonet	6.0	2.00A	19	50	32	1
	11250			773	T-2 3/4	G-4 Two Pin	12.0	.67A	10	1,000	32	16
	12723	12724	500	774	T-2 1/4	G-4 Two Pin	12.0	.67A	13	50	32	4
		47618	500	777	T-2 1/4	G-4 Two Pin	4.0	1.20A	5.5	275	31	28
	49718			778	T-2 3/4	G-4 Two Pin	6.0	3.33A	32	100	32	15
	18344			780	T-2 3/4	G-4 Two Pin	12.0	10W	12	2,000	32	17
	44840	44841	500	782	T-2 3/4	G-4 Two Pin	12.0	1.66A	25	2,000	32	19
	44500	44501	500	783	T-2 1/4	G-4 Two Pin	12.0	1.00A	22	50	32	5
	43760	43761	500	784	T-2 1/4	G-4 Two Pin	6.0	1.00A	9	50	31	29
	43762	43763	500	785	T-2 1/4	G-4 Two Pin	6.0	1.33A	13	50	31	30
	43764	43765	500	786	T-2 1/4	G-4 Two Pin	6.0	2.00A	19	50	32	2
	43115	43116	500	787	T-2 1/4	G-4 Two Pin	6.0	1.67A	16	100	31	31
	43117	43118	500	788	T-2 1/4	G-4 Two Pin	6.0	3.33A	32	100	32	3
	43119			789	T-2 3/4	G-4 Two Pin	12.0	1.17A	22	200	32	18
	43121	43122	500	790	T-2 3/4	G-4 Two Pin	14.0	1.79A	42	200	32	23
	43123	43124	500	791	T-2 3/4	G-4 Two Pin	14.0	2.50A	61	200	32	24
	20469			795	T-4	S.C. Bayonet	12.8	50W	108	200	38	3
	40848	14132	540	862	T-3 1/4	Right Angle Prefocus	12.8	2.93A	60	1,900	35	6
12320		20904	540	880 (H27W/1)	T-3 1/4	Axial Prefocus / PG13	12.8	2.10A	43	300	34	23
							13.5	29W	38	150		
		27582	540	880L*	T-3 1/4	Axial Prefocus	12.8	2.10A	43	300	34	24
		14694	540	880X	T-3 1/4	Axial Prefocus	12.8	2.10A	43	1,000	34	25
12334		20905	540	881 (H27W/2)	T-3 1/4	Right Angle Prefocus / PGJ13	12.8	2.10A	43	300	35	1
							13.5	29W	38	150		
		27583	540	881L*	T-3 1/4	Right Angle Prefocus	12.8	2.10A	43	1,000	35	2
		11646	540	881X	T-3 1/4	Right Angle Prefocus	12.8	2.10A	43	300	35	3
	13158	13161	1000	882	T-2 1/4	Printed Circuit Socket	12.8	.35A	3.8	2,000	32	6
	18167	16772	500	882X	T-2 1/4	G-4 Two Pin	12.8	.35A	3.8	2,000	32	7
12335		20907	540	885	T-3 1/4	Axial Prefocus	12.8	3.90A	100	200	35	14
14689		20909	540	886	T-3 1/4	Right Angle Prefocus	12.8	3.90A	100	200	35	15

*New lamp added since last publication. Turquoise—Halogen Lamps

INDEX – MINIATURE LAMPS

Order Code			Bulk Std. Pkg. Qty.	Lamp No.	Bulb	Base	Design		Mean Spherical Candlepower (Approx.)	Rated Avg. Lab Life (Hours)	Page No.	Line No.
Blister Pack	Unit Pack	Bulk Pack					Volts	Watts or Amps				
		25639	540	887	T-3¼	Axial Prefocus	12.8	3.90A	95	400	35	16
		25703	540	888	T-3¼	Right Angle Prefocus	12.8	3.90A	95	400	35	17
12336		20910	540	889	T-3¼	Right Angle	12.8	2.10A	43	300	35	4
12337		20911	540	890	T-3¼	Axial	12.8	2.10A	43	300	35	5
12308	15246	15248	500	891	T-2¼	G-4 Two Pin	12.8	.63A	11	500	32	9
	16481			892	T-3¼	Axial	12.8	1.25A	28	300	34	22
12338		20913	540	893	T-3¼	Axial Prefocus	12.8	2.93A	75	200	35	7
		12727	540	893X	T-3¼	Axial Prefocus	12.8	2.93A	75	200	35	8
22112	20238	18455	540	894	T-3¼	Right Angle Prefocus	12.8	2.93A	75	200	35	9
		26345	540	894X*	T-3¼	Right Angle Prefocus	12.8	2.93A	75	200	35	10
22113		20914	540	896	T-3¼	Right Angle Prefocus	12.8	2.93A	75	200	35	11
		12271	540	898	T-3¼	Right Angle Prefocus	12.8	2.93A	60	1,900	35	12
22111		12272	540	899	T-3¼	Axial Prefocus	12.8	2.93A	60	1,900	35	13
14273		14007	1000	901	T-5	Wedge	12.8	.31A	2.9	500	39	16
40675				901A*	T-5	Wedge	12.8	.31A	-	500	39	17
23024	40462	40463	1000	904	T-5	Wedge	13.5	.69A	4	5,000	40	3
12366	40289	40290	1000	906	T-5	Wedge	13.0	.69A	6	1,000	39	25
		48505	1000	906A*	T-5	Wedge	13.0	.69A	-	1,000	39	26
	44754	44755	1000	908	T-5	Wedge	6.0	1.50A	12	50	39	14
	44756	44757	1000	909	T-5	Wedge	6.0	.62A	3	50	39	11
12365	40504	40505	1000	912	T-5	Wedge	12.8	1.00A	12	1,000	39	21
	44769			914	T-5	Wedge	4.0	.90A	3.5	50	39	9
	44771	44772	1000	915	T-5	Wedge	12.0	.75A	11	50	39	15
23025	16289	16288	1000	916	T-5	Wedge	13.5	.54A	2	10,000	40	2
23026	21860			916NA	T-5	Wedge	13.0	.54A	1.5	10,000	39	24
40179	17837	14008	2000	918	T-5	Wedge	12.8	.56A	6.5	500	39	18
26199				920	T-5	Wedge	12.8	1.20A	10	1,200	39	22
12307	43374	11743	1000	921	T-5	Wedge	12.8	1.40A	21	500	39	23
23027	13274	13275	1000	922	T-5	Wedge	12.8	.98A	15	200	39	20
40180				923	T-5	Wedge	12.8	.91A	12.5	500	39	19
	13483			926	T-5	Wedge	4.0	1.80A	7.5	50	39	10
	13485	13486	1000	927	T-5	Wedge	6.0	1.20A	8	50	39	13
	16975	15285	1000	939	T-5	Wedge	6.0	.90A	5.4	50	39	12
12367	26709			1003	B-6	S.C. Bayonet	12.8	.94A	15	200	23	15
47800				1003KR*	B-6	S.C. Bayonet	12.8	.94A	15	400	23	16
12373	26726	26728	500	1004	B-6	D.C. Bayonet	12.8	.94A	15	200	23	17
	26775			1034	S-8	D.C. Index	12.8	1.80A	32	200	27	20
							14.0	.59A	3	5,000		
40134	32147			1062	RP-11	D.C. Bayonet	40.0	.92A	50	100	26	8
	26838			1073	S-8	S.C. Bayonet	12.8	1.80A	32	200	27	21
	26854			1076	S-8	D.C. Bayonet	12.8	1.80A	32	200	27	22
	37169			1096	S-8	D.C. Pf. (S)	6.0	4.50A	30	500	26	12
	26872			1129	S-8	S.C. Bayonet	6.4	2.63A	21	200	27	1
	26885			1133	RP-11	S.C. Bayonet	6.2	3.91A	32	200	26	5
12346	26903	26905	500	1141	S-8	S.C. Bayonet	12.8	1.44A	21	1,000	27	15
47802				1141KR*	S-8	S.C. Bayonet	12.8	1.44A	21	2,000	27	16
	26917	26919	500	1142	S-8	D.C. Bayonet	12.8	1.44A	21	1,000	27	17
	26945			1152	S-8	D.C. Bayonet	12.8	1.34A	21	500	27	13
12297				1154	S-8	D.C. Index	6.4	2.63A	21	200	27	2
							7.0	.75A	3	1,000		
	26955			1155	G-6	S.C. Bayonet	13.5	.59A	4	5,000	25	12
12344	26960	26962	500	1156	S-8	S.C. Bayonet	12.8	2.10A	32	1,200	27	23
23334		11666	500	1156KR	S-8	S.C. Bayonet	12.8	2.10A	32	2,400	27	24
21028	20248			1156NA	S-8	S.C. Bayonet	12.8	2.10A	24	1,200	27	25

*New lamp added since last publication. **Turquoise-Halogen Lamps**

INDEX – MINIATURE HALOGEN LAMPS

Order Code			Bulk Std. Pkg. Qty.	Lamp No.	Bulb	Base	Design		Mean Spherical Candlepower (Approx.)	Rated Avg. Lab Life (Hours)	Page No.	Line No.
Blister Pack	Unit Pack	Bulk Pack					Volts	Watts or Amps				
12294	26969	26971	500	1157	S-8	D.C. Index	12.8	2.10A	32	1,200	27	26
							14.0	.59A	3	5,000		
23337				1157KR	S-8	D.C. Index	12.8	2.10A	32	2,400	27	27
							14.0	.59A	3	10,000		
12310	26975	26976	500	1157NA	S-8	D.C. Index	12.8	2.10A	24	1,200	27	28
							14.0	.59A	2.2	5,000		
47798				1157NAKR*	S-8	D.C. Index	12.8	2.10A	24	2,400	27	29
							14.0	.59A	2.2	10,000		
	27004			1176	S-8	D.C. Bayonet	12.8	1.34A	21	300	27	14
							14.0	.59A	6	1,500		
	27021	27023	500	1195	RP-11	S.C. Bayonet	12.5	3.00A	50	300	26	6
	27026			1196	RP-11	D.C. Bayonet	12.5	3.00A	50	300	26	7
	27032			1203	S-8	S.C. Bayonet	28.0	.71A	21	400	30	9
	27044			1224	G-6	D.C. Bayonet	34.0	.16A	3.8	500	25	24
	39904			1229	S-8	D.C. Bayonet	40.0	.38A	15	400	30	20
	27092			1251	G-6	S.C. Bayonet	28.0	.23A	3	2,000	25	18
	27097			1252	G-6	D.C. Bayonet	28.0	.23A	3	2,000	25	19
41755	22523			1295NA	S-8	S.C. Bayonet	12.5	3.00A	37	200	27	10
	12824			1308	B-6	S.C. Bayonet	28.0	.56A	16	2,000	23	20
	27118			1309	B-6	S.C. Bayonet	28.0	.52A	15	300	23	19
	32098			1315	G-5	S.C. Bayonet	2.5	1.00A	1.75	20	24	17
	34265			1317	B-6	S.C. Bayonet	6.00	.51A	3.4	100	23	13
	27150			1383	R-12	S.C. Bayonet	13.0	20W	—	300	26	1
	27154			1385	R-12	S.C. Bayonet	28.0	20W	—	300	26	3
	27159			1388	R-12	D.C. Bayonet	24.0	20W	—	500	26	2
	27179			1408	T-3 ¹ / ₄	Miniature Bayonet	10.0	.13A	.85	250	34	21
	27193			1434	T-5	S.C. Bayonet	3.7	2.75A	11	100	39	8
12329	27207	27209	4000	1445	G-3 1/2	Miniature Bayonet	14.4	.135A	.7	2,000	24	2
							18.0	.15A	1.5	250		
	27252			1449	G-3 1/2	Miniature Screw	14.0	.20A	2	250	23	26
	27263			1450	G-3 1/2	Miniature Bayonet	24.0	.035A	.23	3,000	24	3
	28310			1460	S-8	D.C. Pf. (A)	6.5	2.75A	23	100	27	3
	37342	37343	500	1460X	S-8	D.C. Pf. (A)	6.5	2.75A	23	100	27	4
	27305			1468	S-8	D.C. Pf. (S)	6.0	4.50A	30	500	26	13
	42677			1468X	S-8	D.C. Pf. (S)	6.0	4.50A	30	500	26	14
	27356			1487	T-3 ¹ / ₄	Miniature Screw	14.0	.20A	1.4	3,000	36	1
	27382			1493	S-8	D.C. Bayonet	6.5	2.75A	23	100	27	5
	27392			1495	T-4 ¹ / ₂	Miniature Bayonet	28.0	.30A	6	500	38	15
	44842			1495X	T-4 ¹ / ₂	Miniature Bayonet	28.0	.30A	6	500	38	16
	27431			1561	S-11	S.C. Pf. (B)	6.3	4.00A	24	1,500	30	21
	40943			1591	S-8	S.C. Bayonet	28.0	.61A	15	1,000	29	20
	40945			1591AF	S-8	S.C. Bayonet	28.0	.61A	—	1,000	29	21
	27439			1594	S-8	D.C. Bayonet	6.0	5.00A	36	250	26	15
	27461			1612	S-8	D.C. Bayonet	5.4	1.90A	10	1,000	26	9
	27472			1619	S-8	S.C. Bayonet	6.7	1.90A	15	500	27	8
	27488	27489	500	1630	S-8	D.C. Pf. (A)	6.5	2.75A	23	100	27	6
	27491			1631X	S-8	D.C. Pf. (A)	6.5	2.75A	23	100	27	7
	27496			1634	S-8	D.C. Pf. (A)	20.0	1.00A	24	200	29	15
	27504			1638	S-8	D.C. Bayonet	28.0	1.02A	32	500	30	18
	27529	27530	500	1662	S-8	D.C. Index	28.0	.93A	32	400	30	14
							28.0	.34A	6	1,000		
	27532			1665	S-8	S.C. Bayonet	28.0	.80A	21	1,000	30	11
	27533			1665AF	S-8	S.C. Bayonet	28.0	.80A	—	1,000	30	12
	27548			1680	S-8	S.C. Bayonet	6.0	4.10A	32	300	26	10
	33995			1680X	S-8	S.C. Bayonet	6.0	4.10A	32	300	26	11

*New lamp added since last publication. Turquoise—Halogen Lamps

INDEX – MINIATURE LAMPS

Order Code			Bulk Std. Pkg. Qty.	Lamp No.	Bulb	Base	Design		Mean Spherical Candlepower (Approx.)	Rated Avg. Lab Life (Hours)	Page No.	Line No.
Blister Pack	Unit Pack	Bulk Pack					Volts	Watts or Amps				
	27557			1683	S-8	S.C. Bayonet	28.0	1.02A	32	500	30	19
	27566			1691	S-8	S.C. Bayonet	28.0	.61A	15	1,000	29	22
	27568			1691AF	S-8	S.C. Bayonet	28.0	.61A	—	1,000	29	23
	27571			1692	S-8	D.C. Bayonet	28.0	.61A	15	1,000	30	1
	27630			1777	S-8	S.C. Bayonet	12.8	1.52A	26	400	27	18
	27667	27679	4000	1813	T-3¼	Miniature Bayonet	14.4	.10A	.86	1,000	36	23
	27677			1815	T-3¼	Miniature Bayonet	14.0	.20A	1.4	3,000	36	2
12359	27688			1816	T-3¼	Miniature Bayonet	13.0	.33A	3	1,000	35	21
	27707			1818	T-3¼	Miniature Bayonet	24.0	.17A	3.3	250	36	25
	27711	27712	1000	1819	T-3¼	Miniature Bayonet	28.0	.04A	.34	2,500	36	27
	27727			1820	T-3¼	Miniature Bayonet	28.0	.10A	1.6	1,000	37	3
	27749			1822	T-3¼	Miniature Bayonet	36.0	.10A	2.1	1,000	37	8
	27772			1828	T-3¼	Miniature Bayonet	37.5	.05A	.65	3,000	37	9
	27776			1829	T-3¼	Miniature Bayonet	28.0	.07A	1	1,000	36	29
	27804			1835	T-3¼	Miniature Bayonet	55.0	.05A	1.1	5,000	37	10
	27816			1843	T-3¼	Miniature Bayonet	28.0	.022A	.2	3,000	36	26
	27819			1847	T-3¼	Miniature Bayonet	6.3	.15A	.38	5,000	34	15
	27833			1850	T-3¼	Miniature Bayonet	5.0	.09A	.25	1,500	34	9
	27862	27863	1000	1864	T-3¼	Miniature Bayonet	28.0	.17A	3	1,500	37	6
	27868			1866	T-3¼	Miniature Bayonet	6.3	.25A	.65	5,000	34	19
	40383			1873	T-3¼	Miniature Bayonet	28.0	.20A	3	7,000	37	7
	27889			1876	T-5	S.C. Bayonet	3.5	2.50A	6.5	2,000	39	7
	27907			1889	T-3¼	Miniature Bayonet	14.0	.27A	2	2,000	36	13
12331	27917			1891	T-3¼	Miniature Bayonet	14.0	.24A	2	500	36	5
	27927			1892	T-3¼	Miniature Bayonet	14.4	.12A	.75	1,000	36	24
12332	27935	27937	4000	1893	T-3¼	Miniature Bayonet	14.0	.33A	2	7,500	36	18
12330	27945	27948	4000	1895	G-4½	Miniature Bayonet	14.0	.27A	2	2,000	24	14
	34021			1939X	T-7	S.C. Bayonet	28.0	1.79A	70	300	40	12
	28008			1940	T-7	S.C. Bayonet	14.0	3.57A	75	300	40	10
	37034			1944	T-7	S.C. Bayonet	14.0	3.57A	75	300	40	11
	18617			1946	T-3	Two Pin with Leads	28.0	250W	660	50	34	4
	28011			1958	T-4	Tab	28.0	150W	250	300	38	11
	39641			1962B	T-3	Wire Terminal	8.5	62W	110	50	33	4
		12859	100	1962BG	T-3	Wire Terminals	8.5	62W	110	50	33	5
		37947	100	1962DX	T-3	Wire Terminals	8.5	62W	80	150	33	6
	44152			1962DZ	T-3	Wire Terminals	8.5	62W	80	150	33	7
	13667			1962TY	T-3	Wire Terminals	8.5	62W	110	50	33	8
	28034			1968	T-3	Double Slide	28.0	25W	15	500	33	20
	28036			1970	T-3	Special Sleeve	28.0	100W	150	1,000	34	1
	41938			1970X	T-3	Special Sleeve	28.0	100W	140	1,000	34	2
	32780			1974	T-3	Wire Terminals	6.0	20W	10	10,000	33	2
	38545			1978X	T-3	Special	10.0	100W	130	2,000	33	9
	38627			1982	T-3	S.C. Bayonet	28.0	75W	110	1,000	33	22
	21061			1982SP	T-3	S.C. Bayonet	28.0	75W	107	2,000	33	23
	39718			1983	T-4	Two Pin	10.0	100W	130	2,000	38	1
	44717			1986	T-4	Wire Terminal	28.0	250W	600	100	38	13
						S.C. Prefocus Collar						
	47695			1987	T-4	D.C. Bayonet	28.0	150W	240	700	38	12
	38535			1988	T-3	Special Wire Leads	10.0	100W	130	2,000	33	10
12326	19280			2040	T-2¼	Wedge	12.8	.625A	10.5	500	32	8
12296	44760	18620	500	2057	S-8	D.C. Index	12.8	2.10A	32	1,200	28	1
							14	.48A	2	5,000		
23339		10018	500	2057KR	S-8	D.C. Index	12.8	2.10A	32	2,400	28	2
							14.0	.48A	2	10,000		

*New lamp added since last publication. **Turquoise—Halogen Lamps**

INDEX – MINIATURE LAMPS												
Order Code			Bulk Std. Pkg. Qty.	Lamp No.	Bulb	Base	Design		Mean Spherical Candlepower (Approx.)	Rated Avg. Lab Life (Hours)	Page No.	Line No.
Blister Pack	Unit Pack	Bulk Pack					Volts	Watts or Amps				
12312	44763	44764	500	2057NA	S-8	D.C. Index	12.B	2.10A	24	1,200	28	3
							14.0	.48A	1.5	5,000		
47799				2057NAKR*	S-8	D.C. Index	12.B	2.10A	24	2,400	28	4
							14.0	.48A	1.5	10,000		
		12899	600	2058U	S-8	Wire Terminals	12.B	2.10A	32	1,200	28	5
							14.0	.48A	2	5,000		
	26697			2059*	T-2½	Miniature Bayonet	12.0	.833A	9.1	4,000	32	10
	2669B			2059X*	T-2½	Miniature Bayonet	12.0	.833A	8	4,000	32	11
	21494			2074	T-3	Wire Terminals	7.0	25W	24	2,700	33	3
		280B5	600	2144	S-8	Wire Terminals	12.B	2.10A	32	1,200	28	6
		32701	500	2155	S-8	Wire Terminals	28.0	.93A	32	400	30	15
							28.0	.34A	6	1,000		
	34763			2232	S-8	S.C. Bayonet	28.0	.643A	1B	2,000	30	2
	26702			2232LL*	S-8	S.C. Bayonet	28.0	.643A	1B	4,000	30	3
	43134			2232SB	S-8	S.C. Bayonet	28.0	.643A	—	2,000	30	4
	36906			2233	S-8	S.C. Bayonet	28.0	.766A	21	2,000	30	10
		44964	1000	2286D	T-3¼	Wire Term Down	14.0	.35A	2.7	1,500	36	21
	28100			2331	RP-11	D.C. Pf. (S)	5.9	4.66A	32	400	26	4
							6.2	4.49A	32	400		
1229B	16291	16290	500	2357	S-8	D.C. Index	12.B	2.20A	40	400	28	16
							14.0	.59A	3	5,000		
12299	1569B	15699	500	2357NA	S-8	D.C. Index	12.B	2.20A	30	400	28	17
							14.0	.59A	2.2	5,000		
	18047			2396	S-8	S.C. Bayonet	12.B	2.23A	40	400	28	18
27560				2397*	S-8	D.C. Index	12.B	2.23A	40	400	28	19
							14.0	.48A	2	5,000		
		19792	100	2556	T-3	Two Pin	28.0	200W	525	50	34	3
		19566	100	2986	T-4	Two Pin with Insulation Leads	28.0	250W	600	100	38	14
	43805			2604X	TL-2¾	G-4 Two Pin	5.0	2.00A	—	5,000	33	1
	3650B			3011	S-11	S.C. Bayonet	28.0	1.29A	44	1,000	30	24
12305	183B9			3057	S-8	Plastic Wedge	12.B	2.10A	32	1,200	28	7
							14.0	.48A	2	5,000		
2637B				3057KR	S-8	Plastic Wedge	12.B	2.10A	32	2,000	28	8
							14.0	.48A	2	10,000		
12313	18391			3057NA	S-8	Plastic Wedge	12.B	2.10A	24	1,200	28	9
							14.0	.48A	1.5	5,000		
	146B9			3078*	T-3	Special	10.0	100W	95	4,500	33	11
2302B				3155	S-8	Plastic Wedge	12.B	1.60A	21	1,500	27	19
12351	21863			3156	S-8	Plastic Wedge	12.B	2.10A	32	1,200	28	10
27565				3156KR*	S-8	Plastic Wedge	12.B	2.10A	32	2,000	28	11
12306	17172			3157	S-8	Plastic Wedge	12.B	2.10A	32	1,200	28	12
							14.0	.59A	3	5,000		
26377				3157KR	S-8	Plastic Wedge	12.B	2.10A	32	2,000	28	13
							14.0	.59A	3	10,000		
12314	17173			3157NA	S-8	Plastic Wedge	12.B	2.10A	24	1,200	28	14
							14.0	.59A	2.2	5,000		
263B0				3157NAKR	S-8	Plastic Wedge	12.B	2.10A	24	2,000	28	15
							14.0	.59A	2.2	10,000		
143B7	22525			3357/3457	S-8	Plastic Wedge	12.B	2.23A	40	400	29	1
							14.0	.59A	3	5,000		
26379				3357KR/3457KR	S-8	Plastic Wedge	12.B	2.23A	40	800	29	2
							14.0	.59A	3	10,000		
143BB	22526			3357NA/3457NA	S-8	Plastic Wedge	12.B	2.23A	30	400	29	3
							14.0	.59A	2.2	5,000		

*New lamp added since last publication. **Turquoise**—Halogen Lamps

INDEX – MINIATURE LAMPS

Order Code			Bulk Std. Pkg. Qty.	Lamp No.	Bulb	Base	Design		Mean Spherical Candlepower (Approx.)	Rated Avg. Lab Life (Hours)	Page No.	Line No.
Blister Pack	Unit Pack	Bulk Pack					Volts	Watts or Amps				
25834				3496	T-7	D.C. Index	12.8	2.10A	43	600	40	6
							14.0	.59A	3	5,000		
25835				3497	T-7	S.C. Bayonet	12.8	2.10A	45	600	40	7
25837				3652	T-3¼	Wedge	13.5	.37A	6	700	35	24
15657				4157KR*	S-8	Plastic Wedge	12.8	2.23A	32	3,600	29	5
							14.0	.59A	3	10,000		
47458				4157NAKR*	S-8	Plastic Wedge	12.8	2.23A	24	3,600	29	6
							14.0	.59A	2.2	10,000		
	28154			5004CW	T-5	Miniature Pinless	A.C.	4W	—	7,500	41	1
	28155			5004WW	T-5	Miniature Pinless	A.C.	4W	—	7,500	41	2
	28160			5008CW	T-5	Miniature Pinless	A.C.	8W	—	7,500	41	7
	28163			5008WW	T-5	Miniature Pinless	A.C.	8W	—	7,500	41	8
	28168			5013CW	T-5	Miniature Pinless	A.C.	13W	—	7,500	41	11
	28169			5013WW	T-5	Miniature Pinless	A.C.	13W	—	7,500	41	12
	27367			5104CW*	T-5	Miniature Bi-Pin	A.C.	4W	—	7,500	41	3
	28173			5104WW	T-5	Miniature Bi-Pin	A.C.	4W	—	7,500	41	4
	12774			5106CW	T-5	Miniature Bi-Pin	A.C.	6W	—	7,500	41	5
	33612			5106WW	T-5	Miniature Bi-Pin	A.C.	6W	—	7,500	41	6
	27466			5108CW*	T-5	Miniature Bi-Pin	A.C.	8W	—	7,500	41	9
	28175			5108WW	T-5	Miniature Bi-Pin	A.C.	8W	—	7,500	41	10
	12775			5113CW	T-5	Miniature Bi-Pin	A.C.	13W	—	7,500	41	13
	28178			5113WW	T-5	Miniature Bi-Pin	A.C.	13W	—	7,500	41	14
	28926			7387	T-1¾	Bi-Pin M-23	28.0	.04A	.3	7,000	31	18
26200				7440	T-7	Wedge / 103 x 16DQ	13.5	1.85	37	300	40	8
26201		10014	1000	7443	T-7	Wedge / 103 x 16DQ	13.5	1.85	35	500	40	9
							13.5	0.4	3	1,000		
22432	22389	14542	200	9003/HB2	T-4¾	P43T-38	12.8	67W	119	150	39	5
							12.8	60W	72	800		
45470				9003SB*	T-4¾	P43T-38	12.8	67W	119	80	39	6
							12.8	60W	72	150		
18508	13382	18699	250	9004/HB1	T-4¾	Axial Plastic Prefocus	12.8	65W	95	150	38	19
							12.8	45W	55	320		
27561				9004HO*	T-4¾	Axial Plastic Prefocus	12.8	65W	95	150	38	20
							12.8	42W	56	640		
45471				9004SB*	T-4¾	Axial Plastic Prefocus	12.8	65W	95	40	38	21
							12.8	45W	56	200		
13993	11249	20559	250	9004XL	T-4¾	Axial Plastic Prefocus	12.8	65W	95	150	38	22
							12.8	47W	55	850		
18509	13384	14710	200	9005/HB3	T-4	Right Angle Plastic, Prefocus	12.8	65W	135	800	38	8
45472				9005SB*	T-4	Right Angle Plastic, Prefocus	12.8	65W	135	150	38	9
45866				9005XSLL*	T-4	Axial Plastic Prefocus	12.8	65W	135	700	38	10
18510	13397	14711	200	9006/HB4	T-4	Right Angle Plastic, Prefocus	12.8	55W	80	850	38	4
47640				9006HO*	T-4	Right Angle Plastic, Prefocus	12.8	55W	80	1,000	38	5
45473				9006SB*	T-4	Right Angle Plastic, Prefocus	12.8	55W	80	320	38	6
45868				9006XSLL*	T-4	Axial Plastic Prefocus	12.8	55W	80	2,000	38	7
22388	20551			9007/HB5	T-4¾	Axial Plastic Prefocus	12.8	65W	107	150	39	1
							12.8	55W	79	1,100		
47642				9007HO*	T-4¾	Axial Plastic Prefocus	12.8	65W	107	150	39	2
							12.8	53W	80	320		
		10209	250	9007LL	T-4¾	Axial Plastic Prefocus	12.8	65W	107	150	39	3
							12.8	55W	79	1,450		
45474				9007SB*	T-4¾	Axial Plastic Prefocus	12.8	65W	107	110	39	4
							12.8	58W	80	250		
		14776	360	9011	T-3¼	PX20D	12.8	65W	183	150	35	19
		47327	900	9011X HIR*	T-3¼	PX20D	12.8	65W	183	150	35	20

*New lamp added since last publication. Turquoise—Halogen Lamps

INDEX – MINIATURE HALOGEN LAMPS

Order Code			Bulk Std. Pkg. Qty.	Lamp No.	Bulb	Base	Design		Mean Spherical Candlepower (Approx.)	Rated Avg. Lab Life (Hours)	Page No.	Line No.
Blister Pack	Unit Pack	Bulk Pack					Volts	Watts or Amps				
		41495	360	9012 (HIR2)*	T-3 1/4	PX 22D	12.8	55W	135	900	35	18
40843		37735	200	9145 (H10)*	T-4	PY20D	12.8	45W	65	1,500	38	2
40336	2732B	32376	300	50310/1 (H1-55)	T-3 1/2	P14.5S	13.2	62W	123	225	37	17
	27569			50320/1 (H1-70/28V)	T-3 1/2	P14.5S	28.0	80W	151	600	37	27
12339	27331	22132	400	50340 (H3-55)	T-3 1/2	PK22S	13.2	62W	115	225	37	18
		23445	400	50340HD (H3-55)	T-3 1/2	PK22S	13.2	62W	111	600	37	19
		35044	400	50340LL (H3-55)	T-3 1/2	PK22S	13.2	64W	106	2,000	37	21
	27332	23438	400	50350 (H3-70/28V)	T-3 1/2	PK22S	28.0	75W	135	225	37	26
		23442	400	50390 (H3-35)	T-3 1/2	PK22S	13.2	40W	60	200	37	12
	27330	22130	400	50410 (H2-55)	T-3 1/2	X511	13.2	62W	143	225	37	20
18132	27334	22133	200	50440 (H4-60/55)	T-5	P43T-38	13.2	71W	138	225	40	1
							13.2	66W	80	900		
	27342	30833	200	50450 (H4-75/70/28V)	T-5	P43T-38	28.0	80W	151	150	40	5
							28.0	73W	95	300		
12341				52130 (H3-100)	T-3 1/2	PK22S	13.2	92W	187	100	37	23
	27329			52140 (H1-100)*	T-3 1/2	P14.5S	13.2	100W	219	100	37	24
		23428	400	52590HD (H3-65/28V)	T-3 1/2	PK22S	28.0	66W	102	1,000	37	25
45591				56110*	T-3	Miniature Bayonet	13.2	1.83A	40	100	33	14
26374		35755	200	58520 (H7-55)	T-3 1/2	PX26D	13.2	56.5W	115	500	37	16
47461				58540*	T-3	Miniature Bayonet	13.5	.37A	63	240	33	15
	26696			A-103*	T-3	Special	28.0	50W	60	1,000	33	21
23312		30872		C5W	T-3 1/2	SV8.5/8	13.5	.37A	3.6	450	42	4
		16124	144	D2R*	T-3	P32d-2	85	35W	114	1,000	41	15
		15999	144	D2S*	T-3	P32d-2	85	35W	254	1,000	41	16
25323				DE3021	T-2 1/4	SV7MM	14.0	.24A	2	1,000	42	5
12353				DE3022	T-2 1/4	SV7MM	13.0	.38A	3	1,000	42	6
12354	12084			DE3175	T-3 1/4	SV8.5MM	13.0	.77A	9.55	400	42	7
	12085			DE3425	T-4	SV8.5MM	13.0	.77A	9.55	400	42	8
23324				DE7576	T-3 1/2	SV8.5/8	13.5	.74A	9.8	200	42	9
		15765	300	H8*	T-3 1/2	PGJ19-1	13.2	40W	64	400	37	13
		15827	300	H9*	T-3 1/2	PGJ19-5	13.2	65W	167	125	37	22
		15828	300	H11*	T-3 1/2	PGJ19-2	13.2	55W	107	550	37	14
		15963	300	H11LL*	T-3 1/2	PGJ19-2	13.2	55W	107	1,400	37	15
22961				KPR102	B-3 1/2	S.C. Miniature Flanged	2.4	.70A	1.3	15	23	4
23151				KPR104	B-3 1/2	S.C. Miniature Flanged	2.2	.47A	.47	15	23	1
23153				KPR113	B-3 1/2	S.C. Miniature Flanged	4.8	.75A	4.1	20	23	9
23154				KPR118	B-3 1/2	S.C. Miniature Flanged	7.2	.55A	5.2	15	23	11
	12571			ML20/ OF-28	T-8	Disk	28.0	20W	—	500	40	13
23306		11601	1000	P21W (P25-1)	S-8	S.C. Bayonet	13.5	1.85A	36.6	250	29	12
		38655	1000	P21WLL*	S-8	S.C. Bayonet	13.5	1.85A	36.6	300	29	13
27561		30857	1000	P21/4W*	S-8	D.C. Index	13.5	1.85A	35	100	29	9
							13.5	.37A	1.19	100		
23303		11604	1000	P21/5W (P25-2)	S-8	D.C. Index	13.5	1.85A	35	250	29	10
							13.5	.44A	2.78	1,000		
		92475	1000	P21/5W LL*	S-8	D.C. Index	13.5	1.85A	35	600	29	11
							13.5	.44A	2.78	3,000		
	40778			P21W 24V*	S-8	S.C. Bayonet	28.0	1.00A	36.6	150	30	17
		30856	1000	P21/5W*	S-8	D.C. Index	28.0	1.00A	35	150	30	16
							28.0	.36A	3.18	1,500		
		23036	1000	PC161	T-3 1/4	Printed Circuit Socket	14.0	.19A	1	4,000	35	29
	27222	23037	1000	PC168	T-3 1/4	Printed Circuit Socket	14.0	.35A	3	1,500	36	22
	72221	23021	1000	PC194	T-3 1/4	Printed Circuit Socket	14.0	.27A	2	2,500	36	14
12675	25181			PR2	B-3 1/2	S.C. Miniature Flanged	2.38	.50A	.8	15	23	3

*New lamp added since last publication. Turquoise—Halogen Lamps

INDEX – MINIATURE LAMPS

Order Code			Bulk Std. Pkg. Qty.	Lamp No.	Bulb	Base	Design		Mean Spherical Candlepower (Approx.)	Rated Avg. Lab Life (Hours)	Page No.	Line No.
Blister Pack	Unit Pack	Bulk Pack					Volts	Watts or Amps				
12676	25193			PR3	B-3½	S.C. Miniature Flanged	3.57	.50A	1.5	15	23	6
12677				PR4	B-3½	S.C. Miniature Flanged	2.33	.27A	.4	10	23	2
	25222			PR6	B-3½	S.C. Miniature Flanged	2.47	.30A	.45	30	23	5
	25235			PR7	B-3½	S.C. Miniature Flanged	3.70	.30A	.9	30	23	7
12680	25252			PR12	B-3½	S.C. Miniature Flanged	5.95	.50A	3.1	15	23	10
12681	25262			PR13	B-3½	S.C. Miniature Flanged	4.75	.50A	2.2	15	23	8
	25289			PR18	B-3½	S.C. Miniature Flanged	7.20	.55A	5.5	3	23	12
41370		32648	500	PY21W*	S-8	S.C. Bayonet	13.5	1.85A	22.3	250	29	14
23314		30859	2000	R5W LL	G-6	S.C. Bayonet	13.5	5W	4.0	500	25	15
23322		35417	2000	R10W LL	G-6	S.C. Bayonet	13.5	10W	10.0	400	25	14
23318				T4W	T-2¾	Miniature Bayonet	13.5	.30A	2.8	450	32	20
27562		35030	2000	W3W	T-3¼	Wedge	13.5	3W	1.75	1,000	35	22
27563		37640	2000	W5W	T-3¼	Wedge	13.5	5W	4	300	35	25
		26353	1000	W16W	T-5	Wedge	13.5	1.44A	24.6	250	40	4

INDEX – NEON GLOW LAMPS

Order Code			Bulk Std. Pkg. Qty.	Lamp No.	Bulb	Base	Design		Rated Avg. Lab Life (Hours)	Page No.	Line No.
Blister Pack	Unit Pack	Bulk Pack					Volts	Watts or Amps			
	12064			B1A (NE-51)	T-3¼	Miniature Bayonet	105-125	.0003A	15,000	42	1
	12065			B2A (NE-51H)	T-3¼	Miniature Bayonet	105-125	.0012A	25,000	42	2
	31675			B7A (NE-45)	T-4½	Candelabra Screw	105-125	.002A	7,500	42	3

INDEX – SEALED BEAM LAMPS

Order Code			Bulk Std. Pkg. Qty.	Lamp No.	Bulb	Base	Design		Mean Spherical Candlepower (Approx.)	Rated Avg. Lab Life (Hours)	Page No.	Line No.
Blister Pack	Unit Pack	Bulk Pack					Volts	Watts or Amps				
	18511			4000	PAR46	3 Contact Lugs	12.8	37.5W	SAE	200	47	34
							12.8	60W		320		
	18516	24231	672	4001	PAR46	2 Contact Lugs	12.8	37.5W	SAE	300	47	35
	24327			4013	PAR46	Screw Terminals	6.4	25W	800	300	47	24
	24339			4014	PAR36	Screw Terminals	6.4	18W	1,500	200	45	24
	24369			4019	PAR46	Screw Terminals	6.2	30W	1,200	300	47	23
	38418			4040	PAR46	3 Contact Lugs	12.8	37.5W	SAE	300	47	36
							12.8	60W		500		
	39585	39586	60	4042	PAR36	Screw Terminals	6.4	12W	1,100	150	45	23
	40588	40589	60	4044	PAR36	Screw Terminals	12.0	12W	1,100	150	45	29
	10540	10541	60	4044-1	PAR36	Slip-on Terminals	12.0	12W	1,100	150	45	30
	25051			4313	PAR36	Screw Terminals	13.0	250W	140,000	25	47	1
	39366	39367	60	4340	PAR36	Slip-on Terminals	48.0	80W	2,500	400	47	22
	39362	39363	60	4350	PAR36	Slip-on Terminals	36.0	60W	2,100	400	47	21
	12961			4402A	PAR36	Screw Terminals	28.0	50W	1,000	400	47	4
	24425	24423	60	4405	PAR36	Screw Terminals	12.8	30W	50,000	100	46	5
	24430	24428	60	4406	PAR36	Screw Terminals	12.8	35W	600	300	46	11
	24439			4410	PAR36	Screw Terminals	12.8	35W	600	300	46	12
	24448	24443	60	4411	PAR36	Screw Terminals	12.8	35W	3,000	300	46	13
	37889			4411-1	PAR36	Slip-on Terminals	12.8	35W	3,000	300	46	14
		48032	60	4411-3*	PAR36	Combination	12.8	35W	3,000	300	46	15
	24454	24453	24	4412	PAR46	Screw Terminals	12.8	35W	11,000	300	47	28
	24460	24459	24	4412A	PAR46	Screw Terminals	12.8	35W	8,800	300	47	29
	22981	24464	24	4413	PAR46	Screw Terminals	12.8	35W	1,100	300	47	30
	24478	24477	60	4414	PAR36	Screw Terminals	12.8	18W	1,500	300	46	1
	24487			4414R	PAR36	Screw Terminals	12.8	18W	275	300	46	2
	22982			4415	PAR36	Screw Terminals	12.8	35W	9,000	300	46	16
	24499	24497	60	4415A	PAR36	Screw Terminals	12.8	35W	7,000	300	46	17
	22983	24503	60	4416	PAR36	Screw Terminals	12.8	30W	35,000	300	46	6
		34901	60	4416-1	PAR36	Slip-on Terminals	12.8	30W	35,000	300	46	7

*New lamp added since last publication. [Turquoise-Halogen Lamps](#)

INDEX – SEALED BEAM LAMPS

Order Code			Bulk Std. Pkg. Qty.	Lamp No.	Bulb	Base	Design		Mean Spherical Candlepower (Approx.)	Rated Avg. Lab Life (Hours)	Page No.	Line No.
Blister Pack	Unit Pack	Bulk Pack					Volts	Watts or Amps				
	24506			4416A	PAR36	Screw Terminals	12.8	30W	26,000	300	46	8
	24513			4416R	PAR36	Screw Terminals	12.8	30W	4,000	300	46	9
	24531	24525	24	4419	PAR46	Screw Terminals	12.8	35W	1,600	300	47	31
	24539	24541	24	4421	PAR46	Slip-on Terminals	13.0	100W	23,000	300	48	11
	24542			4422	PAR36	Screw Terminals	12.8	35W	600	300	46	18
	24572			4434A	PAR46	Screw Terminals	12.8	40W	1,000	100	47	38
	24577	24576	24	4435	PAR46	Screw Terminals	12.8	30W	75,000	100	47	27
	24582			4436	PAR46	Screw Terminals	12.8	35W	60,000	300	47	32
	39932	39933	60	4440X	PAR36	3 Contact Lugs	12.8	40W	6,000	320	46	23
							12.8	40W	4,500	320		
	39748			4440X-1	PAR36	3 Slip-on Terminals	12.8	40W	6,000	320	46	24
							12.8	40W	4,500	320		
	37046	37047	60	4446	PAR36	Screw Terminals	12.8	25W	400	300	46	4
	40176			4460X	PAR36	3 Screw Terminals	12.8	40W	6,500	320	46	25
							12.8	40W	5,000	320		
	24592			4461	PAR36	Screw Terminals	12.8	60W	6,000	300	46	31
	24596			4466	PAR36	Screw Terminals	12.8	60W	1,000	300	46	32
	24613			4478	PAR46	2 Contact Lugs	13.0	60W	1,600	800	48	8
	24627			4502	PAR36	Screw Terminals	28.0	50W	10,000	400	47	5
	24640	24638	60	4505	PAR36	Screw Terminals	28.0	50W	45,000	400	47	6
	24650	24649	60	4509	PAR36	Screw Terminals	13.0	100W	110,000	25	46	34
	41503			4509X	PAR36	Screw Terminals	13.0	100W	110,000	25	46	35
	11524			4509Y	PAR36	Screw Terminals	13.0	100W	—	25	46	36
	24654	24653	60	4510	PAR36	Screw Terminals	6.4	25W	800	300	45	25
	24663	24661	60	4511	PAR36	Screw Terminals	6.2	30W	2,300	300	45	21
	24673	24671	60	4515	PAR36	Screw Terminals	6.4	30W	55,000	100	45	26
	24678			4516	PAR36	Screw Terminals	6.2	30W	45,000	300	45	22
	24690			4519	PAR36	Screw Terminals	13.0	100W	30,000	25	46	37
	24700			4522	PAR46	Screw Terminals	13.0	250W	290,000	25	48	15
	24721			4530	PAR46	Screw Terminals	26.0	5.3A	100,000	50	48	18
	24726			4531	PAR46	Screw Terminals	12.5	40W	30,000	400	47	26
	19628			4532	PAR46	Screw Terminals	28.0	250W	75,000	100	48	25
							28.0	150W	14,500	100		
	24735	24733	24	4535	PAR46	Screw Terminals	6.4	30W	95,000	100	47	25
	24742			4537	PAR46	Screw Terminals	13.0	100W	200,000	25	48	12
	40822	40823	24	4537-2	PAR46	Screw Terminals	13.0	100W	200,000	25	48	13
	39022			4537X	PAR46	Screw Terminals	13.0	100W	200,000	25	48	14
	24756			4541	PAR56	Screw Terminals	28.0	450W	470,000	25	49	10
	24764			4543	PAR56	Screw Terminals	12.5	100W	250,000	50	49	3
	24768			4545	PAR56	Screw Terminals	12.0	100W	225,000	100	49	2
	24780	24783	60	4546	PAR36	Screw Terminals	4.7	.5A	6,300	100	45	8
	24770	24775	60	4546-1	PAR36	Slip-on Terminals	4.7	.5A	6,300	100	45	9
	24788			4547	PAR36	Screw Terminals	4.75	1.25A	20,000	100	45	10
	24795			4551	PAR46	Screw Terminals	28.0	250W	75,000	25	48	26
	40576			4552	PAR64	Screw Terminals	28.0	250W	500,000	25	49	11
	24799			4553	PAR46	Screw Terminals	28.0	250W	300,000	25	48	27
	24802			4554	PAR46	Screw Terminals	28.0	450W	90,000	25	48	29
	40583			4555	PAR64	Screw Terminals	115.0	1,000W	600,000	25	49	19
	40581			4557	PAR64	3 Screw Terminals	28.0	1,000W	540,000	25	49	17
							28.0	400W	100,000	100		
	40578			4559	PAR64	Screw Terminals	28.0	600W	600,000	25	49	12
	24828			4570	PAR46	Screw Terminals	28.0	150W	32,000	300	48	22
	24830			4571	PAR46	Screw Terminals	28.0	150W	7,000	300	48	23
	24833			4572	PAR46	Screw Terminals	28.0	150W	4,500	300	48	24
	25005	25007	24	4578	PAR46	2 Contact Lugs	28.0	60W	1,600	800	48	19

*New lamp added since last publication. Turquoise—Halogen Lamps

INDEX – SEALED BEAM LAMPS

Order Code			Bulk Std. Pkg. Qty.	Lamp No.	Bulb	Base	Design		Mean Spherical Candlepower (Approx.)	Rated Avg. Lab Life (Hours)	Page No.	Line No.
Blister Pack	Unit Pack	Bulk Pack					Volts	Watts or Amps				
	25009	25011	24	4579	PAR46	3 Contact Lugs	28.0	80W	24,000	400	48	21
	24859			4580	PAR46	Screw Terminals	28.0	60W	11,000	400	48	30
	24862			4581	PAR46	Screw Terminals	28.0	450W	400,000	10	48	31
	24853			4582	PAR46	Screw Terminals	28.0	450W	400,000	10	48	32
	24867			4587	PAR36	Screw Terminals	28.0	450W	20,000	10	48	32
	24867			4587	PAR36	Screw Terminals	28.0	250W	40,000	25	47	19
	24873	24871	60	4589	PAR36	Screw Terminals	28.0	50W	5,000	400	47	7
		23509	60	4589-1	PAR36	Slip-on Terminals	28.0	50W	5,000	400	47	8
	24882			4591	PAR36	Screw Terminals	28.0	100W	90,000	25	47	12
	24887			4593	PAR36	Screw Terminals	28.0	50W	1,500	400	47	9
	24891			4594	PAR36	Screw Terminals	28.0	100W	70,000	300	47	13
	24892			4595	PAR36	Screw Terminals	28.0	100W	60,000	300	47	14
	24898			4596	PAR36	Screw Terminals	28.0	250W	150,000	25	47	20
	24964			4626	PAR36	Screw Terminals	28.0	150W	25,000	300	47	17
	24966			4627	PAR36	Screw Terminals	28.0	100W	3,000	300	47	15
	33284			4635	PAR46	Screw Terminals	16.5	450W	325,000	25	48	17
	19632	16407	672	4636-3	PAR46	Combination	14.0	80W	90,000	200	48	16
	18517	41861	576	4651	165mm	2 Contact Lugs	12.8	50W	SAE	200	44	21
	18518			4652	165mm	3 Contact Lugs	12.8	40W	SAE	200	44	17
							12.8	60W		320		
	39906	39907	60	4700	PAR36	3 Screw Terminals	13.0	100W	100,000	25	46	38
							13.0	100W	50,000	25		
	45427			4713	PAR36	Screw Terminals	28.0	150W	4,200	300	47	18
	44724			4752	PAR36	Screw Terminals	28.0	60W	2,000	800	47	11
	24973			4800	PAR56	3 Contact Lugs	28.0	50W	SAE	400	49	9
							28.0	40W		400		
	24980			4811	PAR36	3 Contact Lugs	28.0	110W	SAE	400	47	16
							28.0	55W		400		
	24981	24982	60	4825R	PAR36	3 Screw Terminals	28.0	50W	200	200	47	10
							28.0	18W	40	200		
	24995			4880	PAR46	2 Contact Lugs	28.0	60W	6,000	800	48	20
	45110	45111	576	4912-1	165mm	Slip-on Terminals	12.8	50W	14,000	300	44	22
		45113	16	4913-1	165mm	Slip-on Terminals	12.8	50W	1,350	400	44	23
	45116	16195	576	4921-1	165mm	Slip-on Terminals	13.0	100W	25,000	300	45	2
	11639			5001*	PAR46	2 Contact Lugs	12.8	50W	SAE	300	48	1
	16152			5557	PAR64	3 Screw Terminals	28.0	1,000W	540,000	50	49	18
							28.0	400W	100,000	100		
	25114			6006	PAR56	3 Contact Lugs	6.1	50W	SAE	300	49	1
							6.2	40W		500		
	18519			6014	PAR56	3 Contact Lugs	12.8	60W	SAE	320	49	5
							12.8	50W		150		
	38416	38607	432	6015	PAR56	3 Contact Lugs	12.8	50W	SAE	300	49	4
							12.8	50W		500		
	25153			6045	PAR56	Screw Terminals	26.0	170W	230,000	100	49	8
	18521			6052	200mm	3 Contact Lugs	12.8	65W	SAE	150	45	3
							12.8	55W		320		
	40190	40191	60	7400	PAR36	Slip-on Terminals	12.8	35W	33,000	300	46	19
		42385	60	7400-1	PAR36	Screw Terminals	12.8	35W	33,000	300	46	20
	39987	39988	60	7414Y	PAR36	Screw Terminals	12.8	18W	1,000	300	46	3
	41865	41866	60	7613	PAR36	Screw Terminals	6.0	8W	400	50	45	13
	45101	45102	60	7613-1	PAR36	Slip-on Terminals	6.0	8W	400	50	45	14
	11421	11422	60	7672-1	PAR36	Slip-on Terminals	6.0	7.2W	350	50	45	12
	22386			H4351	140mm	Right Angle, Plastic	12.8	55W	SAE	500	44	3
	10211			H4351LH*	140mm	Right Angle, Plastic	12.8	55W	—	500	44	4
	22387			H4352	140mm	Right Angle, Plastic	12.8	65W	SAE	150	44	5

*New lamp added since last publication. **Turquoise-Halogen Lamps**

INDEX – SEALED BEAM LAMPS												
Order Code			Bulk Std. Pkg. Qty.	Lamp No.	Bulb	Base	Design		Mean Spherical Candlepower (Approx.)	Rated Avg. Lab Life (Hours)	Page No.	Line No.
Blister Pack	Unit Pack	Bulk Pack					Volts	Watts or Amps				
		18350	48	H4360	140mm	2 Right Angle Lugs	12.8	37.5W	2,000	320	44	1
	15129			H4405	PAR36	Screw Terminals	12.8	30W	66,000	100	46	10
		17674	60	H4460X	PAR36	3 Screw Terminals	12.8	40W	11,000	320	46	26
	15133			H4515	PAR36	Screw Terminals	12.8	40W	8,500	320		
	18532	45027	576	H4651	165mm	2 Contact Lugs	6.4	30W	67,000	100	45	27
	46375			H4651SB*	165mm	2 Contact Lugs	12.8	50W	SAE	200	44	24
	18533	49810	576	H4656	165mm	3 Contact Lugs	12.8	50W	SAE	200	44	25
							12.8	35W	SAE	200	44	16
	14753			H4656HO	165mm	3 Contact Lugs	12.8	35W		320		
							12.8	40W	SAE	200	44	18
	45475			H4656SB*	165mm	3 Contact Lugs	12.8	55W		700		
							12.8	40W	SAE	75	44	19
							12.8	55W		200		
	18535	22879	576	H4666	165mm	3 Contact Lugs	12.8	65W	SAE	150	44	29
							12.8	55W		320		
	18536	48533	480	H4701	150mm	2 Lugs	12.8	65W	SAE	150	44	15
	18538	48534	480	H4703	150mm	2 Lugs	12.8	55W	SAE	320	44	14
	18522			H5001	PAR46	2 Contact Lugs	12.8	50W	SAE	200	48	2
	18523			H5006	PAR46	3 Contact Lugs	12.8	35W	SAE	200	47	33
							12.8	35W		320		
	19428	19559	432	H5024	PAR56	3 Contact Lugs	12.8	65W	SAE	400	49	6
							12.8	42W		2,000		
	19411	19556	576	H5051	165mm	2 Contact Lugs	12.8	50W	SAE	500	44	26
	19429	19558	448	H5054	200mm	3 Contact Lugs	12.8	65W	SAE	400	45	4
							12.8	42W		2,000		
	19412	19557	576	H5062	165mm	3 Contact Lugs	12.8	40W	SAE	400	44	20
							12.8	55W		2,000		
		41453	48	H3660*	140mm	2 Right Angle Lugs	12.8	37.5W	2,000	900	44	2
	18525			H6024	PAR56	3 Contact Lugs	12.8	65W	SAE	150	49	7
							12.8	35W		320		
	18534	11545	448	H6054	200mm	3 Contact Lugs	12.8	65W	SAE	150	45	5
							12.8	35W		320		
	14752			H6054HO	200mm	3 Contact Lugs	12.8	65W	SAE	150	45	6
							12.8	55W		700		
	45477			H6054SB*	200mm	3 Contact Lugs	12.8	65W	SAE	75	45	7
							12.8	55W		200		
	43561	43562	60	H7550	PAR36	Screw Terminals	6.0	8W	25,000	50	45	15
		23541	60	H7550-1	PAR36	Slip-on Terminals	6.0	8W	25,000	50	45	16
	43564	43565	60	H7551	PAR36	Screw Terminals	6.0	8W	550	50	45	17
	43567			H7552	PAR36	Screw Terminals	6.0	10W	650	50	45	18
	43570	43571	60	H7553	PAR36	Screw Terminals	6.0	12W	850	50	45	19
		43574	60	H7554	PAR36	Screw Terminals	6.0	20W	1,400	50	45	20
	44642	44643	60	H7555	PAR36	Screw Terminals	12.0	8W	550	50	45	28
	44924	44925	60	H7556	PAR36	Screw Terminals	6.0	6W	400	50	45	11
	12720	12721	60	H7557	PAR36	Screw Terminals	12.0	12W	850	50	45	31
	42841	42842	60	H7600	PAR36	Screw Terminals	12.8	37.5W	60,000	300	46	21
	43576	43577	60	H7604	PAR36	Screw Terminals	12.8	50W	100,000	100	46	27
	14616	43580	60	H7606	PAR36	Screw Terminals	12.8	50W	1,000	400	46	28
		17672	60	H7607	PAR36	Screw Terminals	12.8	65W	1,500	600	46	33
	14617	43583	24	H7609	PAR46	Screw Terminals	12.8	50W	2,200	400	48	3
	14618	43586	60	H7610	PAR36	Screw Terminals	12.8	50W	5,200	400	46	29
	49695			H7612	PAR46	Screw Terminals	12.8	37.5W	15,000	450	47	37
	49731	49732	60	H7614	PAR36	Screw Terminals	12.8	50W	2,000	100	46	30
	42838	42839	60	H7616	PAR36	Screw Terminals	12.8	37.5W	70,000	300	46	22
	14619	43589	24	H7619	PAR46	Screw Terminals	12.8	50W	6,000	400	48	4

*New lamp added since last publication. Turquoise—Halogen Lamps

INDEX – SEALED BEAM LAMPS

Order Code			Bulk Std. Pkg. Qty.	Lamp No.	Bulb	Base	Design		Mean Spherical Candlepower (Approx.)	Rated Avg. Lab Life (Hours)	Page No.	Line No.
Blister Pack	Unit Pack	Bulk Pack					Volts	Watts or Amps				
		45058	24	H7621-1	PAR46	Slip-on Terminals	12.8	50W	20,000	200	48	5
	43591	43592	24	H7635	PAR46	Screw Terminals	12.8	50W	160,000	100	48	6
		18022	24	H7635X	PAR46	Screw Terminals	12.8	50W	160,000	100	48	7
	17894	17890	24	H7680HIR	PAR46	Screw Terminals	13.0	80W	275,000	100	48	9
	26694	26695	24	H7680XHIR*	PAR46	Screw Terminals	13.0	80W	230,000	300	48	10
		23250	16	H7913HIR	165mm	2 Contact Lugs	12.8	65W	4,000	800	45	1
		13426	16	H7921-1	165mm	Slip-on Terminals	12.8	50W	23,900	200	44	27
	47460	14892	16	H7935-1	165mm	Slip-on Terminals	12.8	50W	175,000	100	44	28
2	15767	15763	48	H9405	150mm	2 Right Angle Lugs	12.8	50W	100,000	100	44	8
	15769	15768	48	H9406	150mm	2 Right Angle Lugs	12.8	50W	1,350	400	44	9
	15771	15770	48	H9411	150mm	2 Right Angle Lugs	12.8	50W	5,400	400	44	10
		15772	48	H9414	150mm	2 Right Angle Lugs	12.8	50W	2,700	400	44	11
	16484	16483	48	H9415	150mm	2 Right Angle Lugs	12.8	37.5W	12,000	200	44	6
	17988			H9415A	150mm	2 Right Angle Lugs	12.8	37.5W	—	200	44	7
	16976	16978	48	H9420	150mm	2 Right Angle Lugs	12.8	50W	47,000	200	44	12
	16482			H9421	150mm	2 Right Angle Lugs	12.8	50W	4,000	200	44	13
	22109			Q4509	PAR36	Screw Terminal	13.0	100W	140,000	100	46	39
	37706			Q4554	PAR46	Screw Terminals	28.0	450W	65,000	100	48	33
	40579			Q4559	PAR64	Screw Terminals	28.0	600W	600,000	100	49	13
	42552			Q4559X	PAR64	Screw Terminals	28.0	600W	765,000	100	49	14
	41097			Q4566	PAR46	Screw Terminals	28.0	450W	150,000	1,000	48	34
	37372			Q4597	PAR46	Screw Terminals	28.0	450W	16,000	1,000	48	35
	40577			Q4629	PAR64	Screw Terminals	28.0	600W	20,000	1,000	49	15
	34537			Q4631	PAR36	Screw Terminals	13.0	250W	80,000	500	47	2
	39112			Q4632	PAR36	Screw Terminals	13.0	250W	75,000	500	47	3
	36271			Q4681	PAR46	Screw Terminals	28.0	450W	310,000	50	48	36
	41452			Q5551*	PAR46	Screw Terminals	28.0	250W	60,000	100	48	28
	16784			Q5559*	PAR64	Screw Terminals	28.0	600W	650,000	200	49	16

*New lamp added since last publication. Turquoise-Halogen Lamps

EUROPEAN AUTOMOTIVE CROSS-REFERENCE

In Europe, exterior automotive lamps are regulated by ECE Regulation 37, and other regulations particular to the application. Many other countries have adapted the ECE regulations. GE's global facilities produce a full line of ECE types in 6, 12, and 24 volts. Due to demand, not all types are currently stocked in North America; therefore, some types are not included in this catalogue. Call your GE sales office for further information.

In Europe, manufacturers do not have a common lamp number. Below is a cross reference of the most common 12 volt ECE types.

Many trucks built in Europe use 24 volt systems. Below is a cross reference of the most common 24 volt ECE types. Usage of these vehicles in North America is limited.

12V ECE REGULATION 37 TYPES

Application	ECE Type	Manufacturer Numbers			
		GEUS	GE Europe	Osram	Philips
Headlamps & Foglamps	H1	50310/1	50310/1	64150	12258
	H2	50410	50410	64173	12311
Foglamps	H3	50340	50340	64151	12336
	H4	50440	50440	64193	12342
	H7	H7	58520	64210	
Signaling	H27W/1	880			
	H27W/2	881			
	R2		1931	7951	12620
	P21W ¹	P25-1	1057	7506	12498
	P21/5W	P25-2	1077	7528	12499
	P21/4W		1122	7225	12594
	PY21W ²		1056	7507	12496
	R5W ¹	R5W	2619	5007	12821
	R10W ¹	R10W	2641	5008	12814
	T4W	T4W	2662	3893	12929
	C5W	C5W	7546	6418	12844
W3W	W3W	5304	2821	12256	
W5W	W5W	5307	2825	12961	
W16W	W16W				

24V ECE REGULATION 37 TYPES

Application	ECE Type	Manufacturer Numbers			
		GEUS	GE Europe	Osram	Philips
Headlamps & Foglamps	H1	50320/1	50320/1	64155	13258
	H2		50420	64175	13311
Foglamps	H3	50350	50350	64156	13336
	H4	50450	50450	64196	13342
Signaling	R2		1937	7952	13620
	P21W ¹	1060	1060	7511	13498
	P21/5W		1078	7537	13499
	R5W ¹	2627	2627	5627	13821
	R10W ¹		2643	5637	13814
	T4W		2661	9930/3930	13929
	C5W		7552	6423	13844

¹With SC Bayonet (Ba15s) Base

²With SC Bayonet (Ba15s) Base

¹With (BAV 15s) Base

HIGH OUTPUT HALOGEN-CYCLE LAMP INFORMATION

Benefits of halogen-cycle lamps:

Higher Light Output from Less Energy and a Smaller Lamp Package

- Typical halogen-cycle miniature lamp rated at 45 watts produces as much light as a standard 60-watt household bulb... yet the halogen-cycle lamp is $\frac{1}{6}$ the size of the household lamp.

Higher Maintained Light Output Over Life

- Can be operated at high wattages without sacrificing the light output over life.
- Most halogen-cycle lamps produce 85 to 95% of their initial light output at 70% of their life expectancy.
- Bulb blackening due to tungsten deposits on the bulb wall virtually eliminated.

Available in Full Range of Types and Sizes

- GE halogen-cycle lamps are available in voltages ranging from 4 to 32.
- Candlepower ranges from 3.8 to 660.
- Lamp sizes range from 7.5mm subminiature to 16mm miniature diameters.
- Sockets for GE halogen-cycle lamps are commercially available from a number of manufacturers.*

* For Halogen Lamp Types see "Turquoise Lamp Number" in Miniature & Sealed Beam Lamp Specifications.

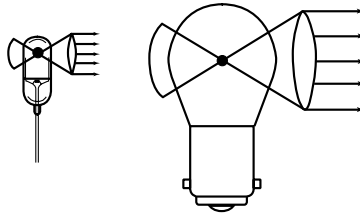

Halogen-cycle lamp versus conventional incandescent lamp of equivalent wattage. Note the smaller size of the halogen lamp on the left.

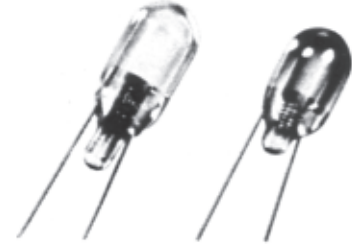

Halogen-cycle lamp versus vacuum incandescent lamp at 70% lamp of life. Note the bulb blackening of the incandescent lamp on the right.

HALOGEN LAMPS & SEALED BEAM - DESIGN FEATURES

GE Manufactures Four Types of Halogen-Cycle Lamps:

Glass Halogen Miniature Lamps

- Increased range in candlepower and wattages of these halogen-cycle lamps allows for many new and current design applications.
- Lamp design consists of a hemispherical bulb top with more uniform light output than a top-tipped halogen lamp.
- Sturdy nickel-plated iron leads in two-pin types allow for positive electrical connection, minimizing voltage drops due to intermittent connections.
- Although these lamps can be damaged by thermal shock, they are not subject to devitrification.
- Electrical connections to lamps offered with molybdenum leads can be made by crimping or welding.

Quartzline® Fused-Quartz Miniature Lamps

- Normally used in special applications, but can also be used in many general applications if the designer chooses.
- Can withstand thermal shock - i.e. it will not crack or break even when suddenly exposed to water or ice.

Glass Halogen and Quartzline® Fused-Quartz Sealed Beam Lamps

- Designated in this catalog by the prefixes "H" and "Q".
- Can be used in many applications to take advantage of their higher light output compared with standard incandescent sealed beam lamps.
- Standard PAR36, PAR46, PAR56, PAR64 & rectangle 140mm, 150mm, 165mm & 200 mm sizes allow possible use in existing housings.
- Several different beam patterns are available for a variety of applications.

Consider These Factors When Selecting GE Halogen-Cycle and High Wattage Lamps:

Lamp Efficacy and Operating Precautions.

Many lamps listed in this catalog are filled to high internal gas pressures to maximize lamp efficacy (candlepower or lumens per watt). Because both lamp bulb material and pressure vary by lamp design, different SAFETY notices apply. Be sure to read the appropriate notice(s) for the lamp(s) you select.

High Operating Temperatures

Because operating temperatures (watts plus environment) are critical to the effectiveness of the self-cleaning properties of halogen-cycle lamps, bulb wall temperatures should not go below 250°C. Hot spots on the bulb wall itself can go as high as 700°C in normal operation. Substantial heat is generated in all halogen-cycle lamps, so allowances should be made for the dissipation of excessive heat in equipment design. Certain lamps and extremely confined fixtures may require additional ventilation or heat sinking to ensure proper operation of the halogen cycle and prevent damage to the fixture. It is a good practice to test the lamp in the operating environment early in the design cycle to ensure adequate performance. Precautions must be taken in the selection of materials for lampholders, reflectors, and lamp housings because the 700°C bulb wall temperature is greater than the kindling temperatures of many materials. Lamp base temperatures should not exceed 350°C because, above that point, lead wires may deteriorate and the basing cement may loosen, causing premature lamp failure.

Distribution of Spectral Radiation

Halogen-cycle lamps offer great amounts of visible and infrared energy from a small light source, with about 90% of the energy in the infrared. Some GE lamps can be used for special applications where small amounts of ultraviolet energy are required.

DESIGN FEATURES - MINIATURE LAMPS

Consider These Factors When Selecting GE Miniature Lamps:

Light Quantity and Quality

Where an object or surface is to be illuminated, the quantity of light required depends upon the size of the object, the brightness desired, the contrast with its background, and the time available for seeing.

Where light must be projected, either a separate reflector and lamp or a reflectorized lamp may be required. Consideration should be given to beam candlepower and beam spread.

The spectral quality of color of light can be modified by external filters or coatings applied to the bulb.

Light, Life, and Voltage

For any particular lamp, the light output and life depend upon the voltage at which a lamp is operated. For instance, as approximations, the light output varies as the 3.6 power of the voltage and the life varies inversely as the 12th power of the voltage. Chart I and Table I illustrate the effect of overvoltage or undervoltage applied to a lamp on its current, life, and light (candlepower) output. Indicated values (except for long-life lamps) are reasonably valid, between 95% and 110% rated volts. Beyond that, indicated characteristics may not be realized because of the increasing influence of factors which cannot be incorporated into the chart. The chart applies only to D.C. or sine-wave A.C. current, considering the applicable footnotes pertaining to published life. The data, particularly for lamp life, do not apply accurately for lamp operation on half-wave rectified voltage, semi-conductor dimming devices, and constant-current operation.

Mechanical Strength

Low-voltage, high-current incandescent lamps are best suited for operation under conditions of shocks and vibration. Other factors affecting strength are the resonant frequency of lead wires and filament form. Where rough service conditions are encountered, screw base lamps should be avoided since they may loosen in their sockets. Higher voltage lamps of similar light output and life have longer, thinner filaments which are more prone to shock and vibration failures.

Power Sources

In battery applications, the mean effective voltage delivered is generally higher than the average volts. The mean effective voltage, therefore, should be the design voltage of the lamp. Design voltages for flashlight lamps have been determined by extensive tests.

Filament lamp ratings are predicated on operation at a constant voltage. When operated from a higher-than-rated voltage in series with a dropping resistor, the effect is the same as operating at a constant current. Since the lamp resistance changes with operating life, the voltage drop across the lamp will increase; hence, the lamp life experienced will generally be about one half that resulting from constant-voltage operation.

When selecting a transformer or resistor, consideration should be given to lamp ampere tolerances and the regulation characteristics of the component.

Since integrated circuit applications are operated on D.C. and, in general, constant current, lamps used with them offer less life than applications where A.C. voltage and higher current can be tolerated. This is because the D.C. notching phenomenon occurs in greater percentage on low-current lamps, and the life is approximately 50% under constant current than that under controlled voltage. This half-life on constant current occurs because the filament is evaporating and becoming smaller as the lamp is operating, gradually increasing in resistance and requiring a rise in voltage to maintain a constant current value. This, in turn, increases the wattage and the filament temperature, causing an increase in the efficiency of the lamp.

Space

Tolerances of bulb diameters, light center lengths, and overall lengths should be carefully considered by designers when specifying lamp housings. These tolerances and more-detailed drawings are available from your local GE Lamp Representative.

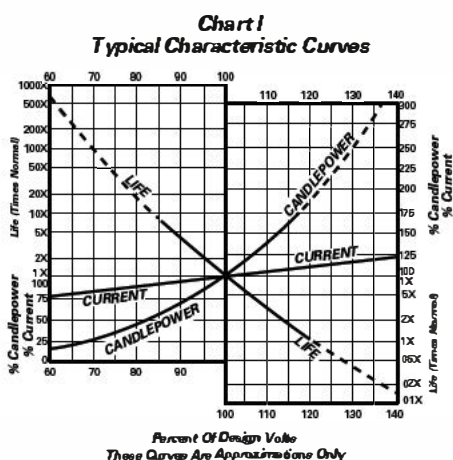

Table I

Underrated Bulb Voltages (100% <=)				Overrated Bulb Voltages (100% >=)			
Volts %	Amprs %	MSCP %	Life %	Volts %	Amprs %	MSCP %	Life %
99	99.4	96.5	112.8	101	100.5	103.5	88.7
98	98.9	93.2	127.4	102	101.1	107.2	78.8
97	98.3	89.9	144.1	103	101.6	110.9	70.1
96	97.8	86.7	163.2	104	102.2	114.7	62.5
95	97.2	83.6	185.1	105	102.7	118.6	55.7
90	94.4	69.2	354.1	110	105.4	139.6	31.9
85	91.4	56.6	703.0	115	108.0	163.1	18.7
80	88.5	45.8	1455.2	120	110.5	189.3	11.2
75	85.4	36.5	3156.9	125	113.1	218.4	6.9
70	82.2	28.7	7224.8	130	115.5	250.5	4.3

NOTE: Calculations of characteristics shown in Chart I and Table I are approximate only between 95% and 110% of rated voltage for lamp types with 5,000 hours life or less. Certain lamp types will vary widely from calculated values. This chart will not apply to lamps with lives in excess of 5,000 hours or to halogen-cycle lamps. Consult your local GE Lamp Representative for application information.

Ambient Temperature

It is important to consider the lamp housing from the standpoints of radiation, absorption, and ventilation. Normal variations in ambient temperature do not affect the performance of miniature lamps. Above 175°C (350°F), the solder on conventional lamps may soften, deform, or melt, and the basing cement may loosen. All-glass wedge base lamps can be operated in lamp ambient temperatures of up to 230°C (450°F).

Inrush Current

The initial current through a filament is called the inrush current. Cold resistance of a filament is generally considered to be that of room temperature, while the hot resistance depends upon the temperature of the filament (which varies with lamp size). Inrush current can be approximately 12 times as great as the normal operating current. This maximum value is seldom reached because the impedance in the circuit reduces it. However, equipment designers should take both inrush current and resistance into consideration when selecting a lamp. Chart II displays the general range of inrush current versus time after voltage is applied to a cold lamp. Inrush current can be reduced by applying a low value of pre-heat voltage.

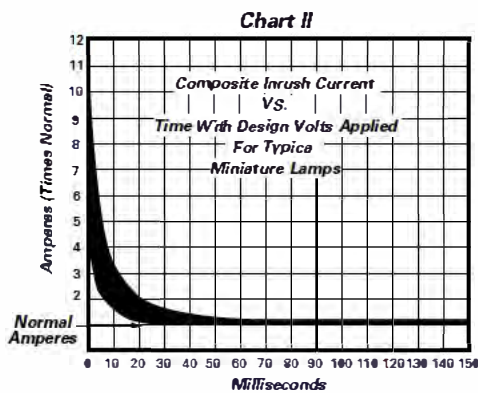

Tungsten filaments are more fragile at temperatures below the 250°C brittle-ductile region. This fragility can be reduced by using a keep-alive voltage or current in the off condition. A general recommendation for keep-alive requirements is 25% of the design voltage or current. This will reduce the inrush current from approximately 12 times to 4 times, depending upon the lamp type.

Incandescence and Nigrescence

The rate of rise and decay time depends upon the mass of the filament to be heated. In general, the incandescence (rise time) to 90% brightness is about 100 to 300 milliseconds, and the nigrescence (decay time) is about 40 to 100 milliseconds. These values vary with each lamp type. The times are directly related to the lamp current; therefore, low-current lamps have the fastest response times.

Flashing and Pulsing

Incandescent lamps have been used successfully in flashing and pulsing circuits. However, this may affect lamp life in some cases. For more information, contact your local GE Lamp Representative.

Redundant System Philosophy

Two-filament lamps with filaments connected in parallel for additional reliability are not new. Experience has shown, however, that in many cases, the second filament has failed by the time it is needed. Thus, these lamps have never become very popular.

A more reliable system would be to use two or more lamps operating at the same time. Since they are physically separated from each other, it is easy to see when one has failed. This lamp can be replaced immediately, prior to the failure of the second lamp.

Color Temperature

The radiation from tungsten filaments used in General Electric lamps is similar to that from a "black body" at specific temperatures. This can be determined approximately from Chart III. Use the published lamp ratings (or estimated derated values) in this catalog. The catalog indicates whether a lamp is vacuum or gas-filled.

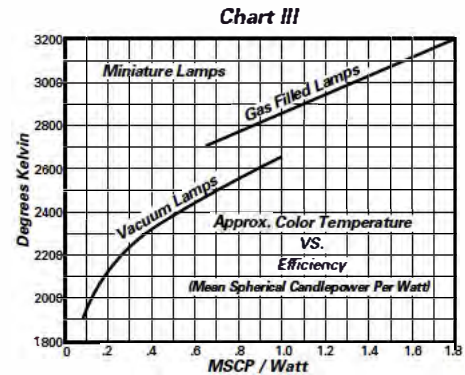

Lamp Life

Rated average life is that obtained in closely controlled laboratory testing of lamps on 60 Hertz Alternating Current at their design voltage. Certain lamps are tested with Direct Current and are footnoted accordingly. Very long life lamps are generally rated on the basis of extrapolated laboratory test data. Service conditions such as shocks, vibration, voltage fluctuations, temperature, etc., may contribute to a shorter average service life.

Ordinarily, for still-rack operation, normal tungsten filament evaporation is the basic force or mechanism controlling incandescent lamp life. Where normal filament evaporation is the dominant failure mechanism, lamps should reach their design-predicted lifetimes.

Another filament mechanism has been identified which may reduce life to one-half or much less of its design-predicted value. It is commonly referred to as "filament notching." Notching is the appearance of step-like or sawtooth irregularities, appearing on all or part of the tungsten filament surface, after extensive (e.g. 3000Hrs) burning.

These notches reduce the filament wire diameter at various points. In some cases, especially in fine-wire diameter lamps, the notching is so severe as to almost penetrate the entire wire diameter. Thus accelerated spot evaporation due to this notching (as well as reduced filament strength) now becomes the dominant mechanism for influencing lamp life. Because of its abnormal evaporation and/or reduced strength effects, lamp lifetimes due to notching are substantially lessened.

Notching has been due to at least three factors:

1. Low-temperature filament operation, less than that for significant normal tungsten evaporation.
2. Small filament-wire sizes, less than one mil (.001") diameter in many cases, typical of low-ampere lamps.
3. Increased use of D.C. voltage operation

Subminiature lamps, those with bulb sizes of T-2 and below, have been the most susceptible candidates for filament notching. Since notching is very difficult to predict, it is recommended that lamps susceptible to this phenomenon be easily replaceable in their applications.



An example of filament notching.

MINIATURE FILAMENTS AND BASES

Filaments

Filaments for miniature and subminiature lamps may be a straight wire (S), a coil (C), or a coiled coil (CC). Coiling the filament wire effectively shortens the filament length so that smaller bulbs can be used. In addition, in gas-filled lamps, coiling the wire reduces thermal losses and increases efficiency.

Tungsten is almost universally used as lamp filament material because of its high melting point at incandescence. The number following the coil identification letter(s) denotes the arrangement of the filament on the supports.

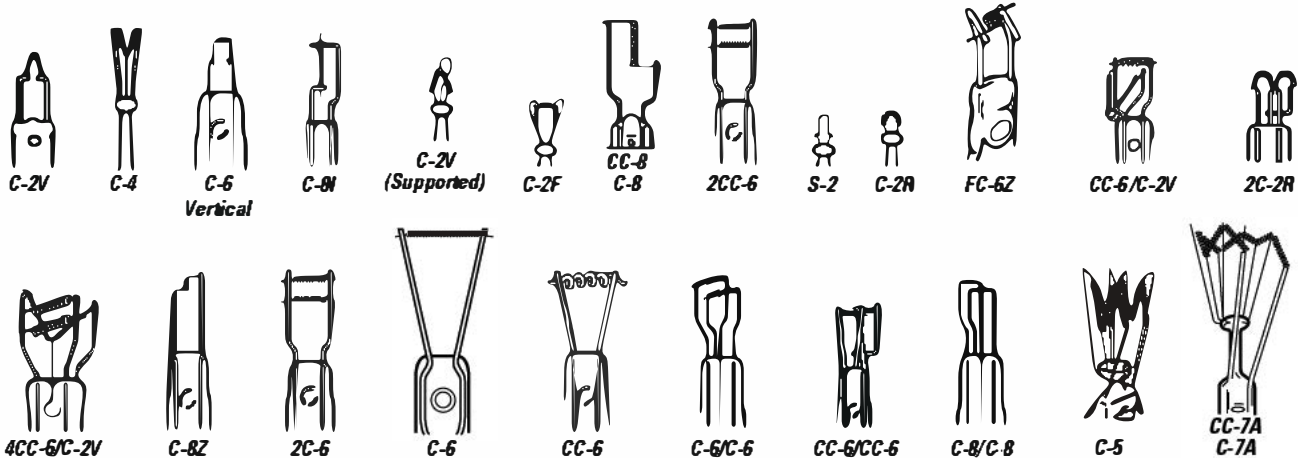

Bases

Bases provide electrical contact to the lamp and, in most cases, also support the lamp in the fixture. For miniature and subminiature lamps, bayonet or wedge base types are generally preferred over screw types

when vibration is present. In addition, wedge bases reduce socket size and complexity. Flanged or collared types are usually associated with requirements for filament location.

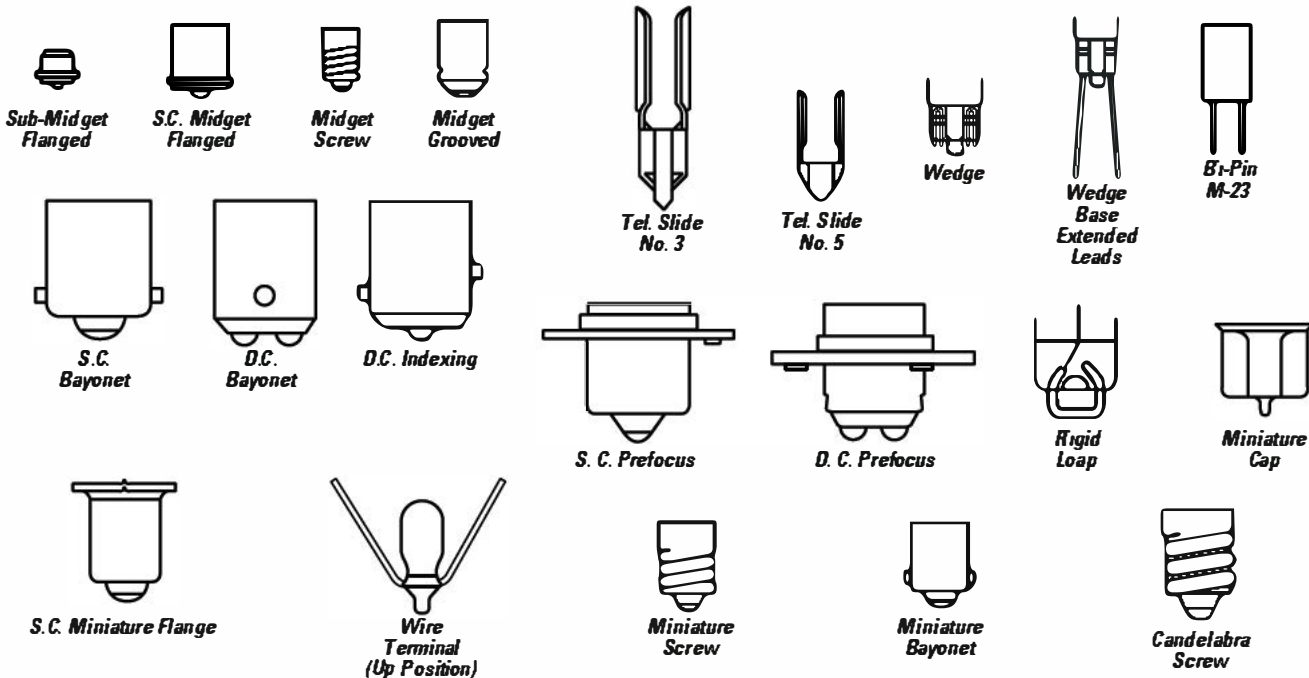

S.C. and D.C. Prefocused Base Lamps

The letter "A" following the base type designates that the distance from the bottom of the collar to the bottom of the base contact is $\frac{13}{32}$ ". For "B" bases this distance is $\frac{9}{16}$ ". The few lamps identified by the letter "S"

in the "Base" column are special in that the collar location and/or the orientation of the contacts differs from the above.

MINIATURE LAMP SPECIFICATION

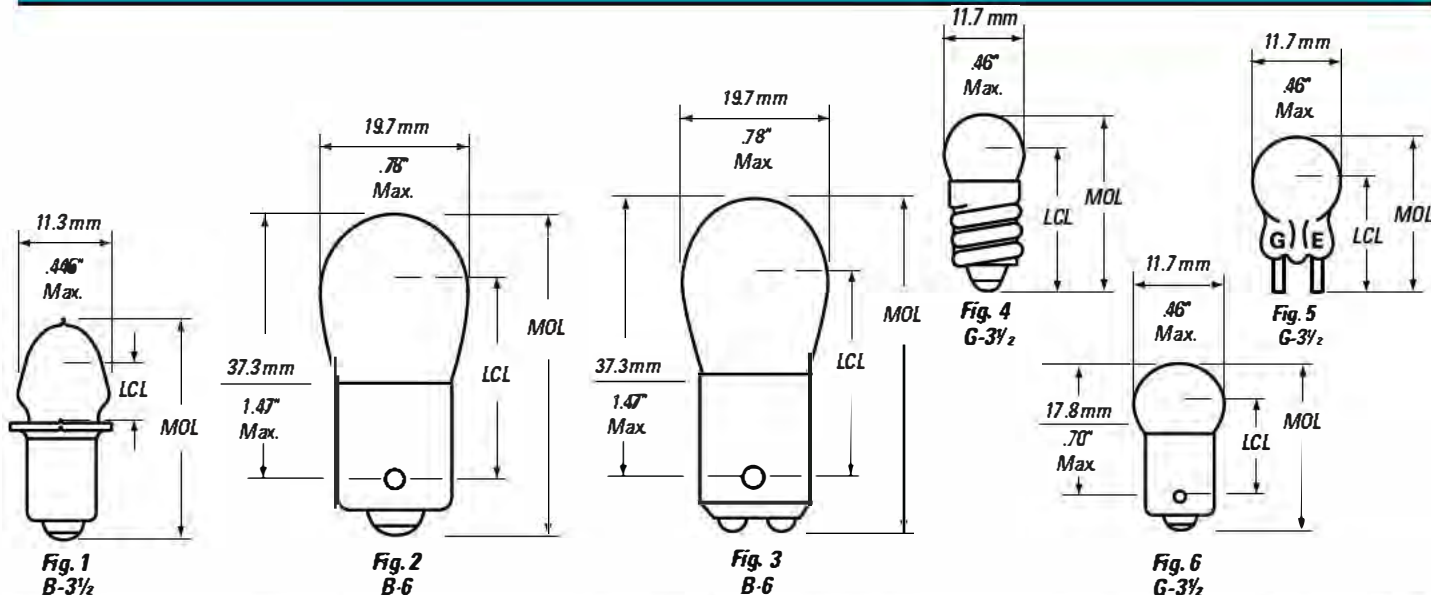

Line No.	Order Code			GE Lamp No.	Primary Application	Safety Notes	Design Volts	Design Watts or Amps	Mean Spherical CP (Approx.)	Base	Atmosphere B-Vac./C-Gas	Filament Designation	Light Center Length (in.)	Max. Overall Length (in.)	Rated Average Lab Life (Hours)	Fig. No.
	Blister Pack	Unit Pack	Bulk Pack													
B-3 1/2 BULB 7/16" (11mm) DIAMETER																
1	23151			KPR104	Flashlight - 2D Krypton		2.2	.47A	.47	S.C. Miniature Flanged	C	C-2R	.25	1.25	15 (116)	1
2	12677			PR4	Flashlight - 2C Cells		2.33	.27A	.4	S.C. Miniature Flanged	B	C-2R	.25	1.25	10 (116)	1
3	12675	25181		PR2	Flashlight - 2D Cells		2.38	.50A	.8	S.C. Miniature Flanged	B	C-2R	.25	1.25	15 (116)	1
4	22961			KPR102	Flashlight - 2D Krypton		2.4	.70A	1.3	S.C. Miniature Flanged	C	C-2R	.25	1.25	15 (116)	1
5		25222		PR6	Flashlight - 2D Industrial Cells		2.47	.30A	.45	S.C. Miniature Flanged	B	C-2R	.25	1.25	30 (116)	1
6	12676	25193		PR3	Flashlight - 3D Cells		3.57	.50A	1.5	S.C. Miniature Flanged	B	C-2R	.25	1.25	15 (116)	1
7		25235		PR7	Flashlight - 3D Industrial Cells		3.70	.30A	.9	S.C. Miniature Flanged	B	C-2R	.25	1.25	30 (116)	1
8	12681	25262		PR13	Hand Lantern - 4F Cells		4.75	.50A	2.2	S.C. Miniature Flanged	C	C-2R	.25	1.25	15 (116)	1
9	23153			KPR113	Flashlight - 4D Krypton		4.8	.75A	4.1	S.C. Miniature Flanged	C	C-2R	.25	1.25	20 (116)	1
10	12680	25252		PR12	Flashlight - 5D Cells		5.95	.50A	3.1	S.C. Miniature Flanged	C	C-2R	.25	1.25	15 (116)	1
11	23154			KPR118	Flashlight - 6D Krypton		7.2	.55A	5.2	S.C. Miniature Flanged	C	C-2R	.25	1.25	15 (116)	1
12		25289		PR18	Flashlight - 6D Cells (14)		7.20	.55A	5.5	S.C. Miniature Flanged	C	C-2R	.25	1.25	3 (116)	1
B-6 BULB 3/4" (19mm) DIAMETER																
13		34265		1317	Aircraft Emergency Lighting		6.00	.51A	3.4	S.C. Bayonet	C	C-6	1.12	1.75	100 (116)	2
14		25988		210	Instrument		6.5	1.78A	15	D.C. Bayonet	C	C-6	1.06	1.75	100	3
15	12367	26709		1003	Auto Interior		12.8	.94A	15	S.C. Bayonet	C	C-6	1.06	1.75	200	2
16	47800			1003KR*	Auto Interior - Krypton Fill. Long Life		12.8	.94A	15	S.C. Bayonet	C	C-6	1.06	1.75	400	2
17	12373	26726	26728	1004	Auto Interior and Marine		12.8	.94A	15	D.C. Bayonet	C	C-6	1.06	1.75	200	3
18		36147		105	Auto Interior - Heavy Duty		12.8	1.00A	12	S.C. Bayonet	C	C-6	1.06	1.75	500	2
19		27118		1309	Aircraft Interior. Reading, Dome, Map Light		28.0	.9A	15	S.C. Bayonet	C	2C-2R	1.06	1.75	300	2
20		12824		1308	Aircraft Reading Light Spiral Leads. Krypton.		28.0	.56A	16	S.C. Bayonet	C	CC-8	1.06	1.75	2,000	2
G-3 1/2 BULB 7/16" (11mm) DIAMETER																
21		25354		14	Flashlight - 2D Cells		2.47	.30A	.5	Miniature Screw	B	C-2R	.72	.94	15 (116)	4
22		25312		10	Indicator (69)		2.50	.50A	.5	Miniature Two Pin	B	C-6	.62	.94	3,000	5
23		25331		13	Flashlight - 3D Cells		3.70	.30A	.98	Miniature Screw	B	C-2R	.72	.94	15 (116)	4
24		25319		12	Radio (69)		6.30	.15A	.35	Miniature Two Pin	B	C-6	.62	.94	5,000 (44)	5
25		25529		51	Indicator		7.50	.22A	1	Miniature Bayonet	B	C-2R	.50	.94	1,000	6
26		27252		1449	Toy Train		14.0	.20A	2	Miniature Screw	B	C-2V (13)	.72	.94	250	4
27		25377	25379	19	Toy Train (69)		14.40	.10A	.9	Miniature Two Pin	B	C-6	.62	.94	1,000	5

13. Supported.

14. This lamp is specially designed for a particular purchaser and may not be suitable for other uses because of its excessive wattage requirements for the bulb size.

44. At 6.6 volts.

69. Not recommended for new OEM applications - suggested for new design are wedge base lamps such as GE Lamp Numbers 259, and 161.

116. Life tests are performed on DC voltage only.

MINIATURE LAMP SPECIFICATION

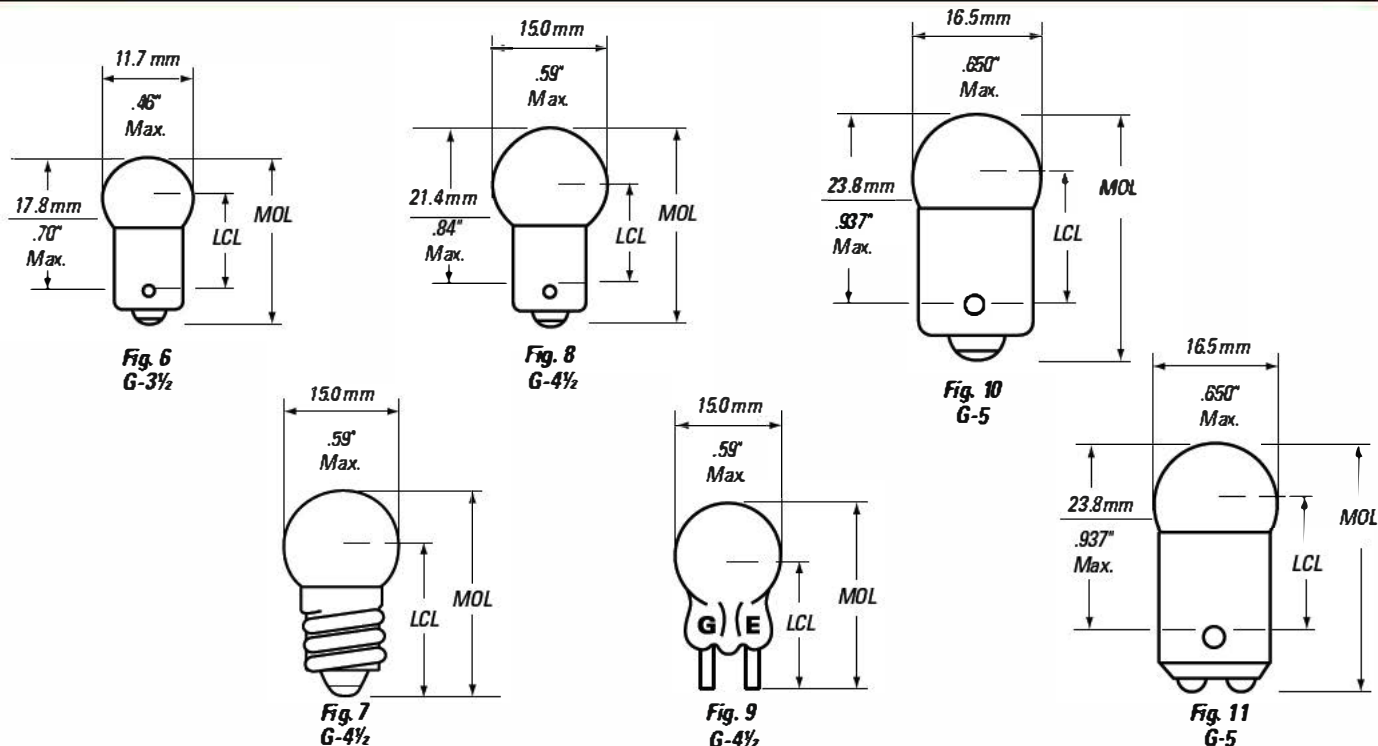

Line No.	Order Code			GE Lamp No.	Primary Application	Safety Notes	Design Volts	Design Watts or Amps	Mean Spherical CP (Approx.)	Base	Atmosphere B-Vac./C-Gas	Filament Designation	Light Center Length (in.)	Max Overall Length (in.)	Rated Average Lab Life (Hours)	Fig. No.
	Blister Pack	Unit Pack	Bulk Pack													
G-3 1/2 BULB 1/16" (11mm) DIAMETER (continued)																
1		25550	25552	53	Auto and Indicator		14.4	.12A	1	Miniature Bayonet	B	C-2V ⁽¹³⁾	.50	.94	1,000	6
2	12329	27207	27209	1445	Auto Toy Train Ratings		14.4	.135A	.7	Miniature Bayonet	B	C-2V ⁽¹³⁾	.50	.94	2,000	6
3		27263		1450	Indicator		18.0	.15A	1.5	Miniature Bayonet	B	C-2F	.50	.94	3,000	6
4		44719		265	Indicator		24.0	.035A	.23	Miniature Bayonet	B	C-2F	.50	.94	5,000	6
5		26255		356	Aircraft ⁽¹⁴⁾		28.0	.17A	3.5	Miniature Bayonet	B	C-2F	.50	.94	500	6
G-4 1/2 BULB 1/16" (14mm) DIAMETER																
6		25388		27	Hand Lantern - 4F Cells		4.9	.30A	1.4	Miniature Screw	B	C-2R	.72	1.07	30 ⁽¹¹⁶⁾	7
7		26354		425	Hand Lantern - 4F Cells		5.0	.50A	2.3	Miniature Screw	C	C-2R	.72	1.07	15 ⁽¹¹⁶⁾	7
8		26460		502	Hand Lantern - 4F Cells		5.1	.15A	.6	Miniature Screw	B	C-2R	.72	1.07	100 ⁽¹¹⁶⁾	7
9		26549		605	Flashlight - 5D Cells		6.15	.50A	3.4	Miniature Screw	C	C-2R	.72	1.07	15 ⁽¹¹⁶⁾	7
10		25371		15	Indicator ⁽⁶⁹⁾		7.0	.40A	2	Miniature Two Pin	C	C-6	.69	1.07	500	9
11		25576		55	Instrument		7.0	.41A	2	Miniature Bayonet	C	C-2R	.56	1.07	500	8
12	23218	25591	25593	57	Auto and Instrument		14.0	.24A	2	Miniature Bayonet	B	C-2V ⁽¹³⁾	.56	1.07	500	8
13		26095		258	Toy Train, Flasher Lamp ⁽⁷⁰⁾		14.0	.27A	1.6	Miniature Screw	C	C-2R	.81	1.07	500 ⁽⁸⁾	7
14	12330	27945	27948	1895	Auto, Truck Marker		14.0	.27A	2	Miniature Bayonet	B	C-2F	.56	1.07	2,000	8
15		32688		293	Auto and Radio		14.0	.33A	2	Miniature Bayonet	B	C-2F	.56	1.07	7,500	8
16		26441		456	Instrument		28.0	.17A	2	Miniature Bayonet	B	C-2F	.56	1.07	5,000	8
G-5 BULB 1/16" (16mm) DIAMETER																
17		32098		1315	Aircraft Emergency Lighting		2.5	1.00A	1.75	S.C. Bayonet	C	C-6	.69	1.25	20 ⁽¹¹⁶⁾	10
18		26112		301	Aircraft		28.0	.17A	3	S.C. Bayonet	B	C-2F	.69	1.25	500	10
19		26120		302	Aircraft		28.0	.17A	3	D.C. Bayonet	B	C-2F	.69	1.25	500	11

3. Useful hours.

13. Supported.

14. This lamp is specially designed for a particular purchaser and may not be suitable for other uses because of its excessive wattage requirements for the bulb size.

69. Not recommended for new OEM applications - suggested for new design are wedge base lamps such as GE Lamp Numbers 259, and 161.

70. These lamps produce a random flashing indication only. While the majority should flash between 40-160 flashes per minute at normal room temperature, some will be outside this range. As ambient temperature and/or input voltage changes, the flash rate may vary considerably. At rated voltage and room temperature most lamps will flash within 60 seconds.

116. Life tests are performed on DC voltage only.

MINIATURE LAMP SPECIFICATION

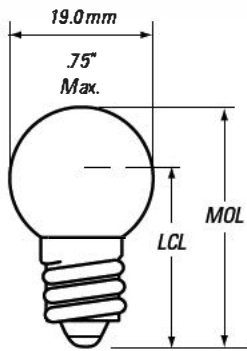

Fig. 12
G-6

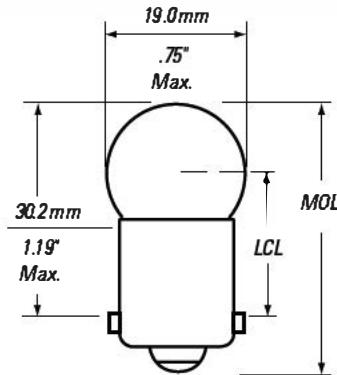

Fig. 13
G-6

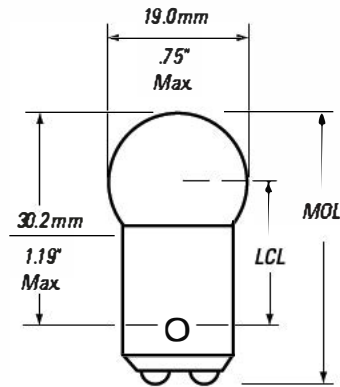

Fig. 14
G-6

Line No.	Order Code			GE Lamp No.	Primary Application	Safety Notes	Design Volts	Design Watts or Amps	Mean Spherical CP (Approx.)	Base	Atmosphere B-Vac./C-Gas	Filament Designation	Light Center Length (in.)	Max. Overall Length (in.)	Rated Average Lab Life (Hours)	Fig. No.
	Blister Pack	Unit Pack	Bulk Pack													
G-6 BULB 3/4" (19mm) DIAMETER																
1		25927		157	Medical		5.8	1.10A	8.1	Miniature Screw	C	C-2R	1.0 ⁽¹²⁾	1.22	50	12
2		25736		81	Auto, Aircraft, and Coin Machine		6.5	1.02A	6	S.C. Bayonet	C	C-2R	.75	1.44	500	13
3		25751		82	Auto and Marine		6.5	1.02A	6	D.C. Bayonet	C	C-2R	.75	1.44	500	14
4	12321			63	Coin Machine		7.0	.63A	3	S.C. Bayonet	C	C-2R	.75	1.44	1,000	13
5		25643		64	Aircraft and Marine		7.0	.63A	3	D.C. Bayonet	C	C-2R	.75	1.44	1,000	14
6	12363	25778	18618	89	Auto		13.0	.58A	6	S.C. Bayonet	C	C-2R	.75	1.44	750	13
7	47797			89KR*	Auto. Krypton Fill Long Life		13.0	.58A	6	S.C. Bayonet	C	C-2R	.75	1.44	1,500	13
8	12364	25794	25796	90	Auto and Marine		13.0	.58A	6	D.C. Bayonet	C	C-2R	.75	1.44	750	14
9		16287	16286	98	Auto, Heavy Duty		13.0	.62A	6	S.C. Bayonet	C	C-2V	.75	1.44	800	13
10	12324	25652	25654	67	Auto		13.5	.59A	4	S.C. Bayonet	C	C-2R	.81	1.44	5,000 ⁽⁴⁾	13
11		25692		68	Auto and Marine		13.5	.59A	4	D.C. Bayonet	C	C-2R	.81	1.44	5,000 ⁽⁴⁾	14
12		26955		1155	Auto, Truck Marker – Heavy Duty		13.5	.59A	4	S.C. Bayonet	C	2C-2R	.81	1.44	5,000 ⁽⁴⁾	13
13	12322	25836	25838	97	Auto – Heavy Duty		13.5	.69A	4	S.C. Bayonet	C	C-2V ⁽¹³⁾	.81	1.44	5,000 ⁽⁴⁾	13
14	23322		35417	R10W LL	Auto. ECE R10W GE 2641 – Long Life		13.5	10W	10.0	S.C. Bayonet	C	C-2R	.75	1.47	400	13
15	23314		30859	R5W LL	Auto. ECE R5W GE 2619 – Long Life		13.5	5W	4.0	S.C. Bayonet	B	C-2R	.75	1.47	500	13
16	23023	26570		631	Auto – Two filaments in series – Heavy Duty		14.0	.63A	6	S.C. Bayonet	C	2C-2R	.75	1.44	1,000	13
17		26485		509K	Indicator	303	24.0	.18A	2.8	Candelabra Screw	B	C-2R	.75	1.47	1,000	–
18		27092		1251	Instrument – Two identical supported filaments in series		28.0	.23A	3	S.C. Bayonet	B	2C-2V ⁽¹³⁾	.75	1.44	2,000	13
19		27097		1252	Instrument – Two identical supported filaments in series		28.0	.23A	3	D.C. Bayonet	B	2C-2V ⁽¹³⁾	.75	1.44	2,000	14
20		26127		303	Aircraft		28.0	.30A	6	S.C. Bayonet	B	C-2F	.75	1.44	500	13
21		26136		304	Aircraft		28.0	.30A	6	D.C. Bayonet	B	C-2F	.75	1.44	500	14
22		26561	26563	623	Instrument – Two supported filaments in series		28.0	.37A	6	S.C. Bayonet	B	2C-2V ⁽¹³⁾	.75	1.44	1,000	13
23		26567	26568	624	Marine – Two supported filaments in series		28.0	.37A	6	D.C. Bayonet	B	2C-2V ⁽¹³⁾	.75	1.44	1,000	14
24		27044		1224	Marine		34.0 ⁽¹⁴⁷⁾	.16A	3.8	D.C. Bayonet	B	C-2F	.69	1.44	500	14

4. At 14 volts.

13. Supported.

127. LCL measured to top of filament.

147. Differs from ANSI.

303. See page 50.

MINIATURE LAMP SPECIFICATION

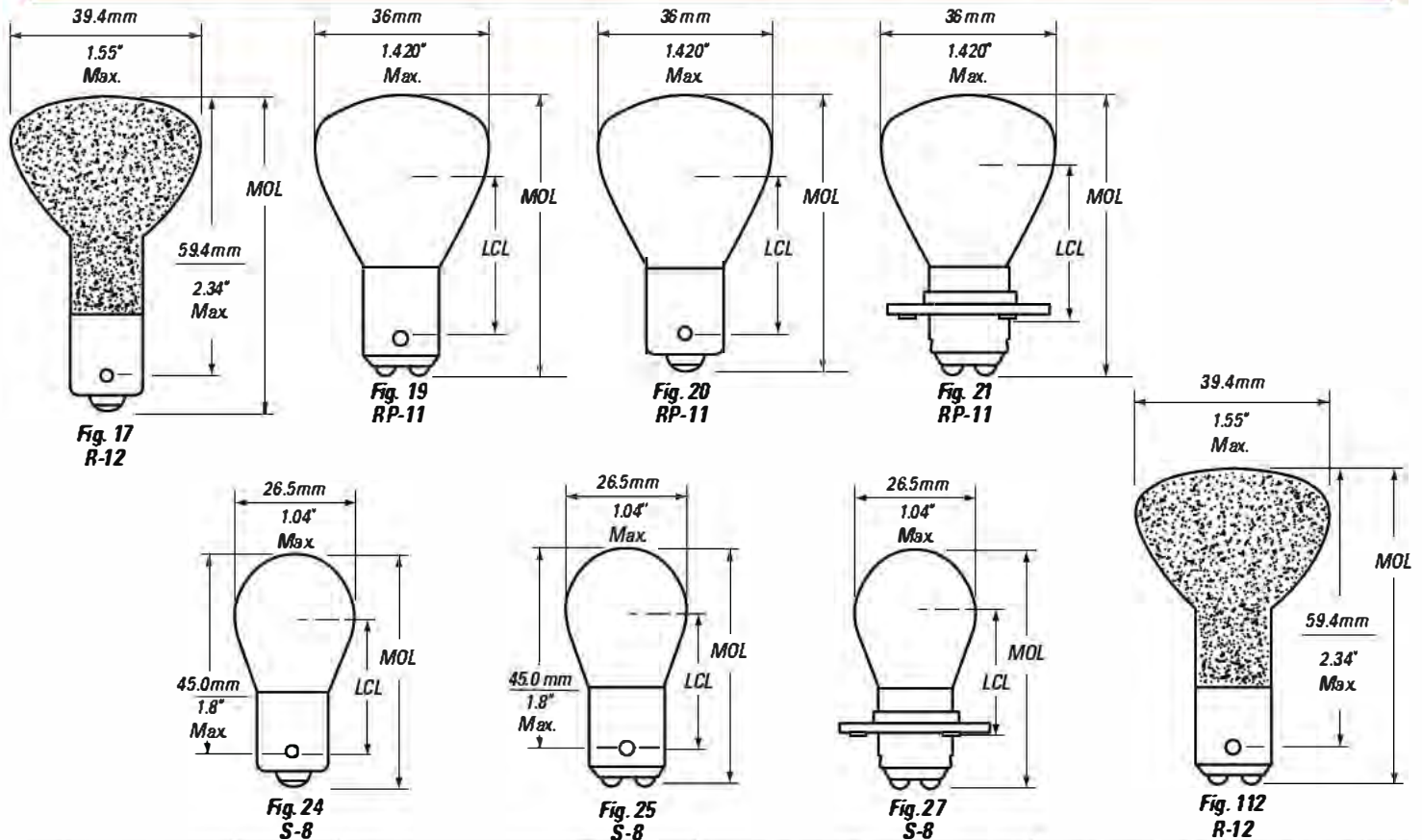

Line No.	Order Code			GE Lamp No.	Primary Application	Safety Notes	Design Volts	Design Watts or Amps	Mean Spherical CP (Approx.)	Base	Atmosphere B-Vac./C-Gas	Filament Designation	Light Center Length (in.)	Max. Overall Length (in.)	Rated Average Life (Hours)	Fig. No.
	Blister Pack	Unit Pack	Bulk Pack													
R-12 BULB 1/2" (38mm) DIAMETER																
1		27150		1383	Auto, Reading Light - Base half of bulb reflectorized		13.0	20W	-	S.C. Bayonet	C	C-8	-	2.63	300	17
2		27159		1388	Special Telephone Trouble - Base half of bulb reflectorized.		24.0	20W	-	D.C. Bayonet	C	CC-8	-	2.63	500	112
3		27154		1385	Special Reading Light - Base half of bulb reflectorized		28.0	20W	-	S.C. Bayonet	C	CC-8	-	2.63	300	17
RP-11 BULB 3/8" (35mm) DIAMETER Burning position - base down to horizontal.																
4		28100		2331	Instrument	305	5.9	4.66A	32	D.C. Pf. (S)	C	C-6	1.18	2.25	400	21
							6.2	4.49A	32						400	
5		26885		1133	Instrument	305	6.2	3.91A	32	S.C. Bayonet	C	C-2R	1.25	2.25	200	20
6		27021	27023	1195	Auto - Nickel-plated base	305	12.5	3.00A	50	S.C. Bayonet	C	C-2R	1.25	2.25	300	20
7		27026		1196	Auto	305	12.5	3.00A	50	D.C. Bayonet	C	C-2R	1.25	2.25	300	19
8		32147		1062	Special Service, Emer., Ltg	305	40.0	.92A	50	D.C. Bayonet	C	C-5	1.25	2.25	100	19
S-8 BULB 1" (25mm) DIAMETER																
9		27461		1612	Instrument (LCL & Actual Alignment tolerance + 3/64")		5.4	1.90A ⁽¹⁴⁷⁾	10	D.C. Bayonet	C	C-6	1.25	2.0	1,000	25
10		27548		1680	Aircraft		6.0	4.10A	32	S.C. Bayonet	C	C-6	1.25	2.0	300	24
11		33995		1680X	Aircraft - Solid Silver Contact		6.0	4.10A	32	S.C. Bayonet	C	C-6	1.25	2.0	300	24
12		37169		1096	Instrument, Microscope Illuminator		6.0	4.50A	30	D.C. Pf. (S)	C	C-2R	1.00	2.0	500	27
13		27305		1468	Medical Instrument - Burning position base up to horiz.		6.0	4.50A	30	D.C. Pf. (S)	C	C-2R	1.25	2.0	500	27
14		42677		1468X	Medical Instrument - Burning position base up to horiz.		6.0	4.50A	30	D.C. Pf. (S)	C	C-2R	1.25	2.0	500	27
15		27439		1594	Instrument, Microscope base down to horiz.		6.0	5.00A	36	D.C. Bayonet	C	C-6	1.25	2.0	250	25

147. Differs from ANSI.

305. See page 50.

MINIATURE LAMP SPECIFICATION

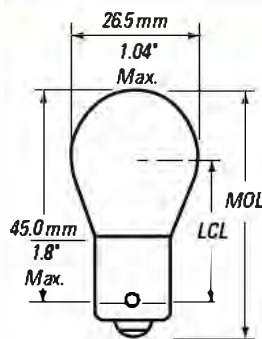

Fig. 24
S-8

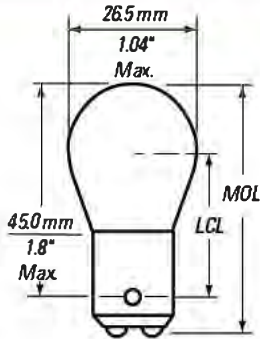

Fig. 25
S-8

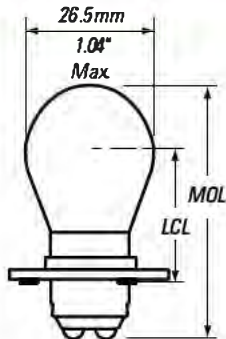

Fig. 27
S-8

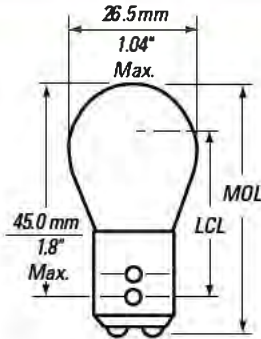

Fig. 28
S-8

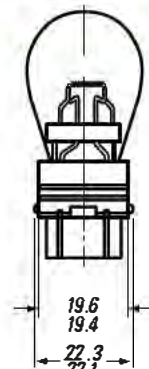

Fig. 30

Line No.	Order Code			GE Lamp No.	Primary Application	Safety Notes	Design Volts	Design Watts or Amps	Mean Spherical CP (Approx.)	Base	Atmosphere B-Vac./C-Gas	Filament Designation	Light Center Length (in.)	Max. Overall Length (in.)	Rated Average Lab Life (Hours)	Fig. No.
	Blister Pack	Unit Pack	Bulk Pack													
S-8 BULB 1" (25mm) DIAMETER (continued)																
1		26872		1129	Special Service		6.4	2.63A	21	S.C. Bayonet	C	C-6	1.25	2.0	200	24
2	12297			1154	Auto Stop, Tail, Signal		6.4	2.63A	21	D.C. Index	C	C-6	1.25	2	200	28
3		28310		1460	Medical		7.0	.75A	3						1,000	
4		37342	37343	1460X	Microscope Illuminator – Silver contacts		6.5	2.75A	23	D.C. Pf. (A)	C	C-6 ⁽¹¹⁾	1.25	2.0	100	27
5		27382		1493	Instrument, Microscope (L.C.L. & AA tolerance 3/64")		6.5	2.75A	23	D.C. Bayonet	C	C-6 ⁽¹¹⁾	1.12	2.0	100	25
6		27488	27489	1630	Instrument, Microscope		6.5	2.75A	23	D.C. Pf. (A)	C	C-6 ⁽¹¹⁾	1.00	2.0	100	27
7		27491		1631X	Instrument, Colorimeter – Illuminator Silver contacts		6.5	2.75A	23	D.C. Pf. (A)	C	C-6 ⁽¹¹⁾	1.00	2.0	100	27
8		27472		1619	Instrument		6.7	1.90A	15	S.C. Bayonet	C	C-6	1.12	2.0	500	24
9		25772		88	Indicator		6.8	1.91A	15	D.C. Bayonet	C	C-6	1.12	2.0	300	25
10	41755	22523		1295NA	Auto Signal		12.5	3.00A	37	S.C. Bayonet	C	C-2R	1.25	2.0	200	24
11	23217	25811	25813	93	Auto		12.8	1.04A	15	S.C. Bayonet	C	C-6 ⁽¹⁴⁾	1.12	2.0	700	24
12		25829	25831	94	Auto and Marine		12.8	1.04A	15	D.C. Bayonet	C	C-6 ⁽¹⁴⁾	1.12	2.0	700	25
13		26945		1152	Special Service		12.8	1.34A	21	D.C. Bayonet	C	C-2R	1.25	2	500	25
14		27004		1176	Auto Stop, Tail, Signal		12.8	1.34A	21	D.C. Bayonet	C	C-6	1.25	2.0	300	25
15	12346	26903	26905	1141	Auto		14.0	.59A	6						1,500	
16	47802			1141KR*	Auto. Krypton Fill. Long Life		12.8	1.44A	21	S.C. Bayonet	C	C-6	1.25	2.0	1,000	24
17		26917	26919	1142	Auto		12.8	1.44A	21	S.C. Bayonet	C	C-6	1.25	2.0	2,000	24
18		27630		1777	Aircraft Tail Light		12.8	1.92A	26	D.C. Bayonet	C	C-6	1.25	2.0	1,000	25
19	23028			3155	Auto Signal		12.8	1.60A	21	S.C. Bayonet	C	C-2R	1.12	2.0	400	24
20		26775		1034	Auto Stop Tail Signal		12.8	1.80A	32	Plastic Wedge	C	C-6	1.10	2.09	1,500	30
21							12.8	1.80A	32	D.C. Index	C	C-6	1.25	2	200	28
21	40134	26838		1073	Auto Signal		14.0	.59A	3						5,000	
22		26854		1076	Auto		12.8	1.80A	32	S.C. Bayonet	C	C-6	1.25	2.0	200	24
23	12344	26960	26962	1156	Auto Stop		12.8	1.80A	32	D.C. Bayonet	C	C-6	1.25	2.0	200	25
24	23334		11666	1156KR	Auto Stop. Krypton Fill. Long Life		12.8	2.10A	32	S.C. Bayonet	C	C-6	1.25	2.0	1,200	24
25							12.8	2.10A	32	S.C. Bayonet	C	C-6	1.25	2.0	2,400	24
25	21028	20248		1156NA	Auto Stop. Natural Amber		12.8	2.10A	24	S.C. Bayonet	C	C-6	1.25	2.0	1,200	24
26	12294	26969	26971	1157	Auto Stop, Signal		12.8	2.10A	32	D.C. Index	C	C-6	1.25	2.0	1,200	28
27							14.0	.59A	3						5,000	
27	23337			1157KR	Auto Stop, Signal. Krypton Fill. Long Life		12.8	2.10A	32	D.C. Index	C	C-6	1.25	2.0	2,400	28
28							14.0	.59A	3						10,000	
28	12310	26975	26976	1157NA	Auto Stop, Signal – Natural Amber		12.8	2.10A	24	D.C. Index	C	C-6	1.25	2.0	1,200	28
29							14.0	.59A	2.2						5,000	
29	47798			1157NAKR*	Auto Stop, Signal – Natural Amber. Krypton Fill. Long Life		12.8	2.10A	24	D.C. Index	C	C-6	1.25	2.0	2,400	28
							14.0	.59A	2.2						10,000	

11. Vertical

147. Differs from ANSI.

MINIATURE LAMP SPECIFICATION

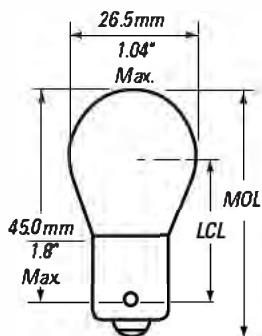

Fig. 24
S-8

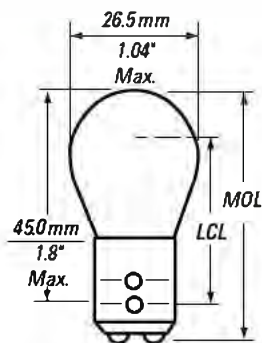

Fig. 28
S-8

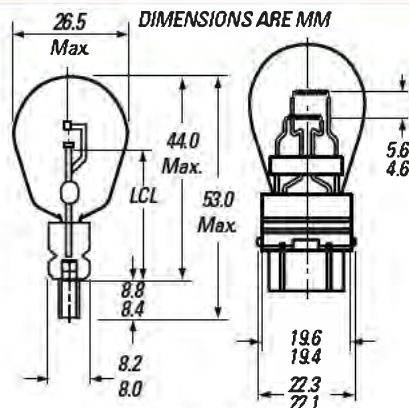

Fig. 29
S-8

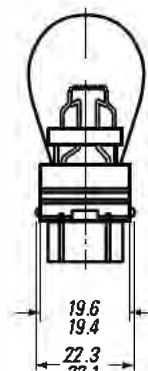

Fig. 30

Line No.	Order Code			GE Lamp No.	Primary Application	Safety Notes	Design Volts	Design Watts or Amps	Mean Spherical CP (Approx.)	Base	Atmosphere B-Vac./C-Gas	Filament Designation	Light Center Length (in.)	Max. Overall Length (in.)	Rated Average Lab Life (Hours)	Fig. No.
	Blister Pack	Unit Pack	Bulk Pack													
S-8 BULB 1" (25mm) DIAMETER (continued)																
1	12296	44760	18620	2057	Auto Stop, Signal		12.8	2.10A	32	D.C. Index	C	C-6	1.25	2.0	1,200	28
							14	.48A	2			C-6			5,000	
2	23339		10018	2057KR	Auto Stop, Signal. Krypton Fill. Long Life		12.8	2.10A	32	D.C. Index	C	C-6	1.25	2.0	2,400	28
							14.0	.48A	2			C-6			10,000	
3	12312	44763	44764	2057NA	Auto Stop, Signal - Natural Amber		12.8	2.10A	24	D.C. Index	C	C-6	1.25	2.0	1,200	28
							14.0	.48A	1.5			C-6			5,000	
4	47799			2057NAKR*	Auto Stop, Signal - Natural Amber. Krypton Fill. Long Life		12.8	2.10A	24	D.C. Index	C	C-6	1.25	2.0	2,400	28
							14.0	.48A	1.5			C-6			10,000	
5			12899	2058U	Auto/Truck Stop, Signal		12.8	2.10A	32	Wire Terminals ⁽¹¹³⁾	C	C-6	-	1.81	1,200	-
							14.0	.48A	2			C-6			5,000	
6			28085	2144	Auto/Truck		12.8	2.10A	32	Wire Terminals ⁽¹¹³⁾	C	C-6	-	1.75	1,200	-
7	12305	18389		3057	Auto Stop, Signal		12.8	2.10A	32	Plastic Wedge	C	C-6	1.10	2.09	1,200	29
							14.0	.48A	2			C-6			5,000	
8	26378			3057KR	Auto Stop, Signal. Krypton Fill. Long Life		12.8	2.10A	32	Plastic Wedge	C	C-6	1.1	2.09	2,000	29
							14.0	.48A	2			C-6			10,000	
9	12313	18391		3057NA	Auto Stop, Signal - Natural Amber		12.8	2.10A	24	Plastic Wedge	C	C-6	1.10	2.09	1,200	29
							14.0	.48A	1.5			C-6			5,000	
10	12351	21863		3156	Auto Stop		12.8	2.10A	32	Plastic Wedge	C	C-6	1.10	2.09	1,200	30
11	27565			3156KR*	Auto Stop. Krypton Fill. Long Life		12.8	2.10A	32	Plastic Wedge	C	C-6	1.10	2.09	2,000	30
12	12306	17172		3157	Auto Stop, Signal		12.8	2.10A	32	Plastic Wedge	C	C-6	1.10	2.09	1,200	29
							14.0	.59A	3			C-6			5,000	
13	26377			3157KR	Auto Stop, Signal. Krypton Fill. Long Life		12.8	2.10A	32	Plastic Wedge	C	C-6	1.10	2.09	2,000	29
							14.0	.59A	3			C-6			10,000	
14	12314	17173		3157NA	Auto Stop, Signal - Natural Amber		12.8	2.10A	24	Plastic Wedge	C	C-6	1.10	2.09	1,200	29
							14.0	.59A	2.2			C-6			5,000	
15	26380			3157NAKR	Auto Stop, Signal - Natural Amber. Krypton Fill. Long Life		12.8	2.10A	24	Plastic Wedge	C	C-6	1.10	2.09	2,000	29
							14.0	.59A	2.2			C-6			10,000	
16	12298	16291	16290	2357	Auto Stop, Signal		12.8	2.20A	40	D.C. Index	C	C-6	1.25	2.0	400	28
							14.0	.59A	3			C-6			5,000	
17	12299	15698	15699	2357NA	Auto/Truck Stop/Signal, Natural Amber		12.8	2.20A	30	D.C. Index	C	C-6	1.25	2.0	400	28
							14.0	.59A	2.2			C-6			5,000	
18		18047		2396	Auto Stop		12.8	2.23A	40	S.C. Bayonet	C	C-6	1.25	2.0	400	24
19	27560			2397*	Auto Stop, Signal		12.8	2.23A	40	D.C. Index	C	C-6	1.25	2.0	400	28
							14.0	.48A	2			C-6			5,000	

113. This is a flange seal wire terminal lamp. When unbased lamps such as these are handled and wired into a device, damage can be kept to a minimum by allowing sufficient clearance so that no physical strain or excessive heat is placed on the exhaust tube, exhaust tube tip, or glass

seal; by taking care in mounting lamp in equipment so that any material touching the glass is compatible in thermal expansion; and by avoiding excessive tensile strain on the lead wires.

MINIATURE LAMP SPECIFICATION

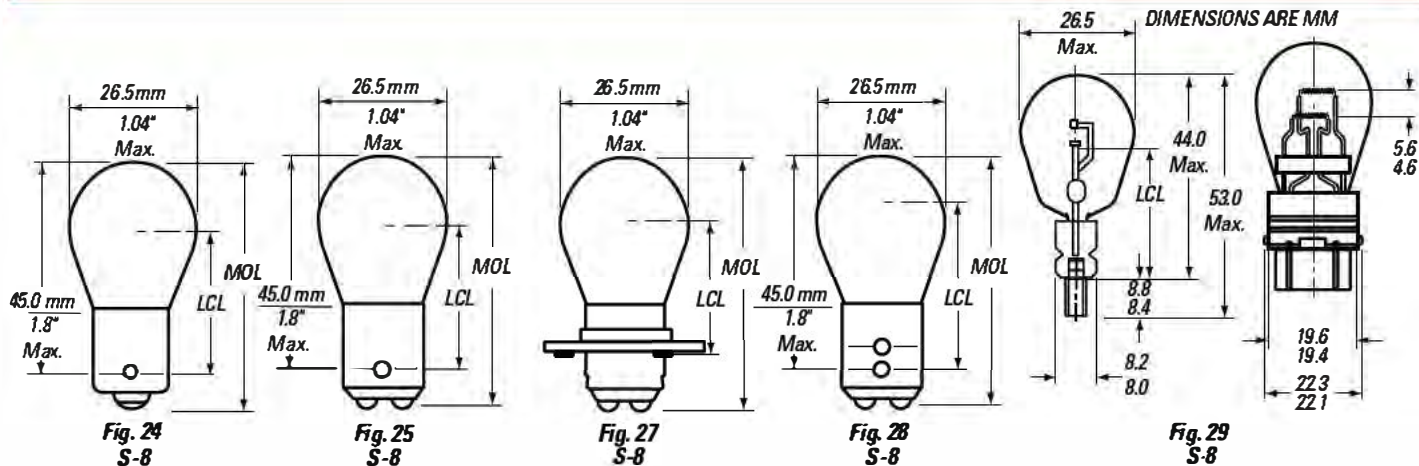

Line No.	Order Code			GE Lamp No.	Primary Application	Safety Notes	Design Volts	Design Watts or Amps	Mean Spherical CP (Approx.)	Base	Atmosphere B-Vac./C-Gas	Filament Designation	Light Center Length (in.)	Max. Overall Length (in.)	Rated Average Lab Life (Hours)	Fig. No.
	Blister Pack	Unit Pack	Bulk Pack													
S-8 BULB 1" (25mm) DIAMETER (continued)																
1	14387	22525		3357/3457	Auto Stop, Signal		12.8	2.23A	40	Plastic Wedge	C	C-6	1.10	2.09	400	29
2	26379			3357KR/3457KR	Auto Stop, Signal. Krypton		14.0	.59A	3	Plastic Wedge	C	C-6	1.10	2.09	5,000	29
					Fill. Long Life		12.8	2.23A	40	Plastic Wedge	C	C-6	1.10	2.09	800	
3	14388	22526		3357NA/3457NA	Auto Stop, Signal –		12.8	2.23A	30	Plastic Wedge	C	C-6	1.10	2.09	400	29
					Natural Amber		14.0	.59A	2.2	Plastic Wedge	C	C-6	1.10	2.09	5,000	
5	15657			4157KR*	Auto Stop, Signal. Krypton		12.8	2.23A	32	Plastic Wedge	C	C-6	1.10	2.09	3,600	29
					Fill. Long Life		14.0	.59A	3	Plastic Wedge	C	C-6	1.10	2.09	10,000	
6	47458			4157NAKR*	Auto Stop, Signal – Natural		12.8	2.23A	24	Plastic Wedge	C	C-6	1.10	2.09	3,600	29
					Amber. Krypton Fill. Long Life		14.0	.59A	2.2	Plastic Wedge	C	C-6	1.10	2.09	10,000	
7	37983	37984		198	Truck Stop, Signal –		12.8	2.25A ⁽¹⁴⁷⁾	32	D.C. Index	C	C-6	1.25	2.0	1,200	28
					Heavy Duty ⁽¹¹⁰⁾		14.0	.59A	3						5,000	
8	37985	37986		199	Truck Signal – Heavy Duty ⁽¹¹⁰⁾		12.8	2.25A	32	S.C. Bayonet	C	C-6	1.25	2.0	1,200	24
9	27561			P21/4W*	Auto Stop, Signal –		13.5	1.85A	35	D.C. Index	C	C-6	1.25	2.0	100	28
					European (ECE)		13.5	.37A	1.19	D.C. Index	C	C-6	1.25	2.0	100	
10	23303			P21/5W (P25-2)	Auto Stop, Signal –		13.5	1.85A	35	D.C. Index	C	C-6	1.25	2.0	250	28
					European (ECE)		13.5	.44A	2.78	D.C. Index	C	C-6	1.25	2.0	1,000	
11				P21/5W LL*	Auto Stop, Signal –		13.5	1.85A	35	D.C. Index	C	C-6	1.25	2.0	600	28
					European (ECE) – Long Life		13.5	.44A	2.78	D.C. Index	C	C-6	1.25	2.0	3,000	
12	23306	11601		P21W (P25-1)	Auto Stop – European (ECE)		13.5	1.85A	36.6	S.C. Bayonet	C	C-6	1.25	2.0	250	24
13		38655		P21WLL*	Auto Stop – European (ECE) –		13.5	1.85A	36.6	S.C. Bayonet	C	C-6	1.25	2.0	300	24
					Long Life											
14	41370	32648		PY21W*	Auto Stop – European (ECE) –		13.5	1.85A	22.3	S.C. Bayonet	C	C-6	1.25	2.0	250	24
					Amber Bulb											
15	27496			1634	Instrument, Microscope.		20.0	1.00A	24	D.C. Pf. (A)	C	CC-6	1.25	2.0	200	27
					Illuminator – Bun base up to horiz											
16	26143			305	Aircraft		28.0	.51A	15	S.C. Bayonet	C	C-2V ⁽¹³⁾	1.12	2.0	300	24
17	26145			305AF	Aircraft – All frosted		28.0	.51A	–	S.C. Bayonet	C	C-2V ⁽¹³⁾	–	2.0	300	24
18	26152			306	Aircraft		28.0	.51A	15	D.C. Bayonet	C	C-2V ⁽¹³⁾	1.12	2.0	300	25
19	43132			705	Aircraft		28.0	.51A	15	S.C. Bayonet	C	CC-6	1.12	2.0	900	24
20	40943			1591	Auto		28.0	.61A	15	S.C. Bayonet	C	C-2V ⁽¹³⁾	1.12	2.0	1,000	24
21	40945			1591AF	Aircraft – All frosted		28.0	.61A	–	S.C. Bayonet	C	C-2V ⁽¹³⁾	–	2.0	1,000	24
22	27566			1691	Aircraft – 2 identical		28.0	.61A	15	S.C. Bayonet	C	2C-2R	1.12	2.0	1,000	24
					filaments in series											
23	27568			1691AF	Aircraft – All frosted – 2		28.0	.61A	–	S.C. Bayonet	C	2C-2R	–	2.0	1,000	24
					identical filaments in series											

13. Supported.

147. Differs from ANSI.

110. To be used with variable load flasher in applications where bulb outage indication is not required, or with an appropriate fixed load flasher. Flash rate may be altered if used with incorrect fixed load flasher.

MINIATURE LAMP SPECIFICATION

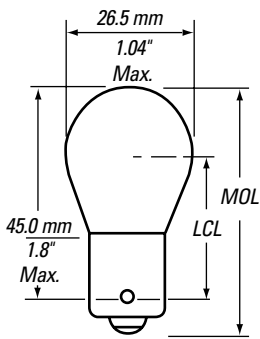

Fig. 24
S-8

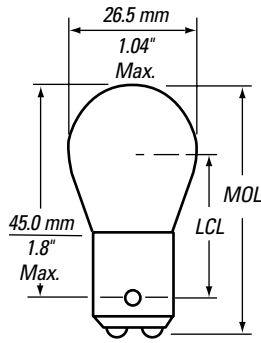

Fig. 25
S-8

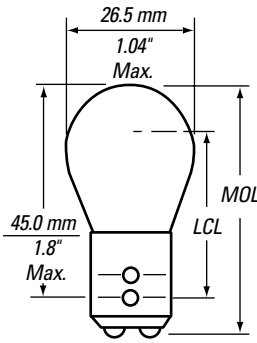

Fig. 28
S-8

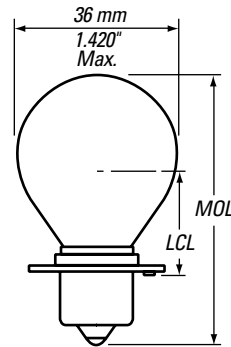

Fig. 31
S-11

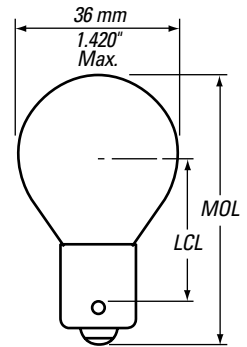

Fig. 32
S-11

Line No.	Order Code			GE Lamp No.	Primary Application	Safety Notes	Design Volts	Design Watts or Amps	Mean Spherical CP (Approx.)	Base	Atmosphere B-Vac./C-Gas	Filament Designation	Light Center Length (in.)	Max. Overall Length (in.)	Rated Average Lab Life (Hours)	Fig. No.
	Blister Pack	Unit Pack	Bulk Pack													
S-8 BULB 1" (25mm) DIAMETER (continued)																
1		27571		1692	Marine – 2 identical filaments in series		28.0	.61A	15	D.C. Bayonet	C	2C-2R	1.12	2.0	1,000	25
2		34763		2232	Aircraft – Spiral lead		28.0	.643A	18	S.C. Bayonet	C	CC-8	1.19	2.0	2,000	24
3		26702		2232LL*	Aircraft – Spiral lead. Long Life		28.0	.643A	18	S.C. Bayonet	C	CC-8	1.19	2.0	4,000	24
4		43134		2232SB	Aircraft – Spiral lead Top of bulb reflectorized		28.0	.643A	–	S.C. Bayonet	C	CC-8	1.19	2.0	2,000	24
5		26157		307	Aircraft		28.0	.67A	21	S.C. Bayonet	C	C-2V ⁽¹³⁾	1.12	2.0	300	24
6		26161		307AF	Aircraft – All frosted		28.0	.67A	21	S.C. Bayonet	C	C-2V ⁽¹³⁾	–	2.0	300	24
7		26168		308	Aircraft		28.0	.67A	21	D.C. Bayonet	C	C-2V ⁽¹³⁾	1.12	2.0	300	25
8		26171		308AF	Aircraft – All frosted		28.0	.67A	–	D.C. Bayonet	C	C-2V ⁽¹³⁾	–	2.0	300	25
9		27032		1203	Special Service		28.0	.71A	21	S.C. Bayonet	C	C-2V ⁽¹³⁾	1.25	2.0	400	24
10		36906		2233	Aircraft – Spiral lead		28.0	.766A	21	S.C. Bayonet	C	CC-8	1.19	2.0	2,000	24
11		27532		1665	Aircraft		28.0	.80A	21	S.C. Bayonet	C	C-2V ⁽¹³⁾	1.12	2.0	1,000	24
12		27533		1665AF	Aircraft – All frosted		28.0	.80A	–	S.C. Bayonet	C	C-2V ⁽¹³⁾	–	2.0	1,000	24
13		26238		315	Aircraft		28.0	.90A	32	S.C. Bayonet	C	C-2V ⁽¹³⁾	1.12	2.0	300	24
14		27529	27530	1662	Aircraft – C-2V Filament inverted ^(15,33)		28.0	.93A	32	D.C. Index	C	CC-6 ⁽¹³⁾	1.25	2.0	400	28
15			32701	2155	Truck ⁽¹⁵⁾		28.0	.34A	6			C-2V			1,000	
15							28.0	.93A	32	Wire Terminals		CC-6 ⁽¹³⁾	–	1.75	400	–
15							28.0	.34A	6			C-2V			1,000	
16			30856	P21/5W*	Bus Stop /Tail-European (ECE)		28.0	1.00A	35	D.C. Index	C	C-6	1.25	2.0	150	28
16							28.0	.36A	3.18			C-6			1,500	
17		40778		P21W 24V*	Bus Stop-European (ECE)		28.0	1.00A	36.6	S.C. Bayonet	C	C-6	1.25	2.0	150	24
18		27504		1638	Marine – 2 identical filaments in series		28.0	1.02A	32	D.C. Bayonet	C	2C-6	1.25	2.0	500	25
19		27557		1683	Aircraft – 2 identical filaments in series		28.0	1.02A	32	S.C. Bayonet	C	2C-6	1.25	2.0	500	24
20		39904		1229	Special Service, Emergency Lighting		40.0	.38A	15	D.C. Bayonet	C	C-2V ⁽¹³⁾	1.12	2.0	400	25
S-11 BULB 1 1/8" (35mm) DIAMETER																
21		27431		1561	Instrument, Colorimeter		6.3	4.00A	24	S.C. Pf. (B)	C	C-8Z	.88	2.38	1,500	31
22		26175		309	Aircraft		28.0	.90A	32	S.C. Bayonet	C	C-2V ⁽¹³⁾	1.25	2.38	300	32
23		26191		311	Aircraft		28.0	1.29A	50	S.C. Bayonet	C	C-2V ⁽¹³⁾	1.25	2.38	300	32
24		36508		3011	Aircraft		28.0	1.29A	44	S.C. Bayonet	C	C-2V ⁽¹³⁾	1.25	2.38	1,000	32

13. Supported.

15. This lamp is specially designed for a particular purchaser and may not be suitable for other uses because of its limited mechanical strength.

33. Connections of major and minor filament to base are reversed from those for automotive lamps with Double Contact Index bases. Burn base down to horizontal.

MINIATURE LAMP SPECIFICATION

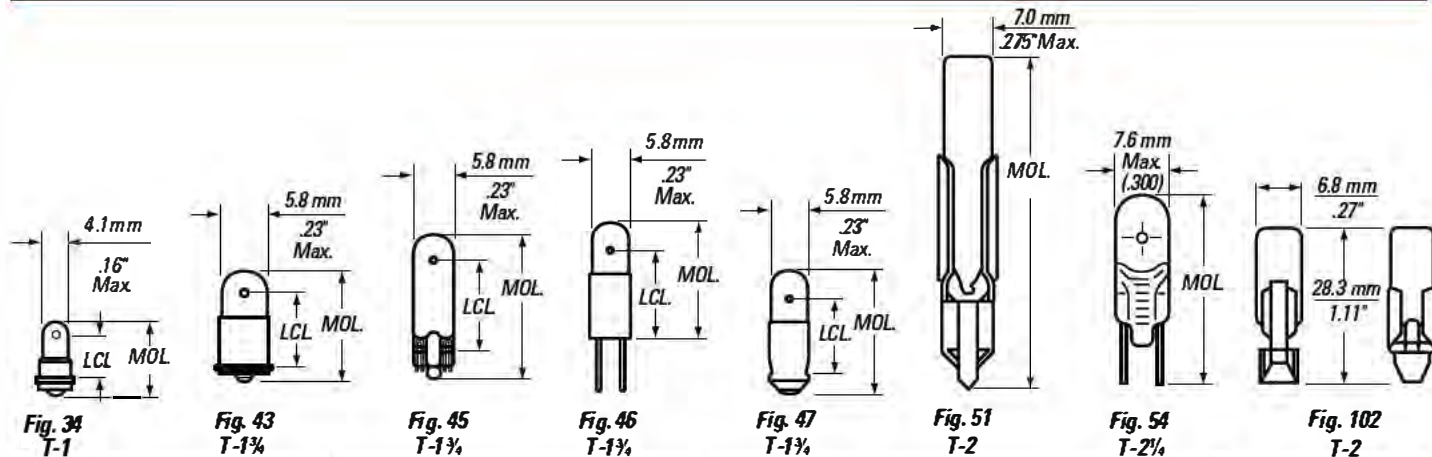

Line No.	Order Code			GE Lamp No.	Primary Application	Safety Notes	Design Volts	Design Watts or Amps	Mean Spherical CP (Approx.)	Base	Atmosphere B-Vac./C-Gas	Filament Designation	Light Center Length (in.)	Max. Overall Length (in.)	Rated Average Life (Hours)	Fig. No.
	Blister Pack	Unit Pack	Bulk Pack													
T-1 BULB ¼" (3mm) DIAMETER																
1			28706	685	Aircraft		5.0	.06A	.05	Sub-Midget Flanged	B	C-2R	.19	.38	40,000 ⁽⁷⁹⁾	34
T-1½ BULB 7/32" (5.5mm) DIAMETER																
2		28546		328	Aircraft		6.0	.20A	.34 ⁽⁸⁰⁾	S.C. Midget Flanged	B	C-2R	.38	.63	1,000	43
3		40967	40968	86	Indicator		6.3	.20A	.4	Wedge ⁽¹²⁴⁾	B	C-2F	.40	.80	20,000 ⁽⁷⁹⁾	45
4		28653		381	Indicator		6.3	.20A	.4	S.C. Midget Flanged	B	C-2F	.38	.63	20,000 ⁽⁷⁹⁾	43
5	23015	39218	39219	73	Indicator		14.0	.08A	.3	Wedge	B	C-2F	.40	.80	15,000 ⁽⁷⁹⁾	45
6		28567		330	Aircraft		14.0	.08A	.5	S.C. Midget Flanged	B	C-2F	.38	.63	1,500	43
7		28657		382	Indicator		14.0	.08A	.3	S.C. Midget Flanged	B	C-2F	.38	.63	40,000 ⁽⁷⁹⁾	43
8		28662		386	Indicator		14.0	.08A	.3	Midget Grooved	B	C-2F	.38	.63	40,000 ⁽⁷⁹⁾	47
9	26480	39220	13689	37	Auto		14.0	.09A	.5	Wedge	B	C-2F	.40	.80	2,500	45
10	21029	38457	38458	74	Auto		14.0	.10A	.7	Wedge	B	C-2F	.40	.80	1,000	45
11		43606	43607	70	Auto ⁽¹⁴⁾		14.0	.15A	1.5	Wedge	B	C-2F	.40	.80	100	45
12		40969		85	Indicator		28.0	.04A	.3	Wedge	B	C-2F	.40	.80	7,000 ⁽⁷⁹⁾	45
13		28519		327	Aircraft		28.0	.04A	.34	S.C. Midget Flanged	B	C-2F	.38	.63	4,000 ⁽⁷⁹⁾	43
14		28588		334	Aircraft		28.0	.04A	.34	Midget Grooved	B	C-2F	.38	.63	4,000 ⁽⁷⁹⁾	47
15		28660		385	Indicator ⁽⁷⁸⁾		28.0	.04A	.15	S.C. Midget Flanged	B	C-2F	.44	.81	10,000 ⁽⁷⁹⁾	43
16		28664		387	Indicator		28.0	.04A	.3	S.C. Midget Flanged	B	C-2F	.38	.63	7,000 ⁽⁷⁹⁾	43
17		28672		388	Indicator		28.0	.04A	.3	Midget Grooved	B	C-2F	.38	.63	7,000 ⁽⁷⁹⁾	47
18		28926		7387	Indicator		28.0	.04A	.3	Bi-Pin M-23	B	C-2F	.50	.61	7,000 ⁽⁷⁹⁾	46
T-2 BULB ¼" (6.8mm) DIAMETER																
19		12756		6PSB	Indicator		6.0	.14A	550 ⁽⁸⁰⁾	Tel. Slide #5	B	C-2V		1.11	20,000	102
20		12760		12PSB	Indicator		12.0	.17A	2,000 ⁽⁸⁰⁾	Tel. Slide #5	B	C-2F		1.11	12,000	102
21		29001		24E2	Telephone		24.0	.035A	600 ⁽⁸⁰⁾	Tel. Slide #3	B	C-2F		1.69	7,000	51
22		12071		24PSB	Indicator		24.0	.073A	3,000 ⁽⁸⁰⁾	Tel. Slide #5	B	C-2F		1.11	10,000	102
23		12072		28PSB	Indicator		28.0	.04A	1,600 ⁽⁸⁰⁾	Tel. Slide #5	B	C-2F		1.11	5,000	102
24		29041		48C2	Telephone		48.0	.035A	750 ⁽⁸⁰⁾	Tel. Slide #3	B	C-2F		1.69	5,000	51
25		12075		48PSB	Indicator		48.0	.05A	1,800 ⁽⁸⁰⁾	Tel. Slide #5	B	C-7A		1.11	10,000	102
26		12077		60PSB	Indicator		60.0	.05A	1,800 ⁽⁸⁰⁾	Tel. Slide #5	B	C-7A		1.11	7,500	102
27		12080		120PSB	Indicator		120.0	.025A	1,000 ⁽⁸⁰⁾	Tel. Slide #5	B	CC-7A		1.11	7,500	102
T-2½ BULB 7/32" (7.5mm) DIAMETER																
28		47618		777	Flashlight, Halogen	306	4.0	1.20A	5.5	G-4 Two Pin ⁽¹²⁴⁾	C	C-6	.77	1.0	275	54
29		43760	43761	784	Emergency Lighting - Halogen	306	6.0	1.00A	9	G-4 Two Pin ⁽¹²⁴⁾	C	C-6	.77	1.0	50	54
30		43762	43763	785	Emergency Lighting - Halogen	306	6.0	1.33A	13	G-4 Two Pin ⁽¹²⁴⁾	C	C-6	.77	1.0	50	54
31		43115	43116	787	Instrument - Halogen	306	6.0	1.67A	16	G-4 Two Pin ⁽¹²⁴⁾	C	C-6	.77	1.0	100	54

10. At 5 volts.

14. This lamp is specially designed for a particular purchaser and may not be suitable for other uses because of its excessive wattage requirements for the bulb size.

78. ANSI specifies .38" light center length and .63" maximum overall length.

79. Life shown is AC voltage only. DC life will be approx. 50% of AC.

80. Design end foot candles, not spherical CP.

124. .028" metal pins spaced 44mm (.157") apart. GE's all-glass two-pin lamps might not be compatible with all G-4 sockets since many sockets do not provide clearance for the exhaust tip.

130. Subminiature wedge base lamps under 12 volts have copper-clad outer lead wires to decrease contact resistance at the expense of corrosion resistance in severe environments.

306. See page 50.

MINIATURE LAMP SPECIFICATION

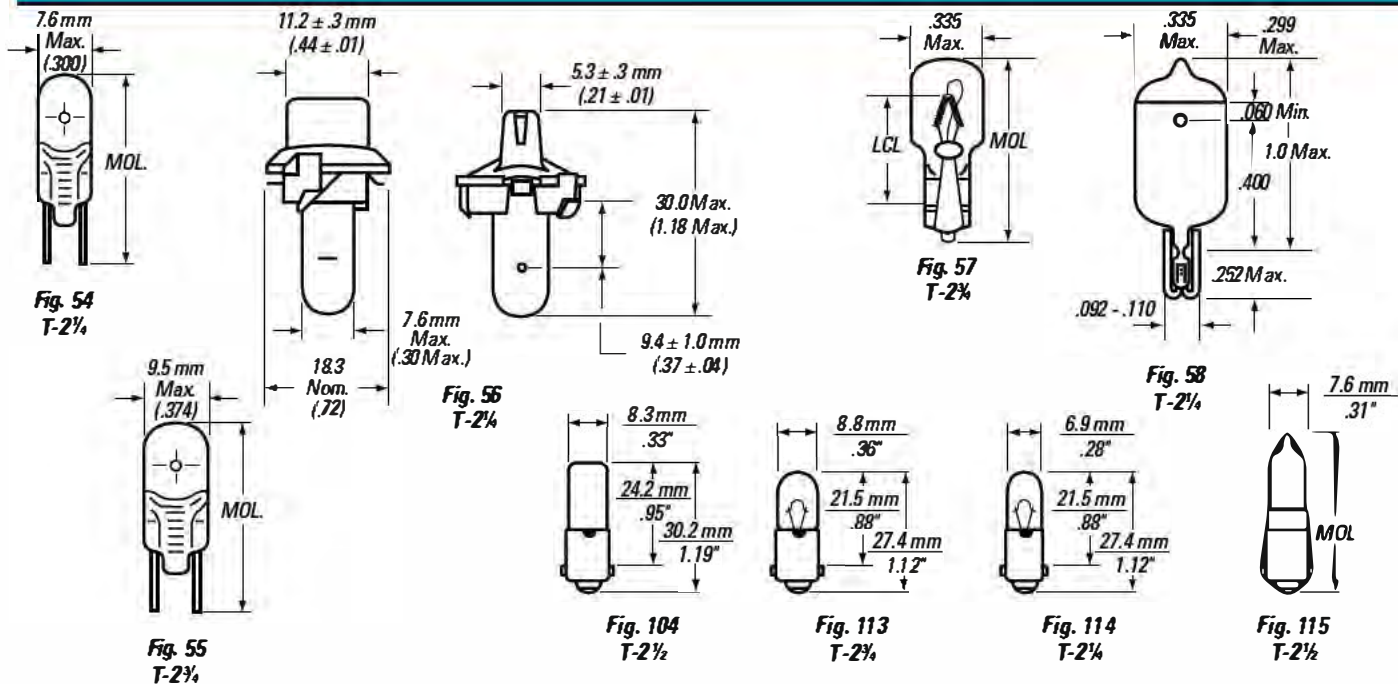

Line No.	Order Code			GE Lamp No.	Primary Application	Safety Notes	Design Volts	Design Watts or Amps	Mean Spherical CP (Approx.)	Base	Atmosphere B-Vac./C-Gas	Filament Designation	Light Center Length (in.)	Max. Overall Length (in.)	Rated Average Lab Life (Hours)	Fig. No.
	Blister Pack	Unit Pack	Bulk Pack													
T-2½ BULB 7/32" (7.5mm) DIAMETER (continued)																
1		11014		767	Instrument - Halogen	306	6.0	2.00A	19	Miniature Bayonet	C	C-6	.56	1.13	50	114
2		43764	43765	786	Emergency Lighting - Halogen	306	6.0	2.00A	19	G-4 Two Pin ⁽¹²⁴⁾	C	C-6	.77	1.0	50	54
3		43117	43118	788	Instrument - Halogen	306	6.0	3.33A	32	G-4 Two Pin ⁽¹²⁴⁾	C	C-6	.77	1.0	100	54
4		12723	12724	774	Emergency Lighting - Halogen	306	12.0	.67A	13	G-4 Two Pin ⁽¹²⁴⁾	C	C-6	.77	1.0	50	54
5		44500	44501	783	Emergency Lighting - Halogen	306	12.0	1.00A	22	G-4 Two Pin ⁽¹²⁴⁾	C	C-6	.77	1.0	50	54
6		13158	13161	882	Auto Inst. - Halogen	306	12.8	.35A	3.8	Printed Circuit Socket	C	C-6	.37	1.18	2,000	56
7		18167	16772	882X	Auto Inst. - Halogen	306	12.8	.35A	3.8	G-4 Two Pin ⁽¹²⁴⁾	C	C-6	.77	1.0	2,000	54
8	12326	19280		2040	Auto Light Bar	306	12.8	.625A	10.5	Wedge	C	C-6	.40	1.25	500	58
9	12308	15246	15248	891	Auto High Mounted Stop, Halogen	306	12.8	.63A	11	G-4 Two Pin ⁽¹²⁴⁾	C	C-6	.77	1.0	500	54
T-2½ BULB 5/16" (8.3mm) DIAMETER																
10		26697		2059*	Aircraft-Reading Lamps - Long Life	304	12.0	.833A	9.1	Miniature Bayonet	C	C-8	0.59	1.30	4,000	115
11		26698		2059X*	Aircraft-Reading Lamps - Long Life - Blacktopped	304	12.0	.833A	8	Miniature Bayonet	C	C-8	0.59	1.30	4,000	115
12		12761		28MB	Indicator		28.0	.04A	.29	Miniature Bayonet	B	C-2F	-	1.19	5,000	104
13		12076		60MB	Indicator		60.0	.05A	.73	Miniature Bayonet	B	C-7A	-	1.19	7,500	104
14		12078		120MB	Indicator		120.0	.025A	.36	Miniature Bayonet	B	CC-7A	-	1.19	7,500	104
T-2½ BULB 7/32" (8.7mm) DIAMETER																
15		49718		778	Instrument - Halogen - High temp. fixtures	306	6.0	3.33A	32	G-4 Two Pin ⁽¹²⁴⁾	C	C-6	.77	1.05	100	55
16		11250		773	Special Service - Halogen	306	12.0	.67A	10	G-4 Two Pin ⁽¹²⁴⁾	C	C-6	.77	1.05	1,000	55
17		18344		780	Strip Light - Halogen	306	12.0	10W	12	G-4 Two Pin ⁽¹²⁴⁾	C	C-6	.77	1.05	2,000	55
18		43119		789	Instrument - Halogen	306	12.0	1.17A	22	G-4 Two Pin ⁽¹²⁴⁾	C	C-6	.77	1.05	200	55
19		44840	44841	782	Special Service - Halogen	306	12.0	1.66A	25	G-4 Two Pin ⁽¹²⁴⁾	C	C-6	.77	1.05	2,000	55
20	23318			T4W	Auto. ECE T4W GE 2662		13.5	.30A	2.8	Miniature Bayonet	B	C-2R	.59	1.08	450	113
21	12325	17853		24	Auto Side Marker		14.0	24A	2	Wedge	B	C-2V	.46	.91	1,500	57
22	12316			24NA	Auto Side Marker		14.0	24A	1.5	Wedge	B	C-2V	.46	.91	1,500	57
23		43121	43122	790	Instrument - Halogen	306	14.0	1.79A	42	G-4 Two Pin ⁽¹²⁴⁾	C	C-6	.77	1.05	200	55
24		43123	43124	791	Instrument - Halogen	306	14.0	2.50A	61	G-4 Two Pin ⁽¹²⁴⁾	C	C-6	.77	1.05	200	55

124. .028" metal pins spaced 44mm (.157') apart. GE's all-glass two-pin lamps might not be compatible with all G-4 sockets since many sockets do not provide clearance for the exhaust tip.

304. See page 50.

306. See page 50.

MINIATURE LAMP SPECIFICATION

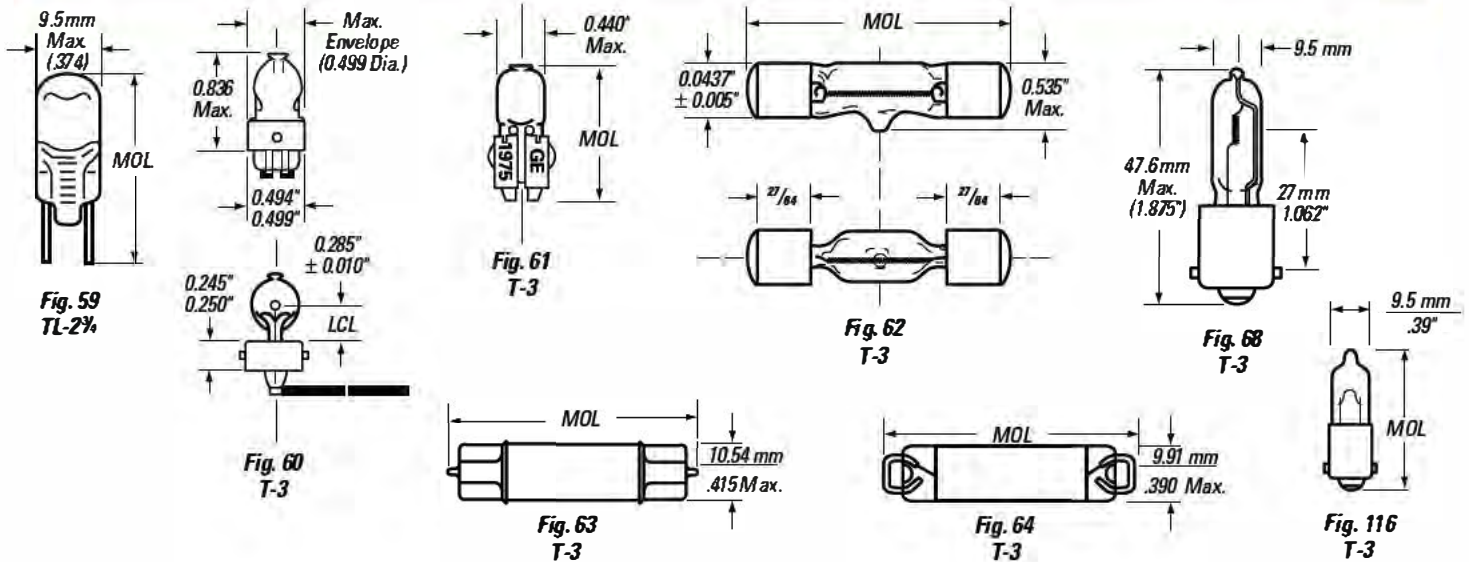

Line No.	Order Code			GE Lamp No.	Primary Application	Safety Notes	Design Volts	Design Watts or Amps	Mean Spherical CP (Approx.)	Base	Atmosphere B-Vac./C-Gas	Filament Designation	Light Center Length (in.)	Max. Overall Length (in.)	Rated Average Lab Life (Hours)	Fig. No.
	Blister Pack	Unit Pack	Bulk Pack													
TL-2 1/2 BULB 3/32" (87mm) DIAMETER																
1		43805		2604X	Instrument—Lens end ¹²⁸	306	5.0	2.00A	(128)	G-4 Two Pin ¹²⁴	C	C-6	—	1.18	5,000	59
T-3 BULB 3/8" (9.5mm) DIAMETER																
2		32780		1974	Instrument—Quartz Bulb—3" base leads horizontal	304	6.0	20W	10	Wire Terminals	C	C-6	.285	1.14	10,000	60
3		21494		2074	Instrument—Quartz Bulb	304	7.0	25W	24	Wire Terminals	C	C-6	.285	1.14	2,700	60
4		39641		1962B	Special Service—Quartz Bulb—9" leads horizontal	304	8.5	62W	110	Wire Terminal	C	C-6	.285	1.14	50	60
5			12859	1962BG	Aircraft—Quartz Bulb—Halogen	304	8.5	62W	110	Wire Terminals	C	C-6	.285	1.14	50	—
6			37947	1962DX	Special Service—Quartz Bulb—4" bare leads down	304	8.5	62W	80	Wire Terminals	C	C-6	.285	1.14	150	60
7		44152		1962DZ	Special Service—Quartz Bulb—12" insulated leads down	304	8.5	62W	80	Wire Terminals	C	C-6	.285	1.14	150	60
8		13667		1962TY	Medical—Quartz Bulb—7 3/4" Leads Horizontal	304	8.5	62W	110	Wire Terminals	C	C-6	.285	1.14	50	60
9		38545		1978X	Aircraft Navigation—Quartz Bulb	304	10.0	100W	130	Special	C	C-8	—	2.15	2,000	62
10		38535		1988	Aircraft Gunsight—Quartz Bulb	304	10.0	100W	130	Special Wire Leads	C	C-8	—	2.15	2,000	—
11		14689		3078*	Aircraft Navigation—Quartz Bulb—Long Life	304	10.0	100W	95	Special	C	C-8	—	2.15	4,500	62
12	12673	39224	11803	211-2	Auto		12.8	.97A	12	Miniature Cap	C	C-8	—	1.72	1,000	63
13	12358	39746	11820	561	Auto		12.8	.97A	12	Rigid Loop	C	C-8	—	1.72	1,000	64
14	45591			56110*	Auto-Interior-12V 20W	308	13.2	1.83A	40	Miniature Bayonet	C	C-2R	.59	1.22	100	116
15	47461			58540*	Auto-Interior-12V 5W	308	13.5	.37A	63	Miniature Bayonet	C	C-2R	.59	1.22	240	116
16	40135	39356	11804	214-2	Auto		13.5	.92A	4	Miniature Cap	C	C-8	—	1.72	1,000 ⁽⁴⁾	63
17	26205		11825	563	Auto		13.5	.92A	4	Rigid Loop	C	C-8	—	1.72	1,000 ⁽⁴⁾	64
18	23220		11806	212-2	Auto		13.5	.74A	6	Miniature Cap	C	C-8	—	1.72	2,000 ⁽⁴⁾	63
19	23019		11822	562	Auto		13.5	.74A	6	Rigid Loop	C	C-8	—	1.72	2,000 ⁽⁴⁾	64
20		28034		1968	Aircraft Gunsight—Quartz Bulb	304	28.0	25W	15	Double Slide	C	C-2V ⁽¹³⁾	.41	1.17	500	61
21		26696		A-103*	Aircraft-Quartz Bulb-Navigation	304	28.0	50W	60	Special	C	CC-8	—	1.87	1,000	62
22		38627		1982	Aircraft Navigation—Quartz Bulb	304	28.0	75W	110	S.C. Bayonet	C	CC-8 ⁽¹³⁾	1.06	1.88	1,000	68
23		21061		1982SP	Aircraft—Quartz Bulb	304	28.0	75W	107	S.C. Bayonet	C	CC-6	1.00	1.97	2,000	68

4. At 14 volts.

13. Supported.

124. .028" metal pins spaced 44mm (.157") apart. GE's all-glass two-pin lamps might not be compatible with all G-4 sockets since many sockets do not provide clearance for the exhaust tip.

128. Minimum 1/4" spot at .100" from bulb top

304. See page 50.

306. See page 50.

308. See page 50.

MINIATURE LAMP SPECIFICATION

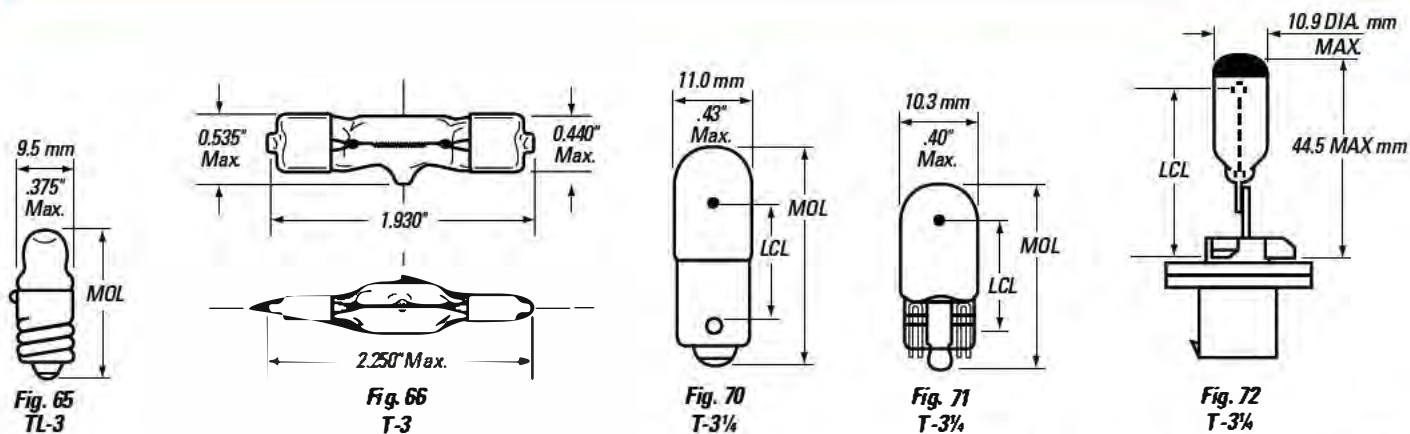

Line No.	Order Code			GE Lamp No.	Primary Application	Safety Notes	Design Volts	Design Watts or Amps	Mean Spherical CP (Approx.)	Base	Atmosphere B-Vac./C-Gas	Filament Designation	Light Center Length (in.)	Max. Overall Length (in.)	Rated Average Lab Life (Hours)	Fig. No.
	Blister Pack	Unit Pack	Bulk Pack													
T-3 BULB 3/4" (9.5mm) DIAMETER (continued)																
1		28036		1970	Aircraft – Quartz Bulb	304	28.0	100W	150	Special Sleeve	C	CC-8	–	2.25	1,000	66
2		41938		1970X	Aircraft – Quartz Bulb	304	28.0	100W	140	Special Sleeve	C	CC-8 ⁽¹¹³⁾	–	2.25	1,000	66
3			19792	2556	Aircraft – Quartz Bulb	304	28.0	200W	25	Two Pin	C	CC-6	.87	1.46	50	–
4		18617		1946	Aircraft – Quartz Bulb – Halogen	304	28.0	250W	660	Two Pin with Leads	C	CC-6	.87	1.46	50	–
TL-3 BULB 3/4" (9.5mm) DIAMETER																
5		25848		112	Flashlight – 1AA, C or D cell		1.2	.22A	–	Miniature Screw	B	S-2	–	.93	5 ⁽¹¹⁶⁾	65
6		26008		222	Flashlight – AA cells		2.25	.25A	–	Miniature Screw	B	C-2R	–	.93	5 ⁽¹¹⁶⁾	65
7		26063		243	Flashlight – 2 C cells		2.33	.27A	–	Miniature Screw	B	C-2R	–	.93	10 ⁽¹¹⁶⁾	65
T-3 1/2 BULB 1/2" (10mm) DIAMETER																
8		25442		43	Indicator		2.5	.50A	.5	Miniature Bayonet	B	C-2R	.78	1.19	3,000	70
9		27833		1850	Signal – Plane of filament perpendicular to base pins		5.0	.09A	.25	Miniature Bayonet	B	C-2R	.62	1.19	1,500 ⁽¹¹⁶⁾	70
10		26243		316	Aircraft		6.0	.70A	3.4	Miniature Bayonet	C	C-2R	.62	1.19	500	70
11			15731	149	Emergency Lighting		6.15	.53A	3.5	Wedge	B	C-2R	.56	1.06	15	71
12		25485		47	Radio, TV, and Indicator		6.3	.15A	.52	Miniature Bayonet	B	C-2R	.78	1.19	3,000	70
13		42758		267	Indicator – Flasher Lamp ⁽⁷⁰⁾		6.3	.15A	.33	Miniature Bayonet	B	C-2R	.62	1.19	5,000 ⁽¹¹⁷⁾	70
14		26591		755	Indicator		6.3	.15A	.33	Miniature Bayonet	B	C-2R	.78	1.19	20,000	70
15		27819		1847	Radio, TV, and Indicator		6.3	.15A	.38	Miniature Bayonet	B	C-2R	.78	1.19	5,000 ⁽⁴⁴⁾	70
16		25450		44	Indicator, Radio, and TV		6.3	.25A	.9	Miniature Bayonet	B	C-2R	.78	1.19	3,000	70
17		26099		259	Radio, TV, and Indicator		6.3	.25A	.65	Wedge	B	C-2R	.65 ⁽¹⁴⁷⁾	1.06	5,000 ⁽⁴⁴⁾	71
18		44773	44774	555	Coin, Novelty		6.3	.25A	.9	Wedge	B	C-2R	.65	1.06	3,000	71
19		27868		1866	Radio		6.3	.25A	.65	Miniature Bayonet	B	C-2R	.78	1.19	5,000 ⁽⁴⁴⁾	70
20		25916		147	Indicator		7.0	.43A	2	Wedge	B	C-2R	.56	1.06	1,500	71
21		27179		1408	Signal		10.0	.13A	.85	Miniature Bayonet	B	C-2V ⁽¹³⁾	.62	1.19	250	70
22		16481		892	Auto, Signal – Halogen	306	12.8	1.25A	28	Axial	C	C-6	1.00	2.68	300	72
23	12320		20904	880 (H27W/1)	Auto Fog. ECE type H27W/1 ⁽¹⁷⁾	306	12.8	2.10A	43 ⁽¹⁶⁰⁾	Axial Prefocus/ PG13	C	C-6	1.25	2.68	300	72
24			27582	880L*	Auto Fog. ECE type H27W/1-Long Life ⁽¹⁷⁾	306	12.8	2.10A	43 ⁽¹⁶⁰⁾	Axial Prefocus	C	C-6	1.25	2.68	300	72
25			14694	880X	Auto Fog. ECE type H27W/1-Sealed Base ⁽¹⁷⁾	306	12.8	2.10A	43 ⁽¹⁶⁰⁾	Axial Prefocus	C	C-6	1.25	2.68	1,000	72

3. Useful hours.

13. Supported.

17. Filament shielded.

44. At 6.6 volts.

70. These lamps produce a random flashing indication only. While the majority should flash between 40-160 flashes per minute at normal room temperature, some will be outside this range. As ambient temperature and/or input voltage

changes, the flash rate may vary considerably. At rated voltage and room temperature most lamps will flash within 60 seconds.

116. Life tests are performed on DC voltage only.

147. Differs from ANSI

160. Filament will generate specified mscp in a non shielded bulb.

304. See page 50.

306. See page 50.

MINIATURE LAMP SPECIFICATION

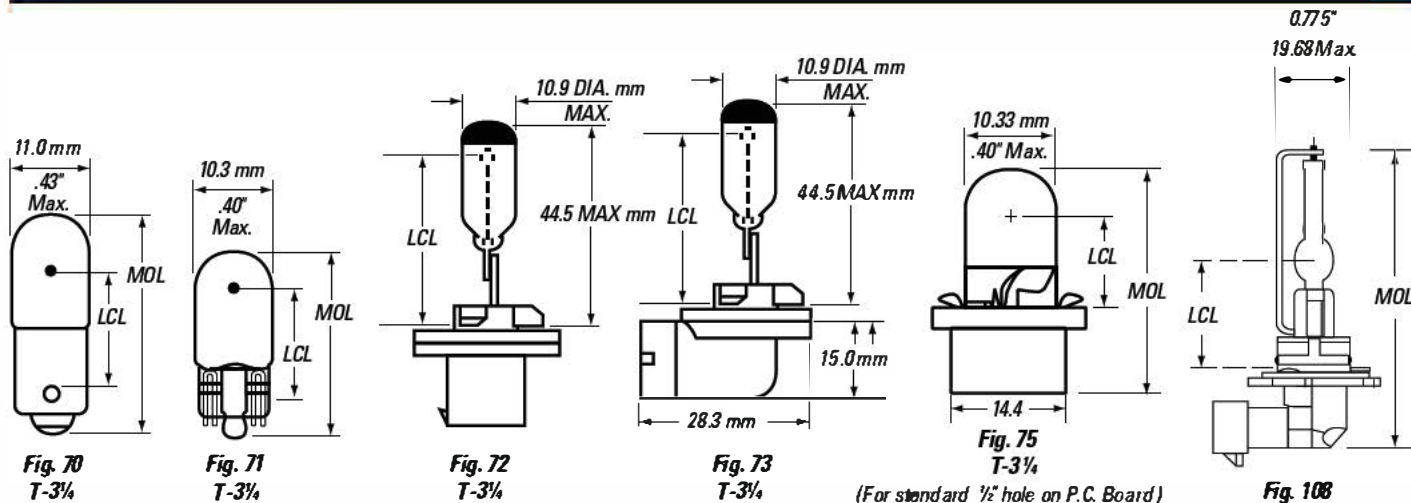

Line No.	Order Code			GE Lamp No.	Primary Application	Safety Notes	Design Volts	Design Watts or Amps	Mean Spherical CP (Approx.)	Base	Atmosphere B-Vac./C-Gas	Filament Designation	Light Center Length (in.)	Max. Overall Length (in.)	Rated Average Lab Life (Hours)	Fig. No.
	Blister Pack	Unit Pack	Bulk Pack													
T-3/4 BULB 13/32" (10mm) DIAMETER (continued)																
1	12334		20905	881 (H27W/2)	Auto Fog. ECE type H27W/2 ⁽¹⁷⁾	306	12.8	2.10A	43 ⁽¹⁰⁰⁾	Right Angle Prefocus / PGJ13	C	C-6	1.25	2.68	300	73
2			27583	881L*	Auto Fog. ECE type H27W/2-Long Life ⁽¹⁷⁾	306	12.8	2.10A	43 ⁽¹⁰⁰⁾	Right Angle Prefocus	C	C-6	1.25	2.68	1,000	73
3			11646	881X	Auto Fog. ECE type H27W/2-Sealed Base ⁽¹⁷⁾	306	12.8	2.10A	43 ⁽¹⁰⁰⁾	Right Angle Prefocus	C	C-6	1.25	2.68	300	73
4	12336		20910	889	Auto - Signal, Halogen	306	12.8	2.10A	43	Right Angle	C	C-6	1.00	2.68	300	73
5	12337		20911	890	Auto - Signal, Halogen	306	12.8	2.10A	43	Axial	C	C-6	1.00	2.68	300	72
6		40848	14132	862	Traction	306	12.8	2.93A	60	Right Angle Prefocus	C	C-6	1.25	2.68	1,900	73
7	12338		20913	893	Auto Fog ⁽¹⁷⁾	306	12.8	2.93A	75 ⁽¹⁰⁰⁾	Axial Prefocus	C	C-6	1.25	2.68	200 ⁽⁴⁾	72
8			12727	893X	Auto Fog ⁽¹⁷⁾	306	12.8	2.93A	75 ⁽¹⁰⁰⁾	Axial Prefocus	C	C-6	1.25	2.68	200 ⁽⁴⁾	72
9	22112	20238	18455	894	Traction	306	12.8	2.93A	75	Right Angle Prefocus	C	C-6	1.25	2.68	200 ⁽⁴⁾	73
10			26345	894X*	Traction-Sealed Base	306	12.8	2.93A	75	Right Angle Prefocus	C	C-6	1.25	2.68	200 ⁽⁴⁾	73
11	22113		20914	896	Auto Fog ⁽¹⁷⁾	306	12.8	2.93A	75 ⁽¹⁰⁰⁾	Right Angle Prefocus	C	C-6	1.25	2.68	200 ⁽⁴⁾	73
12			12271	898	Auto Fog ⁽¹⁷⁾	306	12.8	2.93A	60 ⁽¹⁰⁰⁾	Right Angle Prefocus	C	C-6	1.25	2.68	1,900 ⁽⁴⁾	73
13	22111		12272	899	Auto Fog ⁽¹⁷⁾	306	12.8	2.93A	60 ⁽¹⁰⁰⁾	Axial Prefocus	C	C-6	1.25	2.68	1,900 ⁽⁴⁾	72
14	12335		20907	885	Auto Fog	306	12.8	3.90A	100	Axial Prefocus	C	C-6	1.25	2.68	200 ⁽⁴⁾	72
15	14689		20909	886	Auto Fog	306	12.8	3.90A	100	Right Angle Prefocus	C	C-6	1.25	2.68	200 ⁽⁴⁾	73
16			25639	887	Traction Work Light	306	12.8	3.90A	95	Axial Prefocus	C	C-6	1.25	2.68	400 ⁽⁴⁾	72
17			25703	888	Traction Work Light	306	12.8	3.90A	95	Right Angle Prefocus	C	C-6	1.25	2.68	400 ⁽⁴⁾	73
18			41495	9012 (HIR2)*	Auto Headlamp Low Beam. Type HIR2. Halogen Infrared	304	12.8	56W	135	PX22D	C	C-8	1.25	2.8	900 ⁽⁴⁾	-
19			14776	9011	Auto Headlamp High Beam. Type HIR1. Halogen Infrared.	304	12.8	65W	183	PX20D	C	C-8	1.25	3.50	150 ⁽⁴⁾	108
20			47327	9011X HIR*	Auto Headlamp High Beam. Halogen Infrared.	304	12.8	65W	183	PX20D	C	C-8	1.25	3.50	150 ⁽⁴⁾	108
21	12359	27688		1816	Aircraft and Auto		13.0	.33A	3	Miniature Bayonet	B	C-2V ⁽¹³⁾	.62	1.19	1,000	70
22	27562		35030	W3W	Auto-European ECE		13.5	3W	1.75	Wedge	B	C-2V ⁽¹³⁾	.5	1.06	1,000	71
23		18442	18439	590	Sign Auto Strip Lighting (Xenon)		13.5	.37A	4	Wedge	C	C-2V	.5	1.06	2,000	71
24	25837			3652	Auto-Japanese Vehicles		13.5	.37A	6	Wedge	C	-	-	1.06	700	71
25	27563		37640	WSW	Auto-European ECE		13.5	5W	4	Wedge	C	C-2V ⁽¹³⁾	.5	1.06	300	71
26		39999	40000	658	Indicator		14.0	.08A	0.31	Wedge	B	C-2F	0.56	1.06	15,000	71
27		26593		756	Indicator		14.0	.08A	.31	Miniature Bayonet	B	C-2F	.62	1.19	15,000	70
28	23016	25956	16489	161	Auto, Instrument		14.0	.19A	1	Wedge	B	C-2F	.56	1.06	4,000	71
29			23036	PC161	Auto Instrument		14.0	.19A	1	Printed Circuit Socket	B	C-2F	.45	1.11	4,000	75

4. At 14 volts.

13. Supported.

17. Filament shielded.

160. Filament will generate specified mscp in a non shielded bulb.

304. See page 50.

306. See page 50.

MINIATURE LAMP SPECIFICATION

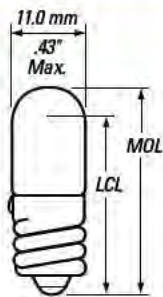

Fig. 69
T-3 1/4

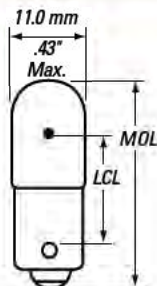

Fig. 70
T-3 1/4

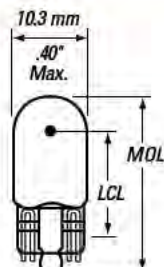

Fig. 71
T-3 1/4

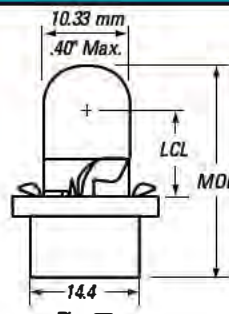

Fig. 75
T-3 1/4

(For standard 1/2" hole on P.C. Board)

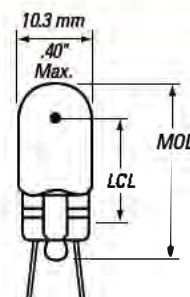

Fig. 111
T-3 1/4

Line No.	Order Code			GE Lamp No.	Primary Application	Safety Notes	Design Volts	Design Watts or Amps	Mean Spherical CP (Approx.)	Base	Atmosphere B-Vac./C-Gas	Filament Designation	Light Center Length (in.)	Max. Overall Length (in.)	Rated Average Lab Life (Hours)	Fig. No.
	Blister Pack	Unit Pack	Bulk Pack													
T-3 1/4 BULB 10mm DIAMETER (continued)																
1		27356		1487	Indicator		14.0	.20A	1.4	Miniature Screw	B	C-2F	.94	1.19	3,000	69
2		27677	27679	1815	Indicator		14.0	.20A	1.4	Miniature Bayonet	B	C-2F ⁽¹⁴⁷⁾	.75	1.19	3,000	70
3		25931	25933	158	Auto, Instrument, and Indicator		14.0	.24A	2	Wedge	B	C-2V ⁽¹³⁾	.56	1.06	500	71
4		25199	25200	591	Sign Auto Strip Lighting (Xenon)		14.0	.24A	2	Wedge	C	C-2V	.5	1.06	3,000	71
5	12331	27917		1891	Auto, Radio and Indicator		14.0	.24A	2	Miniature Bayonet	B	C-2F	.62	1.19	500	70
6	12328	25965	16303	194	Auto, Instrument		14.0	.27A	2	Wedge	B	C-2F	.56	1.06	2,500	71
7	12356			194B	Auto courtesy - Blue silicone coating ⁽¹³²⁾		14.0	.27A	2	Wedge	B	C-2F	-	1.06	2,500	71
8	12357			194G	Auto courtesy - Green silicone coating ⁽¹³²⁾		14.0	.27A	2	Wedge	B	C-2F	-	1.06	2,500	71
9	12319	44859	27470	194NA	Auto Side marker - Natural Amber bulb		14.0	.27A	1.5	Wedge	B	C-2F	-	1.06	2,500	71
10	47794			194NAXL*	Auto Side marker - Natural Amber bulb - Long Life		14.0	.27A	1.5	Wedge	B	C-2F	-	1.06	5,000	71
11	12355		21618	194R	Auto courtesy - Red silicone coating - Heavy Duty ⁽¹³²⁾		14.0	.27A	2	Wedge	B	C-2F	-	1.06	2,500	71
12	25832			194XL	Auto, Long Life		14.0	.27A	2	Wedge	B	C-2F	.56	1.06	12,000	71
13		27907		1889	Auto - Heavy Duty		14.0	.27A	2	Miniature Bayonet	B	C-2F	.56	1.19	2,000	70
14		72221	23021	PC194	Auto Inst. & Ind., H.D.		14.0	.27A	2	Printed Circuit Socket	B	C-2F	.45	1.11	2,500	75
15		19553	198	193	Heavy Duty Truck		14.0	.33A	2	Wedge	B	C-2F	.56	1.06	15,000	71
16			19921	193E	Heavy Duty Truck - 9/16" leads up		14.0	.33A	2	Wedge, Wire Terminal ⁽¹²²⁾	B	C-2F	.56	1.06	15,000	111
17			11807	193E-1	Truck Clearance - 9/16" leads up		14.0	.33A	2	Wedge, Wire Terminal ⁽¹²²⁾	B	C-2F	-	1.06	15,000	111
18	12332	27935	27937	1893	Auto - Heavy Duty		14.0	.33A	2	Miniature Bayonet	B	C-2F	.62	1.19	7,500	70
19	12327	25962	16302	168	Auto Instrument		14.0	.35A	3	Wedge	B	C-2F	.56	1.06	1,500	71
20	47827			168XL*	Auto Instrument-Long Life		14.0	.35A	3	Wedge	B	C-2F	.56	1.06	3,000	71
21			44964	22860	Auto/Truck		14.0	.35A	2.7	Wire Term Down	B	C-2F	-	1.05	1,500	-
22		27222	23037	PC168	Auto Instrument		14.0	.35A	3	Printed Circuit Socket	B	C-2F	.45	1.11	1,500	75
23		27667		1813	Radio		14.4	.10A	.86	Miniature Bayonet	B	C-2V ⁽¹³⁾	.62	1.19	1,000	70
24		27927		1892	Auto and Indicator		14.4	.12A	.75	Miniature Bayonet	B	C-2F	.62	1.19	1,000	70
25		27707		1818	Aircraft		24.0	.17A	3.3	Miniature Bayonet	B	C-2F ⁽¹⁴⁷⁾	.62	1.19	250	70
26		27816		1843	Indicator ⁽¹⁵⁾		28.0	.022A	.2	Miniature Bayonet	B	C-2F	.62	1.19	3,000	70
27		27711	27712	1819	Indicator		28.0	.04A	.34	Miniature Bayonet	B	C-2F	.62	1.19	2,500	70
28		38866		656	Indicator		28.0	.06A	.62	Wedge	B	C-2F	.56	1.06	2,500	71
29		27776		1829	Indicator		28.0	.07A	1	Miniature Bayonet	B	C-2F	.62	1.19	1,000	70
30		38196		657	Indicator		28.0	.08A	.62	Wedge	B	C-2F	.56	1.06	15,000 ⁽⁷⁵⁾	71

13. Supported.

15. This lamp is specially designed for a particular purchaser and may not be suitable for other uses because of its limited mechanical strength.

79. Life shown is AC voltage only. DC life will be approx. 50% of AC.

122. This is a wire terminal lamp. The glass-to-metal seal (and tip where applicable) are susceptible to damage by thermal shock, and soldering or welding within 1/8" of the glass should be avoided as glass cracks and air leaks may develop.

36 Solderability may be adversely affected by storage for an extended period in

excess of six months or by storage in a high humidity environment. Lamps with tinned leads would be subject to these storage restrictions. Nickel-plated leads are not recommended for soldering; however, their ability to be welded is not affected by these storage restrictions.

132. Paint may peel, craze or discolor when subjected to excessive moisture, heat, and freezing in housings with plugged drain holes or which otherwise leak or trap moisture.

147. Differs from ANSI.

MINIATURE LAMP SPECIFICATION

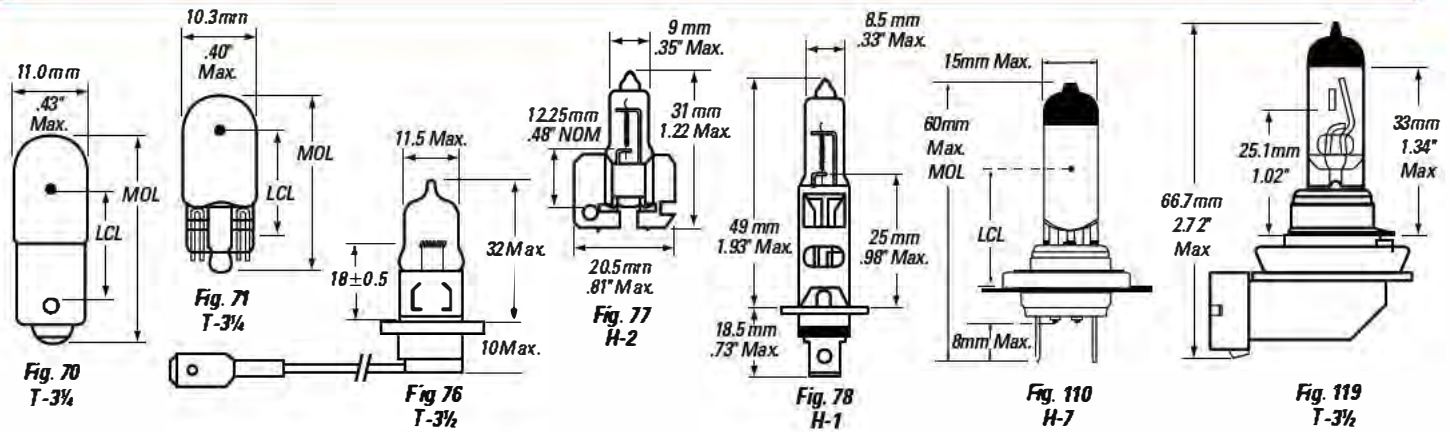

Line No.	Order Code			GE Lamp No.	Primary Application	Safety Notes	Design Volts	Design Watts or Amps	Mean Spherical CP (Approx.)	Base	Atmosphere B-Vac./C-Gas	Filament Designation	Light Center Length (in.)	Max. Overall Length (in.)	Rated Average Lab Life (Hours)	Fig. No.
	Blister Pack	Unit Pack	Bulk Pack													
T-3/4 BULB 13/32" (10mm) DIAMETER (continued)																
1		26599		757	Indicator		28.0	.08A	.62	Miniature Bayonet	B	C-2F	.62	1.19	5,000 (75)	70
2		38918		400	Aircraft		28.0	.10A	1.6	Wedge	B	C-2F	.56	1.06	1,000	71
3		27727		1820	Indicator		28.0	.10A	1.6	Miniature Bayonet	B	C-2F	.62	1.19	1,000	70
4		26212	26214	313	Aircraft		28.0	.17A	3.5	Miniature Bayonet	B	C-2F	.62	1.19	500	70
5		39645		464	Aircraft		28.0	.17A	3	Wedge	B	C-2F	.56	1.06	1,500	71
6		27862	27863	1864	Aircraft		28.0	.17A	3	Miniature Bayonet	B	C-2F	.62	1.19	1,500	70
7		40383		1873	Aircraft		28.0	.20A	3	Miniature Bayonet	B	C-2F	.62	1.19	7,000	70
8		27749		1822	Indicator		36.0	.10A	2.1	Miniature Bayonet	B	C-2F	.62	1.19	1,000	70
9		27772		1828	Indicator		37.5	.05A	.65	Miniature Bayonet	B	C-2F	.62	1.19	3,000	70
10		27804		1835	Indicator		55.0	.05A	1.1	Miniature Bayonet	B	C-2F	.62	1.19	5,000	70
TL-3/4 BULB 13/32" (10mm) DIAMETER																
11		38269		558	Auto and Indicator Lens end (68)		13.0	.33A	-	Wedge	C	C-2V (13)	-	1.06	500	71
T-3/2 BULB 7/16" (11.5mm) DIAMETER																
12			23442	50390 (H3-35)	C.I.M. H3-35W 12V	308	13.2	40W	60	P14.5S	C	C-6	.71	1.65	200	76
13			15765	HB*	Auto ECE Fog	308	13.2	40W	64	PGJ19-1	C	C-8	1.06	2.63	400 (4)	119
14			15828	H11*	Auto ECE Low Beam	308	13.2	59W	107	PGJ19-2	C	C-8	1.07	2.63	550 (4)	119
15			15963	H11LL*	Auto ECE Low Beam	308	13.2	59W	107	PGJ19-2	C	C-8	1.07	2.63	1,400 (4)	119
16	26374		35755	58520 (H7-55)	Auto ECE, DOT H7, 55W 12V	308	13.2	56.5W	115	PX26D	C	C-8	.98	2.36	500	110
17	40336	27328	32376	50310/1 (H1-55)	Auto ECE H1-55W 12V	308	13.2	62W	123	P14.5S	C	C-8	1.08	2.66	225	78
18	12339	27331	22132	50340 (H3-55)	Auto ECE H3-55W 12V	308	13.2	62W	115	P14.5S	C	C-6	.71	1.65	225	76
19			23445	50340HD (H3-55)	C.I.M. H3-55W 12V	308	13.2	62W	111	P14.5S	C	C-6	.71	1.65	600	76
20		27330	22130	50410 (H2-55)	Auto ECE H2-55W 12V	308	13.2	62W	143	P14.5S	C	C-8	.48	1.22	225	77
21			35044	50340LL (H3-55)	Auto ECE H3-55W 12V Long Life	308	13.2	64W	106	P14.5S	C	C-6	.71	1.65	2,000	76
22			15827	H9*	Auto ECE High Beam	308	13.2	69W	167	PGJ19-5	C	C-8	1.08	2.63	125 (4)	119
23	12341			52130 (H3-100)	Off Road Auxiliary H3-100W 12V	308	13.2	92W	187	P14.5S	C	C-6	.71	1.65	100	76
24		27329		52140 (H1-100)*	Off Road Auxiliary H1-100W 12V	308	13.2	100W	219	P14.5S	C	C-8	1.08	2.66	100	78
25			23428	52590HD	C.I.M. H3-65W 24V	308	28.0	66W	102	P14.5S	C	C-6	.71	1.65	1,000	76
26		27332	23438	50350	C.I.M. H3-70W 24V	308	28.0	79W	135	P14.5S	C	CC-6	.71	1.65	225	76
27		27569		50320/1	Auto. ECEH1 -70W/24V	308	28.0	80W	151	P14.5S	C	C-8	1.08	2.46	600	78

2. B₃ life, not average life.

4. At 14 volts.

13. Supported.

68. Uses lens-end TL-3/4 bulb. Provides 7,000 to 11,000 foot-candles in a 1/4" diameter spot at 1/8" from end of bulb.

79. Life shown is AC voltage only. DC life will be approx. 50% of AC.

308. See page 50.

MINIATURE LAMP SPECIFICATION

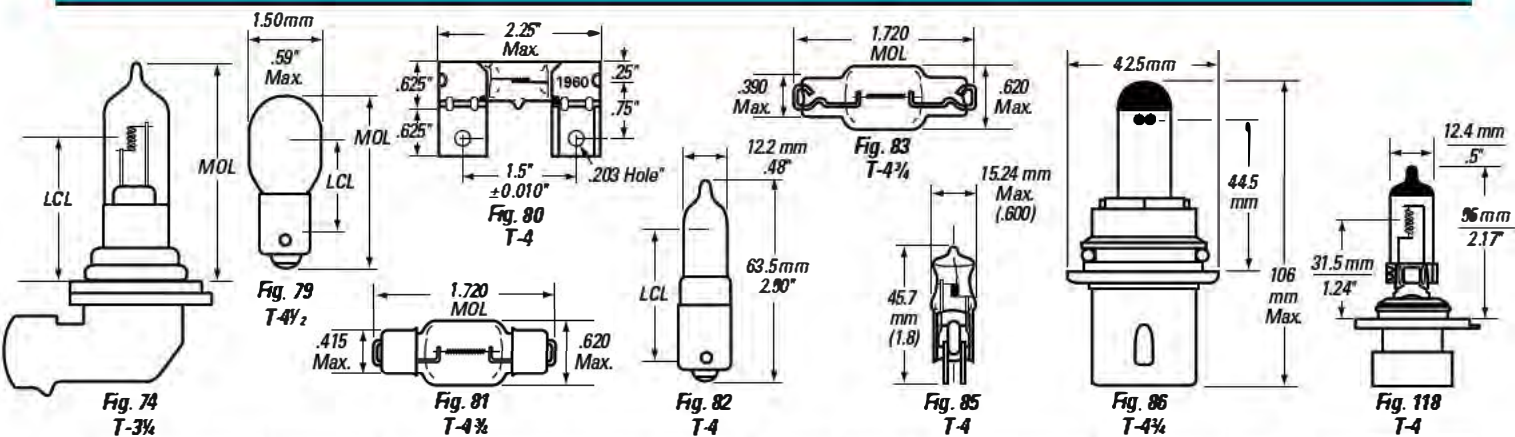

Line No.	Order Code			GE Lamp No.	Primary Application	Safety Notes	Design Volts	Design Watts or Amps	Mean Spherical CP (Approx.)	Base	Atmosphere B-Vac./C-Gas	Filament Designation	Light Center Length (in.)	Max. Overall Length (in.)	Rated Average Life (Hours)	Fig. No.
	Blister Pack	Unit Pack	Bulk Pack													
T-4 BULB 1/2" (13mm) DIAMETER																
1		39718		1983	Aircraft - Navigation - Quartz bulb	304	10.0	100W	130	Two Pin	C	C-8	1.25	1.80	2,000	85
2	40843		37735	9145(H1D)*	Auto Fog ECEH10	306	12.8	45W	65	PY20D	C	C-8	1.24	3.01	1,500 ⁽⁴⁾	
3	20469		795		Signal - Halogen	306	12.8	50W	108	S.C. Bayonet	C	C-6	1.25	2.50	200 ⁽⁴⁾	82
4	18510	13397	14711	9006/HB4	Auto Headlamp, Low Beam. Type HB4	306	12.8	55W	80	Right Angle Plastic, Prefocus	C	C-8	1.24	3.13	850 ⁽⁴⁾	74
5	47640			9006HO*	Auto Headlamp, Low Beam. HB4. Higher Output	306	12.8	55W	80	Right Angle Plastic, Prefocus	C	C-8	1.24	3.13	1000 ⁽⁴⁾	74
6	45473			9006SB*	Auto Headlamp, Low Beam. HB4. Coated for White Light	306	12.8	55W	80	Right Angle Plastic, Prefocus	C	C-8	1.24	3.13	320 ^(4,75)	74
7	45868			9006XSLL*	Auto Headlamp, Low Beam. Type HB4A. Axial Base	306	12.8	55W	80	Axial Plastic Prefocus	C	C-8	1.24	3.13	2,000 ⁽⁴⁾	118
8	18509	13384	14710	9005/HB3	Auto Headlamp, High Beam. Type HB3	306	12.8	65W	135	Right Angle Plastic, Prefocus	C	C-8	1.24	3.13	800 ⁽⁴⁾	74
9	45472			9005SB*	Auto Headlamp, High Beam. HB3. Coated for White Light	306	12.8	65W	135	Right Angle Plastic, Prefocus	C	C-8	1.24	3.13	150 ^(4,75)	74
10	45866			9005XSLL*	Auto Headlamp, High Beam. Type HB3A. Axial Base	306	12.8	65W	135	Axial Plastic Prefocus	C	C-8	1.24	3.13	700 ⁽⁴⁾	118
11		28011		1958	Aircraft - Quartz bulb - Halogen	304	28.0	150W	250	Tab	C	CC-8	.75	2.25	300	80
12		47695		1987	Aircraft - Quartz bulb	304	28.0	150W	240	D.C. Bayonet	C	CC-6	1.18	2.44	700	-
13		44717		1986	Aircraft - Quartz bulb	304	28.0	250W	600	Wire Terminal	C	CC-6	1.03	2.00	100	-
14			19566	2586	Aircraft - Quartz bulb	304	28.0	250W	600	S.C. Prefocus Collar Two Pin with Insulation Leads	C	CC-6	1.30	1.90	100	-
T-4 1/2 BULB 3/16" (14mm) DIAMETER																
15		27392		1495	Aircraft ⁽¹⁴⁾		28.0	.30A	6	Miniature Bayonet	B	C-2F	.62	1.38	500	79
16		44842		1495X	Aircraft - Gas filled		28.0	.30A	6	Miniature Bayonet	C	C-2F	.62	1.38	500	79
T-4 3/4 BULB 1/2" (15.2mm) DIAMETER																
17	23020			577	Auto		12.8	1.40A	21	Double End Cap	C	C-8	-	1.72	1,000	81
18	12672			570	Truck Bed Light		12.8	2.10A	32	Rigid Loop	C	C-8	-	1.72	600	83
19	18508	13382	18699	9004/HB1	Auto Headlamp High/Low Beam. Type HB1	306	12.8	65W	95 ⁽¹⁶⁾	Axial Plastic Prefocus	C	C-6	-	4.17	150 ⁽⁴⁾	86
							12.8	45W	55 ⁽¹⁶⁾		C	C-6	1.75	-	320	
20	27561			9004HO*	Auto Headlamp High/Low Beam. HB1. Higher output.	306	12.8	65W	95 ⁽¹⁶⁾	Axial Plastic Prefocus	C	C-6	-	4.17	150 ⁽⁴⁾	86
							12.8	42W	56 ⁽¹⁶⁾		C	C-6	1.75	-	640	
21	45471			9004SB*	Auto Headlamp High/Low Beam. HB1. Coated for White Light.	306	12.8	65W	95 ⁽¹⁶⁾	Axial Plastic Prefocus	C	C-6	-	4.17	40 ⁽⁴⁾	86
							12.8	45W	56 ⁽¹⁶⁾		C	C-6	1.75	-	200	
22	13993	11249	20559	9004XL	Auto Headlamp Long Life High/Low Beam. HB1	306	12.8	65W	95 ⁽¹⁶⁾	Axial Plastic Prefocus	C	C-6	-	4.17	150 ⁽⁴⁾	86
							12.8	47W	55 ⁽¹⁶⁾		C	C-6	1.75	-	850	

4. At 14 volts.

161. MSCP measured with black top.

75. Estimated. Based on limited test information.

304. See page 50.

306. See page 50.

MINIATURE LAMP SPECIFICATION

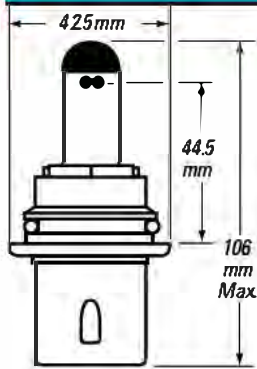

Fig. 86
T-4 1/4

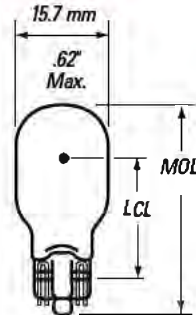

Fig. 87
T-5

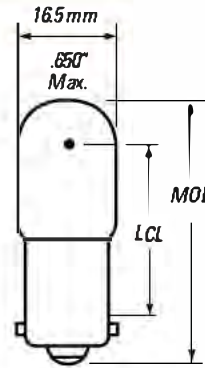

Fig. 88
T-5

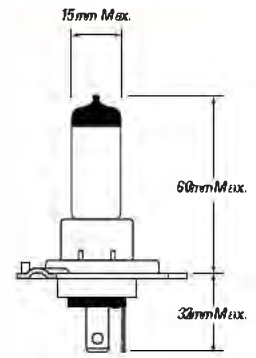

Fig. 107
T-5

Line No.	Order Code			GE Lamp No.	Primary Application	Safety Notes	Design Volts	Design Watts or Amps	Mean Spherical CP (Approx.)	Base	Atmosphere B-Vac./C-Gas	Filament Designation	Light Center Length (in.)	Max. Overall Length (in.)	Rated Average Lab Life (Hours)	Fig. No.
	Blister Pack	Unit Pack	Bulk Pack													
T-4 1/4 BULB #/32" (15.2mm) DIAMETER (continued)																
1	22388	20551		9007/HB5	Auto Headlamp High/Low Beam. Type HB5.	306	12.8	65W	107 ⁽¹⁶¹⁾	Axial Plastic Prefocus	C	C-8	-	4.17	150 ⁽⁴⁾	86
2	47642			9007H0*	Auto Headlamp High/Low Beam. HB5. Higher Output.	306	12.8	65W	107 ⁽¹⁶¹⁾	Axial Plastic Prefocus	C	C-8	-	4.17	150 ⁽⁴⁾	86
3			10209	9007LL	Auto Headlamp High/Low Beam. HB5. Long life	306	12.8	65W	107 ⁽¹⁶¹⁾	Axial Plastic Prefocus	C	C-8	-	4.17	150 ⁽⁴⁾	86
4	45474			9007SB*	Auto Headlamp High/Low Beam. HB5. Coated for White Light	306	12.8	65W	107 ⁽¹⁶¹⁾	Axial Plastic Prefocus	C	C-8	-	4.17	110 ⁽⁴⁾	86
5	22432	22389	14542	9003/HB2	Auto Headlamp High/Low Beam. Type HB2/H4	306	12.8	67W	119	P43T-38	C	C-8	1.12	3.62	150 ⁽⁴⁾	107
6	45470			9003SB*	Auto Headlamp High/Low Beam. Coated for White Light.	306	12.8	60W	72	P43T-38	C	C-8	1.12	3.62	80 ⁽⁴⁾	107
T-5 BULB #/16" (16mm) DIAMETER																
7		27889		1876	Photoelectric Scanner - Silver Plated contact (A.A. Tol. 1/64")		3.5	2.50A	6.5	S.C. Bayonet	C	C-6	1.12	1.75	2,000	88
8		27193		1434	Instrument, Photocell exciter - Silver Plated contact		3.7	2.75A	11	S.C. Bayonet	C	C-6	1.12	1.75	100	88
9		44769		914	Emergency Lighting		4.0	.90A	3.5	Wedge	C	C-6	0.75	1.49	50	87
10		13483		926	Emergency Lighting		4.0	1.80A	7.5	Wedge	C	C-2R	0.81	1.49	50	87
11		44756	44757	909	Emergency Lighting		6.0	.62A	3	Wedge	C	C-2R	0.81	1.49	50	87
12		16975	15285	939	Emergency Lighting		6.0	.90A	5.4	Wedge	C	C-2R	0.81	1.49	50	87
13		13485	13486	927	Emergency Lighting		6.0	1.20A	8	Wedge	C	C-2R	0.81	1.49	50	87
14		44754	44755	908	Emergency Lighting		6.0	1.50A	12	Wedge	C	C-2R	0.81	1.49	50	87
15		44771	44772	915	Emergency Lighting		12.0	.75A	11	Wedge	C	C-2R	0.81	1.49	50	87
16	14273		14007	901	Garden & Security Lighting		12.8	.31A	2.9	Wedge	C	C-2R	0.81	1.49	500	87
17	40675			901A*	Garden & Security Lighting - Amber/Yellow Coating		12.8	.31A	-	Wedge	C	C-2R	0.81	1.49	500	87
18	40179	17837	14008	918	Garden & Security Lighting		12.8	.56A	6.5	Wedge	C	C-2R	.81	1.49	500	87
19	40180			923	Garden & Security Lighting		12.8	.91A	12.5	Wedge	C	C-2R	.81	1.49	500	87
20	23027	13274	13275	922	Auto - Heavy Duty		12.8	.98A	15	Wedge	C	C-2R	.81	1.49	200	87
21	12365	40504	40505	912	Auto - Heavy Duty		12.8	1.00A	12	Wedge	C	C-2R	.81	1.49	1,000	87
22	26199			920	Auto		12.8	1.20A	10	Wedge	C	-	.81	1.49	1,200	87
23	12307	43374	11743	921	Auto - Heavy Duty ⁽¹²¹⁾		12.8	1.40A	21	Wedge	C	C-2R	.81	1.49	500	87
24	23026	21860		916NA	Auto, Side Marker, Natural Amber		13.0	.54A	1.5	Wedge	C	C-2F	.81	1.49	10,000	87
25	12366	40289	40290	906	Auto - Heavy Duty		13.0	.69A	6	Wedge	C	C-2F	.81	1.49	1,000	87
26			48505	906A*	Auto, Side Signal-Amber/Yellow Coating		13.0	.69A	-	Wedge	C	C-2F	.81	1.49	1,000	87

4. At 14 volts.

75. Estimated. Based on limited test information.

121. To minimize the possible adverse effects on lamp life due to excessive wattage in relationship to bulb size: Burn Base Down to Base 45° Above

Horizontal. Regardless of burning position, this excessive wattage will abnormally decrease light output during lamp life.

161. MSCP measured with black top.

306. See page 50.

MINIATURE LAMP SPECIFICATION

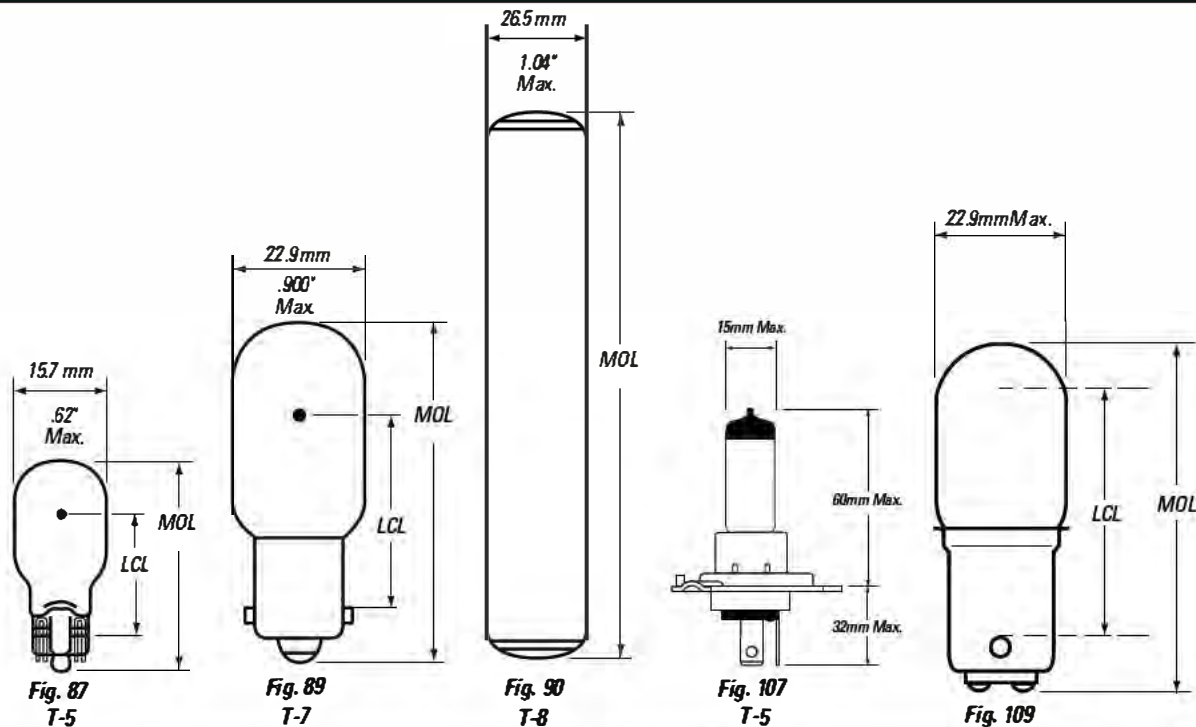

Line No.	Order Code			GE Lamp No.	Primary Application	Safety Notes	Design Volts	Design Watts or Amps	Mean Spherical CP (Approx.)	Base	Atmosphere B-Vac./C-Gas	Filament Designation	Light Center Length (in.)	Max. Overall Length (in.)	Rated Average Lab Life (Hours)	Fig. No.
	Blister Pack	Unit Pack	Bulk Pack													
T-5 BULB 5/8" (16mm) DIAMETER (continued)																
1	18132	27334	22133	50440 (H4-60/55)	Auto ECE H4-12V 60/55W	306	13.2	71W	138	P43T-38	C	C-8	1.12	3.62	225	107
								66W	80			C-8			900	
2	23025	16289	16288	916	Auto, Side Marker		13.5	54A	2	Wedge	C	C-2F	.81	1.49	10,000	87
3	23024	40462	40463	904	Auto - Heavy Duty		13.5	69A	4	Wedge	C	C-2F	.81	1.49	5,000 ⁽⁴⁾	87
4			26353	W16W	Auto ECEW16W ⁽¹²⁾		13.5	1.44A	24.6	Wedge	C	C-2F	.81	1.49	250	87
5		27342	30833	50450 (H4-75/ 70/28V)	Bus ECE H4 H4-24V 75/70W	308	28.0	80W	151	P43T-38	C	C-8	1.14	3.62	150	107
							28.0	73W	95			C-8			300	
T-7 BULB 7/8" (20mm) DIAMETER																
6	25834			3496	Auto Stop, Tail		12.8	2.10A	43	D.C. Index	C	C-6	-	2.00	600	109
					Japanese Vehicles		14.0	.59A	3		C	C-6			5,000	
7	25835			3497	Auto Stop, Signal		12.8	2.10A	45	S.C. Bayonet	C	C-6	-	2.00	600	89
					Japanese Vehicles											
8	26200			7440	Auto Stop, Signal		13.5	1.85A	37	Wedge/ 103x 16D	C	C-6	-	1.75	300	-
					Japanese Vehicles											
9	26201		10014	7443	Auto Stop, Tail		13.5	1.85A	35	Wedge/ 103x 16D	C	C-6	-	1.75	500	-
					Japanese Vehicles		13.5	0.4A	3		C	C-6			1,000	
10		28008		1940	Aircraft Marker		14.0	3.57A	75	S.C. Bayonet	C	C-8Z	1.25	2.16	300	89
11		37034		1944	Special Service - Silver contact		14.0	3.57A	75	S.C. Bayonet	C	C-8Z	1.25	2.25	300	89
12		34021		1939X	Aircraft Marker		28.0	1.79A	70	S.C. Bayonet	C	C-2V ⁽¹³⁾	1.25	2.16	300	89
T-8 BULB 1" (22mm) DIAMETER																
13		12571		ML20/ OF-28	Aircraft - Lumiline - Inside Frosted		28.0	20V	-	Disk	B	2C-8	-	5.75 ⁽¹⁴⁾	500	90

4. At 14 volts.

12. Average overall length.

13. Supported.

121. To minimize the possible adverse effects on lamp life due to excessive wattage in relationship to bulb size: Burn Base Down to Base 45° Above

Horizontal. Regardless of burning position, this excessive wattage will abnormally decrease light output during lamp life.

306. See page 50.

308. See page 50.

MINIATURE LAMP SPECIFICATION

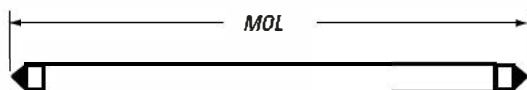

Fig. 93
T-5

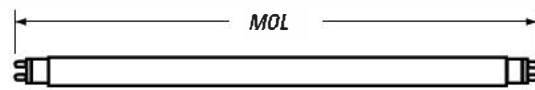

Fig. 94
T-5

Line No.	Order Code			GE Lamp No.	Primary Application	Safety Notes	Design Volts	Design Watts or Amps	Approx. Lumens**	Base	Bulb	Nominal Overall Length (in.)	Rated Average Lab Life (Hours)	Fig. No.
	Blister Pack	Unit Pack	Bulk Pack											
ELECTRIC DISCHARGE LAMPS – FLUORESCENT T-5 BULB 5/8" (16mm) DIAMETER***														
1		28154		5004CW	Aircraft – Cool White	309	A.C.	4W	150	Miniature Pinless	T5	6.00	7,500 ⁽¹⁶²⁾	93
2		28155		5004WW	Aircraft – Warm White	309	A.C.	4W	140	Miniature Pinless	T5	6.00	7,500 ⁽¹⁶²⁾	93
3		27367		5104CW*	Aircraft – Cool White	309	A.C.	4W	150	Miniature Bi-Pin	T5	6.00	7,500 ⁽¹⁶²⁾	94
4		28173		5104WW	Aircraft – Warm White	309	A.C.	4W	140	Miniature Bi-Pin	T5	6.00	7,500 ⁽¹⁶²⁾	94
5		12774		5106CW	Aircraft – Cool White	309	A.C.	6W	310	Miniature Bi-Pin	T5	9.00	7,500 ⁽¹⁶²⁾	94
6		33612		5106WW	Aircraft – Warm White	309	A.C.	6W	300	Miniature Bi-Pin	T5	9.00	7,500 ⁽¹⁶²⁾	94
7		28160		5008CW	Aircraft – Cool White	309	A.C.	8W	445	Miniature Pinless	T5	12.00	7,500 ⁽¹⁶²⁾	93
8		28163		5008WW	Aircraft – Warm White	309	A.C.	8W	435	Miniature Pinless	T5	12.00	7,500 ⁽¹⁶²⁾	93
9		27466		5108CW*	Aircraft – Cool White	309	A.C.	8W	445	Miniature Bi-Pin	T5	12.00	7,500 ⁽¹⁶²⁾	94
10		28175		5108WW	Aircraft – Warm White	309	A.C.	8W	435	Miniature Bi-Pin	T5	12.00	7,500 ⁽¹⁶²⁾	94
11		28168		5013CW	Aircraft – Cool White	309	A.C.	13W	820	Miniature Pinless	T5	21.00	7,500 ⁽¹⁶²⁾	93
12		28169		5013WW	Aircraft – Warm White	309	A.C.	13W	790	Miniature Pinless	T5	21.00	7,500 ⁽¹⁶²⁾	93
13		12775		5113CW	Aircraft – Cool White	309	A.C.	13W	820	Miniature Bi-Pin	T5	21.00	7,500 ⁽¹⁶²⁾	94
14		28178		5113WW	Aircraft – Warm White	309	A.C.	13W	790	Miniature Bi-Pin	T5	21.00	7,500 ⁽¹⁶²⁾	94

162. Based on three hours of burning per start.

309. See page 50.

** Measured at 100 hours.

*** Designed and rated for operation in supplementary cathode preheat circuits. Use these lamps with auxiliary equipment specially designed to produce proper electrical values conforming to established specification. For total load, add auxiliary watts to lamp watts.

CENTRAL DISCHARGE LAMP SPECIFICATION

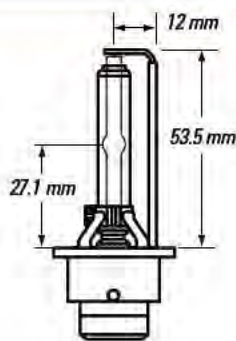

Fig. 117
T-3

Line No.	Order Code			GE Lamp No.	Primary Application	Safety Notes	Design Volts	Design Watts or Amps	Mean Spherical CP (Approx.)	Base	Atmosphere B-Vac./C-Gas	Filament Designation	Light Center Length (in.)	Max. Overall Length (in.)	Rated Average Lab Life (Hours)	Fig. No.
	Blister Pack	Unit Pack	Bulk Pack													
ELECTRIC DISCHARGE LAMPS – HEADLAMP T-3 BULB 3/8" (9.5mm) DIAMETER																
15			16124	D2R*	Auto Low Beam Reflector System ⁽¹⁾	308	85	35W	114	P32d-2	C	—	1.06	3.09	1,000 ⁽²⁾	117
16			15999	D2S*	Auto Low Beam Projector System ⁽¹⁾	308	85	35W	254	P32d-2	C	—	1.06	3.09	1,000 ⁽²⁾	117

1. Special ballast required per ECE R99.

2. B₃ life, not average life.

NEON GLOW INDICATOR LAMPS

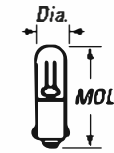

Fig. 96

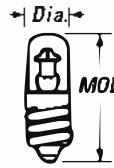

Fig. 97

Line No.	Order Code			GE Lamp No.	Circuit Volts AC or DC	Nom. Watts	Nom. Current	Base	Maximum Overall Length in. (mm)	Average Useful Life (Hours)	Series# Resistance (Ohms)	Footnotes	Fig. No.
	Blister Pack	Unit Pack	Bulk Pack										
T-3¹/₄ APPROX. ¹³/₃₂" (10mm) DIAMETER													
1		12064		B1A (NE-51)	105-125	1/25	.0003A	Miniature Bayonet	1 ³ / ₁₆ (30.2)	15,000	220K	164	96
2		12065		B2A (NE-51H)	105-125	1/3	.0012A	Miniature Bayonet	1 ³ / ₁₆ (30.2)	25,000	47K	164	96
T-4¹/₂ APPROX. ⁹/₁₆" (14mm) DIAMETER													
3		31675		B7A (NE-45)	105-125	1/4	.002A	Candelabra Screw	1 ¹⁷ / ₃₂ (38.9)	7,500	30K	164	97

164. Life to approximately 50% of initial output. Values shown apply to use on AC unless otherwise shown. Life on DC is approximately 60% of AC values when DC current is equal to R.M.S. (Root Mean Square) AC value. When equal DC

and R.M.S. AC voltages and equal resistances are utilized, life will be approximately the same.

FESTOON TYPE, AUTO & SPECIAL SERVICE LAMPS

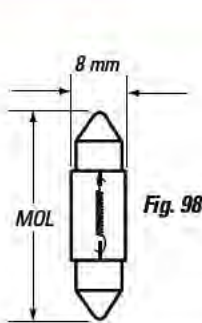

Fig. 98

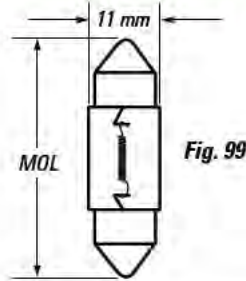

Fig. 99

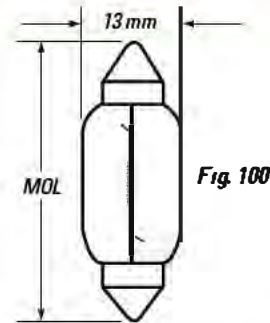
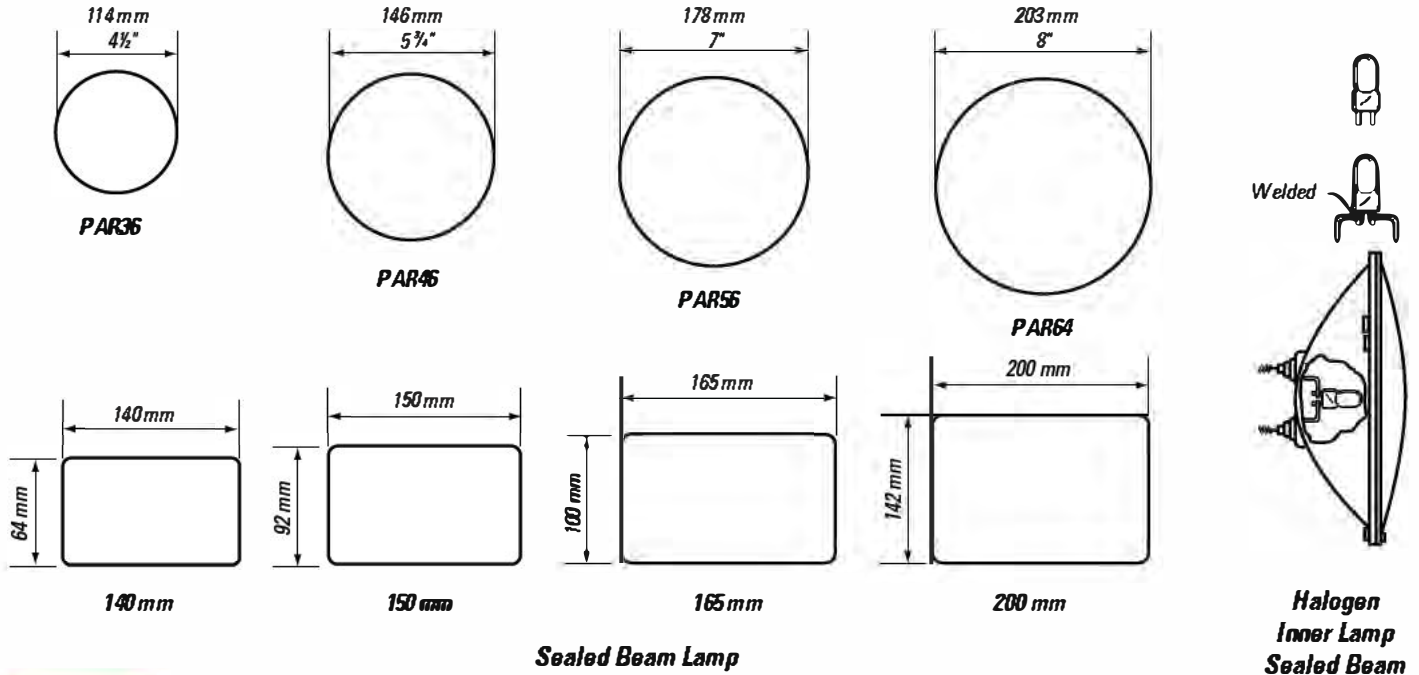

Fig. 100

Line No.	Order Code			GE Lamp No.	Primary Application	Design Volts	Design Watts or Anps	Mean Spherical CP (Approx.)	Base	Base Marking	Atmosphere B-V ac./ C-Gas	Max. Overall Length in. (mm)	Rated Average Lab Life (Hours)	Fig. No.
	Blister Pack	Unit Pack	Bulk Pack											
Festoon Type, Auto & Special Service Lamps														
4	23312		30872	C5W	Auto. ECE C5W	13.5	.37A	3.6	SV8.5/8	12V 5W-C5W	B	1.45 36	450	99
5	25323			DE3021	Dome & Courtesy	14.0	.24A	2	SV7MM	12V 3W	B	1.15 28	1,000	98
6	12353			DE3022	Dome & Courtesy	13.0	.38A	3	SV7MM	12V 5W	B	1.18 29	1,000	98
7	12354	12084		DE3175	Dome & Courtesy	13.0	.77A	9.55	SV8.5MM	12V 10W	B	1.25 31	400	99
8		12085		DE3425	Dome & Courtesy	13.0	.77A	9.55	SV8.5MM	12V 10W	B	1.50 37	400	100
9	23324			DE7576	Strip. Auto DIN 72601K	13.5	.74A	9.8	SV8.5/8	12V 10W	C	1.65 41	200	99

SEALED BEAM, FILAMENTS & BASES (Typical)

Bulbs



Filaments

Filaments for sealed beam lamps may be a coil (C) or a coiled coil (CC) wire. Coiling the filament wire reduces gas losses and increases efficiency. The number following the coil identification letter(s) denotes the arrangement of the filament on the supports.

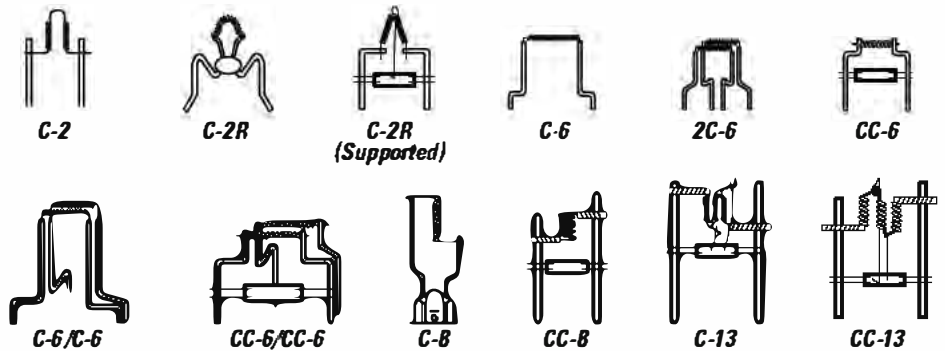

Bases

Bases provide electrical contact to the lamp. The most common bases for sealed beam lamps are the screw terminal and contact lug types. Other types are also available, as illustrated.

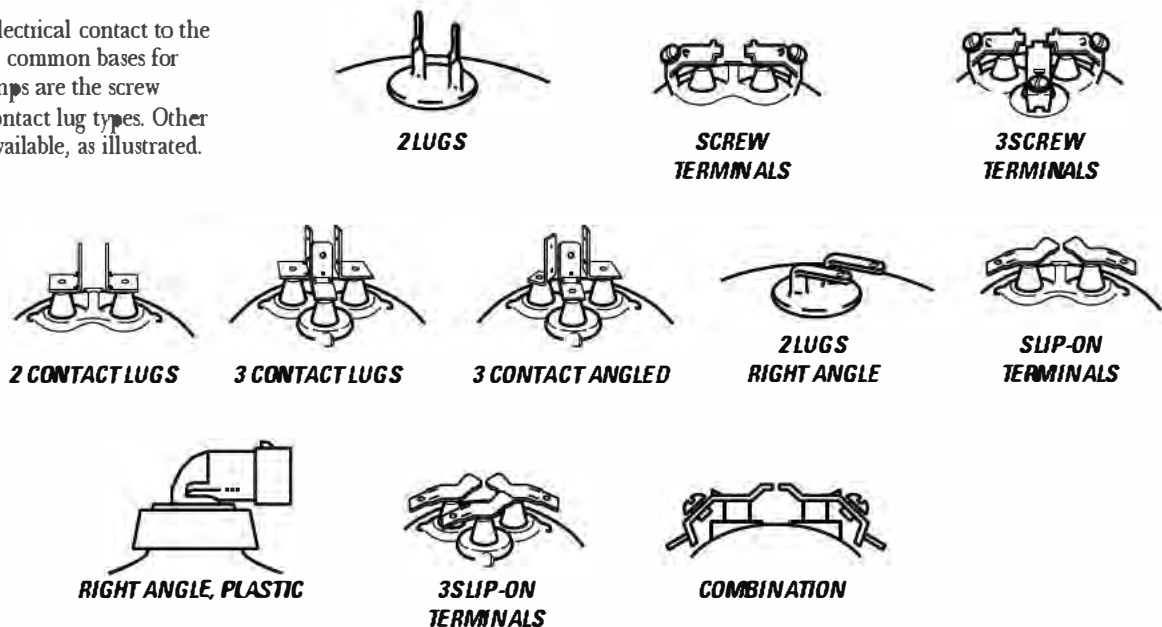

SEALED BEAM LAMP SPECIFICATIONS

Line No.	Order Code			GE Lamp No.	Primary Application	Safety Notes	Design Vols	Design Watts or Amps	Approx. Initial Max. Beam C.P.	Approx. Total Spread to 10% Max. C.P. - Degrees		Rated Average Lab Life (Hours)	Base	Filament Designation	Max. Overall Length	
	Blister Pack	Unit Pack	Bulk Pack							Horiz.	Vert.				mm	(in.)
RECTANGULAR 72mm x 140mm (2.8 in x 5.5 in)																
1			18350	H4360	Tractor	307	12.8	37.5W	2,000	Trapezoidal		320	2 Right Angle Lugs	C-6	76	3.00
2			41453	H5360*	Halogen Tractor Work Light	307	12.8	37.5W	2,000	Trapezoidal		900	2 Right Angle Lugs	C-6	76	3.00
3		22386		H4351	Auto Headlamp Low Beam Type K	307	12.8	55W	SAE Specifications		500	Right Angle, Plastic	C-8	102	4.00	
4		10211		H4351LH*	Headlamp - Left Hand Drive - Export only	307	12.8	55W	—		500	Right Angle, Plastic	C-8	102	4.00	
5		22387		H4352	Auto Headlamp, Upper Beam Type K	307	12.8	65W	SAE Specifications		150	Right Angle, Plastic	C-8	102	4.00	
RECTANGULAR 92mm x 150mm (3.6 in x 5.9 in)																
6		16484	16483	H9415	Auto, Fog - Halogen	307	12.8	37.5W	12,000	45	5	200 ⁽⁴⁾	2 Right Angle Lugs	C-6	76	3.00
7		17988		H9415A	Auto Fog Amber	307	12.8	37.5W	—	45	5	200 ⁽⁴⁾	2 Right Angle Lugs	C-6	76	3.00
8		15767	15763	H9405	Spotlamp, Halogen	307	12.8	50W	100,000	7	4	100	2 Right Angle Lugs	C-6	76	3.00
9		15769	15768	H9406	Tractor, Flood, Halogen	307	12.8	50W	1,350	70	30	400 ⁽⁴⁾	2 Right Angle Lugs	C-6	76	3.00
10		15771	15770	H9411	Tractor, Trapezoidal, Halogen	307	12.8	50W	5,400	Trapezoidal		400 ⁽⁴⁾	2 Right Angle Lugs	C-6	76	3.00
11			15772	H9414	Tractor, Emergency Lighting, Medium Flood, Halogen	307	12.8	50W	2,700	45	20	400 ⁽⁴⁾	2 Right Angle Lugs	C-6	76	3.00
12		16976	16978	H9420	Auto, Driving - Halogen	307	12.8	50W	47,000	15	5	200 ⁽⁴⁾	2 Right Angle Lugs	C-6	76	3.00
13		16482		H9421	Auto, Truck, Special Service - Halogen ⁽¹⁰⁹⁾	307	12.8	50W	4,000	45	8	200 ⁽⁴⁾	2 Right Angle Lugs	C-6	76	3.00
14		18538	48534	H4703	Auto Headlamp, Low Beam Type LF	307	12.8	55W	SAE Specifications		320	2 Lugs	C-8	85	3.40	
15		18536	48533	H4701	Auto Headlamp High Beam Type UF	307	12.8	65W	SAE Specifications		150	2 Lugs	C-8	85	3.40	
RECTANGULAR 100mm x 165mm (4.2 in x 6.5 in)																
16		18533	49810	H4656	Auto Headlamp, Low Beam, Type 2A1	HI LO	307 12.8	35W 35W	SAE Specifications		200 ⁽⁴⁾ 320 ⁽⁴⁾	3 Contact Lugs	C-6	121	4.80	
17		18518		4652	Auto Headlamp, Low Beam, Type 2A1	HI LO	307 12.8	40W 60W	SAE Specifications		200 ⁽⁴⁾ 320 ⁽⁴⁾	3 Contact Lugs	C-6	121	4.80	
18		14753		H4656H0	Auto Headlamp, Low Beam, Type 2A1. Higher output	HI LO	307 12.8	40W 55W	SAE Specifications		200 ⁽⁴⁾ 700	3 Contact Lugs	C-8	121	4.80	
19		45475		H4656SB*	Auto Headlamp, Low Beam, Type 2A1. Coated for White Light	HI LO	307 12.8	40W 55W	SAE Specifications		75 ⁽⁴⁾ 200	3 Contact Lugs	C-8	121	4.80	
20		19412	19557	H5062	Truck Headlamp, High/Low Beam, Type 2A1. Long Life.	HI LO	307 12.8	40W 55W	SAE Specifications		400 ⁽⁴⁾ 2,000 ⁽⁴⁾	3 Contact Lugs	C-6	121	4.80	
21		18517	41861	4651	Auto Headlamp, High Beam, Type 1A1	HI	307	50W	SAE Specifications		200 ⁽⁴⁾	2 Contact Lugs	C-6	121	4.80	
22		45110	45111	4912-1	Auto/Truck Fog	HI	307	50W	14,000	40	7	300	Slip-on Terminals	C-6	115	4.53
23			45113	4913-1	Farm Tractor, Flood	HI	307	50W	1,350	80	20	400 ⁽⁴⁾	Slip-on Terminals	C-6	115	4.53
24		18532	45027	H4651	Auto Headlamp, High Beam, Type 1A	HI	307	50W	SAE Specifications		200 ⁽⁴⁾	2 Contact Lugs	C-6	121	4.80	
25		46375		H4651SB*	Auto Headlamp, High Beam, Type 1A. Coated For White Light	HI	307	50W	SAE Specifications		200 ⁽⁴⁾	2 Contact Lugs	C-6	121	4.80	
26		19411	19556	H5051	Truck Headlamp, High Beam, Type 1A. Long Life	HI	307	50W	SAE Specifications		500 ⁽⁴⁾	2 Contact Lugs	C-6	121	4.80	
27			13426	H7921-1	Halogen Auto/Truck Special Service ⁽¹⁰⁹⁾	HI	307	50W	23,900	35	5	200 ⁽⁴⁾	Slip-on Terminals	C-6	115	4.53
28		47460	14892	H7935-1	Halogen Spotlamp	HI	307	50W	175,000	6.5	3.5	100	Slip-on Terminals	C-6	115	4.53
29		18535	22879	H4666	Auto Headlamp, High/Low Beam, 2E1	HI LO	307 12.8	65W 55W	SAE Specifications		150 ⁽⁴⁾ 320 ⁽⁴⁾	3 Contact Lugs ⁽¹⁶⁶⁾	C-8	121	4.80	

4. At 14 volts.

166. Contact lugs are angled. See drawing page 43.

109. Special fixture required for highway use.

307. See page 50.

SEALED BEAM LAMP SPECIFICATIONS

Line No.	Order Code			GE Lamp No.	Primary Application	Safety Notes	Design Volts	Design Watts or Amps	Approx. Initial Max. Beam C.P.	Approx. Total Spread to 10% Max. C.P. - Degrees		Rated Average Lab Life (Hours)	Base	Filament Designation	Max. Overall Length	
	Blister Pack	Unit Pack	Bulk Pack							Horiz.	Vert.				mm	(in.)
RECTANGULAR 100mm x 165mm (4.2 in x 6.5 in) (continued)																
1			23250	H7913HIR	Farm Tractor, Flood Halogen Infrared	301	12.8	65W	4,000	70	20	800	2 Contact Lugs	C-8	121	4.80
2		45116	16195	4921-1	Auto/Truck, Special Service ⁽¹⁰⁹⁾	307	13.0	100W	25,000	40	7	300	Slip-on Terminals	C-6	115	4.53
RECTANGULAR 142mm x 200mm (5.6 in x 7.9 in)																
3		18521		6052	Auto Headlamp, Type 2B1	HI 307	12.8	65W	SAE Specifications			150 ⁽⁴⁾	3 Contact Lugs	C-6	138	5.44
						LO	12.8	55W				320 ⁽⁴⁾		C-6		
4		19429	19558	H5054	Truck Headlamp, High/Low Beam, Type 2B1, Long Life	HI 307	12.8	65W	SAE Specifications			400 ⁽⁴⁾	3 Contact Lugs	C-6	138	5.44
						LO	12.8	42W				2000 ⁽⁴⁾		C-6		
5		18534	11545	H6054	Auto Headlamp, High/Low Beam, Type 2B1	HI 307	12.8	65W	SAE Specifications			150 ⁽⁴⁾	3 Contact Lugs	C-6	138	5.44
						LO	12.8	35W				320 ⁽⁴⁾		C-6		
6		14752		H6054HO	Auto Headlamp, High/Low Beam, Type 2B1, Higher Output.	HI 307	12.8	65W	SAE Specifications			150 ⁽⁴⁾	3 Contact Lugs	C-8	138	5.44
						LO	12.8	55W				700 ⁽⁴⁾		C-8		
7		45477		H6054SB*	Auto Headlamp, High/Low Beam, Type 2B1, Coated for White Light	HI 307	12.8	65W	SAE Specifications			75 ⁽⁴⁾	3 Contact Lugs	C-8	138	5.44
						LO	12.8	55W				200 ⁽⁴⁾		C-8		
PAR36 BULB 114mm (4½ in) DIAMETER																
8		24780	24783	4546	Hand Lantern		4.7	.5A	6,300	3	3	100	Screw Terminals	C-2R	70	2.75
9		24770	24775	4546-1	Hand Lantern		4.7	.5A	6,300	3	3	100	Slip-on Terminals	C-2R	70	2.75
10		24788		4547	Hand Lantern		4.75	1.25A	20,000	3	3	100	Screw Terminals	C-2R	70	2.75
11		44924	44925	H7556	Halogen Emergency Bldg. Lighting	307	6.0	6W	400	30	20	50	Screw Terminals	C-6	70	2.75
12		11421	11422	7672-1	Emergency Bldg. Lighting		6.0	7.2W	350	30	20	50	Slip-on Terminals	C-6	70	2.75
13		41865	41866	7613	Emergency Bldg. Lighting		6.0	8W	400	30	20	50	Screw Terminals	C-6	70	2.75
14		45101	45102	7613-1	Emergency Bldg. Lighting		6.0	8W	400	30	20	50	Slip-on Terminals	C-6	70	2.75
15		43561	43562	H7550	Halogen Hand Lantern	307	6.0	8W	25,000	3	3	50	Screw Terminals	C-6	70	2.75
16			23541	H7550-1	Halogen Hand Lantern	307	6.0	8W	25,000	3	3	50	Slip-on Terminals	C-6	70	2.75
17		43564	43565	H7551	Halogen Emergency Bldg. Lighting	307	6.0	8W	550	30	20	50	Screw Terminals	C-6	70	2.75
18		43567		H7552	Halogen Emergency Bldg. Lighting	307	6.0	10W	650	30	20	50	Screw Terminals	C-6	70	2.75
19		43570	43571	H7553	Halogen Emergency Bldg. Lighting	307	6.0	12W	850	30	20	50	Screw Terminals	C-6	70	2.75
20			43574	H7554	Halogen Emergency Bldg. Lighting	307	6.0	20W	1,400	30	20	50	Screw Terminals	C-6	70	2.75
21		24663	24661	4511	Tractor		6.2	30W	2,300	Trapezoidal		300 ⁽²⁴⁾	Screw Terminals	C-6	70	2.75
22		24678		4516	Spotlamp		6.2	30W	45,000	9	4	300	Screw Terminals	C-6	70	2.75
23		39585	39586	4042	Emergency Bldg. Lighting		6.4	12W	1,100	45	20	150	Screw Terminals	C-6	70	2.75
24		24339		4014	Emergency Bldg. Lighting		6.4	18W	1,500	50	25	200	Screw Terminals	C-6	70	2.75
25		24654	24653	4510	Tractor Flood, Emergency Bldg. Lighting		6.4	25W	800	80	20	300	Screw Terminals	C-6	70	2.75
26		24673	24671	4515	Spotlamp		6.4	30W	55,000	5	5	100	Screw Terminals	C-6	70	2.75
27		15133		H4515	Spotlamp, Shielded Bulb	307	6.4	30W	67,000	5.5	4	100	Screw Terminals	C-6	70	2.75
28		44642	44643	H7555	Halogen Emergency Bldg. Lighting	307	12.0	8W	550	30	20	50	Screw Terminals	C-6	70	2.75
29		40588	40589	4044	Emergency Bldg. Lighting		12.0	12W	1,100	50	25	150	Screw Terminals	C-6	70	2.75
30		10540	10541	4044-1	Emergency Bldg. Lighting		12.0	12W	1,100	50	25	150	Slip-on Terminals	C-6	70	2.75
31		12720	12721	H7557	Emergency Bldg. Lighting Halogen - Cycle	307	12.0	12W	850	30	20	50	Screw Terminals	C-6	70	2.75

4. At 14 volts.

23. At 7 volts.

109. Special fixture required for highway use.

301. See page 50.

307. See page 50.

SEALED BEAM LAMP SPECIFICATIONS

Line No.	Order Code			GE Lamp No.	Primary Application	Safety Notes	Design Vols	Design Watts or Amps	Approx. Initial Max. Beam C.P.	Approx. Total Spread to 10% Max. C.P. - Degrees		Rated Average Lab Life (Hours)	Base	Filament Designation	Max. Overall Length	
	Blister Pack	Unit Pack	Bulk Pack							Horiz.	Vert.				mm	(in.)
PAR36 BULB 114mm (4½ in) DIAMETER (continued)																
1		24478	24477	4414	Warning Signal, Emergency Bldg. Lighting, Garden and Security Lighting		12.8	18W	1,500	50	25	300	Screw Terminals	C-6	70	2.75
2		24487		4414R	Turn Signal, Warning Signal Red Lens		12.8	18W	275	50	25	300	Screw Terminals	C-6	70	2.75
3		39987	39988	7414Y	Signal, Light Yellow Lens		12.8	18W	1,000	50	25	300	Screw Terminals	C-6	70	2.75
4		37046	37047	4446	Emergency Bldg. Lighting		12.8	25W	400	80	80	300	Screw Terminals	C-6	70	2.75
5		24425	24423	4405	Spotlight		12.8	30W	50,000	6	5	100	Screw Terminals	C-6	70	2.75
6		22983	24503	4416	Spotlamp, Signal		12.8	30W	35,000	11	4	300	Screw Terminals	C-6	70	2.75
7			34901	4416-1	Spotlamp, Signal		12.8	30W	35,000	11	4	300	Slip-on Terminals	C-6	70	2.75
8		24506		4416A	Signal, Yellow Lens Cover		12.8	30W	26,000	11	4	300	Screw Terminals	C-6	70	2.75
9		24513		4416R	Signal, Red Lens Cover		12.8	30W	4,000	11	4	300	Screw Terminals	C-6	70	2.75
10		15129		H4405	Spotlamp, Shielded Bulb	307	12.8	30W	66,000	7	4	100	Screw Terminals	C-6	70	2.75
11		24430	24428	4406	Tractor, Flood		12.8	35W	600	80	30	300 ⁽⁴⁾	Screw Terminals	C-6	70	2.75
12		24439		4410	Backup Lamp, Tractor Flood		12.8	35W	600	80	30	300 ⁽⁴⁾	Screw Terminals	C-6	70	2.75
13		24448	24443	4411	Tractor		12.8	35W	3,000	Trapezoidal		300 ⁽⁴⁾	Screw Terminals	C-6	70	2.75
14		37889		4411-1	Tractor		12.8	35W	3,000	Trapezoidal		300 ⁽⁴⁾	Slip-on Terminals	C-6	70	2.75
15			48032	4411-3*	Tractor		12.8	35W	3,000	Trapezoidal		300 ⁽⁴⁾	Combination	C-6	70	2.75
16		22982		4415	Fog		12.8	35W	9,000	40	5	300	Screw Terminals	C-6	70	2.75
17		24499	24497	4415A	Fog, Yellow Lens		12.8	35W	7,000	40	5	300	Screw Terminals	C-6	70	2.75
18		24542		4422	Tractor		12.8	35W	600	75° Cone		300 ⁽⁴⁾	Screw Terminals	C-6	70	2.75
19		40190	40191	7400	Signal, Rotating Beacon		12.8	35W	33,000	12	5	300	Slip-on Terminals	C-6	70	2.75
20			42385	7400-1	Signal, Rotating Beacon		12.8	35W	33,000	12	5	300	Screw Terminals	C-6	70	2.75
21		42841	42842	H7600	Halogen Signal, Rotating Beacon	307	12.8	37.5W	60,000	9	4½	300	Screw Terminals	C-6	70	2.75
22		42838	42839	H7616	Halogen Spotlamp	307	12.8	37.5W	70,000	7	4	300	Screw Terminals	C-6	70	2.75
23		39932	39933	4440X	Tractor		12.8	40W	6,000	40	7	320 ⁽⁴⁾	3 Contact Lugs	C-6	76	3.00
							12.8	40W	4,500	33	9	320 ⁽⁴⁾		C-6		
24		39748		4440X-1	Tractor		12.8	40W	6,000	40	7	320 ⁽⁴⁾	3 Slip-on Terminals	C-6	70	2.75
							12.8	40W	4,500	33	9	320 ⁽⁴⁾		C-6		
25		40176		4460X	Tractor		12.8	40W	6,500	22	10	320 ⁽⁴⁾	3 Screw Terminals	C-6	70	2.75
							12.8	40W	5,000	22	13	320 ⁽⁴⁾		C-6		
26			17674	H4460X	Tractor	307	12.8	40W	11,000	22	10	320 ⁽⁴⁾	3 Screw Terminals	C-6	70	2.75
							12.8	40W	8,500	22	13	320 ⁽⁴⁾		C-6		
27		43576	43577	H7604	Halogen Spotlamp	307	12.8	50W	100,000	7	5	100	Screw Terminals	C-6	70	2.75
28		14616	43580	H7606	Tractor, Flood Halogen - Cycle	307	12.8	50W	1,000	80	30	400 ⁽⁴⁾	Screw Terminals	C-6	70	2.75
29		14618	43586	H7610	Halogen Tractor	307	12.8	50W	5,200	Trapezoidal		400 ⁽⁴⁾	Screw Terminals	C-6	70	2.75
30		49731	49732	H7614	Halogen Flood	307	12.8	50W	2,000	70	30	100	Screw Terminals	C-6	70	2.75
31		24592		4461	Tractor		12.8	60W	6,000	Trapezoidal		300 ⁽⁴⁾	Screw Terminals	C-6	70	2.75
32		24596		4466	Tractor		12.8	60W	1,000	80	30	300 ⁽⁴⁾	Screw Terminals	C-6	70	2.75
33			17672	H7607	Tractor Flood	307	12.8	65W	1,500	Non-Symmetrical		600 ⁽⁴⁾	Screw Terminals	C-6	70	2.75
34		24650	24649	4509	Aircraft Landing Spotlamp		13.0	100W	110,000	12	6	25	Screw Terminals	C-6	70	2.75
35		41503		4509X	Marine Spotlamp		13.0	100W	110,000	12	6	25	Screw Terminals	C-6	70	2.75
36		11444		4509Y	Special Service		13.0	100W	-	12	6	25	Screw Terminals	C-6	70	2.75
37		24690		4519	Marine		13.0	100W	30,000	40	7	25	Screw Terminals	C-6	70	2.75
38		39906	39907	4700	Spot/Flood		13.0	100W	100,000	12	7	25	3 Screw Terminals	C-6	70	2.75
							13.0	100W	50,000	17	18	25				
39		22109		Q4509	Halogen Quartzline®, Aircraft Landing	301	13.0	100W	140,000	7	7	100	Screw Terminal	C-8	70	2.75

4. At 14 volts.

301. See page 50.

307. See page 50.

SEALED BEAM LAMP SPECIFICATIONS

Line No.	Order Code			GE Lamp No.	Primary Application	Safety Notes	Design Volts	Design Watts or Amps	Approx. Initial Max. Beam C.P.	Approx. Total Spread to 10% Max. C.P. - Degrees		Rated Average Lab Life (Hours)	Base	Filament Designation	Max. Overall Length	
	Blister Pack	Unit Pack	Bulk Pack							Horiz.	Vert.				mm	(in.)
PAR36 BULB 114mm (4 1/2 in) DIAMETER (continued)																
1		25051		4313	Aircraft Landing	302	13.0	250W	140,000	16	7	25	Screw Terminals	C-6	70	2.75
2		34537		04631	Halogen Quartzline® Aircraft Landing, Wing Inspection	301	13.0	250W	80,000	13	12	500	Screw Terminals	C-6	70	2.75
3		39112		04632	Halogen Quartzline® Aircraft Logo	301	13.0	250W	75,000	14	12	500	Screw Terminals	C-6	70	2.75
4		12961		4402A	CIM Signal		28.0	50W	1,000	50	25	400	Screw Terminals	C-6	70	2.75
5		24627		4502	Auto Headlamp, Military		28.0	50W	10,000	40	7	400	Screw Terminals	C-6	70	2.75
6		24640	24638	4505	Aircraft Navigation		28.0	50W	45,000	11	5	400	Screw Terminals	CC-6	70	2.75
7		24873	24871	4589	Aircraft Cockpit Flood, C.I.M. Flood		28.0	50W	5,000	Trapezoidal		400	Screw Terminals	CC-6	70	2.75
8			23509	4589-1	Aircraft Cockpit Flood, C.I.M. Flood		28.0	50W	5,000	Trapezoidal		400	Slip-on Terminals	CC-6	70	2.75
9		24887		4593	Aircraft In-Air Refueling		28.0	50W	1,500	80	30	400	Screw Terminals	CC-6	70	2.75
10		24981	24982	4825R	C.I.M. Stop/Tail Red Lens		28.0	50W	200	-	-	200	3 Screw Terminals	C-2V	70	2.75
							28.0	18W	40	-	-	200		C-2V		
11		44724		4752	C.I.M. Flood		28.0	60W	2,000	50	25	800	Screw Terminals	2C-6	70	2.75
12		24882		4591	Aircraft Landing		28.0	100v	90,000	12	6	25	Screw Terminals	CC-6	70	2.75
13		24891		4594	Aircraft Navigation		28.0	100v	70,000	13	7	300	Screw Terminals	CC-6	70	2.75
14		24892		4595	Aircraft Navigation		28.0	100v	60,000	14	6	300	Screw Terminals	C-6	70	2.75
15		24966		4627	Aircraft Flood		28.0	100W	3,000	80	30	300	Screw Terminals	CC-6	70	2.75
16		24980		4811	Auto Headlamp, Military		28.0	110 W	Military/SAE Specifications			400	3 Contact Lugs	CC-6	76	3.00
							28.0	55W				400		CC-6		
17		24964		4626	Aircraft Taxiing		28.0	150v	25,000	40	9	300	Screw Terminals	CC-6	70	2.75
18		45427		4713	Aircraft Logo		28.0	150v	4,200	50	65	300	Screw Terminals	2C-6	70	2.75
19		24867		4587	Aircraft Taxiing	302	28.0	250W	40,000	40	13	25	Screw Terminals	CC-8	70	2.75
20		24898		4596	Aircraft Landing	302	28.0	250W	150,000	11	12	25	Screw Terminals	CC-8	70	2.75
21		39362	39363	4350	Electric Truck Work Light ¹⁵		36.0	60W	2,100	Trapezoidal		400	Slip-on Terminals	C-2V	70	2.75
22		39366	39367	4340	Electric Truck Work Light ¹⁵		48.0	80W	2,500	Trapezoidal		400	Slip-on Terminals	C-2V	70	2.75
PAR46 BULB 146mm (5 3/4 in) DIAMETER																
23		24369		4019	Tractor		6.2	30W	1,200	Trapezoidal		300 ²⁵	Screw Terminals	C-6	95	3.75
24		24327		4013	Tractor, Flood		6.4	25W	800	80	20	300	Screw Terminals	C-6	95	3.75
25		24735	24733	4535	Spotlamp		6.4	30W	95,000	5 1/2	4	100	Screw Terminals	C-6	95	3.75
26		24726		4531	Auto Headlamp, Military		12.5	40W	30,000	20	5	400	Screw Terminals	C-6	95	3.75
27		24577	24576	4435	Spotlamp		12.8	30W	75,000	5	5	100	Screw Terminals	C-6	95	3.75
28		24454	24453	4412	Fog		12.8	35W	11,000	40	7	300	Screw Terminals	C-6	95	3.75
29		24460	24459	4412A	Fog, Yellow		12.8	35W	8,800	40	7	300	Screw Terminals	C-6	95	3.75
30		22981	24464	4413	Tractor, Flood		12.8	35W	1,100	80	20	300 ¹⁹	Screw Terminals	C-6	95	3.75
31		24531	24525	4419	Tractor		12.8	35W	1,600	Trapezoidal		300 ¹⁹	Screw Terminals	C-6	95	3.75
32		24582		4436	Signal		12.8	35W	60,000	10	4	300	Screw Terminals	C-6	95	3.75
33		18523		H5006	Auto Headlamp, Low Beam Type 2C1	HI LO	12.8	35W	SAE Specifications			200 ¹⁹ 320 ¹⁹	3 Contact Lugs	C-6	102	4.00
34		18511		4000	Auto Headlamp, Low Beam Type 2C1	HI LO	12.8	37.5W 60W	SAE Specifications			200 ¹⁹ 320 ¹⁹	3 Contact Lugs	C-6	102	4.00
35		18516	24231	4001	Auto Headlamp, High Beam Type 1C1		12.8	37.5W	SAE Specifications			300 ¹⁹	2 Contact Lugs	C-6	102	4.00
36		38418		4040	Truck Headlamp, Low Beam Heavy Duty, Type 2C1	HI LO	12.8	37.5W 60W	SAE Specifications			300 ¹⁹ 500 ¹⁹	3 Contact Lugs	C-6	102	4.00
37		49695		H7612	Halogen Fog	307	12.8	37.5W	15,000	40	7	450	Screw Terminals	C-6	95	3.75
38		24572		4434A	School Bus Signal, Amber Lens		12.8	40W	1,000	55	25	100	Screw Terminals	C-6	95	3.75

4. At 14 volts.

301. See page 50.

15. This lamp is specially designed for a particular purchaser and may not be suitable for other uses because of its limited mechanical strength.

302. See page 50.

307. See page 50.

23. At 7 volts.

SEALED BEAM LAMP SPECIFICATIONS

Line No.	Order Code			GE Lamp No.	Primary Application	Safety Notes	Design Vols	Design Watts or Amps	Approx. Initial Max. Beam C.P.	Approx. Total Spread to 10% Max. C.P. - Degrees		Rated Average Lab Life (Hours)	Base	Filament Designation	Max. Overall Length	
	Blister Pack	Unit Pack	Bulk Pack							Horiz.	Vert.				mm	(in.)
PAR46 BULB 146mm (5⁷/₁₆ in) DIAMETER (continued)																
1		11639		5001*	Auto Headlamp, High Beam Type 1C1		12.8	50W	SAE Specifications		300 ⁽⁴⁾	2 Contact Lugs	C-6	102	4.00	
2		18922		H5001	Auto Headlamp High Beam, Type 1C1	307	12.8	50W	SAE Specifications		200 ⁽⁴⁾	2 Contact Lugs	C-6	102	4.00	
3		14617	43583	H7609	Halogen Tractor Flood	307	12.8	50W	2,200	80	20	400 ⁽⁴⁾	Screw Terminals	C-6	95	3.75
4		14619	43589	H7619	Halogen Tractor	307	12.8	50W	6,000	Trapezoidal		400 ⁽⁴⁾	Screw Terminals	C-6	95	3.75
5			45058	H7621-1	Halogen Auto/Truck Special Service ⁽¹⁰⁹⁾	307	12.8	50W	20,000	50	7	200 ⁽⁴⁾	Slip-on Terminals	C-6	95	3.75
6		43591	43592	H7635	Halogen Spotlamp	307	12.8	50W	160,000	6½	4	100	Screw Terminals	C-6	95	3.75
7			18022	H7635X	Halogen Spotlamp	307	12.8	50W	160,000	6½	4	100	Screw Terminals	C-6	95	3.75
8		24613		4478	C.I.M. Flood		13.0	60W	1,600	56	32	800 ⁽⁴⁾	2 Contact Lugs	2C-6	102	4.00
9		17894	17890	H7680HIR	Halogen Infrared Spotlamp	301	13.0	80W	275,000	6½	6½	100	Screw Terminals	C-8	95	3.75
10		26694	26695	H7680X HIR*	Halogen Infrared-Spotlamp Long Life	301	13.0	80W	230,000	6½	6½	300	Screw Terminals	C-8	95	3.75
11		24539	24541	4421	Auto/Truck, Special Service ⁽¹⁰⁹⁾		13.0	100W	23,000	50	7	300	Slip-on Terminals	C-6	95	3.75
12		24742		4537	Aircraft Landing		13.0	100W	200,000	11	6	25	Screw Terminals	C-6	80	3.13
13		40822	40823	4537-2	Spotlamp		13.0	100W	200,000	11	6	25	Screw Terminals	C-6	80	3.13
14		39022		4537X	Marine Spotlamp		13.0	100W	200,000	11	6	25	Screw Terminals	C-6	80	3.13
15		24700		4522	Aircraft Landing		13.0	250W	290,000	12	10	25 ⁽¹³⁸⁾	Screw Terminals	C-2 ⁽³²⁾	80	3.13
16		19632	16407	4636-3	Signal		14.0	80W	90,000	9	7½	200	Combination	2C-6	95	3.75
17		33284		4635	Aircraft Landing	302	16.5	450W	325,000	14	15	25	Screw Terminals	C-8	95	3.75
18		24721		4530	Signal, Flashing		26.0	5.3A	100,000	11	11	50	Screw Terminals	4CC-8	95	3.75
19		25005	25007	4578	C.I.M. Flood		28.0	60W	1,600	55	30	800	2 Contact Lugs	2C-6	102	4.00
20		24995		4880	C.I.M. Headlamp		28.0	60W	6,000	-	-	800	2 Contact Lugs	2C-6	102	4.00
21		25009	25011	4579	C.I.M. Headlamp		28.0	80W	24,000	25	25	400	3 Contact Lugs	CC-6	102	4.00
							28.0	60W	11,000	7	7	400		CC-6		
22		24828		4570	Aircraft Taxiing		28.0	150W	32,000	50	9	300	Screw Terminals	CC-6	95	3.75
23		24830		4571	Flood, Special Service		28.0	150W	7,000	80	25	300	Screw Terminals	CC-6	95	3.75
24		24833		4572	Auto Flood, Military		28.0	150W	4,500	55	55	300	Screw Terminals	CC-6	95	3.75
25		19628		4532	Aircraft		28.0	250W	75,000	12	19	100	Screw Terminals	CC-8	95	3.75
							28.0	150W	14,500	16	19	100		C2V		
26		24795		4551	Aircraft Taxiing		28.0	250W	75,000	50	10	25 ⁽¹³⁸⁾	Screw Terminals	CC-6	95	3.75
27		24799		4553	Aircraft Landing		28.0	250W	300,000	11	12	25 ⁽¹³⁸⁾	Screw Terminals	CC-8	80	3.13
28		41492		Q5551*	Halogen Quartzline®, Aircraft Taxiing	301	28.0	250W	60,000	48	12	100	Screw Terminals	CC-6	84	3.32
29		24802		4554	Aircraft Taxiing	302	28.0	450W	90,000	50	16	25	Screw Terminals	CC-8	80	3.13
30		24859		4580	Aircraft Landing	302	28.0	450W	400,000	13	14	10	Screw Terminals	CC-8	95	3.75
31		24862		4581	Aircraft Landing	302	28.0	450W	400,000	13	14	10	Screw Terminals	CC-8	80	3.13
32		24853		4582	Aircraft/Helicopter Flood	302	28.0	450W	20,000	50	55	10	Screw Terminals	CC-8	95	3.75
33		37706		Q4554	Halogen Quartzline®, Aircraft Taxiing	301	28.0	450W	65,000	50	11	100	Screw Terminals	CC-6	67	2.63
34		41097		Q4566	Halogen Quartzline®, Aircraft Logo Light	301	28.0	450W	150,000	16	12	1,000	Screw Terminals	CC-6	84	3.32
35		37372		Q4597	Halogen Quartzline®, Aircraft Flood	301	28.0	450W	16,000	60	35	1,000	Screw Terminals	CC-6	84	3.32
36		36271		Q4681	Halogen Quartzline®, Aircraft Landing	301	28.0	450W	310,000	15	9	50	Screw Terminals	CC-6	67	2.63

4. At 14 volts.

301. See page 50.

92. Filament segments parallel.

302. See page 50.

109. Special fixture required for highway use.

307. See page 50.

138. Life Test Conditions: Cycled 5 minutes on, 5 off.

SEALED BEAM LAMP SPECIFICATIONS

Line No.	Order Code			GE Lamp No.	Primary Application	Safety Notes	Design Volts	Design Watts or Amps	Approx. Initial Max. Beam C.P.	Approx. Total Spread to 10% Max. C.P. - Degrees		Rated Average Lab Life (Hours)	Base	Filament Designation	Max. Overall Length	
	Blister Pack	Unit Pack	Bulk Pack							Horiz.	Vert.				mm	(in.)
PAR56 BULB 178mm (7 in) DIAMETER																
1		25114		6006	Auto Headlamp	HI LO	6.1 6.2	50W 40W	SAE Specifications			300 500	3 Contact Lugs C-6	C-6	127	5.00
2		24768		4545	Marine Searchlight		12.0	100W	225,000	9	5	100	Screw Terminals	C-6	114	4.50
3		24764		4543	Marine Spotlight		12.5	100W	250,000	9	5	50	Screw Terminals	C-6	114	4.50
4		38416	38607	6015	Auto/Truck Headlamp, Heavy Duty, Type 2D1	HI LO	12.8 12.8	50W 50W	SAE Specifications			300 ⁽⁴⁾ 500 ⁽⁴⁾	3 Contact Lugs C-6	C-6	127	5.00
5		18519		6014	Auto Headlamp, Type 2D1	HI LO	12.8 12.8	60W 50W	SAE Specifications			320 ⁽⁴⁾ 150 ⁽⁴⁾	3 Contact Lugs C-6	C-6	127	5.00
6		19428	19559	H5024	Truck Headlamp, High/Low Beam, Type 2D1, Long Life	HI LO	12.8 12.8	65W 42W	SAE Specifications			400 ⁽⁴⁾ 2000 ⁽⁴⁾	3 Contact Lugs C-6	C-6	127	5.00
7		18525		H6024	Auto Headlamp, High/Low Beam, Type 2D1	HI LO	12.8 12.8	65W 35W	SAE Specifications			150 ⁽⁴⁾ 320 ⁽⁴⁾	3 Contact Lugs C-6	C-6	127	5.00
8		25153		6045	Signal		26.0	170W	230,000	9	8	100	Screw Terminals	CC-6	114	4.50
9		24973		4800	Auto Headlamp, Military		28.0	50W 40W	Military/SAE Specifications			400 400	3 Contact Lugs CC-6	CC-6	127	5.00
10		24756		4541	Aircraft Landing		28.0	450W	470,000	15	11	25	Screw Terminals	C-13	114	4.50
PAR64 BULB 203MM (8 in) DIAMETER																
11		40576		4552	Aircraft Landing		28.0	250W	500,000	7	8	25 ⁽¹³⁸⁾	Screw Terminals	CC-8	95	3.75
12		40578		4559	Aircraft Landing		28.0	600W	600,000	11	12	25 ⁽¹³⁸⁾	Screw Terminals	CC-8	95	3.75
13		40579		Q4599	Halogen Quartzline®, Aircraft Landing	301	28.0	600W	600,000	12	8	100 ⁽¹³⁸⁾	Screw Terminals	CC-6	95	3.75
14		42552		Q4599X	Halogen Quartzline®, Aircraft Landing	301	28.0	600W	765,000	11	7 1/2	100 ⁽¹³⁸⁾	Screw Terminals	CC-6	95	3.75
15		40577		Q4629	Halogen Quartzline®, Aircraft Logo Light	301	28.0	600W	20,000	55	35	1000	Screw Terminals	CC-6	122	4.81
16		16784		Q5599*	Halogen Quartzline®, Aircraft Landing	301	28.0	600W	650,000	11	7 1/2	200 ⁽¹³⁸⁾	Screw Terminals	CC-6	95	3.75
17		40581		4557	Aircraft Landing/Taxiing	302	28.0	1,000W 400W	540,000 100,000	11 25	15 11	25 100 ⁽¹³⁸⁾	3 Screw Terminals CC-6	CC-8	95	3.75
18		16152		5557	Aircraft Landing/Taxiing	302	28.0	1,000W 400W	540,000 100,000	11 25	15 11	50 100 ⁽¹³⁸⁾	3 Screw Terminals C-6	CC-8	95	3.75
19		40583		4555	Aircraft Landing	302	115.0	1,000W	600,000	20	11	25 ⁽¹³⁸⁾	Screw Terminals	C-13	95	3.75

4. At 14 volts.

138. Life Test Conditions: Cycled 5 minutes on, 5 off.

139. Life Test Conditions: Cycled 20 minutes on, 20 off.

301. See page 50.

302. See page 50.

307. See page 50.

SAFETY NOTES

301

▲ WARNING

Risk of fire

- Keep combustible materials away from lamp
- Use in fixture rated for this product

A damaged lamp emits UV radiation which may cause eye/skin injury

- Turn power off if glass bulb is broken. Remove and dispose of lamp.

Pressurized lamp—unexpected rupture may cause injury, fire, or property damage

- Use in enclosed fixture rated for this product
- Do not use lamp if outer glass is scratched or broken

▲ CAUTION

Risk of burn

- Allow lamp/fixture to cool before handling

Lamp may shatter and cause injury if broken

- Do not use lamp if outer glass is scratched or broken
- Dispose of lamp in a closed container

302

▲ WARNING

Risk of fire

- Keep combustible materials away from lamp
- Use in fixture rated for this product

Unexpected lamp rupture may cause injury, fire, or property damage

- Avoid contact with glass during operation
- Avoid direct water/liquid contact
- Use in enclosed fixture rated for this product

303

▲ WARNING

Lamp may shatter if used in wrong circuit

- Do not use in 110-120 Volt household circuit

304

▲ WARNING

Risk of fire

- Keep combustible materials away from lamp
- Use in fixture rated for this product

Lamp emits UV radiation which may cause eye/skin injury

- Avoid exposure of eyes and skin to unshielded lamp

Pressurized lamp—unexpected rupture may cause injury, fire, or property damage

- Use eye protection when handling lamp
- Do not exceed rated voltage
- Do not touch glass with bare hands
- Do not use lamp if outer glass is scratched or broken
- Dispose of lamp in a closed container
- Do not turn on lamp until fully installed
- Keep away from children
- Use protective screen when handling

▲ CAUTION

Risk of burn

- Allow lamp/fixture to cool before handling

FOR BEST PERFORMANCE

- Limit seal temperature to 350°C
- Maintain 250°C minimum bulb wall temperature
- Remove fingerprints from bulb with grease-free solvent
- Operate at design voltage

305

▲ CAUTION

Lamp may shatter and cause injury if broken

- Do not use excessive force when installing lamp

306

▲ WARNING

Pressurized lamp—unexpected rupture may cause injury, fire, or property damage

- Use eye protection when handling lamp
- Do not exceed rated voltage
- Avoid direct water/liquid contact
- Use in enclosed fixture rated for this product
- Do not use lamp if outer glass is scratched or broken
- Dispose of lamp in a closed container
- Do not turn on lamp until fully installed
- Keep away from children
- Use protective screen when handling

▲ CAUTION

Risk of burn

- Allow lamp/fixture to cool before handling

307

▲ WARNING

Pressurized lamp—unexpected rupture may cause injury, fire, or property damage

- Do not use lamp if outer glass is scratched or broken
- Dispose of lamp in a closed container

308

▲ WARNING

Risk of fire

- Keep combustible materials away from lamp
- Use in fixture rated for this product

Pressurized lamp—unexpected rupture may cause injury, fire, or property damage

- Use eye protection when handling lamp
- Do not exceed rated voltage
- Do not touch glass with bare hands
- Do not use lamp if outer glass is scratched or broken
- Dispose of lamp in a closed container
- Do not turn on lamp until fully installed
- Keep away from children
- Use protective screen when handling

▲ CAUTION

Risk of burn

- Allow lamp/fixture to cool before handling

FOR BEST PERFORMANCE

- Limit seal temperature to 350°C
- Maintain 250°C minimum bulb wall temperature
- Remove fingerprints from bulb with grease-free solvent
- Operate at design voltage

309

▲ WARNING

Risk of electric shock

- Turn power off before inspection, installation or removal

▲ CAUTION

Lamp may shatter and cause injury if broken

- Wear safety glasses and gloves when handling lamp
- Do not use excessive force when installing lamp

INFORMATION ON GE LAMPS – WORLDWIDE – IS AVAILABLE AT THE FOLLOWING LOCATIONS

ARGENTINA	GE Iluminacion S.A. Av. San Martin S/N Esquina 25 de Mayo 1618-EI Talar Tigre, Pcia de Buenos	Tel: (54) 11 4736 6600 Fax: (54) 11 4736 6616		ISRAEL	GE Hungary Tungsram Lighting 1340 Budapest Váci út 77	Tel: (36) 1 399 1100 Fax: (36) 1 399 1672
AUSTRALIA	GE Lighting Australia Ltd. 125-127 Long Street Smithfield, NSW 2164	Tel: (61) 2 9729 0011 Fax: (61) 2 9729 1144		JAPAN	GE Consumer Products Japan Ltd. 2nd Fl., Kowa 16 Building, South Wing, 9-20, Akasaka 1-chome Minato-ku, Tokyo 107-0052	Tel: (81) 3 5296 2960 Fax: (81) 3 5296 1500
AUSTRIA	GE Lighting GmbH Praunheimer Landstr. 50 60488 Frankfurt GERMANY	Tel: (49) 69 768 010 Fax: (49) 69 768 01 430		KAZAKHSTAN	GE Lighting Rep. Office Prime Business Centre 100, G.ul.Furmanova, 2nd Floor 480091 Almaty	Tel: (7) 3272 509 833, (7) 3272 509 834 Fax: (7) 3272 507 851
BAHRAIN, EGYPT, JORDAN, KUWAIT, OMAN, QATAR, SAUDI ARABIA, UAE, & YEMEN	GE International Operations Co., 54 Lebanon Street, Mohandessin Diza EGYPT	Tel: (20) 2 301 8060 or 8065 Fax: (20) 2 303 1082		KOREA	GE Samsung Lighting Co.Ltd. 3rd Floor Shinjungang B/D 646-9 Yoksam-Dong, Kangnam-Gu Seoul, Korea 135-911	Tel: (82) 2 569-4181 Fax: (82) 2 563-9933
BOTSWANA, NAMIBIA, SOUTH AFRICA, ZIMBABWE	GE Lighting South Africa 5 Bridget Road Benrose 2094 SOUTH AFRICA	Tel: (27) 11 618 3870/9 Fax: (27) 11 624 2485		MACEDONIA, SERBIA, MONTENEGRO & BIH	VSD MERKUR dooel Exclusive Agent of GE Hungary Rt. Kozle 88 B-3/7 1000 Skopje	Tel: (389) 2 391129 Fax: (389) 2 3917530
BRAZIL, URUGUAY	General Electric do Brasil Parque Industrial Thomas Edison Rua Miguel Angelo, 37 Maria da Graça Rio de Janeiro 20783-900 Brazil	Tel: (55) 21 582 6471 Fax: (55) 21 582 6533		MALAYSIA	General Electric International, Inc. Suit 3B-8-3 Block 3B Level 8, Plaza Sentral Jalan Stesen Sentral 5, Kuala Lumpur Sentral 50470 Kuala Lumpur.	Tel: (603) 2273-9788 Fax: (603) 2273-3473
BULGARIA	Representative Office of GE Hungary Tungsram Lighting 15 Zar Assen, 1st floor 1680 Sofia	Tel: (359) 2 9813492 Fax: (359) 2 9813492		MEXICO	GE Lighting Mexico, SA de CV Av. Churubusco No 3900 Norte Apartado Postal 216 64510 Monterrey, N.L. Mexico	Tel: (52) 8 318 5600 Fax: (52) 8 318 5693
CAMBODIA, LAOS, THAILAND, VIETNAM	GE Lighting (Thailand) Ltd. 191 Silom Complex Building 17th Floor Silom Road Bangrak Bangkok 10500 THAILAND	Tel: (66) 2 266 2621/5 Fax: (66) 2 266 2626		NEW ZEALAND	GE Lighting New Zealand Level 10, Lumley House 7 City Road Auckland	Tel: (64) 9 353 6706 Fax: (64) 9 353 6707
CARIBBEAN & CENTRAL AMERICA	General Electric Company 790 N.W. 107 Avenue, Suite 204 Miami, Florida 33172 USA	Tel: (1) 305 551 5114 Fax: (1)305 551 5116		NORWAY	GE Lighting AS Karenslyst Allé 2 0214 Oslo	Tel: (47) 23 28 21 00 Fax: (47) 23 28 21 09
CHILE / BOLIVIA	General Electric de Chile S/A Casilla 2103 Av. Vicuna Mackenna 2385 Santiago	Tel: (56) 2 555 3031 Fax: (56) 2 556 7329		PERU/ECUADOR	GE Lighting Peru Av. Garcilaso de la Vega 1420 Esquina Con Av. Espana Lima	Tel: (511) 433 9862 Fax: (511) 332 0482
CHINA	GE Lighting China Nan Zheng Building No. 580 West Nanjing Road Shanghai, 2000041	Tel: (86) 21 5234 1111 Fax: (86) 21 52341168		PHILIPPINES	GE Lighting Philippines 1873 P. Domingo Street 1207 Makati City, Metro Manila POB 2087 MCC	Tel: (632) 895 7051 Fax: (632) 890 8186
HONG KONG	GE International Operations Co.Inc. Room 801, The Lee Gardens 33 Hysan Avenue Causeway Bay Hong Kong	Tel: (852) 2100 6900 Fax: (852) 2376 0013		POLAND	General Electric Co. Polska Sp.z.o.o. Ul Jagiellonska 74 03-301 Warsaw	Tel: (48) 22 675 4466 Fax: (48) 22 814 1629
COLOMBIA	GE Lighting, Colombia Carrera 5 No. 81-50 Apto 204 El Pinar Alto Santafe de Bogota			PORTUGAL	GE Lighting Appliances España, s.a. Llull 95 - 97 Planta Baja 08005 Barcelona SPAIN	Freephone in Portugal: 800.836.010 Free fax in Portugal: 800.836.007
CROATIA	ADRIA LIGHTING Vila Tacen d.o.o. Exclusive agent of GE Hungary RT Lighting Business Tacenska 114a 1210 Ljubljana SLOVENIA	Tel: (386) 1 512 9245 Fax: (386) 1 530 4361		ROMANIA	GE Romania SRL Besta Center Str. Constantin Apostol nr. 10, etaj 4, Sector 6, Bucuresti	Tel: (40) 1 413 3328, 2247 Fax: (40) 1 413 5386
CYPRUS, GREECE, LEBANON, MALTA, SYRIA, EAST-WEST & NORTH AFRICA	GE Hungary Tungsram Lighting 1340 Budapest Váci út 77	Tel: (36) 1 399 1100 Fax: (36) 1 399 1672		RUSSIA	Representative Office of GE Hungary Tungsram Lighting Kosmodamianskaya nab.52 Building 1, 6th Floor Moscow 115054	Tel: (7) 095 935 7211 Fax: (7) 095 935 7279
CZECH REPUBLIC	GE Lighting spol. s.r.o. Lidicka 31 658 34 Brno	Tel: (420) 5 4132 1015, (420) 5 4132 1016 Fax: (420) 5 4132 1017		SINGAPORE, BRUNEI	GE Pacific Pte. Ltd. 240, Tanjong Pagar Rd. GE Tower #06-00 Singapore 088540 SINGAPORE	Tel: (65) 6326 3393 Fax: (65) 6326 3015
DENMARK	GE Lighting A/S Park Allé 295 DK-2605 Brøndby	Tel: (45) 43 42 44 51 Fax: (45) 43 42 44 52		SLOVAKIA	GE Lighting Tungsram RT Representative Office Cyrilometódska 38 94069 Nové Zámky	Tel: (421) 35 642 3075 Fax: (421) 35 642 3075
ESTONIA, LATVIA, LITHUANIA	Representative Office GE Hungary Tungsram Lighting Elizabetes 2 LV 1340 Riga LATVIA	Tel: (371) 7 321 710 Fax: (371) 7 321 762		SLOVENIA	ADRIA LIGHTING Vila Tacen d.o.o. Exclusive agent of GE Hungary RT Lighting Business Tacenska 114a 1210 Ljubljana	Tel: (386) 1 512 9245 Fax: (386) 1 530 4361
FINLAND	GE Lighting Oy Malmink kauppatie 18, 5 krs. FIN-00700 Helsinki	Tel: (358) 9 8560 6780 Fax: (358) 9 8560 6790		SPAIN	GE Lighting Appliances España, s.a. Llull 95 - 97 Planta Baja 08005 Barcelona	Freephone in Spain: 900 993.612 Free fax in Spain: 900 993.609
FRANCE & BENELUX	GE Lighting SARL ZAC Paris Nord II 13, rue de la Perdrix B.P. 50073 95947 Roissy CDG Cedex	Tel: (33) 1 48 63 68 00 Fax: (33) 1 48 63 68 08		SWEDEN	GE Lighting AB Box 306.Solna strandväg 98 171 75 STOCKHOLM	Tel: (46) 8 51 99 22 12 Fax: (46) 8 51 99 22 14
GERMANY	GE Lighting GmbH Praunheimer Landstr. 50 60488 Frankfurt	Tel: (49) 69 768 010 Fax: (49) 69 768 01 430		SWITZERLAND	GE Lighting GmbH Praunheimer Landstr. 50 60488 Frankfurt GERMANY	Tel: (49) 69 768 010 Fax: (49) 69 768 01 430
HUNGARY	GE Hungary Tungsram Lighting 1340 Budapest Váci út 77	Tel: (36) 1 399 1100 Fax: (36) 1 399 1672		TAIWAN	GE Lighting Taiwan 13th Floor, No. 168 Tun-Hwa North Road Taipei Taiwan, R.O.C.	Tel: (886) 2 2714 7000 Fax: (886) 2 2547 4568
INDIA	GE Lighting Ltd. H.R. Complex , 310/6 Industrial Main Road Koramangala 5th Block Bangalore 560 095	Tel: (91) 80 552 2023 Fax: (91) 80 552 2021		TURKEY	General Elektrik T.A.S. Kaskin Kalem Sk. No:5 80280 Esentepe/Istanbul	Tel: (90) 212 337 45 00 Fax: (90) 212 337 45 55
INDONESIA	GECP Indonesia BRI II, 27th Fl. Jend. Sudirman no. 44 -46 Jakarta 10210 Indonesia	Tel: (62) 21 574 5240 Fax: (62) 21 574 5241		UKRAINE	General Electric Co. Horizont Tower 42/44 Shovkovichna str., 8 Floor Kiev 01004	Tel: (380) 44 490 69 83 Fax: (380) 44 490 69 82
IRELAND	GE Lighting Ltd. 280 Holly Road Western Industrial Estate Naas Road Dublin 12	Tel: (353) 1 456 5591 Fax: (353) 1 450 4142		UNITED KINGDOM	GE Lighting Ltd. Lincoln Road Enfield Middlesex EN1 1SB	Tel: (44) 208 366 1166 Fax: (44) 208 727 4400
ITALY	GE Lighting Srl Via Astichello 2 36010 Vicenza	Tel: (39) 0444 391 311 Fax: (39) 0444 391 443		VENEZUELA	GE Iluminacion de Venezuela S.A. TERMAO Centro Banaven (Cubo Negro) Torre A Piso 6 Avenida La Estancia, Chuao Caracas, Venezuela	Tel: (58) 212 902 5131 Fax: (58) 212 902 5158
				VIETNAM	GE International, Inc. Suite 701, Central Building, 31 Hai Ba Trung Str Hanoi, Vietnam	Tel: 844 8251016 Fax: 844 8250551
				YUGOSLAVIA	VSD MERKUR dooel Exclusive Agent of GE Hungary Rt. Oton Zupancic 32b/9, 11000 Belgrade	Tel: (381) 11 3193741 Fax: (381) 11 3193741

GE LIGHTING DOMESTIC SALES OFFICES AND CONSUMER SERVICE CENTERS

GE LIGHTING HEADQUARTERS

CLEVELAND, OHIO Nela Park, Cleveland, OH 44112 (216) 266-2121

SALES OFFICES

To Obtain Sales Information Contact the closest Office

City	Address	Zip No.	Area Code	Phone No.
US SALES OFFICES				
ATLANTA, GA (South East)	5900 Windward Parkway, Suite 390 Alpharetta, GA	30005	(770)	753-3 83 Fax (770) 753-3 35
<i>NC, SC, TN, AR, LA, MS, AL, GA, FL</i>				
BOSTON, MA (Eastern)	980 Washington St, Suite 332 North Dedham, MA	02026	(781)	320-4252 Fax (781) 320-4270
<i>ME, NH, VT, NY, MA, CT, RI, NJ, DE, MD, VA</i>				
CHICAGO, IL (Midwest)	2021 Spring Road, Suite 500 Oak Brook, IL	60523-1 59	(630)	573-3500 Fax (630) 573-3916
<i>IN, IL, WI, MN, IA, NE, ND, SD</i>				
CLEVELAND, OH (North Central)	1975 Noble Road, Bld 335F Cleveland, OH	44112	(216)	266-8399 Fax (216) 266-5580
<i>PA, WV, KY, OH, MI</i>				
DALLAS, TX (Southwest)	6051 North State Highway, Suite 201 Irving, TX	75038	(972)	444-2048 Fax (972) 444-2061
<i>WY, CO, NM, TX, OK, KS, MO</i>				
IRVINE, CA (Pacific)	16257 Laguna Canyon Rd., Suite 100 Irvine, Ca.	92618	(949)	450-4700 Fax (949) 450-4712
<i>WA, OR, CA, MT, AK, HI, AZ, UT, ID, NV</i>				

CANADIAN OFFICES

CALGARY, ALBERTA	2728 Hopewell Place NE, Calgary, Alberta	T1Y 7J7	(403)	214-4435 Fax (403) 214-4772
MONTREAL, QUEBEC	555 St. Frederick-Philips Blvd 3rd FL, St. Laurent, Quebec	H4M 2X4	(514)	215-2740 Fax (514) 215-2795
OAKVILLE, ONTARIO	468 South Service Road East Oakville, Ontario	L6J 2X6	(905)	849-2911 Fax (905) 849-2911
VANCOUVER, BC	#100- 525 Baxter Place Burnaby, BC	V5A 4V7	(604)	451-3216 Fax (604) 451-3241

In addition to the Sales Offices in the cities listed above, GE Lamp Sales Representatives are resident in other cities. Consult your local telephone directory under GE Lighting.

FOR LAMP TECHNICAL SUPPORT CALL OR CLICK

1-800-GE LAMPS
WWW.GELIGHTING.COM

DEM AREA SALES OFFICES

Midwest	2021 Spring Road, Suite 550 Oak Brook, IL 60523-1859	(630) 573-3866	Fax (630) 573-3916
Southeast	1760 Moriah Woods Blvd, Suite 9 Memphis, TN 38117-712	(901) 762-4323	Fax (901) 762-4336
West	11600 Philadelphia St. Mira Loma, CA 91752	(949) 450-4767	Fax (909) 360-2421
Canada	468 South Service Road East Oakville, Ontario L6J 2X6	(905) 849-2039	Fax (905) 849-2911
Automotive	25900 Telegraph Rd. Southfield, MI 4 834	(248) 351-8031	Fax (248) 351-8069

US/CANADA CURRENT CUSTOMER ORDERING AND TRACKING- WWW.GELIGHTNET.COM

To Order Product	Telephone Number	Fax/Telex Number
CUSTOMER SERVICE CENTER		
DEM	1-800-544-4680	1-800-544-4830
AUTOMOTIVE DEM	1-800-327-7155	1-800-327-05 8
COMMERCIAL & INDUSTRIAL DISTRIBUTORS	1-800-327-0097	1-800-544-4830
CONSUMER & RETAIL	1-800-327-2080	1-800-544-4850
CANADA (French/English)	1-800-443-4925	1-800-443-4930
TELESALES		
DEM EAST	1-800-390-4944	1-800-327-0663
DEM WEST	1-800-544-4780	1-800-327-0663
C&I MIDWEST	1-800-624-0601	1-800-327-0663
C&I NORTH CENTRAL	1-800-390-4944	1-800-327-0663
C&I NORTHEAST	1-800-327-7085	1-800-327-0663
C&I PACIFIC	1-800-443-6272	1-800-327-0663
C&I SOUTHEAST	1-800-544-4610	1-800-327-0663
C&I SOUTHWEST	1-800-624-0601	1-800-327-0663
CANADA	1-800-443-5081	1-800-327-0663

DISTRIBUTION CENTERS

ATLANTA	1700 Westgate Parkway, Adena, GA 30336
CHICAGO	7770 West 71st Street, Bridgeview, IL 60455
DALLAS	1717 West Airfield Dr. PO Box 610847, FFW Airport, TX 75261
HAGERSTOWN	8212 Shawley Dr. Hagerstown, MD 21740
LOS ANGELES	11600 Philadelphia Ave., Mira Loma, CA 91752
OAKVILLE	1290 South Service Road West, Oakville, Ontario, Canada L6L 5T7
RAVENNA	150 Loomis Parkway, Ravenna, OH 44266

LIGHTING TECHNICAL INFORMATION

Consumer Inquiries	1-800-GE LIGHT (435-4448)
Commercial, Trade Magazines	1-800-GE LAMPS (435-2677)

INTERNATIONAL CUSTOMER SERVICE AND SALES (US EXPORTERS ONLY)

Franchise Exporters	1-800-327-6 6	FAX 1-800 443-5130
International Customers	1-804-965-1015	FAX 1-804 965-1018

All others contact the country sales office listed on the previous page.

FOR ORDERING AND TRACKING

WWW.GELIGHTNET.COM



GE Lighting

General Offices: Nela Park, Cleveland, Ohio 44112