

Heathkit®

Heathkit®

kit®

kit®

Heathkit®

Heathkit®

Heathkit®

Heathkit®

MOST ACCURATE CLOCK
Model GC-1000-H
595-4016-02

HEATH COMPANY PHONE DIRECTORY

The following telephone numbers are direct lines to the departments listed:

Kit orders and delivery information 616-982-3411
Credit 616-982-3561
Replacement Parts 616-982-3571

Technical Assistance Phone Numbers
(8:00 A.M. to 4:30 P.M. Eastern Time, Weekdays Only)

Education Products 616-982-3980
Amateur Radio 616-982-3296
Test Equipment, Weather Instruments,
Clocks 616-982-3315
Television 616-982-3307
Home Products, Stereo, Security, Telephone,
Marine, Automotive 616-982-3496
Computer — Hardware 616-982-3309

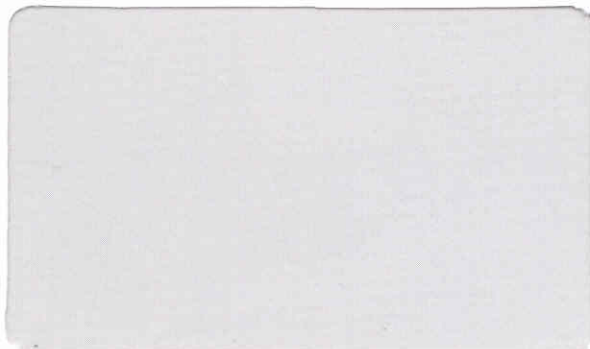

YOUR HEATHKIT 1 YEAR LIMITED WARRANTY

Consumer Protection Plan for Heathkit Consumer Products

Welcome to the Heath family. We believe you will enjoy assembling your kit and will be pleased with its performance. Please read this Consumer Protection Plan carefully. It is a "LIMITED WARRANTY" as defined in the U.S. Consumer Product Warranty and Federal Trade Commission Improvement Act. This warranty gives you specific legal rights, and you may also have other rights which vary from state to state.

Heath's Responsibility

PARTS — Replacements for factory defective parts will be supplied free for 1 year from date of purchase. Replacement parts are warranted for the remaining portion of the original warranty period. You can obtain warranty parts direct from Heath Company by writing or telephoning us at (616) 982-3571. And we will pay shipping charges to get those parts to you ... anywhere in the world.

SERVICE LABOR — For a period of 1 year from the date of purchase, any malfunction caused by defective parts or materials will be corrected at no charge to you. You must deliver the unit at your expense to the Heath factory, any Heath/Zenith Computers and Electronics center (units of Veritechnology Electronics Corporation), or any of our authorized overseas distributors.

TECHNICAL CONSULTATION — You will receive free consultation on any problem you might encounter in the assembly or use of our Heathkit product. Just drop us a line or give us a call. Sorry, we cannot accept collect calls.

NOT COVERED — The correction of assembly errors, adjustments, calibration, and damage due to misuse, abuse, or negligence are not covered by the warranty. Use of corrosive solder and/or the unauthorized modification of the product or of any furnished component will void this warranty in its entirety. This warranty does not include reimbursement for inconvenience, loss of use, customer assembly, set-up time, or unauthorized service.

This warranty covers only Heath products and is not extended to other equipment or components that a customer uses in conjunction with our products.

SUCH REPAIR AND REPLACEMENT SHALL BE THE SOLE REMEDY OF THE CUSTOMER AND THERE SHALL BE NO LIABILITY ON THE PART OF HEATH FOR ANY SPECIAL, INDIRECT, INCIDENTAL OR CONSEQUENTIAL DAMAGES, INCLUDING BUT NOT LIMITED TO ANY LOSS OF BUSINESS OR PROFITS, WHETHER OR NOT FORESEEABLE.

Some states do not allow the exclusion or limitation of incidental or consequential damages, so the above limitation or exclusion may not apply to you.

Owner's Responsibility

EFFECTIVE WARRANTY DATE — Warranty begins on the date of first consumer purchase. You must supply a copy of your proof of purchase when you request warranty service or parts.

ASSEMBLY — Before seeking warranty service, you should complete the assembly by carefully following the manual instructions. Heathkit service agencies cannot complete assembly and adjustments that are customer's responsibility.

ACCESSORY EQUIPMENT — Performance malfunctions involving other non-Heath accessory equipment (antennas, audio components, computer peripherals and software, etc.) are not covered by this warranty and are the owner's responsibility.

SHIPPING UNITS — Follow the packing instructions published in the assembly manuals. Damage due to inadequate packing cannot be repaired under warranty.

If you are not satisfied with our service (warranty or otherwise) or our products, write to our Director of Customer Service, Heath Company, Benton Harbor MI 49022. He will make certain your problems receive immediate, personal attention.

MOST ACCURATE CLOCK
Model GC-1000-H

595-4016-02

HEATH COMPANY
BENTON HARBOR, MICHIGAN 49022

Copyright © 1988
Heath Company
All Rights Reserved
Printed in Hong Kong

WARNING

Federal Communications Commission requirements prescribe verification of computing devices in Part 15 Subpart J of the rules and regulations. This computing device will meet these requirements when constructed in strict accordance with the instructions in this manual, using only components and materials supplied with the kit or the exact equivalent thereof.

This equipment has been verified to comply with the limits for a Class B computing device, pursuant to Subpart J of Part 15 of FCC Rules.

This equipment generates and uses radio frequency energy for its operation and if not installed and used properly, that is, in strict accordance with the instruction manual, may cause interference to radio and television reception. It has been type tested and found to comply with the RF emission limits for a Class B computing device which is intended to provide reasonable protection against such interference in a residential installation. However, there is no guarantee that interference will not occur in a particular installation. If this equipment does cause interference to radio or television reception, which can be determined by turning the equipment off and on, the user is encouraged to try to correct the interference by one or more of the following measures:

- Move the equipment away from the receiver being interfered with.
- Relocate the equipment with respect to the receiver.
- Reorient the receiving antenna.

Plug the equipment into a different AC outlet so that the equipment and receiver are on different branch circuits.

If you need additional help, consult the dealer or ask for assistance from the manufacturer. Customer service information may be found on the inside back cover of this manual or on an insert sheet supplied with this equipment. You may also find the following booklet helpful: "How to Identify and Resolve Radio-TV Interference Problems." This booklet is available from the US Government Printing Office, Washington, D.C. 20402 - Stock No. 004-000-00345-4.

WARNING: This instrument is not designed for outdoor use. To prevent fire or shock hazard, do not expose this instrument to rain or moisture.

TABLE OF CONTENTS

FCC Warning2	Final Assembly66
Introduction4	Theory of Operation68
Unpacking6	Operation	
Assembly Notes7	Operating Characteristics72
Display Circuit Board		Functions73
Parts List10	In Case of Difficulty76
Step By Step Assembly12	General77
Tone Decoder Circuit Board		Troubleshooting Chart78
Parts List21	Specifications80
Step By Step Assembly23	Circuit Description81
Main and Test Circuit Board		Circuit Board X-ray Views	
Parts List28 Illustration Booklet, Page 18	
Step By Step Assembly30	Semiconductor Identification Chart86
Cabinet		Receiver Circuit Board Replacement	
Parts List47	Parts List90
Step By Step Assembly49	Schematic	Fold-in
Initial Tests and Calibration		Warranty	Inside front cover
Primary Wiring Checks62	Customer Service	Inside rear cover
Calibration63		

INTRODUCTION

The Most Accurate Clock, Model GC-1000, utilizes circuitry which automatically synchronizes it with the National Bureau of Standards radio broadcast station, WWV.

The Clock has a preassembled, prealigned receiver which automatically switches for the best signal between the WWV channels at 5, 10, and 15 MHz. The Clock's time can be corrected for factors such as propagation delays, daylight-saving time, time zones, and UTC1. NOTE: For a more detailed description of these features, refer to the "Theory Of Operation" section of this Manual.

Other Clock features include:

- A 7-digit LED display which show hours through tenths of a second.
- A 12-hour or 24-hour format with AM and PM indicators for the 12-hour format.
- A local/UTC (Universal Coordinated Time) time switch.
- Any of 23 time zones selected via a dip switch.
- Corrections for WWV propagation delay in 1.25 ms (milliseconds) increments from 0 through 18.75 ms for up to 3600 miles from Ft. Collins, Colorado.
- Automatic switching for daylight-saving time.
- Selection of the UTC1 correction factor for "solar" time.
- Channel lockout in the event that interfering signals are present near a WWV channel.
- Automatic audio muting when WWV cannot be received.
- A volume control for adjusting the audible signal, with an "Off" position for manually muting the audio signal.
- A built-in telescoping antenna, and an antenna connector for an external antenna hookup.
- Operation from 120 VAC (or 220 VAC when wired accordingly), 50/60 Hz or with a 12 VDC power source.
- An on-board, crystal-controlled oscillator, trimmed by the microprocessor whose output is connected to a rear panel socket so it may be used as a reference signal.
- A microprocessor-controlled crystal oscillator whose frequency is automatically trimmed to within a few parts per minute (ppm).
- A "capture" LED indicator to indicate when WWV's signal is locked in.
- A "HiSpec" LED indicator to show that the clock is within the specified accuracy.

Heathkit®

- An LED indicator to show which of the three WWV channels is being received.
- A "data" LED indicator to show that the 100 Hz BCD (Binary Coded Decimal) information is being received.
- Easy modification for use with either WWV (Colorado) or WWVH (Hawaii).

The Clock can be used for both accurate time measurements and celestial navigation. There is also an optional RS-232C Output Accessory (Model GCA-1000-1) available for output to a computer.

The unit is housed in an attractive case which has a built-in speaker.

NOTICE: Since the GC-1000-H Most Accurate Clock depends on station WWV for its operation and accuracy, a good antenna is a necessity. If the signal conditions in your area are poor, you will find it necessary to construct an outdoor antenna before your GC-1000-H can operate properly. If possible, check with a local ham radio operator in your area to see what the signal conditions are, and what type of antenna you will need. You may also check with your local Heath Electronics Center for this information.

UNPACKING

Your kit is packed in one carton which contains Packs 1 to 3 and a final pack. A number of loose parts, some of which are wrapped, will be considered the "Final Pack" parts. A "Pack Index Sheet" is provided to show you the location of each Pack. You will be instructed to open each pack as it is needed. Do not remove any Packs or individual parts from the carton until they are specifically called for in a Parts List.

This Manual has a Parts List for each pack, with its own unpacking instructions which you should read carefully. The sections marked 1-3 on the "Pack Index Sheet" contain the parts for the circuit board assemblies. **It is very important to refer to the "pack index sheet" when the Manual instructs you to locate a certain pack.**

ASSEMBLY NOTES

TOOLS

You will need these tools to assemble your kit.

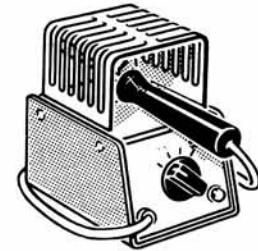
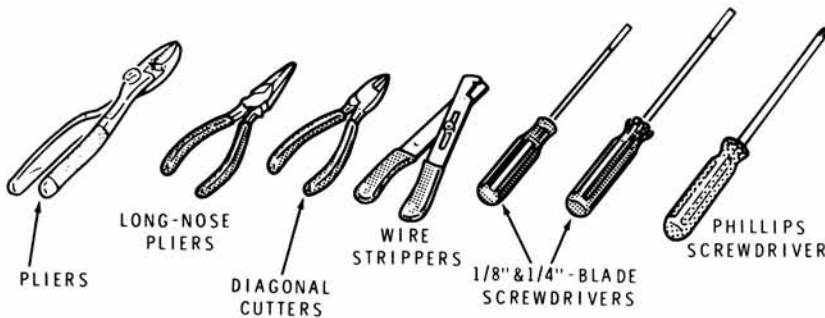

SOLDERING IRON

OR

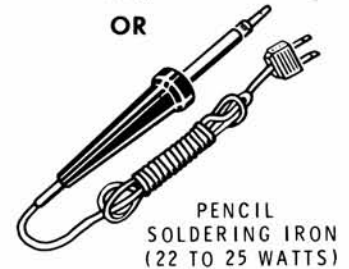

PENCIL SOLDERING IRON (22 TO 25 WATTS)

OTHER HELPFUL TOOLS

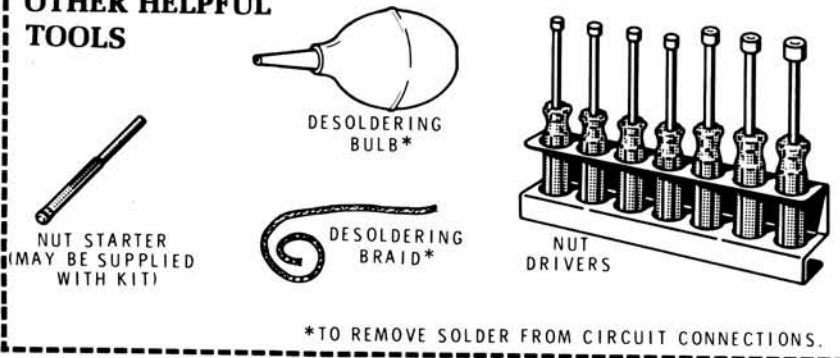

*TO REMOVE SOLDER FROM CIRCUIT CONNECTIONS.

ASSEMBLY

- Follow the instructions carefully. Read the entire step before you perform each operation.
- The illustrations in the Manual are called Pictorials and Details. Pictorials show the overall operation for a group of assembly steps; Details generally illustrate a single step. When you are directed to refer to a certain Pictorial "for the following steps," continue using that Pictorial until you are referred to another Pictorial for another group of steps.
- Most kits use a separate "Illustration Booklet" that contains illustrations (Pictorials, Details, etc.) that are too large for the Assembly Manual. Keep the "Illustration Booklet" with the Assembly Manual. The illustrations in it are arranged in Pictorial number sequence.
- Position all parts as shown in the Pictorials.
- Solder a part or a group of parts only when you are instructed to do so.

6. Each circuit part in an electronic kit has its own component number (R2, C4, etc.). Use these numbers when you want to identify the same part in the various sections of the Manual. These numbers, which are especially useful if a part has to be replaced, appear:
- In the Parts List,
 - At the beginning of each step where a component is installed,
 - In some illustrations,
 - In the Schematic,
 - In the section at the rear of the Manual.
7. When you are instructed to cut something to a particular length, use the scales (rulers) provided at the bottom of the Manual pages.

SAFETY WARNING: Avoid eye injury when you cut off excessive lead lengths. Hold the leads so they cannot fly toward your eyes.

SOLDERING

Soldering is one of the most important operations you will perform while assembling your kit. A good solder connection will form an electrical connection between two parts, such as a component lead and a circuit board foil. A bad solder connection could prevent an otherwise well-assembled kit from operating properly.

It is easy to make a good solder connection if you follow a few simple rules:

1. Use the right type of soldering iron. A 22 to 25-watt pencil soldering iron with a 1/8" or 3/16" chisel or pyramid tip works best.
2. Keep the soldering iron tip clean. Wipe it often on a wet sponge or cloth; then apply solder to the tip to give the entire tip a wet look. This process is called tinning, and it will protect the tip and enable you to make good connections. When solder tends to "ball" or does not stick to the tip, the tip needs to be cleaned and retinned.

NOTE: Always use rosin core, radio-type solder (60:40 tin-lead content) for all of the soldering in this kit. This is the type we have supplied with the parts. The Warranty will be void and we will not service any kit in which acid core solder or paste has been used.

RESISTORS

Resistors are identified in Parts Lists and steps by their resistance value in Ω (ohms), $k\Omega$ (kilohms), or $M\Omega$ (megohms). They are usually identified by a color code of four or five color bands, where each color represents a number. See the "Resistor Color Code" chart. These colors are given in the steps in their proper order (except for the last band, which indicates a resistor's "tolerance"; see the "Resistor Tolerance Chart"). You do not need to memorize the color codes.

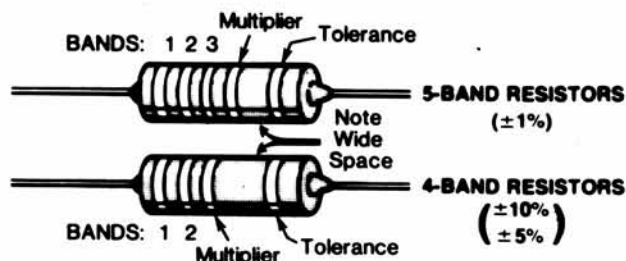

Occasionally, a "precision" or "power" resistor may have the value stamped on it. The letter R, K, or M may also be used at times to signify a decimal point, as in:

2R2 = 2.2 Ω
 2K2 = 2.2 $k\Omega$, or 2200 Ω
 2M2 = 2.2 $M\Omega$

Precision resistors may also be marked as shown in the following examples. The values of the multipliers are shown in the "Multiplier Chart," and the tolerance values are shown in the "Resistor Tolerance" chart.

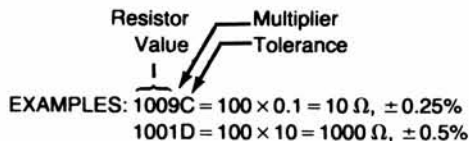

CAPACITORS

Capacitors will be called out by their capacitance value in μF (microfarads) or pF (picofarads) and type: ceramic, Mylar®, electrolytic, etc. Some capacitors may have their value printed in the following manner:

First and second digits of capacitor's value: 15

Multiplier: Multiply the first & second digits by the proper value from the "Multiplier Chart."

To find the tolerance of the capacitor, look up this letter in the capacitor Tolerance chart.

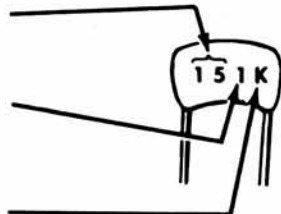

RESISTOR COLOR CODE CHART

	Band 1	Band 2	Band 3 (if used)	Multiplier
Color	1st Digit	2nd Digit	3rd Digit	
Black	0	0	0	1
Brown	1	1	1	10
Red	2	2	2	100
Orange	3	3	3	1,000
Yellow	4	4	4	10,000
Green	5	5	5	100,000
Blue	6	6	6	1,000,000
Violet	7	7	7	10,000,000
Gray	8	8	8	100,000,000
White	9	9	9	—
Silver	—	—	—	.01
Gold	—	—	—	.1

RESISTOR TOLERANCE CHART

	COLOR OR LETTER	
$\pm 10\%$	SILVER	
$\pm 5\%$	GOLD	J
$\pm 2\%$	RED	G
$\pm 1\%$	BROWN	F
$\pm 0.5\%$	GREEN	D
$\pm 0.25\%$	BLUE	C
$\pm 0.1\%$	VIOLET	B
$\pm 0.05\%$	GRAY	

MULTIPLIER CHART

FOR THE NUMBER:	MULTIPLY BY:	FOR THE NUMBER:	MULTIPLY BY:
0	1	4	10,000
1	10	5	100,000
2	100	8	0.01
3	1000	9	0.1

CAPACITOR TOLERANCE CHART

LETTER	10 pF OR LESS	OVER 10 pF
B	$\pm 0.1 \text{ pF}$	
C	$\pm 0.25 \text{ pF}$	
D	$\pm 0.5 \text{ pF}$	
F	$\pm 1.0 \text{ pF}$	$\pm 1\%$
G	$\pm 2.0 \text{ pF}$	$\pm 2\%$
H		$\pm 3\%$
J		$\pm 5\%$
K		$\pm 10\%$
M		$\pm 20\%$

EXAMPLES: 151K = $15 \times 10 = 150 \text{ pF}$
 759 = $75 \times 0.1 = 7.5 \text{ pF}$

NOTE: The letter "R" may be used at times to signify a decimal point, as in: 2R2 = 2.2 (pF or μF).

DISPLAY CIRCUIT BOARD

PARTS LIST

Refer to the Pack Index Sheet and locate Pack #1. Open the pack and check each part against this Parts List. The key numbers correspond with the numbers on the "Display Circuit Board Parts Pictorial" (Illustration Booklet, Page 1). Return any part that is in a small envelope back into the envelope after you have identified it, until that part is called for in a step. Do not throw away any packing material until you account for all the parts.

To order a replacement part, use the Parts Order Form furnished with this kit or refer to "Customer Service" inside the rear cover of this Manual.

KEY No.	HEATH Part No.	QTY.	DESCRIPTION	CIRCUIT Comp. No.
---------	----------------	------	-------------	-------------------

RESISTORS

NOTE: All resistors are 1/4-Watt, 5%, unless otherwise indicated.

A1	6-150	7	15 Ω, 1/2-Watt (brn-grn-blk)	R101 – R107
----	-------	---	------------------------------	-------------

Refer directly to "Display Circuit Board" on the enclosed resistor/diode sheet and follow the instructions at the top of that sheet to check the following resistors.

A1	6-220-12	1	22 Ω (red-red-blk)	R139
A1	6-221-12	5	220 Ω (red-red-brn)	R141 – R145
A1	6-102-12	7	1000 Ω (brn-blk-red)	R108, R109, R111 – R115
A1	6-103-12	7	10 kΩ (brn-blk-org)	R132 – R138
A1	6-333-12	4	33 kΩ (org-org-org)	R124 – R127
A1	6-473-12	10	47 kΩ (yel-viol-org)	R116 – R119, R121 – R123, R128, R129, R131

CAPACITORS

B1	27-77	1	.1 μF (104) Mylar	C101
B2	25-935	1	1000 μF electrolytic	C102

KEY No.	HEATH Part No.	QTY.	DESCRIPTION	CIRCUIT Comp. No.
---------	----------------	------	-------------	-------------------

TRANSISTORS — INTEGRATED CIRCUIT (IC)

NOTE: Transistors and integrated circuits are marked for identification in one of the following four ways:

1. Part number.
2. Type number. (On integrated circuits, use **only** those numbers and letters in **BOLD** print. Disregard any other numbers or letters.)
3. Part number and type number.
4. Part number with a type number other than the one listed.

C1	417-874	7	2N3906 transistor	Q101 – Q107
C1	417-801	14	MPSA20 transistor	Q108, Q109, Q111 – Q115, Q124 – Q129, Q131
C1	417-881	7	MPSA13 transistor	Q116 – Q119, Q121, Q122, Q123

CAUTION: The following integrated circuit can be easily damaged by static electricity. DO NOT remove this IC from its foam pad until you are instructed to do so in a step.

C2	443-931	1	MC14543 integrated circuit	U101
----	---------	---	----------------------------	------

Heathkit®

KEY No.	HEATH Part No.	QTY.	DESCRIPTION	CIRCUIT Comp. No.
---------	----------------	------	-------------	-------------------

LIGHT-EMITTING DIODES (LED)

D1	411-860	4	Large 7-segment (large)	V101 - V104
D2	411-864	3	Small 7-segment (smaller)	V105 - V107
D3	412-633	5	Red	D101, D102, D103, D106, D107
D3	412-641	1	Amber	D108
D3	412-642	2	Grqen	D104, D105

HARDWARE

E1	230-8290	2	M3 x 6 mm screw
E2	230-8438	2	M3 nut
E3	230-8440	2	M3 lockwasher

LABELS*

F1	390-1872	1	FCC
F2	390-2453	1	Function
F3	390-3423	1	Model

* Located inside the Manual. Set them aside after you check them.

KEY No.	HEATH Part No.	QTY.	DESCRIPTION	CIRCUIT Comp. No.
---------	----------------	------	-------------	-------------------

MISCELLANEOUS

	85-3329-1	1	Display circuit board	
G1	204-2683	2	Angle bracket	
	346-1	1	Sleeving	
G2	434-298	7	14-pin IC socket	
G2	434-299	1	16-pin IC socket	
G3	432-947	1	25-pin connector	X101
G4	230-8469	1	Nut starter	
G5	490-111	1	IC puller	
G6	490-185	1	Desoldering braid	
G7	438-55	1	Polarizing pin	
	597-260	1	Parts Order Form	
		1	Resistor/Diode sheet	
		1	Manual (see Page 1 for Part Number)	
			Solder	

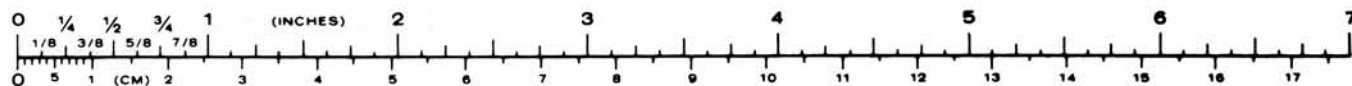

STEP-BY-STEP ASSEMBLY

START →

In the following steps, you will be told how to install and solder the first part on the circuit board. Read and perform each step carefully. Then use the same procedure whenever you install parts on a circuit board.

() Position the circuit board as shown with the printed side up. The side of the circuit board opposite the printed side will be referred to as the foil side.

() Locate R137, a 10 k Ω (brn-blk-org) resistor on the "Display Circuit Board" resistor strip and clip its leads close to the tape.

() Hold the resistor lead with long-nose pliers close to the body of the resistor. Then bend the leads straight down to fit the hole spacing in the circuit board.

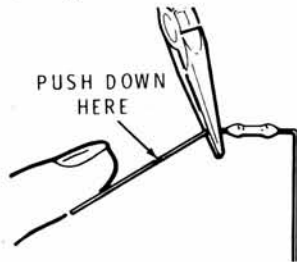

() R137: Push the leads through the holes at the indicated location on the circuit board. The end with color bands may be positioned either way.

() Press the resistor against the circuit board. Then bend the leads outward slightly to hold the resistor in place.

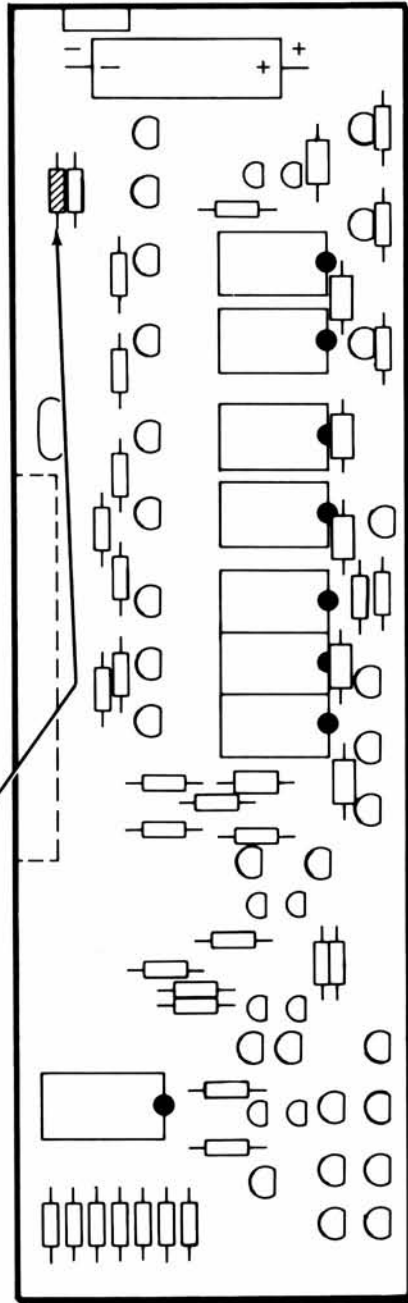

PICTORIAL 1-1

CONTINUE ⇐

() Solder the resistor leads to the circuit board as follows:

1. Push the soldering iron tip against both the lead and the circuit board foil. Heat **both** for two or three seconds.

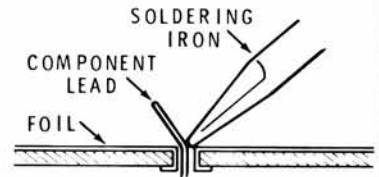

2. Then apply solder to the other side of the connection. **IMPORTANT:** Let the heated lead and the circuit board foil melt the solder.

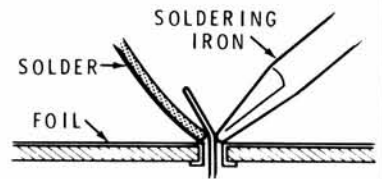

3. As the solder begins to melt, allow it to flow around the connection. Then remove the solder and the iron and let the connection cool.

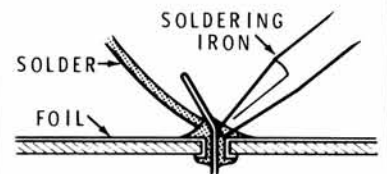

NOTE: Do not use too much solder. All the holes on this board are "plated through" holes and solder will flow onto the other side of the board. Use a minimum of solder and be careful not to fill nearby holes with solder.

() Cut off the excess lead lengths close to the connection. **WARNING:** Clip the leads so the ends will not fly toward your eyes.

() Check the connection. Compare it to the illustrations on Page 13. After you have checked the solder connections, proceed with the assembly on Page 14. Use the same soldering procedure for each connection.

A GOOD SOLDER CONNECTION

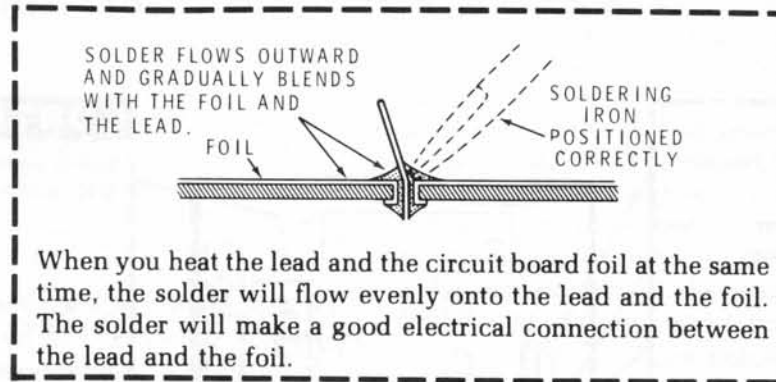

POOR SOLDER CONNECTIONS

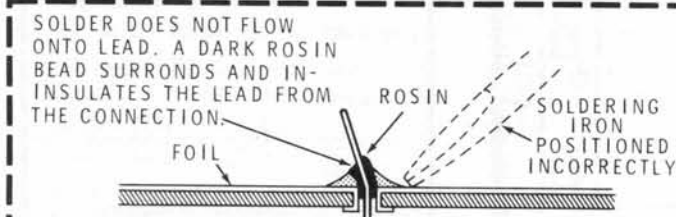

When the lead is not heated sufficiently, the solder will not flow onto the lead as shown above. To correct, reheat the connection and, if necessary, apply a small amount of additional solder to obtain a good connection.

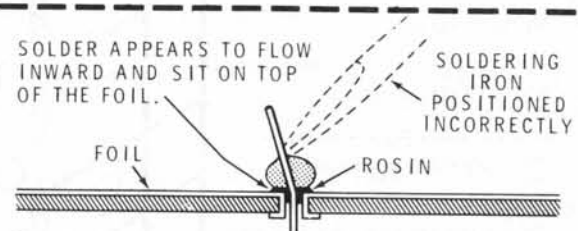

When the foil is not heated sufficiently the solder will blob on the circuit board as shown above. To correct, reheat the connection and, if necessary, apply a small amount of additional solder to obtain a good connection.

SOLDER BRIDGES

A solder bridge between two adjacent foils is shown in photograph A. Photograph B shows how the connection should appear. A solder bridge may occur if you accidentally touch an adjacent previously soldered connection, if you use too much solder, or if you "drag" the soldering iron across other foils as you remove it from the connection. A good rule to follow is: always take a good look at the foil area around each lead before you solder it. Then, when you solder the connection, make sure the solder remains in this area and does not bridge to another foil. This is especially important when the foils are small and close together. NOTE: It is alright for solder to bridge two connections on the same foil.

Use only enough solder to make a good connection, and lift the soldering iron straight up from the circuit board. If a solder bridge should develop, turn the circuit board foil-side-down and heat the solder between connections. The excess solder will run onto the tip of the soldering iron, and this will remove the solder bridge. NOTE: The foil side of most circuit boards has a coating on it called "solder resist." This is a protective insulation to help prevent solder bridges.

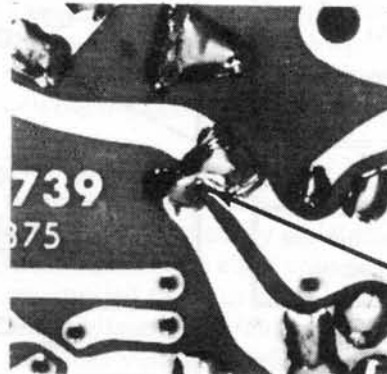

A

SOLDER BRIDGE



B

START ↘

NOTE: Make sure you installed the first part on Page 12 before you proceed.

- () R138: 10 kΩ (brn-blk-org).
- () R144: 220 Ω (red-red-brn).
- () R124: 33 kΩ (org-org-org).
- () R125: 33 kΩ (org-org-org).
- () R126: 33 kΩ (org-org-org).
- () R127: 33 kΩ (org-org-org).
- (✓) Solder the leads to the foil and cut off the excess lead lengths.
- () R128: 47 kΩ (yel-viol-org).
- (✓) R129: 47 kΩ (yel-viol-org).
- (✓) R131: 47 kΩ (yel-viol-org).
- () R139: 22 Ω (red-red-blk).
- () R141: 220 Ω (red-red-brn).
- () R142: 220 Ω (red-red-brn).
- () Solder the leads to the foil and cut off the excess lead lengths.

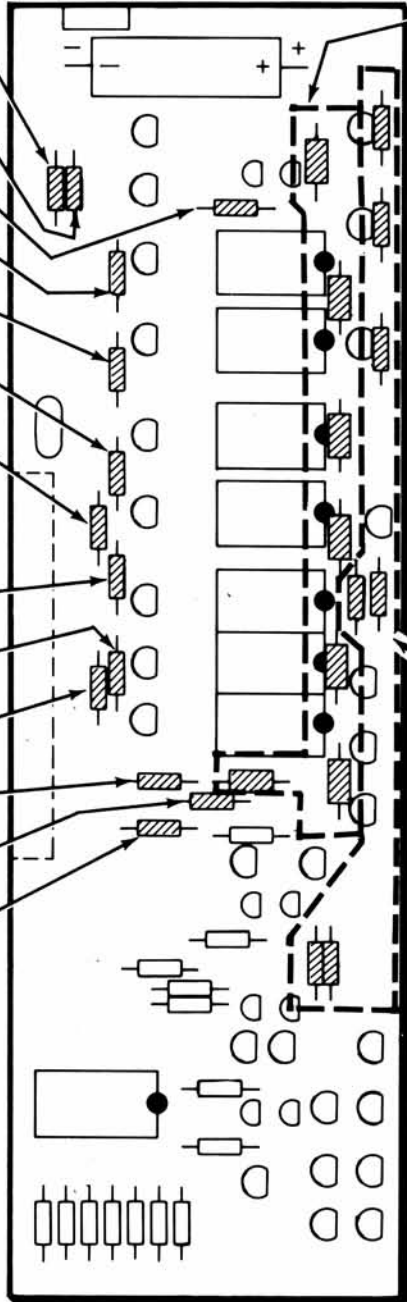

CONTINUE ↘

Install seven 15 Ω, 1/2-watt (brn-grn-blk) resistors as follows:

- () R101.
- () R102.
- () R103.
- () R104.
- () R105.
- () R106.
- () R107.
- (✓) Solder the leads to the foil and cut off the excess lead lengths.

Install seven 1000 Ω (brn-blk-red) resistors as follows:

- () R108.
- () R109.
- () R111.
- () R112.
- () R113.
- () R114.
- () R115.
- () Solder the leads to the foil and cut off the excess lead lengths.

PICTORIAL 1-2

CONTINUE

START

- () R132: 10 kΩ (brn-blk-org).
- () R135: 10 kΩ (brn-blk-org).
- () R143: 220 Ω (red-red-brn).
- () R133: 10 kΩ (brn-blk-org).
- () R145: 220 Ω (red-red-brn).
- () R136: 10 kΩ (brn-blk-org).
- () R134: 10 kΩ (brn-blk-org).
- () Solder the leads to the foil and cut off the excess lead lengths.
- Install seven 47 kΩ (yel-viol-org) resistors as follows:
- () R116:
- () R117:
- () R118:
- () R119:
- () R121:
- () R123:
- () R122:
- () Solder the leads to the foil and cut off the excess lead lengths.

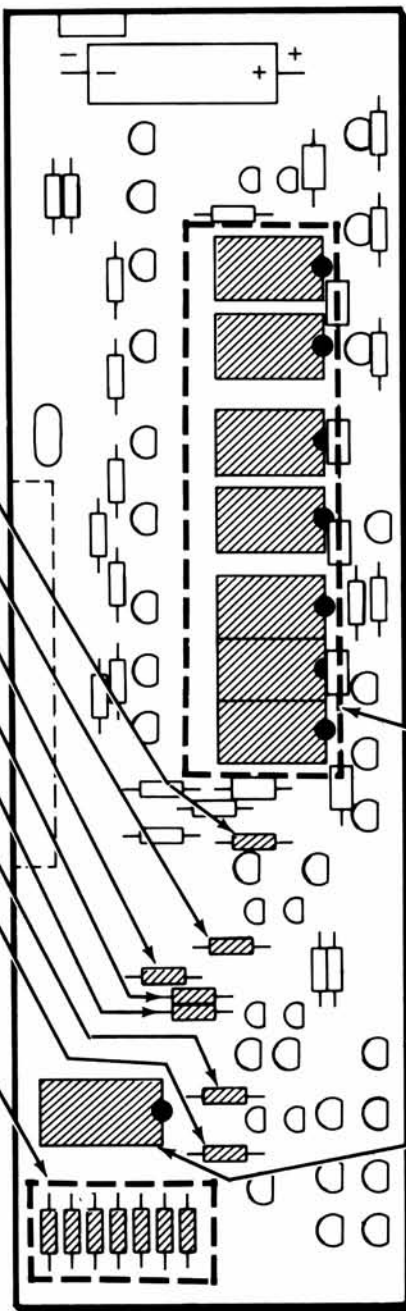

PICTORIAL 1-3

NOTE: Before you install an IC socket, make sure the pins are straight. If there is any kind of identification mark (notch, dot, arrowhead, etc.) at or near one end of the socket, place this marked end toward the index mark on the circuit board (this index mark should still be visible after you install the socket). Start the pins into the circuit board holes. Then turn the circuit board over, be sure there is a pin in each of the holes, and solder two diagonal corner pins to the foil. Check to make sure the IC socket is flat against the circuit board; then solder the remaining pins to the foil.

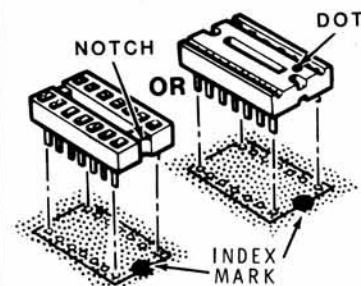

Install seven 14-pin IC sockets as follows:

- () V101.
- () V102.
- () V103.
- () V104.
- () V105.
- () V106.
- () V107.
- () U101: 16-pin IC socket.

() Check the foils for solder bridges. If a solder bridge has occurred, hold the circuit board foil-side-down as shown, and hold the soldering iron tip between the two points that are bridged. The solder will flow down the soldering iron tip.

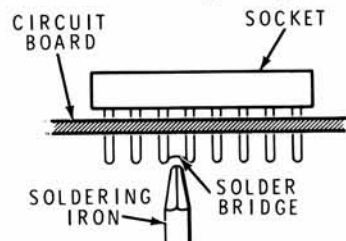

START ↘

NOTE: Before you install an electrolytic capacitor, look at it and identify the leads. Only one lead will have either a negative (-) mark or a positive (+) mark near it on the side of the capacitor. (The marking for a negative lead may look like an oblong bar, sometimes with a circle around it, inside an arrow.) . . . Be sure to install the negative lead in the negative-marked hole, and the positive lead in the positive-marked hole.

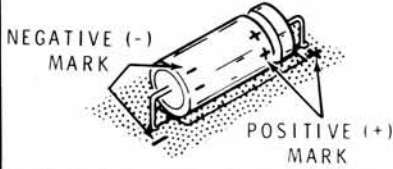

() C102: 1000 µF electrolytic.

NOTE: When you install each of the following transistors, position the flat on the transistor over the outline of the flat on the circuit board. Then insert the leads into the circuit board holes and space the transistor 3/16" from the circuit board. Solder the leads to the foil and cut off any excess lead lengths.

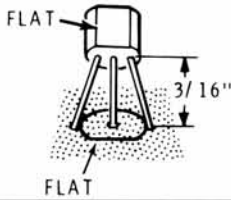

() Q131: MPSA20 transistor (#417-801).

() Q129: MPSA20 transistor (#417-801).

Install seven MPSA13 (#417-881) transistors as follows:

- () Q116
- () Q117
- () Q118
- () Q119
- () Q121
- () Q122
- (✓) Q123

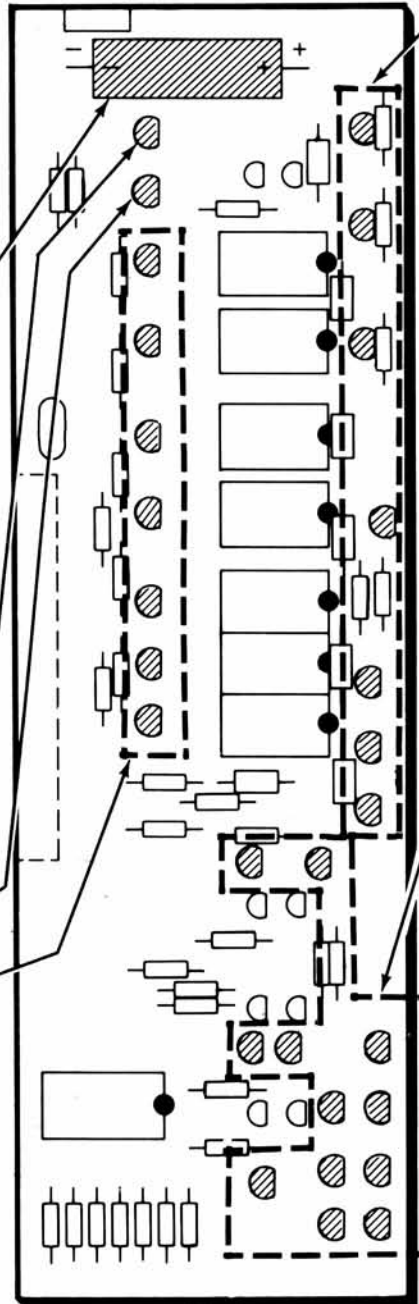

PICTORIAL 1-4

CONTINUE ↘

Install seven 2N3906 (#417-874) transistors as follows:

- () Q101.
- () Q102.
- () Q103.
- () Q104.
- (✓) Q105.
- () Q107.
- () Q106.

Install twelve MPSA20 (#417-801) transistors as follows:

- (✓) Q124.
- () Q127.
- () Q108.
- () Q125.
- () Q128.
- () Q111.
- () Q109.
- () Q113.
- (-) Q112.
- (-) Q114.
- (-) Q115.
- () Q126.

START

() C101: .1 μ F (104) Mylar. Solder the leads to the foil and cut off the excess lead lengths.

(/) Cut sixteen 3/8" pieces of sleeving. Save the remaining sleeving for later.

() Slide 3/8" pieces of sleeving over the leads of eight LEDs.

NOTE: When you install each of the following LEDs, position the **short** LED lead towards the flat outlined on the circuit board. Insert the leads into the circuit board holes until the black sleeving is against the circuit board. Solder the leads to the foil and cut off the excess lead lengths. **NOTE:** Make sure each LED is perpendicular to the circuit board and is not tipped before you solder it. Also, make sure all of the LEDs are the same height. **Reheat the leads to straighten tipped LEDs.**

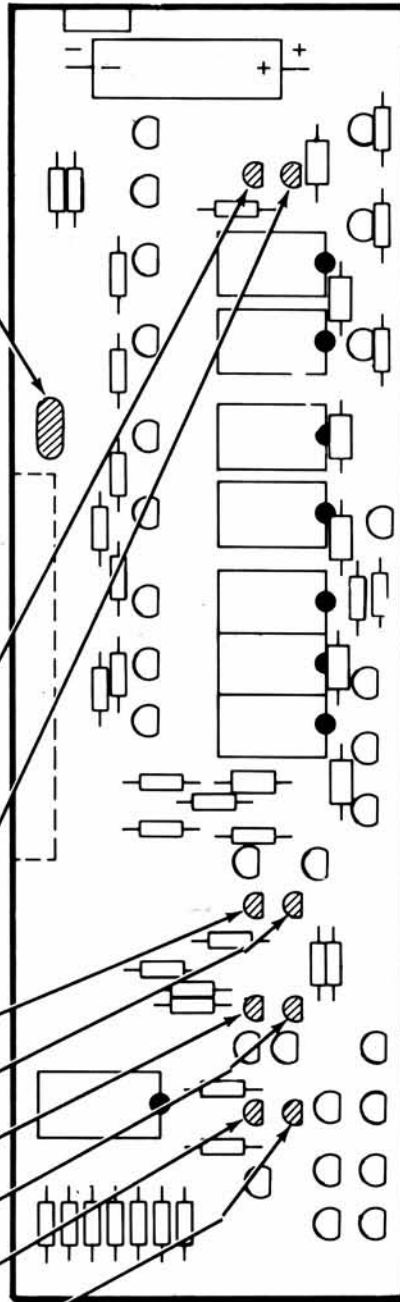
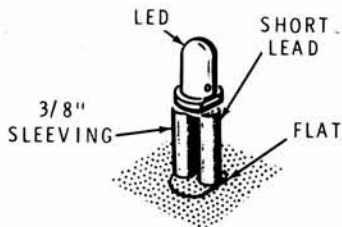

(/) D106: Red LED.

(/) D107: Red LED.

() D104: Green LED.

(/) D101: Red LED.

() D108: Amber LED.

() D102: Red LED.

() D105: Green LED.

(/) D103: Red LED.

PICTORIAL 1-5



START →

NOTE: When you install the large and small 7-segment LEDs in their sockets, check very carefully to make sure that all of the pins are straight and in line with each other. If you bend a pin over accidentally, you may break it off when you try to straighten it again. Position each LED with the decimals as shown with the pins started into their holes. Check to make sure they are going into the holes properly. Then push the LED the rest of the way into the socket.

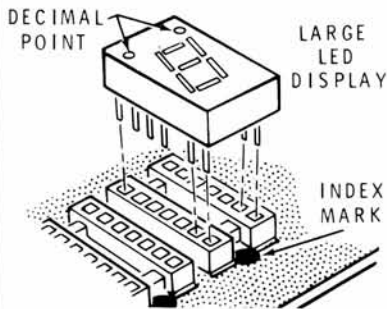

Install four large 7-segment LEDs (#411-860) into the IC sockets as follows:

- () V101
- () V102
- () V103
- () V104

Install three small 7-segment LEDs (#411-864) into the IC sockets as follows. Do not use the two holes at the ends of the socket.

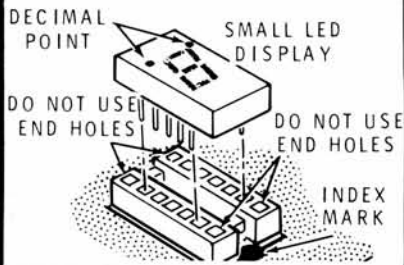

- () V105
- () V106
- () V107

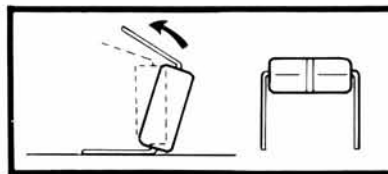

Detail 1-6A

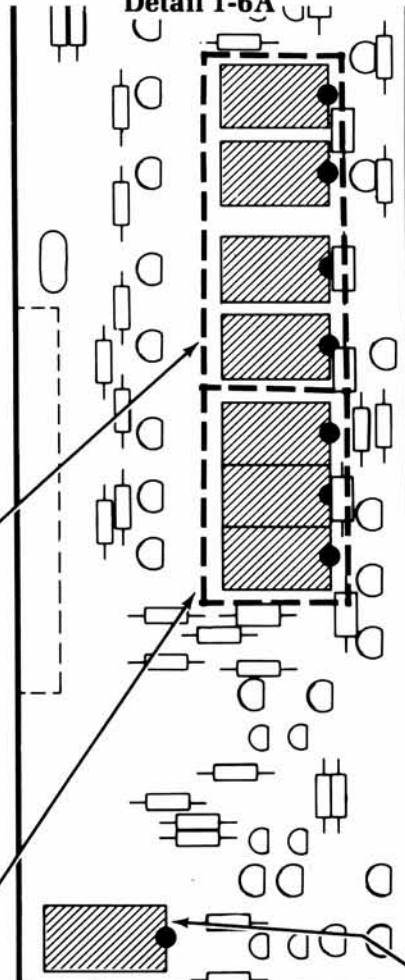

NOTE: The pin 1 end of inline integrated circuit may be marked in a number of ways; with a notch, triangle, dot, the number 1, etc.

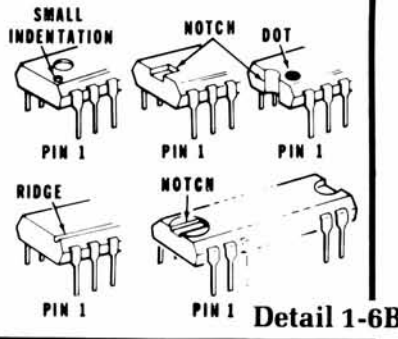

Detail 1-6B

PICTORIAL 1-6

CONTINUE →

CAUTION: When you install the following protected IC (mounted on a foam pad), be sure it does not get damaged by static electricity. Once you remove the foam pad, DO NOT let go of the IC. Install it as follows. Read the entire step before you pick up the IC.

1. Pick up the IC and touch the foam pad with both hands.
2. Hold the IC with one hand and remove the foam pad with the other hand.
3. Refer to Detail 1-6A and continue to hold the IC with one hand and roll the IC pins onto a flat surface to make sure they are parallel.
4. Pick up the circuit board in your other hand.
5. See Detail 1-6B and align the pin 1 end of the IC with the index mark on the circuit board.
6. Then push the IC pins into the IC socket. Once in the socket, the IC is protected.

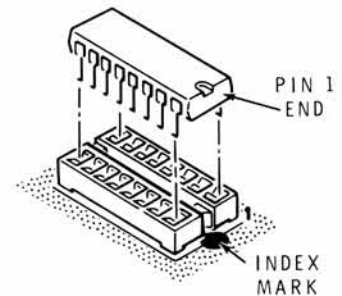

- () U101: MC14543 integrated circuit (#443-931).

Should it ever become necessary to remove an IC, use the IC puller. Insert the IC puller beneath the IC; then gently rock it back and forth to lift the IC.

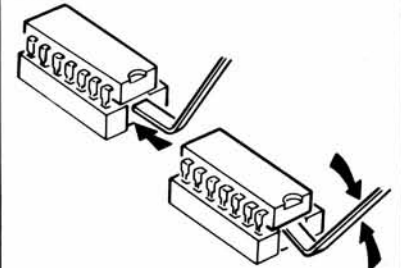

START →

() Turn the circuit board over so the foil side faces up for the next step only.

() X101: 25-pin connector. Position the connector over the edge of the circuit board. Then insert the pins into the circuit board and solder them to the component side foils.

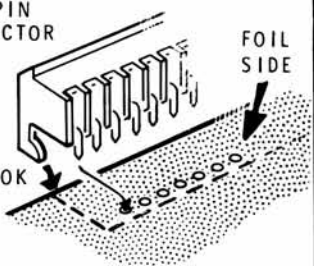

25-PIN CONNECTOR
HOOK
FOIL SIDE

() Press a polarizing pin into 25-pin connector hole 3 as shown on the circuit board. Disregard any numbers stamped on the connector.

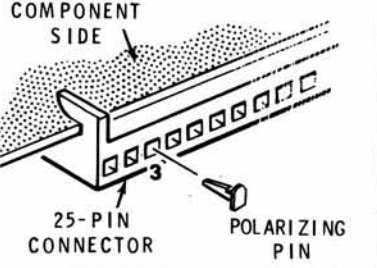

COMPONENT SIDE
25-PIN CONNECTOR
POLARIZING PIN

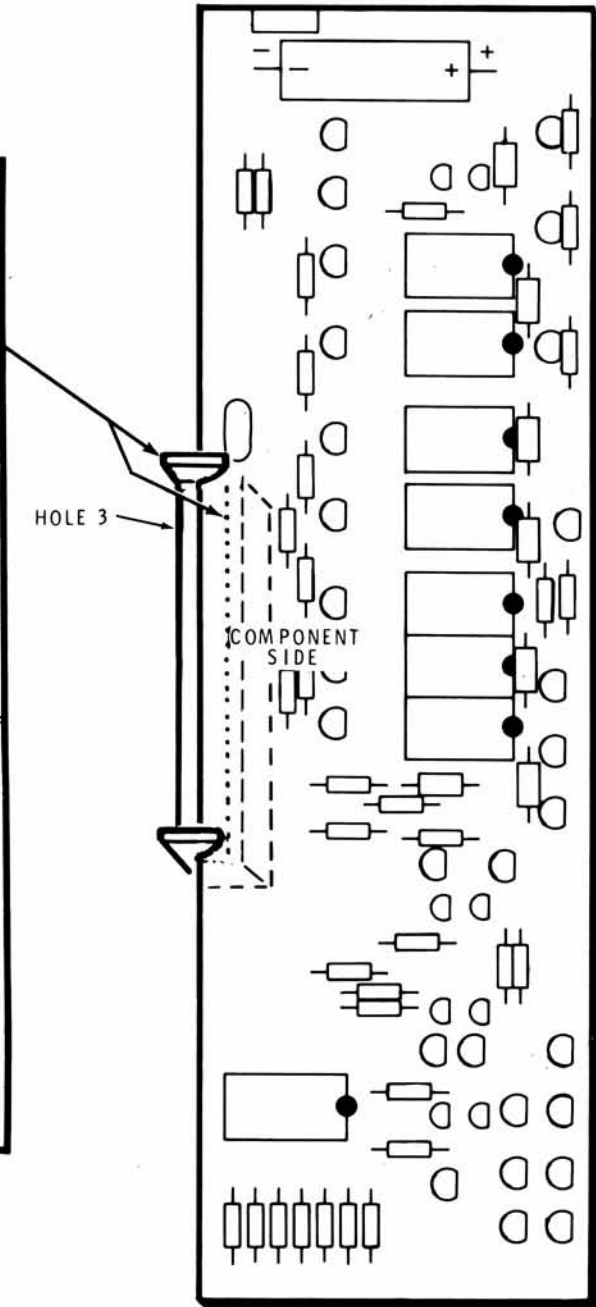

PICTORIAL 1-7

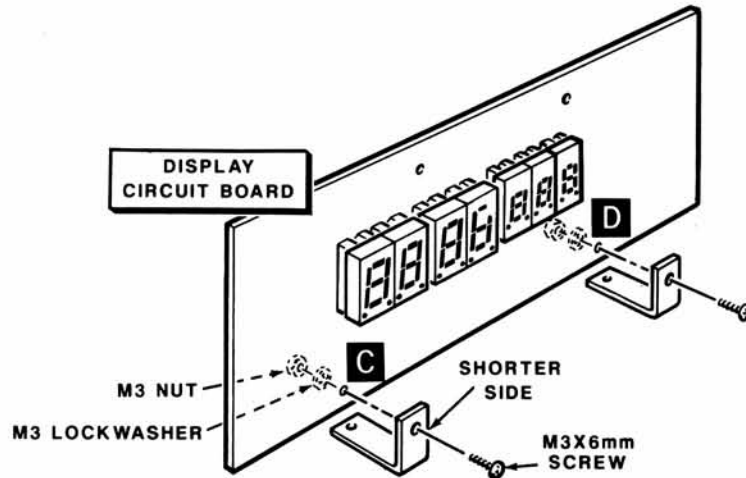

PICTORIAL 1-8

Refer to Pictorial 1-8 for the following steps.

- () Position the display circuit board as shown.

NOTE: Use the plastic nut starter to hold and start M3 and M3.5 nuts on screws.

- () Mount angle brackets at C and D with M3 × 6 mm screws, M3 lockwashers, and M3 nuts. Mount the shorter side of each bracket to the circuit board and position the brackets as shown.

CIRCUIT BOARD CHECKOUT

Carefully inspect the circuit board for the following conditions.

- () Unsoldered connections.
- () Poor solder connections.
- () Solder bridges between foil patterns.
- () Protruding leads which could touch together.
- () Transistors for the proper type and installation.
- () Electrolytic capacitor for the correct position of the positive (+) and negative (-) lead.
- () Integrated circuit and LEDs for the proper installation.

This completes the "Display Circuit Board Assembly." Set it aside until it is called for later.

TONE DECODER CIRCUIT BOARD

PARTS LIST

Remove the parts from Pack 2 and check each part against the following list. The key numbers correspond to the numbers on the "Tone Decoder Parts Pictorial" (Illustration Booklet, Page 2). Return any part that is in an individual envelope back into the envelope after you have identified it until that part is called for in a step. Do not throw away any packing material until you account for all the parts.

To order a replacement part, always include the PART NUMBER. Use the Parts Order Form furnished with this kit. If a Parts Order Form is not available, refer to "Replacement Parts" inside the rear cover of this Manual.

KEY No.	HEATH Part No.	QTY.	DESCRIPTION	CIRCUIT Comp. No.
---------	----------------	------	-------------	-------------------

RESISTORS

NOTE: All resistors are 1/4-watt.

Refer directly to "Tone Decoder Circuit Board" on the enclosed resistor/diode sheet to check your resistors and diodes.

1% Resistors

A1	6-1691-12	2	1690 Ω (brn-blu-wht-brn)	R426, R436
A1	6-7321-12	1	7320 Ω (viol-org-red-brn)	R443*
A1	6-9091-12	1	9090 Ω (wht-blk-wht-brn)	R443
A1	6-1302-12	1	13 kΩ (brn-org-blk-red)	R433
A1	6-4002-12	2	40 kΩ (yel-blk-blk-red)	R425, R435
A1	6-1583-12	2	158 kΩ (brn-grn-gry-org)	R427, R437

5% Resistors

A2	6-680-12	1	68 Ω (blu-gry-blk)	R451
A2	6-102-12	2	1000 Ω (brn-blk-red)	R424, R431

KEY No.	HEATH Part No.	QTY.	DESCRIPTION	CIRCUIT Comp. No.
---------	----------------	------	-------------	-------------------

A2	6-222-12	1	2200 Ω (red-red-red)	R441
A2	6-472-12	4	4700 Ω (yel-viol-red)	R429, R432, R439, R442
A2	6-223-12	1	22 kΩ (red-red-org)	R413
A2	6-273-12	3	27 kΩ (red-viol-org)	R419, R445, R448
A2	6-104-12	3	100 kΩ (brn-blk-yel)	R414, R422, R423
A2	6-124-12	1	120 kΩ (brn-red-yel)	R417
A2	6-224-12	2	220 kΩ (red-red-yel)	R412, R418
A2	6-274-12	1	270 kΩ (red-viol-yel)	R416
A2	6-334-12	2	330 kΩ (org-org-yel)	R428, R438
A2	6-474-12	2	470 kΩ (yel-viol-yel)	R415, R447
A2	6-684-12	1	680 kΩ (blu-gry-yel)	R449
A2	6-105-12	1	1 MΩ (brn-blk-grn)	R446

CONTROLS

B1	10-311	2	5000 (5K) Ω	R434, R444
----	--------	---	-------------	------------

*Part used for WWVH reception only.

KEY No.	HEATH Part No.	QTY.	DESCRIPTION	CIRCUIT Comp. No.
---------	----------------	------	-------------	-------------------

CAPACITORS**Mylar**

C1	27-212	2	.0082 μ F (822)	C415*, C416*
C1	27-161	4	.01 μ F (103)	C406, C415, C416, C417
C1	27-77	6	.1 μ F (104)	C407, C408, C409, C411, C418, C419
C2	27-217	1	.68 μ F (684)	C413

Electrolytic

C3	25-858	1	.33 μ F	C422
C3	25-900	1	1 μ F	C412
C4	25-221	2	2.2 μ F (2C2 or 2 μ 2 or 225) tantalum	C421, C425
C3	25-917	1	10 μ F	C414
C3	25-887	1	220 μ F	C424

SEMICONDUCTORS

D1	56-56	5	1N4149 diode	D402 - D406
----	-------	---	--------------	-------------

KEY No.	HEATH Part No.	QTY.	DESCRIPTION	CIRCUIT Comp. No.
---------	----------------	------	-------------	-------------------

NOTE: Transistors and integrated circuits may be marked for identification in any one of the following four ways:

1. Part number.
2. Type number. (On integrated circuits, use only those numbers and letters in BOLD print. Disregard any other numbers or letters.)
3. Part number and type number.
4. Part number with a type number other than the one shown.

D2	417-801	1	MPSA20 transistor	Q403
D3	442-71	1	LM3900 integrated circuit	U404
D3	442-688	2	NE567 integrated circuit	U402, U403

MISCELLANEOUS

	85-2868-1	1	Tone decoder circuit board	
F1	230-8467	2	Connector pin	
F2	432-947	1	25-pin connector	
F3	434-230	2	8-pin IC socket	
F3	434-298	1	14-pin IC socket	
F4	438-55	1	Polarizing pin	

*Parts used for WWVH reception only.

STEP-BY-STEP ASSEMBLY

START

(/) Position the tone decoder circuit board with the printed numbered and lettered side up.

NOTE: Remove the resistors from the "Tone Decoder Circuit Board" resistor strip for this section.

() R419: 27 kΩ (red-viol-org).

() R415: 470 kΩ (yel-viol-yel).

() R416: 270 kΩ (red-viol-yel).

() R417: 120 kΩ (brn-red-yel).

NOTE: When you install a diode, always match the band on the diode with the band mark on the circuit board. THE CIRCUIT WILL NOT WORK CORRECTLY IF A DIODE IS INSTALLED BACKWARDS. See Detail 2-1A.

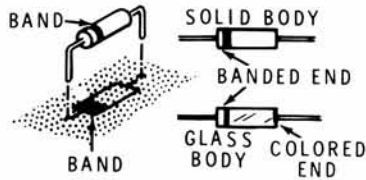

If your diode has a solid body, the band is clearly defined. If your diode has a glass body, do not mistake the colored end inside the diode for the banded end. Look for a band painted on the outside of the glass.

If your diode has color bands (yellow-black-yellow-white), the end that has a wide yellow band is the banded end.

Install four 1N4149 (#56-56) diodes as follows:

() D404.

() D406.

() D403.

() D402.

() Solder the leads to the foil and cut off the excess lead lengths.

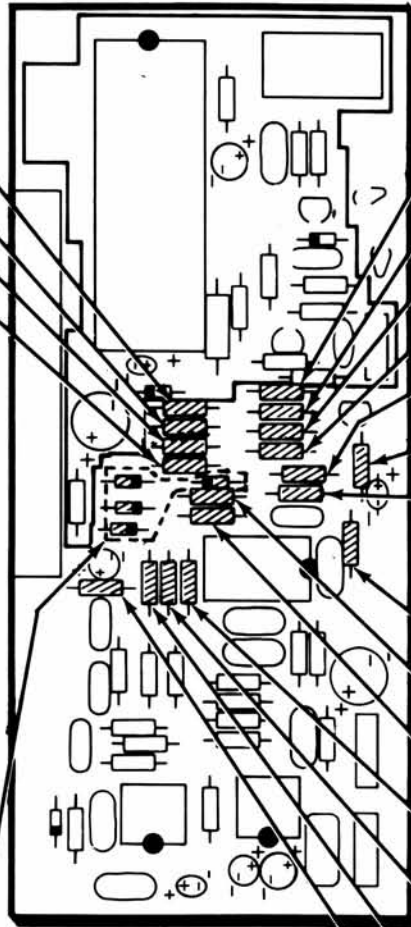

PICTORIAL 2-1

CONTINUE

(/) R418: 220 kΩ (red-red-yel).

(/) R448: 27 kΩ (red-viol-org).

() R449: 680 kΩ (blu-gry-yel).

() R422: 100 kΩ (brn-blk-yel).

(/) R445: 27 kΩ (red-viol-org).

(/) R447: 470 kΩ (yel-viol-yel).

(/) R412: 220 kΩ (red-red-yel).

() Solder the leads to the foil and cut off the excess lead lengths.

(/) R446: 1 MΩ (brn-blk-grn).

() R424: 1000 Ω (brn-blk-red).

() R423: 100 kΩ (brn-blk-yel).

() R414: 100 kΩ (brn-blk-yel).

(/) R425: 40 kΩ, 1% (yel-blk-blk-red).

(/) R435: 40 kΩ, 1% (yel-blk-blk-red).

() R413: 22 kΩ (red-red-org).

() Solder the leads to the foil and cut off the excess lead lengths.

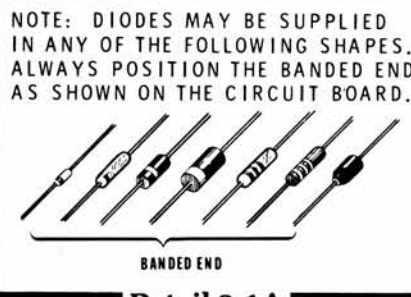

Detail 2-1A

START ↓

(/) R437: 158 kΩ, 1% (brn-grn-gry-org).

(/) R426: 1690 Ω, 1% (brn-blu-wht-brn).

(/) R436: 1690 Ω, 1% (brn-blu-wht-brn).

(/) R439: 4700 Ω (yel-viol-red).

(/) R441: 2200 Ω (red-red-red).

(/) Solder the leads to the foil and cut off the excess lead lengths.

(/) R442: 4700 Ω (yel-viol-red).

(/) R432: 4700 Ω (yel-viol-red).

(/) D405: 1N4149 diode (#56-56).

NOTE: You will assemble your Most Accurate Clock to receive either station WWV (Colorado) or WWVH (Hawaii). Determine which of these two stations you can receive; then install the appropriate resistor as follows.

For WWV:

(/) R443: 9090 Ω, 1% (wht-blk-wht-brn).

For WWVH:

(/) R443: 7320 Ω, 1% (viol-org-red-brn).

(/) Solder the leads to the foil and cut off the excess lead lengths.

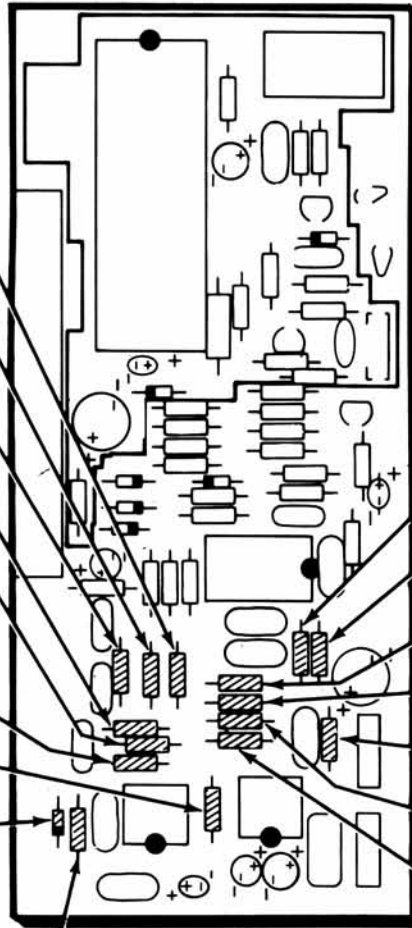
**PICTORIAL 2-2****CONTINUE** ↓

(/) R428: 330 kΩ (org-org-yel).

(/) R438: 330 kΩ (org-org-yel).

(/) R427: 158 kΩ, 1% (brn-grn-gry-org).

(/) R431: 1000 Ω (brn-blk-red).

(/) R451: 68 Ω (blu-gry-blk).

(/) R429: 4700 Ω (yel-viol-red).

(/) R433: 13 kΩ, 1% (brn-org-blk-red).

(/) Solder the leads to the foil and cut off the excess lead lengths.

START

() X401: Position the 25-pin connector over the edge of the circuit board on the **component** side and insert the pins into the holes. Solder the pins to the foil. Disregard any numbers stamped on the connector.

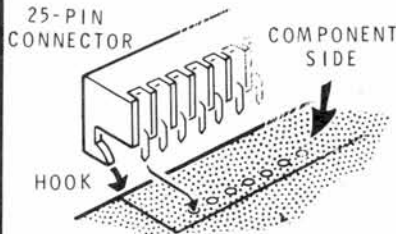

NOTE: Before you install an IC socket, make sure the pins are straight. If there is any kind of identification mark (notch, dot, arrowhead, etc.) at or near one end of the socket, place this marked end toward the index mark on the circuit board (this index mark should still be visible after you install the socket). Then start the pins into the circuit board holes and solder them to the foil.

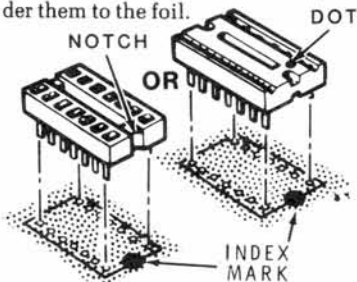

NOTE: It is very easy to form a solder bridge between foils on the circuit board. After each solder step, carefully inspect the foil for solder bridges and remove any that have formed.

If a solder bridge has occurred, hold the circuit board foil-side-down as shown, and hold the soldering iron tip between the points that are bridged. The solder will flow down the soldering iron tip.

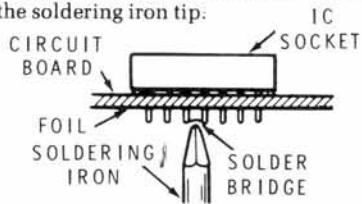

() U404: 14-pin IC socket.

() U403: 8-pin IC socket.

() U402: 8-pin IC socket.

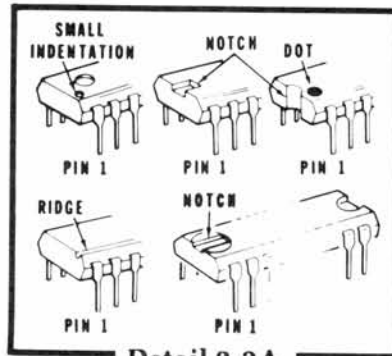

Detail 2-3A

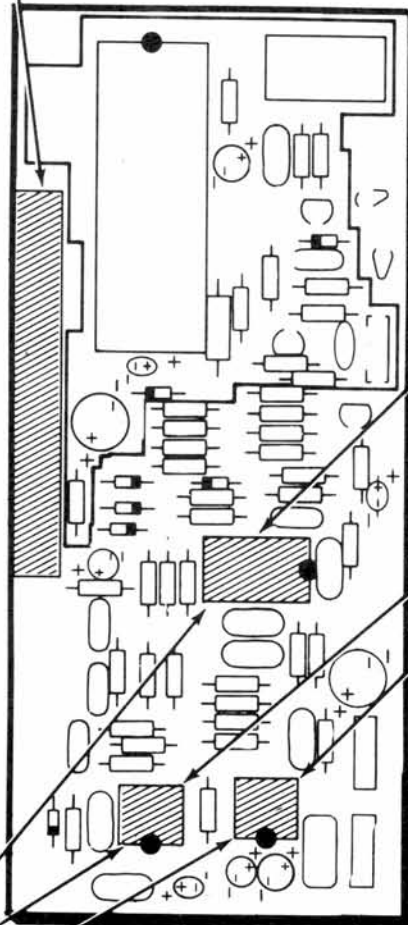

PICTORIAL 2-3

CONTINUE

Install each of the integrated circuit (ICs) as follows.

1. Be sure the ICs pins are straight. Then lay it down on one of its rows of pins, as shown at A, and roll it over until the pins are at right angles or bent in slightly as shown at B. Repeat this process for the other row of pins.

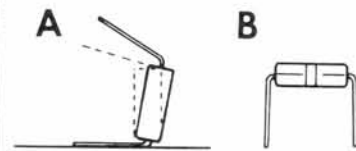

2. Pick up the circuit board in your other hand.
3. See Detail 2-3A and align the pin 1 end of the IC with the index mark on the circuit board.
4. Then push the IC pins into the IC socket.

() U404: LM3900N (#442-71) IC.

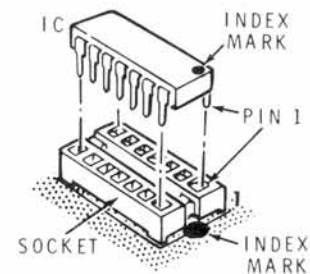

() U403: NE567 (#442-688) IC.

() U402: NE567 (#442-688) IC.

Should it ever become necessary to remove an IC, use the IC puller. Insert the IC puller beneath the IC; then gently rock it back and forth to lift the IC.

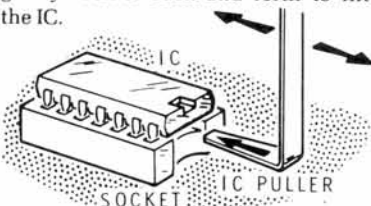

START

NOTE: When you install a connector pin, push as far as possible into the circuit board hole from the component side. Then solder the pin to the foil. Use solder sparingly to avoid filling the connector.

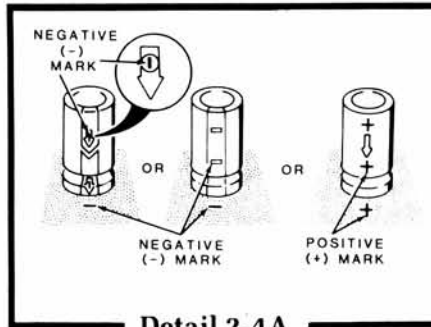
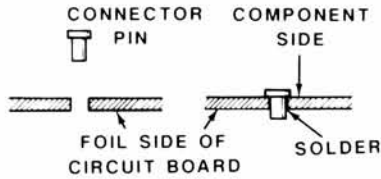

Detail 2-4A

(/) TP1: Connector pin.

() TP2: Connector pin.

NOTE: When you install the following transistor, line up the flat of the transistor with the outline of the flat on the circuit board. Insert the transistor leads into their correct holes. Solder the leads to the foil and cut off any excess lead lengths.

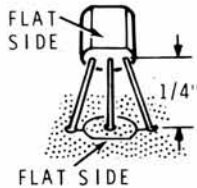

(/) Q403: MPSA20 transistor (#417-801).

() C406: .01 μ F (103) Mylar.

(/) C407: .1 μ F (104) Mylar.

NOTE: If you are assembling your Clock to receive WWV, perform the steps under that sector. If you intend to receive WWVH, perform those steps.

For WWV:

(/) C415: .01 μ F (103) Mylar.

() C416: .01 μ F (103) Mylar.

For WWVH:

() C415: .0082 μ F (822) Mylar.

() C416: .0082 μ F (822) Mylar.

(/) Solder the leads to the foil and cut off the excess lead lengths.

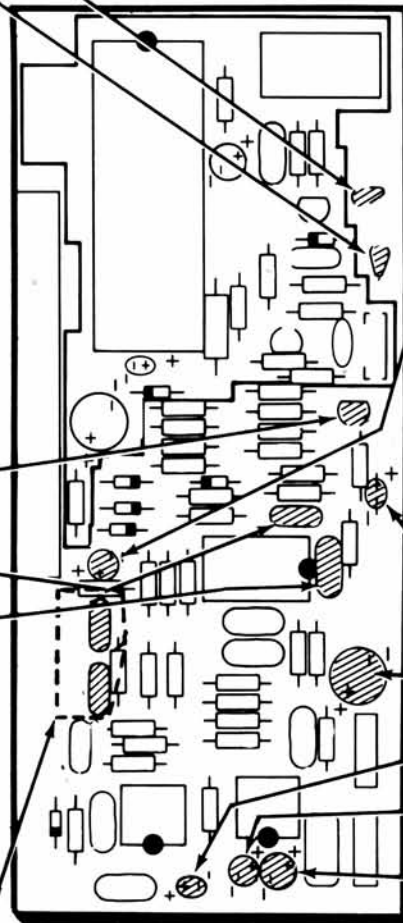

PICTORIAL 2-4

CONTINUE

NOTE: Before you install a polarized electrolytic capacitor, look at it and identify the leads. One lead will have a positive (+) mark or a negative (-) mark near it. **Be sure** to install the positive lead in the positive-marked hole and the negative lead in the negative-marked hole. Be careful; only the negative lead may be marked. See Detail 2-4A.

() C422: .33 μ F electrolytic.

NOTE: When you install a tantalum capacitor, always match the positive (+) or color dot on the capacitor with the positive (+) mark on the circuit board.

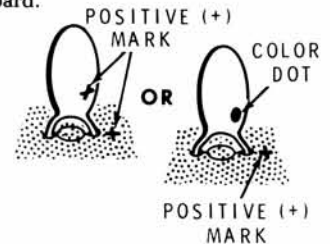

() C425: 2.2 μ F (2C2 or 2 μ 2 or 225) tantalum.

() C424: 220 μ F electrolytic.

(/) C421: 2.2 μ F (2C2 or 2 μ 2 or 225) tantalum.

() C412: 1 μ F electrolytic.

() C414: 10 μ F electrolytic.

(/) Solder the leads to the foil and cut off the excess lead lengths.

START

- C409: .1 μ F (104) Mylar.
- C408: .1 μ F (104) Mylar.
- C411: .1 μ F (104) Mylar.
- C413: .68 μ F (684) Mylar. NOTE: You may have to form the leads of this capacitor to fit the circuit board holes.
- C417: .01 μ F (103) Mylar.
- C419: .1 μ F (104) Mylar.
- C418: .1 μ F (104) Mylar.
- Solder the leads to the foil and cut off the excess lead lengths.
- R444: 5000 (5K) Ω control (#10-311).

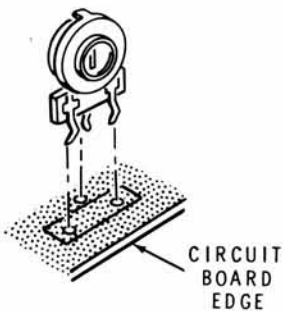

- R434: 5000 (5K) Ω control (#10-311).
- Solder the leads to the foil.

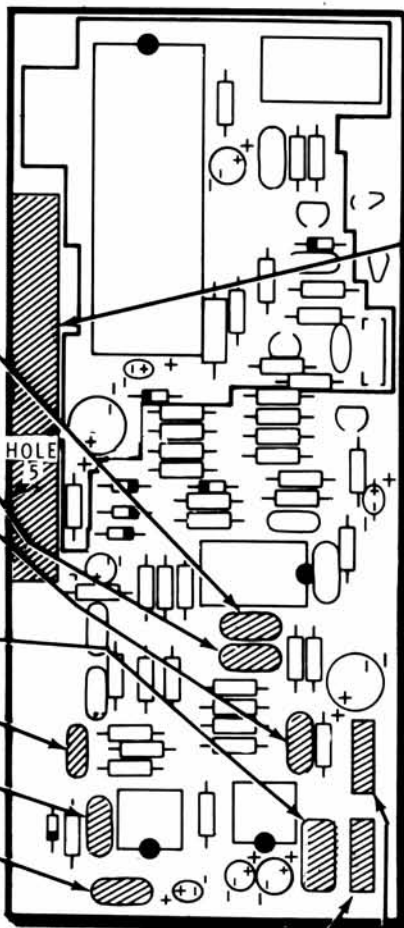

PICTORIAL 2-5

CONTINUE

- Press a polarizing pin into 25-pin connector hole 5 as shown on the circuit board. Disregard any numbers stamped on the connector.

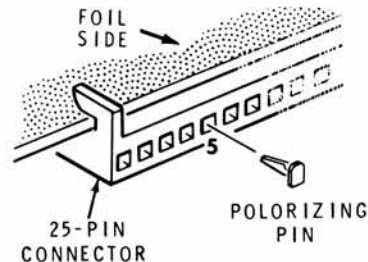

NOTE: This completes the tone decoder circuit board assembly. If you intend to install the optional RS-232C Output Accessory, proceed to that manual at this time. Otherwise, proceed to "Circuit Board Checkout."

CIRCUIT BOARD CHECKOUT

Carefully inspect the circuit board for the following conditions.

- Unsoldered connections.
- Poor solder connections.
- Solder bridges between foil patterns.
- Protruding leads which could touch together.
- Transistor and ICs for the proper installation.
- Diodes for the proper positioning of the banded end.
- Electrolytic capacitors for the correct position of the positive (+) or negative (-) mark.

Set the circuit board aside until it is called for later.

NOTE: You may wish to save the leftover WWV or WWVH components. If not, discard them.

MAIN AND TEST CIRCUIT BOARD

PARTS LIST

Remove the parts from Pack 3 and check each part against the following list. The key numbers correspond to the numbers on the "Main and Test Circuit Board Parts Pictorial" (Illustration Booklet, Page 3). Return any part that is in an individual envelope back into the envelope after you have identified it until that part is called for in a step. Do not throw away any packing material until you account for all the parts.

To order a replacement part, always include the PART NUMBER. Use the Parts Order Form furnished with this kit. If a Parts Order Form is not available, refer to "Replacement Parts" inside the rear cover of this Manual.

NOTE: If you find any extra parts in this pack, save them for use during the assembly of the cabinet.

KEY No.	HEATH Part No.	QTY.	DESCRIPTION	CIRCUIT Comp. No.
---------	----------------	------	-------------	-------------------

RESISTORS, 1/4-WATT, 5%

Refer directly to "Main and Test Circuit Board" on the enclosed resistor/diode sheet to check your resistors and diodes.

A1	6-220-12	1	22 Ω (red-red-blk)	R219
A1	6-271-12	1	270 Ω (red-viol-brn)	R222
A1	6-471-12	2	470 Ω (yel-viol-brn)	R212, R216
A1	6-102-12	2	1000 Ω (brn-blk-red)	R211, R221
A1	6-682-12	3	6800 Ω (blu-gry-red)	R206, R207, R214
A1	6-103-12	2	10 k Ω (brn-blk-org)	R209, R218
A1	6-223-12	3	22 k Ω (red-red-org)	R203, R204, R215
A1	6-333-12	1	33 k Ω (org-org-org)	R213
A1	6-473-12	1	47 k Ω (yel-viol-org)	R217
A1	6-104-12	2	100 k Ω (brn-blk-yel)	R205, R208

OTHER RESISTORS

NOTE: The following resistors are not located on the resistor/diode strip. They are inside the parts bag.

KEY No.	HEATH Part No.	QTY.	DESCRIPTION	CIRCUIT Comp. No.
---------	----------------	------	-------------	-------------------

A2	1-37	1	2.2 M Ω , 1/2-watt, 10% (red-red-grn)	R202
A3	3-49-5	1	3.9 Ω , 5-watt, 5%	R201
A4	9-157	1	Resistor pack	R223

CAPACITORS

Mica

B1	20-104	1	130 pF (131)	C219
B1	20-164	1	180 pF (181)	C218

Ceramic

B2	21-710	1	47 pF	C225
B2	21-17	3	270 pF (271)	C214, C215, C221
B2	21-821	1	4700 pF (472)	C211
B2	21-16	4	.01 μ F (103)	C201, C204, C207, C209
B2	21-199	3	.1 (.1M) μ F	C202, C222, C224
B3	21-711	2	470 (471) pF	C216, C223

KEY No.	HEATH Part No.	QTY.	DESCRIPTION	CIRCUIT Comp. No.
---------	----------------	------	-------------	-------------------

Electrolytic

B4	25-838	1	3.3 μ F (3U3 or 335) tantalum	C213
B5	25-927	1	22 μ F	C212
B5	25-887	1	220 μ F	C208
B5	25-893	2	1000 μ F	C205, C206
B5	25-895	1	2200 μ F	C203

DIODES

C1	56-56	16	1N4149	D206 - D209, D211 - D219, D221, D222, D223
C1	57-65	5	1N4002	D201 - D205
C2	56-640	1	MV2110*	D224

TRANSISTORS – INTEGRATED CIRCUITS

NOTE: Transistors and integrated circuits may be marked for identification in any one of the following four ways:

1. Part number.
2. Type number. (On integrated circuits, use **only** those numbers and letters in **BOLD** print. Disregard any other numbers or letters.)
3. Part number and type number.
4. Part number with a type number other than the one shown.

CAUTION: The ICs are protected against damage caused by static electricity. Do NOT remove the ICs from their foam pads until you are instructed to do so in a step.

C3	417-874	1	2N3906 transistor	Q207
C3	417-293	1	2N5770 transistor	Q204
C3	417-801	5	MPSA20 transistor	Q201, Q202, Q203, Q205, Q206
C4	442-54	1	UA7805	U202
C4	442-691	1	78M08 or 7808	U201
C5	443-1202	1	MC14028	U204
C5	443-736	1	MC14508	U205
C5	444-293-1	1	Programmed microprocessor	U203

* Part not on resistor/diode strip.

KEY No.	HEATH Part No.	QTY.	DESCRIPTION	CIRCUIT Comp. No.
---------	----------------	------	-------------	-------------------

CHOKE – TRANSFORMER

D1	230-8492	1	26 μ H choke	L201
D2	54-1013	1	Power transformer	T201

CONNECTOR – SOCKETS

E1	432-946	3	25-pin connector
E2	434-299	1	16-pin IC socket
E2	434-307	1	24-pin IC socket
E2	434-253	1	40-pin IC socket

HARDWARE

F1	230-8290	1	M3 \times 6 mm screw
F2	230-8393	4	M3 \times 6 mm self-tapping screw
F3	230-8438	1	M3 nut
F4	230-8440	1	M3 lockwasher

MISCELLANEOUS

G1	230-8296	2	DIP switch	S201, S202
	85-2867-2	1	Main circuit board	
G2	215-65	1	Heat sink	
G3	346-60	1-1/2"	Clear tubing	
	343-12	6"	50 Ω coaxial cable (located in the Final Pack)	
	347-55	12"	8-wire ribbon cable*	
G4	352-31	1	Thermal compound	
G5	404-658	1	3.6 MHz crystal	Y201
G6	260-65	4	Fuse clip	
G7	421-31	1	3/16-ampere slow-blow fuse	F201
G7	421-37	1	1-ampere fuse	F202

TEST CIRCUIT BOARD PARTS (located in envelope #173-1833)*

H1	6-102-12	1	1000 Ω , 1/4-watt, 5% (brn-blk-red) resistor	R501
	85-2912-2	1	Test circuit board	
H2	60-685	1	Slide switch	S501
H3	64-967	1	Pushbutton switch	S502

* These parts may be located in the final pack.

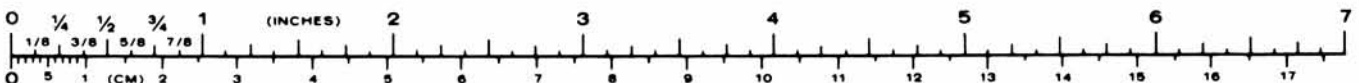

STEP-BY-STEP ASSEMBLY

MAIN CIRCUIT BOARD

The steps performed in this Pictorial are in this area of the circuit board.

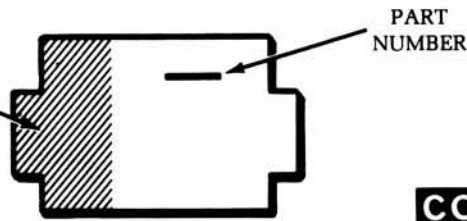

IDENTIFICATION DRAWING

START

() Position the main circuit board with the white printed side (not the foil side) facing up. NOTE: Only a portion of the circuit board is shown in some Pictorials. The small "Identification Drawing" at the top of a Pictorial shows the area of the circuit board to be assembled.

(/) R202: 2.2 MΩ, 1/2-watt, 10% (red-red-grn).

NOTE: Remove the resistors from the "Main and Test Circuit Boards" resistor strip for this section.

(/) R222: 270 Ω (red-viol-brn).

() R221: 1000 Ω (brn-blk-red).

() R217: 47 kΩ (yel-viol-org).

(>) R219: 22 Ω (red-red-blk).

(>) R218: 10 kΩ (brn-blk-org).

() R216: 470 Ω (yel-viol-brn).

() Solder the leads to the foil and cut off the excess lead lengths.

NOTE: DIODES MAY BE SUPPLIED IN ANY OF THE FOLLOWING SHAPES. ALWAYS POSITION THE BANDED END AS SHOWN ON THE CIRCUIT BOARD.

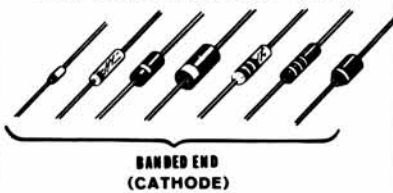

Detail 3-1A

CONTINUE

NOTE: When you install a diode in the following steps, be sure to position the banded end as shown on the circuit board. THE CIRCUIT WILL NOT WORK IF A DIODE IS INSTALLED BACKWARDS.

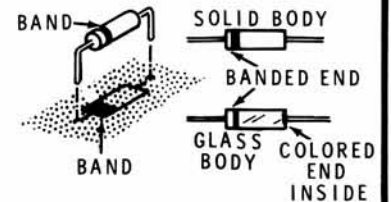

CAUTION: ALWAYS POSITION THE BANDED END OF A DIODE AS SHOWN ON THE CIRCUIT BOARD.

If your diode has a solid body, the band is clearly defined. If your diode has a glass body, do not mistake the colored end inside the diode for the banded end. Look for a band painted on the outside of the glass. See Detail 3-1A.

() D201: 1N4002 diode (#57-65).

Install four more 1N4002 (#57-65) diodes as follows:

() D202.

() D203.

() D205.

() D204.

() Solder the leads to the foil and cut off the excess lead lengths.

PICTORIAL 3-1

IDENTIFICATION
DRAWING

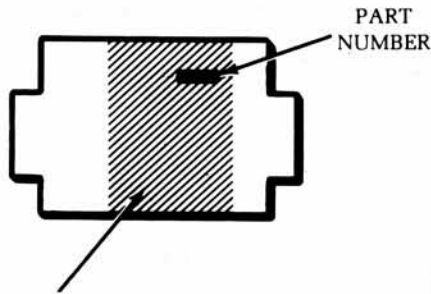

The steps performed in this Pictorial are in this area of the circuit board.

START ↘

- () R214: 6800 Ω (blu-gry-red).
- (/) R215: 22 kΩ (red-red-org).
- () R208: 100 kΩ (brn-blk-yel).
- () R209: 10 kΩ (brn-blk-org).
- () R211: 1000 Ω (brn-blk-red).
- () R213: 33 kΩ (org-org-org).
- () R212: 470 Ω (yel-viol-brn).
- () R203: 22 kΩ (red-red-org).
- () R204: 22 kΩ (red-red-org).
- () Solder the leads to the foil and cut off the excess lead lengths.

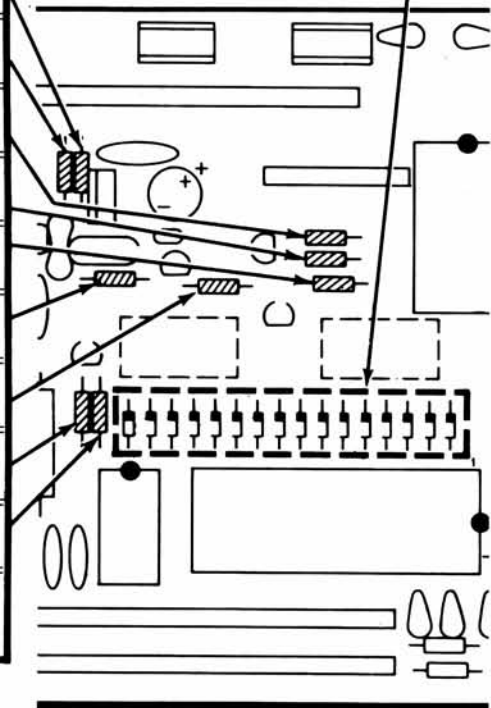

CONTINUE ↘

Install sixteen 1N4149 (#56-56) diodes as follows. NOTE: If your diodes have color bands (yellow-black-yellow-white), the end that has a wide yellow band is the banded end.

- (-) D214.
- () D213.
- () D212.
- () D206.
- () D215.
- () D207.
- () D208.
- () D209.
- () D211.
- () D221.
- () D222.
- (/) D223.
- (/) D219.
- (/) D218.
- () D217.
- () D216.
- () Solder the leads to the foil and cut off the excess lead lengths.

PICTORIAL 3-2

IDENTIFICATION
DRAWINGPART
NUMBER

The steps performed in this Pictorial are
in this area of the circuit board.

START →

- () R205: 100 k Ω (brn-blk-yel).
- () R206: 6800 Ω (blu-gry-red).
- () R207: 6800 Ω (blu-gry-red).
- () Solder the leads to the foil and cut off the excess lead lengths.

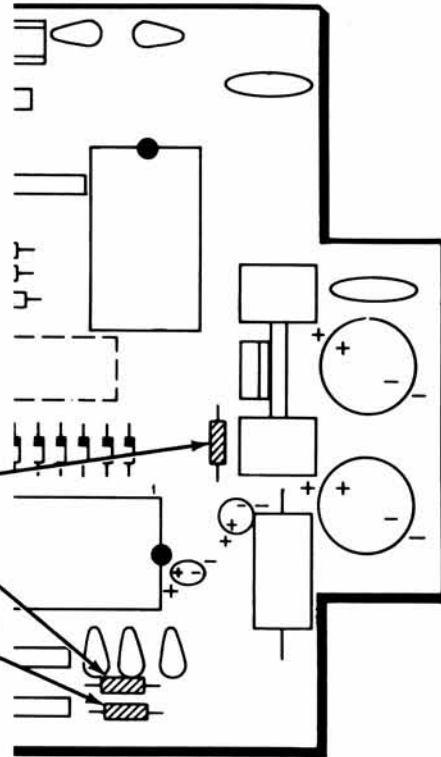

PICTORIAL 3-3

START

NOTE: You will install IC sockets in the following steps. Make sure all pins are straight and insert the socket pins into the circuit board holes. Turn the circuit board over, be sure there is a pin in each of the holes, and then solder two diagonal corner pins of the IC socket to the foil. Check to make sure the IC socket is flat against the circuit board; then solder the remaining pins to the foil. If the socket is indexed, position the index mark over the index outline on the board

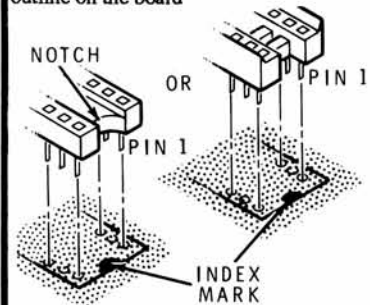

() 24-pin IC socket at U205.

() 40-pin IC socket at U203.

() 16-pin IC socket at U204.

Carefully check each socket for solder bridges between pins. If a solder bridge has occurred, hold the circuit board foil-side-down as shown, and hold the soldering iron tip between the two points that are bridged. The solder will flow down the soldering iron tip.

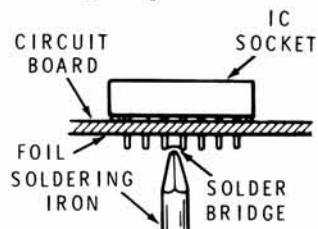

() L201: 26 μ H choke (230-8492) at L201. Position the choke body as shown and bend the leads as shown. Insert the leads into the circuit board holes and solder them to the foil. Cut off the excess lead lengths.



IDENTIFICATION DRAWING

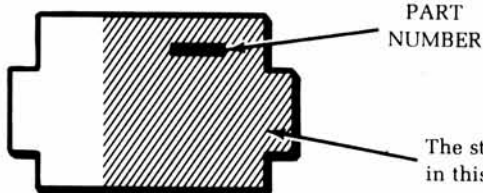

The steps performed in this Pictorial are in this area of the circuit board.

CONTINUE

() R223: Resistor pack. Position the dot or bar next to the "1" on the circuit board. Solder the pins to the foil and cut off the excess pin lengths.

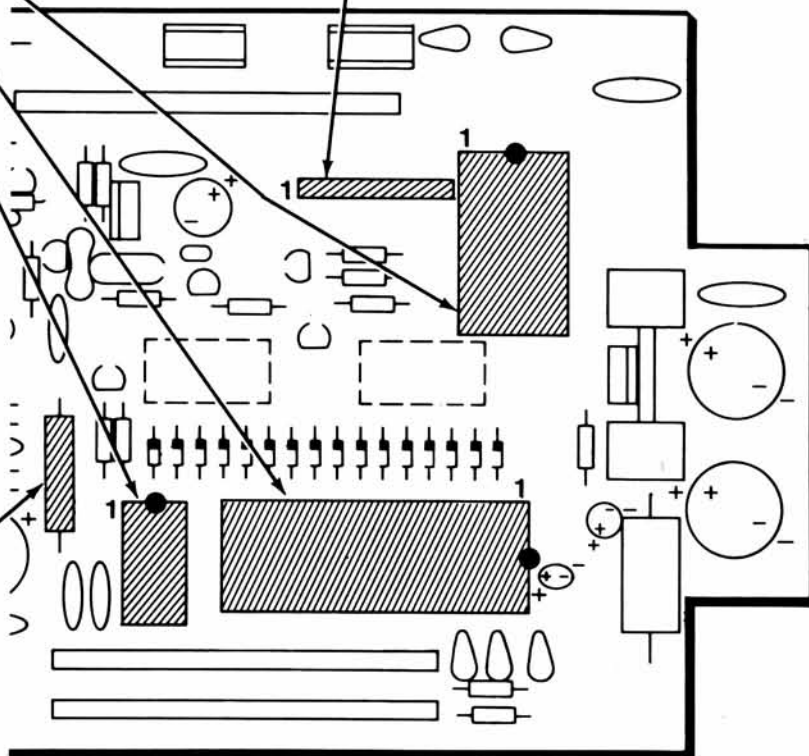
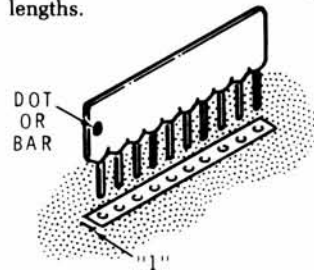

PICTORIAL 3-4

IDENTIFICATION
DRAWING

The steps performed in this Pictorial are in this area of the circuit board.

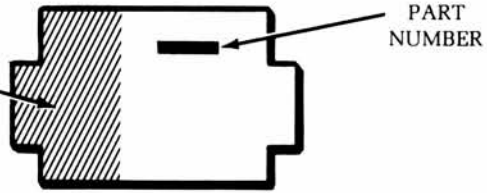

START ↘

() F201: Fuse clips. Position the fuse clips shoulders as shown and solder the tabs to the foil.

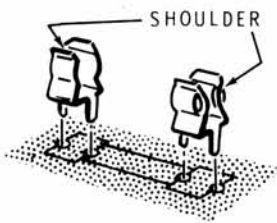

() Prepare the 1-1/2" piece of clear plastic sleeving as shown.

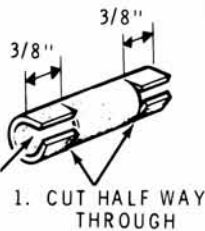

() F201: Insert the 3/16-ampere slow-blow fuse into 1-1/2" of clear plastic tubing and install the fuse into the fuse clips.



CONTINUE ↘

NOTE: When you install each of the following transistors, position the flat of the transistor over the outline of the flat on the circuit board. Then insert the leads into the circuit board holes and solder them to the foil. Cut off any excess lead lengths.

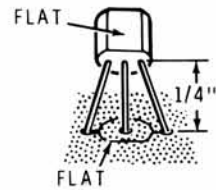

() Q207: 2N3906 transistor (#417-874).

() Q206: MPSA20 transistor (#417-801).

() Q205: MPSA20 transistor (#417-801).

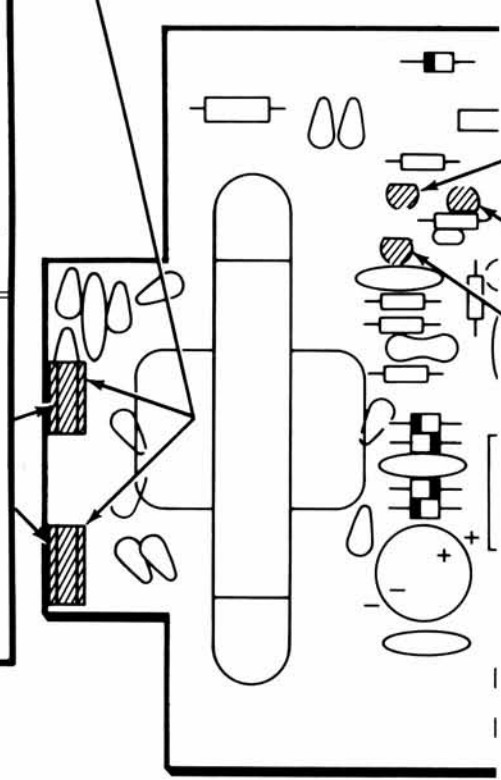

PICTORIAL 3-5

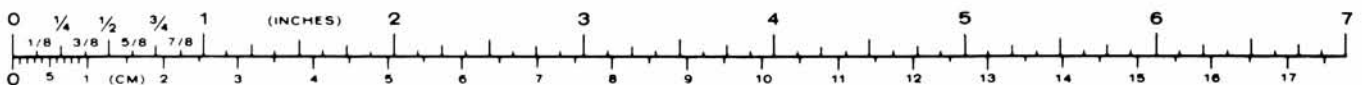

IDENTIFICATION
DRAWING

PART
NUMBER

The steps performed in this Pictorial are in this area of the circuit board.

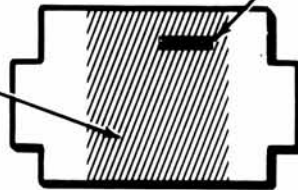

CONTINUE

START

- (/) F202: Fuse clips. Position the fuse clips shoulders as shown and solder the tabs to the foil.

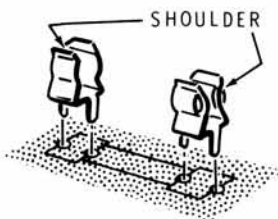

- () F202: Insert the 1-ampere fuse into the fuse clips.

- () Q203: MPSA20 transistor (#417-801).

- () Q202: MPSA20 transistor (#417-801).

- () Q204: 2N5770 transistor (#417-293).

- () Q201: MPSA20 transistor (#417-801).

- () D224: Position the case flat of the MV2110 (#56-640) diode over the outlined flat on the circuit board. Insert the leads into the circuit board holes and position the case bottom 1/4" above the circuit board. Solder the leads to the foil and cut off the excess lead lengths.

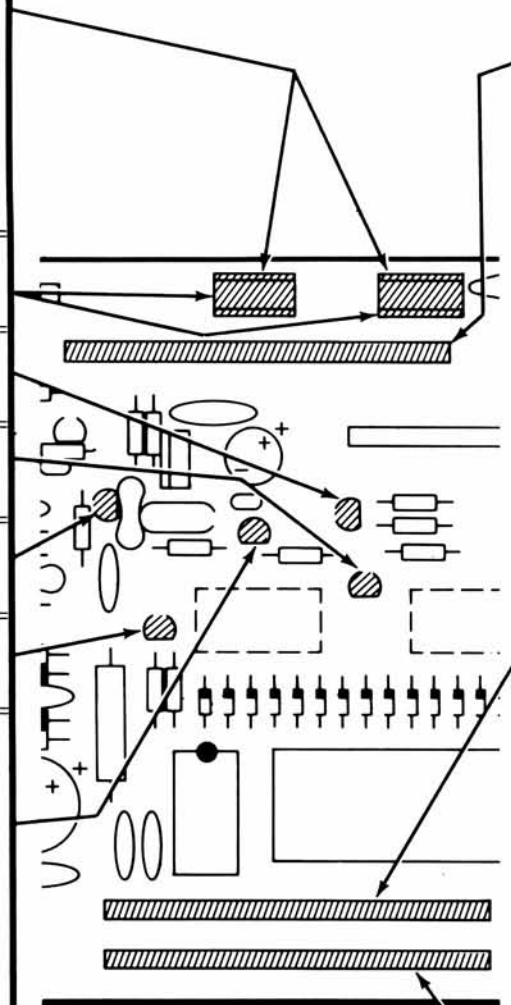
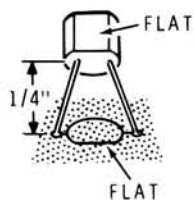

PICTORIAL 3-6

- () Remove pin 2 from either end of a 25-pin connector to make a 24-pin connector.

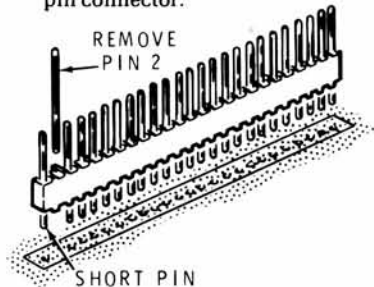

- () P201: Install the 24-pin connector at P201. Insert the short pin end into the circuit board holes and press the connector body against the circuit board. Solder the pins to the foil.

- () Remove pin 5 from either end of another 25-pin connector to make a 24-pin connector.

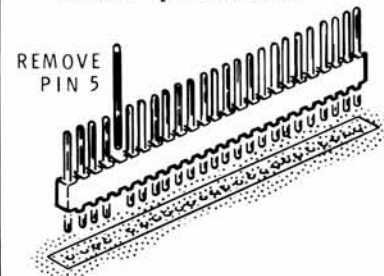

- () P202: Install the 24-pin connector at P202. Solder the pins to the foil.

- () Remove pin 3 from either end of the remaining 25-pin connector.

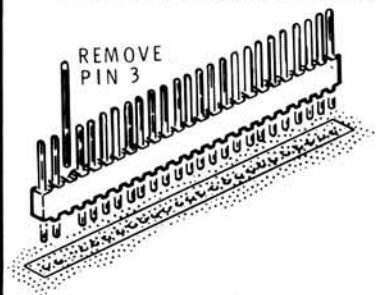

- () P203: Install the 24-pin connector at P203. Solder the pins to the foil.

IDENTIFICATION
DRAWING

The steps performed in this Pictorial are in this area of the circuit board.

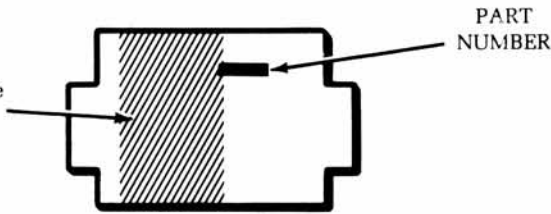

START ↘

NOTE: When you install ceramic capacitors, do not push the insulated portion of the leads into the circuit board holes. This could make it difficult to solder the leads to the foil.

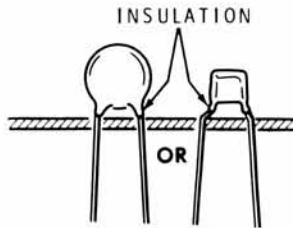

- () C209: .01 μ F (103) ceramic.
- () C223: 470 (471) pF ceramic.
- () C218: 180 pF (181) mica.
- (-) C222: .1 (.1M) μ F ceramic.
- () C221: 270 pF (271) ceramic.
- () C219: 130 pF (131) mica.
- () C202: .1 (.1M) μ F ceramic.
- () C204: .01 (103) μ F ceramic.
- () Solder the leads to the foil and cut off the excess lead lengths.

CONTINUE ↘

NOTE: Before you install a polarized electrolytic capacitor, look at it and identify the leads. One lead will have a positive (+) mark or a negative (-) mark near it. **Be sure** to install the positive lead in the positive-marked hole or the negative lead in the negative-marked hole.

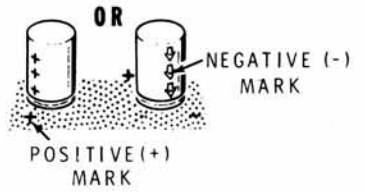

- () C208: 220 μ F electrolytic.
- () C216: 470 (471) pF ceramic.
- () Y201: 3.6 MHz crystal.
- () C215: 270 pF (271) ceramic.
- () C214: 270 pF (271) ceramic.
- () Solder the leads to the foil and cut off the excess lead lengths.

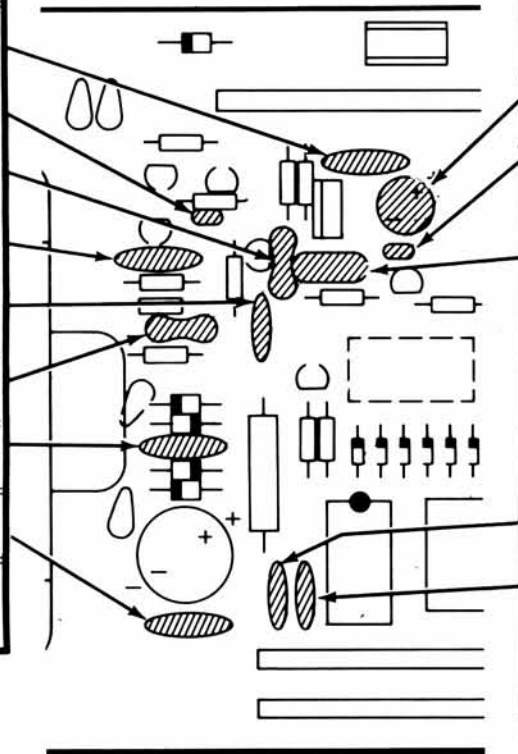

PICTORIAL 3-7

The steps performed in this Pictorial are in this area of the circuit board.

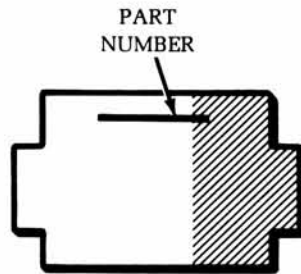

IDENTIFICATION DRAWING

START

() C201: .01 μ F (103) ceramic.

() C207: .01 μ F (103) ceramic.

() C212: 22 μ F electrolytic.

NOTE: When you install tantalum electrolytic capacitors, be sure to position the plus (+) marked or dot (•) marked lead in the plus (+) marked hole.

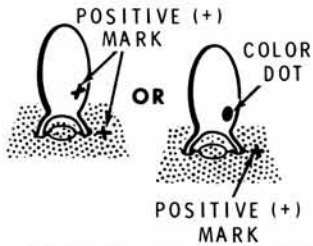

() C213: 3.3 μ F (3U3 or 335) tantalum.

() Solder the leads to the foil and cut off the excess lead lengths.

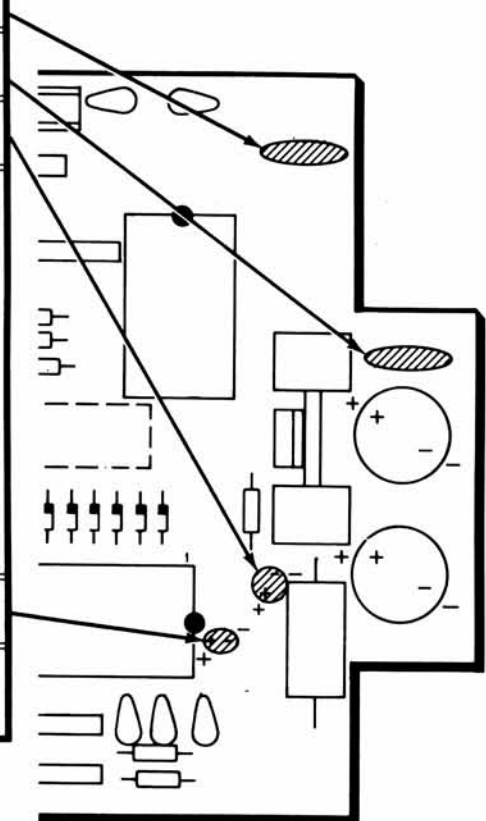

PICTORIAL 3-8

START 

- () U201: 78M08 (#442-691) integrated circuit. Insert the leads as far as possible into the circuit board holes. Keep the IC perpendicular to the circuit board and solder the leads to the foil and cut off excess lead lengths.

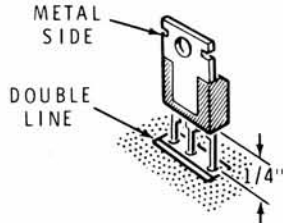

- () C211: 4700 pF (472) ceramic.
- () C203: 2200 µF electrolytic.
- () Solder the leads to the foil and cut off the excess lead lengths.
- () Turn the circuit board over so that the foil side is facing up.

Refer to Detail 3-9A for the following steps:

- () Cut the leads of a 47 pF ceramic capacitor to 1/8".
- () C225: Locate the foil pads on the foil side of the circuit board for the indicated leads of capacitor C222 and transistor Q205. Place the prepared 47 pF ceramic capacitor so the lead ends are over the foil pads and solder the leads to the foils. Keep the capacitor flat against the circuit board. Cut off any excess lead lengths so you do not bridge the foils.

The steps performed in this Pictorial are in this area of the circuit board.

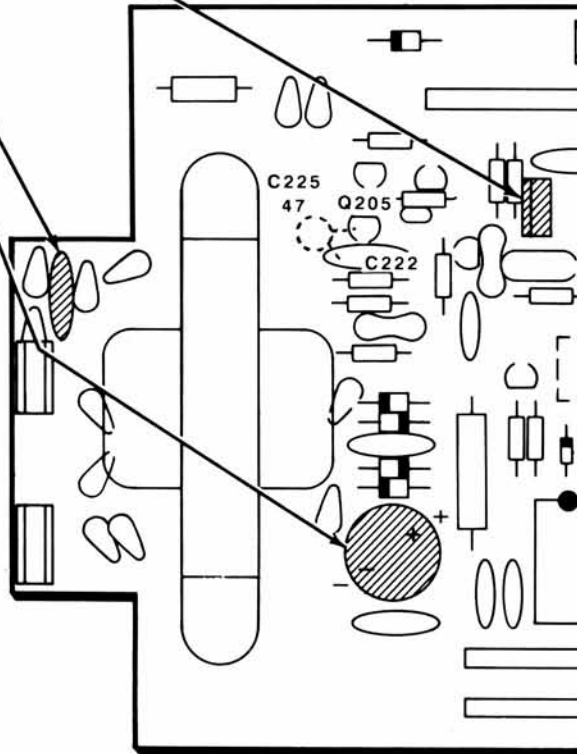
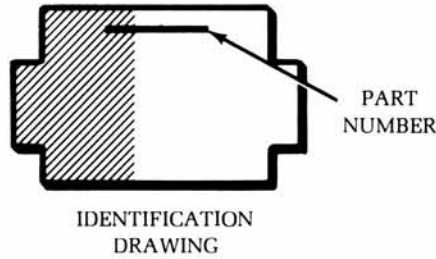

PICTORIAL 3-9

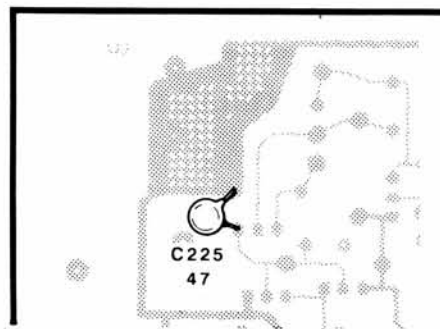

Detail 3-9A

The steps performed in this Pictorial are in this area of the circuit board.

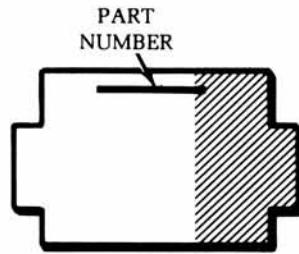

IDENTIFICATION DRAWING

START ↓

- () C206: 1000 μ F electrolytic.

- () C205: 1000 μ F electrolytic.

- () Cut two 3/4" pieces of sleeving.

- () Slide the 3/4" sleeving over the 3.9 Ω , 5-watt resistor leads and bend the leads down 90°.

- (/) R201: 3.9 Ω , 5-watt, 10% resistor with sleeving.

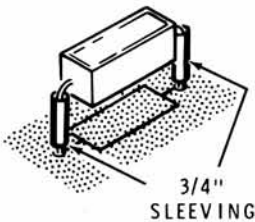

- (/) Solder the leads to the foil and cut off the excess lead lengths.

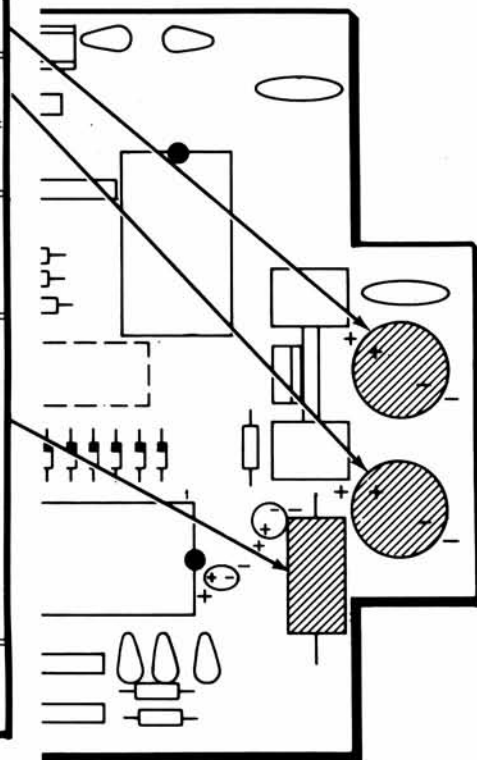

PICTORIAL 3-10

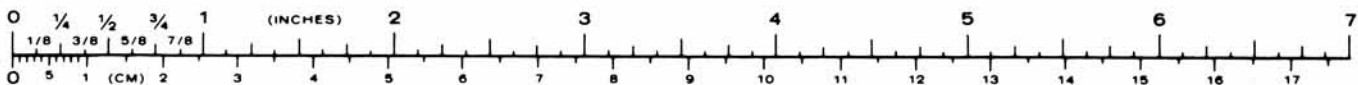

START 

WARNING: You will use Dow Corning 340 thermal compound in the next step. The compound is not caustic, but it may cause discomfort if it gets in your eyes. If this happens, rinse your eyes with warm water. Your clothes may require professional cleaning if the compound gets on them. The compound contains zinc oxide and silicone grease. Always wash your hands after using the compound. Keep this and all chemicals out of the reach of children.

() Oper. the thermal compound container.

() Apply a small amount of thermal compound to the bare metal side of the UA7805 integrated circuit (#442-54). Discard the remaining compound.

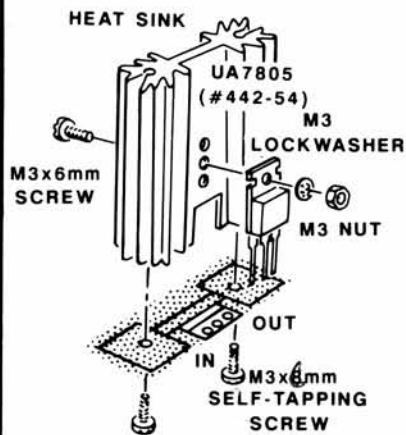

() U202: Assemble and mount a transistor heat sink assembly as follows:

1. Mount the prepared IC on the heat sink with a $M3 \times 6$ mm screw, an M3 lockwasher, and an M3 nut as shown.
2. Mount the transistor heat sink assembly onto the circuit board at U202 with two $M3 \times 6$ mm self-tapping screws. 
3. Solder the transistor leads to the foil and cut off the excess lead lengths.

The steps performed in this Pictorial are in this area of the circuit board.

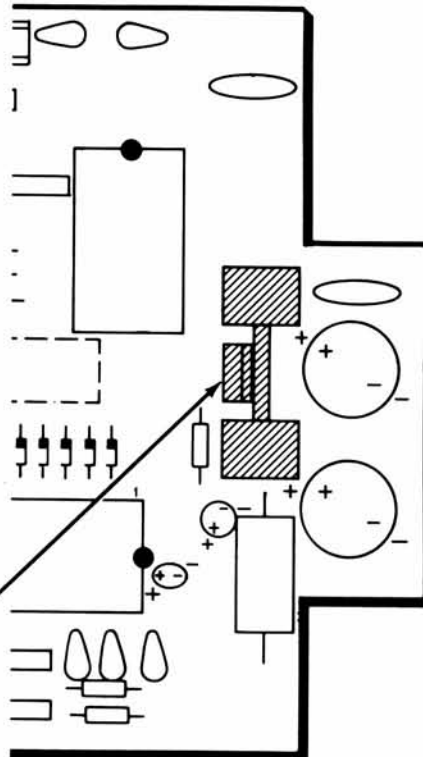
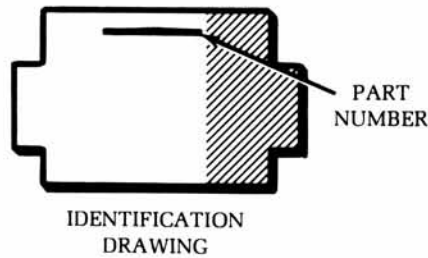

PICTORIAL 3-11

START →

CAUTION: When you install the following protected IC (mounted on a foam pad), be sure it does not get damaged by static electricity. Once you remove the foam pad, DO NOT let go of the IC. Install it as follows. Read the entire step before you pick up the IC.

1. Pick up the IC and touch the foam pad with both hands.
2. Hold the IC with one hand and remove the foam pad with the other hand.
3. Continue to hold the IC with one hand and roll the IC pins onto a flat surface to make sure they are parallel.
4. Pick up the circuit board in your other hand.
5. Align the pin 1 end of the IC with the index mark on the circuit board.
6. Then push the IC pins into the IC socket. Once in the socket, the IC is protected.

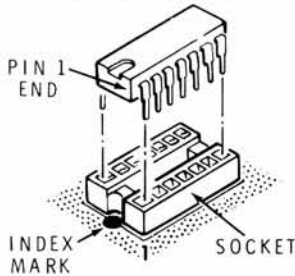

Install ICs at the following locations:

- () MC14508 (#443-736) at U205.
- () MC14028 (#443-1202) at U204.
- () 3870 (#444-293-1) at U203.

Should it ever become necessary to remove an IC, use the IC puller. Insert the IC puller beneath the IC; then gently rock it back and forth to lift the IC.

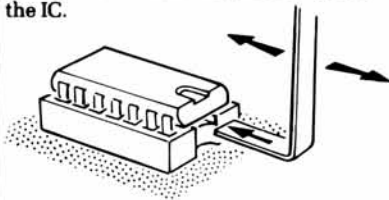

The steps performed in this Pictorial are in this area of the circuit board.

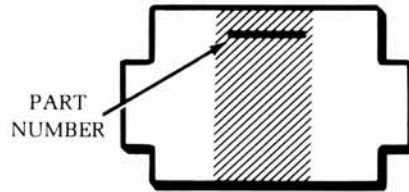

IDENTIFICATION
DRAWING

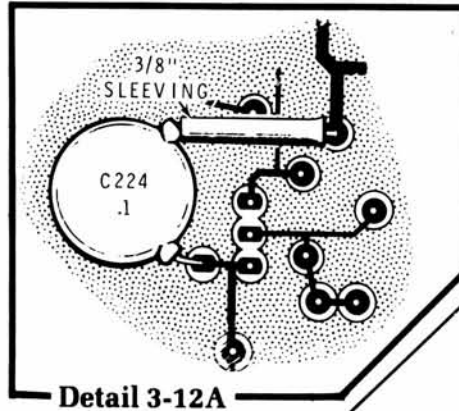

Detail 3-12A

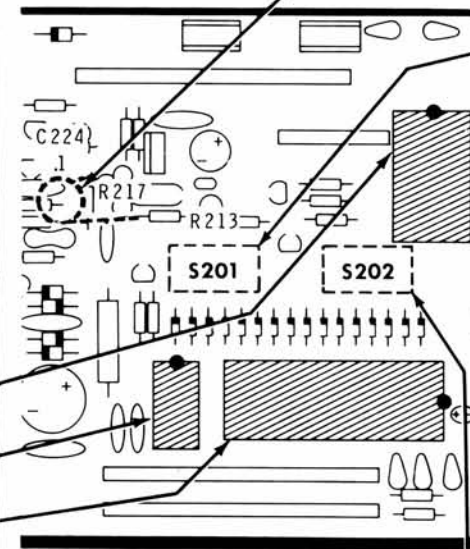

PICTORIAL 3-12

CONTINUE →

- () Turn the circuit board over so that the foil side is facing up.

Refer to Detail 3-12A for the following steps.

- () Cut the leads of a .1 μ F (.1M) ceramic capacitor to 1/8" and 1/2".
- () Cut a 3/8" piece of sleeving and slide it over the 1/2" capacitor lead.
- () C224: Locate the foil pads on the foil side of the circuit board below the indicated leads of resistors R217 and R213. Place the prepared .1 μ F ceramic capacitor so the lead ends are over the foil pads and solder the leads to the foils. Keep the capacitor flat against the circuit board. Cut off any excess lead lengths so you do not bridge the foils.

- () Note the foil pattern at S201. Then insert one of the DIP switches into the circuit board foil side holes at S201 with the "O" or "ON" side as shown. Disregard any numbers on the switch. Turn the circuit board back over and solder the pins to the component side foils at S201. Keep the switch body flat against the circuit board.

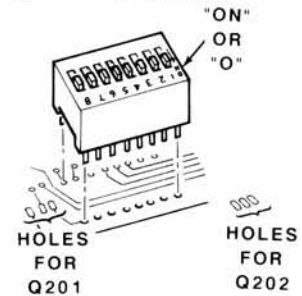

- () Similarly, mount the remaining DIP switch at S202. Position the switch with the "O" or "ON" side the same as S201.

Set the main circuit board aside temporarily.

TEST CIRCUIT BOARD

START →

- () Position the test circuit board with the printed side up.
- () Mount the pushbutton switch at S502. Straighten the pins and press them into the circuit board holes as far as possible. Then solder the pins to the foil.

PUSHBUTTON SWITCH

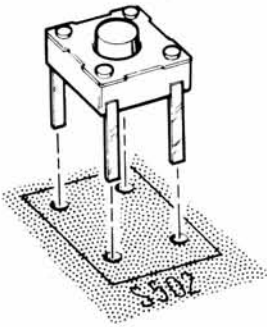

- () R501: 1000 Ω (brn-blk-red). Solder the leads to the foil and cut off the excess lead lengths.

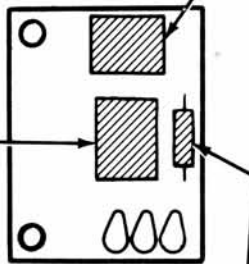

CONTINUE ↓

- () Cut off the four corner pins from the slide switch as shown, if this has not already been done.

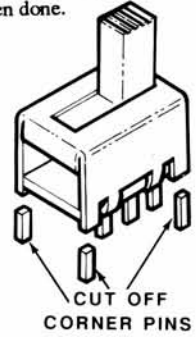

- () Mount the slide switch at S501. Press the pins into the circuit board holes as far as possible. Then solder the pins to the foil.

- () Mount the test circuit board assembly to the main circuit board heat sink with two M3 × 6 mm self-tapping screws.

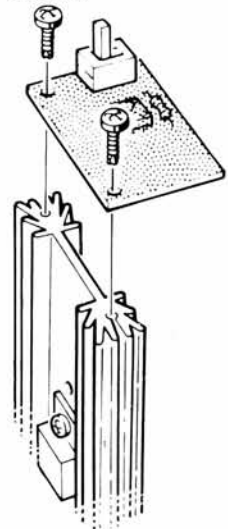
M3X6mm
SELF-TAPPING
SCREW

PICTORIAL 3-13

Heathkit®

Refer to Pictorial 3-14 (Illustration Booklet, Page 4) for the following steps.

NOTE: In the following steps, you will prepare stranded wires from the 8-wire ribbon cable groups. To prepare a stranded wire, cut the wire, or group of wires, to the indicated length, separate the wires (if in a group) as specified in the Detail, and remove 1/4" of insulation from the wire ends. Twist the wire strands tightly together at each wire end and apply a small amount of solder to hold the strands together.

- () Locate the 12" 8-wire ribbon cable and separate the following wires, as a group, from the cable. Use a pair of cutters or a knife to start to separate the wires:

One brown and red.
One orange, yellow, and green.

- () Cut a 2" brown and red wire pair.

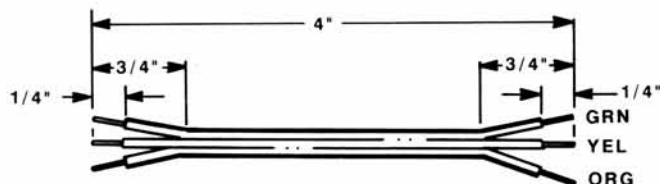
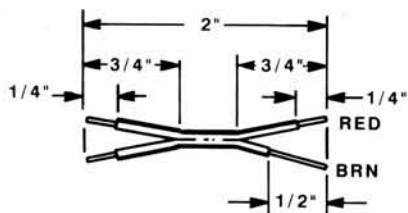

Detail 3-14A

- () Refer to Detail 3-14A and separate each end of the 2" red and brown wires for 3/4" and prepare the ends. Remove an additional 1/4" of insulation from one end of the brown wire.

NOTE: Whenever you are instructed to connect a wire to the circuit board, solder each wire after you connect it and cut off the excess wire length from the foil side.

Connect the 1/4" prepared ends of the red and brown wire pair to the main circuit board as follows.

- () Red wire at hole K.
() Brown wire at hole J.

You will connect the other end of these wires later.

- () Cut a 2" piece of 50 Ω coaxial cable and prepare the ends as shown in Detail 3-14B.

- () Connect the inner lead at end A of the 2" coaxial cable to circuit board hole P and the shield lead to hole Q. Solder the leads after you connect them and cut off any excess lead lengths. You will connect the other end of the cable later.

You will connect the other end of these wires later.

- () Cut a 4" orange, yellow, and green wire group.
() Refer to Detail 3-14A and separate the wires at each end of the group for 3/4" and prepare the ends.

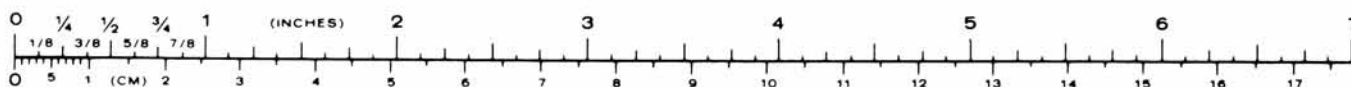

Connect one end of the orange, yellow, and green wire group to the main circuit board as follows:

- () Orange wire at hole N.
- () Yellow wire at hole L.
- () Green wire at hole M.

Connect the other end of the orange, yellow, and green wire group to the test circuit board as follows:

- () Yellow wire to hole L.
- () Orange wire to hole N.
- () Green wire to hole M.

Set the remaining wire aside.

ALTERNATE LINE VOLTAGE WIRING

Two sets of line voltage wiring instructions are given below, one for 120 VAC line voltage and the other for 240 VAC line voltage. In the U.S.A., 120 VAC is most often used, while in other countries, 240 VAC is more common. USE ONLY THE INSTRUCTIONS THAT AGREE WITH THE LINE VOLTAGE IN YOUR AREA.

NOTE: The plug on the power cord for this kit is for standard 120 VAC outlets in most of North America. For 240 VAC operation in other countries, cut off and replace this plug with a permanent plug that matches your 240 VAC receptacle.

120 VAC Wiring

Refer to Pictorial 3-15 (Illustration Booklet, Page 4) Part A for the following steps.

- () Refer to Detail 3-15A and cut the power transformer leads to the indicated lengths. Measure the leads from where they leave the transformer body.

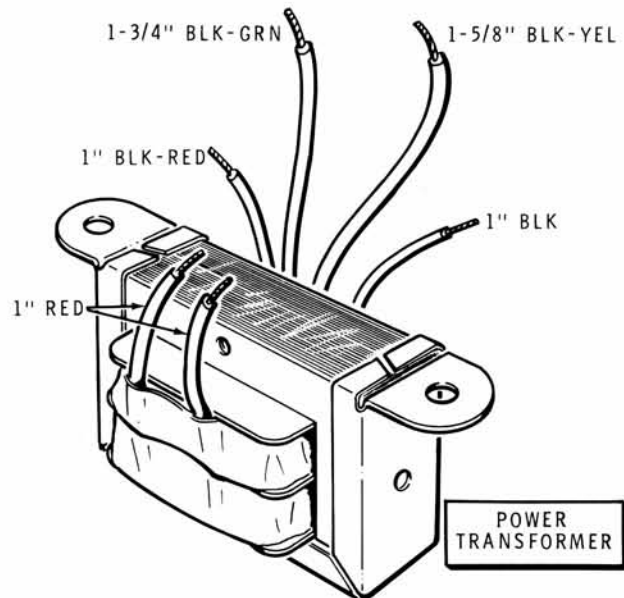

Detail 3-15A

- () Remove 1/4" of insulation from the end of each power transformer lead.

Insert the power transformer leads into the circuit board holes as follows. Solder each lead to the foil after you connect it and cut off the excess lead lengths.

- () Either red lead at hole G.
- () Remaining red lead at hole H.
- () Black-red lead at hole F.
- () Black-yellow lead at hole D.
- () Black lead at hole E.
- () Black-green lead at hole C.

You will secure the power transformer later. Leave it loose for now.

This completes the "120 VAC Wiring." Proceed to "Circuit Board Checkout."

240 VAC Wiring

Refer to Pictorial 3-15 (Illustration Booklet, Page 4) Part B for the following steps.

- () Refer to Detail 3-15B and cut the power transformer leads to the indicated lengths. Measure the leads from where they leave the transformer body.

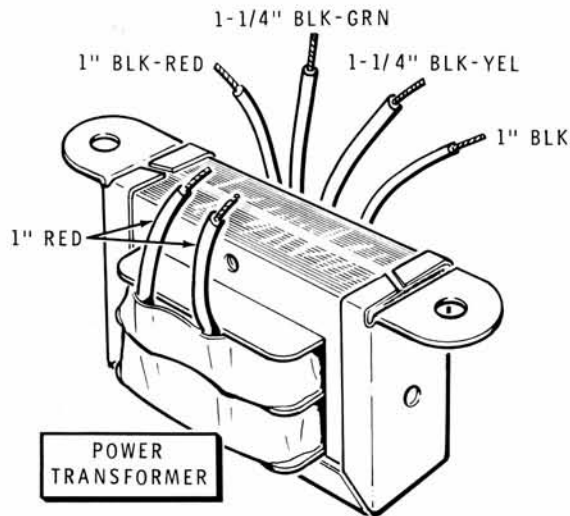

Detail 3-15B

- () Remove 1/4" of insulation from the end of each power transformer lead.

Insert the power transformer leads into the circuit board holes as follows. Solder each lead to the foil after you connect it and cut off the excess lead length.

- () Either red lead to hole G.
 () Remaining red lead to hole H.
 () Black-red lead to hole F.
 () Black-yellow lead to hole Y.
 () Black-green lead to hole Z.
 () Black lead to hole C.

You will secure the power transformer later. Leave it loose for now.

This completes the "240 VAC Wiring." Proceed to "Circuit Board Checkout."



CIRCUIT BOARD CHECKOUT

Carefully inspect the main and test circuit boards for the following most commonly made errors:

- Unsoldered connections.
- Poor solder connections.
- Protruding leads which could touch together.
- Diodes installed backwards or at the wrong location.
- Transistors and integrated circuits improperly installed.
- Polarized electrolytic capacitors installed backwards.

This completes the "Main Circuit Board" and "Test Circuit Board Assembly." Set the assembly aside and proceed to "Cabinet."

CABINET

PARTS LIST

Remove the remaining parts from the carton and check each part against the following list. The key numbers correspond to the numbers on the "Cabinet Parts Pictorial" (Illustration Booklet, Page 5). Return any part that is in an individual envelope back into the envelope after you have identified it until that part is called for in a step. Do not throw away any packing material until you account for all the parts.

To order a replacement part, always include the PART NUMBER. Use the Parts Order Form furnished with this kit. If a Parts Order Form is not available, refer to "Replacement Parts" inside the rear cover of this Manual.

KEY No.	HEATH Part No.	QTY.	DESCRIPTION	CIRCUIT Comp. No.
---------	----------------	------	-------------	-------------------

HARDWARE

M3 Hardware

A1	230-8470	4	M3 × 6 mm self-tapping screw	
A2	230-8290	2	M3 × 6 mm screw	
A3	230-8393	4	M3 × 8 mm self-tapping screw	
A4	230-8438	2	M3 nut	
A5	230-8440	4	M3 lockwasher	
A6	230-8479	1	M3 setscrew (May be installed in knob)	
A7	230-8483	1	M3 solder lug	
A8	230-8489	2	M3 press-in nut (May already be installed in cabinet)	
A9	230-8490	2	M3 flat washer	
A10	230-8475	3	M3 × 10 mm screw	
A11	230-8491	2	M3 × 6 mm flat head screw	

KEY No.	HEATH Part No.	QTY.	DESCRIPTION	CIRCUIT Comp. No.
---------	----------------	------	-------------	-------------------

M3.5 Hardware

B1	230-8392	2	M3.5 × 14 mm screw	
B2	230-8394	2	M3.5 nut	
B3	230-8446	4	M3.5 × 12 mm self-tapping screw	
B4	230-8472	2	M3.5 round plastic spacer	

OTHER HARDWARE

C1	230-8486	2	M2.6 × 6 mm screw	
C2	258-730	4	Clamp	
C3	259-27	2	Large solder lug	

KEY No.	HEATH Part No.	QTY.	DESCRIPTION	CIRCUIT Comp. No.
---------	----------------	------	-------------	-------------------

KEY No.	HEATH Part No.	QTY.	DESCRIPTION	CIRCUIT Comp. No.
---------	----------------	------	-------------	-------------------

PLASTIC AND NYLON PARTS

D1	75-182	1	Strain relief	
D2	92-828	1	Cabinet top	
D3	92-753	1	Cabinet bottom	
D4	261-49	4	Foot	
D5	446-751	1	Window	
D6	230-8471	1	Knob	
D7	485-18	1	Round plug	
D8	485-42	1	Rectangular plug	

BRACKETS - CONNECTORS

E1	230-8487	1	Back panel	
E2	204-2683	1	Angle bracket	
E3	230-8468	1	Antenna bracket	
E4	432-865	4	3-hole connector	
E5	432-866	9	Spring connector	
E6	432-892	2	Female BNC connector	
E7	230-8474	1	Male BNC connector	
E8	230-8484	1	Power jack	J1
E9	230-8485	1	Power plug	S1

CABLE

343-12	7'	RG-174 coaxial	
344-2	3"	Black stranded wire	
347-50	20'	2-wire	

MISCELLANEOUS

F1	6-333-12	1	33 kΩ, (org-org-org) 1/4-watt, 5% resistor	Test
F2	230-8473	1	20 kΩ control	R1
F3	60-604	1	Slide switch	S101
F4	89-19	1	Line cord	
F5	230-8480	1	Antenna	L1
	181-4332	1	Assembled receiver circuit board	
F6	401-176	1	Speaker	SP1
F7	209-97	1	Speaker grille	
F8	266-1218	2	Wire screen	



STEP-BY-STEP ASSEMBLY

BACK PANEL COMPONENTS

Refer to Pictorial 4-1 (Illustration Booklet, Page 6) for the following steps.

- () Refer to Detail 4-1A and position the cabinet bottom with the bottom side up as shown.

- () The M3 press-in nuts may already be installed. If not, refer to Detail 4-1A and install M3 brass press-in nuts in cabinet bottom holes AA and AB. Use your soldering iron to install the press-in nuts as shown.

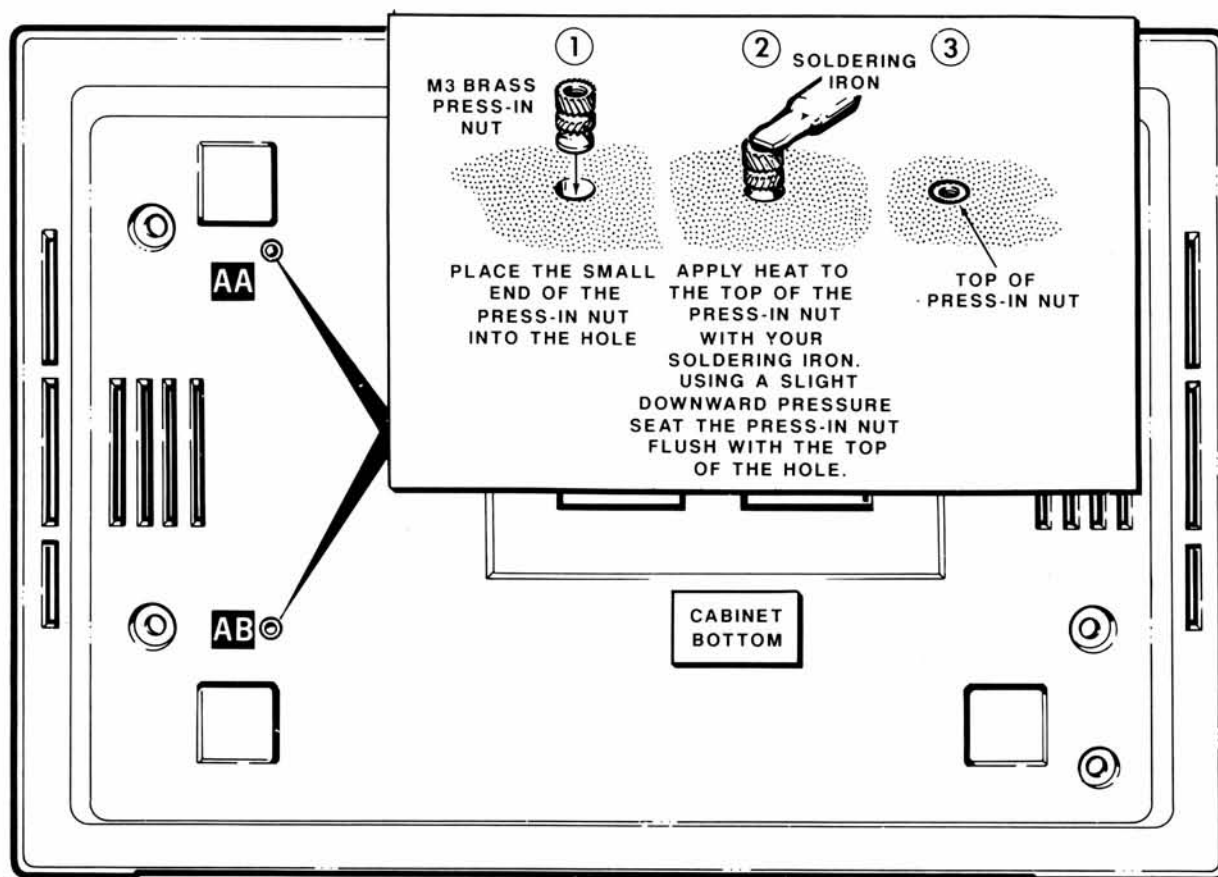

Detail 4-1A

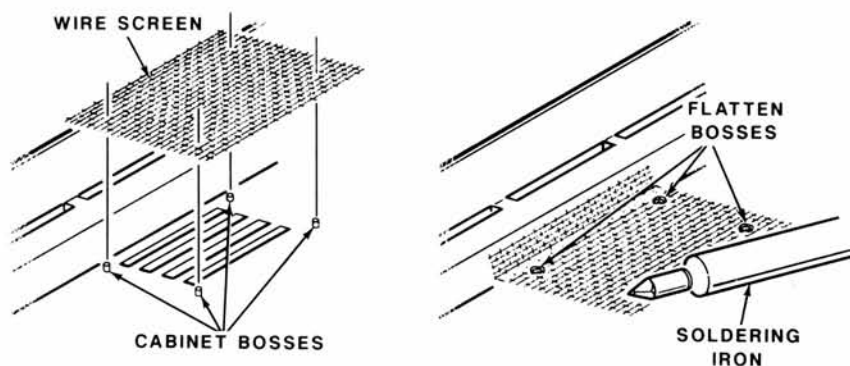

Detail 4-1B

- () Refer to Detail 4-1B and mount a wire screen to the inside of the cabinet bottom at AC. Install the screen with the holes over the cabinet bosses, and then use your soldering iron to flatten the bosses over the holes to hold the screen in place.
 - () Similarly, mount a wire screen at AD.
 - () Set the cabinet bottom aside.
 - () Position the back panel with the bottom flange as shown in the Pictorial.
 - () R1: Refer to inset drawing #1 on the Pictorial and cut off the locating tab from the 20 k Ω control. Then mount control at R1 with the hardware supplied with the control.
 - () Turn control R1 fully counterclockwise until it clicks (if it is not already there). Refer to inset drawing #2 and install the knob on the control shaft so the pointer is at the 7 o'clock position; then tighten the setscrew.
- NOTE: In the following two steps, make sure you tighten the connector hardware securely.
- () J2: Mount a female BNC connector at J2 with a large solder lug, the lockwasher and nut supplied with the connector. Position the lockwasher as shown with the solder lug straight up. When you have tightened the nut securely, bend the solder lug down 90°.
 - () J3: Mount a second female BNC connector at J3 with a large solder lug. Also bend this solder lug down 90°.
 - () J1: Mount the power socket at J1 with two M2.6 \times 6 mm screws. Position the socket with the lugs up as shown.

Heathkit®

- () Refer to Detail 4-1C, measure 8-1/2" from the end of the smooth line cord lead, and install the strain relief on the line cord as shown. Then insert the end of the line cord through hole C and insert the strain relief into the hole.

NOTE: If you are not going to install the GCA-1000-1 Accessory in your unit, perform the next step. Otherwise, skip the step.

- () Mount the rectangular plug at hole X6.

- () Mount the back panel assembly to the cabinet bottom with two M3 × 6 mm flat head screws. Position the panel with the bottom flange as shown.

NOTE: If you are installing the GCA-1000-1 Accessory in your unit, proceed to "Optional RS-232C Connector Installation," otherwise, skip those steps and proceed to "Back Panel Wiring."

OPTIONAL RS-232C CONNECTOR INSTALLATION

NOTE: Use the hardware supplied with the GCA-1000-1 RS-232C Output Accessory to mount the connector in the next step.

- () X6: Refer to Detail 4-1D and position the pin 1 end of the RS-232C connector you assembled earlier as shown. Then mount the connector to the back panel with two 4-40 × 3/16" hex spacers, two #4 lockwashers, and two 4-40 nuts. NOTE: You will connect the 3-wire cable coming from the connector later.

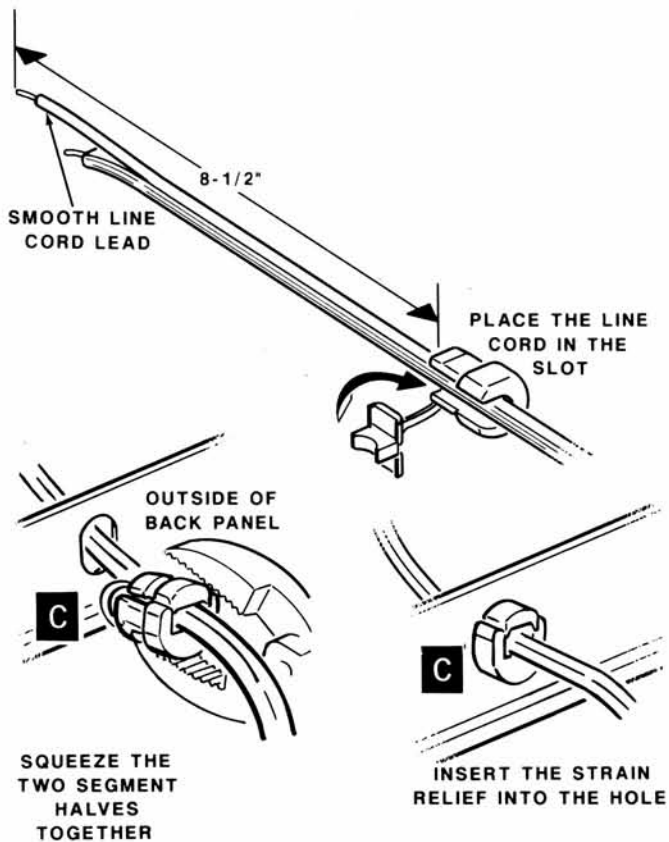

Detail 4-1C

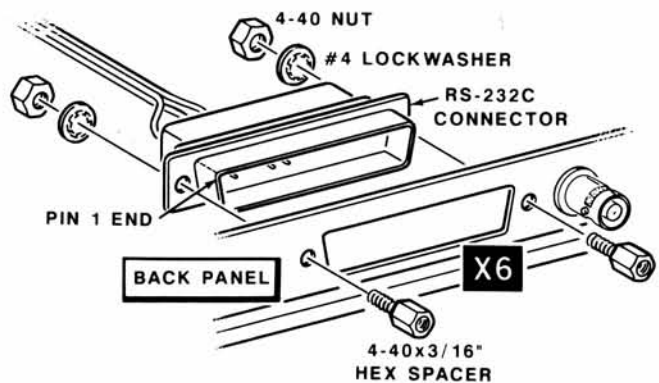

Detail 4-1D

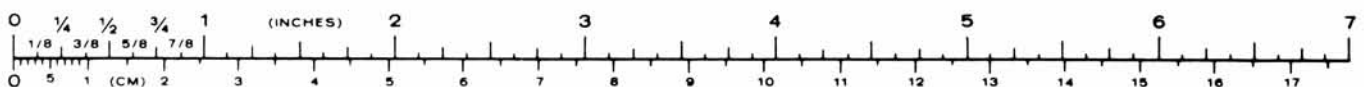

BACK PANEL WIRING

Refer to Pictorial 4-2 (Illustration Booklet, Page 7) for the following steps.

NOTES:

In the following steps, (NS) means not to solder because other wires will be added later. "S-" with a number following it, such as (S-3), means to solder the connection. The number three tells you that there are three wires and/or leads in the connection.

Whenever you connect a wire or lead to a circuit board or control lug, always cut off the excess lead or wire lengths after you solder the connection.

- () Position the main circuit board inside the cabinet bottom so that you can connect the line cord in the next step.
- () Refer to Detail 4-2A and connect the ribbed line cord lead to main circuit board hole A (S-1) and the smooth lead to hole B (S-1).
- () Lay the main circuit board loosely inside the cabinet bottom and route the line cord as shown in Pictorial 4-2.

Connect the following wires coming from the main circuit board to the back panel as follows.

- () Red wire coming from hole K to power socket J1 lug 1 (S-1).

- () Brown wire coming from hole J through lug 2 of power socket J1 (S-2) to lug 3 (NS). NOTE: The connection at lug 2 counts as two connections, one entering and one leaving.
- () Remove a 2" orange wire from the 8-wire ribbon cable and prepare the ends.
- () Connect one end of the orange wire to J1 lug 3 (S-2) and the other end to solder lug J3 (NS).
- () Connect the coaxial cable inner lead coming from hole P to the center pin of BNC connector J2 (S-1), and connect the shield lead coming from hole Q to the solder lug at BNC connector J2 (NS).
- () Use a small knife or sandpaper to remove any varnish that may be on power transformer lug AA.
- () Remove 3/8" of insulation from both ends of a 3" black stranded wire.
- () Crimp and solder an M3 solder lug onto one end of the prepared wire.
- () Connect the other end of the prepared black wire to the solder lug at BNC connector J2 (S-2).

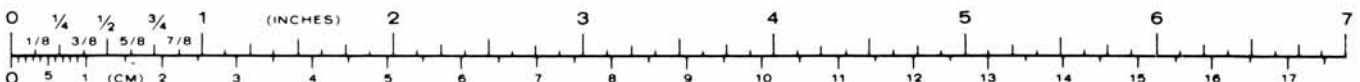

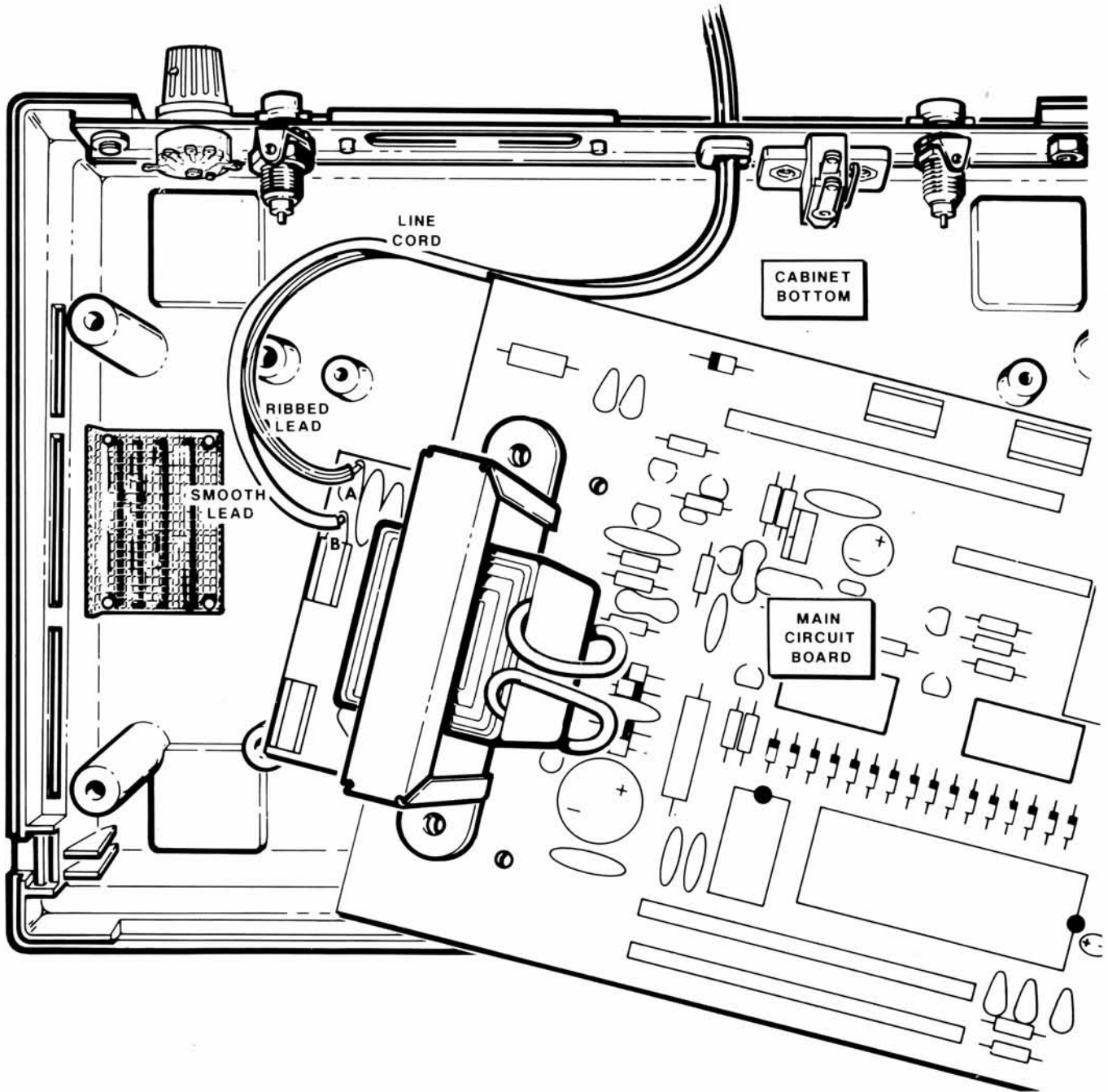

Detail 4-2A

Refer to Detail 4-2B (Illustration Booklet, Page 7) for the following steps.

- () Prepare the ends of a 2" blue, violet, and gray 3-wire cable from the section you set aside earlier. Then set the 3-wire cable aside.
- () Cut a 4" orange, yellow, and green 3-wire cable from the section you set aside earlier. Remove and discard the orange wire.
- () Prepare the ends of the 4" yellow and green 2-wire cable. Then set the cable aside.
- () Prepare the ends of a 2-1/2" 50 Ω coaxial cable.

Refer to Detail 4-2C for the following steps.

- () Refer to inset drawing #1 of Part A and crimp and solder spring connectors on the inner and shield leads at the 1/8" prepared ends of the 2-1/2" 50 Ω coaxial cable.

Refer to Part A again and insert the spring connectors on the lead ends of the coaxial cable into a 3-hole connector as follows. Position the 3-hole connector with the slots up and the spring connectors with the locking tabs up. Insert the spring connectors into the holes until you hear a faint latching "click."

- () Shield lead into hole 1.
- () Center lead into hole 2.

NOTE: If it ever becomes necessary to remove a wire from a 3-hole connector, use a small-bladed screwdriver as shown in inset drawing #2 of the Detail.

Set this cable assembly aside.

- () Refer to Part B of the detail and crimp and solder spring connectors on the 1/8" prepared ends of the 4" yellow and green 2-wire cable.

Refer to Part B and insert the spring connector on the wire ends into a 3-hole connector as follows. Position the 3-hole connector with the slots up and the spring connectors with the locking tabs up.

- () Yellow wire into hole 2.
- () Green wire into hole 3.

Set the cable assembly aside.

- () Refer to Part C of the detail and crimp and solder spring connectors on the 1/8" prepared ends of the 2" blue, violet, and gray 3-wire cable.

Refer to Part C and insert the spring connectors on the wire ends into a 3-hole connector as follows. Position the 3-hole connector with the slots up and the spring connectors with the locking tabs up as before.

- () Blue wire into hole 1.
- () Violet wire into hole 2.
- () Gray wire into hole 3.

Set the cable assembly aside.



PART A

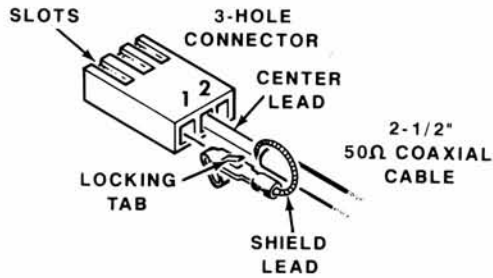

PART B

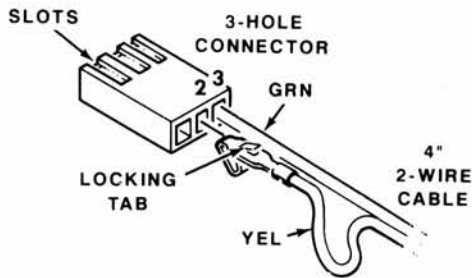

PART C

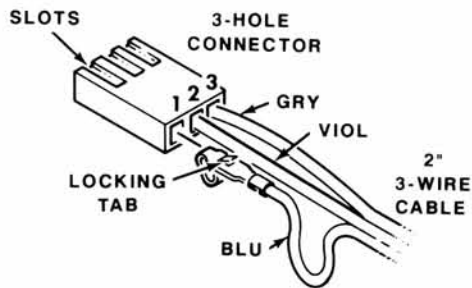

INSET #1

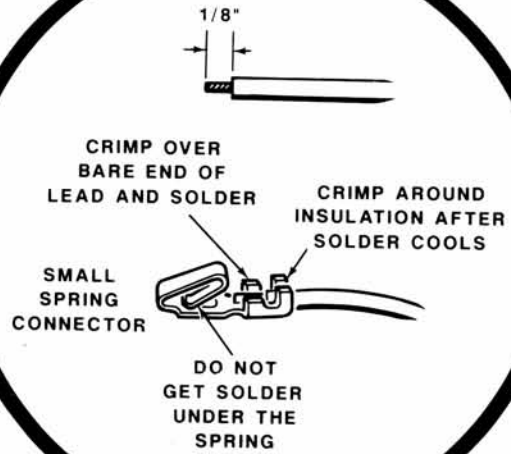

INSET #2

1. TO REMOVE A WIRE FROM A CONNECTOR, INSERT A SMALL-BLADED SCREWDRIVER INTO THE SLOT AND PUSH DOWN ON THE TAB.

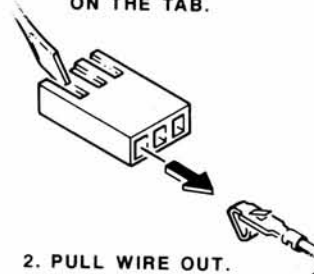

Detail 4-2C

Refer to Pictorial 4-2 for the following steps.

Connect the free wire ends of the yellow and green 2-wire cable assembly to control R1 as follows. Refer to the appropriate drawing in the Pictorial or the inset for your control wiring.

- () Yellow wire to lug 5 (S-1).
- () Green wire to lug 4 (S-1).

Connect the free wire ends of the blue, violet, and gray 3-wire cable assembly to control R1 as follows:

- () Blue wire to lug 1 (S-1).
- () Violet wire to lug 2 (S-1).
- () Gray wire to lug 3 (S-1).

Connect the free lead ends of the 50 Ω coaxial cable assembly to BNC connector J3 as follows:

- () Center lead to the center pin (S-1).
- () Shield lead to the solder lug (S-2).
- () Align the main circuit board mounting holes with the cabinet bottom mounting holes at AA, AB and AE. Install an M3 \times 8 mm self-tapping screw at AE. Then mount the power transformer at AA and AB with two M3 \times 10 mm screws, two M3 flat washers, and two M3 lockwashers. Install the lockwashers on top of the flat washers. Be sure to mount the solder lug on the free end of the black wire coming from the BNC connector under the lockwasher at AA.

Refer to Pictorial 4-3 (Illustration Booklet, Page 8) for the following steps.

- () If it has not already been done, remove any shipping material from the receiver circuit board. Be careful not to disturb any of the preset controls.

- () Mount the short side of the angle bracket (not the antenna bracket) to the component side of the receiver circuit board with a M3 \times 6 mm screw, an M3 lockwasher, and an M3 nut as shown.
- () Mount the slotted side of the antenna bracket to the receiver circuit board with a M3 \times 6 mm screw, an M3 lockwasher, and an M3 nut as shown. Pull the bracket down as far as it will go in its slot before you tighten the screw.
- () If it is installed, route the 3-wire cable coming from the RS-232C connector around the side of connector P201 as shown.
- () Insert receiver circuit board socket X301 onto the pins of main circuit board plug P201. Make sure none of the plug pins are bent. Bend the back panel cable assemblies back out of the way and make sure the line cord is routed around the back panel and under the end of the receiver circuit board.
- () Mount the receiver circuit board angle bracket at hole AH with an M3 \times 8 mm self-tapping screw and the antenna bracket at hole AJ with an M3 \times 10 screw. Install the antenna bracket screw from the bottom of the cabinet.
- () Position 3-hole connector X2 on the end of the blue, violet, and gray 3-wire cable coming from the Volume control with the slots facing up, and insert the connector onto the receiver circuit board plug P302.
- () Position 3-hole connector X3, on the end of the yellow and green 2-wire cable coming from the Volume control, with the slots facing up. Insert the connector onto the receiver circuit board plug P303.

Heathkit®

- () Insert 3-hole connector X1, on the end of the 50 Ω coaxial cable coming from BNC connector J3, onto receiver circuit board plug P301. Install this connector either way. Position the cable downward into the cabinet bottom.

Refer to Pictorial 4-4 (Illustration Booklet, Page 9) for the following steps.

- () Check to make sure that the rows of pins at main circuit board plugs P202 and P203 are straight.
- () Install the 25-hole connector on the display circuit board over main circuit board plug P203. Then secure the circuit board angle brackets to the cabinet at AK and AL with two M3 \times 8 mm self-tapping screws. Loosen the hardware and position the brackets as necessary.

- () Install the 25-hole connector on the tone decoder circuit board over main circuit board plug P202 and secure it to the display circuit board with two round plastic spacers, two M3.5 \times 14 mm screws, and two M3.5 nuts.

- () If it is installed, plug 4-hole connector X5 on the end of the blue, violet, and gray 3-wire cable coming from RS-232C connector X6 to plug P401 on the tone decoder circuit board.

- () S101: Refer to Detail 4-4A and install the slide switch into its cabinet bottom compartment so the edge of the display circuit board is between pins 1, 2, 4, and 5. With the switch in place, solder pins 1 and 4 to the front circuit board foil and pins 2 and 5 to the back foil. NOTE: If necessary, remove the circuit board to solder pins 2 and 5.

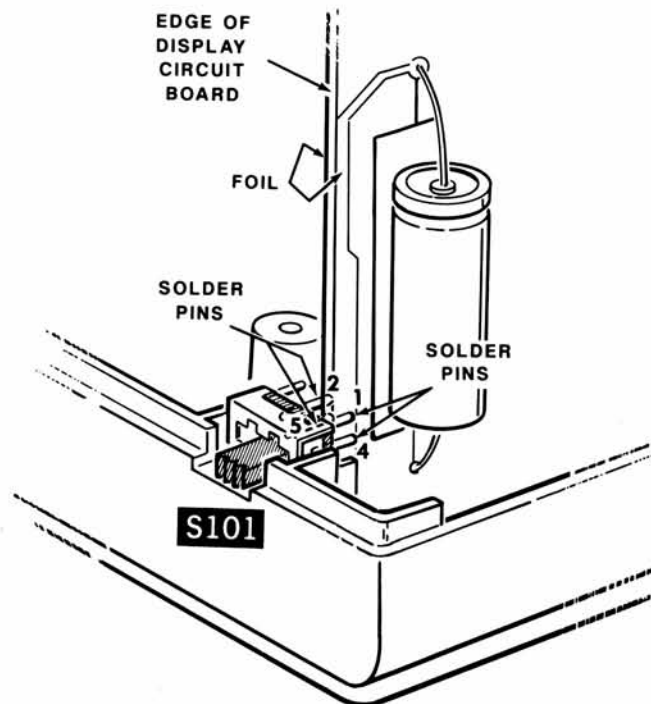

Detail 4-4A

Refer to Pictorial 4-5 for the following steps.

- () Place the unit on its side as shown. Remove the backing paper from each foot and mount them at the four recessed locations.
- () Remove the backing from the GC-1000-H Model label and press the label onto the cabinet bottom at the indicated location.
- () Remove the backing from the FCC label and press the label onto the cabinet bottom at the indicated location.
- () If you installed the Accessory, remove the backing from the GCA-1000-1 blue and white label and press the label onto the cabinet bottom as indicated.
- () Remove the backing from the FCC label and press the label onto the cabinet bottom at the indicated location.
- () Remove the backing from the function label and press the label onto the cabinet bottom at the indicated location.
- () Set the assembly aside.

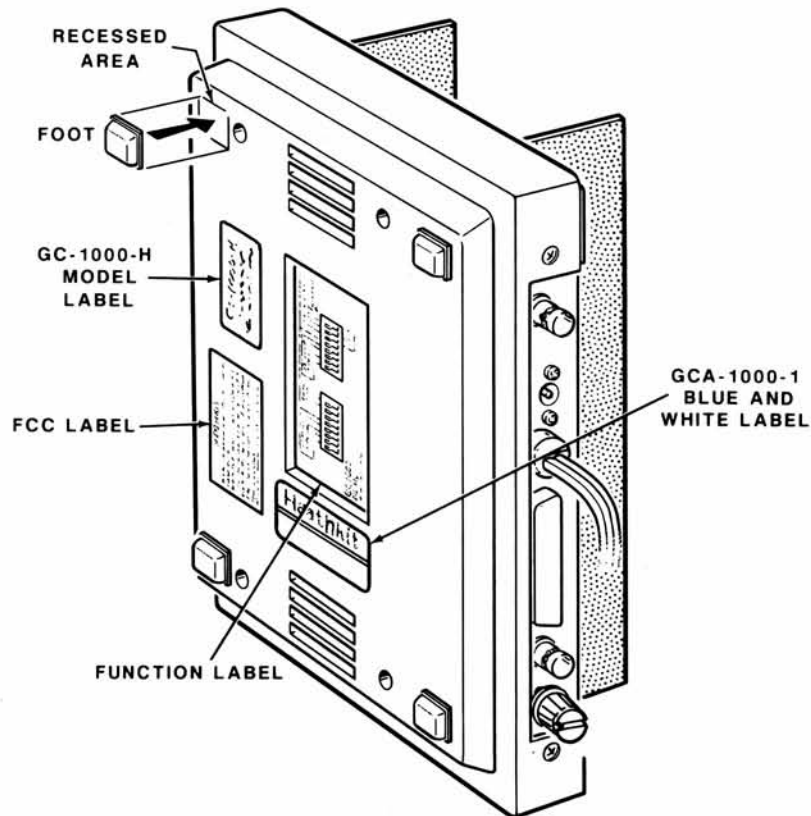

PICTORIAL 4-5



Heathkit®

Refer to Pictorial 4-6 (Illustration Booklet, Page 9) for the following steps.

- () Position the cabinet top as shown.
- () If you installed the Accessory, remove the backing from the GCA-1000-1 function label and press the label onto the inside of the cabinet at the indicated location.
- () Refer to Detail 4-6A and separate and prepare the ends of the 10" brown and red 2-wire cable as shown.
- () Refer to inset drawing #1 of Detail 4-6A and crimp and solder spring connectors at the 1/8" end of the brown and red wires.

Refer to inset drawing #2 of Detail 4-6A and insert the spring connectors into the remaining 3-hole connector as follows. Position the 3-hole connector with the slots facing up and the spring connectors with the locking tabs up.

- () Red wire into hole 2.
- () Brown wire into hole 3.

Refer to the Pictorial and connect the free end of the brown and red 2-wire cable to the speaker terminals as follows:

- () Red wire to the positive (+) marked terminal (S-1).
- () Brown wire to the negative (-) marked terminal (S-1).
- () Mount the speaker to the inside of the cabinet top with four clamps and four M3 × 6 mm self-tapping screws. Position the speaker with the lugs as shown.
- () Remove the backing from the speaker grille and position the grille with the wide space as shown. Line up the adhesive-free areas on the grille with the slots on the cabinet top, and then press the grille into place. NOTE: If your speaker grille has tabs on it, press them through the cutouts on the outside of the cabinet top and bend them over against the inside.

NOTE: If you intend to use an external antenna with your Clock, perform the next step. Otherwise, skip the step.

- () Press the round plastic plug into the cabinet top antenna mounting hole.
- () Set the cabinet top aside.

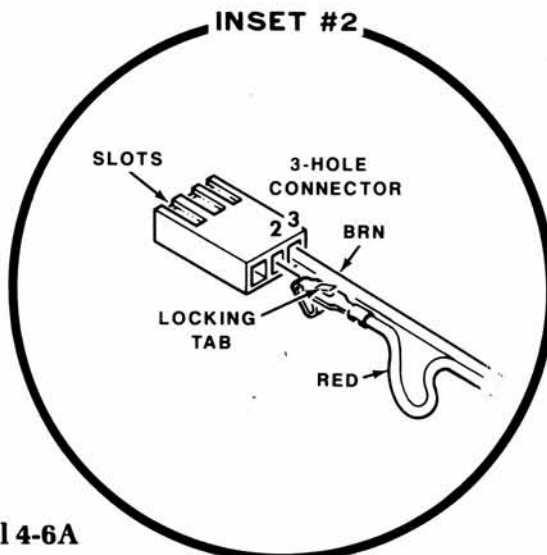
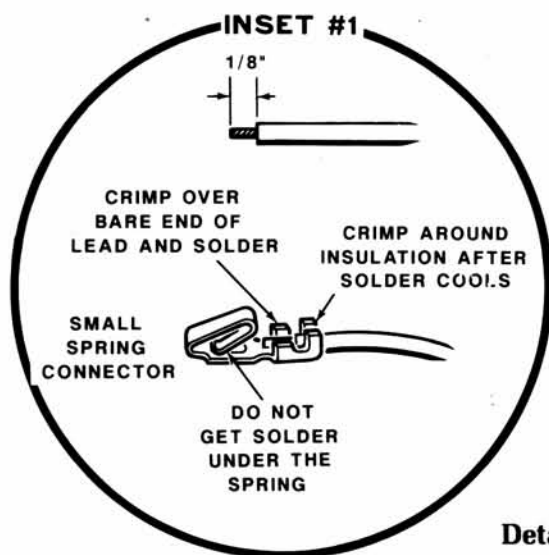
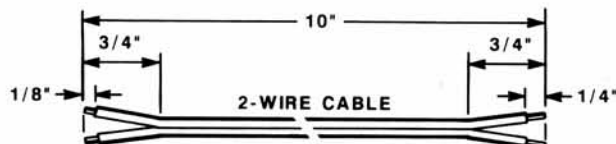

Detail 4-6A

POWER CABLE ASSEMBLY

Refer to Pictorial 4-7 for the following steps.

- () Refer to Detail 4-7A and remove 1-3/4" of outer insulation from either end of the 2-wire cable and prepare the wire ends. NOTE: Be careful not to cut into the inner wire insulation when you remove the outer insulation.

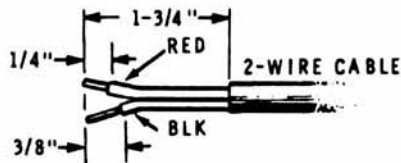

Detail 4-7A

- () Unscrew the cap from the power plug and slide the cap over the prepared end of the cable with the threaded end towards the prepared wires.
- () Connect the red wire to the inner lug of the power plug (S-1) and the black wire to the outer lug (S-1).
- () Screw the cap back onto the power plug.

If you intend to use a battery to operate your Most Accurate Clock, prepare the remaining cable end according to the type of battery you use. The amount of outer insulation you will remove at the other end of the power cable will depend on the distance between the battery's terminals.

EXTERNAL ANTENNA CABLE ASSEMBLY

Use the following procedure to prepare the coaxial RG-174 external antenna cable.

Refer to Detail 4-7B and:

1. () Carefully remove 1/2" of outer insulation from the RG-174 coaxial cable at one end.



Detail 4-7B

Refer to Detail 4-7C and:

1. () Push the braided shield wires back over the outer insulation.
2. () Remove 1/8" of insulation from the end of the inner lead. Then apply a small amount of solder to the bare wire end of the center lead.

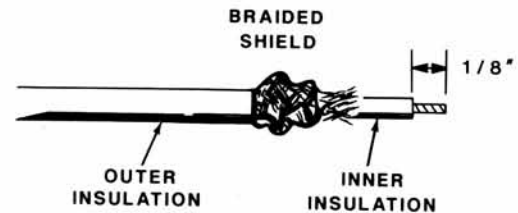

Detail 4-7C



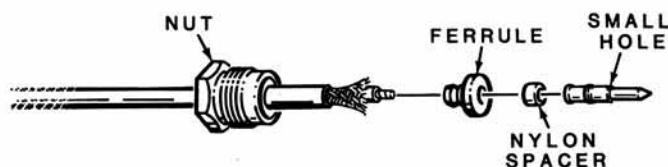

Detail 4-7D

Refer to Detail 4-7D and:

1. () Pull the braided shield wires back over the inner lead to their original position.
2. () Slide the BNC nut over the shield wires onto the end of the cable.
3. () Push the braided shield wires back enough to expose the end of the inner lead.
4. () Push the BNC pin (this includes the ferrule and the nylon spacer) onto the end of the inner lead. Solder the pin to the inner lead. To do this, position the pin so the small hole faces upward. Then hold your soldering iron against the under side of the pin and apply a small amount of solder into the small hole. Do not allow solder to accumulate on the outside of the pin.

Refer to Detail 4-7E and:

1. () Pull the braided shield wires over the ferrule. Then cut off the shield wires that extend beyond the sides of the ferrule.
2. () Push the connector onto the pin until it seats against the nylon spacer.
3. () Grasp the connector with long-nosed pliers. Slide the nut onto the connector and turn the nut until it is tight.

The preparation of the free end of the antenna cable will depend upon your antenna.

This completes the "Step-By-Step Assembly." Proceed to "Initial Tests And Calibration."

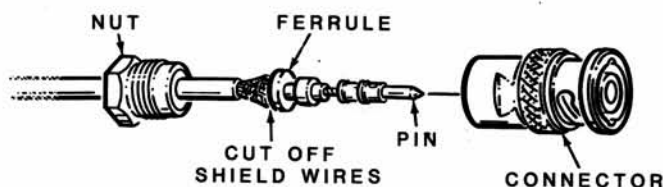

Detail 4-7E

INITIAL TESTS AND CALIBRATION

PRIMARY WIRING CHECKS

OHMMETER CHECKS

NOTE: If an ohmmeter is available, perform the following steps before you apply power to your unit. If you do not get the proper readings using an ohmmeter, refer directly to the "In Case Of Difficulty" section on Page 76. Do not apply power to the unit if you do not obtain the correct readings. If an ohmmeter is not available, skip this section and proceed to "Calibration."

Refer to Pictorial 5-1 (Illustration Booklet, Page 10) for the following steps.

- () Connect the negative (-) ohmmeter lead to one of the back panel solder lugs.

- () Set the ohmmeter to measure 80 Ω .
- () With the positive (+) ohmmeter lead, first measure one line cord plug prong and then the other. In both cases the meter should indicate infinity (∞).
- () Connect the negative ohmmeter lead to one line cord plug prong and the positive lead to the other prong. The meter should indicate approximately 15 Ω .

This completes the "Primary Wiring Checks." Proceed to "Calibration."

CALIBRATION

Refer to Pictorial 5-1 (Illustration Booklet, Page 10) for the following steps.

SETUP

- () If it is not already there, turn the VOLUME control (located on the back panel) fully counterclockwise until it clicks (off).
- () Turn the unit on its back and slide all of the dip switches at S201 and S202 to their off (down) position. Then place the unit back to its normal position.
- () Place the DISPLAY switch (S101) on the left front corner to its on (forward) position.
- () Place the TEST switch (S501) on the test circuit board to the TEST position.
- () Refer to inset drawing #1 and cut and form the leads of the 33 k Ω (org-org-org) resistor as shown.
- () Insert the prepared 33 k Ω resistor leads into connector pins TP1 and TP2 on the tone decoder circuit board.

Although there are five calibration modes, you will only use three of them to calibrate your Clock. You will not use Modes 4 and 5, they are set automatically.

You can make mode function changes by pressing the STOP switch (S502). The current mode function (1, 2, 3, 4, or 5) is indicated by the last 7-segment display to the right.

In Mode #1, you will check the digits and LEDs for operation. In Mode #2 you will adjust the 1000 Hz tone decoder if you intend to use WWV as a standard. In Mode #3, you will adjust the 1200 Hz tone decoder if you intend to use WWVH as a standard.

MODE #1

Checking The Digits And LEDs

- () Plug the line cord into a 120 VAC, 50/60 Hz outlet (or into a 240 VAC outlet if it is wired for 240 VAC). NOTE: If you intend to use an external 12 VDC supply, connect it to the unit using the cable you assembled earlier. Refer to inset drawing #2. Connect the red wire at the free end of the cable to the positive (+) battery terminal and the black lead to the negative (-) terminal.
- () The AM LED may or may not be on, or it may flash. If it flashes, the PM LED will also flash.
- () The Data LED should be off.
- () The LED display should read: 88 88 88. 1.
- () The remaining LEDs should be on.

NOTE: If you intend to receive station WWV, perform the following "1000 Hz Tone Decoder Adjustments" in Mode #2. If you intend to receive WWVH, proceed to "1200 Hz Tone Decoder Adjustments" under "Mode #3."

MODE #2

1000 Hz Tone Decoder Adjustments

- () Press the STOP switch (S502) on the test circuit board for 1/2 second. The AM LED may or may not be on, or it may flash. All other LEDs should be off. The display should indicate 1 0 0 0 . 2. If the display shows something other than this, the unit is in another mode of operation. To change modes, slide the TEST switch on the test circuit board back to Normal and then to TEST again, and press the STOP switch until the proper display is indicated.

- () Turn the 1000 Hz control (R444) on the tone decoder circuit board fully clockwise.
- () Turn the same control fully counterclockwise.
- () Turn the 1000 Hz control on the tone decoder circuit board **slowly** counterclockwise until the AM LED begins to glow. Then mark the position of the control marker with a pencil.
- () Turn the same control fully counterclockwise.
- () Turn the same control **slowly** clockwise until the AM LED begins to glow again. Mark the control marker location with a pencil.
- () Center the control marker between the two pencil mark positions.
- () Turn the same control fully counterclockwise.
- () Turn the same control **slowly** clockwise until the AM LED begins to glow again. Mark the control marker location with a pencil.
- () Center the control marker between the two pencil mark positions.

Proceed to "100 Hz Tone Decoder Adjustments."

MODE #3

1200 Hz Tone Decoder Adjustments

- () Briefly press the STOP switch (SW502) on the test circuit board for 1/2 second. The AM LED may or may not be on or it may flash. All other LEDs should be off. The display should indicate **1 2 0 0 . 3**. If the display shows some display other than this, the unit is in another mode of operation. To change modes, slide the TEST switch back to NORMAl and then to TEST again, and press the STOP switch until the proper display is indicated.
- () Make sure that capacitors C415 and C416 are .0082 μ F and that resistor R443 is 7.32 k Ω on the 1200 Hz tone decoder circuit board.
- () Turn the 1000 Hz control (R444) on the tone decoder circuit board fully clockwise.
- () Turn the 1000 Hz control on the tone decoder circuit board **slowly** counterclockwise until the AM LED begins to glow. Then mark the position of the control marker with a pencil.
- () Turn the same control fully counterclockwise.
- () Turn the same control **slowly** clockwise until the AM LED begins to glow again. Mark the control marker location with a pencil.
- () Center the control marker between the two pencil mark positions.
- () Turn the 100 Hz control (R434) on the tone decoder circuit board fully clockwise.
- () Turn the 100 Hz control on the tone decoder circuit board **slowly** counterclockwise until the DATA LED begins to glow. Then mark the position of the control marker with a pencil.
- () Turn the same control fully counterclockwise.
- () Turn the same control **slowly** clockwise until the DATA LED begins to glow again. Mark the control marker location with a pencil.
- () Center the control marker between the two pencil mark positions.
- () Remove the 33 k Ω resistor from TP1 and TP2 on the tone decoder circuit board (the DATA LED may or may not go out). Tape the resistor on this page in case you should need it again.
- () In order to set your Most Accurate Clock to the correct time in your particular "time zone," refer to "Dip Switches — SW201 & SW202" on Page 74 in the Operation section. Once you have set the dip switches properly, return to this section.
- () Unplug the line cord to blank the display and remove the random time from memory.

100 Hz Tone Decoder Adjustments

Heathkit®

NOTE: There are two modes of Volume operation: automatic and normal. With the VOLUME control turned on in the automatic mode, the microprocessor automatically turns the audio on for a minimum of ten minutes in sequence with the Hi Spec light whenever the Clock is synchronized by the WWV signals. The normal mode defeats the automatic function so you can manually turn the signals on or off. Both functions allow you to vary the volume level as desired.

Your Clock is presently in the "normal" mode of operation. We recommend that you operate your Clock in this mode for the first few days to become familiar with its operation and the strength of the signals you can receive at various times of the day and night. If you wish to change to the "automatic" mode of operation after that, perform the following step.

- () For automatic control of the audio signals, position 3-hole connector X3, on the end of the yellow and green 2-wire cable coming from the VOLUME control, over receiver circuit board plug P303 with the slots facing down.

NOTE: If you have successfully completed the calibration and you encountered no difficulties, then the display and the microprocessor are operating properly. Check the audio for the WWV signal. If you are receiving the signals from the station, you can be assured that the Clock is operating properly. If you do not receive a signal, the Clock may be operating properly but you may need a better antenna. If you still do not receive a signal using an external antenna, contact "Technical Assistance" at (616) 982-3296.

This completes the "Initial Test And Calibration."
Proceed to "Final Assembly."

FINAL ASSEMBLY

Refer to Pictorial 6-1 for the following steps.

- () Position the cabinet bottom and top as shown.
- () Carefully mount the window in the cabinet top so the tabs lock into place.
- () Insert speaker connector X4 over receiver circuit board plug P304 with the connector slots as shown.
- () Check to make sure that none of the LEDs are bent over. Then mount the cabinet top onto the cabinet bottom with four M3.5 × 12 mm self-tapping screws. Make sure the bottom lip of the window fits inside the cabinet bottom.
- () If you do not intend to use an external antenna, mount the antenna to the antenna bracket through the hole in the cabinet top. Twist the antenna onto the bracket screw until it is just snug.

This completes the "Final Assembly."

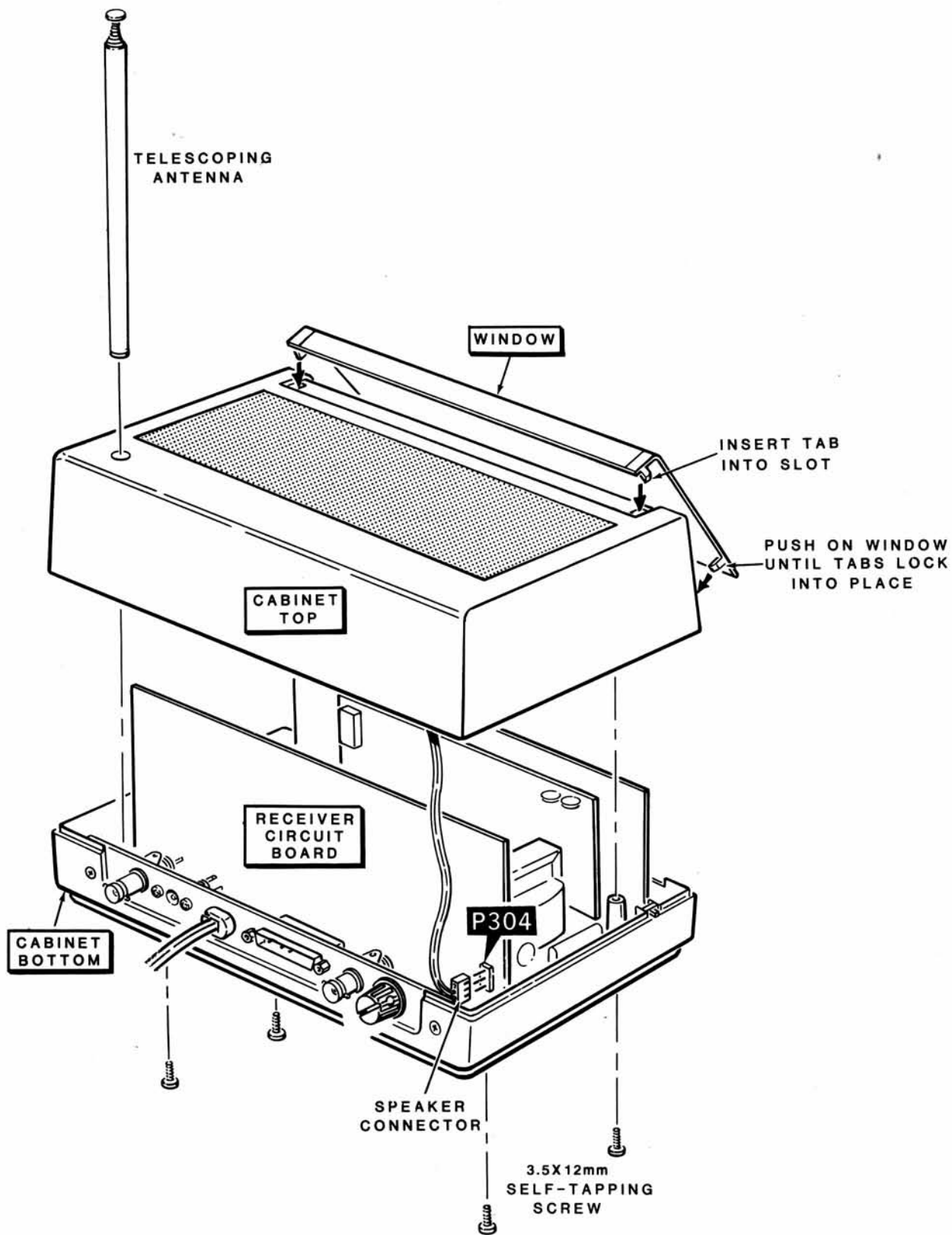

PICTORIAL 6-1

THEORY OF OPERATION

NOTE: The following information was taken from the National Bureau of Standards Time and Frequency Users' Manual, NBS Special Publication 559. A copy of this Manual may be purchased from:

U.S. Department of Commerce
National Bureau of Standards
Washington, D.C. 20234

Since your GC-1000 Most Accurate Clock uses the signals transmitted by station WWV or WWVH (depending upon your location) for its accuracy, the following section is intended to give you a short explanation of why these stations exist, what they accomplish, and how they relate to the operation of your unit.

STANDARDS

A standard is the ultimate unit used for comparison. In the United States, the National Bureau of Standards (NBS) is responsible for maintaining and distributing all the standards of physical measurement.

There are four independent standards, or base units, of measurement: length, mass, time, and temperature. All of these units are called "independent" because all other measurements are derived from them. The important quantity involved here is that of time interval (the length of time between two events). This time interval can be controlled and measured with the smallest percentage error of any physical quantity.

Time Interval (Frequency)

Your GC-1000 Most Accurate Clock counts time intervals. It uses the time between ticks or tones on NBS station WWV, Colorado, or WWVH, Hawaii to make time interval calibrations to obtain seconds, minutes, and hour information.

Time Standard

Time of day, as we most commonly refer to it, is usually in its brief form of hours, minutes, and seconds. However, a more complete statement of time of day, would include the day of the week, the month, and the year.

In addition to generating and distributing standard frequency and time intervals, the NBS also broadcasts the complete time of day via its radio stations WWV, WWVH (Hawaii). The role of these stations is to provide an accurate standard of frequency and time interval to users and enforcement agencies alike.

You may have heard the term "standard time" used in conjunction with time "zones." The NBS adjusts its source of time periodically to agree with the clocks in other countries (different time zones).

The NBS time standard for frequency and time interval is located in Boulder, Colorado. It carries the designation NBS-6 because it is the sixth in a series of atomic oscillators built and maintained by the NBS to provide a reference for frequency and time intervals in the United States. NBS-6 is referred to as the "master" or "primary" clock and is used to calibrate other oscillators, or "secondary" clocks, which operate the time scale.

The term "calibration" carries with it a measure of the accuracy with which the calibration was performed. Since your GC-1000 uses station WWV (or WWVH) as a calibration standard, it is very accurate.

TIME CODES

In this section, we will discuss the timing codes which are transmitted by station WWV (and WWVH) and how they control the operation of your Most Accurate Clock.

The time code is a series of pulses, usually in binary code, where a set of pulses represents one digit. If a 4 is sent, for example, (meaning 4 hours, 4 minutes, or 4 seconds), the location of a particular binary digit in the code tells you its meaning; that is, whether it is an hour, minute, or second. Depending on its application, the code can be sent as a direct current (DC) level shift (high or low), as modulated pulses on a carrier, or as tones where one frequency of tone represents a binary "1" and an alternate tone represents binary "0." This is known as a "serial code." Interspersed among the time bits are "position locators," which allow your GC-1000 to recognize what the following bit is going to mean.

Pictorial 7-1 (Illustration Booklet, Page 11) shows a typical Inter-Range Instrumentation Group (IRIG) time code format which differs very slightly from the WWV time codes that will be shown later in another Pictorial.

Accuracy of received time codes depends on several factors. First, you have to account for the propagation path delay. For example, a user who is 1000

miles from the transmitter experiences a delay of about 5 microseconds per mile. This works out to be a 5 milliseconds time error. To this, we must add the delay through the receiver. A typical receiver delay might be one-half millisecond. So a user can experience a delay of several milliseconds, depending on his location.

TIME SCALES

A time scale is a system of assigning dates to events or counting pendulum swings. The apparent motion of the sun in the sky is called "astronomical time." Today, we have "atomic time," where an atomic oscillator is the pendulum.

Solar time is based on the earth's rotation around the sun. The earth is the flywheel and has a period of 24 hours. However, the earth's rotation around the sun is not perfectly circular, (it slows down and speeds up), depending upon its distance from the sun. Today, we have a system called UT1 which corrects for this "wobble" of the earth's axis and irregular path around the sun. It is the true navigator's scale related to the earth's angular position.

Prior to 1972, most standard frequency radio broadcasts were based on a time scale called "Coordinated Universal Time (UTC)." The rate of the UTC clock was controlled by atomic oscillators so it would be as uniform as possible. They had to be corrected each year to match the forthcoming earth rotational rate. However, the earth's rotational rate could not be accurately predicted, so the UTC would get out of step with the earth's time. They had to apply a correction change, but were unsure of how much.

The new UTC system eliminates the need for this change by the introduction of "leap seconds." Since it was decided to leave the atomic clocks at the atomic rate with zero offset, the clocks gradually got out of step with the day. Just as a leap year was added to the calendar to keep in step with the seasons, now the leap second adds (positive) or subtracts (negative) a second from a particular minute on the clock to keep it in step. Leap second corrections occur on June 30th or December 31st.

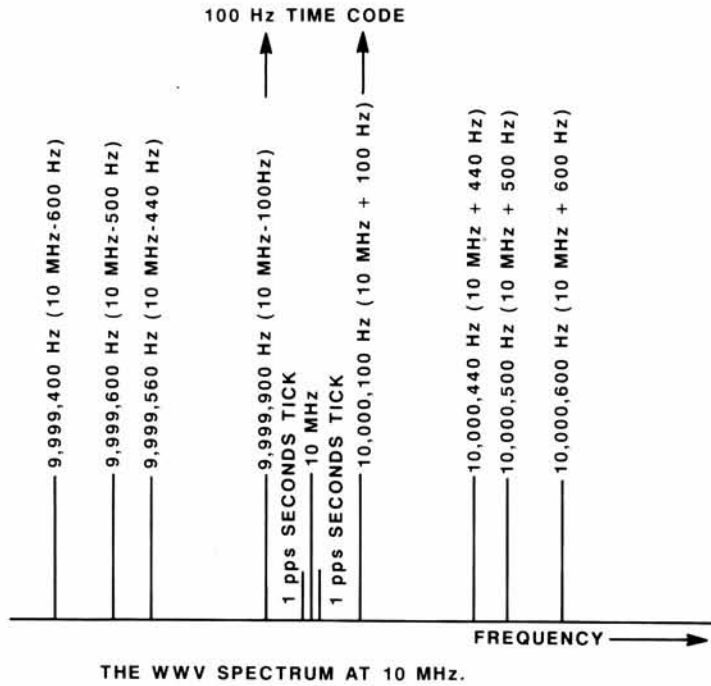

PICTORIAL 7-2

TIME ZONES

All standard time and frequency stations broadcast Coordinated Universal Time, which is referenced to the Greenwich meridian. However, scientists may wish to have a uniform time scale (UTC), while navigators require a clock tied to the earth's position (UT1), which is non-uniform. Therefore, corrections must be made to correct UTC to UT1. These corrections are made with the Most Accurate Clock's UTC 1 or UTC (GMT) dip switches.

Now that you know where the code pulses are and how they are sent, what do they say? First, they follow a specific format. It is a modified IRIG-H format similar to the one shown earlier in Pictorial 7-1. After suitable identifiers are sent, the bits that make up the units, tens, and hundreds for minutes, hours, and days are sent sequentially.

Certain pulses in succession comprise binary-coded groups which represent numbers. The binary groups and their basic decimal equivalents are shown in the table of Pictorial 7-3.

WWV/WWVH TIME CODE FORMAT

Among the several tones, ticks, and voice signals offered on WWV/WWVH, there is a time code. The GC-1000 automatically decodes this signal and displays the hour, minute, and second. Pictorial 7-2 shows the WWV/WWVH spectrum at 10 MHz. The time code is located 100 Hz from the carrier signal and is called the "subcarrier." The code pulses are sent out once every second. The other parts of the spectrum are also shown. Although the 10 MHz spectrum is shown as an example, the same distribution applies for the 5 and 15 MHz bands if you change the carrier.

WEIGHT:	BINARY GROUP				DECIMAL EQUIVALENT
	1	2	4	8	
	0	0	0	0	0
	1	0	0	0	1
	0	1	0	0	2
	1	1	0	0	3
	0	0	1	0	4
	1	0	1	0	5
	0	1	1	0	6
	1	1	1	0	7
	0	0	0	1	8
	1	0	0	1	9

PICTORIAL 7-3

In every case, the decimal equivalent of a BCD (Binary Coded Decimal) group is derived by multiplying each binary digit times the weight factor of its respective column and then adding the four products. For example, the binary sequence 1010 in the 1-2-4-8 scheme means $(1 \times 1) + (0 \times 2) + (1 \times 4) + (0 \times 8) = 5$ as shown in the table.

In the standard IRIG-H code, (Pictorial 7-4, Illustration Booklet, Page 11), a binary 0 pulse consists of exactly 20 cycles of 100 Hz amplitude modulation (200 milliseconds duration), whereas a binary 1 consists of 50 cycles of 100 Hz (500 milliseconds duration). In the WWV/WWVH broadcast format, however, all tones are suppressed for 30 ms while the seconds pulses are transmitted.

Because the tone suppression applies also to the 100 Hz subcarrier frequency, it has the effect of deleting the first 30 millisecond portion of each binary pulse in the time code. Thus, a binary 0 contains only 17 cycles of 100 Hz amplitude modulation (170 milliseconds duration) and a binary 1 contains 47 cycles of 100 Hz (470 milliseconds duration). The leading edge of every pulse coincides with a positive-going zero crossing of the 100 Hz subcarrier, but it occurs 30 milliseconds after the beginning of the second.

Within a time frame of one minute, enough pulses are transmitted to convey, in BCD language, the current minute, hour, and day of the year. Two BCD groups are needed to show the hour and the minute (00 through 23 and 00 through 59); and three groups are needed to show the day of the year (001 through 366). When representing units, tens, or hundreds, the basic 1-2-4-8 weights are simply multiplied by 1, 10, or 100 as appropriate. The coded information always refers to time at the beginning of the one-minute frame. You can determine seconds by counting pulses within the frame.

Each frame begins with a unique spacing of pulses to mark the beginning of a new minute. No 100 Hz pulse is transmitted during the first seconds space, so a hole occurs in the pulse train at that time. Because all pulses in the time code are 30 milliseconds late with respect to UTC, each minute actually begins 1030 milliseconds (or 1.03 seconds) prior to the leading edge of the first 100 Hz tone in the new frame.

For synchronization purposes, a position identifier pulse is transmitted every ten seconds. Unlike the BCD pulses, the position identifiers consist of 77 cycles of 100 Hz (770 milliseconds duration).

UT1 corrections to the nearest 0.1 second are broadcast via BCD pulses during the final ten seconds of each frame. The coded pulses which occur between the 50th and 59th seconds of each frame are called control functions. Control function #1, which occurs at 50 seconds, tells whether the UT1 correction is negative or positive. If control function #1 is a binary 0, the correction is negative; if it is a binary 1, the correction is positive. Control functions #7, #8, and #9, which occur respectively at 56, 57, and 58 seconds, specify the amount of UT1 correction.

Control function #6, which occurs at 55 seconds, is programmed as a binary 1 throughout those weeks when daylight-saving time is in effect and as a binary 0 when Standard Time is in effect.

Because signals such as those transmitted by WWV tend to fade, it is possible to lose some of the code bits. As these errors occur, any clock driven directly from a WWV receiver would display the incorrect time. This is overcome by having the GC-1000 tone decoder and microprocessor circuits detect the errors. One frame is decoded and is stored electronically as digital bits. The next frame is received and stored in another location. If the two frames do not differ by exactly one minute, an error has occurred, and the GC-1000 will not use this information to correct its time. The first data is discarded and another try is made until several successful decodes have been made. The GC-1000 requires three successful decodes before it corrects its time.

WWV/WWVH BROADCAST FORMAT

Refer to Pictorial 7-5 (Illustration Booklet, Page 12) for a chart of the two stations broadcast formats. NOTE: Station WWV uses a male voice announcement and WWVH uses a female voice announcement. If you receive both stations, the female voice announcement will precede the male voice announcement.

OPERATION

OPERATING CHARACTERISTICS

SIGNAL STRENGTH

The length of time it takes for the GC-1000 Clock to initially set and update (correct the time) itself is entirely dependent on how strong the WWV signals are. The factors which effect the WWV signals are:

- The distance from the WWV transmitter. The greater the distance, the weaker the signal strength will be.
- Weather conditions. When weather conditions are poor, the signals are usually weaker than normal.
- Winter reception is better than summer reception.
- Ionospheric conditions, the time of day, the season, and sunspot activity. These factors tend to effect the individual WWV bands. For example, the best reception generally occurs on the 5 MHz band at night, 15 MHz band during the daytime, and the 10 MHz band near dusk and dawn.
- Obstacles that block the signals. Mountains, tall buildings, and metal walls are a few examples.
- Other RF signals of sufficient strength to interfere with good reception.

Some of these factors change and can cause dramatic differences in signal strength over a time period of a few minutes to several weeks. However, fixed obstacles and long distances from the transmitter often dictate the use of an external antenna for accurate operation of your Clock.

INITIAL SETTING OF THE CLOCK

The GC-1000 Clock decodes the WWV time codes (described in the "Theory Of Operation"). This coded information contains the time, date, UTC correction factor, and daylight-saving time information. It takes one minute to decode one complete frame of data (since that is the rate at which it is sent). However, due to signal fading conditions, the use of only one frame of data could cause an erroneous time to be used to set the clock. To minimize this possibility, the GC-1000 Clock decodes and compares three frames of data. This data must agree before the time can be set. Once the time is set, the clock will continue to keep time using its own 3.6 MHz crystal oscillator as a time base.

When the WWV signal is clear and strong, the clock will typically set itself in from four to thirty minutes. Strong WWV signals are characterized by:

- Loud, clear audible tones.
- Clear voice announcements.
- The Capture LED being lit.
- A flashing Data LED (regular and rhythmic) each second.
- A rare WWV band scan.

The weaker the WWV signals are, the more the Clock will deviate from these characteristics and the longer it will take for the Clock to set itself. NOTE: From the time you first apply power to your Clock until it sets itself, you may see "ghosting" of the displays. This means that the digits will be random and dimly lit, or they may go out completely. This is normal.

UPDATING THE CLOCK

While the Clock is running, it continues to decode the WWV time code. When the Clock decodes two frames which agree with the displayed time, the Clock will update and turn the Hi Spec LED on for approximately 10 minutes. This updating will cause the displayed time to be resynchronized to the WWV time if the error is greater than .005 seconds. Otherwise, the Clock will automatically adjust (trim) its 3.6 MHz time base oscillator, and cause it to run even more accurately than before. Thus, the more

often the Clock is updated, the better its accuracy during periods of the day when the WWV signal is too weak to be used.

Generally, the Hi Spec LED will be lit more than half the time when WWV reception is strong, and will be off nearly all the time when WWV reception is weak. NOTE: If the Clock does not update itself each day, the .1 second digit may dim until the Clock updates, or until ten days have elapsed. If this occurs, it generally means that you need a better antenna system.

FUNCTIONS

Refer to Pictorial 8-1 (Illustration Booklet, Page 13) for the remaining section.

FRONT WINDOW

1. **Display Switch (S101)** — The display switch is located on the left side of the case. When you slide this switch towards the front of the case, the LED indicators and 7-digit readouts are turned on (provided the Clock has set itself). When the switch is toward the back of the case, the indicators and readouts are turned off to conserve power, (as with 12 VDC battery operation).
2. **AM/PM LED Indicators** — These indicators will illuminate only if you select the 12 hr mode of operation and once the clock has been set by WWV. They will be out in the 24 hr mode.
3. **Hrs – Mins – Secs LED Indicators** — With the TEST switch (S501) in the NORMAL position, these digits will be blank (except for the decimal point) when the clock is initially powered up, and will stay off until the clock is set by WWV signals. With the TEST switch in TEST, the digits and all the LEDs (except the Data LED) will be lit. The tenths (.1) of second digit may dim if the Clock does not update itself each day.
4. **5, 10, 15 MHz LED Indicators** — These LEDs indicate which WWV channel the receiver is tuned to. While the receiver scans to determine which channel has the best signal, each LED alternately illuminates for approximately 3 seconds (while the receiver samples this channel). When the receiver determines which channel has the best signal, it will lock on the signal for approximately 16 seconds, and the appropriate LED will stay lit to indicate the channel it is monitoring.
5. **Capture LED Indicator** — Whenever the receiver detects the WWV 1000 Hz (800 ms) tone burst, it will illuminate the capture LED indicator. If the microprocessor determines that the WWV information is unclear or missing, it will then turn off the capture LED and proceed to the channel that is the clearest and strongest. If there is no strong signal, it will scan the channels once more to the highest frequency for 16 seconds, then repeat the scan until it finds an acceptable channel. As soon as another 1000 Hz tone burst is received, the capture LED will again be illuminated.
6. **Data LED Indicator** — When WWV is being received, this LED will flash once every second (except for the first second of each minute). Each second will vary from short (binary "0"), to medium (binary "1"), to long (a 10 second marker). NOTE: This flash lags the seconds update by .2 seconds.
7. **Hi Spec LED Indicator** — This LED will illuminate for approximately 10 minutes each time the complete WWV information is received and the clock is within 10 milliseconds of the WWV time.

BACK PANEL

8. **External Antenna Connector (Ext Ant)** — This connector is used to connect the clock to an external antenna. The connector you mounted on the end of the 7' coaxial cable is inserted into the back panel socket (EXT ANT) and the other end is connected to an external antenna. You can either construct your own antenna as shown in Pictorials 8-2, 8-3, and 8-4, (Illustration Booklet, Pages 14 and 15) or purchase one of several commercially available types. A long wire antenna (GRA-72) is available from Heath Company.

Whenever you use an external antenna, be sure to use a lightning arrestor. You can purchase one from your local electronics store.

NOTE: Ham antennas are not recommended for use with the Clock since they are generally non-resonant at the proper frequencies.

9. **12 VDC Connector** — This connector is used to connect to an external 12 VDC supply. The plug that you mounted on the end of the 20' cable connects to this socket. You will need a heavy duty battery (a lead-acid type would be ideal) to operate the Clock, since it's current drain is approximately .7 ampere with the display on.
10. **Line Cord** — The line cord plugs into any standard 120 VAC, 50/60 Hz line voltage socket.
11. **RS-232C Connector** — This connector is part of the GCA-1000-1 Accessory RS-232C interface. The back panel opening is covered by a plastic plug when the accessory is not installed.
12. **Volume Control (VOL)** — With the control shaft turned fully counterclockwise (off), all audio signals to the speaker are turned off; however, the clock will continue to function. With the VOLUME control turned clockwise (on) past the off function, there are two modes of operation, depending on how you installed the plug that connects between the VOLUME control switch and the receiver circuit board.

One mode will enable the microprocessor to turn the audio on automatically for a minimum of ten minutes in sequence with the Hi Spec light whenever the clock is synchronized by the WWV signal. The other mode disables the microprocessor's automatic function and allow you to manually turn the audio on or off. Both modes allow you to manually turn the audio off, and, when on, to vary the audio signal level as desired.

13. **3.6 MHz Connector** — This output connector allows you to use the crystal controlled oscillator as a reference frequency. Any load (such as a frequency counter) at this output should be resistive and greater than 1000 Ω . The oscillator's accuracy should be approximately ± 10 ppm (parts per million) and improve during warmup and after it is updated with WWV for several days. (NOTE: Extreme temperature variations can greatly affect the frequency of the oscillator.)

DIP SWITCHES – S201 & S202

*(located through an opening on the case bottom.
Disregard the numbers on the switches.)*

14. **Time Zone** — With all five (1, 2, 4, 8, and 8) of the dip switches in the "deactivate" position, UTC (Universal Coordinated Time, originally Greenwich Mean Time – GMT) will be displayed. Refer to Pictorial 8-5 (Illustration Booklet, Page 16) to determine the number for your time zone, and then activate the appropriate switch number(s). For example, Eastern Standard Time is 5, so activate switches 1 and 4 ($1 + 4 = 5$).
15. **Channel Lockout (MHz)** — If you receive constant interference on any particular WWV channel, activate the appropriate 5, 10, or 15 MHz switch. The receiver will no longer scan that channel.

Heathkit®

16. **Propagation Delay (250 MI/unit)** — These four switches (1, 2, 4, and 8) compensate for the time it takes the WWV signal to travel from Ft. Collins, Colorado to you. Estimate the distance between Ft. Collins and your location and divide this distance by 250. Round off the result to the nearest whole number and activate the propagation delay switches which add up to the number you calculated¹
17. **Daylight S.T. (Saving Time)** — Your time display will automatically be corrected for daylight-saving time when this switch is activated.
18. **24 Hour Mode** — Activate this switch if you prefer the 24-hour format. For the 12-hour format, deactivate this switch.
19. **U.T.C. 1 Correction** — U.T.C. 1 compensates for the slight variations in the earth's movement and the GC-1000-H display corrects for it when this switch is activated. This correction factor is in .1 second increments up to ± 0.7 second. Use this function for celestial navigation. When the UTC 1 correction approaches ± 0.7 seconds from UTC time, the NBS* will activate a "leap second" to correct for the difference. If one is required, a leap second is usually scheduled to occur on June 30th or December 31st.

NOTE: If you activate UTC 1, the receiver audio and the display time may vary as much as ± 0.7 second.
20. **U.T.C. (GMT)** — With this switch activated, UTC time is displayed no matter what time zone was previously selected.

* National Bureau of Standards

IN CASE OF DIFFICULTY

This part of the Manual will help you locate and correct difficulties which might occur in your Most Accurate Clock. This information is divided into two sections. The first section, "General," contains suggestions in the following areas:

- A. Visual checks and inspection.
- B. Precautions to observe when bench testing.
- C. How to determine the area of the Clock in which the difficulty is located ("How to troubleshoot your Most Accurate Clock").
- D. Locating and correcting both the cause and effect of a difficulty ("Repairing the Most Accurate Clock").

The second section consists of a "Troubleshooting Chart." This chart calls out specific problems that may occur and lists one or more conditions or components that could cause each difficulty. The resistor R numbers, capacitor C numbers, transistor Q numbers, and diode D numbers are identified in this chart by the same numbers that are used on the Schematic Diagram. Circuit Board X-Ray Views (Illustration Booklet, Pages 18 and 19) are also provided to help you locate the component and test points.

NOTE: In an extreme case where you are unable to resolve a difficulty, refer to "Customer Service" information inside the rear cover of the Manual, or call us for technical assistance at: (616) 982-3296. Your Warranty is located inside the front cover of the Manual.

GENERAL

VISUAL CHECKS

1. About 90% of the kits that are returned for repair do not function properly due to poor connections and soldering. Therefore, you can eliminate many difficulties by a careful inspection of connections to make sure they are soldered as described in the "Soldering" section of the "Assembly Notes." Reheat any doubtful connections and be sure all the wires are soldered at places where several wires are connected.
2. Check the circuit board to be sure there are no solder bridges between adjacent connections. Remove any solder bridges by holding a clean soldering iron tip between the two points that are bridged until the solder flows down the tip of the soldering iron.
3. Be sure each transistor and any integrated circuits are in the proper location (correct part number and type number). Be sure that each transistor lead is positioned properly and has a good solder connection to the foil. Check any integrated circuits for the proper positioning and good contact of all pin connections.
4. Check capacitor values carefully. Be sure the proper part is wired into the circuit at each capacitor location.
5. Check each resistor carefully. It would be easy, for example, to install a 1200 Ω (brown-red-red) resistor where a 220 Ω (red-red-brown) resistor is called for. A resistor that is discolored, or cracked, or shows signs of bulging would indicate that it is faulty and should be replaced.
6. Be sure the correct diode is installed at each diode location, and that the banded end is positioned correctly.
7. Recheck the wiring. It is frequently helpful to have a friend check your work. Someone who is not familiar with the unit may notice something you have consistently overlooked.
8. Check all component leads connected to the circuit board. Make sure the leads do not extend through the circuit board and make contact with other connections or components.

PRECAUTIONS FOR BENCH TESTING

1. Be cautious when you test solid-state circuits. Although transistors and integrated circuits have almost unlimited life when used properly, they are much more vulnerable to damage from excessive voltage or current than other circuit components.
2. Be sure you do not short any terminals to ground when you make voltage measurements. If the probe should slip, for example, and short out a bias or voltage supply, this could cause damage to one or more transistors or diodes.
3. Do not remove transistors or any integrated circuits while the Clock is turned on, since this could damage the Clock

WARNING: The full AC line voltage is present at several points (fuseholder, main circuit board, etc.). Be careful to avoid personal shock when performing the checks described.

HOW TO TROUBLESHOOT YOUR MOST ACCURATE CLOCK

If you know which area your trouble is in, apply the "Visual Checks" to that area.

You may also go directly to the "Troubleshooting Charts" to see if the difficulty you are having is listed in one of the "Problem" columns. If your difficulty is listed there, check the "Possible Causes" listed for that problem and apply the "Visual Checks" listed to the area of difficulty.

REPAIRING THE MOST ACCURATE CLOCK

When you make repairs to the Most Accurate Clock, make sure you eliminate the cause as well as the

effect of the difficulty. If, for example, you should find a damaged resistor, be sure that you find out what caused the resistor to become damaged. If the cause is not eliminated, the replacement resistor may also become damaged when you put the Clock back into operation. Do Not attempt to align or repair the factory-assembled receiver circuit board. Return the unit for service if the receiver board is suspect.

SHIPPING

IMPORTANT: If it becomes necessary to ship the Most Accurate Clock to the Heath Company or a Heath Electronic Center, attach the top and bottom covers to protect the circuit boards during shipment and remove the telescoping antenna.

TROUBLESHOOTING CHART

This Troubleshooting Chart lists specific difficulties that could occur in your Most Accurate Clock. Several possible causes may be listed for each difficulty. Refer to the "X-Ray Views" of the circuit board and the Schematic Diagram to locate and identify the parts listed in this chart.

If a particular part is mentioned (R101 for example) as a possible cause, check that part and other components connected to that part to see that they are in-

stalled and/or wired correctly. Also check for solder bridges and poor connections in the surrounding area. It is also possible, on rare occasions, for a part to be faulty and require replacement.

NOTE: Check each indicated resistor in the problem area and make sure it is not interchanged with a similar color-coded resistor. This applies mainly to the 1% precision resistors, which are especially easy to misread.

PROBLEM	POSSIBLE CAUSE
No display (nothing on the display circuit board is lit).	<ol style="list-style-type: none"> 1. Fuse F201 is open (or fuse F202 if you are operating on 12 VDC). 2. Display switch S101 is in the Off position. 3. S101 is improperly soldered or faulty.
Digits will not light. All appropriate LEDs are lit.	<ol style="list-style-type: none"> 1. Normal condition if the clock has not set itself, or if power was lost temporarily. 2. U101 is defective or improperly installed. 3. Stop switch S502 is shorted.
One digit is lit, other digits are off.	<ol style="list-style-type: none"> 1. Clock oscillator is inoperative. Check transistors Q204 through Q207 and their associated components. 2. Microprocessor IC U203. 3. This may be normal if the Clock has not set itself.

PROBLEM	POSSIBLE CAUSE
Improper display in the Test mode.	<ol style="list-style-type: none"> 1. Stop switch S502 is shorted. 2. Wiring from the main to the test circuit boards is incorrect.
Unusual display in the Normal mode.	<ol style="list-style-type: none"> 1. Microprocessor IC U203 may not have reset properly after a power loss. Disconnect the power for several seconds and then reapply the power.
Data LED is not lit during the Normal mode of operation. It is OK in the 100 Hz test and calibration mode.	<ol style="list-style-type: none"> 1. Insufficient WWV signal. A better antenna is necessary. (This may be normal at certain times of the day or during poor signal conditions).
Data LED is never on (not even during the 100 Hz alignment procedure).	<ol style="list-style-type: none"> 1. Data LED (D108) is installed wrong or is faulty.
Capture LED never turns on (not even in test mode 1).	<ol style="list-style-type: none"> 1. Capture LED is installed wrong or is faulty.
Capture LED never turns on during the 1000 Hz (or 1200 Hz for WWVH) test and calibration procedure.	<ol style="list-style-type: none"> 1. IC U404 and its associated circuitry. 2. IC U403 and its associated circuitry.
PM LED never on during the normal mode (OK in test).	<ol style="list-style-type: none"> 1. Insufficient WWV signal. A better antenna system may be necessary. (This may be normal at certain times of the day or during poor signal conditions).
Hi Spec LED does not light (test mode 1).	<ol style="list-style-type: none"> 1. Hi Spec LED (D105) is installed backward or is faulty. 2. Transistor Q128 is faulty.
Hi Spec LED is rarely lit.	<ol style="list-style-type: none"> 1. Insufficient WWV signal. A better antenna system may be necessary. (This may be normal at certain times of the day or during poor signal conditions.)
Channel LED(s) not lit in test mode 1.	<ol style="list-style-type: none"> 1. LEDs installed wrong or are faulty. 2. Transistors Q124, Q125, or Q126 are faulty.
All channel LEDs are lit in the normal mode.	<ol style="list-style-type: none"> 1. All the channel lockout switches on the bottom of the cabinet are in the lockout position.
No audio. (if under auto mute, audio will be on only if the Hi Spec LED is lit.)	<ol style="list-style-type: none"> 1. Speaker or speaker wiring. 2. Connect the plug from the Volume control switch to P303 on the receiver circuit board so that there are wires going to pins 1 and 2 of the plug.
Audio is noisy.	<ol style="list-style-type: none"> 1. Interference from power line connections (TV, power tools, etc.).

SPECIFICATIONS

Receiver	
Type	AM heterodyne, single conversion with tuned RF amplifier.
Sensitivity	1 μ V or less for 10 dB SINAD*.
Audio Output	250 mW into 8 Ω , for 10% THD.
Clock	
Accuracy	Within 10 ms when the Hi Spec LED is on.
Power Requirements	120 (240) \pm 15 VAC, 50/60 Hz @ 100 mA (50 mA), or 11 to 16 VDC @ 750 mA (150 mA with display turned off).
Size	9" wide \times 6-1/4" deep \times 3-7/8" high (less antenna) (22.9 \times 15.6 \times 9.8 cm).
Operating Temperature Range	32° to 100° F. (0° - 38° C).
Storage Temperature Range	0° to 130° F. (- 18° to 55° C).

* $\frac{\text{signal} + \text{noise}}{\text{noise}}$

The Heath Company reserves the right to discontinue products and to change specifications at any time without incurring any obligation to incorporate new features in products previously sold.

CIRCUIT DESCRIPTION

Refer to the Block Diagram (Illustration Booklet, Page 17) and the Schematic Diagram (fold-in) while you read this Circuit Description.

POWER SUPPLY CIRCUIT – U201 & U202

The 120 VAC, 60 Hz line voltage is stepped down by power transformer T201 and rectified by diode bridge D202 through D205 to form approximately 12 volts DC. Noise and 60 Hz ripple are filtered by coil L201 and capacitors C202, C203, and C204. IC U201 regulates the 12 VDC to 8 VDC. The 8 VDC is further filtered by capacitors C208 and C209 and is the power source for all of the receiver circuits. IC U202 is also a voltage regulator which regulates the 12 VDC to 5 VDC for all the rest of the clock circuits. Capacitors C206 and C207 filter this 5 VDC. Resistor R201 reduces some of the voltage to prevent excessive power dissipation in IC U202.

If the 12 VDC is supplied directly by an external source, diode D201 protects the circuits from damage if the input voltage polarities are accidentally reversed.

CLOCK OSCILLATOR CIRCUIT – Q204 through Q207

The 3.6 MHz crystal, Y201, transistor Q204, and their associated components form a Colpitts oscillator which oscillates at 3.6 MHz. This 3.6 MHz signal is coupled through capacitor C221 to transistor Q205, which amplifies the signal and isolates transistor Q204 from the load on Q205.

This amplified signal is coupled through capacitor C223 to microprocessor IC U203 (and microprocessor IC U404 if the GCA-1000-1, RS-232C option is installed) and sequences the microprocessor through its functions. In addition, this signal is directly coupled to a complementary pair amplifier, transistors Q206 and Q207, which amplify and isolate the 3.6 MHz signal further so that it may be used as a reference frequency.

OSCILLATOR TRIM CIRCUIT – U205 & Q203

The oscillator trim circuit causes an 8-bit binary value, supplied by the microprocessor IC U203, to shift the frequency of the clock oscillator slightly. To accomplish this, microprocessor IC U203 holds a 4-bit binary value on the D0 – D3 input lines of latch IC U205, while it varies a 4-bit binary code on the A – D input lines of IC U204 to output a brief pulse on its Q8 and Q9 lines. This strobe pulse causes the information on D0 – D3 of IC U205 to be “latched” on its output lines, Q0 – Q3. Similarly, information on inputs D4 – D7 of IC U205 are transferred and held on its Q4 – Q7 output lines. Thus, the function of U205 is to hold an 8-bit binary value on its outputs, even though this 8-bit code is only briefly applied to its inputs.

This 8-bit binary output at Q0 – Q7 of U205 is applied to a resistive ladder network at R223. This causes the output voltage at pin 1 of R223 to be a DC voltage proportional to the 8-bit digital value. Transistor Q203 is a buffer for this DC voltage, which is applied through resistor R212 to the cathode of varactor diode D224. The anode of D224 is connected to ground through resistor R213, reverse biasing diode D224. This condition causes the junction of D224 to act as a capacitor, whose capacitance is inversely related to the reverse bias voltage applied across D224. This capacitance affects the clock oscillator frequency and causes it to change slightly.

BINARY TO DECIMAL DECODER — U204

Binary to decimal IC U204 has ten distinct outputs at Q0 – Q9 and four input lines at A – D. When microprocessor IC U203 applies a 4-bit binary value, IC U204 decodes the binary value into a decimal value and causes the associated decimal output line to go high. Binary values greater than 9 are ignored and none of the output lines will go high. An output line is not latched high and, therefore, an output will remain high only while the associated binary value is held on its input lines. The function of IC U204 is to expand the number of output lines of microprocessor IC U203 by 6 (from 4 to 10).

As previously described, output lines Q8 and Q9 of U204 strobe latch IC U205 and cause the brief binary input information on IC U205 to hold the 8-bit binary information on its output lines. Output

lines Q0 – Q6 of U204 turn on the individual display digits via transistors Q116 through Q123. In addition, output Q6 turns on transistor Q201 and allows microprocessor IC U203 to “read” the status of the eight switches at S201 on its input lines 8 through 15. In the same manner, output Q7 turns on transistor Q202 and allows the switch settings of S202 to be read by the microprocessor.

CLOCK MICROPROCESSOR – U203

Clock microprocessor U203 has many important functions. One function, as previously discussed, supplies an 8-bit binary value to the oscillator trim circuit to adjust the clock frequency. It also supplies the appropriate 4-bit binary value to IC U204 to turn on the various display digits and to activate transistors Q201 and Q202 so that the switch settings at S201 and S202 can be read. In addition, the microprocessor is programmed to react to these switch settings in a prescribed manner.

The microprocessor turns the LED indicators on and off via transistors Q124 through Q131 and can turn the audio amplifier on and off via transistors Q314 and Q315. It selects the receiver bands by supplying 3-bits of binary information to IC U301 and can determine which band is strongest by monitoring the output of IC U404C.

The microprocessor monitors the outputs of the 100 Hz and 1000 Hz tones from the tone decoders, and then determines the length of time these tones are present. The tones contain the beginning of the minute, time, date, UTC 1, correction factor, and daylight savings time information being sent by WWV. The WWV information is compared several times by the microprocessor to insure that it is correct. The microprocessor also functions as a clock that uses WWV information to reset itself. It also sends the time and Julian date to optional RS-232C microprocessor IC U401.

The microprocessor checks the S501 test switch to see if the test mode is selected. If it is, it sends signals to check the display digits and LEDs, sets the time and date, and generates tones to align the tone decoders. When S501 is in the normal mode, the microprocessor freezes the displayed time when the Stop switch (S502) is depressed.

DIGITAL DISPLAY CIRCUITRY – (U101, V101 – V107, Q101 – Q131, D101 – D108)

The digital display is multiplexed, which means that only one digit is turned on at any given time. However, each digit is turned on approximately 100 times each second. This gives the appearance that all digits are turned on simultaneously.

The microprocessor sends the appropriate BCD (binary coded decimal) signals to BCD-to-7-segment decoder IC U101. U101 decodes these signals into the 7-segment format of the LED digits and turns the appropriate segment driver pairs (Q101 – Q115) on. At the same time, the microprocessor sends a 4-bit binary code to IC U204 and causes one of its Q0 - Q6 output lines to turn on the desired digit driver transistor (Q116 – Q123). This digit is turned on for approximately 1.25 mS. Then the microprocessor outputs appropriate signals to light the next digit. This procedure is repeated again and again.

The individual LED indicators are driven statically (they are either on or off as directed by their function, not rapidly turned on and off like the digits). The microprocessor decides which LEDs to turn on and supplies a high signal (approximately 5 VDC) to the transistors (Q124-Q131) connected to the LEDs to be lit. Note that the data LED (D108) is not controlled by the microprocessor. It will be discussed in the following section.

TONE DECODER CIRCUITRY – U404A, B, & D, U402, U403

The primary function of these circuits is to detect the 1000 Hz and 100 Hz tones sent on the WWV carrier signals. The receiver detects the audio signals amplitude modulating (AM) the carrier. The audio signal is amplified by audio preamplifier IC U404D. The signal is then coupled to active bandpass filter ICs U404A and U404B. These filters reject some of the unwanted audio signals and amplify the desired 100 Hz and 1000 Hz signals. The 100 Hz tone is passed by active filter IC U404A and coupled to 100 Hz tone decoder IC U402.

The tone decoder IC contains a phase locked loop (PLL) circuit which has a voltage-controlled oscillator (VCO). When the input signal is very close to the same frequency as the VCO, an error signal is detected and corrects the VCO frequency to make it the same as the input signal frequency. When both the input and VCO are the same, the output at pin 8 of IC U402 will go low. This causes the data LED (D108) to turn on and tell the microprocessor, which is monitoring the output of U402, that a 100 Hz signal is being received. The microprocessor times the length that the tone is present to decide if it is a binary "0," "1," a 10-second marker, or an invalid signal. Note that the VCO frequency should be set properly as outlined in the "Initial Tests and Calibration" section of this Manual.

In the same manner, 1000 Hz tone decoder IC U403 detects at or near 1000 Hz when its VCO frequency is adjusted properly. The microprocessor monitors this output and also uses the information to determine when the beginning of the minute occurs (i.e. 00.0 seconds). If the microprocessor decides this is the beginning of the proper 1000 Hz tone, it lights the capture LED.

AUTOMATIC GAIN CONTROL (AGC) LEVEL SENSING CIRCUIT – U404C

This circuit compares eight different voltage levels to the receiver AGC voltage. The microprocessor uses this to determine which receiver channel is receiving the best WWV channel.

The microprocessor sends eight different 3-bit binary signals to diodes D402 through D404. The voltage divider formed by resistors R415 - 419 converts these signals into eight voltage levels. These voltages are applied to input pin 3 of IC U404C. The receiver AGC voltage is applied to pin 2 of U404C. Whenever the AGC voltage is less than the divider voltage at pin 3, the output at pin 4 of U404C goes low. The microprocessor monitors this output voltage and can thereby determine which channel is best. This is true since the microprocessor controls both the voltage of the divider circuit and the receiving channel being used. There are conditions, however, that can make a channel appear strongest (when AGC voltage is lowest), such as noise or interference by other

broadcasts. In those cases, it will be necessary to use the channel lock switch (SW201) so that the Clock will not use those channels. The circuit formed by transistor Q403, diode D406, capacitor C425, and resistors R445 through R449, is used to "weight" the AGC level sensing. This weighting makes a channel receiving the data from WWV, appear stronger than channels that are not receiving this data.

RECEIVER CIRCUITS

The receiver is a heterodyne, amplitude modulated receiver, designed to receive the 5, 10, and 15 MHz WWV broadcast signals. This receiver consists of a tuned RF amplifier, a mixer, a local oscillator, an IF amplifier, a diode detector, an audio amplifier, an audio mute circuit, and band switching circuits.

Band Switching Circuit – U301, Q301 – Q303

Clock microprocessor IC U203 applies a 2-bit binary coded signal to input pins 5 and 9 and a strobe pulse to the clock at input pins 3 and 11 of dual D flip-flop IC U301. This causes the IC to retain this information at its outputs until new data is strobed into it. When the Q1 output (pin 1) of U301 is low, transistor Q301 turns on and causes diodes D302, D307, and D311 to conduct. The receiver is then set to receive the 5 MHz WWV signals. When the Q2 output (pin 13) is low, transistor Q302 turns on causing diodes D303, D306, and D309 to conduct. This selects the tuned circuits and crystal for the reception of the 10 MHz signal. Thus, by diode switching, certain tuned circuits and crystals are selected so the receiver can receive the desired WWV channels. This band selecting is controlled by clock microprocessor IC U203.

To simplify the following description, assume that the 5 MHz band has been selected by the microprocessor.

RF Amplifier – Q306 & Q307

The 5 MHz signal broadcast by WWV is received by the telescoping antenna (or external antenna, if used) and coupled through transformer L303. The secondary inductance of L303, capacitors C318, C319, and C321, and inductor L304, form a bandpass filter tuned to 5 MHz. This signal is coupled through

capacitor C319 and amplified by transistors Q306 and Q307. Inductor L307 and capacitors C333 and C334 are a 5 MHz tuned circuit which allows the RF amplifier to have its maximum gain at this frequency. Transistor Q308 is a buffer amplifier with no gain, but helps match the RF amplifier from the local oscillator circuit. The signal is coupled to mixer transistor Q309 through capacitor C336.

Local Oscillator – Q305, Y301, Y302, Y303

Diode D302 and crystal Y301 connect to the rest of the oscillator circuit formed by transistor Q305, resistors R323, R325, and capacitors C308 and C309. This circuit oscillates at 5.455 MHz and is coupled to the mixer circuit via capacitor C337.

Mixer – Q309

The 5 MHz signal from the RF amplifier and the 5.455 MHz signal from the local oscillator are mixed by transistor Q309 to produce a difference signal of 455 kHz (the IF frequency). The primary of transformer T301 is tuned to 455 kHz and passes the IF signal to the IF amplifier transistor Q311.

IF Amplifier – Q311, Q312, Y304

IF amplifier transistor Q311 amplifies the 455 kHz signal and filters it with the tuned circuit at IF transformer T302. The IF transformer then couples the signal to ceramic filter Y304, which also filters the IF signals, and passes only the 455 kHz signal to IF amplifier transistor Q312. The IF signal is amplified and filtered further by Q312 and transformer T303. The signal then goes through T303 to the detector diode D312.

Detector – D312

Diode D312 and capacitor C345 form a network that detects the amplitude variations in the IF signal. This detected signal is filtered by the low-pass network, resistor R361 and capacitor C346. Thus, the 100 Hz and 1000 Hz tones are now recovered from the WWV signal (as are the other audible frequencies). These audible frequencies are coupled to the audio amplifier circuit through the Volume control, and to the tone decoder circuits.

Automatic Gain Control (AGC) Circuit – Q313

Resistors R351, and R352, and capacitor C359 form an AGC circuit. This circuit filters out the audio signal but produces a DC voltage that is inversely related to the average amount of IF signal coupled to the detector. This is the AGC voltage; it is buffered by AGC amplifier transistor Q313. From here, the AGC voltage adjusts the bias voltage on RF amplifier transistor Q306 and IF amplifier transistor Q311. This helps control the gain of these two amplifiers and maintains a nearly constant audio signal level over extremely wide variations in the received RF signal levels. The AGC voltage is also coupled to the signal level sensing circuit at IC U404C, which helps the microprocessor to determine which WWV channel is the strongest.

Audio Amplifier – U302

The audio signal, which passes through the Volume control, is coupled to the input of audio amplifier IC U302 via capacitor C349. The audio amplifier amplifies this signal and couples it through capacitor C355 to the speaker.

Audio Mute – Q314 & Q315

Transistors Q314 and Q315, capacitor C354, diode D313, and resistors R362 through R366 form a muting circuit. When transistors Q314 and Q315 are turned on causing the voltage at pin 7 of the audio amplifier IC U302 to go high, the audio amplifier is disabled. In this condition, the audio signal does not pass through U302 and nothing is heard from the speaker. If the voltage from the microprocessor is high and is applied at the cathode of diode D313 through Volume control switch S1, the diode will not pass the audio signals. This circuit, in effect, allows the microprocessor to turn the audio on and off.

SEMICONDUCTOR IDENTIFICATION CHART

DIODES

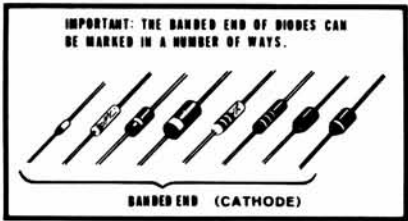
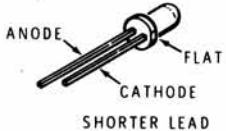
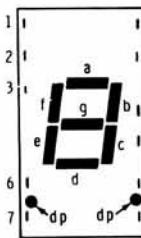
COMPONENT NUMBER	HEATH PART NO.	MAY BE REPLACED WITH	DESCRIPTION
ZD401*	56-16	1N5231B	
D301 - D313	56-24	1N458	
D206 - D209, D211 - D219, D221, D222, D223, D401* - D405	56-56	1N4149	
D224	56-640	MV2110	
D201 - D205	57-65	1N4002	
D101, D102, D103, D106, D107	412-633	Red LED, 1.6 V, 20 mA	
D108	412-641	Yellow LED, 2.2 V, 20 mA	
D104, D105	412-642	Green LED, 2.5 V, 20 mA	
V101 - V104	411-860		<p>TOP VIEW</p>  <p>PIN CONNECTION</p> <ol style="list-style-type: none"> 1. ANODE a 2. ANODE f 3. CATHODE 4. NO PIN 5. NO PIN 6. NO CONNECTION 7. ANODE e 8. ANODE d 9. ANODE dp 10. ANODE c 11. ANODE g 12. NO PIN 13. ANODE b 14. CATHODE

* Part used in GCA-1000-1
Output accessory only

Heathkit®

DIODES

COMPONENT NUMBER	HEATH PART NO.	MAY BE REPLACED WITH	DESCRIPTION
V105 - V107	411-864		<p>FRONT VIEW</p>  <p>2. CATHODE 3. ANODE f 4. ANODE g 5. ANODE e 6. ANODE d 9. CATHODE 10. ANODE dp 11. ANODE c 12. ANODE b 13. ANODE a</p>

TRANSISTORS

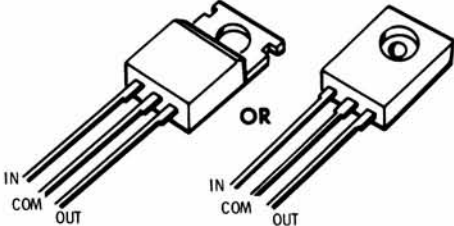
COMPONENT NUMBER	HEATH PART NO.	MAY BE REPLACED WITH	DESCRIPTION
Q101 - Q107, Q207, Q301, Q302, Q303, Q313, Q315	417-874	2N3906	
Q204, Q305	417-293	2N5770	
Q108, Q109, Q111 - Q115, Q124 - Q129, Q131, Q201, Q202, Q203, Q205, Q206, Q304, Q311, Q312, Q314	417-801	MPSA20	
Q116 - Q119 Q121 - Q123	417-881	MPSA13	
Q306, Q307, Q308	417-887	MPSH10	
U202	442-54	UA7805	

INTEGRATED CIRCUITS

COMPONENT NUMBER	HEATH PART NO.	MAY BE REPLACED WITH	DESCRIPTION
U404	442-71	LM3900	
U302	442-612	LM386	
U402, U403	442-688	NE567N	
U201	442-691	78M08	

COMPONENT NUMBER	HEATH PART NO.	MAY BE REPLACED WITH	DESCRIPTION
U204	443-1202	MC14028	
U205	443-736	MC14508	
U101	443-931	MC14543	
U203	444-293-1	Programmed microprocessor available only from Heath Company.	

RECEIVER CIRCUIT BOARD REPLACEMENT PARTS LIST

(#181-4332-1)

CIRCUIT Comp. No.	HEATH Part No.	DESCRIPTION	CIRCUIT Comp. No.	HEATH Part No.	DESCRIPTION
RESISTORS					
NOTE: All resistors are 1/4-watt, 5%.					
R300	Not used		R334	6-103-12	10 kΩ
R301	6-333-12	33 kΩ	R335	6-103-12	10 kΩ
R302	6-333-12	33 kΩ	R336	6-102-12	1000 Ω
R303	6-333-12	33 kΩ	R337	6-102-12	1000 Ω
R304	6-104-12	100 kΩ	R338	6-102-12	1000 Ω
R305	6-333-12	33 kΩ	R339	6-102-12	1000 Ω
R306	6-104-12	100 kΩ	R340	Not used	
R307	6-333-12	33 kΩ	R341	6-101-12	100 Ω
R308	6-104-12	100 kΩ	R342	6-332-12	3300 Ω
R309	6-333-12	33 kΩ	R343	6-183-12	18 kΩ
R310	Not used		R344	6-104-12	100 kΩ
R311	6-684-12	680 kΩ	R345	6-271-12	270 Ω
R312	6-101-12	100 Ω	R346	Not used	
R313	6-102-12	1000 Ω	R347	6-103-12	10 kΩ
R314	6-102-12	1000 Ω	R348	6-473-12	47 kΩ
R315	6-102-12	1000 Ω	R349	6-393-12	39 kΩ
R316	6-104-12	100 kΩ	R350	Not used	
R317	6-104-12	100 kΩ	R351	6-154-12	150 kΩ
R318	6-104-12	100 kΩ	R352	6-103-12	10 kΩ
R319	6-223-12	22 kΩ	R353	6-471-12	470 Ω
R320	Not used		R354	6-101-12	100 Ω
R321	6-183-12	18 kΩ	R355	6-103-12	10 kΩ
R322	6-153-12	15 kΩ	R356	6-101-12	100 Ω
R323	6-103-12	10 kΩ	R357	6-563-12	56 kΩ
R324	6-101-12	100 Ω	R358	6-183-12	18 kΩ
R325	6-102-12	1000 Ω	R359	6-181-12	180 Ω
R326	6-102-12	1000 Ω	R360	Not used	
R327	6-102-12	1000 Ω	R361	6-472-12	4700 Ω
R328	6-102-12	1000 Ω	R362	6-333-12	33 kΩ
R329	6-471-12	470 Ω	R363	6-104-12	100 kΩ
R330	Not used		R364	6-223-12	22 kΩ
R331	6-563-12	56 kΩ	R365	6-104-12	100 kΩ
R332	6-103-12	10 kΩ	R366	6-333-12	33 kΩ
R333	6-561-12	560 Ω	R367	6-103-12	10 kΩ
			R368	6-102-12	1000 Ω
			R369	6-279-12	2.7 Ω
			R370	Not used	
			R371	6-101-12	100 Ω

CIRCUIT Comp. No.	HEATH Part No.	DESCRIPTION	CIRCUIT Comp. No.	HEATH Part No.	DESCRIPTION
CAPACITORS					
C300	Not used		C350	Not used	
C301	25-885	100 μ F electrolytic	C351	21-46	.005 μ F ceramic
C302	21-143	.05 μ F ceramic	C352	21-95	.1 μ F ceramic
C303	21-143	.05 μ F ceramic	C353	25-880	10 μ F electrolytic
C304	21-143	.05 μ F ceramic	C354	25-880	10 μ F electrolytic
C305	21-143	.05 μ F ceramic	C355	25-887	220 μ F electrolytic
C306	Not used		C356	21-95	.1 μ F ceramic
C307	Not used		C357	25-887	220 μ F electrolytic
C308	20-102	100 pF mica	C358	21-143	.05 μ F ceramic
C309	20-114	270 pF mica	C359	25-879	4.7 μ F electrolytic
C310	Not used		C361	Not used	
C311	21-143	.05 μ F ceramic	INDUCTORS – CHOKE – TRANSFORMER		
C312	21-140	.001 μ F ceramic	L301	40-1788	1.8 μ H inductor
C313	21-143	.05 μ F ceramic	L302	40-1787	4.7 μ H inductor
C314	31-97	10-60 pF trimmer	L303	40-1786	13 μ H inductor
C315	21-143	.05 μ F ceramic	L304	45-82	350 μ H choke
C316	31-97	10-60 pF trimmer	L305	40-1792	1.8 μ H inductor
C317	21-143	.05 μ F ceramic	L306	40-1798	4.2 μ H inductor
C318	31-97	10-60 pF trimmer	L307	40-1882	15.5 μ H inductor
C319	20-77	24 pF mica	T301	52-161	IF transformer
C320	Not used		T302	52-161	IF transformer
C321	20-104	130 pF mica	T303	52-161	IF transformer
C322	21-143	.05 μ F ceramic	SEMICONDUCTORS		
C323	21-46	.005 μ F ceramic	Q301	417-874	2N3906 transistor
C324	21-143	.05 μ F ceramic	Q302	417-874	2N3906 transistor
C325	21-143	.05 μ F ceramic	Q303	417-874	2N3906 transistor
C326	20-96	36 pF mica	Q304	417-801	MPSA20 transistor
C327	31-57	2.7-20 pF trimmer	Q305	417-293	2N5770 transistor
C328	21-143	.05 μ F ceramic	Q306	417-887	MPSH10 transistor
C329	20-96	36 pF mica	Q307	417-887	MPSH10 transistor
C330	Not used		Q308	417-887	MPSH10 transistor
C331	31-57	2.7-20 pF trimmer	Q309	417-290	MRF502 transistor
C332	21-143	.05 μ F ceramic	Q310	Not used	
C333	20-96	36 pF mica	Q311	417-801	MPSA20 transistor
C334	31-57	2.7-20 pF trimmer	Q312	417-801	MPSA20 transistor
C335	21-143	.05 μ F ceramic	Q313	417-874	2N3906 transistor
C336	21-3	10 pF ceramic	Q314	417-801	MPSA20 transistor
C337	21-3	10 pF ceramic	Q315	417-874	2N3906 transistor
C338	21-46	.005 μ F ceramic	J301	443-607	MC14013 integrated circuit
C339	21-143	.05 μ F ceramic	U302	442-612	LM386N-4 integrated circuit
C340	Not used		CRYSTALS – FILTER		
C341	21-143	.05 μ F ceramic	Y301	404-685	5.4550 MHz crystal
C342	21-46	.005 μ F ceramic	Y302	404-686	10.4550 MHz crystal
C343	21-143	.05 μ F ceramic	Y303	404-687	15.4550 MHz crystal
C344	21-143	.05 μ F ceramic	Y304	404-630	Ceramic filter
C345	27-128	.022 μ F Mylar			
C346	27-128	.022 μ F Mylar			
C347	21-143	.05 μ F ceramic			
C348	25-879	4.7 μ F electrolytic			
C349	21-95	.1 μ F ceramic			

CUSTOMER SERVICE

REPLACEMENT PARTS

Please provide complete information when you request replacements from either the factory or Heath/Zenith Computers and Electronics centers. Be certain to include the **HEATH** part number exactly as it appears in the parts list.

ORDERING FROM THE FACTORY

Print all of the information requested on the parts order form furnished with this product and mail it to Heath. For telephone orders (parts only) dial 616 982-3571. If you are unable to locate an order form, write us a letter or card including:

- Heath part number.
- Model number.
- Date of purchase.
- Location purchased or invoice number.
- Nature of the defect.
- Your payment or authorization for COD shipment of parts not covered by warranty.

Mail letters to: Heath Company
Benton Harbor
MI 49022
Attn: Parts Replacement

Retain original parts until you receive replacements. Parts that should be returned to the factory will be listed on your packing slip.

OBTAINING REPLACEMENTS FROM HEATH/ZENITH COMPUTER AND ELECTRONICS CENTERS

For your convenience, "over the counter" replacement parts are available from the Heath/Zenith Computer and Electronics centers listed in your catalog. Be sure to bring in the original part and purchase invoice when you request a warranty replacement from a Heath/Zenith Computer and Electronics center.

TECHNICAL CONSULTATION

Need help with your kit? — Self-Service? — Construction? — Operation? — Call or write for assistance. You'll find our Technical Consultants eager to help with just about any technical problem except "customizing" for unique applications.

The effectiveness of our consultation service depends on the information you furnish. Be sure to tell us:

- The Model number and Series number from the blue and white label.
- The date of purchase.
- An exact description of the difficulty.
- Everything you have done in attempting to correct the problem.

Also include switch positions, connections to other units, operating procedures, voltage readings, and any other information you think might be helpful.

Please do not send parts for testing, unless this is specifically requested by our Consultants.

Hints: Telephone traffic is lightest at midweek — please be sure your Manual and notes are on hand when you call.

Heath/Zenith Computer and Electronics center facilities are also available for telephone or "walk-in" personal assistance.

REPAIR SERVICE

Service facilities are available, if they are needed, to repair your completed kit. (Kits that have been modified, soldered with paste flux or acid core solder, cannot be accepted for repair.)

If it is convenient, personally deliver your kit to a Heath/Zenith Computers and Electronics center. For warranty parts replacement, supply a copy of the invoice or sales slip.

If you prefer to ship your kit to the factory, attach a letter containing the following information directly to the unit:

- Your name and address.
- Date of purchase and invoice number.
- Copies of all correspondence relevant to the service of the kit.
- A brief description of the difficulty.
- Authorization to return your kit COD for the service and shipping charges. (This will reduce the possibility of delay.)

Check the equipment to see that all screws and parts are secured. (Do not include any wooden cabinets or color television picture tubes, as these are easily damaged in shipment. Do not include the kit Manual.) Place the equipment in a strong carton with at least **THREE INCHES** of *resilient* packing material (shredded paper, excelsior, etc.) on all sides. Use additional packing material where there are protrusions (control sticks, large knobs, etc.). If the unit weighs over 15 lbs., place this carton in another one with 3/4" of packing material between the two.

Seal the carton with reinforced gummed tape, tie it with a strong cord, and mark it "Fragile" on at least two sides. Remember, the carrier will not accept liability for shipping damage if the unit is insufficiently packed. Ship by prepaid express, United Parcel Service, or insured Parcel Post to:

Heath Company
Service Department
Benton Harbor, Michigan 49022

Heath Company
Benton Harbor, Michigan

The bottom half of the page features a decorative design consisting of three horizontal stripes. The top stripe is a dark blue, the middle stripe is white, and the bottom stripe is a lighter blue. These stripes are separated by thin white lines.