

Assembly
 and
 Operation
 of the



SSB LINEAR AMPLIFIER

MODEL HA-14

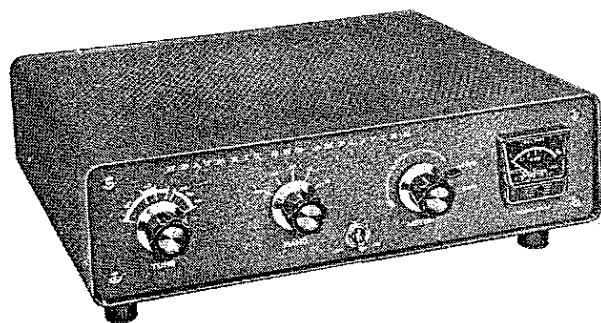

TABLE OF CONTENTS

Introduction.	2
Construction Notes.	2
Parts List.	3
Proper Soldering Techniques.	5
Step-By-Step Procedure.	7
Step-By-Step Assembly -	
Chassis Frame Parts Mounting.	8
Subchassis Wiring.	14
DC Power Socket Wiring.	26
AC Power Socket Wiring.	28
Resistance Check	29
Initial Test.	30
Final Assembly.	30
Installation.	32
Operation.	35
In Case Of Difficulty.	36
Troubleshooting Chart.	37
Service Information -	
Service.	38
Replacements.	39
Shipping Instructions.	39
Warranty.	40
Specifications.	41
Circuit Description.	42
Schematic. . . . (fold-out from page).	43

HEATH COMPANY,
 BENTON HARBOR,
 MICHIGAN

INTRODUCTION

In keeping with the current trend toward higher power SSB (single-sideband) service, the Heathkit Model HA-14 SSB Linear Amplifier is designed to provide high output power for Mobile and fixed station use. Nearly all of the modern SSB Exciters now available can be used as a driver for this Linear Amplifier.

This SSB Linear Amplifier is small and compact for easy mounting in most automobiles. The companion Heathkit Model HP-14 DC Power Supply used with the Linear Amplifier makes

an excellent combination for mobile use. If desired, the Linear Amplifier can be used with the Heathkit Model HP-24 AC Power Supply to make an ideal desk-top 1000 watt PEP amplifier.

The wrap-around construction provides a rugged chassis for good stability, and permits increased cooling of the final tubes. The all-steel cabinet is perforated on all sides for good air circulation to prolong tube and component life.

CONSTRUCTION NOTES

This manual is supplied to assist you in every way to complete your kit with the least possible chance for error. The arrangement shown is the result of extensive experimentation and trial. If followed carefully, the result will be highly stable and dependable performance. We suggest that you retain the manual in your files for future reference, both in the use of the equipment and for its maintenance.

UNPACK THE KIT CAREFULLY AND CHECK EACH PART AGAINST THE PARTS LIST. In so doing, you will become acquainted with the parts. Refer to the information on the inside covers of the manual to help you identify the components. If some shortage or parts damage is found in checking the Parts List, please read the Replacements section and supply the information called for therein.

Resistors generally have a tolerance rating of 10% unless otherwise stated in the Parts List. Tolerances on capacitors are generally even greater. Limits of +100% and -20% are common for electrolytic capacitors.

We suggest that you do the following before work is started:

1. Lay out all parts so that they are readily available.
2. Provide yourself with good quality tools. Basic tool requirements consist of a screwdriver with a 1/4" blade; a small screwdriver with a 1/8" blade; long-nose pliers; wire cutters, preferably separate diagonal cutters; a penknife or a tool for stripping insulation from wires; and a soldering iron (or gun). A set of nut drivers, while not necessary, will aid extensively in construction of the kit.



Most kit builders find it helpful to separate the various parts into convenient categories. Muffin tins or molded egg cartons make convenient trays for small parts. Resistors and capacitors may be placed with their lead ends inserted in the edge of a piece of corrugated cardboard until they are needed. Values can be written on the cardboard next to each component. The illustration shows one method that may be used.

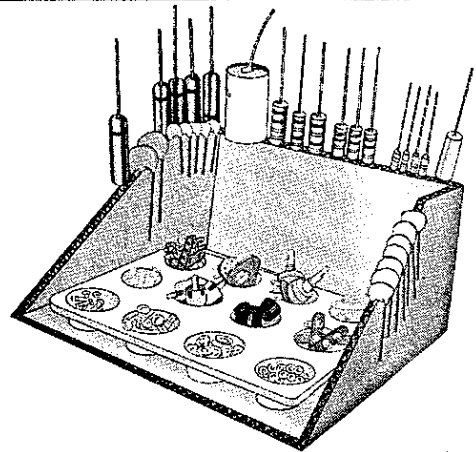

PARTS LIST

The numbers in parentheses in the Parts List are keyed to the numbers on the Parts Pictorial (fold-out from Page 5) to aid in parts identification.

<u>PART No.</u>	<u>PARTS Per Kit</u>	<u>DESCRIPTION</u>	<u>PART No.</u>	<u>PARTS Per Kit</u>	<u>DESCRIPTION</u>
RESISTORS					
1/2 Watt					
(1)1-4	2	330 Ω (orange-orange-brown)	(7)25-39	1	1000 μmf tubular
1-16	2	4700 Ω (yellow-violet-red)	(8)26-96	1	2 μfd electrolytic
1 Watt					
(2)1A-14	3	33 Ω (orange-orange-black)	(9)61-3	1	150 μmf variable
1A-9	1	10 K Ω (brown-black-orange)	(10)63-374	1	
1A-3	1	3300 Ω (orange-orange-red)	63-381	1	
CAPACITORS					
(3)20-40	1	470 μmf molded	69-5	1	
20-123	1	500 μmf molded, 2 KV	CONTROL-SWITCHES-RELAY		
20-42	1	510 μmf molded	(9)61-3	1	DPST toggle switch
(4)20-124	2	115 μmf resin	(10)63-374	1	5-position, 3-wafer rotary switch
20-108	3	200 μmf resin	63-381	1	Switch-control, 20 K Ω control
20-111	1	230 μmf resin	69-5	1	110 V AC DPDT relay
20-121	1	290 μmf resin	COILS-CHOKES-TRANSFORMERS		
20-112	1	310 μmf resin	(11)40-591	1	80 meter input coil
20-131	1	360 μmf resin	40-592	1	40 meter input coil
(5)21-78	1	5 μmf disc	40-593	1	20 meter input coil
21-60	1	18 μmf disc	40-594	1	15 meter input coil
21-14	2	.001 μfd disc	40-595	1	10 meter input coil
21-90	2	.001 μfd 3 KV disc	(12)40-597	1	80, 40, and 20 meter final tank coil
21-31	9	.02 μfd disc	(13)40-645	1	10 and 15 meter final tank coil
(6)21-109	1	100 μmf tubular	(14)45-18	1	28 μh RF choke
21-112	1	350 μmf tubular	(15)45-36	1	7 μh RF choke
			(16)45-53	2	Parasitic plate choke
			(17)45-60	1	10 μh RF choke
			(18)45-61	1	50 μh RF choke



PART No.	PARTS Per Kit	DESCRIPTION	PART No.	PARTS Per Kit	DESCRIPTION
DIODES-TUBES			Insulator-Terminal Strips-Sockets (cont'd.)		
(19)56-24	1	IN458 silicon diode (yellow-green-gray)	432-55	1	Male high voltage connector
(20)56-26	2	IN191 crystal diode (brown-white-brown)	(55)434-9	2	4-pin tube socket
411-198	2	572-B/T-160-L tube	(56)434-42	1	Phono socket
412-17	1	Pilot lamp	434-88	1	Pilot lamp socket
407-108	1	Meter	(57)436-5	1	Coaxial socket
HARDWARE			WIRE-CABLE-SLEEVING		
(21)250-174	2	8-32 x 1/4" screw	340-1	1	Bare wire
(22)250-13	2	6-32 x 1" screw	348-1	1	Enameled wire
(23)250-26	4	6-32 x 5/8" screw	344-21	1	Red stranded hookup wire
(24)250-89	13	6-32 x 3/8" screw	344-29	1	Blue stranded hookup wire
(25)250-218	4	6-32 x 3/8" phillips head screw	344-50	1	Black hookup wire
(26)250-56	24	6-32 x 1/4" screw	344-54	1	Yellow hookup wire
(27)250-138	5	6-32 x 3/16" screw	344-55	1	Green hookup wire
(28)250-4	4	4-40 x 3/8" screw	344-56	1	Blue hookup wire
(29)250-43	3	8-32 x 1/4" setscrew	343-2	1	RG-58 coaxial cable (large)
(30)250-8	4	#6 sheet metal screw	343-7	1	RG-174 coaxial cable (small)
(31)250-143	1	6-32 x 1/2" stud	346-1	1	Sleeving
(32)252-7	3	Control nut	346-10	1	3/8" fiberglass sleeving
(33)252-4	2	8-32 nut	SHEET METAL PARTS		
(34)252-3	38	6-32 nut	90-296	1	Cabinet
(35)252-15	4	4-40 nut	(58)200-M432	1	Subchassis
(36)253-60	8	#6 flat washer	201-M33P141	1	Chassis frame
(37)253-3	1	#10 flat fiber washer	203-M408P140	1	Front panel
(38)254-4	2	Control lockwasher	(59)204-M647	1	Support bracket
(39)254-2	2	#8 lockwasher	(60)206-M275	1	Input shield
(40)254-1	42	#6 lockwasher	MISCELLANEOUS		
(41)254-9	6	#4 lockwasher	435-1	2	Socket mounting ring
(42)259-10	1	Control solder lug	(61)207-42	2	Tube clamp
(43)259-1	16	#6 solder lug	(62)260-34	2	Anode clip
(44)255-21	1	5/16" x 7/8" spacer	260-32	2	Lock clip
(45)255-23	2	5/16" x 15/32" spacer	261-9	4	Rubber foot
INSULATOR-TERMINAL STRIPS-SOCKETS			261-21	2	Rubber foot
(46)71-4	1	Ceramic insulator	(63)438-4	2	Phono plug
(47)431-45	1	6-lug terminal strip	(64)438-9	1	Coaxial plug
(48)431-40	2	4-lug terminal strip	(65)438-12	1	Coaxial plug insert
(49)431-14	1	2-lug terminal strip	(66)455-10	1	3/8" bushing
(50)431-50	1	1-lug terminal strip	(67)455-11	1	Split bushing
(51)431-51	1	2-lug vertical terminal strip	(68)453-135	1	Extension shaft
(52)432-45	1	Male power plug	(69)456-16	1	Shaft coupling
(53)432-46	2	Female power socket	462-191	3	Knob
(54)432-52	1	High voltage connector	(70)462-195	1	Lever knob
			490-5	1	Nut starter
			490-23	1	Allen wrench
			331-6		Solder
			595-732	1	Manual

PROPER SOLDERING TECHNIQUES

Only a small percentage of customers find it necessary to return equipment for factory service. By far the largest portion of malfunctions in this equipment are due to poor or improper soldering.

If terminals are bright and clean and free of wax, frayed insulation and other foreign substances, no difficulty will be experienced in soldering. Correctly soldered connections are essential if the performance engineered into a kit is to be fully realized. If you are a beginner with no experience in soldering, a half hour's practice with some odd lengths of wire may be a worthwhile investment.

For most wiring, a 25 to 100 watt iron or its equivalent in a soldering gun is very satisfactory. A lower wattage iron than this may not heat the connection enough to flow the solder smoothly. Keep the iron tip clean by wiping it from time to time with a cloth.

CHASSIS WIRING AND SOLDERING

1. Unless otherwise indicated, all wire used is the type with colored insulation (hookup wire). In preparing a length of hookup wire, 1/4" of insulation should be removed from each end unless directed otherwise in the assembly step.
2. To avoid breaking internal connections when stripping insulation from the leads of transformers or similar components, care should be taken not to pull directly on the lead. Instead, hold the lead with pliers while it is being stripped.
3. Leads on resistors, capacitors, and similar components are generally much longer than need be to make the required connections. In these cases, the leads should be cut to proper length before the part is installed. In general, the leads should be just long enough to reach their terminating points.

4. Wherever there is a possibility of bare leads shorting to other parts or to the chassis, the leads should be covered with insulating sleeving. Where the use of sleeving is specifically intended, the phrase "use sleeving" is included in the associated assembly step. In any case where there is the possibility of an unintentional short circuit, sleeving should be used. Extra sleeving is provided for this purpose.

5. Crimp or bend the lead (or leads) around the terminal to form a good joint without relying on solder for physical strength. If the lead is too large to allow bending or if the step states that it is not to be crimped, position it so that a good solder connection can still be made.

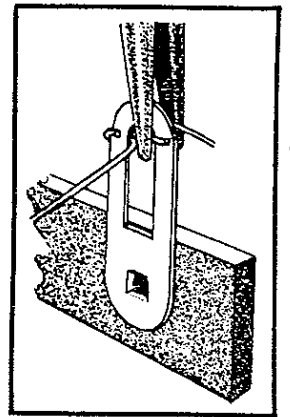

6. Position the work, if possible, so that gravity will help to keep the solder where you want it.

7. Place a flat side of the soldering iron tip against the joint to be soldered until it is heated sufficiently to melt the solder.

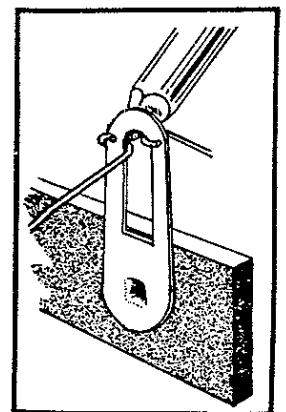

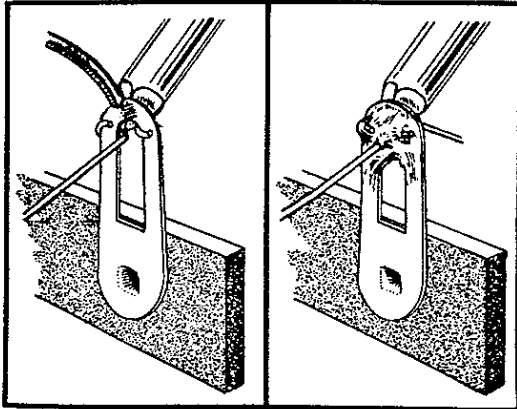

8. Then place the solder against the connection and it will immediately flow over the joint; use only enough solder to thoroughly wet the junction. It is usually not necessary to fill the entire hole in the terminal with solder.
9. Remove the solder and then the iron from the completed joint. Use care not to move the leads until the solder is solidified.

A poor or cold solder joint will usually look crystalline and have a grainy texture, or the solder will stand up in a blob and will not have adhered to the joint. Such joints should be re-heated until the solder flows smoothly. In some cases, it may be necessary to add a little more solder to achieve a smooth, bright appearance.

ROSIN CORE SOLDER HAS BEEN SUPPLIED WITH THIS KIT. THIS TYPE OF SOLDER MUST BE USED FOR ALL SOLDERING IN THIS KIT. ALL GUARANTEES ARE VOIDED AND WE WILL NOT REPAIR OR SERVICE EQUIPMENT IN WHICH ACID CORE SOLDER OR PASTE FLUXES HAVE BEEN USED. IF ADDITIONAL SOLDER IS NEEDED, BE SURE TO PURCHASE ROSIN CORE (60:40 or 50:50 TIN-LEAD CONTENT) RADIO TYPE SOLDER.

STEP-BY-STEP PROCEDURE

The following instructions are presented in a logical step-by-step sequence to enable you to complete your kit with the least possible confusion. Be sure to read each step all the way through before beginning the specified operation. Also read several steps ahead of the actual step being performed. This will familiarize you with the relationship of the subsequent operations. When the step is completed, check it off in the space provided. This is particularly important as it may prevent errors or omissions, especially if your work is interrupted. Some kit builders have also found it helpful to mark each wire and part in colored pencil on the Pictorial as it is added.

ILLUSTRATIONS

The fold-out diagrams in this manual may be removed and attached to the wall above your working area; but because they are an integral part of the instructions, they should be returned to the manual after the kit is completed.

In general, the illustrations in this manual correspond to the actual configuration of the kit; however, in some instances the illustrations may be slightly distorted to facilitate clearly showing all of the parts.

SOLDERING

The abbreviation "NS" indicates that a connection should not be soldered yet as other wires will be added. When the last wire is installed, the terminal should be soldered and the abbreviation "S" is used to indicate this. Note that a number will appear after each solder instruction. This number indicates the number of leads that are supposed to be connected to the terminal in point before it is soldered. For example, if the instruction reads, "Connect a wire to lug 1 (S-2)," it will be understood that there will be two wires connected to the terminal at the time it is soldered. (In cases where a wire passes through a terminal or lug and then connects to another point, it will count as two wires, one entering and one leaving the terminal.)

STEP-BY-STEP ASSEMBLY

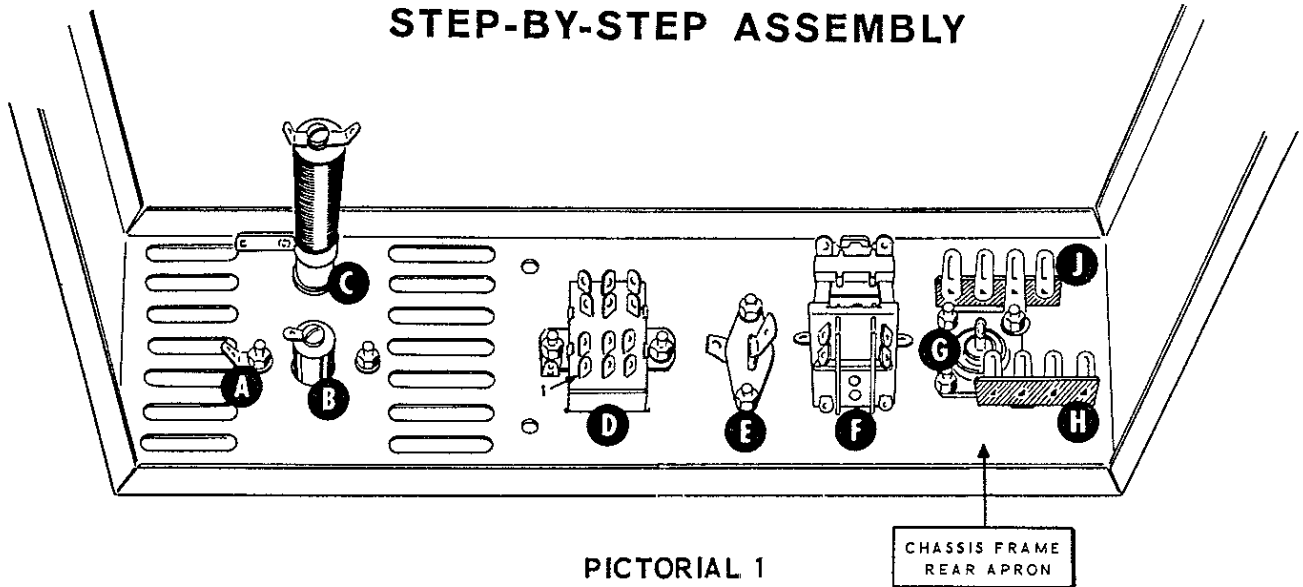

CHASSIS FRAME PARTS MOUNTING

Refer to Pictorial 1 for the following steps.

- () Position the chassis frame as shown in Pictorial 1.
- () Referring to Detail 1A, mount the coaxial socket at G with 4-lug terminal strips at H and J. Use 4-40 x 3/8" screws, #4 lockwashers, and 4-40 nuts. Position the terminal strips as shown.

- () Refer to Detail 1B and mount the male power plug and two lock clips at D with a #6 solder lug on one mounting screw. Use 6-32 x 3/8" screws, #6 lockwashers, a #6 solder lug, and 6-32 nuts. Position lug 1 of the power plug and the #6 solder lug as shown in Pictorial 1.

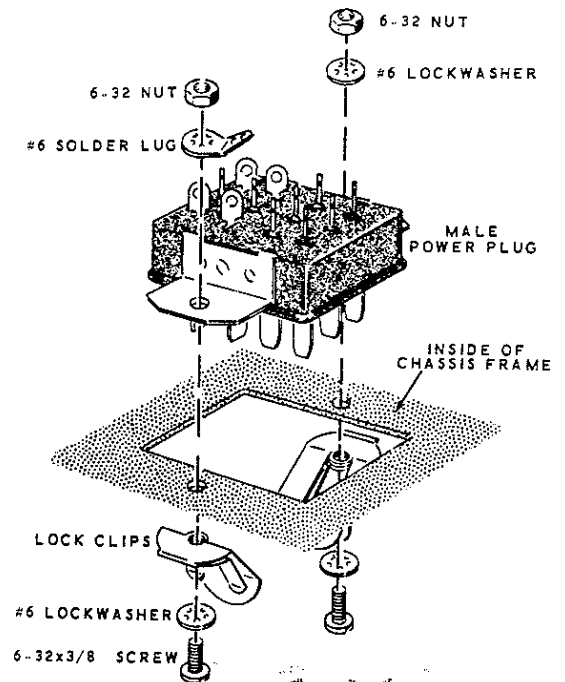
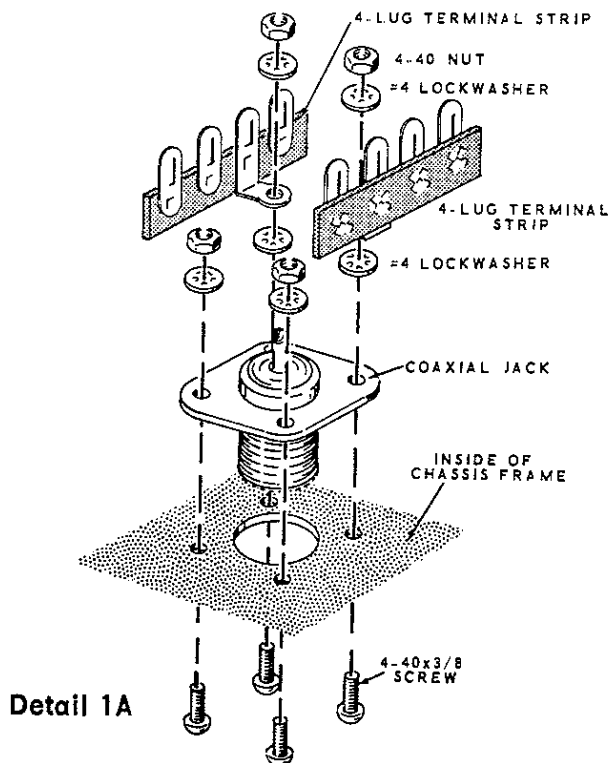

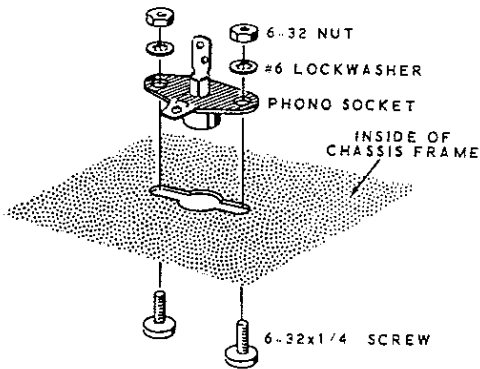

Detail 1C

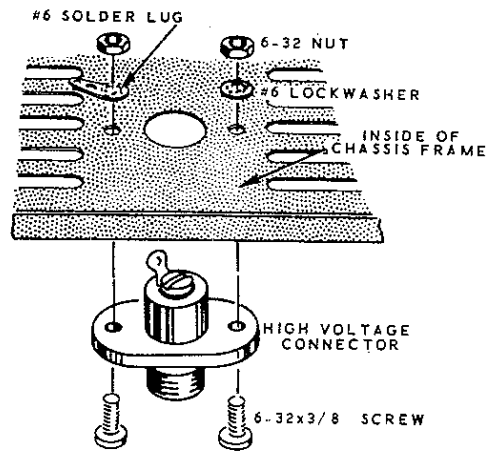

Detail 1E

- () Refer to Detail 1C and mount the phono socket at E with 6-32 x 1/4" screws, #6 lockwashers, and 6-32 nuts. Position the ground lug of the socket as shown.
- () Clip the wire extending from lugs 2, 9, and 10 of relay F as shown in Detail 1D. Do not clip the wire from lug 1; it will be connected later.
- () Referring to Detail 1D, mount the relay at F with a 6-32 x 3/8" screw and a #6 lockwasher. Position the relay so that the locating tab on the bottom of the relay fits into the locating slot in the chassis frame.

- () Mount the high voltage connector socket at B and a #6 solder lug at A. Use 6-32 x 3/8" screws, a #6 lockwasher, a #6 solder lug, and a 6-32 nut as shown in Detail 1E.
- () Refer to Detail 1F and mount the 50 μ h RF choke (#45-61) at C. Use a 6-32 x 3/8" screw and a flat fiber washer. Do not overtighten the screw or the ceramic form will crack. Position the choke lugs as shown in Pictorial 1.

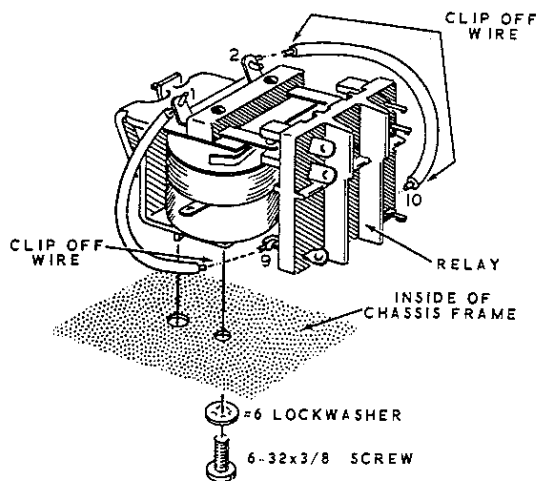

Detail 1D

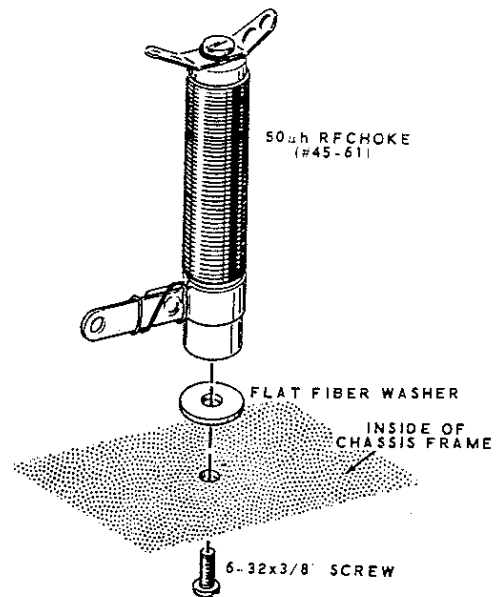

Detail 1F

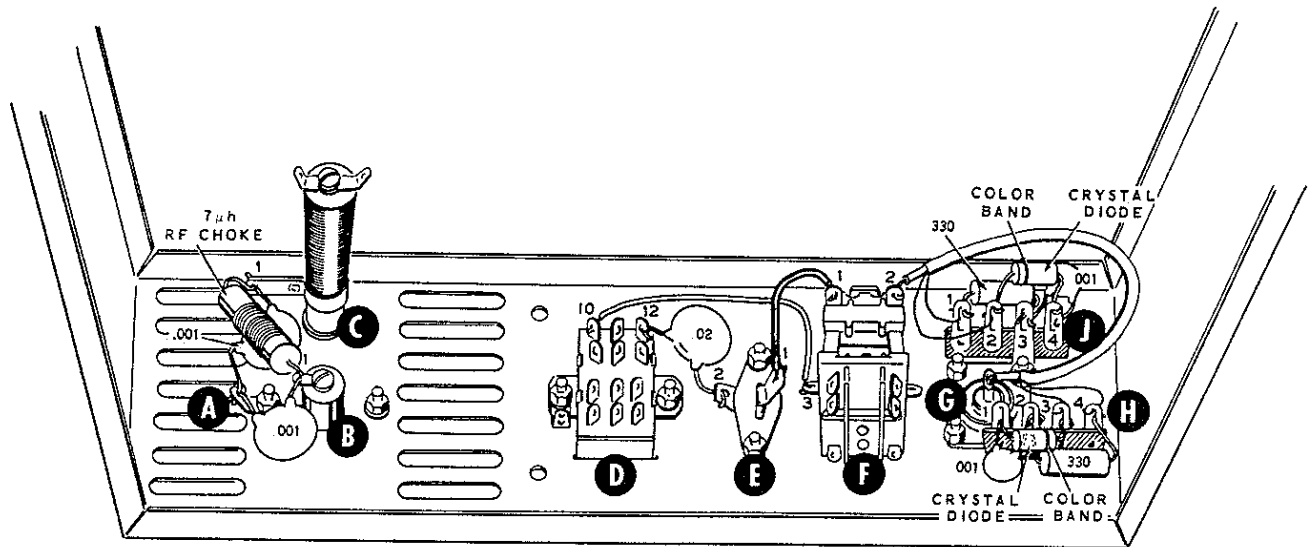

PICTORIAL 2

Refer to Pictorial 2 for the following steps.

- (f) Connect a .001 μ fd 3 KV disc capacitor from lug 1 of high voltage connector B (NS) to solder lug A (NS).
- (A) Connect a .001 μ fd 3 KV disc capacitor from lug 1 of RF choke C (NS) to solder lug A (S-2).
- (A) Connect a 7 μ h RF choke (#45-36) from lug 1 of high voltage connector B (S-2) to lug 1 of RF choke C (S-2).
- * (N) Connect a 3-1/2" yellow wire from lug 10 of power plug D (NS) to lug 3 of relay F (S-1).
- * (N) Connect a .02 μ fd disc capacitor from lug 12 of power plug D (NS) to lug 2 of phono socket E (NS).
- * (N) Remove 1/4" of insulation from the free end of the wire extending from lug 1 of relay F. Connect the wire to lug 1 of phono socket E (S-1).
- (N) Connect a .001 μ fd disc capacitor between lugs 1 (NS) and 2 (NS) of terminal strip H.
- (N) Connect a 330 Ω (orange-orange-brown) resistor between lugs 2 (NS) and 4 (NS) of terminal strip H.
- (J) Connect the lead at the color band end of a crystal diode (brown-white-brown) to lug 3 (NS) and the other lead to lug 1 (NS) of terminal strip H.
- (A) Connect a .001 μ fd disc capacitor between lugs 3 (NS) and 4 (NS) of terminal strip J.
- (Y) Connect a 330 Ω (orange-orange-brown) resistor between lugs 1 (NS) and 3 (NS) of terminal strip J.
- (J) Connect the lead from the color band end of a crystal diode (brown-white-brown) to lug 2 (NS) and the other lead to lug 4 (NS) of terminal strip J.

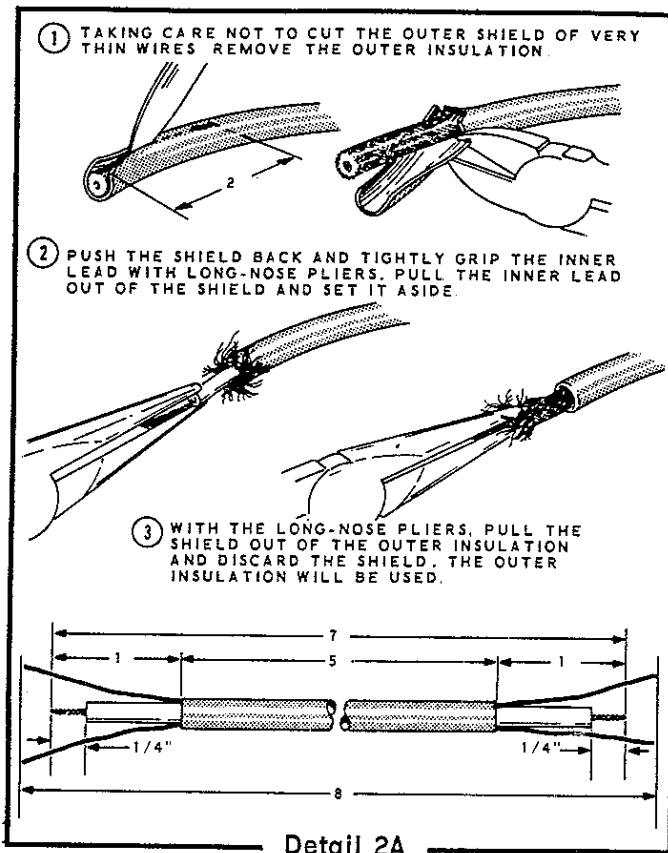

Refer to Detail 2A for the following steps.

- () Cut a 7" length of the RG-58 coaxial cable (large) and remove the inner lead and shield braid. The shield braid may be discarded.
- () Remove 1/4" of insulation from each end of the inner lead and melt a small amount of solder on the exposed wire ends to hold the strands together.
- () Cut two 8" lengths of enameled copper wire. Scrape the enamel from each end of the two wires. Use a knife or some other sharp-edged tool. Melt a small amount of solder on the scraped wire ends to help with soldering later.

- () Place one of the enameled wires through the outer insulation of the length of coaxial cable. Mark both ends of this wire so it can be identified later. A length of tape works very well for this.
- () Place the remaining enameled wire through the insulation.
- () Place the inner lead of the coaxial cable through the insulation with the enameled wires.
- () Position the cable on the rear apron as shown in Pictorial 2. At one end of this cable, connect the inner lead and enameled copper wires as follows:
 - (^) The inner lead to lug 1 of coaxial socket G (S-1).
 - (^) The marked enameled wire to lug 4 of terminal strip H (S-2).
 - (^) The unmarked enameled wire to lug 3 of terminal strip H (S-2).

At the other end of this cable, connect the inner lead and enameled copper wires as follows:

- (^) The inner lead to lug 2 of relay F (S-1).
- (^) The marked enameled wire to lug 2 of terminal strip J (S-2).
- (^) The remaining enameled wire to lug 1 of terminal strip J (S-2).

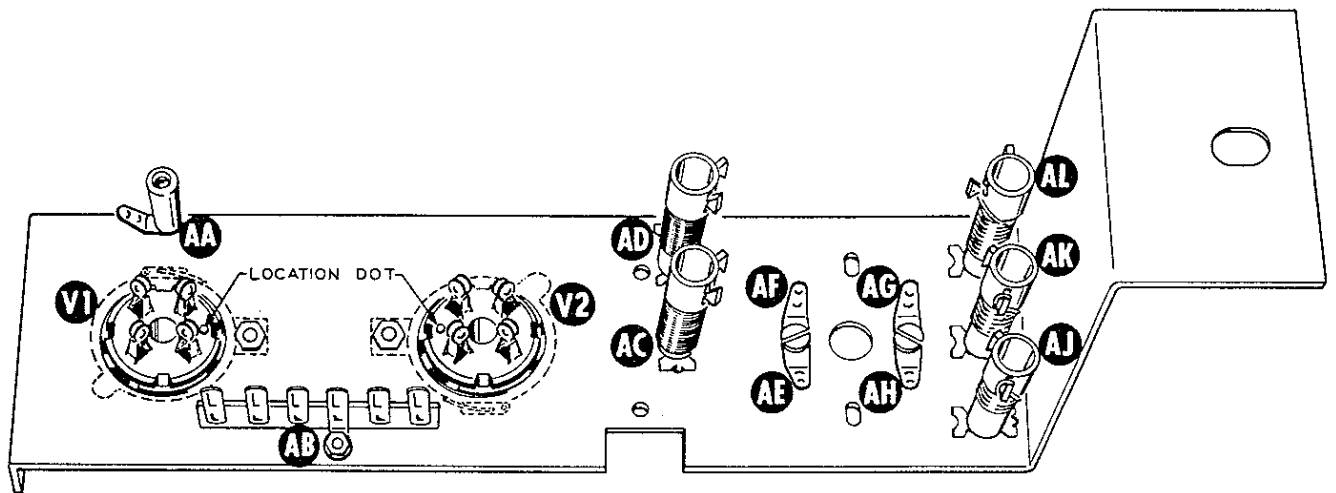

PICTORIAL 3

Refer to Pictorial 3 for the following steps.

() Refer to Detail 3A and mount the 4-pin tube sockets at V1 and V2 with socket mounting rings. Position the location dot of the tube sockets as shown in Pictorial 3.

() Referring to Detail 3B, mount a 6-lug terminal strip at AB. Use a 6-32 x 1/4" screw, #6 lockwashers, and a 6-32 nut.

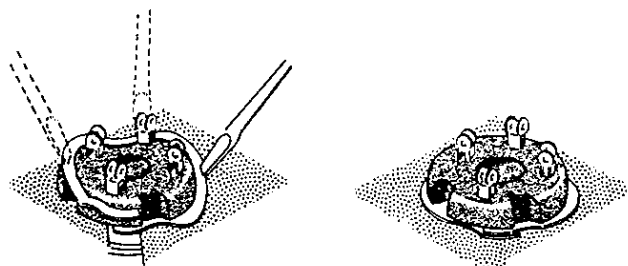

HOLD THE SOCKET IN THE CHASSIS AND PLACE ONE END OF THE RING INTO THE GROOVE OF THE SOCKET. USING A SCREWDRIVER PRESS THE RING INTO THE GROOVE AROUND THE SOCKET

Detail 3A

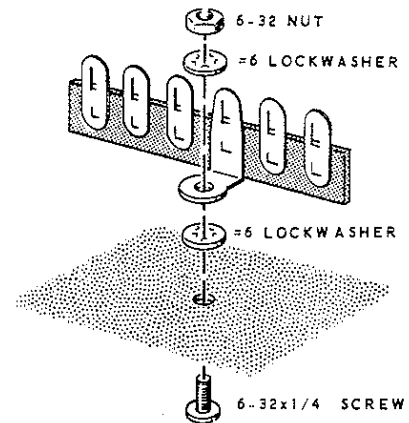

Detail 3B



Detail 3C

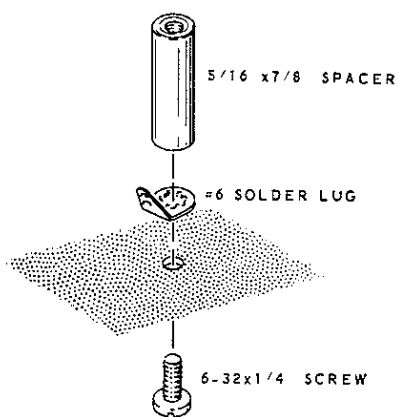

- () Mount the 5/16" x 7/8" spacer at AA with a 6-32 x 1/4" screw and a #6 solder lug, as shown in Detail 3C. Position the solder lug as shown in Pictorial 3.
- () Referring to Detail 3D, mount a tube clamp over sockets V1 and V2. Use 8-32 x 1/4" screws, #8 lockwashers, and 8-32 nuts. Position the tube clamps as shown by the dotted lines on Pictorial 3.

Detail 3D

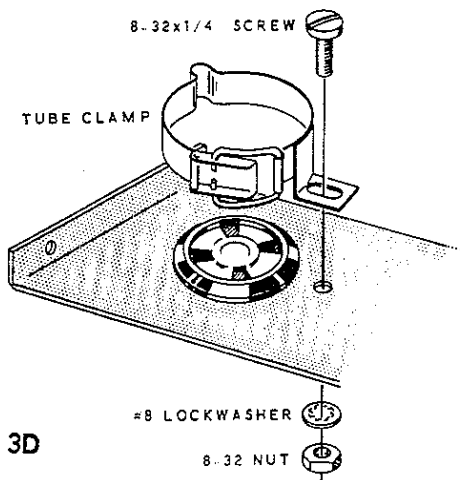

- () Mount #6 solder lugs at AE and AF with a 6-32 x 1/4" screw and 6-32 nut. Position the solder lugs as shown.
- () Mount #6 solder lugs at AG and AH with a 6-32 x 1/4" screw and 6-32 nut. Position the solder lugs as shown.

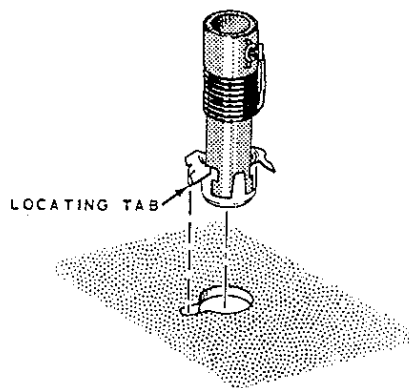

Detail 3E

- () Refer to Detail 3E and mount the 80-meter input coil (#40-591) at AC.

- () Similarly, mount the following input coils.

<u>MOUNT COIL</u>	<u>AT</u>
40 meter (#40-592)	AD
20 meter (#40-593)	AL
15 meter (#40-594)	AK
10 meter (#40-595)	AJ

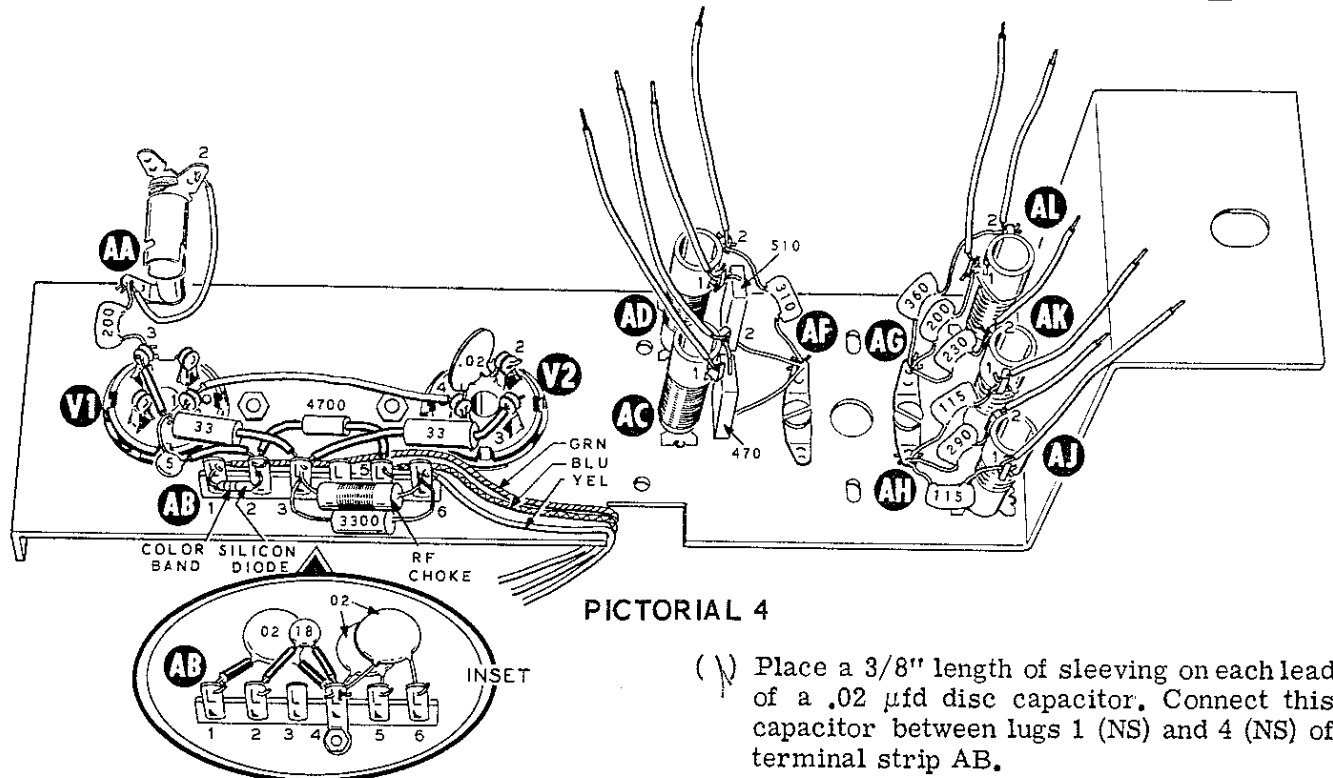

SUBCHASSIS WIRING

Refer to Pictorial 4 for the following steps.

NOTE: Only one end of the following three wires will be connected now. The other end will be connected later.

- () Connect one end of a 13-1/2" green wire to lug 1 of terminal strip AB (NS). Position the other end of this wire as shown.
- () Connect one end of an 11-1/2" blue wire to lug 5 of terminal strip AB (NS). Position the other end of this wire as shown.
- () Connect one end of an 11-1/2" yellow wire to lug 6 of terminal strip AB (NS). Position the other end of this wire as shown.

Refer to the inset drawing on Pictorial 4 for the next four steps.

- () Connect a .02 μ fd disc capacitor between lugs 4 (NS) and 5 (NS) of terminal strip AB.
- () Connect a .02 μ fd disc capacitor between lugs 4 (NS) and 6 (NS) of terminal strip AB.

- () Place a 3/8" length of sleeving on each lead of a .02 μ fd disc capacitor. Connect this capacitor between lugs 1 (NS) and 4 (NS) of terminal strip AB.
- () Place a 1/2" length of sleeving on each lead of an 18 μ fd disc capacitor. Connect this capacitor between lugs 2 (NS) and 4 (S-4) of terminal strip AB.
- () Connect the lead from the color band end of a silicon diode 1N458 (yellow-green-gray) to lug 1 (S-3) and the other lead of this diode to lug 2 (NS) of terminal strip AB.
- () Place a 5/8" length of sleeving on each lead of a 4700 Ω (yellow-violet-red) resistor. Connect this resistor between lugs 2 (NS) and 5 (S-3) of terminal strip AB.
- () Connect a 3300 Ω (orange-orange-red) 1 watt resistor between lugs 3 (NS) and 6 (NS) of terminal strip AB. Position this resistor next to the chassis as shown.
- () Connect a 28 μ h RF choke (#45-18) between lugs 3 (NS) and 6 (S-4) of terminal strip AB.
- () Place a 3/4" length of sleeving on each lead of a 33 Ω (orange-orange-black) 1 watt resistor. Connect this resistor from lug 3 of terminal strip AB (NS) to lug 3 of tube socket V2 (NS).

- (N) Refer to Detail 4A and prepare a 33 Ω (orange - orange - black) 1 watt resistor and 5 μμf disc capacitor combination.

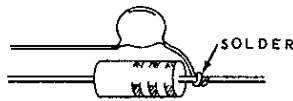

Detail 4A

- (N) Place a 5/8" length of sleeving on the combined resistor and capacitor lead. Connect this lead to lug 3 of tube socket V1 (NS).
- (N) Place a 5/8" length of sleeving on each lead at the other end of this combination. Then connect the resistor lead to lug 3 (S-4) and the capacitor lead to lug 2 (S-4) of terminal strip AB.
- (N) Connect a 200 μμf resin capacitor from lug 3 of tube socket V1 (S-2) to solder lug AA (NS).
- (N) Connect a 2-3/4" red stranded wire from lug 1 of tube socket V1 (S-1) to lug 4 of tube socket V2 (NS).
- (N) Connect a .02 μfd disc capacitor between lugs 4 (S-2) and 2 (NS) of tube socket V2.
- (N) Refer to Detail 4B and mount the pilot lamp socket on the spacer at AA. Use a 6-32 x 1/4" screw and one #6 lockwasher. Position the socket as shown in Pictorial 4.

Detail 4B

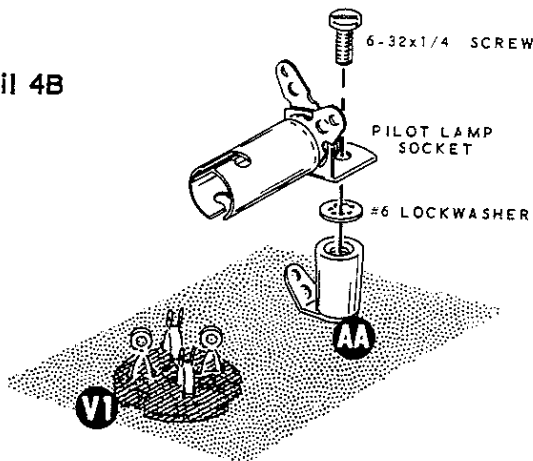

- (N) Connect a 2-1/4" black wire from lug 2 of the pilot lamp socket (S-1) to solder lug AA (S-2).
- (N) Connect a 470 μμf molded capacitor from lug 2 of coil AC (NS) to solder lug AF (NS).

- (N) Connect a 510 μμf molded capacitor from lug 1 of coil AD (NS) to solder lug AF (NS).
- (N) Connect a 310 μμf resin capacitor from lug 2 of coil AD (NS) to solder lug AF (S-3).
- (N) Connect a 360 μμf resin capacitor from lug 2 of coil AL (NS) to solder lug AG (NS).
- (N) Connect a 200 μμf resin capacitor from lug 1 of coil AL (NS) to solder lug AG (NS).
- (N) Connect a 230 μμf resin capacitor from lug 2 of coil AK (NS) to solder lug AG (S-3).
- (N) Connect a 115 μμf resin capacitor from lug 1 of coil AK (NS) to solder lug AH (NS).
- (N) Connect a 290 μμf resin capacitor from lug 2 of coil AJ (NS) to solder lug AH (NS).
- (N) Connect a 115 μμf resin capacitor from lug 1 of coil AJ (NS) to solder lug AH (S-3).
- () Precut the following lengths of black wire. Then prepare each wire by removing 1/4" of insulation from each end. The wire lengths are listed in the order in which they will be used.

3"	2-3/4"	2-1/2"
1-1/2"	2-1/4"	2-1/4"
2-1/2"	2-1/2"	2-1/2"
1-3/4"		

In the following steps connect one end of the prepared black wire to the coil lug specified. Leave the other end free and position it as shown in the Pictorial. This end will be connected later.

CONNECT A

TO

- | | |
|-----------------|-------------------------|
| () 3" wire | lug 1 of coil AJ (S-2). |
| () 1-1/2" wire | lug 2 of coil AJ (S-2). |
| () 2-1/2" wire | lug 1 of coil AK (S-2). |
| () 1-3/4" wire | lug 2 of coil AK (S-2). |
| () 2-3/4" wire | lug 1 of coil AL (S-2). |
| () 2-1/4" wire | lug 2 of coil AL (S-2). |
| () 2-1/2" wire | lug 2 of coil AD (S-2). |
| () 2-1/2" wire | lug 1 of coil AD (S-2). |
| () 2-1/4" wire | lug 2 of coil AC (S-2). |
| () 2-1/2" wire | lug 1 of coil AC (S-1). |

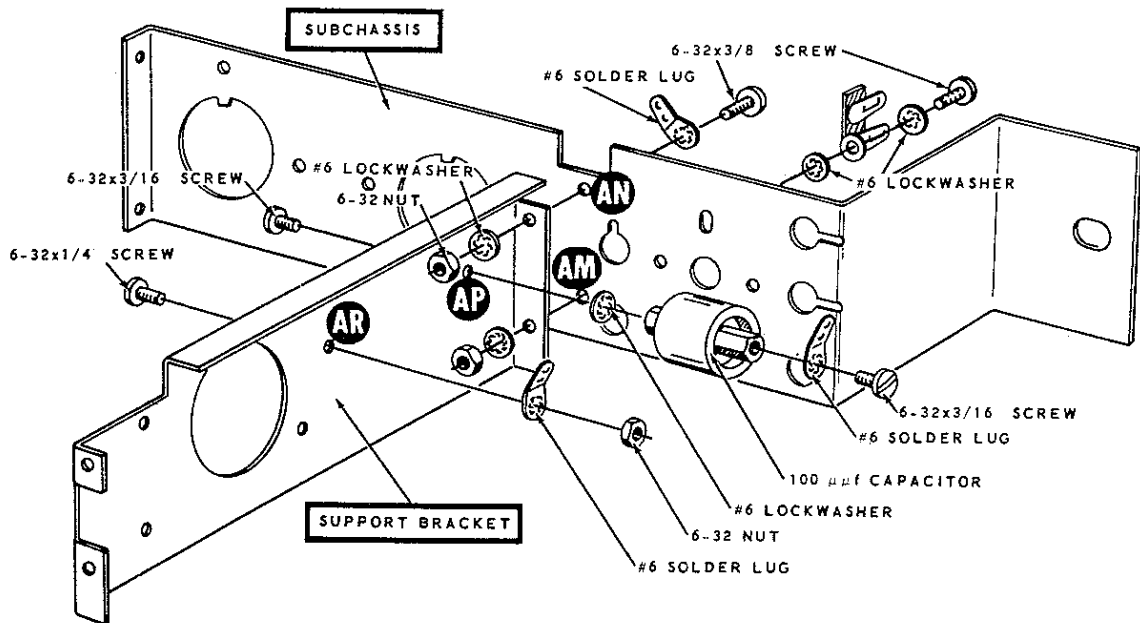

PICTORIAL 5

NOTE: The tube sockets, coils, and other components were omitted from Pictorial 5 for clarity.

Refer to Pictorial 5 for the following steps.

- () Locate the support bracket and position it with the lip and cutouts as shown in Pictorial 5.
- () Mount a #6 solder lug at AR with a 6-32 x 1/4" screw and 6-32 nut.
- () Mount a 100 μf capacitor at AP with a 6-32 x 3/16" screw and #6 lockwasher.
- () Mount a #6 solder lug on top of the 100 μf capacitor at AP with a 6-32 x 3/16" screw.
- () Mount the support bracket to the subchassis with a 2-lug terminal strip at AM and a #6 solder lug at AN. Use 6-32 x 3/8" screws, #6 lockwashers, and 6-32 nuts.

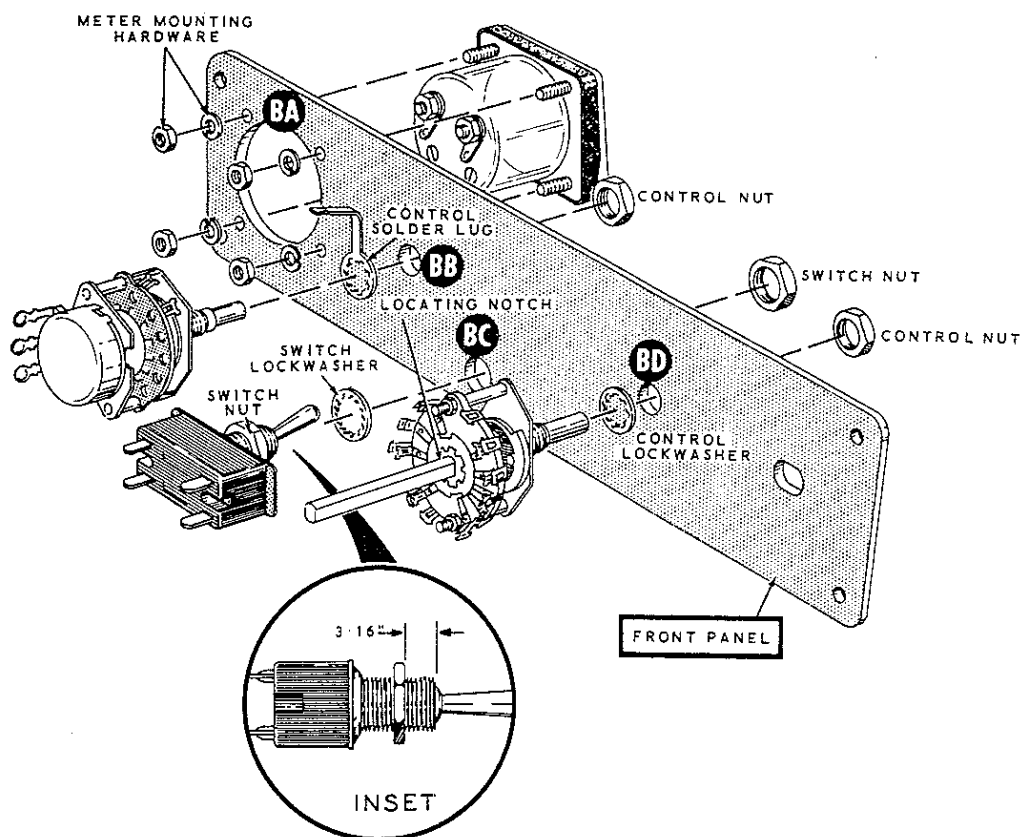

PICTORIAL 6

Refer to Pictorial 6 for the following steps.

- () Carefully remove the meter from its box and remove the shorting wire from between its terminals.
- () Position the front panel on your work area as shown and mount the meter at BA. Be sure that the lettering is right side up and secure the meter with the meter mounting hardware supplied with the meter. Do not overtighten this hardware or you will damage the meter.
- () Mount the switch-control (#63-381) at BB. Use a control solder lug, and control nut. Position the switch-control as shown.
- () Remove one switch nut from the DPST toggle switch. Adjust the remaining switch nut until it is $3/16$ " from the end of the switch bushing. The ON position of the switch is marked on the front of the switch body. When mounting the switch, be sure the ON marking corresponds to the ON marking on the front panel. Mount this switch at BC with the switch lockwasher and the switch nut removed previously.
- () Locate the 5-position 3-wafer rotary switch (#63-374). Be sure the switch shaft is turned fully counterclockwise when viewed from the front. Then remove the rear section.
- () Mount the front portion of this switch at BD with a control lockwasher and control nut. Position the switch so that the locating notch on the wafer is as shown in Pictorial 6. The rear section will be installed later.

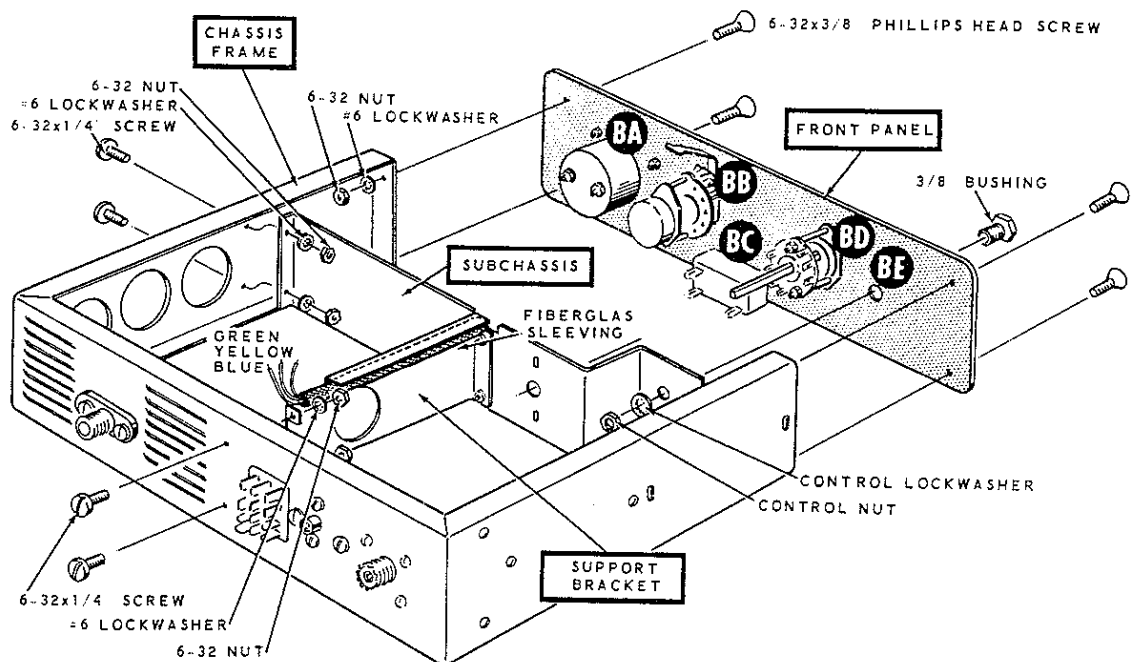

PICTORIAL 7

Refer to Pictorial 7 for the following steps.

- (N) Position the subchassis and support bracket in the chassis frame as shown. Secure the subchassis and support bracket to the side and rear apron of the chassis base with 6-32 x 1/4" screws, #6 lockwashers, and 6-32 nuts.
- () Mount the front panel on the chassis frame as shown in Pictorial 7. Secure each corner of the front panel with 6-32 x 3/8" phillips head screws, #6 lockwashers, and 6-32 nuts.
- () Mount a 3/8" bushing at BE with a control lockwasher and control nut as shown.
- () Place the free ends of the green, yellow, and blue wires extending from terminal strip AB, through the length of fiberglass sleeving. Position the fiberglass sleeving under the lip on the support bracket as shown in Pictorial 7.

Refer to Pictorial 8 (fold-out from Page 19) for the following steps.

- (N) Connect a 7-1/4" black wire from lug 1 of pilot lamp socket AA (S-1) to lug 1 of terminal strip AM (NS).
- () Connect a 3-1/4" black wire from lug 1 of meter BA (NS) to lug 1 of switch-control BB (NS).
- () Connect a 2-1/4" black wire from lug 2 of meter BA (NS) to lug 2 of switch-control BB (S-1).
- (D) Connect a .02 μ fd disc capacitor between lugs 1 (S-2) and 2 (S-2) of meter BA. Position this capacitor as shown.
- (N) Connect a 3" black wire from lug 1 of switch-control BB (S-2) to the solder lug mounted with BB (NS).
- (D) Connect a 1-1/2" black wire from lug 3 of the switch (S-1) to lug 3 of the control (S-1) of switch-control BB.
- (N) Connect a 200 μ mf resin capacitor from lug 3 of tube socket V2⁷ (S-2) to solder lug AN (S-1).

The following steps concern the connection of the free end of the wires extending from coils AC, AD, AJ, AK, and AL.

NOTE: In most cases switch BD has a lug on each side of the wafer at each location. Whenever a wire is connected, place the wire through both lugs and solder both lugs to the wire.

CONNECT THE WIRE FROM	TO LUG OF SWITCH BD
(N) 1 of coil AJ	2 (S-1).
(N) 1 of coil AK	3 (S-1).
(N) 1 of coil AL	4 (S-1).
(N) 2 of coil AD	5 (S-1).
(N) 2 of coil AC	6 (S-1).
(N) 2 of coil AJ	8 (S-1).
(N) 2 of coil AK	9 (S-1).
(N) 2 of coil AL	10 (S-1).

NOTE: The wires from lug 1 of coils AC and AD will be connected later.

- (N) Referring to Detail 8A, prepare an 11-1/2" length of RG-58 coaxial cable (large).
- (N) Place the 1" prepared end of this coaxial cable through the fiberglass sleeving from the front of the chassis. Position the cable so the 1" prepared end reaches relay F on the rear apron.
- (N) At the 1-1/2" prepared end of this coaxial cable, connect the inner lead to lug 7 of switch BD (S-1) and the shield lead to solder lug AE (S-1). The other end will be connected later.
- (N) Remove 1/4" of insulation from one end and 1/2" from the other end of a 10" red wire. Place the 1/2" end of this wire through the fiberglass sleeving as shown.
- (N) Connect the 1/4" stripped end of this wire to lug 1 of terminal strip AM (NS). The other end will be connected later.
- (N) Referring to Detail 8B, prepare both ends of a 17-1/2" and a 14-1/4" RG-174 coaxial cable (small).

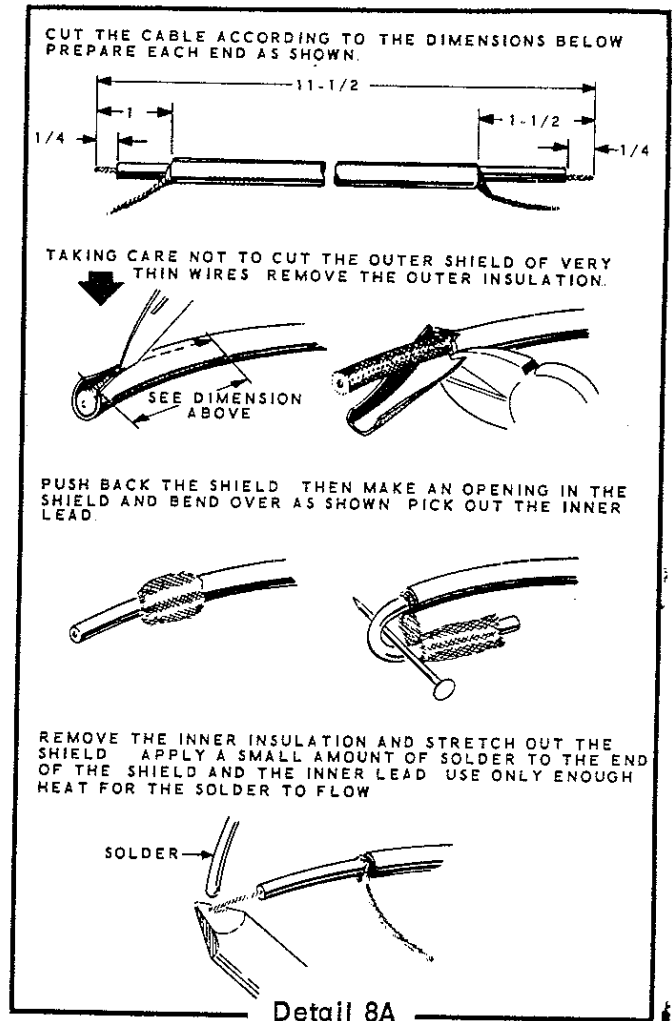

- () Place these two cables through the fiberglass sleeving as shown.
- () Connect the inner lead of the 14-1/4" shielded cable to lug 12 of switch BB (S-1) and the shield lead to the control solder lug at BB (NS).
- () Connect the inner lead of the 17-1/2" shielded cable to lug 11 of switch BB (S-1) and the shield lead to the control solder lug at BB (S-3).
- () Install the pilot lamp in pilot lamp socket AA.

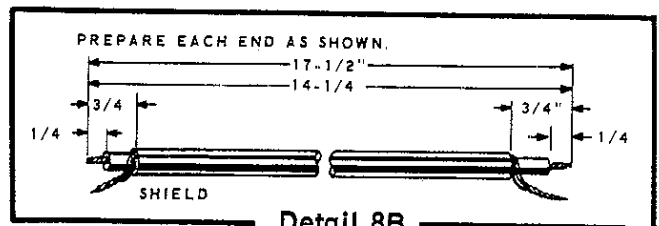

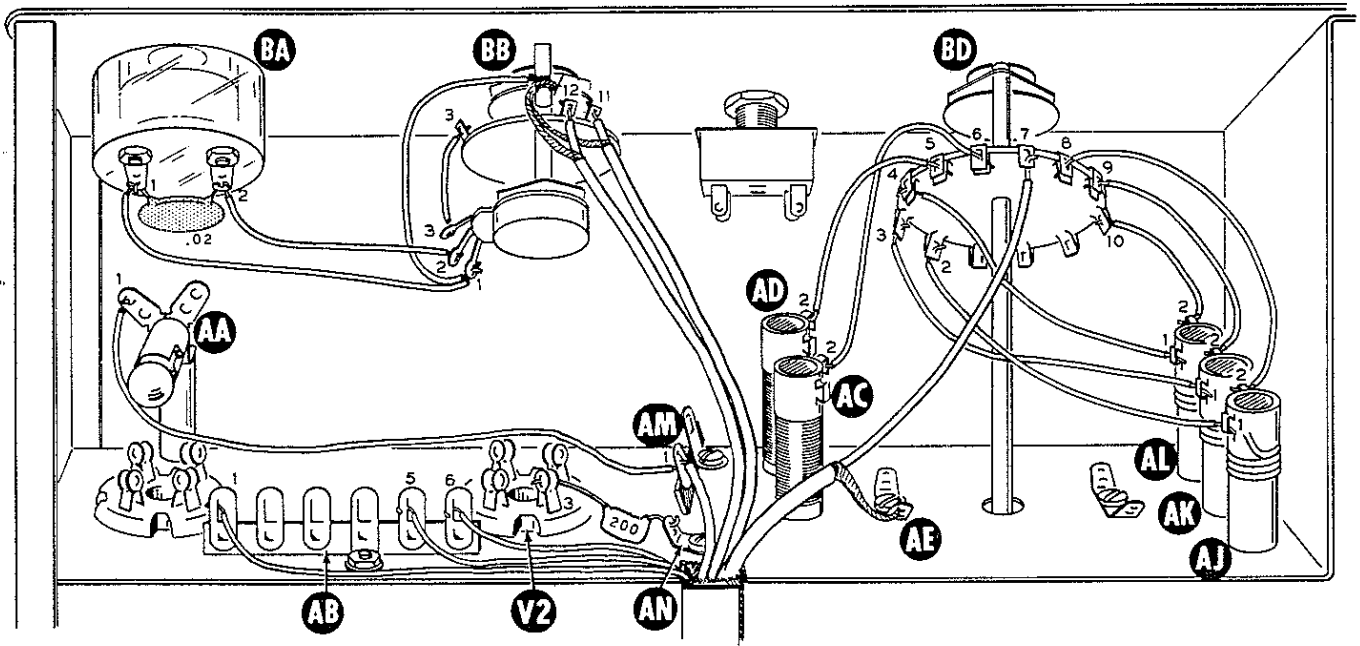

PICTORIAL 8

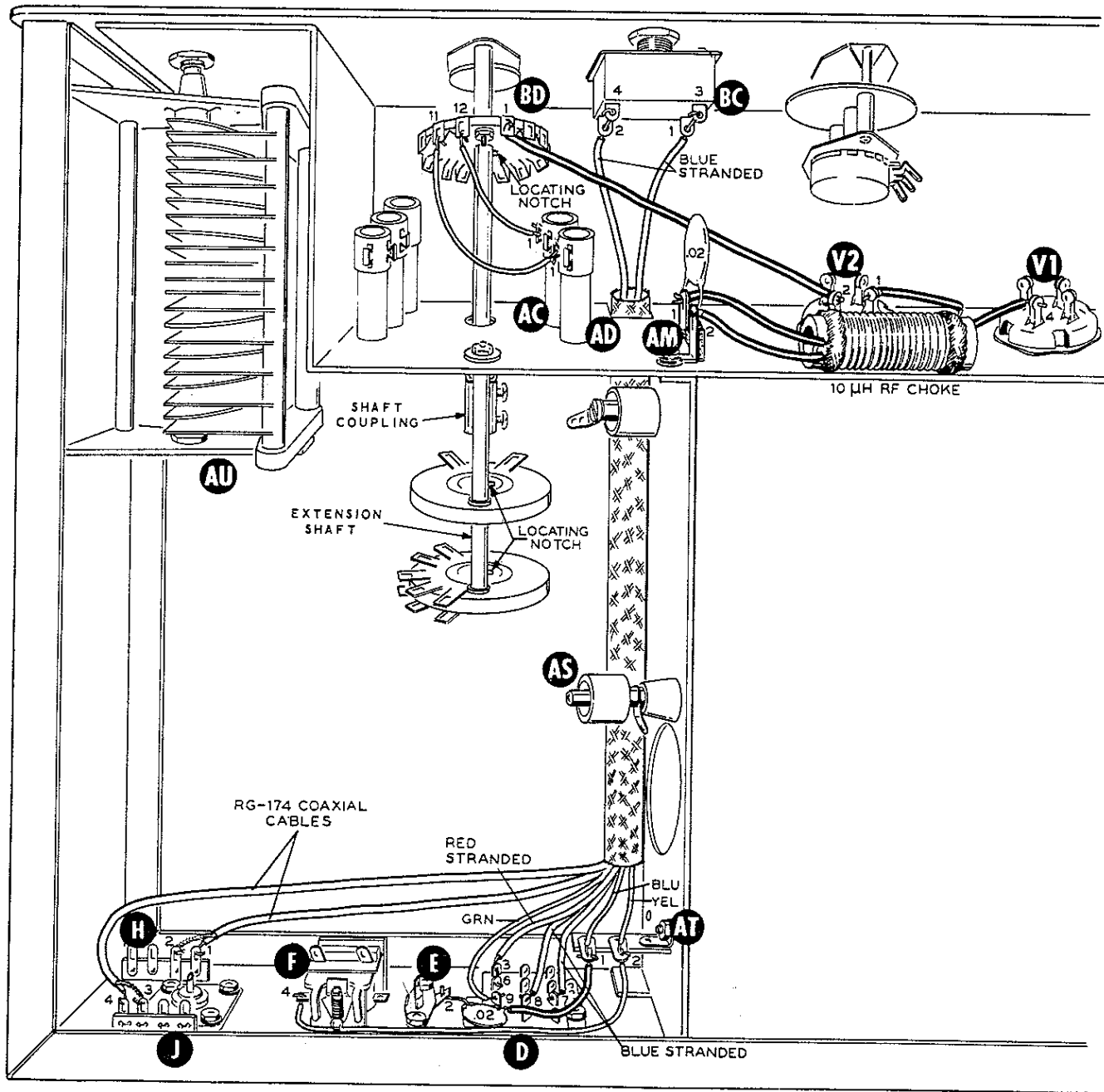

PICTORIAL 9

Refer to Pictorial 9 for the following steps.

- () Turn the chassis over and position it as shown in Pictorial 9.
- () Connect the free end of the wire extending from lug 1 of coil AD to lug 11 of switch BD (S-1).
- () Connect the free end of the wire extending from lug 1 of coil AC to lug 12 of switch BD (S-1).
- () Remove 1/2" of insulation from one end of two 12" blue stranded wires and 1/4" of insulation from the other end of each cable.
- () Place the 1/4" prepared end of these wires through the fiberglass sleeving starting at the subchassis end as shown in Pictorial 9.
- () Place the 1/2" prepared end of either blue stranded wire through lug 2 (S-2) to lug 4 (S-1) of switch BC.
- () Place a 1/2" prepared end of the other blue stranded wire through lug 1 (S-2) to lug 3 (S-1) of switch BC.
- () Connect a 3-1/4" red stranded wire from lug 2 of tube socket V2 (S-2) to lug 1 of switch BD (S-1).
- () Locate the 10 μ h RF choke (#45-60) and place a 1-1/4" length of sleeving on each lead.
- () Position the choke on the subchassis as shown in Pictorial 9. Then connect the lead nearest tube socket V2 to lug 1 of V2 (S-1).
- () Connect the lead nearest tube socket V1 to lug 4 of V1 (S-1).
- () At the other end of this choke, connect either lead to lug 1 (NS) and the other lead to lug 2 (NS) of terminal strip AM.
- () Connect a .02 μ fd disc capacitor between lugs 1 (S-4) and 2 (S-2) of terminal strip AM.
- () Temporarily mount the 2-lug vertical terminal strip at AT. Use a 6-32 x 3/8" screw, two #6 lockwashers, and a 6-32 nut.

The free ends of the wires extending from the end of the fiberglass sleeving near the rear apron will be connected in the following steps.

- (*) Connect the red stranded wire through lug 3 (S-2) to lug 6 (S-1) of power plug D.
- (*) Connect either blue stranded wire to lug 7 (S-1) and the other blue stranded wire to lug 8 (S-1) of power plug D.
- (*) Connect the green wire to lug 9 of power plug D (S-1).
- () Connect the yellow wire to lug 2 of terminal strip AT (NS).
- () Connect the blue wire to lug 1 of terminal strip AT (NS).
- () Connect the inner lead at the free end of the shorter RG-174 coaxial cable (small) to lug 1 (S-3) and the shield lead to lug 2 (NS) of terminal strip H.
- () Connect the inner lead at the free end of the remaining RG-174 coaxial cable (small) to lug 4 (S-3) and the shield lead to lug 3 (S-3) of terminal strip J.

Refer to Detail 9A for the following steps.

- (*) Place the positive (+) lead of a 2 μ fd electrolytic capacitor through the solder lug mounted on power plug D (S-2), through lug 1 (S-2) to lug 2 (S-1) of power plug D. Connect the other lead of this capacitor to lug 2 of terminal strip AT (NS).
- (*) Connect a 4700 Ω (yellow-violet-red) resistor from lug 1 of terminal strip AT (NS) to lug 11 of power plug D (S-1).

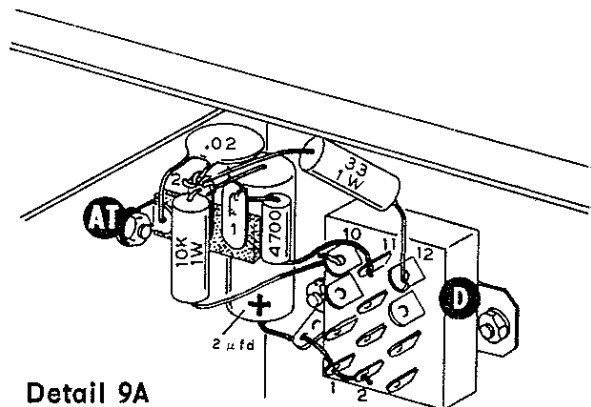

Detail 9A

- (*) Connect a $33\ \Omega$ (orange-orange-black) 1 watt resistor from lug 2 of terminal strip AT (NS) to lug 12 of power plug D (S-2).
- () Connect a $.02\ \mu\text{fd}$ disc capacitor between lug 2 (NS) and the hole in the mounting foot (S-1) of terminal strip AT.
- (*) Connect a $10\ \text{K}\Omega$ (brown-black-orange) 1 watt resistor from lug 2 of terminal strip AT (NS) and lug 10 of power plug D (S-2).

Refer to Pictorial 9 for the following steps.

- () Place a $1/2''$ length of sleeving on one lead of a $.02\ \mu\text{fd}$ disc capacitor. Connect this lead to lug 1 of terminal strip AT (S-3).
- () Connect the other lead of this capacitor to lug 2 of phono socket E (S-2).
- () Connect a 5" yellow wire from lug 2 of terminal strip AT (S-6) to lug 4 of relay F (S-1).
- () Refer to Detail 9B and mount the variable capacitor (#26-96) at AU. Use 6-32 x $3/8''$ screws, #6 lockwashers, and 6-32 nuts. NOTE: The mounting holes for variable capacitor AU and the bushing hole in the front panel are slotted. Adjust the capacitor and bushing so that the capacitor shaft turns freely.

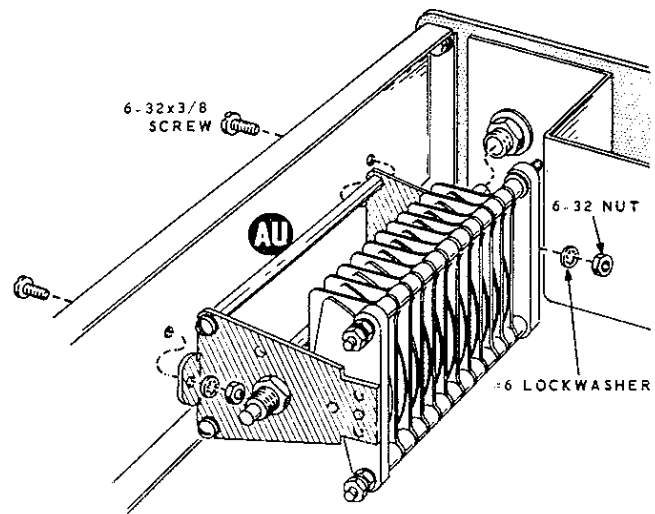

Detail 9B

- () Locate the rear section of the 5-position switch (#63-374). Remove one nut and a lockwasher from each switch stud. Mount the rear switch section to the subchassis as shown in Detail 9C. Position the switch lugs and locating notch as shown in Pictorial 9. Secure the switch section with #6 flat washers and the nuts and lockwashers removed previously.
- () Start a setscrew in one of the knobs and install this knob on the shaft of the BAND switch. Rotate the switch shaft. If it does not turn freely, adjust the rear section of the switch for free movement of the switch shaft. When the switch is turned full counterclockwise, the knob pointer should be at 80 on the front panel.

- () Start two 6-32 x $1/4''$ screws in the shaft coupling. Refer to Detail 9C. Install one end of the shaft coupling on the Band switch shaft, and the other end of the coupling on the extension shaft.

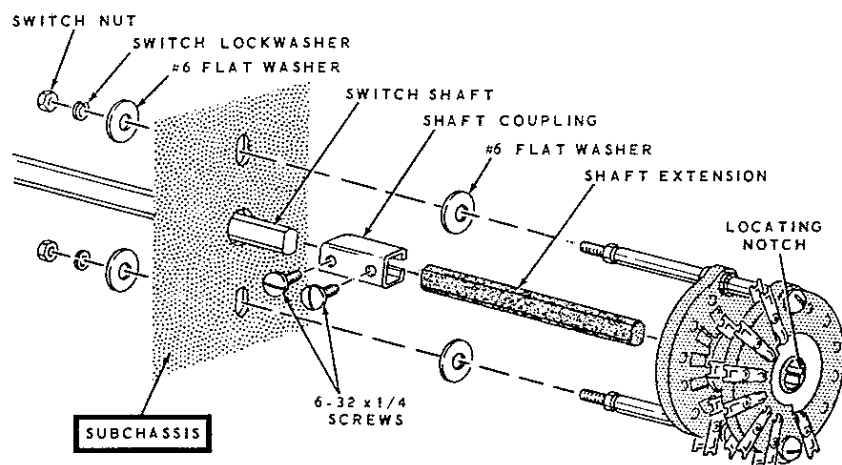

Detail 9C

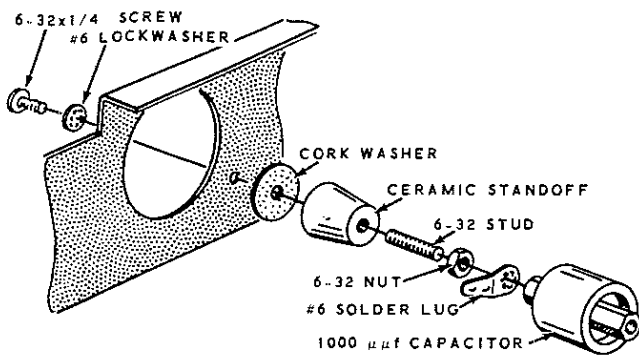

Detail 9D

- () Referring to Detail 9D, screw the 6-32 stud into a 1000 $\mu\mu\text{f}$ (.001 μfd) tubular capacitor. Place a #6 solder lug over the stud and secure it with a 6-32 nut. Hold the base of the capacitor with long-nose pliers and tighten the nut securely.
- () Remove the hardware from the top of the ceramic insulator and discard it. Screw the 6-32 stud installed in the previous step into the top of the ceramic insulator.
- () Mount the ceramic insulator and capacitor at AS with a 6-32 x 1/4" screw, a #6 lockwasher and the cork washer supplied with the insulator. Position the solder lug as shown in Pictorial 9. Discard the screw and flat washer supplied with the insulator.

Refer to Pictorial 10 (fold-out from Page 27) and Detail 10A for the following steps.

- () Mount a #6 solder lug at AV on the input shield (#206-M275). Use a 6-32 x 1/4" screw and a 6-32 nut.
- () Mount a 350 $\mu\mu\text{f}$ tubular capacitor at AW with a 6-32 x 3/16" screw, and a #6 lockwasher.
- () Mount a #6 solder lug on top of capacitor AW. Use a 6-32 x 3/16" screw.
- () Turn the chassis over and position it as shown in Pictorial 10.
- () Temporarily remove the hardware securing terminal strip AT.
- () Mount the input shield on the chassis as shown in Detail 10A and Pictorial 10.

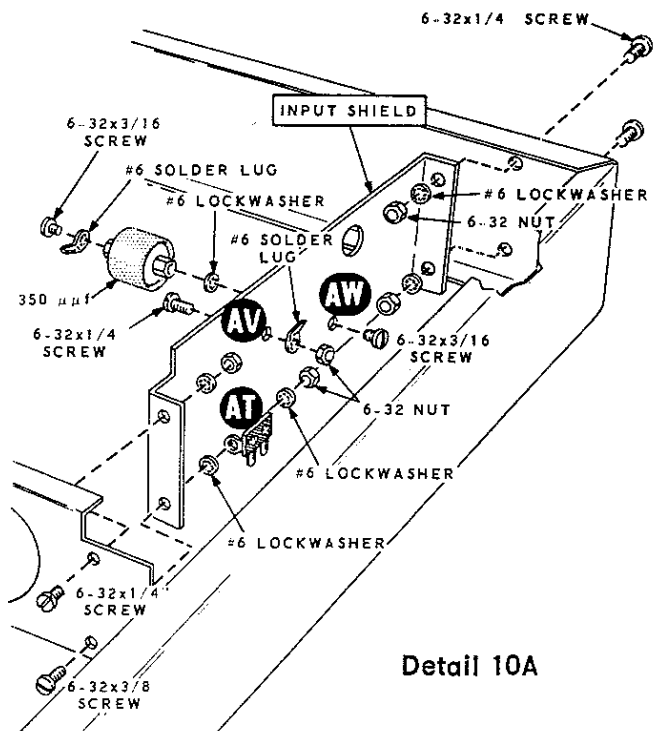

Detail 10A

Secure the input shield and terminal strip at AT with the hardware removed previously. Secure the remaining three corners of the input shield with 6-32 x 1/4" screws, #6 lockwashers, and 6-32 nuts.

- () Locate the 80, 40, and 20 meter output tank coil (#40-597) and mount a 15/32" spacer on each end as shown in Detail 10B. Use 6-32 x 1/4" screws.
- () Referring to Detail 10B, mount the 80, 40, and 20 meter output tank coil at AX with 6-32 x 1/4" screws and #6 lockwashers. Position the end with the four turn coil near variable capacitor AU.

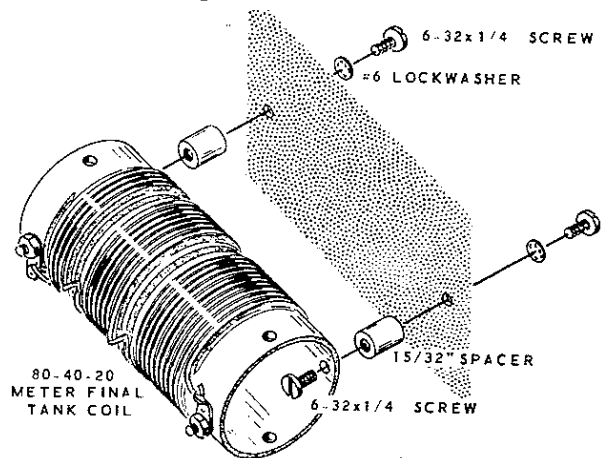

Detail 10B



- (f) Connect the shield lead of the RG-58 coaxial cable, extending from the fiberglass sleeving, to solder lug AV (S-1) and the inner lead to lug 7 of relay F (S-1).
- (f) Connect a 1-1/8" bare wire between lugs 5 (S-1) and 6 (S-1) of relay F. Be sure this lead does not touch the metal input shield.
- (f) Place one end of a 2-1/2" bare wire through the large hole in the input shield, through lug 1 of coil AX (S-2) to solder lug on capacitor AW (NS). Connect the other end of this wire to lug 8 of relay F (S-1).
- (f) Wrap one lead of a 1.1 mh choke around the wire connected to lug 8 of relay F (S-1). Connect the other lead to lug 2 of terminal strip H (S-4).

NOTE: The bare wire is too large to fit into the switch lugs. Therefore the end going to the switch lugs should be flattened as shown in Detail 10C. Pass the wire through both lugs at each position on the switch. Do not attempt to bend this wire around the coil or switch lugs as the coil or switch could be damaged. When soldering connections at switch BD, be sure to solder both lugs at each connection.

- (f) Connect a bare wire from lug 4 of coil AX (S-1) to lug 9 on wafer C of switch BD (NS). Pass the wire through both lugs of the switch and let it extend 1/4" beyond the switch lug.

- (f) Position the 10 and 15 meter final tank coil behind switch BD as shown in Pictorial 10. Secure the end of the coil with the mounting lug to capacitor AS with a #6 solder lug and 6-32 x 3/16" screw.

- (f) Connect the other end of the 10 and 15 meter final tank coil to lug 9 on wafer C of switch BD (NS). Place the coil wire between the two lugs. Bend the 1/4" lead of the bare wire extending from lug 9 as shown in the inset drawing and solder lug 9 (S-2).

- (f) Connect the lead extending from the center of the 10 and 15 meter final tank coil to lugs 8 on wafer C of switch BD (S-1).

- () Place a #6 solder lug on bolt 1 of variable capacitor AU. Secure the solder lug with a 6-32 nut.

- (f) Connect a bare wire from lug 1 of variable capacitor AU (S-1) to lug 8 of wafer B on switch BD (S-1).

- (f) Connect a 1" bare wire from lug 5 on wafer B of switch BD (S-1) to capacitor AP (S-1).

- (f) Connect a 500 μmf molded capacitor from lug 6 on wafer C of switch BD (S-1) to solder lug AR (S-1).

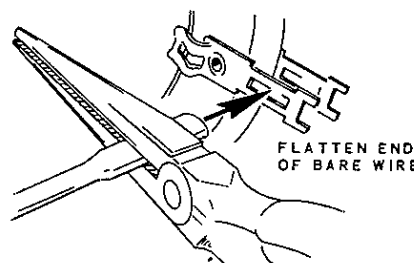

Detail 10C

- () Cut off the end of each anode clip as shown in Detail 10D.

- () Referring to Detail 10D, connect the two parasitic chokes in series. Connect the free end of each choke to an anode clip and solder the connection.

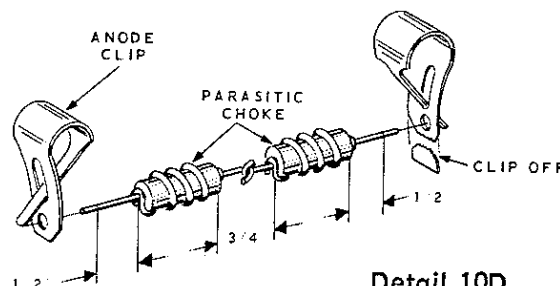

Detail 10D

- (f) Install the two tubes in tube sockets V1 and V2. The two large tube base pins fit into the large tube socket holes. Snap the tube clamps around the bases of the tubes.

- () Install the anode clip on the plate caps of the tubes.

- (f) Connect a 3-1/2" bare wire from lug 2 of RF choke C (NS) to the solder lug between the ceramic insulator and 1000 μmf capacitor at AS (S-1). CAUTION: Be sure this wire does not touch the metal support bracket.

- (f) Connect a 3" bare wire from lug 2 of RF choke C (S-2) to the point between the two parasitic chokes as shown in Pictorial 10. Crimp this wire tightly and solder the connection.

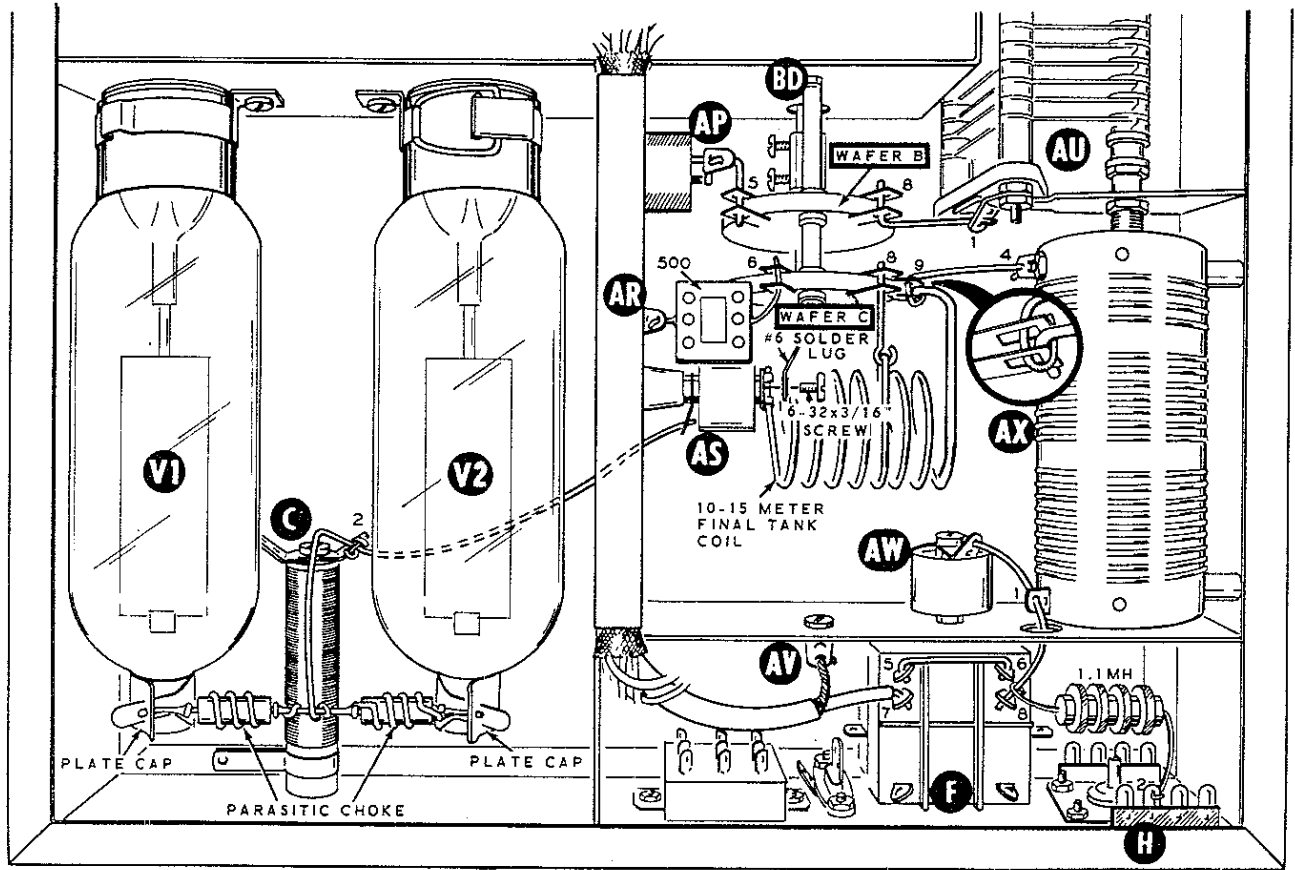

PICTORIAL 10

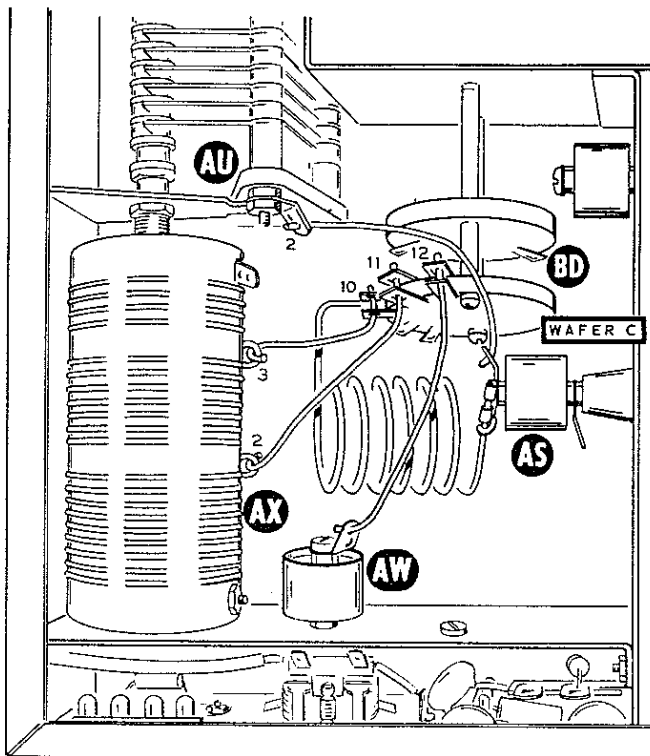

PICTORIAL 11

Refer to Pictorial 11 for the following steps.

- () Turn the chassis over and position it as shown in Pictorial 11.
- () Connect a 1-3/4" bare wire from lug 3 of coil AX (S-1) to lug 10 on wafer C of switch BD (S-1).
- () Connect a 2-1/2" bare wire from lug 2 of coil AX (S-1) to lug 11 on wafer C of switch BD (S-1).

- () Connect a 3" bare wire from capacitor AW (S-2) to lug 12 on wafer C of switch BD (S-1).
- () Mount a #6 solder lug on lug 2 of variable capacitor AU. Secure the solder lug with a 6-32 nut.
- () Connect a 3" bare wire from lug 2 of variable capacitor AU (S-1) to the solder lug on capacitor AS (S-1).

This completes the assembly of your Heathkit HA-14 SSB Linear Amplifier. Shake out all wire clippings and solder splashes. Check to be sure all connections have been properly soldered.

Refer to Pictorial 12 for the following steps.

- () Start setscrews into the remaining two knobs.
- () Turn the TUNE capacitor until the plates are fully meshed. Install a knob on the TUNE capacitor shaft with the pointer at the 9 o'clock position.

Refer to Detail 12A for the following steps.

- () Turn the outer shaft on the METER control fully counterclockwise. Install the lever knob on the outer shaft with the pointer at FWD. Tighten the setscrew with the allen wrench supplied. Do not overtighten or the outer shaft will bend causing the shafts to bind.

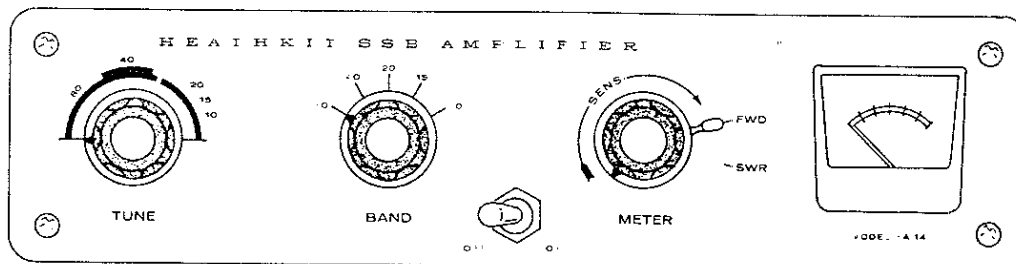

PICTORIAL 12

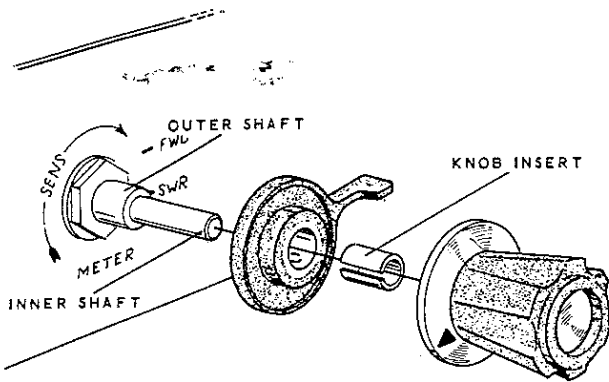

Detail 12A

- () Turn the inner shaft of the METER control fully counterclockwise. Place the knob insert in the remaining knob and install the knob on the inner shaft of the METER control. Set the pointer at the 7 o'clock position.
- () Referring to Pictorial 13 prepare a length of RG-58 coaxial cable long enough to reach from the RF output of the exciter to the RF INPUT of the Linear Amplifier. Install a phono plug on one end and the proper connector to match your exciter output on the other end.

NOTE: If it is necessary to install a coaxial connector to any of the cables, refer to Pictorial 14 for proper installation.

PREPARE ONE END AS SHOWN

SEE DIMENSION ABOVE

SOLDER

SOLDER

PICTORIAL 13

PICTORIAL 14

NOTE: The following steps concern the power socket wiring for the Linear Amplifier. Pictorial 15 shows the correct wiring for DC operation and Pictorial 16 shows the correct wiring for use with the AC power supply. If both plugs are wired, they should be labeled to avoid mixing them after they are wired.

DC POWER SOCKET WIRING

Refer to Pictorial 15 for the following steps.

- () Prepare one end of two lengths of the RG-174 coaxial cable as shown in Detail 15A. These cables must be long enough to reach from the Linear Amplifier to the exciter.

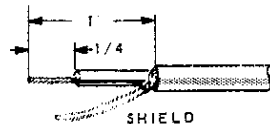

Detail 15A

- () Prepare the free end of the 8-wire cable from the mobile power supply as shown in Detail 15B. Cut the orange, white, and brown wires off as they are not used.
- () Place the free end of this 8-wire cable and the two RG-174 coaxial cables through the hole in the top of the female power socket cover.

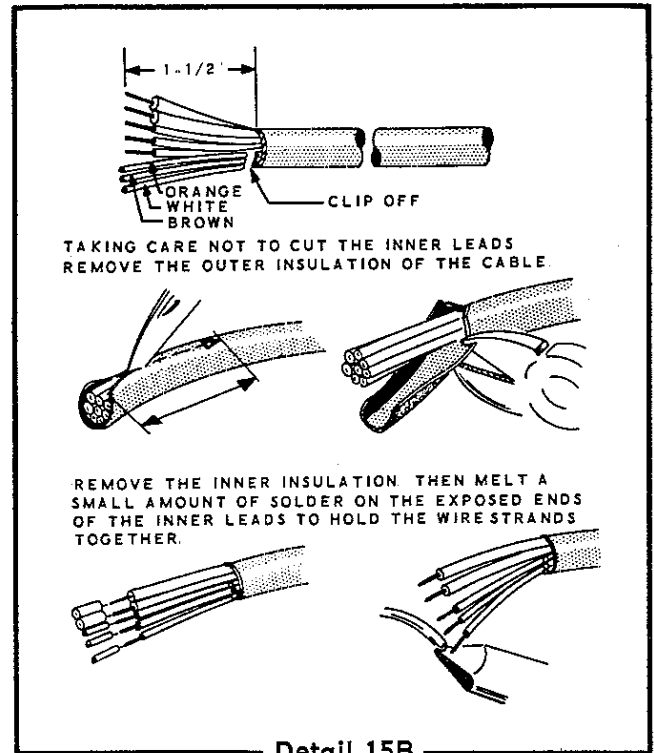

Detail 15B

Connect the wires at the prepared end of the 8-wire cable as follows:

- () Black through lug 1 (S-2) to lug 2 (S-1).
- () Red through lug 6 (S-2) to lug 3 (S-1).
- () Blue to lug 8 (S-1).
- () Yellow to lug 9 (S-1).
- () Green to lug 10 (S-1).

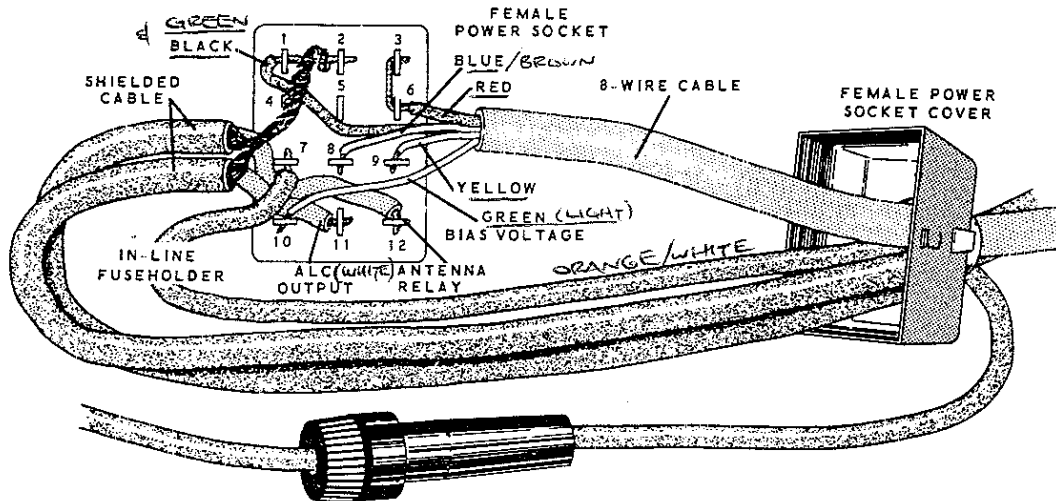

PICTORIAL 15

- () Connect the inner lead of either coaxial cable to lug 12 (S-1) and the shielded lead to the wire between lugs 1 and 2 (NS). Mark this lead as the Antenna Relay lead.
- () Connect the inner lead of the remaining coaxial cable to lug 11 (S-1) and the shield lead to the wire between lugs 1 and 2 (S-2). Mark this lead as the ALC lead.
- () Locate the in-line fuseholder supplied with the HP-14 Power Supply. Cut the lead extending from the body end of the fuseholder to 8" and remove 1/4" of insulation.
- () Place this prepared end of the fuseholder lead through the hole in the top of the female socket cover. Connect this lead to lug 7 of the power socket (S-1). The other end of this wire is connected to the automobile ignition switch. See the HP-14 Manual.
- () Refer to Detail 15C and place the female power socket into the socket cover. Line up the small holes in the socket cover with the holes in the socket. Insert the drive pin through the holes and lightly tap it in place.
- () Tighten the screws on the socket cover clamp to secure the cables.
- () Install a phono plug or appropriate connector on the free end of the RG-174 coaxial cables extending from the power socket.
- () Mount the high voltage cap on the free end of the high voltage wire coming from the DC Power Supply.

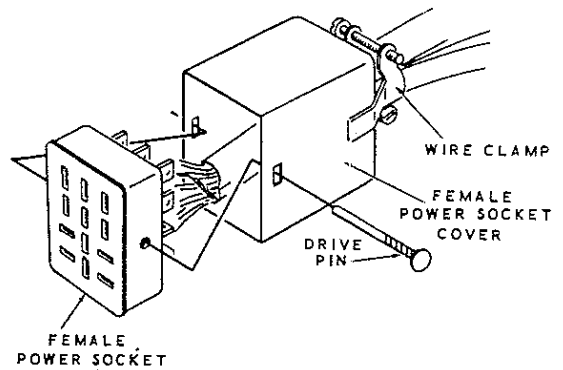

Detail 15C

AC POWER SOCKET WIRING

Refer to Pictorial 16 for the following steps.

- () Prepare one end of two lengths of the RG-174 coaxial cable as shown in Detail 16A. These cables must be long enough to reach from the Linear Amplifier to the exciter.

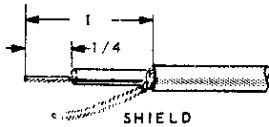

Detail 16A

- () Prepare the free end of the 8-wire cable from the AC Power Supply as shown in Detail 16B.
- () Place the free end of the 8-wire cable and the RG-174 coaxial cables through the hole in the top of the female power socket cover.

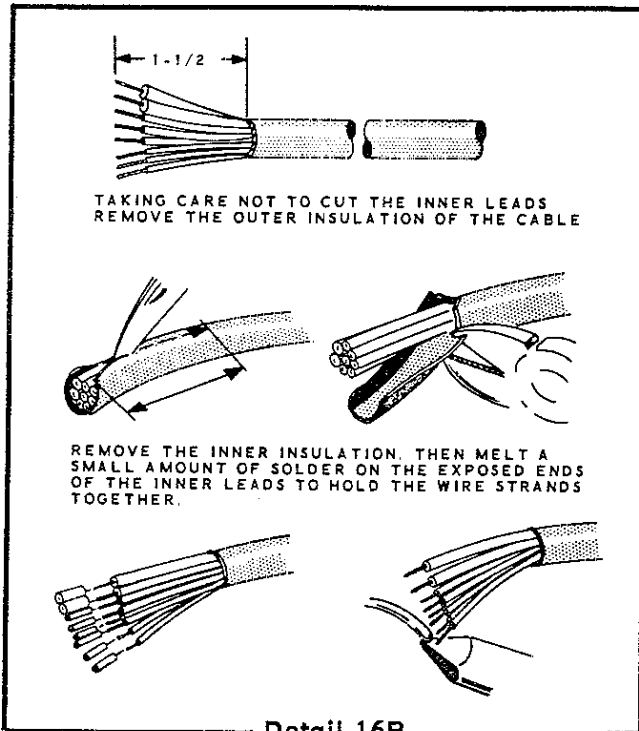

Detail 16B

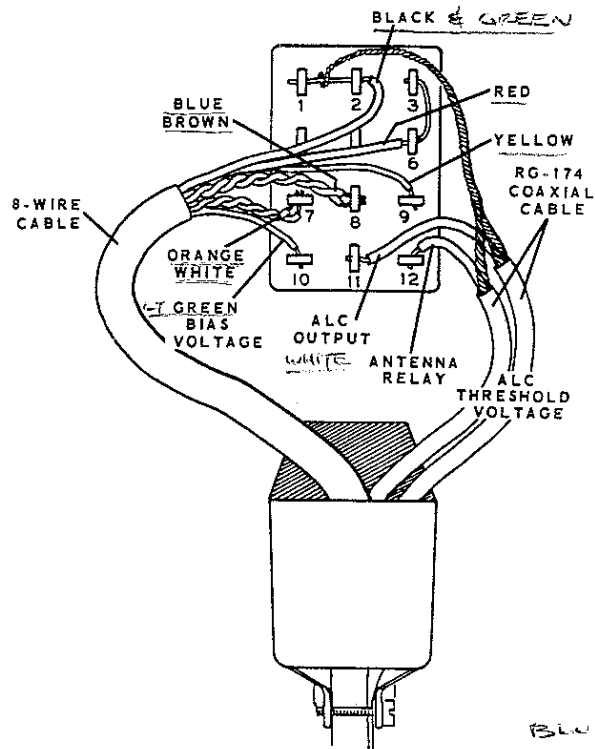

PICTORIAL 16

Connect the wires at the prepared end of the 8-wire cable as follows:

- () Black through lug 2 (S-2) to lug 1 (S-1).
- () Red through lug 6 (S-2) to lug 3 (S-1).
- () Yellow to lug 9 (S-1).
- () Twist the blue and brown wires together and connect both wires to lug 8 (S-2).
- () Twist the orange and white wires together and connect both wires to lug 7 (S-2).
- () Green to lug 10 (S-1).
- () Connect the inner lead of either coaxial cable to lug 12 (S-1) and the shield lead to the wire between lugs 1 and 2 (NS). Mark this lead as the Antenna Relay lead.

-) Connect the inner lead of the remaining coaxial cable to lug 11 (S-1) and the shield lead to the wire between lugs 1 and 2 (S-2). Mark this lead as the ALC lead.
- () Refer to Detail 16C and place the female power socket into the power socket cover. Line up the small holes in the socket cover with the holes in the socket. Insert the drive pin through the hole and lightly tap it in place.
- () Tighten the screws on the socket cover clamp to secure the cables.
- () Install a phono plug or appropriate connector on the free end of the RG-174 coaxial cables extending from the power socket.

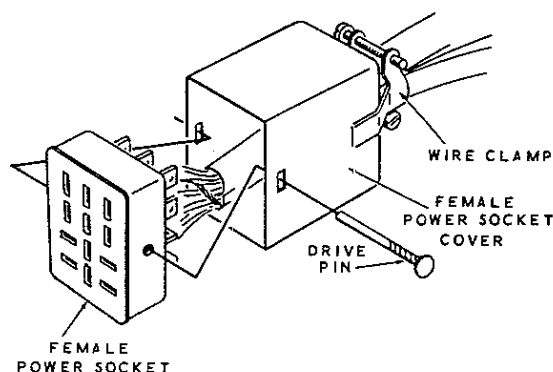

Detail 16C

- () Mount the high voltage cap on the free end of the high voltage wire coming from the AC Power Supply.

RESISTANCE CHECKS

The input coils are factory adjusted and do not require any further alignment.

Measure the resistance from the pins on the power plug to chassis ground. The following

readings were taken with an 11 megohm input VTVM.

If any difficulty is encountered in obtaining any of the following resistance readings, refer to the In Case of Difficulty section on Page 36.

POWER PLUG PIN NUMBER	RESISTANCE MEASURED	POWER PLUG PIN NUMBER	RESISTANCE MEASURED
1	0	Between pins 7 and 8	inf. power switch off 0 power switch on
2	0	Between pins 10 and 12	1500 Ω
3	0	HV socket to chassis	inf.
4	inf.	RF input socket to chassis	inf.
5	inf.	RF output socket to chassis	inf.
6	0	RF input socket to RF output socket	0
7	inf.		
8	inf.		
9	inf.		
10	over 3 megohms after 10 seconds		
11	inf. after 3 seconds		
12	over 3 megohms after 10 seconds		

CAUTION: LETHAL VOLTAGES ARE PRESENT IN THIS UNIT. USE EXTREME CARE WHEN MAKING ANY TEST WITH THE POWER ON.

INITIAL TEST

NOTE: The following tests are made without high voltage from the Power Supply connected to the Linear Amplifier.

- (*) Plug the power cable socket onto the POWER plug on the rear apron of the Linear Amplifier. Connect the other end of this cable to the Power Supply. DO NOT connect the high voltage lead.
- (*) Connect the Power Supply to the appropriate power source. Turn ON the Linear. The pilot lamp and tube filaments should light.
- () Using a 20,000 ohm/volt meter or VTVM, measure the voltage at pin 3 of tubes V1 and V2. This voltage should be approximately -120 volts DC, using the HP-14 and approximately -150 volts DC using the HP-24. If not, refer to the In Case Of Difficulty section on Page 36.
- (*) Touch the center pin of the Antenna Relay coaxial cable to the chassis. CAUTION: DO NOT touch the center pin with your hand as it has -120 volts DC present. When this point touches the chassis the antenna relay should close.
- () With the antenna relay closed, again measure the voltage at pin 3 of tubes V1 and V2. It now should be approximately -2 volts DC.
- () Turn the power supply off and disconnect the power cable from the Linear Amplifier.

This completes the Initial Test. Continue with Final Assembly.

FINAL ASSEMBLY

Refer to Pictorial 17 for the following steps.

NOTE: Two different sizes of rubber feet are provided to permit various types of installations. The method described in this section permits a slight backward tilt of the Linear Amplifier for easy operation of the controls. Three different suggestions for mobile mounting are shown on Page 32. If the Linear Amplifier is mounted to another unit, use the short rubber feet and

the 6-32 x 5/8" screws. The seams of the cabinet should be placed on the bottom.

- () Mount a short rubber foot on each rear corner of the cabinet. Measure in from the side and rear of the cabinet as shown. Secure the feet with a 6-32 x 3/8" screw, a #6 flat washer, a #6 lockwasher, and a 6-32 nut. The screw passes through the perforated holes in the cabinet. These dimensions are approximate.

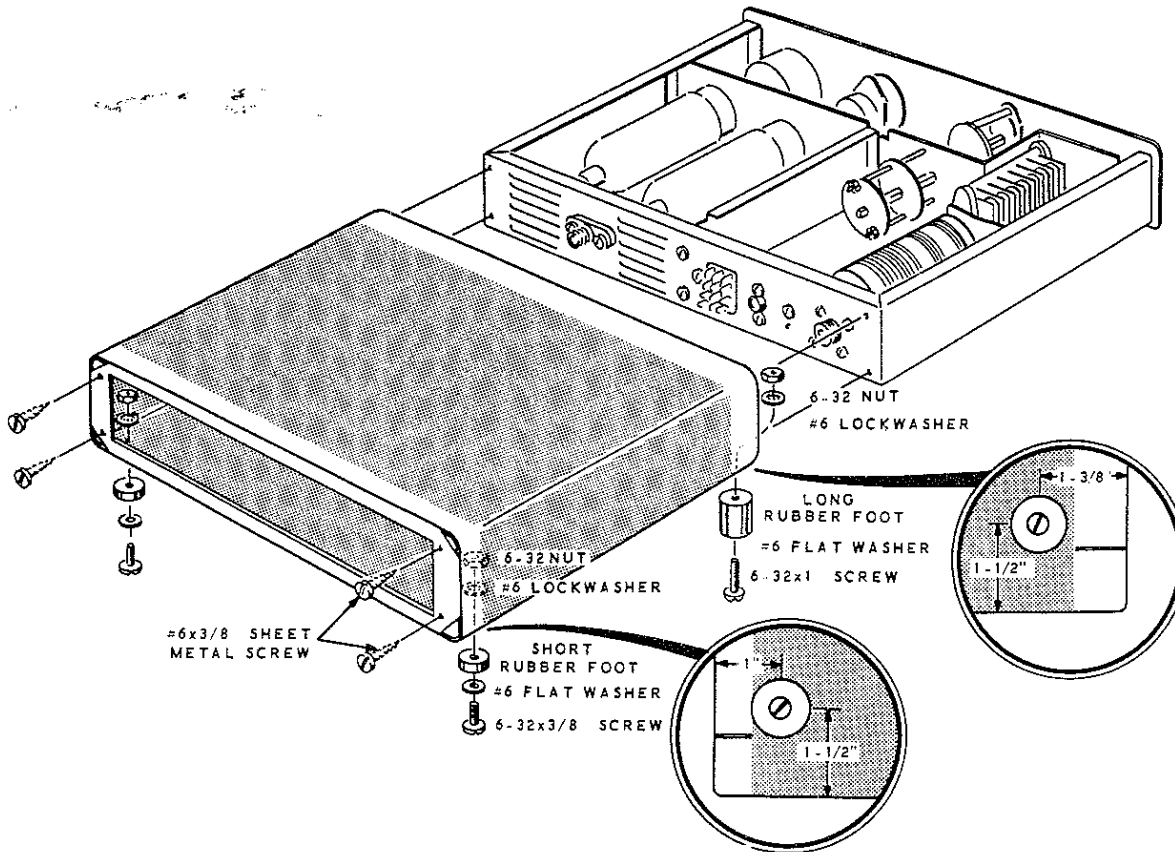

PICTORIAL 17

- () Mount a long rubber foot on each front corner of the cabinet. Measure in from the side and front of the cabinet as shown. Secure each foot with a 6-32 x 1" screw, #6 flat washer, #6 lockwasher, and a 6-32 nut.
- () Slide the chassis into the cabinet.
- () Secure the chassis to the cabinet with #6 x 3/8" sheet metal screws.

any communications with the Heath Company; this assures you that you will receive the most complete and up-to-date information in return.

- () Install the identification label in the following manner:
 1. Select a location for the label where it can easily be seen when needed, but will not show when the unit is in operation. This location might be on the side of the chassis frame.
 2. Carefully peel away the backing paper. Then press the label into position.

NOTE: The blue and white identification label shows the Model Number and Production Series Number of your kit. Refer to these numbers in

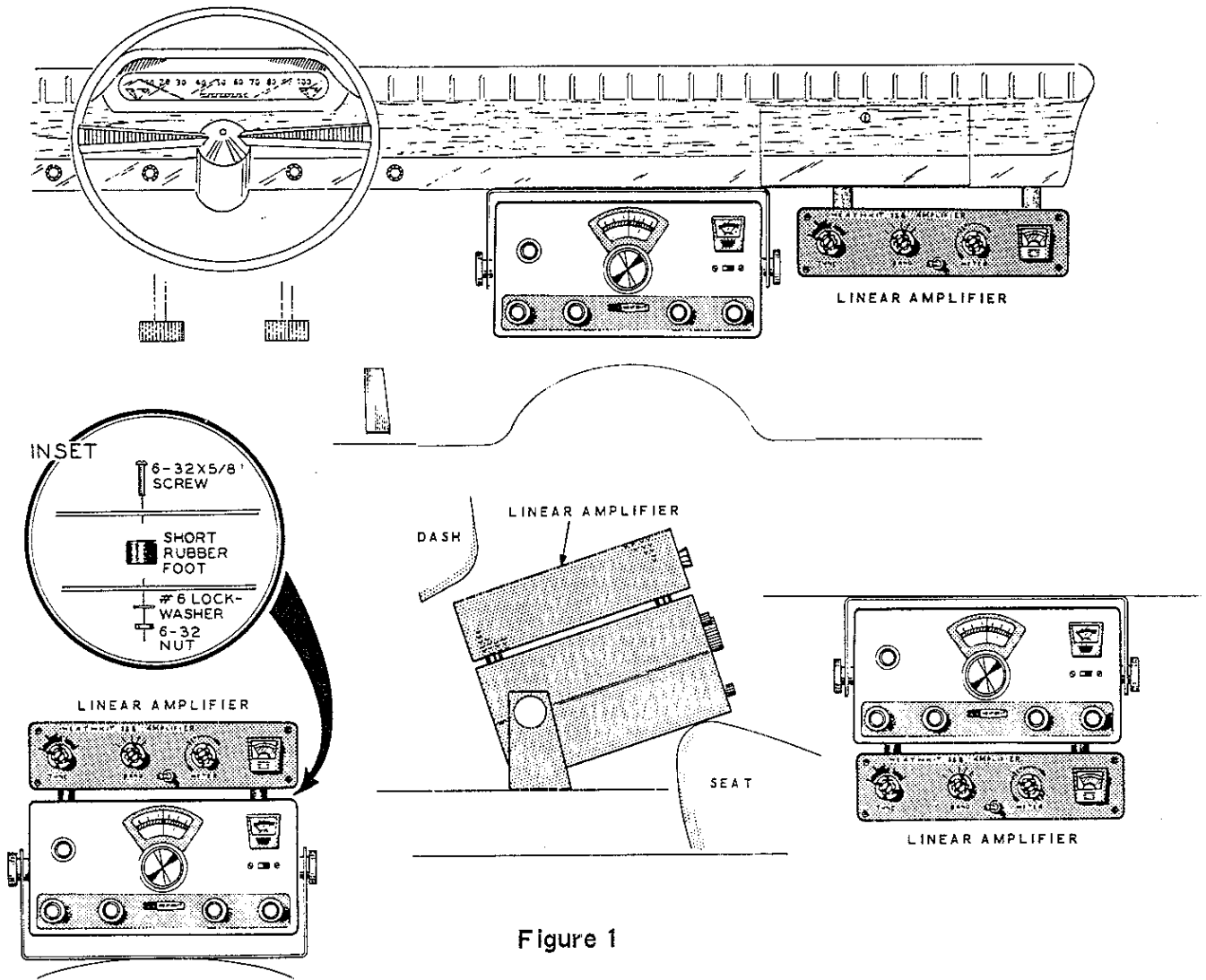

Figure 1

INSTALLATION

LOCATION

The tubes in the Linear Amplifier generate considerable heat, therefore, the unit should be mounted in a location that will allow good air circulation. This applies to both mobile and fixed station installations. Three suggested mobile installations are shown in Figure 1.

POWER SOURCE

The Linear Amplifier is designed to operate from a 2400 V DC voltage source. This can either be a transistorized mobile power supply or an AC fixed station supply. Use the proper power socket wired previously.

SB-400
TRANSMITTER

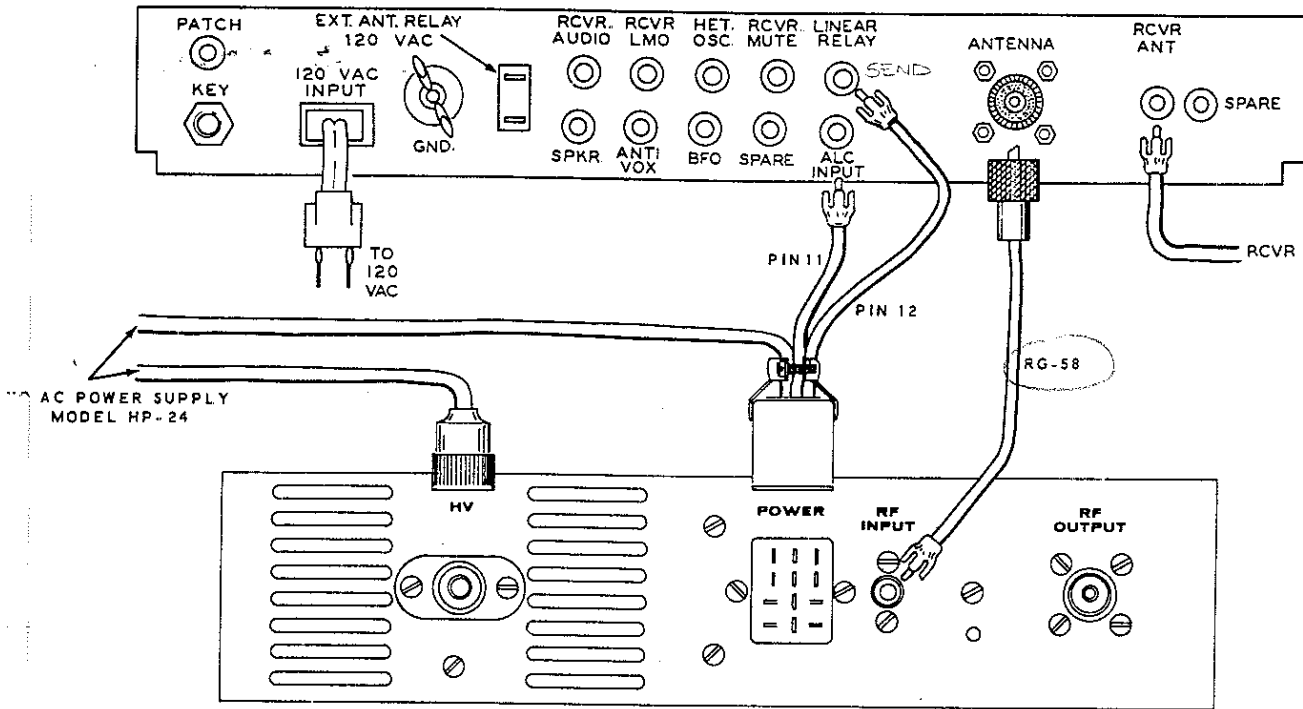

Figure 2

EXCITER

The Linear Amplifier can be driven by most commercial or home-built exciters with a power output of approximately 100 watts. The Heathkit HW-12, HW-22, and HW-32 Transceivers and the SB-400 Transmitter are ideal for use with this Linear Amplifier. Some modifications to the HW-12, HW-22, and HW-32 Transceivers are necessary. See Figure 3A. Exciters with an output in the 40 to 60 watt range can be used to drive the Linear Amplifier, however, the full power capabilities of the Linear Amplifier cannot be used.

Every effort should be made to get the SWR of the antenna down to less than 2 to 1.

A mobile antenna rated at 1000 watts is recommended for use with the Linear Amplifier. However, satisfactory results have been obtained from some antennas of a lower rating. If an antenna is used with less than a 1000 watt rating corona may appear at the tip of the antenna while it is being used. Corona can be eliminated by using a larger metal ball at the tip of the antenna.

WARNING! When there is RF output from the Linear during transmit, a high voltage appears on the antenna. Do not transmit when anyone is near the antenna.

ANTENNA

The pi-network output is designed to work into a 50 Ω line with an SWR not to exceed 2 to 1.

INTERCONNECTIONS

Figure 2 shows how to connect the Linear Amplifier to the Heathkit SB-400 Transmitter.

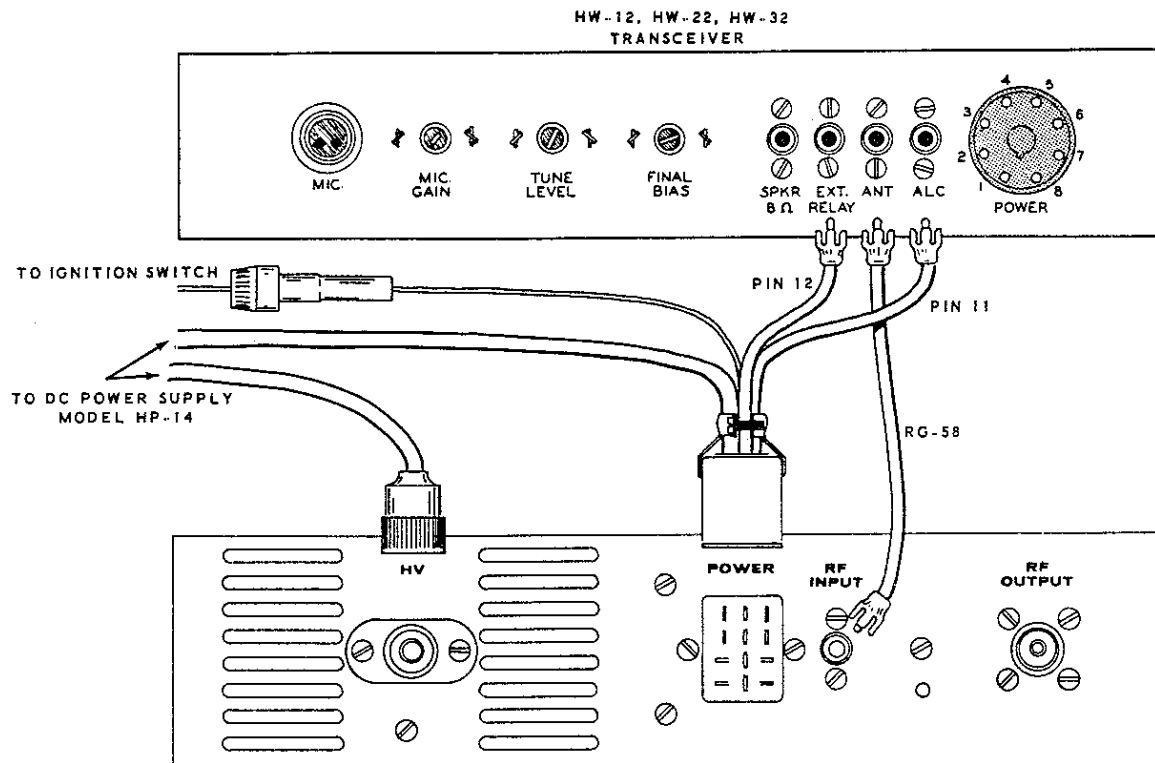

Figure 3

Figure 3 shows how to connect the Linear Amplifier to the Heathkit HW-12, HW-22, and HW-32 Transceivers. In order to use the Linear Amplifier with these Transceivers, it is necessary to slightly modify the Transceiver for external ALC. If the Linear Amplifier is used with a transceiver without ALC, wrap insulating tape around the phono plug to prevent shorting.

HW-12, HW-22, HW-32 Modification

NOTE: The Linear Amplifier has a built in antenna relay, therefore, the RCVR jack on the Transceiver is not needed. This jack will be used for the external ALC output. Refer to Figure 3A and the following instructions for this modification.

- () Mount the 1-lug terminal strip, supplied with the Linear Amplifier, on one mounting screw of the RCVR jack as shown.

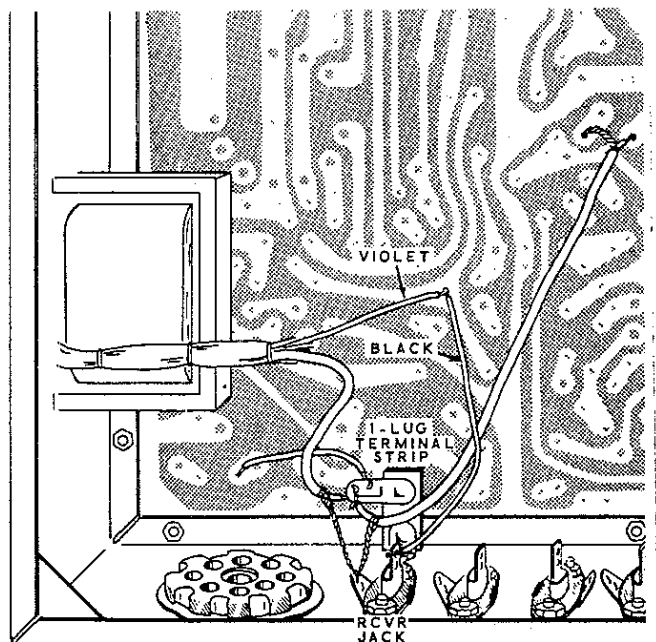

Figure 3A

- () Remove the inner leads of the two coaxial cables and the black wire from lug 1 of the RCVR jack. Connect these wires to lug 1 of the terminal strip (S-3).
- () Connect a 3-1/2" black wire from lug 1 of the RCVR jack (S-1) to the circuit board foil near terminal pin 7 (S-1).
- () Change the lettering of this jack from RCVR to ALC. A grease pencil or marker pencil works very well for this.
- () Load the exciter to full output. The meter of the Linear Amplifier may be used for this purpose, as it will function in both the REL PWR and SWR positions without the Linear Amplifier being turned ON.
- () Adjust the METER SENS control of the Linear Amplifier for a SET (full-scale) indication on the meter.

This completes the modification of your Transceiver.

SWR MEASUREMENTS *

- () Connect the Linear Amplifier to the exciter and the antenna. Do not turn on the Linear Amplifier, thus permitting the exciter to feed through the Linear Amplifier to the antenna.
- () Place the Linear Amplifier METER switch in the FWD position.

NOTE: SWR checks can also be made with the Linear Amplifier operating at full power (1000 watts); however, due to the nonlinear characteristics of crystal diodes in the SWR circuit, the most accurate SWR readings are obtained at low power (70 to 100 watt) levels using only the exciter. If the exciter alone will not give full scale relative power readings, the Linear Amplifier may be used, however, limit the drive from the exciter to no more than necessary.

OPERATION

SSB OPERATION

- () Connect all leads between the Linear Amplifier, the exciter, and the power supply.
- () Connect a dummy load or antenna to the RF OUTPUT socket on the Linear Amplifier.
- () Set the exciter to the desired frequency.
- () Set the Linear Amplifier BAND switch to the desired band.
- () Turn on the exciter only. Load the exciter in a normal manner at the desired frequency. NOTE: With the Linear Amplifier turned off, the exciter output is fed through the Linear Amplifier to the RF OUTPUT jack. The FWD and SWR functions of the Linear Amplifier meter can be used in loading the exciter.
- () Check the SWR of the antenna system as described previously. (see above) *
- () Reduce the drive level of the exciter to a minimum.
- () Turn on the Linear Amplifier and apply a small amount of RF from the exciter. Peak the TUNE control for maximum REL PWR on the Linear Amplifier meter.
- () Switch the exciter for SSB operation and set the microphone level to the desired level.

This procedure of tuning the Linear Amplifier should take only a few seconds, after you go through it a few times. The Linear Amplifier is now loaded for operation at maximum input power.



CW OPERATION

This Linear Amplifier, while designed for SSB use, can be used for CW operation with the Heathkit Model HP-24 AC Power Supply. The duty cycle must not exceed the normal telegraphy duty cycle of 33% maximum.

For CW operation, the Linear is tuned the same as for SSB operation, except that the exciter is set for CW operation. The exciter output should be increased to maximum output (approximately 100 watts) and keyed.

IN CASE OF DIFFICULTY

1. Recheck the wiring. Trace each lead in colored pencil on the Pictorial as it is checked. It is frequently helpful to have a friend check your work. Someone who is not familiar with the unit may notice something consistently overlooked by the constructor.
2. It is interesting to note that about 90% of the kits that are returned for repair, do not function properly due to poor connections and soldering. Therefore, many troubles can be eliminated by reheating all connections to make sure that they are soldered as described in the Proper Soldering Techniques section of this manual.
3. Check to be sure that all tubes are in their proper locations. Make sure that all tubes light up properly.
4. Check the values of the parts. Be sure that the proper part has been wired into the circuit, as shown in the pictorial diagrams and as called out in the wiring instructions.
5. Check for bits of solder, wire ends or other foreign matter which may be lodged in the wiring.
6. If, after careful checks, the trouble is still not located and a voltmeter is available, check voltage readings against those shown on the Schematic Diagram. NOTE: All voltage readings were taken with an 11 megohm input vacuum tube voltmeter. Voltages may vary as much as 10%.
7. A review of the Circuit Description will prove helpful in indicating where to look for trouble.



TROUBLESHOOTING CHART

SYMPTOM	POSSIBLE CAUSE
Tube filaments and pilot lamp do not light.	<ol style="list-style-type: none"> 1. Power plug or sockets incorrectly wired. 2. Open circuit breaker in power supply. 3. Tube filaments and pilot lamp wiring incorrect. NOTE: Tube filaments are connected in series. If one opens, neither will light.
Antenna relay will not close when exciter is keyed.	<ol style="list-style-type: none"> 1. No bias voltage (-120) to relay. 2. No ground between pin 12 of power socket and exciter in keyed position.
No forward or reflected power reading on Linear Amplifier meter.	<ol style="list-style-type: none"> 1. Wiring error on Meter switch. 2. Wiring error on SWR coaxial cable. 3. Shielded leads shorted. 4. Defective diodes D2 and/or D3.
Output will not peak on some or all bands.	<ol style="list-style-type: none"> 1. Band switch in wrong position. 2. 80-40-20 meter final coil incorrectly mounted and wired. 3. Tubular capacitors interchanged.
All power to Linear Amplifier turns off in mobile operation.	<ol style="list-style-type: none"> 1. Overdriving from exciter. 2. The microphone level setting on the exciter is too high. 3. Defective 40 ampere circuit breaker in power supply.
In mobile operation, antenna relay keeps dropping out on voice peaks.	<ol style="list-style-type: none"> 1. The microphone level setting on the exciter is too high. 2. No ALC voltage being applied back to the exciter. 3. Exciter ALC circuit not operating. 4. Corroded battery connections causing a high resistance connection.

SERVICE INFORMATION

SERVICE

If, after applying the information in this manual and your best efforts, you are still unable to obtain proper performance, it is suggested that you take advantage of the technical facilities which the Heath Company makes available to its customers.

The Technical Consultation Department is maintained for your benefit. This service is available to you at no charge. Its primary purpose is to provide assistance for those who encounter difficulty in the construction, operation or maintenance of HEATHKIT equipment. It is not intended, and is not equipped to function as a general source of technical information involving kit modifications nor anything other than the normal and specified performance of HEATHKIT equipment.

Although the Technical Consultants are familiar with all details of this kit, the effectiveness of their advice will depend entirely upon the amount and the accuracy of the information furnished by you. In a sense, **YOU MUST QUALIFY** for GOOD technical advice by helping the consultants to help you. Please use this outline:

1. Before writing, fully investigate each of the hints and suggestions listed in this manual under In Case Of Difficulty. Possibly it will not be necessary to write.
2. When writing, clearly describe the nature of the trouble and mention all associated equipment. Specifically report operating procedures, switch positions, connections to other units, and anything else that might help to isolate the cause of trouble.
3. Report fully on the results obtained when testing the unit initially and when following the suggestions under In Case Of Difficulty. Be as specific as possible and include voltage readings if test equipment is available.

4. Identify the kit Model Number and Series Number, and date of purchase, if available. Also mention the date of the kit assembly manual. (Date at bottom of Page 1.)
5. Print or type your name and address, preferably in two places on the letter.

With the preceding information, the consultant will know exactly what kit you have, what you would like it to do for you and the difficulty you wish to correct. The date of purchase tells him whether or not engineering changes have been made since it was shipped to you. He will know what you have done in an effort to locate the cause of trouble and, thereby, avoid repetitious suggestions. In short, he will devote full time to the problem at hand, and through his familiarity with the kit, plus your accurate report, he will be able to give you a complete and helpful answer. If replacement parts are required, they will be shipped to you, subject to the terms of the Warranty.

The Factory Service facilities are also available to you, in case you are not familiar enough with electronics to provide our consultants with sufficient information on which to base a diagnosis of your difficulty, or in the event that you prefer to have the difficulty corrected in this manner. You may return the completed equipment to the Heath Company for inspection and necessary repairs and adjustments. You will be charged a minimal service fee, plus the price of any additional parts or material required. However, if the completed kit is returned within the Warranty period, parts charges will be governed by the terms of the Warranty. State the date of purchase, if possible.

Local Service by Authorized HEATHKIT Service Centers is also available in some areas and often will be your fastest, most efficient method of obtaining service. HEATHKIT Service Centers will honor the regular 90 day HEATHKIT Parts Warranty on all kits, whether purchased through a dealer or directly from the Heath Company; however, it will be necessary that you verify the purchase date of your kit.



Under the conditions specified in the Warranty, replacement parts are supplied without charge; however, if the Service Center assists you in locating a defective part (or parts) in your kit, or installs a replacement part for you, you may be charged for this service.

HEATHKIT equipment purchased locally and returned to Heath Company for service must be accompanied by your copy of the dated sales receipt from your authorized HEATHKIT dealer in order to be eligible for parts replacement under the terms of the Warranty.

THIS SERVICE POLICY APPLIES ONLY TO COMPLETED EQUIPMENT CONSTRUCTED IN ACCORDANCE WITH THE INSTRUCTIONS AS STATED IN THE MANUAL. Equipment that has been modified in design will not be accepted for repair. If there is evidence of acid core solder or paste fluxes, the equipment will be returned NOT repaired.

For information regarding modification of HEATHKIT equipment for special applications, it is suggested that you refer to any one or more of the many publications that are available on all phases of electronics. They can be obtained at or through your local library, as well as at most electronic equipment stores. Although the Heath Company sincerely welcomes all comments and suggestions, it would be impossible to design, test, evaluate and assume responsibility for proposed circuit changes for special purposes. Therefore, such modifications must be made at the discretion of the kit builder, using information available from sources other than the Heath Company.

REPLACEMENTS

Material supplied with HEATHKIT products has been carefully selected to meet design requirements and ordinarily will fulfill its function without difficulty. Occasionally, improper operation can be traced to a faulty component. Should inspection reveal the necessity for replacement, write to the Heath Company and supply all of the following information.

A. Thoroughly identify the part in question by using the part number and description found in the manual Parts List.

- B. Identify the kit Model Number and Series Number.
- C. Mention date of purchase.
- D. Describe the nature of defect or reason for requesting replacement.

The Heath Company will promptly supply the necessary replacement. PLEASE DO NOT RETURN THE ORIGINAL COMPONENT UNTIL SPECIFICALLY REQUESTED TO DO SO. Do not dismantle the component in question as this will void the guarantee. This replacement policy does not cover the free replacement of parts that may have been broken or damaged through carelessness on the part of the kit builder.

SHIPPING INSTRUCTIONS

In the event that your instrument must be returned for service, these instructions should be carefully followed.

Wrap the equipment in heavy paper, exercising care to prevent damage. Place the wrapped equipment in a stout carton of such size that at least three inches of shredded paper, excelsior, or other resilient packing material can be placed between all sides of the wrapped equipment and the carton. Close and seal the carton with gummed paper tape, or alternately, tie securely with stout cord. Clearly print the address on the carton as follows:

To: HEATH COMPANY
Benton Harbor, Michigan 49023

ATTACH A LETTER TO THE OUTSIDE OF THE CARTON BEARING YOUR NAME, COMPLETE ADDRESS, DATE OF PURCHASE, AND A BRIEF DESCRIPTION OF THE DIFFICULTY ENCOUNTERED. Also, include your name and return address on the outside of the carton. Preferably affix one or more "Fragile" or "Handle With Care" labels to the carton, or otherwise so mark with a crayon of bright color. Ship by insured parcel post or prepaid express; note that a carrier cannot be held responsible for damage in transit if, in HIS OPINION, the article is inadequately packed for shipment.



WARRANTY

Heath Company warrants that all Heathkit parts shall be free of all defects in materials and workmanship under normal use and service, and in fulfillment of such warranty Heath Company will, for a period of three months from the date of shipment, replace any part upon verification that it is defective.

The foregoing warranty shall apply only to the original buyer, and is and shall be in lieu of all other warranties, whether express or implied and of all other obligations or liabilities on the part of Heath Company and in no event shall Heath Company be liable for any anticipated profits, consequential damages, loss of time or other losses incurred by the buyer in connection with the purchase, assembly or operation of Heathkits or components thereof. No replacement shall be made of parts damaged by the buyer in the course of handling or assembling Heathkit equipment.

The foregoing warranty is completely void if corrosive solder or fluxes have been used in wiring the equipment. Heath Company will not replace or repair any equipment in which corrosive solder or fluxes have been used.

This warranty applies only to Heath equipment sold and shipped within the continental United States including APO and FPO shipments. Warranty replacement for Heathkit equipment outside the United States is on an f.o.b. factory basis. Contact the Heathkit authorized distributor in your country or write: Heath Company, International Division, Benton Harbor, Michigan, U.S.A.

HEATH COMPANY

SPECIFICATIONS

Band Coverage.	80, 40, 20, 15, and 10 meters.
Maximum Power Input.	SSB: 1000 watts P.E.P.
Driving Power Required.	100 watts.
Duty Cycle.	SSB: 50% voice modulation.
Third Order Distortion.	-30 db or better at 1000 watts P.E.P.
Output Impedance.	50 to 75 Ω unbalanced, SWR not to exceed 2:1.
Input Impedance.	52 Ω unbalanced; broad-band pretuned input circuit requires no tuning.
Meter Functions.	0-6 relative power. 1:1 to 3:1 SWR.
Front Panel Controls.	Tune: 80, 40, 20, 15, and 10 meters. Band: 80, 40, 20, 15, and 10 meters. Relative Power Sensitivity control. Meter switch: FWD and SWR. Power switch: OFF, ON.
Tube Complement.	Two 572-B (or two T160-L) in parallel.
Power Requirements.	2000 V DC at 500 ma SSB peak, -120 V DC at 60 ma, an 12.6 V DC at 4 amperes.
Cabinet Size.	12-3/16" wide x 3-3/16" high x 10" deep.
Net Weight.	7 lbs.

All prices are subject to change without notice. The Heath Company reserves the right to discontinue instruments and to change specifications at

any time without incurring any obligation to incorporate new features in instruments previously sold.

2-39-A

CIRCUIT DESCRIPTION

Refer to the Schematic (fold-out from Page 43) while reading this Description. The Linear Amplifier is basically made up of three circuits: Input Circuit, Output Circuit, and the Antenna Change-Over and CutOff Bias Circuit. Each circuit is described individually.

INPUT CIRCUIT

Tubes V1 and V2 are connected in parallel in a cathode-driven (grounded grid), class B configuration. Driving power for each band is coupled through a broad-band network, consisting of a coil and associated capacitors, and through capacitor C13 to the cathodes of tubes V1 and V2. Coils L1 through L5 with their associated capacitors are used to make up these impedance-matching networks, which reduce distortion and increase efficiency.

The correct input network, as well as the correct output circuit coil tap, for each band is selected with the Band switch. (The coils in the input networks are factory aligned.)

To keep the capacitance of the filament supply from shunting the RF driving power to ground, the filament winding is isolated from the cathode circuit by a bifilar-wound filament choke. Also, this choke provides a cathode current path to ground.

OUTPUT CIRCUIT

High voltage is applied to the plates of tubes V1 and V2 through RF chokes RFC1 and RFC2 and parasitic chokes PC1 and PC2. Tuning capacitor C15 is connected on the input side of tapped final coils L6 and L7. C16 is switched in parallel with the Tuning capacitor on the 80 meter band.

Loading capacitor C18 is on the output side of final coils L6 and L7. Capacitor C17 is switched in parallel with the Loading capacitor on the 80 meter band. Output power is applied through antenna change-over relay RL1 and through the SWR (standing wave ratio) bridge circuit to the RF Output connector. The SWR bridge consists of coils L8, L9, and L10, capacitors C20 and C21, resistors R6 and R7, and crystal diodes D2 and D3. RF choke, RFC4, is connected from the output side of the final coils to ground to provide a direct DC to ground path in case capacitor C14 should short.

ANTENNA CHANGE-OVER, ALC, AND CUTOFF BIAS CIRCUITS

Antenna change-over relay RL1 is controlled by a VOX (voice operated transmitter) relay in the Exciter used with the Linear Amplifier. The relay in the Exciter is connected to the Antenna Relay lug (12) on the power plug of the Linear Amplifier. When transmitting, the VOX relay grounds the Antenna Relay; when receiving, the Antenna Relay is ungrounded.



While receiving, cut-off bias voltage from the power supply is applied through the coil of relay RL1, and through resistors R2, R3, and R4 and choke RFC3, to the grids of tubes V1 and V2. The Antenna Relay lug is ungrounded and no current will flow through the coil of relay RL1, which allows the relay to remain open. Thus it connects the RF Output jack (antenna) to the RF Input jack of the Linear Amplifier.

When transmitting, the Antenna Relay lug (12) is grounded by the VOX relay of the exciter. This allows current to flow through the coil of relay RL1 and actuate the relay. When actuated, relay RL1 connects the RF Output jack (antenna) to the output circuit of the Linear Amplifier. Grounding the Antenna Relay lug also grounds the grids of tubes V1 and V2 through RFC3, and resistors R3 and R4. This removes all but -2 volts from the grids of the tubes. This -2 volts which is developed across resistor R9 is operating bias, which limits resting plate current to approximately 90 milliamperes.

When operating with the Linear Amplifier turned Off, there is no bias voltage to operate relay RL1 and the RF Input jack remains connected to the antenna, through RF Output jack. This permits low power operation directly from the Exciter into the antenna without changing any cables. Because instant-heating-filament tubes are used in the Linear Amplifier, you can go to high power operation as soon as the Linear Amplifier is turned On.

During modulation the ALC control voltage is developed across a voltage divider that consists of capacitors C8 and C9. A sample of this volt-

age is rectified by diode D1. Diode D1 is reverse biased with approximately +6 V DC to form a threshold level. A negative DC control voltage is produced that is proportional to the modulation level. This control voltage is then applied back to the ALC input of the exciter.

Relative Power and Standing Wave Ratio are measured with a bridge circuit consisting of coils L8, L9, and L10, diodes D2 and D3, resistors R6 and R7, and capacitors C20 and C21. Relative Power Sensitivity control R5 sets the sensitivity of the meter. The FWD position is used when adjusting the Tune control for maximum output of the Linear Amplifier; this meter function is also used to establish a "set" meter level for making SWR measurements.

Because coil L9 of the bridge circuit is connected in series between the RF Input and RF Output jacks when the Linear Amplifier is turned off, the meter can be used to measure relative power and SWR when operating the Exciter alone. This method of checking SWR is recommended for accurately determining antenna performance.

In the bridge circuit, RF current is inductively and capacitively coupled from L9, to L8 and L10. The RF currents in L8 and L10 are rectified by diodes D2 and D3, and then filtered by capacitors C20 and C21.

For relative power measurements, the rectified RF voltage from L10 is applied to the meter. For SWR (reflected power) measurements, the rectified RF voltage from L8 is applied to the meter.

**SCHEMATIC OF THE HEATHKIT®
SSB LINEAR AMPLIFIER
MODEL HA-14**

NOTES:
ALL RESISTORS ARE 1/2 WATT UNLESS MARKED OTHERWISE.
ALL RESISTOR VALUES ARE IN OHMS UNLESS OTHERWISE MARKED.
ALL CAPACITOR VALUES ARE IN PFD UNLESS OTHERWISE MARKED.

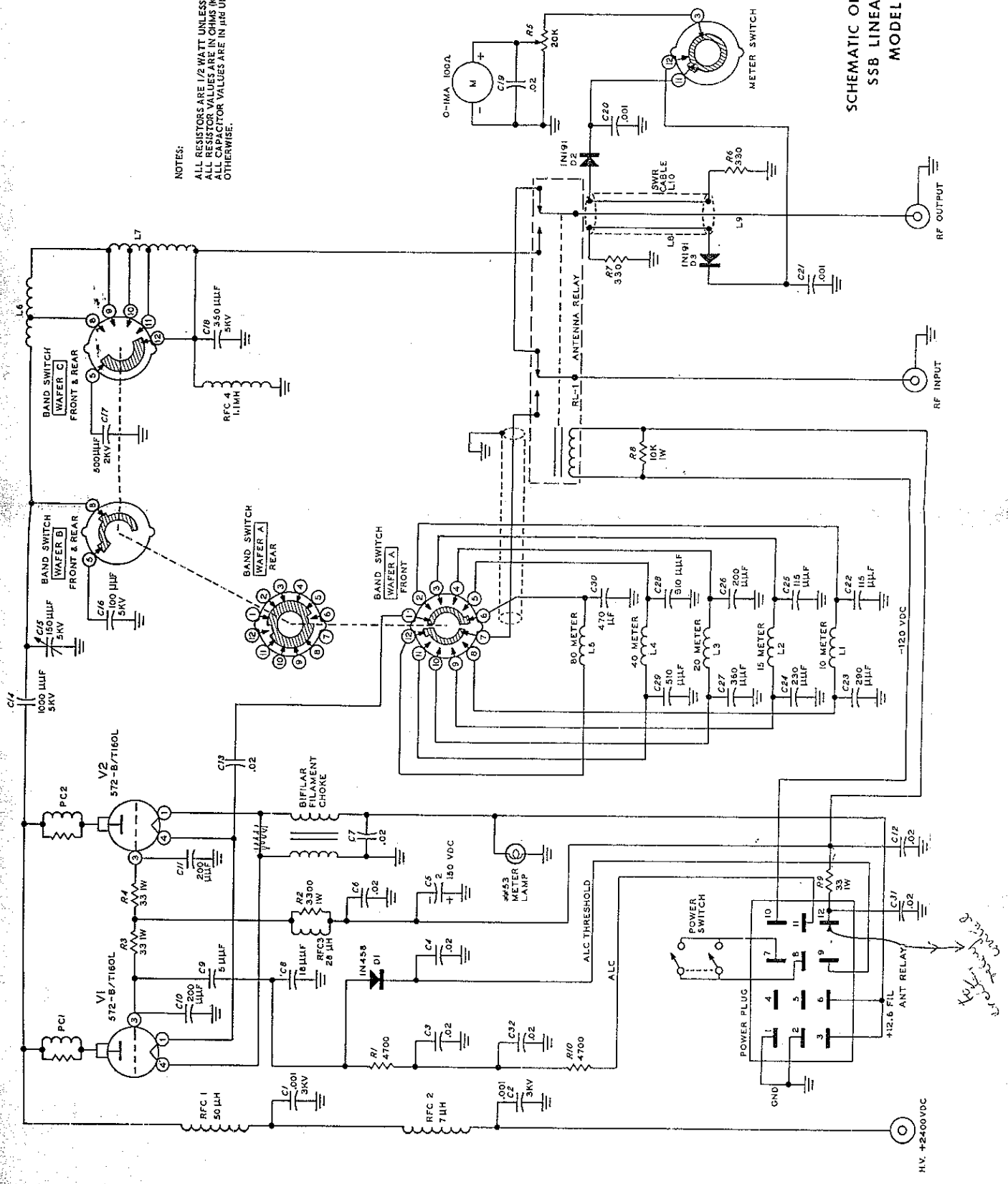

H.V. +2400VDC

Handwritten note: antenna cable