

PRICE \$2.00

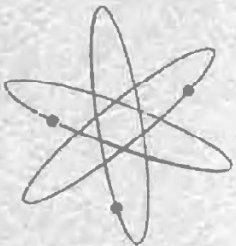

HEATHKIT®
ASSEMBLY MANUAL



**6-METER LINEAR
AMPLIFIER**

MODEL HA-20

Assembly
and
Operation
of the



6-METER
LINEAR
AMPLIFIER
MODEL HA-20

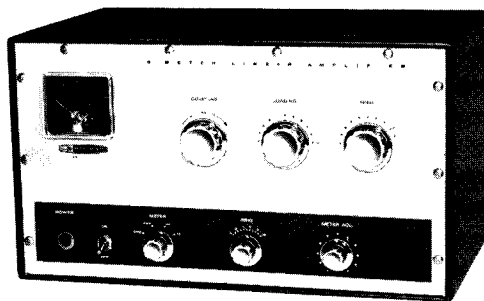

HEATH COMPANY,
BENTON HARBOR,
MICHIGAN



Copyright 1962
Heath Company

TABLE OF CONTENTS

Specifications	2
Introduction	3
Circuit Description	3
Construction Notes	5
Schematic	5*
Parts List	6
Proper Soldering Techniques	9
Step-By-Step Procedure	10
Step-By-Step Assembly	11
Parts Mounting-Chassis Plate	11
Preliminary Wiring-Chassis Bottom	14
Parts Mounting - Chassis Base	17
Parts Mounting-Grid Shield	18
Wiring-Grid Shield And Chassis Base	19
Wiring-Grid Compartment	20
Initial Wiring-Top Of Chassis	21
Assembly-Final Amplifier Housing	22
Initial Wiring - Final Amplifier	25
Final Amplifier Final Wiring And Parts Mounting	26
Top Of Chassis-Final Assembly And Wiring	28
Final Wiring-Bottom Chassis	30
Adjustments	33
Installation	37
In Case Of Difficulty	38
Troubleshooting Chart	38
Service Information	40
Service	40
Replacements	41
Shipping Instructions	41
Warranty	42

*Fold-out from page.

All prices are subject to change without notice. The Heath Company reserves the right to discontinue instruments and to change specifications at any time without incurring any obligation to incorporate new features in instruments previously sold.

SPECIFICATIONS

Driving Power Required,	2,5 to 10 watts P.E.P.
Power Input,	125 watts P.E.P. SSB. 75 watts DC AM.
Power Output To Antenna,	70 watts P.E.P. SSB.
Output Impedance,	50 to 75 Ω nonreactive.
Output Coupling,	Link.
Input Impedance,	Approximately 50 Ω .
Input Coupling,	Link (tuned grid).
Frequency Coverage,	49.8 to 54 megacycles.
Panel Metering,	0,6 ma grid current. 0-400 ma plate current. 0-1000 volts DC plate voltage. 0-1000 relative power.
Tube Complement,	2 - 6146 push-pull power amplifiers. 1 - OA2 voltage regulator.
Power Supply,	Filament: 6,3 volts at 4 amperes. Spare: 6,3 volts at 4 amperes. Bias: Negative 150 volts DC. Plate Supply: 600 volts DC. Self-contained blower.
Power Requirements,	95 watts standby. 200 watts maximum, at 117 volts AC, 50/60 cps.
Cabinet Size,	10-1/8" high x 16-5/8" wide x 10" deep.
Net Weight,	33 lbs.
Shipping Weight,	43 lbs.

INTRODUCTION

The Heathkit Model HA-20 Linear Amplifier was designed to amplify the 6-meter output from low-power exciters. The Heathkit HX-30 Exciter is ideal for this application.

The Amplifier RF compartment is completely enclosed by perforated metal shielding. This type of construction, in addition to the use of feedthrough capacitors for all power leads entering the RF compartments, increases amplifier stability and greatly decreases radiation that

could cause TVI. The Amplifier is forced-air cooled to promote longer tube life.

A single power switch operates the self-contained power supply. The power supply uses long-life silicon diode rectifiers in a conventional full-wave-doubler high voltage circuit. A single silicon diode rectifier is used in a half-wave circuit to develop the bias voltage. The output of the Amplifier is tuned with link-coupled output coils.

CIRCUIT DESCRIPTION

POWER SUPPLY

A conventional voltage-doubler circuit comprised of silicon diodes D3, D4, D5 and D6 delivers a DC voltage that is approximately twice the peak voltage developed in the high voltage secondary winding of power transformer T1. Filter capacitors C21 and C22 are each charged to the peak voltage of the transformer secondary on alternate half cycles, with the polarities connected such that the DC voltage developed across the capacitors add to each other. Additional filtering is accomplished by a RC combination, consisting of resistor R13 and capacitor C23. The DC plate voltage is taken from the top of C21 and has a no-load value of approximately 700 volts. Resistors R11 and R12 make up the bleeder network.

The power amplifier screen supply voltage is taken from the half-voltage point of the voltage doubler circuit. Additional filtering is provided by the RC combination of R13 and C23. The voltage is then dropped across resistors R19 and R20 and partially regulated by V3 at 210 volts DC. The screen supply voltage is tapped between R19 and R20 and fed through the decoupling network made up of C11 and R3 to the screens of tubes V1 and V2.

The DC bias voltage is obtained from a single silicon diode, D1, operating as a half-wave rectifier. Filtering of the bias voltage is accomplished by a RC network made up of resistors R8 and R9, and both sections of capacitor C20. Resistor R8 provides surge current protection to diode D1. The voltage developed is applied across resistors R14, R16, and R17.

With the CUTOFF BIAS jack grounded (as it is when the Amplifier is activated by an exciter) the normal 150 volts negative DC is dropped across R14 and allows a voltage of from 45 to 55 volts negative to be available at BIAS ADJUST control R16. This voltage is fed through meter shunt R15 and through the decoupling network made up of C2 and R1 to the grids of tubes V1 and V2. Thus, the operating bias may be set for proper operation.

When the CUTOFF BIAS jack is ungrounded (during exciter "standby") the bias appearing at the grids of V1 and V2 returns to 150 volts negative DC which reduces the current through V1 and V2 to zero. Resistor R10 serves as a bleeder path for the bias supply.

INPUT CIRCUIT

The input circuit has link coupling, using a 50Ω link comprised of L1 and C1, and a tuned grid tank coil consisting of coil L2 and capacitor C3. C3 is swamped by resistor R2. The value of R2 is correct for an exciter having an output of from 7 to 10 watts. If an exciter of approximately 2.5 watts is used, R2 should be replaced with a 2200Ω 2 watt resistor. An exciter having a power output between 2.5 and 7 watts will require a resistor value between 2200Ω and 1000Ω to give satisfactory results without overdriving the Amplifier.

FINAL AMPLIFIER

Two push-pull connected 6146 beam power pentodes, V1 and V2, are operated as class AB1 linear amplifiers. A fixed operating bias of approximately -50 volts is maintained on the grids of these tubes, limiting zero signal plate current to 50 milliamperes.

The RF driving voltage is developed across the tuned grid of L2 and C3. The grids of V1 and V2 are swamped by resistor R2 to provide maximum stability.

Neutralizing of V1 and V2 is accomplished by a conventional cross neutralization circuit, where the grid of one of the push-pull amplifiers is capacitively coupled to the plate of the other by means of a neutralizing stub.

The output of the Amplifiers is link coupled by final tank coil L4 to link coil L3, which is connected to the OUTPUT coax connector on the rear apron.

METER CIRCUIT

GRID - The voltage developed across resistor R15 provides a full-scale reading of 6/10 of a milliampere when the METER switch is in this position.

PWR - A small germanium diode, D1, is used to rectify a minute portion of the RF output voltage coupled by capacitor C14. This rectified voltage is indicated on the front panel meter; the amplifier adjustment is greatly simplified by this RF voltmeter which indicates proper tuning by a maximum reading.

MA - The voltage developed across resistor R18, by the flow of current in the plate circuit, is impressed across the meter, giving a full-scale indication of 400 milliamperes.

HV - Resistor R21, which is in series with the 50Ω meter movement, acts as a voltage divider and allows the meter to give a full-scale indication when 1000 volts are impressed across this series combination.

CONSTRUCTION NOTES

This manual is supplied to assist you in every way to complete your kit with the least possible chance for error. The sequence shown is the result of extensive research and experimentation. If followed carefully, the finished equipment will give highly stable and dependable operation. We suggest that you retain the manual in your files for future reference, both in the use of the equipment and for its maintenance.

UNPACK THE KIT CAREFULLY AND CHECK EACH PART AGAINST THE PARTS LIST. In so doing, you will become acquainted with the parts. Refer to the information on the inside covers of the manual to help you identify the components. If some shortage or parts damage is found in checking the Parts List, please read the Replacements section and supply the information called for therein. Include all inspection slips in your letter to us.

Resistors generally have a tolerance rating of 10% unless otherwise stated in the Parts List. Tolerances on capacitors are generally even greater. Limits of +100% and -20% are common for electrolytic capacitors.

We suggest that you do the following before work is started:

1. Lay out all parts so that they are readily available.
2. Provide yourself with good quality tools. Basic tool requirements consist of a screwdriver with a 1/4" blade; a small screwdriver with a 1/8" blade; long-nose pliers; wire cutters, preferably separate diagonal cutters; a penknife or a tool for stripping insulation from wires; a soldering iron (or gun) and rosin core solder. A set of nut drivers and a nut starter, while not necessary, will aid extensively in construction of the kit.

RF INPI



Most kit builders find it helpful to separate the various parts into convenient categories. Muffin tins or molded egg cartons make convenient trays for small parts. Resistors and capacitors may be placed with their lead ends inserted in the edge of a piece of corrugated cardboard until they are needed. Values can be written on the cardboard next to each component. The illustration shows one method that may be used.

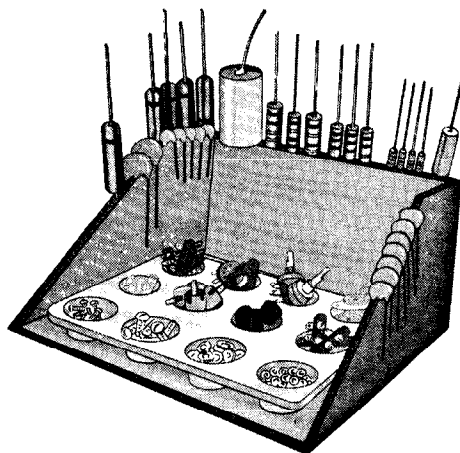

PARTS LIST

The numbers in parentheses in the Parts List are keyed to the numbers on the Parts Pictorial to aid in parts identification.

PART No.	PARTS Per Kit	DESCRIPTION	PART No.	PARTS Per Kit	DESCRIPTION
<u>Resistors</u>			<u>Controls-Switches</u>		
(1) 1-41	1	10 Ω 1/2 watt (brown-black-black)	(13) 10-118	1	2000 Ω control
1-3	1	100 Ω 1/2 watt (brown-black-brown)	10-19	1	5000 Ω control
1-45	1	220 Ω 1/2 watt (red-red-brown)	(14) 61-9	1	SPST toggle switch
1-19	2	6800 Ω 1/2 watt (blue-gray-red)	(15) 63-115	1	Rotary switch
1-20	1	10 K Ω 1/2 watt (brown-black-orange)	<u>Coils-Choke-Transformer-Coil Assemblies</u>		
1-24	1	33 K Ω 1/2 watt (orange-orange-orange)	40-345	1	6-meter link coupling coil
(2) 1B-28	2	15 Ω 2 watt (brown-green-black)	40-140	1	Final link coupling coil
1B-20	1	100 Ω 2 watt (brown-black-brown)	(16) 45-36	1	7 μ h RF choke
1B-15	1	1000 Ω 2 watt (brown-black-red)	54-109	1	Power transformer
1B-24	2	100 K Ω 2 watt (brown-black-yellow)	140-28	1	6-meter coil with 100 Ω 1/2 watt resistor
(3) 2-137	1	.125 Ω precision wire-wound	140-27	1	Final coil with 7 μ h RF choke
2B-10	1	1 megohm 2 watt precision	<u>Insulators-Grommets</u>		
(4) 3G-14	3	2000 Ω 7 watt wire-wound	(17) 71-4	1	Standoff insulator
<u>Capacitors</u>			75-25	1	Variable capacitor mounting board
(5) 21-33	1	3.3 μ mf disc ceramic	(18) 75-30	1	Line cord strain relief insulator
(6) 20-99	2	22 μ mf resin dipped	(19) 73-1	1	3/8" rubber grommet
20-97	1	50 μ mf resin dipped	(20) 73-6	2	Motor mounting grommet
21-14	5	.001 μ fd disc ceramic	<u>Diodes-Lamp-Tubes-Fuse</u>		
21-71	2	.001 μ fd 1400 V disc ceramic	(21) 56-4	1	Crystal diode (red-green-violet)
(7) 21-53	4	.001 μ fd feedthrough (brown-black-red)	(22) 57-27	5	Silicon diode
21-59	1	.001 μ fd 1000 V feedthrough (brown-black-red-black)	411-59	1	OA2 tube
(8) 25-7	1	20-20 μ fd 150 V tubular electrolytic	411-75	2	6146 tube
(9) 25-36	1	40 μ fd 450 V tubular electrolytic	412-10	1	Pilot lamp
25-34	2	125 μ fd 450 V twist-prong electrolytic	421-3	2	2 ampere fuse
(10) 26-39	1	3.2-11 μ mf variable "butterfly"	<u>Hardware</u>		
(11) 26-50	1	5.5-82.5 μ mf variable "butterfly"	(23) 250-8	45	#6 x 3/8" sheet metal screw
(12) 26-48	1	10.5 μ mf variable "butterfly"	(24) 250-49	14	3-48 x 1/4" screw
			(25) 250-136	2	3-48 x 1/2" screw
			(26) 250-56	36	6-32 x 1/4" screw
			(27) 250-89	5	6-32 x 3/8" screw
			(28) 250-33	2	6-32 x 1/8" slotted setscrew
			(29) 250-100	1	6-32 x 5/16" slotted setscrew
			(30) 250-105	5	8-32 x 1/8" allen setscrew
			(31) 250-93	11	8-32 x 1/4" allen setscrew
			(32) 250-22	1	8-32 x 7/16" slotted setscrew
			(33) 250-18	4	8-32 x 3/8" screw
			(34) 250-50	12	10-32 x 3/8" screw, phillips head

PART PARTS DESCRIPTION
No. Per Kit

PART PARTS DESCRIPTION
No. Per Kit

Hardware (cont'd)

(35)	250-152	1	10-24 x 3/4" screw
(36)	251-1	16	6-32 spade bolt
(37)	252-1	16	3-48 nut
(38)	252-3	52	6-32 nut
(39)	252-4	8	8-32 nut
(40)	252-30	1	10-24 nut
(41)	252-31	1	10-24 wing nut
(42)	252-7	12	Control nut
(43)	253-8	2	#10 flat washer
(44)	253-19	2	#10 large washer
(45)	253-11	2	E washer
(46)	253-36	1	Spring washer
(47)	253-10	7	Control washer
(48)	253-22	1	Spacer washer
(49)	254-7	17	#3 lockwasher
(50)	254-1	60	#6 lockwasher
(51)	254-2	8	#8 lockwasher
(52)	254-3	2	#10 lockwasher
(53)	254-4	12	Control lockwasher
(54)	259-6	3	Small #6 solder lug
(55)	259-1	1	Large #6 solder lug
(56)	259-10	2	Control solder lug

Terminal Strips

(63)	431-38	2	Miniature 3-lug
	431-2	1	Medium 2-lug
(64)	431-10	1	Medium 3-lug
(65)	431-3	1	Medium 3-lug
(66)	431-40	1	Medium 4-lug
(67)	431-28	1	Medium dual 2-lug
(68)	431-44	1	Large 4-lug
(69)	431-42	2	Large 5-lug

Shafts-Bushings-Collar-Couplings-Pulleys

	453-65	1	3-1/8" metal extension shaft
	453-60	1	3-3/4" insulated extension shaft
	453-115	1	4-11/32" metal drive shaft
(70)	453-63	1	6" final link coupling shaft
	453-77	1	7" insulated extension shaft
(71)	455-11	1	Split bushing
(72)	455-6	2	Round flange 1/4" bushing
(73)	455-13	3	Hex flange 1/4" bushing
(74)	455-10	4	3/8" bushing
(75)	455-15	2	Shaft collar
(76)	456-7	1	Metal shaft coupling
(77)	456-4	2	Insulated shaft coupling
(78)	100-M162	1	Shaft and pulley assembly
(79)	100-M165	1	Small dial pulley
(80)	100-M121	1	Large dial pulley
(81)	100-M302	2	Pulley and bracket assembly

Wire-Cable-Braid-Sleeving

89-4	1	Length line cord
340-3	1	Length heavy buss wire
344-1	1	Length small hookup wire
344-13	1	Length heavy hookup wire
344-15	1	Length stranded hookup wire
343-2	1	Length shielded cable
345-1	1	Length braid
346-1	1	Length sleeving

Sockets-Connector-Shield-Plugs

(57)	434-34	1	7-pin miniature tube socket
(58)	434-53	2	Octal tube socket
(59)	434-42	1	Phono socket
(60)	436-5	2	Coax connector
(61)	206-43	2	Coax connector shield
(62)	438-4	1	Phono plug
	438-11	1	Line plug (fused)

Metal Parts

	90-91	1	Cabinet
(82)	204-9	2	Angle bracket
(83)	266-18	1	180 degree rotational stop
(84)	266-19	1	90 degree rotational stop
(85)	204-M513	1	Capacitor mounting bracket
(86)	204-M514	1	Shaft support bracket

<u>PART No.</u>	<u>PARTS Per Kit</u>	<u>DESCRIPTION</u>	<u>PART No.</u>	<u>PARTS Per Kit</u>	<u>DESCRIPTION</u>
<u>Chassis Parts</u>			<u>Miscellaneous</u>		
NOTE: Refer to the exploded drawing for identification of the following parts.			(87) 212-M4	2	Anode strip
			(88) 258-1	2	Dial cord spring
			(89) 260-12	2	Anode cap
			(90) 261-6	4	Rubber feet
			266-21	1	Fan blade
			349-1	1	Length dial cord
206-M82	1	Final amplifier top shield	407-55	1	Meter
206-M81	1	Final amplifier rear shield	420-3	1	Fan motor
206-M199	1	Final amplifier housing	(91) 452-4	1	Roll pin
205-M386	1	Chassis plate	462-172	3	Small knob
100-M412F820	1	Chassis base	462-158	3	Large knob
203-M328F822	1	Front panel	(92) 481-1	1	Metal capacitor mounting wafer
205-M388F821	1	Control escutcheon panel	481-3	1	Insulated capacitor mounting wafer
206-M200	1	Grid compartment shield	490-6	1	Allen wrench
205-M387	1	Bottom plate	331-6	1	Solder
			595-590	1	Manual

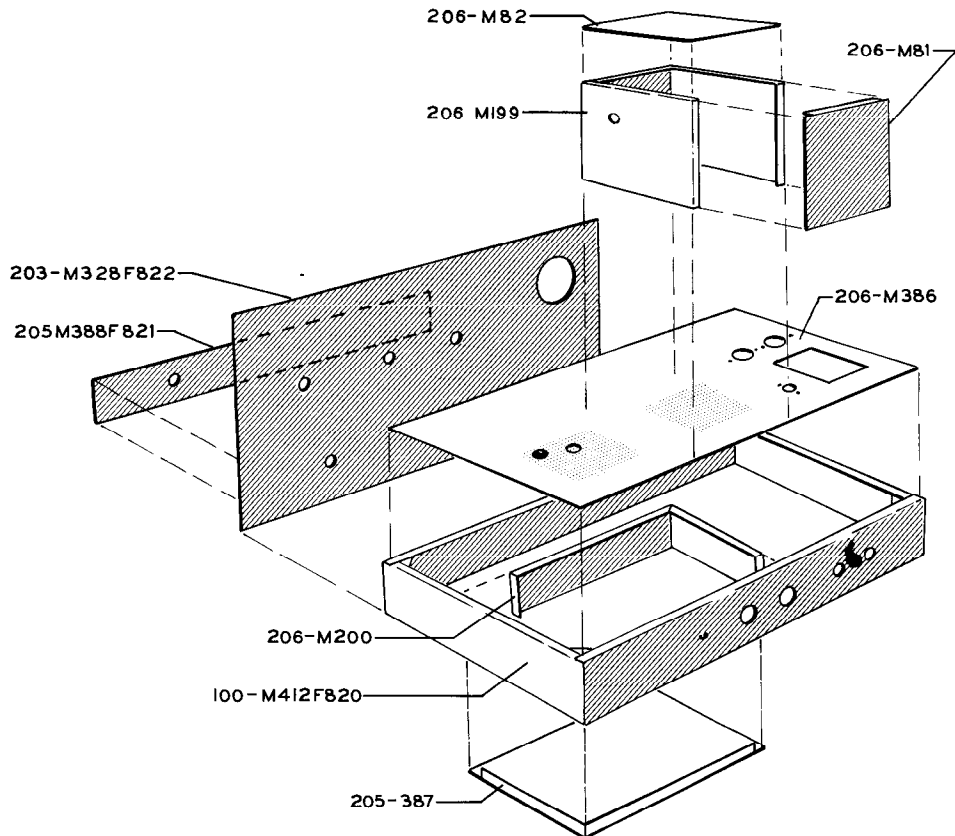

PROPER SOLDERING TECHNIQUES

Only a small percentage of customers find it necessary to return equipment for factory service. By far the largest portion of malfunctions in this equipment are due to poor or improper soldering.

If terminals are bright and clean and free of wax, frayed insulation and other foreign substances, no difficulty will be experienced in soldering. Correctly soldered connections are essential if the performance engineered into a kit is to be fully realized. If you are a beginner with no experience in soldering, a half hour's practice with some odd lengths of wire may be a worthwhile investment.

For most wiring, a 30 to 100 watt iron or its equivalent in a soldering gun is very satisfactory. A lower wattage iron than this may not heat the connection enough to flow the solder smoothly. Keep the iron tip clean by wiping it from time to time with a cloth.

CHASSIS WIRING AND SOLDERING

1. Unless otherwise indicated, all wire used is the type with colored insulation (hookup wire). In preparing a length of hookup wire, 1/4" of insulation should be removed from each end unless directed otherwise in the assembly step.
2. To avoid breaking internal connections when stripping insulation from the leads of transformers or similar components, care should be taken not to pull directly on the lead. Instead, hold the lead with pliers while it is being stripped.
3. Leads on resistors, capacitors, and similar components are generally much longer than need be to make the required connections. In these cases, the leads should be cut to proper length before the part is installed. In general, the leads should be just long enough to reach their terminating points.
4. Wherever there is a possibility of bare leads shorting to other parts or to the chassis, the leads should be covered with insulating sleeving. Where the use of sleeving is specifically intended, the phrase "use sleeving" is included in the associated assembly step. In any case where there is the possibility of an unintentional short circuit, sleeving should be used. Extra sleeving is provided for this purpose.
5. Crimp or bend the lead (or leads) around the terminal to form a good joint without relying on solder for physical strength. If the lead is too large to allow bending or if the step states that it is not to be crimped, position it so that a good solder connection can still be made.

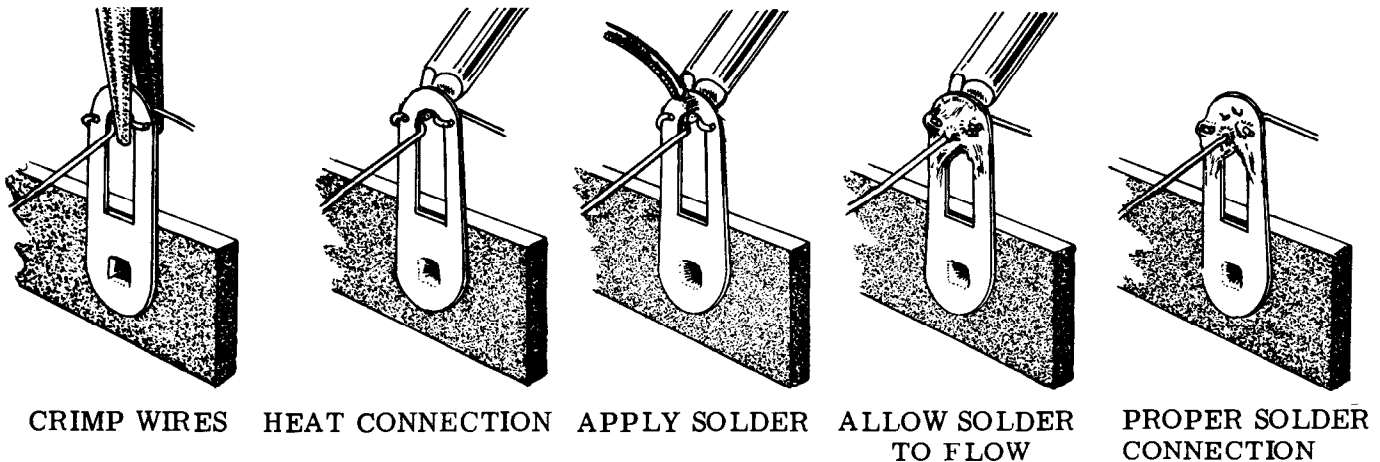

CRIMP WIRES

HEAT CONNECTION

APPLY SOLDER

ALLOW SOLDER
TO FLOWPROPER SOLDER
CONNECTION

6. Position the work, if possible, so that gravity will help to keep the solder where you want it.
7. Place a flat side of the soldering iron tip against the joint to be soldered until it is heated sufficiently to melt the solder.
8. Then place the solder against the terminal and it will immediately flow over the joint; use only enough solder to thoroughly wet the junction. It is usually not necessary to fill the entire hole in the terminal with solder.
9. Remove the solder and then the iron from the completed joint. Use care not to move the leads until the solder is solidified.

A poor or cold solder joint will usually look crystalline and have a grainy texture, or the solder will stand up in a blob and will not have adhered to the joint. Such joints should be reheated until the solder flows smoothly. In some cases, it may be necessary to add a little more solder to achieve a smooth, bright appearance.

ROSIN CORE SOLDER HAS BEEN SUPPLIED WITH THIS KIT. THIS TYPE OF SOLDER MUST BE USED FOR ALL SOLDERING IN THIS KIT. ALL GUARANTEES ARE VOIDED AND WE WILL NOT REPAIR OR SERVICE EQUIPMENT IN WHICH ACID CORE SOLDER OR PASTE FLUXES HAVE BEEN USED. IF ADDITIONAL SOLDER IS NEEDED, BE SURE TO PURCHASE ROSIN CORE (60:40 or 50:50 TIN-LEAD CONTENT) RADIO TYPE SOLDER.

STEP-BY-STEP PROCEDURE

The following instructions are presented in a logical step-by-step sequence to enable you to complete your kit with the least possible confusion. Be sure to read each step all the way through before beginning the specified operation. Also read several steps ahead of the actual step being performed. This will familiarize you with the relationship of the subsequent operations. When the step is completed, check it off in the space provided. This is particularly important as it may prevent errors or omissions, especially if your work is interrupted. Some kit builders have also found it helpful to mark each wire and part in colored pencil on the Pictorial as it is added.

ILLUSTRATIONS

The fold-out diagrams in this manual may be removed and attached to the wall above your working area; but because they are an integral part of the instructions, they should be returned to the manual after the kit is completed.

In general, the illustrations in this manual correspond to the actual configuration of the kit; however, in some instances the illustra-

tions may be slightly distorted to facilitate clearly showing all of the parts.

SOLDERING INFORMATION

The abbreviation "NS" indicates that a connection should not be soldered yet as other wires will be added. When the last wire is installed, the terminal should be soldered and the abbreviation "S" is used to indicate this. Note that a number will appear after each solder instruction. This number indicates the number of leads that are supposed to be connected to the terminal in point before it is soldered. For example, if the instruction reads, "Connect a wire to lug 1 (S-2)," it will be understood that there will be two wires connected to the terminal at the time it is soldered. (In cases where a wire passes through a terminal or lug and then connects to another point, it will count as two wires, one entering and one leaving the terminal.)

The steps directing the installation of resistors include color codes to help identify the parts. Also, if a part is identified by a letter-number designation (R1, C1, etc.) on the Schematic, its designation will appear at the beginning of the assembly step which directs its installation.

STEP-BY-STEP ASSEMBLY

PARTS MOUNTING-CHASSIS PLATE

Lockwashers will be used with all screws and nuts when mounting parts, unless stated otherwise in the assembly step. Consequently, the following steps will call out only the size and type of hardware to be used. For example, "Use 6-32 x 1/4" hardware" means to use a 6-32 x 1/4" screw, a #6 lockwasher (sometimes two), and a 6-32 nut.

NOTE: For parts identification, refer to the drawings in the Parts List.

Refer to Pictorial 1 for the following steps.

- () Locate the chassis plate (#205-M386) and position as shown.
- () Refer to Detail 1A and mount a large 5-lug terminal strip at location A. Use 6-32 x 1/4" hardware.

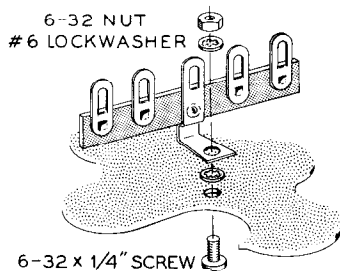

Detail 1A

- () Mount a large 5-lug terminal strip at location B. Use 6-32 x 1/4" hardware.
- () Mount a medium 4-lug terminal strip at location C. Use 6-32 x 1/4" hardware.
- () Install a 3/8" rubber grommet at location D.

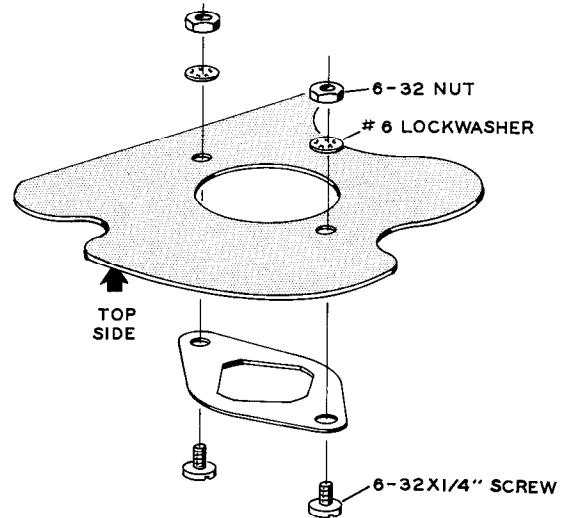

Detail 1B

- () Refer to Detail 1B and mount the metal capacitor mounting wafer on top of the chassis plate at location F. Use 6-32 x 1/4" hardware.
- () Refer to Detail 1C and mount the insulated capacitor mounting wafer on top of the chassis plate at location G, with a medium dual 2-lug terminal strip at location J on the bottom of the chassis plate. Use 6-32 x 1/4" and 6-32 x 3/8" hardware.

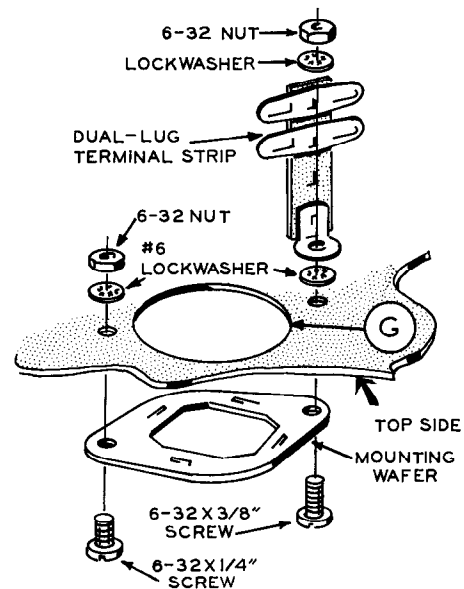

Detail 1C

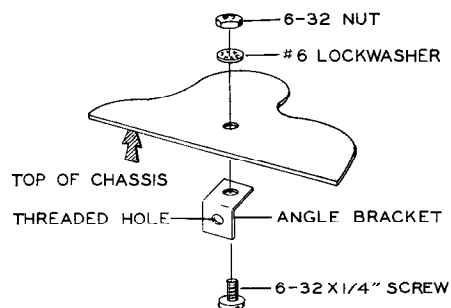

Detail 1H

- () Refer to Detail 1H and mount small angle brackets at locations BD and BE on top of the chassis plate. Use 6-32 x 1/4" hardware. Do not use the threaded holes in the brackets.
- () Install the motor mounting grommets at locations Q and S.
- () Refer to Detail 1J and mount the motor at location R. Use 10-32 x 3/8" phillips head screws and #10 flat washers. Do not over-tighten.
- () Start a 6-32 x 5/16" slotted setscrew in the bushing of the fan blade, then mount the blade on the motor shaft so the blades clear the motor mounting screws by 1/8". Tighten securely.

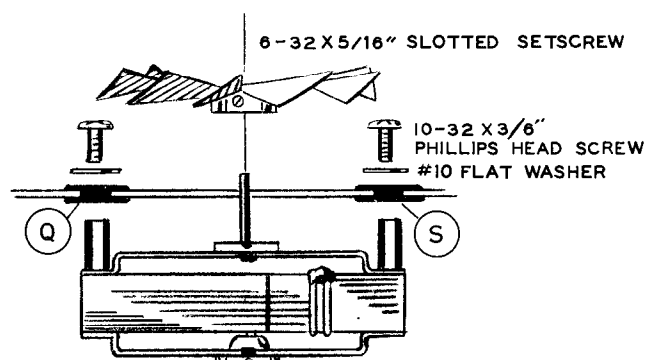

Detail 1J

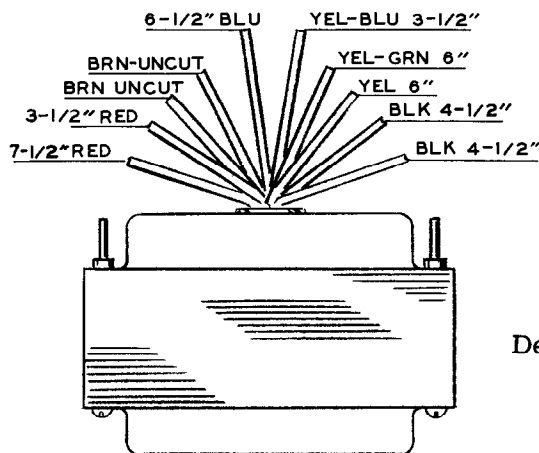

Detail 1K

- () Refer to Detail 1K and cut the power transformer (#54-109) leads to the following lengths. The leads should be measured from where they exit from the transformer. Strip 1/4" insulation from the end of each lead and tin. "Tin" means to melt a small amount of solder on the exposed lead end.
- () Yellow-blue 3-1/2"
- () Black 4-1/2"
- () Black 4-1/2"
- () Yellow-green 6"
- () Yellow 6"
- () Red 3-1/2"
- () Blue 6-1/2"
- () Red 7-1/2"

The two brown leads already are cut to the correct length.

- () T1. Mount the power transformer at location T1. Use #8 lockwashers and 8-32 nuts.
- () Place the chassis plate inside the chassis base for support while wiring.

PRELIMINARY WIRING-CHASSIS BOTTOM

NOTE: The lug numbering of the terminal strips in this kit is determined by viewing the terminal strip with the mounting foot facing you. The first lug on the left end of the strip is lug 1. This is true for the miniature, regular, and high voltage strips.

Refer to Pictorial 2 (fold-out from Page 17) for the following steps.

Connect the leads of transformer T1 as follows:

- () Twist the two black leads together, then connect one lead to lug 3 (NS) and the other to lug 4 (NS) of terminal strip K.
- () Twist the two brown leads together, then connect one lead to lug 2 of terminal strip B (NS), and the other lead to lug 4 of terminal strip C (NS).
- () Twist the two red leads together for a length of about 3", then connect the long lead to lug 4 of terminal strip B (NS).

The remaining transformer leads will be connected later.

NOTE: In the following steps where wire is called for, the small size hookup wire will be used unless stated otherwise.

- () Connect a 5" length of wire from lug 5 of terminal strip A (NS) to lug 1 of terminal strip B (NS).
- () C20. Connect one positive (+) lead of the 20-20 μ fd tubular electrolytic capacitor to lug 4 (NS) and the other (+) lead to lug 3 (NS) of terminal strip A. Connect the negative (-) lead to lug 2 of terminal strip B (NS). Position the capacitor as shown.
- () R8. Connect a 10 Ω (brown-black-black) 1/2 watt resistor between lugs 5 (S-2) and 4 (NS) of terminal strip A.
- () R9. Connect a 220 Ω (red-red-brown) 1/2 watt resistor between lugs 4 (S-3) and 3 (S-2) of terminal strip A.
- () C23. Connect the positive (+) lead of a 40 μ fd tubular electrolytic capacitor to lug 1 of terminal strip A (NS), and the other lead to lug 3 of terminal strip B (NS).

- () C18. Connect a .001 μ fd 1400 V disc ceramic capacitor between lugs 2 (NS) and 3 (NS) of terminal strip K.
- () C17. Connect a .001 μ fd 1400 V disc ceramic capacitor between lugs 2 (S-2) and 1 (NS) of terminal strip K.
- () Cut two 11" lengths of stranded wire, then strip and tin the ends. Twist the wires together and, at one end, connect either wire to lug 1 (NS) and the other to lug 4 (NS) of terminal strip K. Position the wires as shown and leave the other end free to be connected later.
- () In a like manner, cut two 15" lengths of stranded wire, strip and tin the ends. Twist the wires together. At one end, connect either wire to lug 4 (NS) and the other to lug 3 (NS) of terminal strip K. Pass the free end down through grommet D and leave the end free.
- () Connect one end of a 14" length of wire to lug 2 of terminal strip B (S-3). Position the wire as shown and leave the other end free.

NOTE: Protect diodes from heat damage by gripping the diode lead with long-nose pliers between the body of the diode and the solder connection.

NOTE: WHEN INSTALLING SILICON DIODES, THE CATHODE END SHOULD BE PLACED AS DIRECTED. THE CATHODE END IS MARKED WITH EITHER COLOR END, COLOR DOT, OR COLOR BAND. IN THE ILLUSTRATION, THE SYMBOL K INDICATES THE CATHODE END.

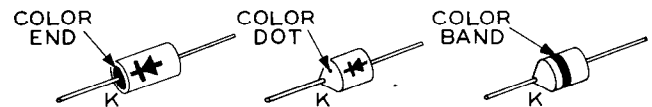

- () D2. Connect the lead from the marked end of a silicon diode to lug 1 of terminal strip B (S-2) and the other lead to lug 4 of terminal strip C (S-2).
- () D4. Connect the lead from the marked end of a silicon diode to lug 2 of terminal strip C (NS) and the other lead to lug 3 of terminal strip B (S-2).
- () D3. Connect the lead from the marked end of a silicon diode to lug 4 of terminal strip B (NS) and the other lead to lug 2 of terminal strip C (S-2).

- () D5. Connect the lead from the marked end of a silicon diode to lug 1 of terminal strip C (NS) and the other lead to lug 4 of terminal strip B (S-3).
- () D6. Connect the lead from the marked end of a silicon diode to lug 5 of terminal strip B (NS) and the other lead to lug 1 of terminal strip C (S-2).



Detail 2A

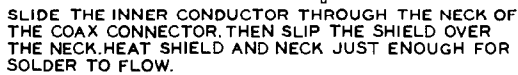
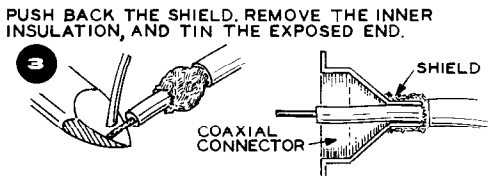
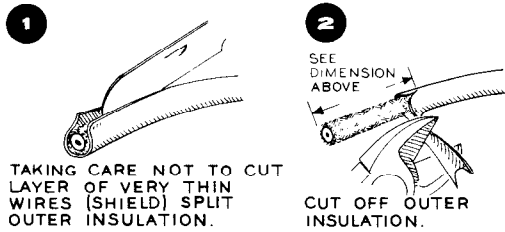

Detail 2B

- () Refer to Detail 2A and prepare a 7" length of shielded cable. Tin the exposed ends of the inner conductor.
- () Refer to Detail 2B and pass the longest inner conductor through coax connector shield L, with the braid outside of the neck of the connector shield. Solder the braid to the connector shield. Leave the other end of the cable free. Hold the inner conductor with a pair of long-nose pliers when soldering, to act as a heat sink to prevent melting the insulation.

- () If necessary bend ground lugs A, B, C, and D of sockets V1 and V2 down slightly, as shown.

NOTE: In the following steps where heavy buss wire is used, place the wire in the lower hole of the socket lugs, or if supplied with the socket type which has one elongated hole in each lug, the buss wire should be placed as low as possible in this hole and soldered only enough to hold it in place. Wires and component leads may be placed in upper holes (or in the second case, in the space allowed at the top of the socket lug).

Use heavy buss wire in the following steps for the wiring of tube socket V2.

- () Pass one end of the wire through lug 2 (NS) to ground lug A (S-1). Connect the other end of the wire to lug 1 (S-1). Now solder lug 2 (S-2).
- () Connect a wire from lug 4 (S-1) to ground lug B (NS).
- () Connect a wire from lug 6 (S-1) to ground lug C (S-1).
- () Connect a wire from lug 8 (S-1) to ground lug D (S-1).

Use heavy buss wire in the following steps for the wiring of tube socket V1.

- () Connect a wire from lug 1 (S-1) to ground lug A (S-1).
- () Connect a wire from lug 4 (S-1) to ground lug B (NS).
- () Pass a wire through lug 6 (NS) to ground lug C (S-1). Connect the other end of the wire to lug 7 (NS). Now solder lug 6 (S-2).
- () Connect a wire from lug 8 (S-1) to ground lug D (S-1).

- () Refer to Detail 2C and form two neutralizing stubs by laying the heavy buss wire on the illustration and bending to shape.
- () Place sleeving over each of the neutralizing stubs as shown.

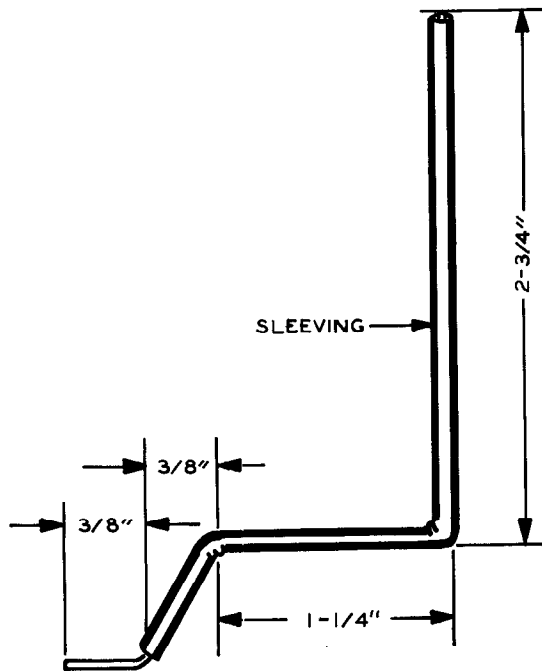

Detail 2C

- () Pass the long straight end of one of the neutralizing stubs through the chassis plate hole next to tube socket V2. Place the bare end in the lower hole of lug 5 of tube socket V2 (S-1).
- () In the same manner, position the other neutralizing stub in the hole next to tube socket V1 and place the bare end in the lower hole of lug 5 of tube socket V1 (S-1).

This completes the use of heavy buss wire for the time being.

- () Connect a 6-1/2" wire from lug 3 of tube socket V2 (NS) to lug 3 of tube socket V1 (NS).

- () Strip and tin both ends of a 4-1/2" length of stranded wire. Connect it from the bottom hole in lug 2 of tube socket V1 (NS) to the bottom hole in lug 7 of tube socket V2 (NS).
- () Strip and tin both ends of a 4" length of stranded wire. Connect one end in the top hole of lug 7 of tube socket V2 (NS). Leave the other end free.
- () C9. Connect a .001 μ fd disc ceramic capacitor between lugs 2 (S-1) and 7 (S-3) of tube socket V2.
- () C10. Connect a .001 μ fd disc ceramic capacitor between lug 3 (NS) and through ground lug B (S-2) of tube socket V2.
- () C7. Connect a .001 μ fd disc ceramic capacitor between lugs 2 (S-2) and 7 (S-2) of tube socket V1.
- () C8. Connect a .001 μ fd disc ceramic capacitor between lug 3 (S-2) and around ground lug B (S-2) of tube socket V1.

NOTE: If the exciter to be used with the Amplifier has an output of 7 to 10 watts, the 1000 Ω 2 watt resistor supplied for R2 is the proper value. However, if an exciter of approximately 2.5 watts output is used, a 2200 Ω 2 watt resistor should be substituted for R2. For an exciter wattage output other than listed above, a different value resistor for R2 will be required. A resistor value should be selected to give satisfactory output without overdriving the output tubes.

- () R2. Connect a 1000 Ω 2 watt resistor from the top hole in lug 5 of tube socket V1 (S-1) to the top hole in lug 5 of tube socket V2 (S-2).

Set the chassis plate aside temporarily.

PARTS MOUNTING-CHASSIS BASE

Refer to Pictorial 3 (fold-out from Page 18) for the following steps.

- () Refer to Detail 3A and temporarily mount the SPST toggle switch (#61-9) at location AB on the chassis base (#100-M412F820). Be sure the notch on the switch fits over the tab on the chassis base. Use the hardware supplied on the switch. Position the rear nut on the switch so it is 1/8" from the switch frame.

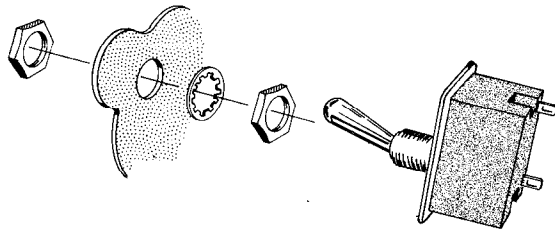

Detail 3A

- () Refer to Detail 3B and temporarily mount rotary switch (#63-115) at location AC. Use a control solder lug and control nut. Rebend and position the control solder lug with the switch lugs as shown.

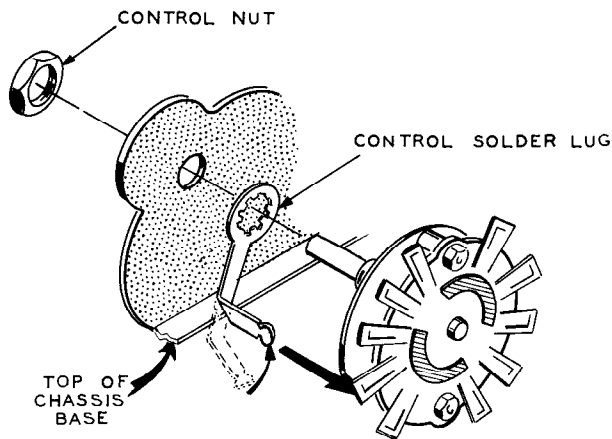

Detail 3B

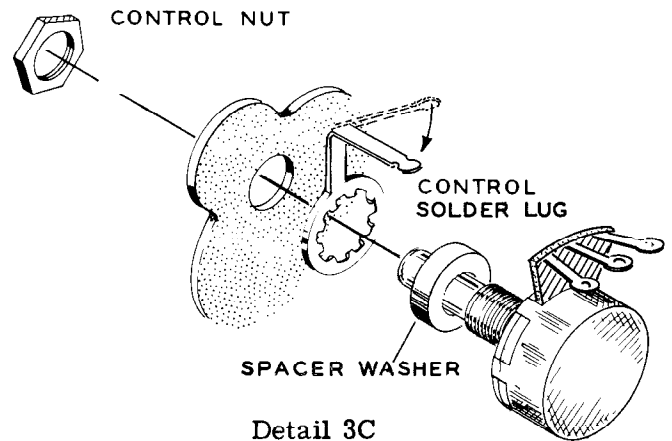

Detail 3C

- () R7. Refer to Detail 3C and temporarily mount the 2000 Ω (#10-118) control at location AE. Use a spacer washer, control solder lug and control nut. Rebend and position the control solder lug with the control lugs as shown.
- () R16. Mount the 5000 Ω (#10-19) control at location AG. Use a control lockwasher and nut. Position the control lugs as shown.
- () Refer to Detail 3D and mount a phono socket at location AK, with a 2-lug terminal strip at AH and a 3-lug terminal strip at AL. Use 6-32 x 3/8" hardware. Position the phono socket and terminal strip lugs as shown.

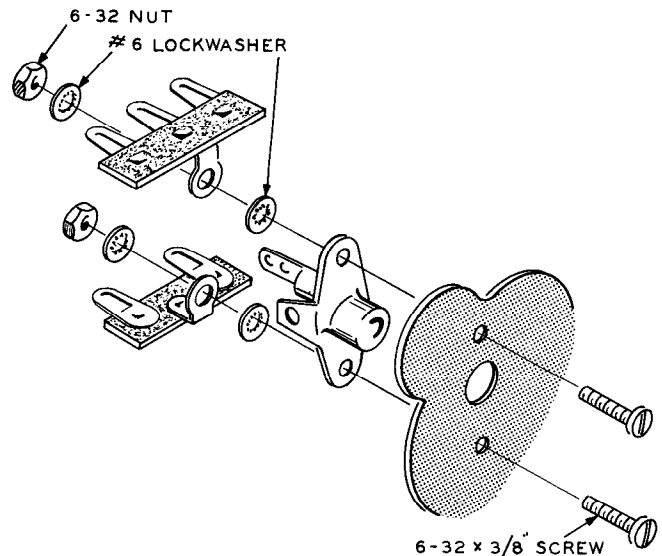

Detail 3D

- () Refer to Detail 3E and mount a coax connector at location AP with a miniature 2-lug terminal strip at location AN. Use 3-48 x 1/4" hardware. The miniature 2-lug terminal strip is obtained by cutting one lug from a 3-lug miniature terminal strip.

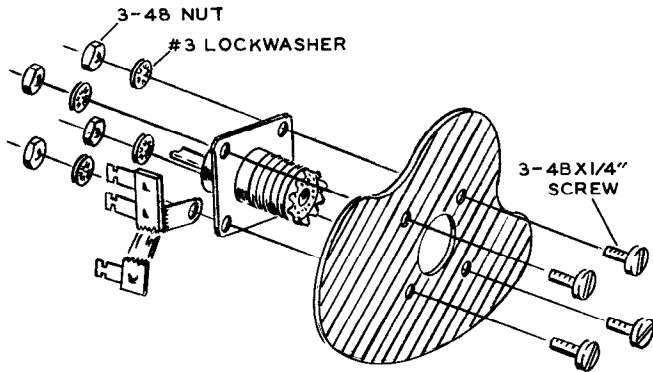

Detail 3E

- () Refer to Detail 3F and install the ground screw in the chassis hole next to coax connector AN. Use a 10-24 x 3/4" screw, two #10 lockwashers, 10-32 nut and tighten. Then place two #10 flat washers and a #10 wing nut on the screw.

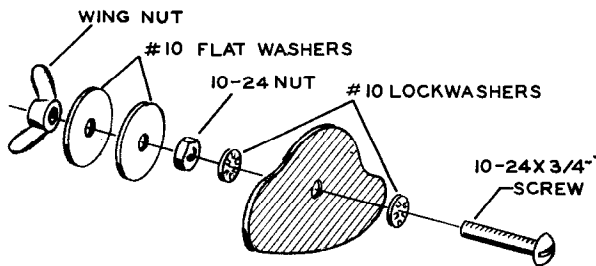

Detail 3F

Set the chassis base aside temporarily.

PARTS MOUNTING - GRID SHIELD

Refer to Pictorial 4 for the following steps.

- () Mount six 6-32 spade bolts on the grid compartment shield (#206-M200). Use 6-32 x 1/4" hardware. Be sure the offset of each spade bolt is positioned as shown.
- () Mount a medium 3-lug terminal strip at location AQ. Use 6-32 x 1/4" hardware.
- () C11. Mount a .001 μ fd feedthrough capacitor (brown-black-red) at location AT. Use the nut supplied.
- () C6. In a like manner, mount a .001 μ fd feedthrough capacitor (brown-black-red) at location AS.
- () C2. Mount a .001 μ fd feedthrough capacitor (brown-black-red) at location AR.¹

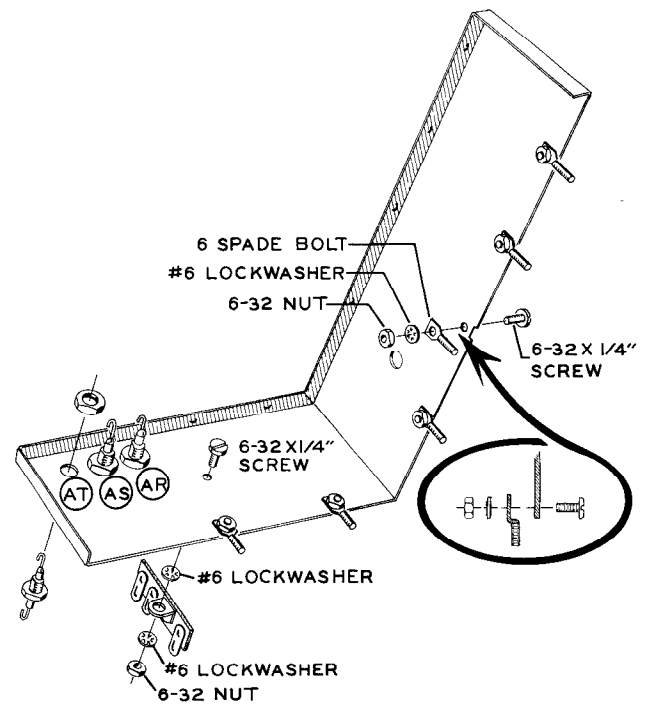

Pictorial 4

Refer to Pictorial 5 for the following steps.

- () Mount the grid compartment shield to the chassis plate. Use #6 lockwashers and 6-32 nuts on the spade bolts. Be careful not to pinch any of the wires under the grid compartment. Bend the neutralizing stubs down slightly so they will not get bent out of shape when the chassis is turned over.
- () Position the chassis plate on the chassis base. Be sure no wires are pinched between the two pieces. Secure the chassis plate to the chassis base with fifteen #6 x 3/8" sheet metal screws.

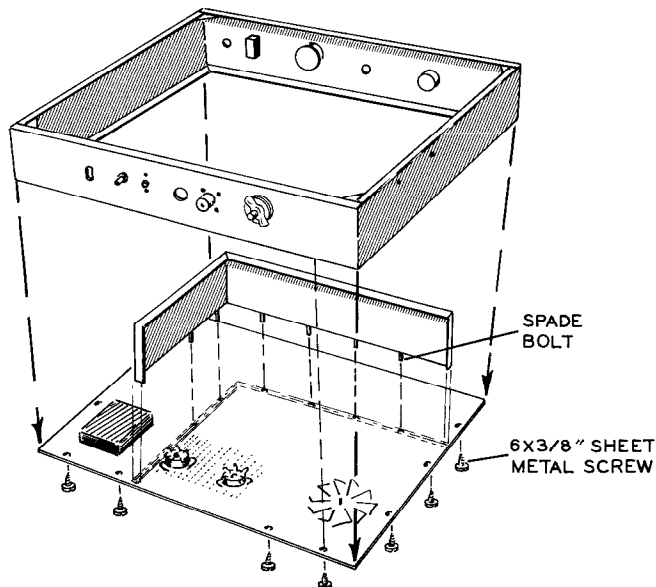

Pictorial 5

WIRING-GRID SHIELD AND CHASSIS BASE

Refer to Pictorial 6 (fold-out from Page 29) for the following steps.

- () Connect the free end of the wire coming from lug 2 of terminal strip B, to lug 3 of terminal strip AL (NS).

Connect the free lead ends of transformer T1 as follows:

- () Connect the blue lead to feedthrough capacitor AS (S-1).

- () Twist the yellow and the yellow-green leads together. Connect the yellow lead to lug 2 (S-1) and the yellow-green lead to lug 1 (S-1) of terminal strip AH.

- () Connect either wire of the twisted pair of stranded wires near terminal strip B to lug 1 (S-1) and the other to lug 2 (S-1) of switch AB. These are spare filament leads.

- () Connect a 1-1/2" wire from lug 9 and the ground lug (S-2) to lug 11 (S-1) of switch AC.

Use heavy hookup wire for the following steps and position the wires as shown.

- () Strip one end only of an 11" length of wire, and connect this end to lug 8 of switch AC (S-1). Pass the other through grommet D for connection later.

- () Strip both ends of an 11" wire and connect one end to lug 2 of switch AC (S-1). Pass the free end through grommet D for connection later.

- () Strip both ends of a 10-1/2" wire. Connect one end to lug 3 of terminal strip AQ (NS). Pass the free end through grommet D for connection later.

- () Connect a 4-1/2" wire from lug 4 of switch AC (S-1) to lug 2 of terminal strip J (NS).

- () Connect a 5-3/4" wire from lug 3 of switch AC (S-1) to lug 2 of terminal strip AQ (NS).

- () Connect a 6-1/2" wire from lug 10 of switch AC (S-1) to lug 3 of terminal strip AQ (NS).

- () Connect one end of a 2" wire to lug 1 of terminal strip J (S-1). Leave the other end free for connection later.

- () Connect one end of a 2" wire to lug 5 of terminal strip B (NS). Leave the other end free.

This completes the use of heavy hookup wire for the time being.

- () Connect a 6-1/2" wire from lug 1 of terminal strip A (NS) to lug 3 of terminal strip J (S-1).

- () Connect a 8-1/2" wire from lug 5 of switch AC (S-1) to lug 2 of control AE (S-1).
- () Connect a 9" wire from lug 12 of switch AC (S-1) to feedthrough capacitor AT (NS).
- () Connect a 9-1/2" wire from lug 6 of switch AC (S-1) to lug 1 of terminal strip AL (NS).
- () Connect a 2-1/2" wire from lug 2 of control AG (S-1) to lug 1 of terminal strip AL (NS).
- () Connect a 3" wire from lug 1 of terminal strip AQ (NS) to feedthrough capacitor AR (NS).
- () Connect one end of a 13" wire to lug 3 of control AE (S-1). Position the wire as shown through grommet D for connection later.
- () Bend the control solder lug against lug 1 of control AE and solder (S-1).
- () R19. Connect a 2000 Ω 7 watt wire-wound resistor from lug 4 of terminal strip J (S-1) to lug 1 of terminal strip AQ (NS).
- () R20. Connect a 2000 Ω 7 watt wire-wound resistor from lug 1 of terminal strip AQ (S-3) to lug 1 of tube socket V3 (S-1).
- () Bend lug 7 of tube socket V3 against solder lug M and solder (S-1).
- () R18. Connect the .125 Ω precision wire-wound resistor from lug 2 of terminal strip J (NS) to lug 3 of terminal strip AQ (S-3).
- () R21. Connect the 1 megohm precision resistor from lug 2 of terminal strip J (S-3) to lug 2 of terminal strip AQ (S-2).
- () R15. Connect a 100 Ω (brown-black-brown) 1/2 watt resistor from feedthrough capacitor AT (S-2) to lug 1 of terminal strip AL (S-3).
- () R17. Connect a 6800 Ω (blue-gray-red) 1/2 watt resistor from lug 1 of socket AK (S-1) to lug 3 of control AG (S-1).
- () R10. Connect a 33 K Ω (orange-orange-orange) 1/2 watt resistor between lugs 3 (NS) and 2 (S-1) of terminal strip AL.

- () R14. Connect a 10 K Ω (brown-black-orange) 1/2 watt resistor from lug 1 of control AG (S-1) to lug 3 of terminal strip AL (S-3).

WIRING-GRID COMPARTMENT

Refer to Pictorial 7 for the following steps.

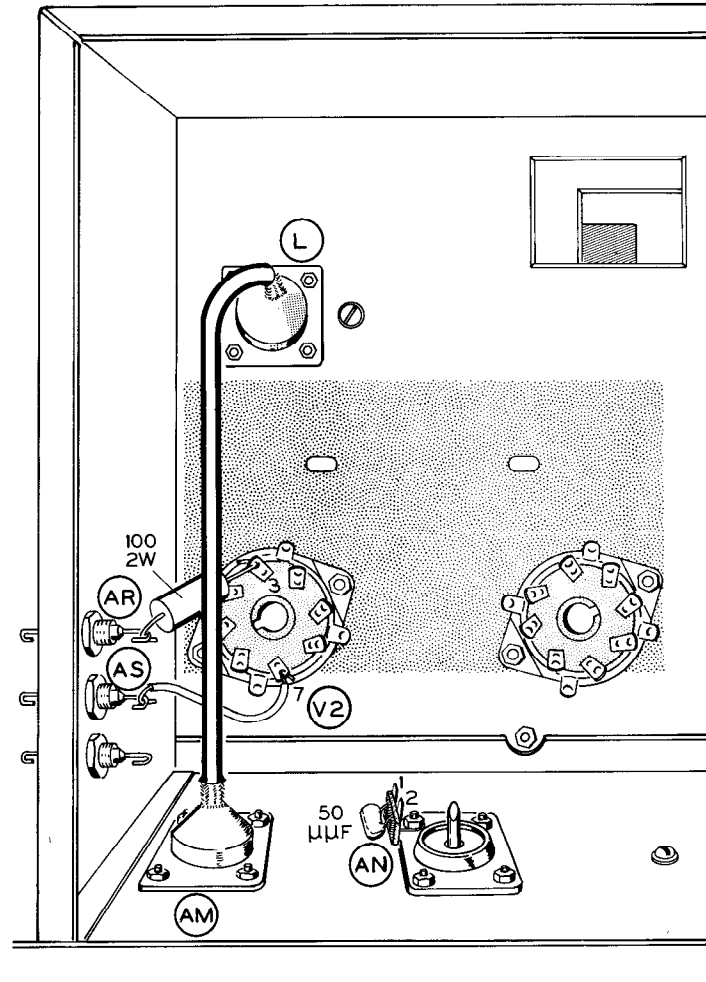

Pictorial 7

- () Connect the free end of the stranded wire coming from lug 7 of tube socket V2 to feedthrough capacitor AS (S-1).
- () R3. Connect a 100 Ω (brown-black-brown) 2 watt resistor from lug 3 of tube socket V2 (S-3) to feedthrough capacitor AR (S-1).

Refer to Detail 7A for the following steps.

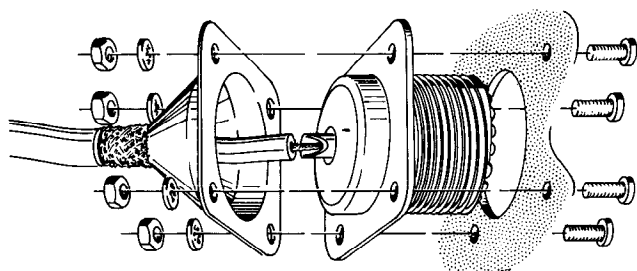

Detail 7A

- () Mount a coax connector at location AM with 3-48 x 1/4" hardware at one hole only.
- () Pass the coax connector shield, neck first, over the free end of the shielded cable extending from coax connector shield L.
- () Solder the inner conductor of the cable to the center lug of the coax connector at AM (S-1).
- () Remove the hardware holding coax connector AM in place.
- () Mount the coax connector and coax connector shield at AM. Use 3-48 x 1/4" hardware.
- () Form the braid of the shielded cable over the neck of the coax connector shield at AM and solder the braid to the shield. Use care not to short the inner conductor by applying too much heat.

NOTE: It would be advisable at this time to make an ohmmeter check between the chassis and the inner conductor of the shielded cable that extends from the coax connector shield at L from the top of the chassis to see that no short exists. If a short does exist, it should be corrected at this time.

- () C1. Connect a 50 $\mu\mu\text{f}$ resin dipped mica capacitor between lugs 1 (S-1) and 2 (NS) of terminal strip AN. Pass the leads of the capacitor through the bottom holes and around the lugs of the terminal strip.

INITIAL WIRING-TOP OF CHASSIS

Refer to Pictorial 8 for the following steps.

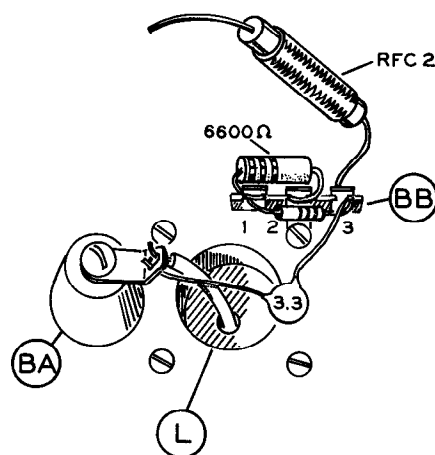

Pictorial 8

- () R6. Connect a 6800 Ω (blue-gray-red) 1/2 watt resistor between lugs 1 (NS) and 2 (S-1) of terminal strip BB.
- () D1. Connect the color band lead of the crystal diode (red-green-violet) to lug 3 (NS) and the other lead to lug 1 (S-2) of terminal strip BB. To protect the diode from heat damage, clip a pair of long-nose pliers on the diode lead between the body of the diode and the solder connection.
- () RFC2. Cut the lead at the end of the RF choke (#45-36) marked with the color dot to 1/2". Connect this lead to lug 3 of terminal strip BB (NS). Leave the other lead free.
- () C14. Connect a 3.3 $\mu\mu\text{f}$ disc ceramic capacitor from lug 3 of terminal strip BB (S-3) to the solder lug on standoff BA (NS).
- () Connect the free end of the inner conductor extending from coax connector shield L to the solder lug on standoff BA (NS).

Set the chassis aside temporarily.

ASSEMBLY-FINAL AMPLIFIER HOUSING

Refer to Pictorial 9 for the following steps.

() Mount eight 6-32 spade bolts on the final

amplifier housing (#206-M199). Use 6-32 x 1/4" hardware. Position the offset of each spade bolt as shown.

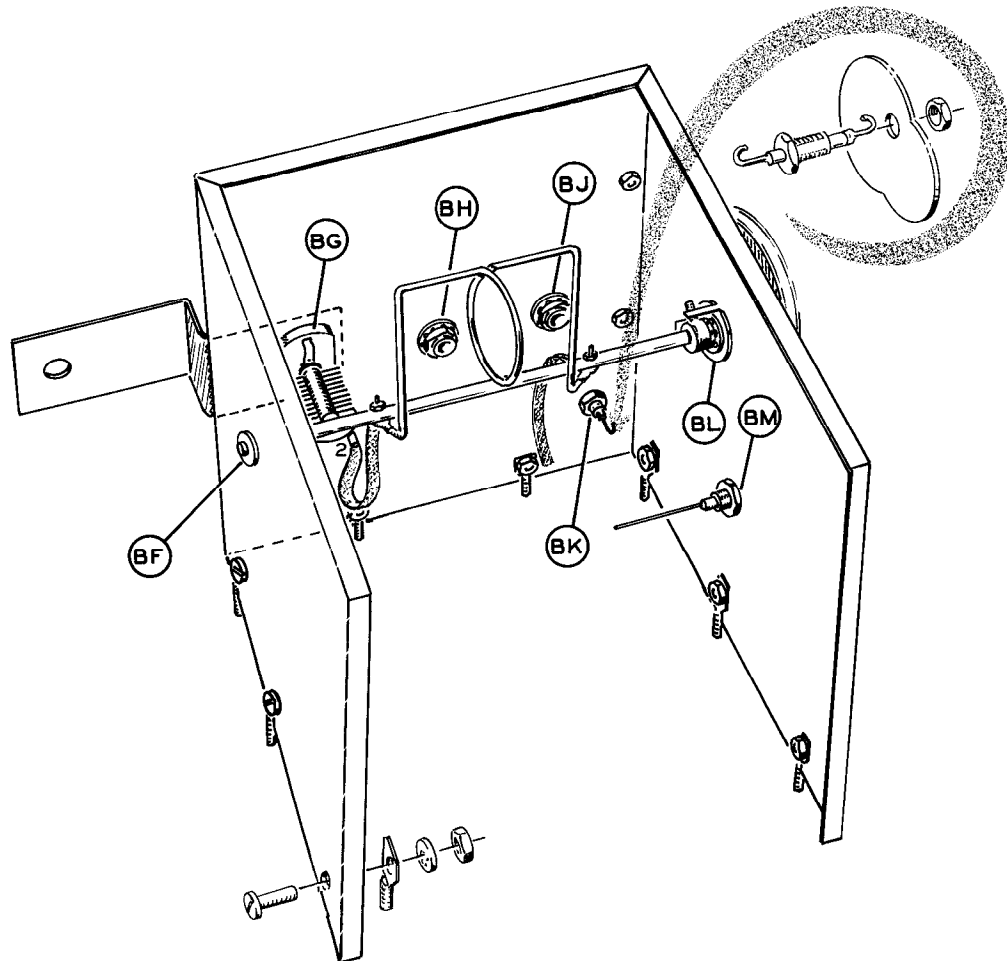

Pictorial 9

() C13. Referring to Detail 9A, mount the variable capacitor (#26-50) and the shaft support bracket (#204-M514) at location BG. Use the flat washer and nut supplied on the capacitor. Be sure to use the small hole in the bracket for mounting.

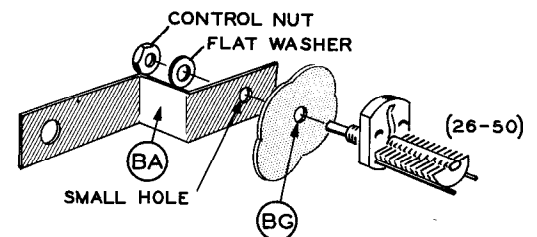

Detail 9A

- () Refer to Detail 9B and mount a hex flange 1/4" bushing at location BH. Use a control lockwasher and nut.
- () Mount a hex flange 1/4" bushing at location BJ. Use a control lockwasher and nut.
- () Install the 4-11/32" drive shaft in the bushing at location BJ. Use two E washers and the spring washer as shown.
- () C15. Mount a .001 μ fd (brown-black-red) feedthrough capacitor at location BK. Use the nut supplied on the capacitor.

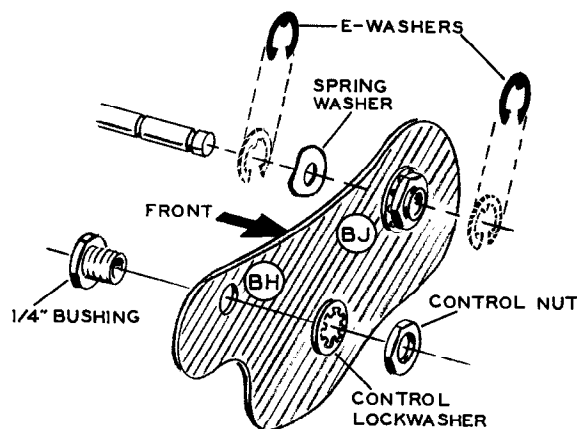

Detail 9B

- () Refer to Detail 9C and mount a round flange 1/4" bushing and the 90 degree rotational stop (#266-19) at location BL. Position the rotational stop as shown and use a control lockwasher and nut.
- () C16. Mount the .001 μ fd 1000 volt feed-through capacitor (brown-black-red-black) at location BM. Use the nut supplied on the capacitor.

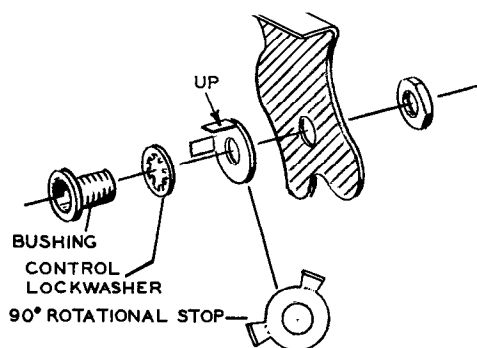

Detail 9C

Refer to Detail 9D for the following steps.

- () L3. Mount the link coupling coil (#40-140) and two small #6 solder lugs to the 6" insulated shaft. Use 3-48 x 1/2" hardware. Be sure the coil ends mount in the notches of the shaft.
- () Cut a 4" length of flat braid, open the end with a pointed object, and slip it over the solder lug near the long end of the insulated shaft (S-1). Bend this solder lug as shown.
- () In the same manner place a 3" length of flat braid over the solder lug near the short end of the insulated shaft (S-1). Bend this solder lug straight down as shown.
- () Start the 8-32 x 7/16" slotted setscrew in a shaft collar. Position the collar on the long end of the insulated shaft. Do not tighten.
- () Place a control nut and control lockwasher on the short end of the insulated shaft.

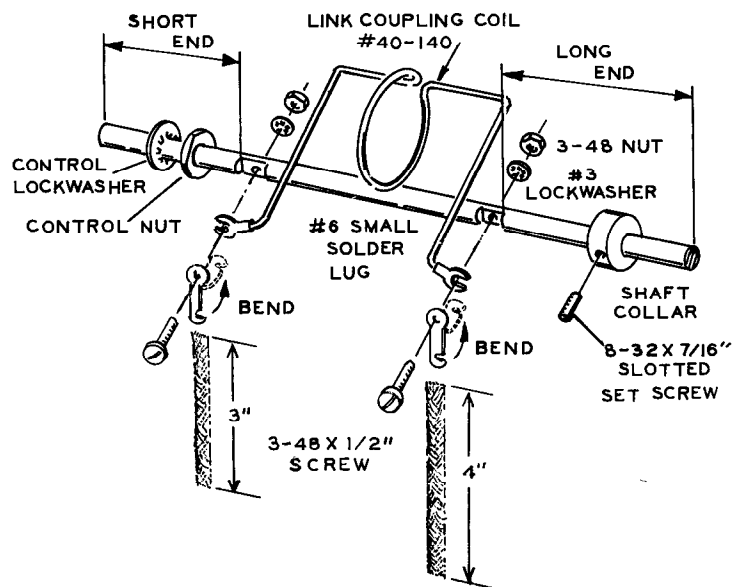

Detail 9D

- () Refer to Detail 9E and slide the short end of the insulated shaft into hole BF from inside of the final amplifier housing. Place the long end of the insulated shaft in bushing BL.
- () Mount a round flange 1/4" bushing in hole BF. Use the control lockwasher and nut on the insulated shaft.
- () Start an 8-32 x 1/4" allen setscrew in the large dial pulley (#100-M121). Place the pulley on the end of the insulated shaft. Position the coil and the opening of the pulley as shown and tighten the setscrew. Be sure the end of the shaft is flush with the edge of the pulley bushing.

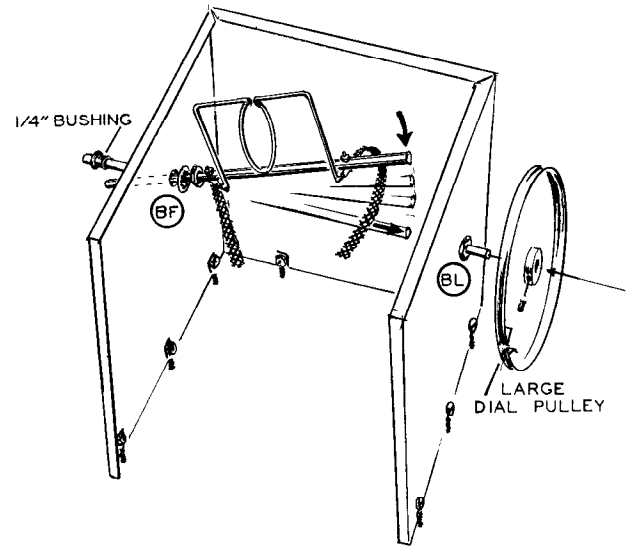

Detail 9E

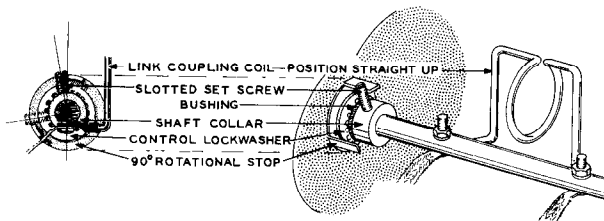

- () Push the insulated shaft into bushing BL until the large dial pulley is tight against the bushing. With the coil positioned as shown, push the shaft collar against the inside of bushing BL, then with the screw against the stop of the rotational stop, tighten the setscrew in the shaft collar.
- () Refer to Detail 9F and mount pulley bracket assemblies at positions BN and BP. Use 6-32 x 1/4" hardware. Position the pulley assemblies as shown.

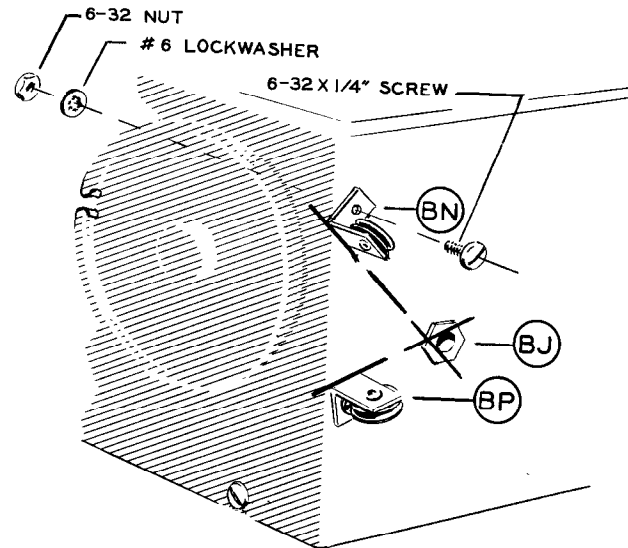

Detail 9F

INITIAL WIRING-FINAL AMPLIFIER

Refer to Pictorial 10 and Pictorial 11 (Page 26) for the following steps.

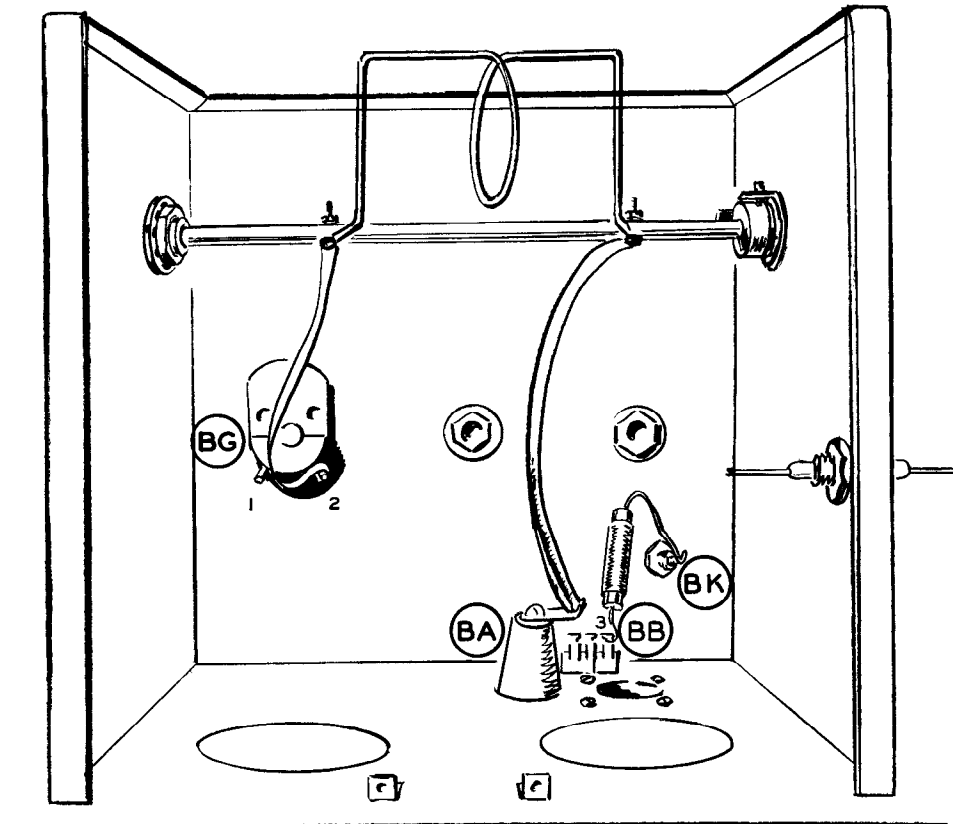

Pictorial 10

- () Mount the final amplifier housing assembly to the top of the chassis plate. Use #6 lockwashers and 6-32 nuts on the spade bolts.
 - () Solder the free end of the braid near the left end of the shaft to lug 2 of capacitor BG (S-1).
 - () Connect the free lead of the RF choke, coming from lug 3 of terminal strip BB, to feedthrough capacitor BK (S-1).
 - () Solder the free end of the other braid to the solder lug on the standoff BA (S-3).
 - () Tin the end of the braid extending from the insulated shaft.
- Be sure both braids clear all components when the large dial pulley is rotated back and forth.

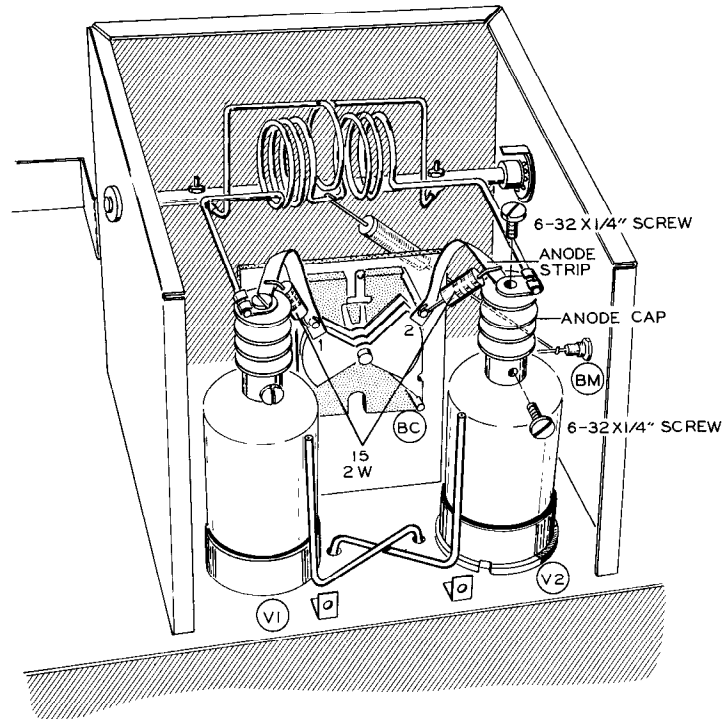

Pictorial 11

FINAL AMPLIFIER FINAL WIRING AND PARTS MOUNTING

Refer to Pictorial 11 for the following steps.

- () Refer to Detail 11A and mount two 6-32 spade bolts on the insulated capacitor mounting board. Use 6-32 x 3/8" hardware.
- () C12. Mount the variable capacitor (#26-48) at BC on the insulated capacitor mounting board. Use a control flat washer and the nut supplied on the capacitor.
- () Mount the insulated capacitor mounting board on top of the chassis plate, and the capacitor mounting bracket (#204-M513) on the bottom of the chassis plate. Use #6 lockwashers and 6-32 nuts on the spade bolts. Do not tighten.

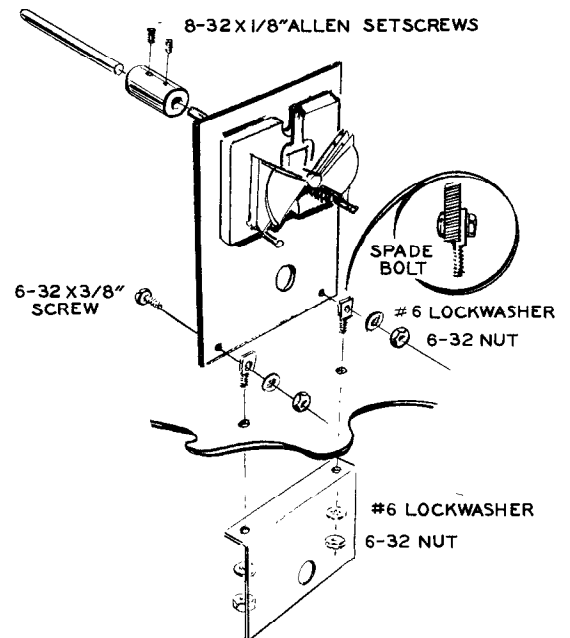

Detail 11A



() Refer to Detail 11B and start two 8-32 x 1/8" allen setscrews in an insulated shaft coupling. Position the shaft coupling on the shaft of capacitor BC so that it is 3/16" from the bushing of the capacitor and tighten.

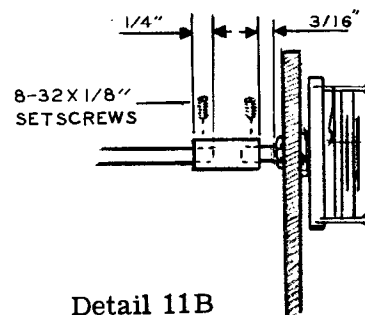

Detail 11B

() Make a pencil mark 1/4" from one end of the 3-3/4" insulated shaft extension. Pass this end of the shaft extension through bushing BH and into the insulated shaft coupling on capacitor BC to the pencil mark, then tighten the setscrew. Center the shaft in bushing BH and tighten the nuts that hold the insulated capacitor mounting board and capacitor mounting bracket to the chassis plate.

() Install the 6146 tubes in sockets V1 and V2. Bend the neutralizing stubs clear of the tubes.

() Mount the aluminum anode caps to the plate caps of the 6146 tubes. Use 6-32 x 1/4" screws. Tighten the screw just enough to hold the cap in place. Overtightening will damage the tubes.

() L4, RFC1. Locate the anode strips and coil assembly (#140-27). Mount the anode strip and one end of the coil assembly on each of the anode caps of the 6146 tubes. Use 6-32 x 1/4" screws. Do not tighten. Bend the anode strips so they fit over lugs 1 and 2 of variable capacitor BC. Be sure to place the screw in the hole nearest the end on the anode strips. Position the coil assembly so the link coupling of the coil assembly is centered in the wide space opening of the coil assembly and tighten the screws.

() R4. Connect a 15 Ω (brown-green-black) 2 watt resistor from the top of the anode strip as near the anode cap as possible of tube V1 (S-1) to lug 1 of variable capacitor BC (S-2). Be sure the anode strip is clear of the capacitor plates.

() R5. In a like manner, connect a 15 Ω (brown-green-black) 2 watt resistor from the top of the anode strip of tube V2 (S-1) to lug 2 of variable capacitor BC (S-2).

() RFC1. Connect the free lead of the RF choke coming from coil assembly L4 to feedthrough capacitor BM (S-1). Position the choke as shown.

NOTE: When rotating the large dial pulley back and forth, link coupling coil L3 may touch coil assembly L4 where the RF choke is connected. If this happens, loosen the collar and reposition it so it stops coil L3 about 1/8" from coil assembly L4, then retighten the setscrew in the collar.

Refer to Detail 11C for the following steps.

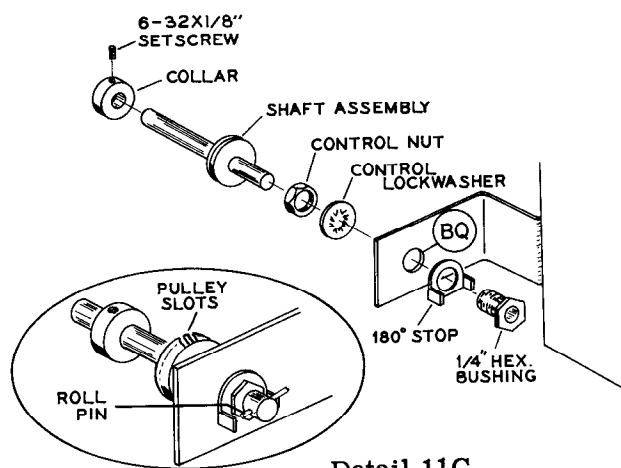

Detail 11C

() Mount a 1/4" hex bushing and 180 degree rotational stop (#266-18) at location BQ on the shaft support bracket. Use a control lockwasher and nut. Position the rotational stop as shown.

() Install the small dial pulley shaft assembly (#100-M162) in bushing BQ. Use the roll pin. Position the roll pin and the slots in the pulley as shown.

() Start an 8-32 x 1/8" allen setscrew in a shaft collar. Position the collar on the shaft of the dial pulley shaft assembly at BQ and tighten temporarily.

TOP OF CHASSIS-FINAL ASSEMBLY AND WIRING

Refer to Pictorial 12 for the following steps.

Connect the wires extending from grommet D as follows:

- () At the free end of the twisted stranded pair of wires, connect either wire in hole 1 (S-1) and the other in hole 2 (S-1) of the fan motor.

- () Connect the free end of the small hookup wire coming from lug 3 of control AE, to feedthrough capacitor BK (S-1).

- () Connect the free end of the short heavy hookup wire coming from lug 1 of terminal strip AQ, to feedthrough capacitor BM (NS). The two remaining wires will be connected later.

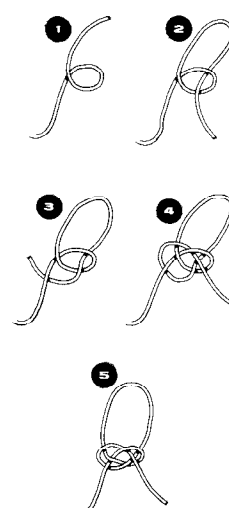
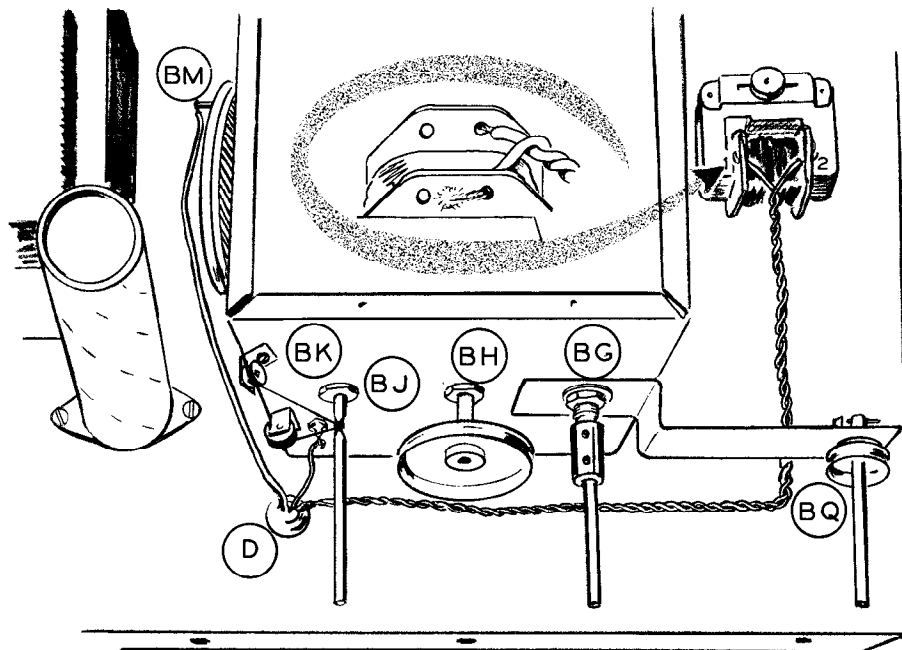

Pictorial 12

- () Refer to the inset drawing on Detail 12A and tie the knot illustrated in one end of the dial cord.
- () Referring to Detail 12A, hook the knotted end of the dial cord over the tab of the dial pulley as shown. String the dial pulley and shaft by following the numbers. At #9, place a dial cord spring on the other tab of the dial pulley. Place the dial cord through the other loop of the spring. Stretch the spring about 1/2" and tie a knot to the spring.

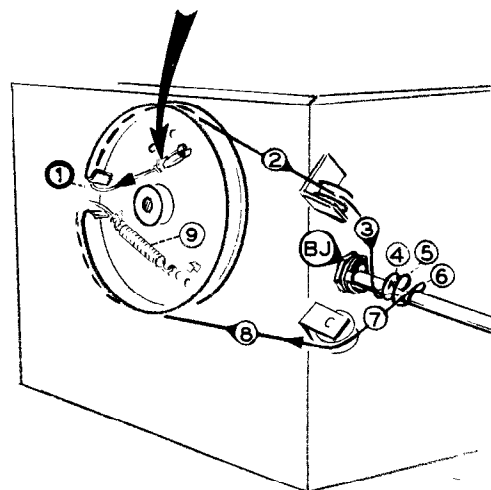

Detail 12A



- () Refer to Detail 12B and install the small dial pulley on the shaft extension extending from bushing BH. With the plates of variable capacitor BC fully meshed (closed), position the opening in the pulley as shown. Use an 8-32 x 1/4" allen setscrew. Be sure the pulley bushing is flush with the end of the shaft extension.
- () Referring to Detail 12B, follow the numbered steps and string the small dial pulley cord.
- () Start two 6-32 x 1/8" slotted setscrews in the metal shaft coupling.
- () Make a pencil mark 1/4" from the end of the 3-1/8" metal shaft extension. Place the metal shaft coupling on the shaft to the pencil mark and tighten the setscrew. Place the shaft coupling on the capacitor shaft extending from hole BG until the coupling is 3/8" from the final housing wall.
- () Install a 3/8" bushing at location AD. Use a control flat washer, lockwasher, and nut.
- () Snap the pilot lamp in place at location AA.
- () Loosen the setscrew in the collar on the dial shaft at BQ. Slide the collar up against bushing AW in the front panel and, with the shaft pushed in so the small pulley is against bushing BQ in the shaft support bracket, retighten the setscrew in the collar.
- () Turn the dial shafts of the COUPLING, FINAL, METER and METER ADJ controls fully counterclockwise. Adjust the LOADING shaft so that the plates of the variable capacitor controlled by the shaft are fully meshed.

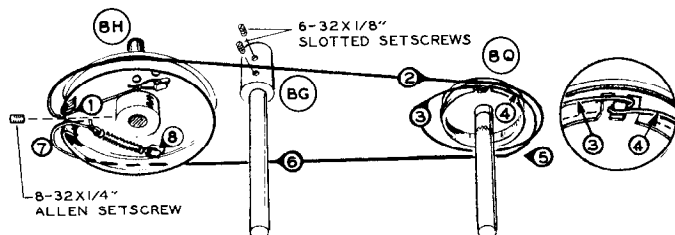

Detail 12B

- () Install large knobs on the COUPLING, LOADING and FINAL shafts with the knob pointer at the 9 o'clock position. Use two 8-32 x 1/4" allen setscrews in each knob.
- () Install small knobs on the METER and METER ADJ shafts with the knob pointer to the full counterclockwise marking on the panel. Use an 8-32 x 1/4" allen setscrew in each knob.

Refer to Pictorial 13 for the following steps.

- () Locate the front panel (#203-M328F822) and mount hex 3/8" bushings at locations AU, AV, and AW. Use control flat washers, lockwashers, and nuts.
- () Remove the nuts from switches AB and AC, and from control AE.
- () Install the front panel and control plate (#205-M388F821). Place flat control washers on switch AC and control AE, and replace the nuts on switches AB and AC and control AE.

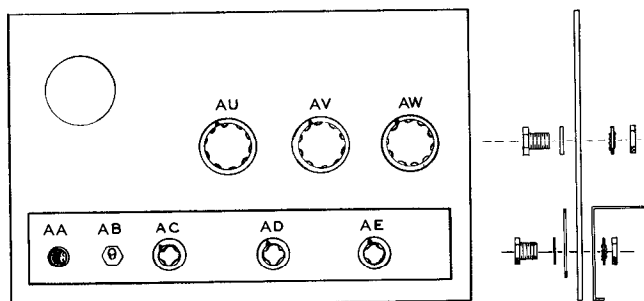

Pictorial 13

Refer to Detail 13A for the following steps.

- () Remove the meter from its box and mount it at location AX. Use the lockwashers and nuts supplied with the meter. Be careful not to overtighten as the meter may be damaged. Remove the shorting clip from between the meter terminals.
- () C17. Connect a .001 μ fd disc ceramic capacitor between lugs 1 (NS) and 2 (NS) of the meter.

Connect the free end of the two heavy hookup wires extending from grommet D as follows:

- () Connect the free end of the stripped wire from lug 2 of switch AC to lug 1 of meter AX (S-2).
- () Strip the free end of the remaining wire, coming from lug 8 of switch AC, and connect it to lug 2 of meter AX (S-2).

This completes the assembly and wiring on top of the chassis. Check all wiring to see that there are no errors and that all connections are soldered, except feedthrough capacitor BM.

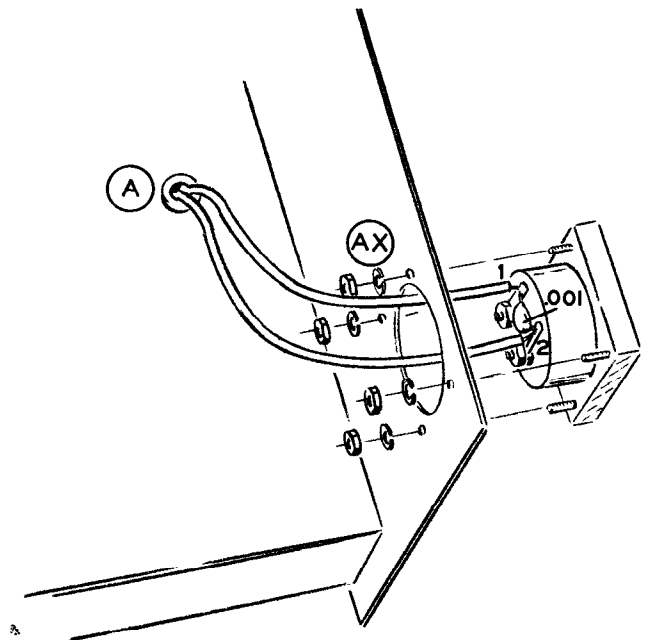

Detail 13A

FINAL WIRING-BOTTOM CHASSIS

Refer to Pictorial 14 for the following steps.

- () C22. Refer to Detail 14A and mount a 125 μ fd 450 V electrolytic capacitor at location F. Position the capacitor lug as shown. Twist the mounting tabs 1/8 turn.
- () C21. In a like manner, mount a 125 μ fd 450 V electrolytic capacitor at location G. Again position the capacitor lug as shown.

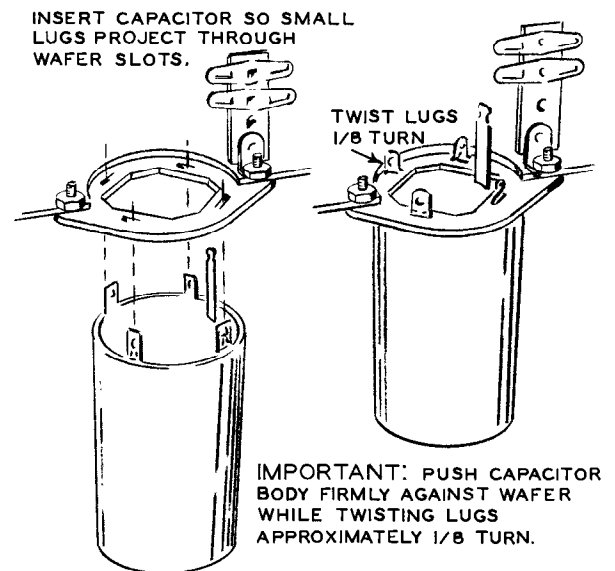

Detail 14A

Refer to Detail 14B for the following steps.

- () C4. Cut one lead of a 22 $\mu\mu\text{f}$ resin dipped capacitor to 1/4" and connect it to lug 3 (NS) of the variable capacitor (#26-39). Position the capacitor as shown and leave the other end free.
- () C5. Cut one lead of a 22 $\mu\mu\text{f}$ resin dipped capacitor to 1/4" and connect it to lug 3 (S-2) of the variable capacitor (#26-39). Position the capacitor as shown and leave the other end free.
- () C3. Mount the variable capacitor (#26-39) at location U on the capacitor mounting bracket. Position as shown and use the nut supplied on the capacitor.
- () Refer to Detail 14C and prepare the 6 meter link coupling coil (#40-345) as shown.

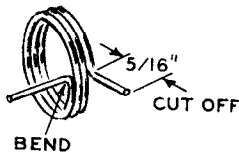
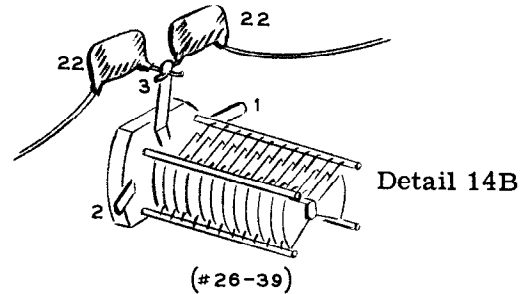

Detail 14C

- () Fill lug 1 of coax connector AP with solder.

CHANGE
() L1. Position the 6 meter link coupling coil as shown. Solder the short lead of the coil to lug 1 of coax connector AP, and the long lead to lug 2 of terminal strip AN (S-2).

Refer to Pictorial 14 for the following steps.

- () L2, R1. Position one lead of the coil assembly (#140-28) into lug 1 (NS) and the other lead into lug 2 (NS) of variable capacitor U. Center the coil carefully over the link coil. Be sure the coil assembly is still centered properly over the 6 meter link coupling coil.
- () Wrap the free lead of one of the capacitors coming from lug 3 of capacitor U around lug 1 of capacitor U (NS).
- () Connect the free lead of the other capacitor coming from lug 3 of capacitor U around lug 2 of capacitor U (NS).

- () Bend a small hook at one end of a 1-3/4" length of heavy buss wire. Fit the hook end over lug 1 of variable capacitor U (S-3) and position the other end against lug 5 of tube socket V2 (S-1).
- () In a like manner, connect another 1-3/4" length of heavy buss wire from lug 2 of capacitor U (S-3) to lug 5 of tube socket V1 (S-1).
- () Now bend the 6-meter link coupling coil down just enough so it does not touch the coil assembly connected to capacitor U.
- () Solder the free end of the 100 Ω resistor coming from the coil assembly to feed-through capacitor AT (S-1).
- () Start two 8-32 x 1/8" allen setscrews into an insulated shaft coupling. Push the split bushing and the shaft coupling all the way onto the shaft of variable capacitor U and tighten the setscrew. See the inset drawing on Pictorial 14.
- () Pass the 7" insulated shaft extension through bushing AD, the grid compartment shield, and all the way into the insulated shaft coupling on variable capacitor U. Tighten the setscrew.
- () Connect the free end of the yellow-blue lead from transformer T1 to ground lug A of capacitor F (S-1).
- () Connect the free end of the short red lead of transformer T1 to lug 1 of capacitor F (NS).
- () Connect the free end of the wire coming from lug 1 of terminal strip J to lug 1 of capacitor G (NS).
- () Connect the free end of the wire coming from lug 5 of terminal strip B to lug 1 of capacitor G (S-2).
- () Connect a 2" length of heavy hookup wire from lug 1 of capacitor F (NS) to ground lug C of capacitor G (NS).

- () R13. Connect a 2000 Ω 7 watt wire-wound resistor from lug 1 of terminal strip A (S-3) to lug 1 of capacitor F (NS).
- () R12. Connect a 100 K Ω (brown-black-yellow) 2 watt resistor from ground lug C (S-1) to lug 1 of capacitor F (S-4).
- () R11. Connect a 100 K Ω (brown-black-yellow) 2 watt resistor from lug 5 of terminal strip B (S-3) to ground lug C of capacitor G (S-2).
- () Connect one of the pilot lamp leads to lug 1 (S-4) and the other lead to lug 4 (NS) of terminal strip K.
- () At one end of the line cord, separate the leads for about 1-1/2". Strip off 1/4" insulation and tin the lead ends.
- () Pass the prepared line cord end through hole AF. Connect one lead to lug 3 (S-5) and the other to lug 1 (S-3) of terminal strip K.
- () Refer to Detail 14D and install the line cord strain relief in hole AF.

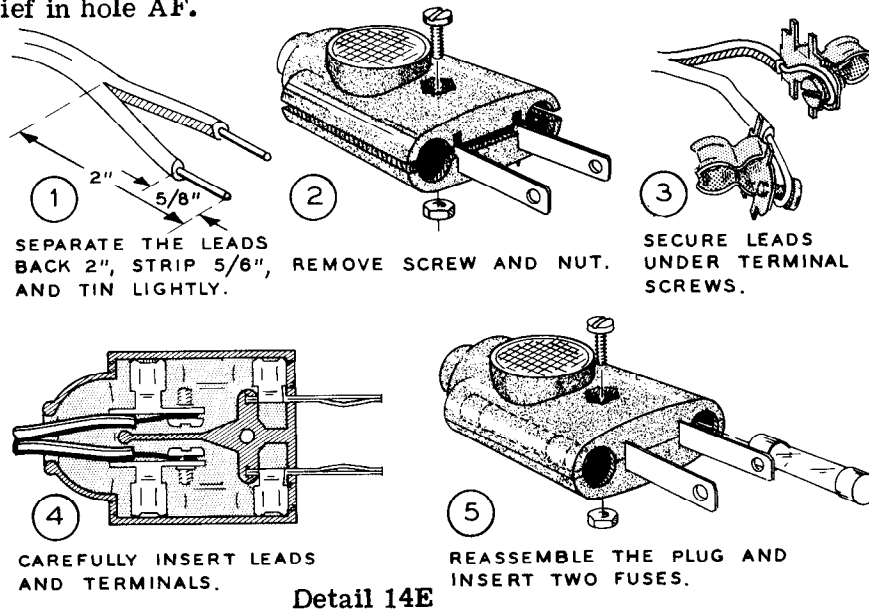
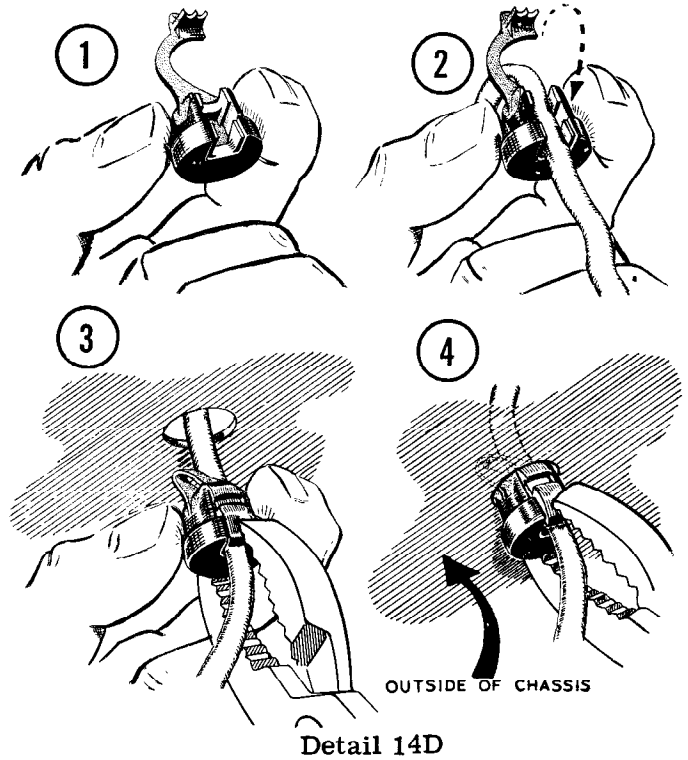

- () Refer to Detail 14E and install the line plug on the free end of the line cord.
- () Install both fuses in the line plug.

This completes the wiring of your Linear Amplifier. Check all wiring and soldering. All connections should be soldered except lug 3 of

terminal strip AQ and feedthrough BM. Shake out any wire clippings or solder splashes.

- () Refer back to Pictorial 13, turn the GRID shaft so the plates of capacitor U are fully meshed, and install a small knob on the GRID shaft with the pointer at the fully counterclockwise dial marking. Use an 8-32 x 1/4" allen setscrew.

ADJUSTMENTS

PRELIMINARY CHECK

(See Pictorial 14 fold-out from Page 30.)

Set the controls for these checks as follows:

POWER: Off,

METER: Grid

GRID: 0

METER ADJ: 0

COUPLING - Full counterclockwise

LOADING : 0

FINAL: 0

BIAS ADJUST: Full CCW

CUT OFF BIAS JACK: Open

Using a 20 K Ω per volt or higher ohmmeter, make the following checks.

NEGATIVE LEAD TO POINT	POSITIVE LEAD TO POINT	RESISTANCE
Lug 2 of K	Lug 4 of K	Infinite.
Chassis ground	Lug 1 of B	230 Ω .
Chassis ground	Lug 5 of B	At least 150 K Ω after 5 seconds.
Lug 4 of C	Lug 1 of B	Approximately 30 K Ω .
Lug 1 of B	Lug 4 of C	Appreciably lower than the previous reading with the meter on the same range. This reading is dependent on the voltage impressed across the diode and will vary if range setting of meter is changed.
Chassis ground	Feedthrough AR	Approximately 50 K Ω after 10 seconds.
Chassis ground	Feedthrough AS	Approximately .1 Ω (will show zero on most meters).
Chassis ground	Feedthrough AT	Approximately 27 K Ω .

If any of the above readings cannot be obtained, refer to the In Case Of Difficulty section of the manual on Page 38.

CAUTION: IN A LINEAR AMPLIFIER, LETHAL VOLTAGES ARE PRESENT. CONSEQUENTLY, GREAT CARE MUST BE EXERCISED WHEN ANY TESTS OR ADJUSTMENTS ARE MADE.

NOTE: If at any time while making the adjustments, the Amplifier does not perform as it should, refer to the In Case Of Difficulty section.

Refer to Detail 14F for the following steps.

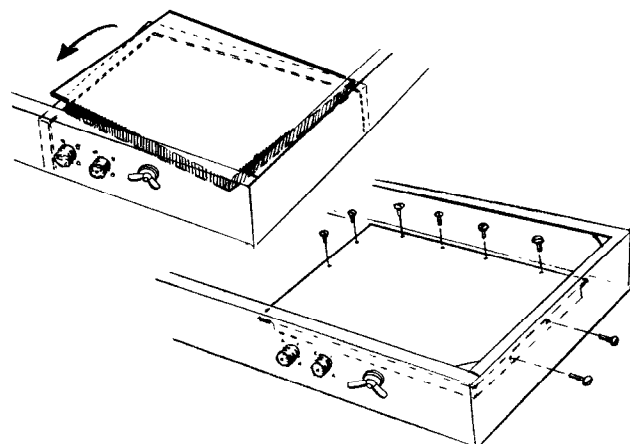

Detail 14F

- () Install the bottom plate (#205-M387) over the grid compartment. Use #6 x 3/8" sheet metal screws in the holes as shown.

- () Refer to Detail 14G and install the final amplifier rear shield (#206-M81). Use six #6 x 3/8" sheet metal screws and two 6-32 x 1/4" screws as shown.

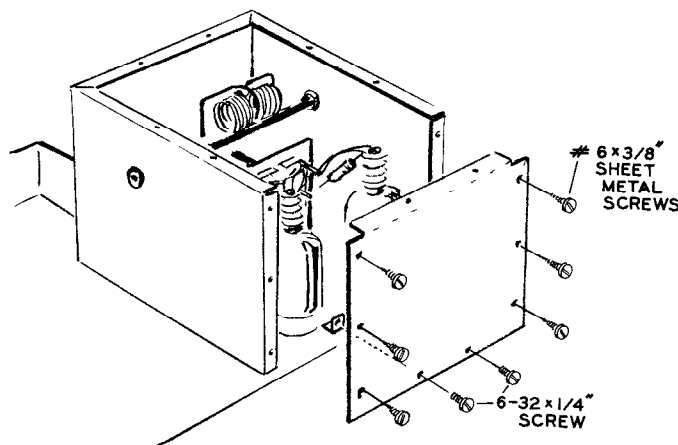

Detail 14G

METER SWITCH POSITION	MEASURES	RANGE	SCALE
GRID	GRID CURRENT	0 - 0.6 ma	LOWER
PWR	Relative voltage developed in transmission line.	0-1000 Adjustable by Meter Adjust control.	TOP
MA	Plate current.	0-400 ma	MIDDLE
HV	Plate voltage.	0-1000 V DC	TOP

- () Install the 6A2 tube in tube socket V3.

BIAS SETTING

- () Place the METER switch in the MA position.
- () Short the CUTOFF BIAS jack to the chassis. A shorted phono plug could be used for this purpose.
- () Connect a 50 to 75 Ω nonreactive load such as the Heathkit Dummy Load, to the OUTPUT connector.

- () Turn the Amplifier on.

- () Set the BIAS ADJUST control to a position that gives a meter reading of 50 ma of current flow through the final amplifiers with normal standby conditions of the exciter (with no drive applied).

NOTE: Never operate the Amplifier unless a 50 to 75 Ω dummy load or antenna is connected to the OUTPUT jack.

NEUTRALIZING

- () Under the chassis, locate the hookup wire connected between lug 3 of terminal strip AQ and feedthrough capacitor AR. Disconnect the end of this wire from capacitor AR.
- () On top of the chassis, disconnect the heavy hookup wire from feedthrough capacitor BM. Position this wire away from the chassis, and do not touch it while making the following adjustments as there is High Voltage on this wire.
- () Connect a VTVM to the OUTPUT jack on the rear apron and set it to a low AC voltage range.
- () Connect an exciter to the INPUT jack of the Amplifier and turn both units on.
- () Set the METER switch to the GRID position.
- () Turn the COUPLING control until the link coil is fully inserted into the final coil.
- () Apply drive from the exciter until grid current flow is indicated on the meter.
- () Adjust the FINAL control for maximum indication on the VTVM.
- () Using an insulated tool (the nut starter supplied with the kit), bend the neutralizing stubs away from the tubes and toward each other, until a minimum indication is obtained on the VTVM. This minimum indicates that the stages are neutralized.
- () Retune the FINAL control for maximum meter indication and repeat the neutralizing stub adjustment. If the neutralizing stubs tend to cross each other, clip off both stubs the same amount (about 1/4") and repeat the above operation.
- () Turn the Amplifier off.

CAUTION: ALLOW TIME FOR HIGH VOLTAGE TO BLEED OFF BEFORE ATTEMPTING THE FOLLOWING STEPS.

- () Reconnect the wire to capacitor AR (S-1).
- () Reconnect the wire to feedthrough capacitor BM and solder (S-1).
- () Disconnect the VTVM from the output jack.

CW

- () 1. Set the METER switch to MA and apply drive from the exciter until 80 ma of plate current is obtained.
- () 2. Turn the METER switch to PWR.
- () 3. Turn the METER ADJ control to the 9 o'clock position.

NOTE: With the meter switch in the PWR position, the meter adjust control may be used to keep the meter from going off scale.

- () 4. Turn the COUPLING control clockwise until some indication of output is indicated.
- () 5. Adjust the GRID control for maximum meter indication.
- () 6. Tune the LOADING control for maximum meter indication.
- () 7. Tune the FINAL control for maximum meter indication.
- () 8. Alternately adjust the COUPLING and FINAL controls until a maximum meter indication (power) is obtained.
- () 9. Change the METER switch to the GRID position and adjust the GRID control for a meter reading of .3 ma grid current (0.6 ma = full scale). Plate current will be approximately 80 milliamperes. It may be necessary to peak the exciter to obtain this reading.

NOTE: If .3 ma cannot be obtained, check coupling between the grid coil assembly and the link input coil. Increase this coupling as necessary. See Pictorial 14 (fold-out from Page 30).

SSB

- () Tune the Amplifier as for CW, following steps 1 through 9.
- () Switch the exciter to the SSB position.
- () Change the METER switch to the GRID position.
- () Advance the audio control on the exciter until a "flickering" is noted on the meter of the Amplifier. (Should not rise above 2 divisions on meter.) Plate current on peaks will be approximately 100 milliamperes.

AM

- () Tune the Amplifier the same as for CW, following steps 1 through 9.
- () Set the REL PWR METER adjust control for full scale, 1000.
- () Reduce drive from the exciter until the meter reads 500. This maintains the amplifier at the proper level to allow 100% modulation without overdriving. You are now ready for AM operation.

NOTE: If there are no provisions in the exciter to reduce input power, refer to Figure 1 which shows a schematic for a suitable 6 db pad for AM operation. The 6 db pad should be connected between the exciter and the Amplifier. The Amplifier should be tuned with the pad switch in the CW, SSB position and then switched to AM before proceeding with modulation.

CABINET INSTALLATION

- () Refer to Detail 14H and install the final amplifier top shield (#206-M82). Use #6 x 3/8" sheet metal screws.

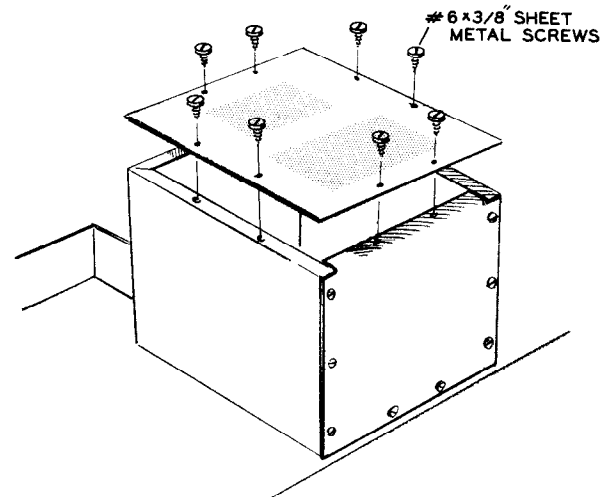

Detail 14H

- () Refer to Detail 14J and mount the four rubber feet on the cabinet. Use 8-32 x 3/8" hardware.
- () Place the Amplifier in front of the cabinet and pass the line cord through the opening in the back of the cabinet. Now slide the Amplifier onto the rails and into the cabinet while guiding the line cord out the rear opening. Use ten 10-32 x 3/8" phillips head screws to fasten the front panel to the cabinet. Use eight #6 sheet metal screws through the back of the cabinet into the rear of the chassis.

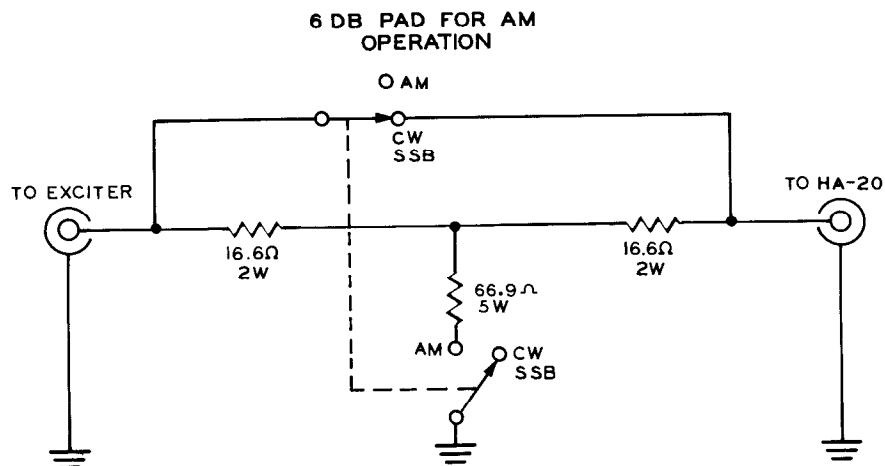
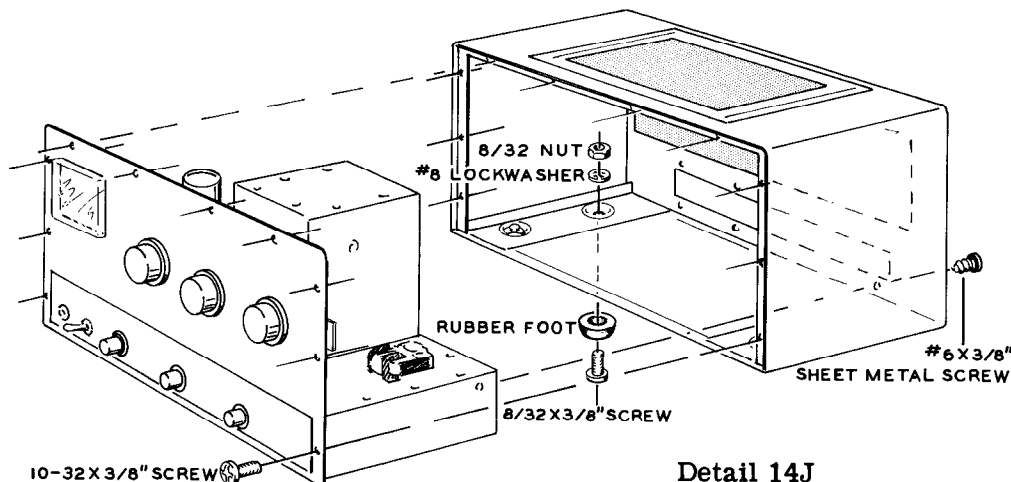

Figure 1



Detail 14J

INSTALLATION

Refer to Figure 2 for clarification of the following information.

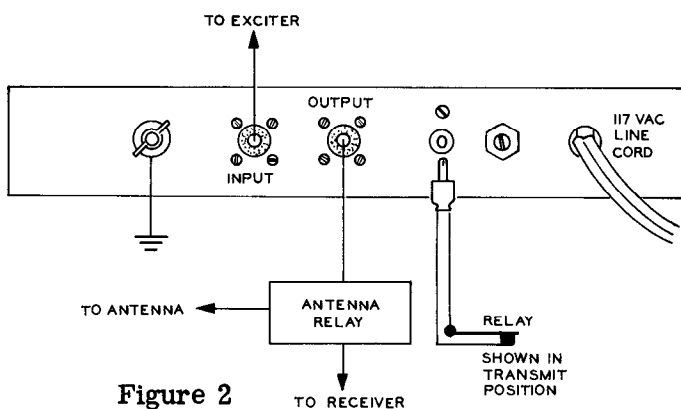

Figure 2

LOCATION

Although the Amplifier has a built-in fan for cooling purposes, avoid excessively warm locations such as those near radiators and heating vents. The Amplifier should be placed in a location that provides adequate space around it, permitting free air circulation through the cabinet openings.

CUT-OFF BIAS

To avoid standby tube noise and possible instability when the antenna is disconnected from the Amplifier during receive operation, the 6146 tubes should be biased to cutoff. This will also reduce heat and power consumption. To actuate the built-in bias supply of the Amplifier, the CUTOFF BIAS jack must be unground-

ed. A pair of relay terminals (possibly the antenna relay) can be used for this purpose. The relay terminals would have to be in the closed position for the Amplifier to transmit. The Heathkit 6-meter exciter has a relay for this purpose.

EXCITER

This Amplifier can be driven by most any commercial or home-built exciter, including 50 Ω fixed output impedance types, having a power output of 7 to 10 watts. For exciters having a lower output, see the Schematic and Page 16 for reference to resistor R2 value changes.

For AM operation it is necessary to reduce the exciter output power by 3/4 (Rel PWR meter indication would be reduced by 1/2, as this measurement is developed from voltage not power). If the exciter used does not have provisions to reduce the input power, we suggest that the 6 db pad (1/4 power = 1/2 voltage for 6 db attenuation) shown in Figure 1 be used. With the pad, load the amplifier in the CW or SSB position, and then switch to AM before proceeding with modulation.

ANTENNA

The Amplifier is designed to work into a 50 to 75 Ω transmission line. Most commercial and home built antennas are designed to be fed with 50 to 75 Ω coax. RG-8/U or RG-11/U coax cable is recommended for the transmission line and every effort should be made to get the SWR of the antenna down to less than 2 to 1.

IN CASE OF DIFFICULTY

1. Recheck the wiring. Trace each lead in colored pencil on the Pictorial as it is checked. It is frequently helpful to have a friend check your work. Someone who is not familiar with the unit may notice something consistently overlooked by the constructor.
2. It is interesting to note that about 90% of the kits that are returned for repair, do not function properly due to poor connections and soldering. Therefore, many troubles can be eliminated by reheating all connections to make sure that they are soldered as described in the Proper Soldering Techniques section of this manual.
3. Check to be sure that all tubes are in their proper locations. Make sure that all tubes light up properly.
4. Check the tubes with a tube tester or by substitution of tubes of the same types and known to be good.
5. Check the values of the parts. Be sure that the proper part has been wired into the circuit, as shown in the pictorial diagrams and as called out in the wiring instructions.
6. Check for bits of solder, wire ends or other foreign matter which may be lodged in the wiring.
7. If, after careful checks, the trouble is still not located and a voltmeter is available, check voltage readings against those shown on the Schematic Diagram. NOTE: All voltage readings were taken with an 11 megohm input vacuum tube voltmeter. Voltages may vary as much as 10%.
8. A review of the Circuit Description will prove helpful in indicating where to look for trouble.

TROUBLESHOOTING CHART	
DIFFICULTY	CAUSE
Pilot light fails to glow.	<ol style="list-style-type: none"> 1. Check fuses. 2. Check wiring of terminal strip K.
No filament voltage (6146 tubes only).	<ol style="list-style-type: none"> 1. Incorrect wiring of lugs 2 or 7 of V1 or V2. 2. Check wiring of power transformer T1.
OA2 tube does not glow.	<ol style="list-style-type: none"> 1. Open resistor R20. 2. Incorrect wiring of socket V3.

No resting plate current.	<ol style="list-style-type: none"> 1. Check B+ voltage of V1 and V2. 2. Check screen voltage of V1 and V2.
Low or no high voltage.	<ol style="list-style-type: none"> 1. Check polarity of diodes.
No control over resting plate current.	<ol style="list-style-type: none"> 1. Cutoff bias jack not shorted. 2. Wiring error in bias supply circuit. 3. Check wiring of bias control.
Resting plate current erratic.	<ol style="list-style-type: none"> 1. Check neutralizing. 2. Check bias wiring. 3. Check grid input for short to ground.
Unable to dip final amplifier (meter in MA position).	<ol style="list-style-type: none"> 1. Incorrect final tank LC ratio. (Check with grid dip meter for resonant frequency.) (This may be due to pressures exerted during assembly and may be corrected by carefully squeezing the final tank coil assembly to reduce turn spacing.) 2. Defective 6146 tube.
Excessive plate current.	<ol style="list-style-type: none"> 1. Final tank coil not tuned to resonance. 2. Link coupling coil shorting to final tank coil. 3. Shorted feedthrough capacitor C16. 4. Defective 6146 tube.
Unable to load properly.	<ol style="list-style-type: none"> 1. Coax cable from final amplifier compartment to output connector shorted. 2. Impedance of transmission line incorrect (must be 50 to 75 Ω from linear amplifier). 3. Impedance match from antenna to Amplifier, or from dummy load to Amplifier or transmission line incorrect. 4. Open or shorted transmission line. 5. Final amplifiers not neutralized. 6. Defective 6146 tube.
Unable to get GRID indication of .3 milliamperes.	<ol style="list-style-type: none"> 1. Exciter improperly tuned. 2. Exciter output not matched to amplifier input. 3. Low exciter output. 4. Grid circuit improperly wired. 5. Grid circuit LC ratio incorrect (this may be due to pressures exerted during assembly and may be corrected by carefully squeezing the grid coil assembly to reduce turn spacing). 6. Coupling between grid coil assembly and input link coil insufficient. 7. Defective 6146 tubes.

SERVICE INFORMATION

SERVICE

If, after applying the information in this manual and your best efforts, you are still unable to obtain proper performance, it is suggested that you take advantage of the technical facilities which the Heath Company makes available to its customers.

The Technical Consultation Department is maintained for your benefit. This service is available to you at no charge. Its primary purpose is to provide assistance for those who encounter difficulty in the construction, operation or maintenance of HEATHKIT equipment. It is not intended, and is not equipped to function as a general source of technical information involving kit modifications nor anything other than the normal and specified performance of HEATHKIT equipment.

Although the Technical Consultants are familiar with all details of this kit, the effectiveness of their advice will depend entirely upon the amount and the accuracy of the information furnished by you. In a sense, **YOU MUST QUALIFY** for GOOD technical advice by helping the consultants to help you. Please use this outline:

1. Before writing, fully investigate each of the hints and suggestions listed in this manual under In Case Of Difficulty. Possibly it will not be necessary to write.
2. When writing, clearly describe the nature of the trouble and mention all associated equipment. Specifically report operating procedures, switch positions, connections to other units, and anything else that might help to isolate the cause of trouble.
3. Report fully on the results obtained when testing the unit initially and when following the suggestions under In Case Of Difficulty. Be as specific as possible and include voltage readings if test equipment is available.
4. Identify the kit model number and date of purchase, if available. Also mention the date of the kit assembly manual. (Date at bottom of Page 1.)
5. Print or type your name and address, preferably in two places on the letter.

With the preceding information, the consultant will know exactly what kit you have, what you would like it to do for you and the difficulty you wish to correct. The date of purchase tells him whether or not engineering changes have been made since it was shipped to you. He will know what you have done in an effort to locate the cause of trouble and, thereby, avoid repetitious suggestions. In short, he will devote full time to the problem at hand, and through his familiarity with the kit, plus your accurate report, he will be able to give you a complete and helpful answer. If replacement parts are required, they will be shipped to you, subject to the terms of the Warranty.

The Factory Service facilities are also available to you, in case you are not familiar enough with electronics to provide our consultants with sufficient information on which to base a diagnosis of your difficulty, or in the event that you prefer to have the difficulty corrected in this manner. You may return the completed equipment to the Heath Company for inspection and necessary repairs and adjustments. You will be charged a minimal service fee, plus the price of any additional parts or material required. However, if the completed kit is returned within the Warranty period, parts charges will be governed by the terms of the Warranty. State the date of purchase, if possible.

Local Service by Authorized HEATHKIT Service Centers is also available in some areas and often will be your fastest, most efficient method of obtaining service for your HEATHKIT equipment. Although charges for local service are generally somewhat higher than for factory service, the amount of increase is usually offset by the transportation charge you would pay if you elected to return your kit to the Heath Company.

HEATHKIT Service Centers will honor the regular 90 day HEATHKIT Parts Warranty on all kits, whether purchased through a dealer or directly from Heath Company; however, it will be necessary that you verify the purchase date of your kit.

Under the conditions specified in the Warranty, replacement parts are supplied without charge; however, if the Service Center assists you in locating a defective part (or parts) in your kit, or installs a replacement part for you, you may be charged for this service.

HEATHKIT equipment purchased locally and returned to Heath Company for service must be accompanied by your copy of the dated sales receipt from your authorized HEATHKIT dealer in order to be eligible for parts replacement under the terms of the Warranty.

THIS SERVICE POLICY APPLIES ONLY TO COMPLETED EQUIPMENT CONSTRUCTED IN ACCORDANCE WITH THE INSTRUCTIONS AS STATED IN THE MANUAL. Equipment that has been modified in design will not be accepted for repair. If there is evidence of acid core solder or paste fluxes, the equipment will be returned NOT repaired.

For information regarding modification of HEATHKIT equipment for special applications, it is suggested that you refer to any one or more of the many publications that are available on all phases of electronics. They can be obtained at or through your local library, as well as at most electronic equipment stores. Although the Heath Company sincerely welcomes all comments and suggestions, it would be impossible to design, test, evaluate and assume responsibility for proposed circuit changes for special purposes. Therefore, such modifications must be made at the discretion of the kit builder, using information available from sources other than the Heath Company.

REPLACEMENTS

Material supplied with HEATHKIT products has been carefully selected to meet design requirements and ordinarily will fulfill its function without difficulty. Occasionally, improper operation can be traced to a faulty component. Should inspection reveal the necessity for replacement, write to the Heath Company and supply all of the following information.

A. Thoroughly identify the part in question by using the part number and description found in the manual Parts List.

- B. Identify the type and model number of kit in which it is used.
- C. Mention date of purchase.
- D. Describe the nature of defect or reason for requesting replacement.

The Heath Company will promptly supply the necessary replacement. **PLEASE DO NOT RETURN THE ORIGINAL COMPONENT UNTIL SPECIFICALLY REQUESTED TO DO SO.** Do not dismantle the component in question as this will void the guarantee. This replacement policy does not cover the free replacement of parts that may have been broken or damaged through carelessness on the part of the kit builder.

SHIPPING INSTRUCTIONS

In the event that your instrument must be returned for service, these instructions should be carefully followed.

Wrap the equipment in heavy paper, exercising care to prevent damage. Place the wrapped equipment in a stout carton of such size that at least three inches of shredded paper, excelsior, or other resilient packing material can be placed between all sides of the wrapped equipment and the carton. Close and seal the carton with gummed paper tape, or alternately, tie securely with stout cord. Clearly print the address on the carton as follows:

To: **HEATH COMPANY**
Benton Harbor, Michigan

ATTACH A LETTER TO THE OUTSIDE OF THE CARTON BEARING YOUR NAME, COMPLETE ADDRESS, DATE OF PURCHASE, AND A BRIEF DESCRIPTION OF THE DIFFICULTY ENCOUNTERED. Also, include your name and return address on the outside of the carton. Preferably affix one or more "Fragile" or "Handle With Care" labels to the carton, or otherwise so mark with a crayon of bright color. Ship by insured parcel post or prepaid express; note that a carrier cannot be held responsible for damage in transit if, in HIS OPINION, the article is inadequately packed for shipment.

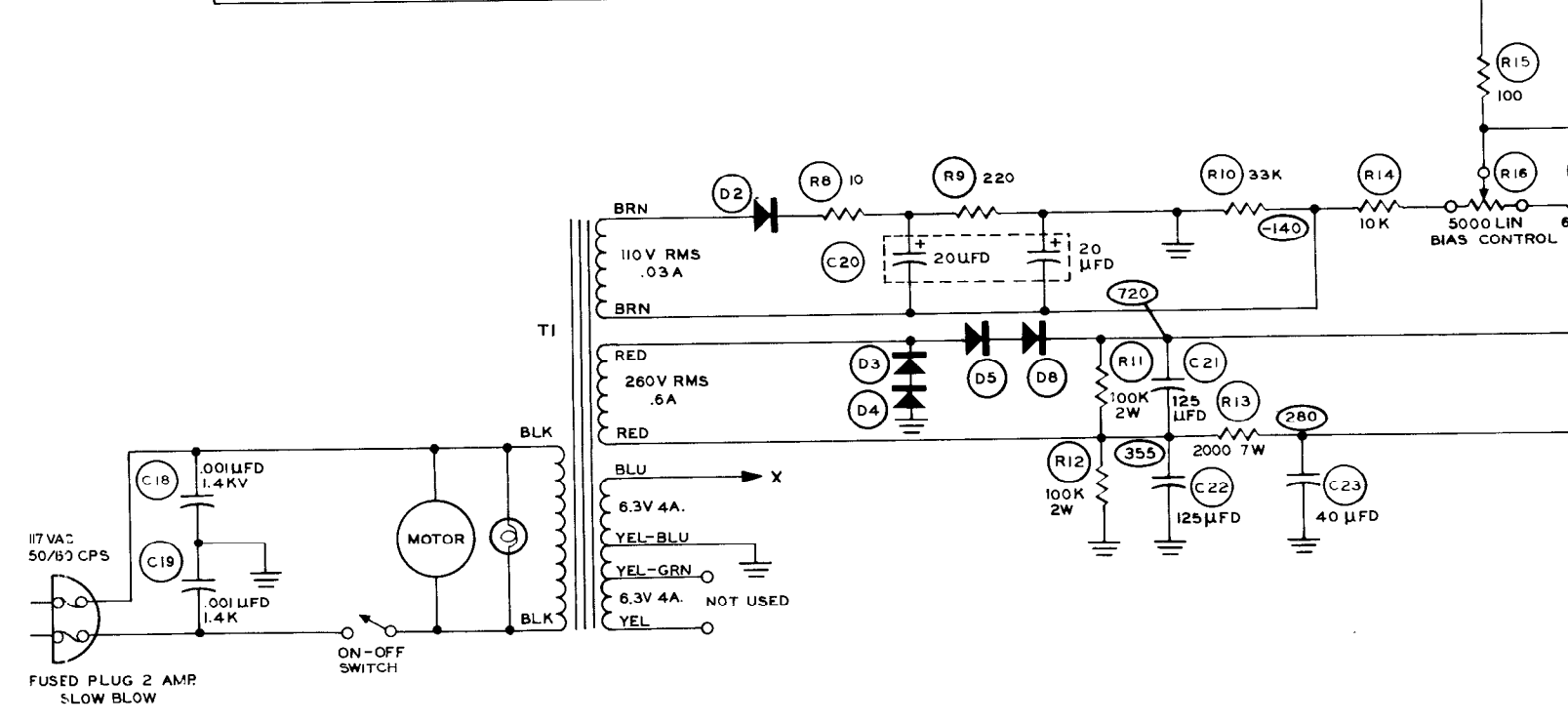
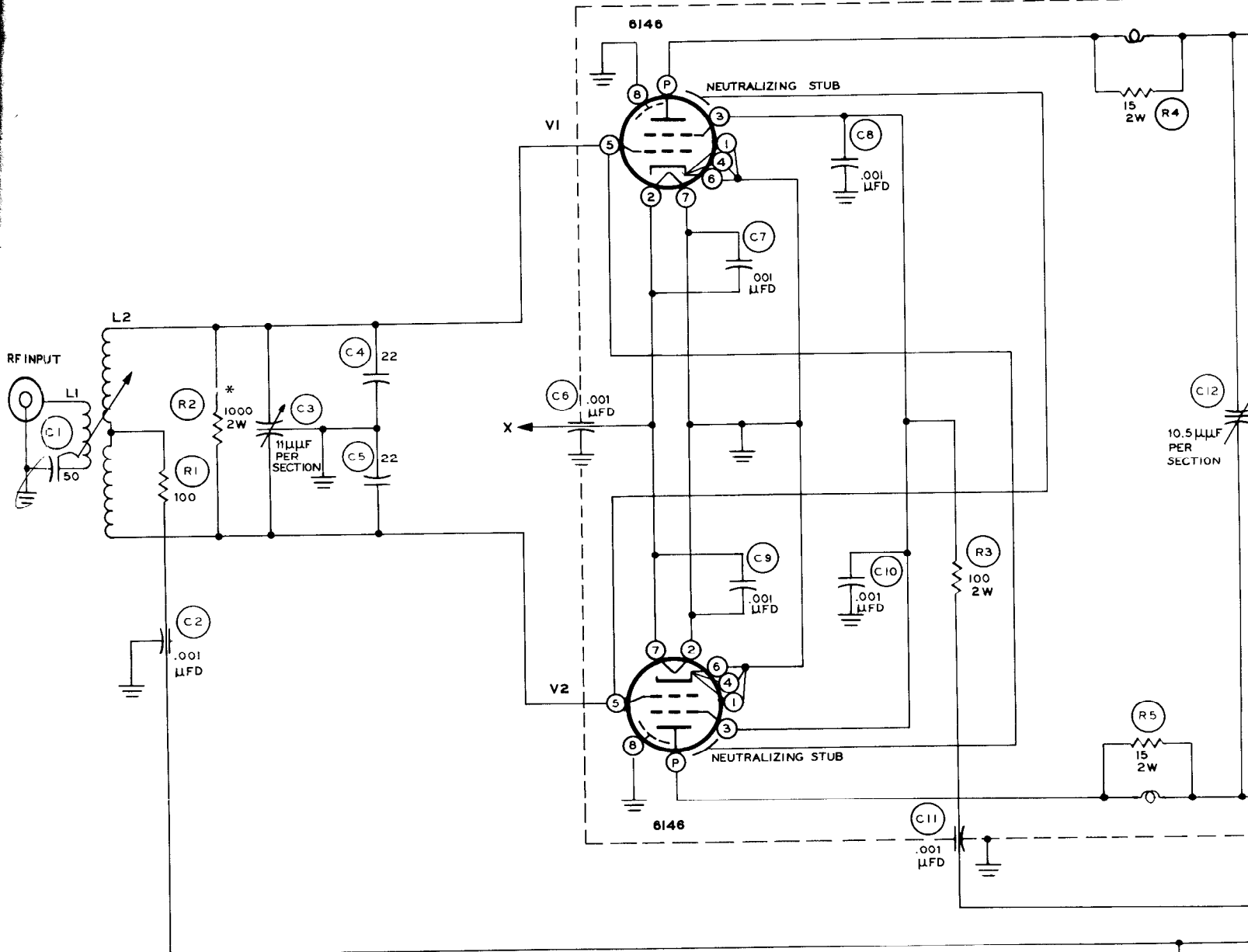

SCHEMATIC OF THE HEATHKIT® 6 METER LINEAR AMPLIFIER MODEL HA-20

GENERAL INFORMATION

METER SWITCH SHOWN IN GRID POSITION.
ALL VOLTAGES MEASURED WITH 11 MEGOHM INPUT VTVM.
VOLTAGES MEASURED WITH CUTOFF BIAS JACK OPEN.
ALL RESISTORS ARE 1/2 WATT UNLESS SPECIFIED OTHERWISE.
ALL CAPACITORS ARE IN μfd UNLESS SPECIFIED OTHERWISE.
*VALUE SHOWN IS FOR 7 TO 10 WATT EXCITER, FOR AN
EXCITER OF 2.5 WATTS RATED OUTPUT, THE VALUE WOULD
BE 2200 Ω , 2 WATT.

○ ALL VOLTAGES ARE DC AND MEASURED FROM CHASSIS GROUND.

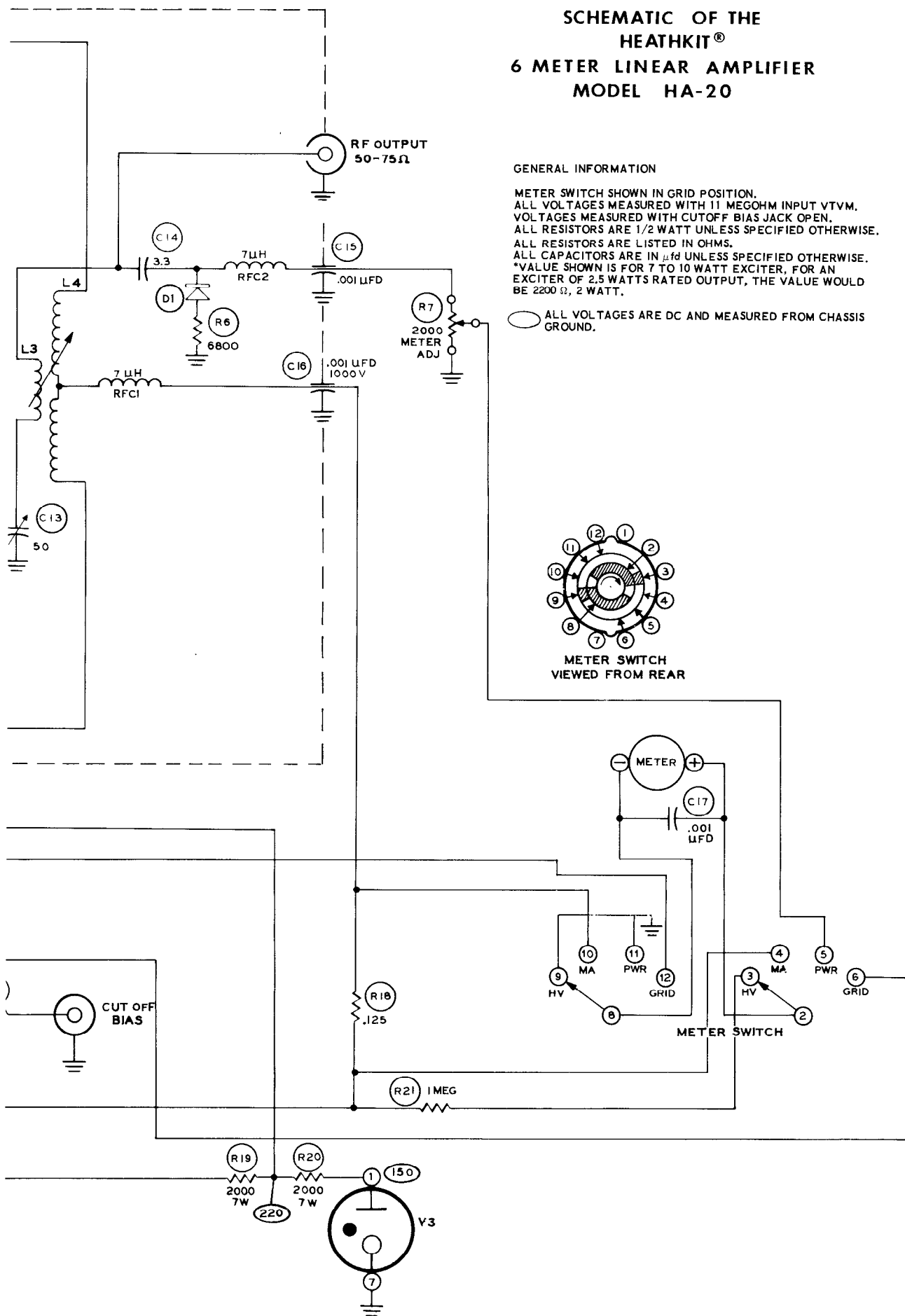



■ H E A T H C O M P A N Y

B E N T O N H A R B O R , M I C H I G A N Y U K O N 3 - 3 9 6 1

November 27, 1962

Dear Customer:

Please make the following changes in your HA-20 Manual before beginning assembly.

Page 19 - Change the first step in the right-hand column to read as follows:

- () Twist the yellow and the yellow-green leads together. Connect the yellow lead to lug 2 (S-1) and the yellow-green lead to lug 1 (S-1) of terminal strip AH. These are spare filament leads.

Change the second step in the right-hand column to read as follows:

- () Connect either wire of the twisted pair of stranded wires near terminal strip B to lug 1 (S-1) and the other to lug 2 (S-1) of switch AB.

Page 30 - Use the Pictorial 14 supplied with this letter, in place of Pictorial 14 in the manual.

Page 31 - Change the sixth step in the left-hand column to read as follows:

- () L1. Position the 6 meter link coupling coil as shown. Solder the short lead of the coil to lug 1 of coax connector AP, and the long lead to lug 1 of terminal strip AN (S-2).

Page 32 - Change the fourth step in the left-hand column to read as follows:

- () Connect one of the pilot lamp leads to lug 3 (S-4) and the other lead to lug 4 (NS) of terminal strip K.

Change the paragraph at the bottom of the left-hand column to read as follows:

This completes the wiring of your Linear Amplifier. Check all wiring and soldering. All connections should be soldered except feedthrough capacitors AR and BM. Shake out any wire clippings or solder splashes.

Page 33 - Under PRELIMINARY CHECK, refer to the Pictorial 14 supplied with this letter, in place of Pictorial 14 in the Manual.

Page 34 - Delete the last step in the left-hand column.

Add the following information after the last step in the right-hand column:

() Turn the Amplifier off.

CAUTION: ALLOW TIME FOR HIGH VOLTAGE TO BLEED OFF BEFORE ATTEMPTING THE FOLLOWING STEPS.

Delete the NOTE at the bottom of the right-hand column.

Page 35 - Add the following NOTE directly under the title CW:

NOTE: Never operate the Amplifier unless a 50 to 75 Ω dummy load or antenna is connected to the OUTPUT jack.

Thank you,

HEATH COMPANY

HA-20
11/27/62

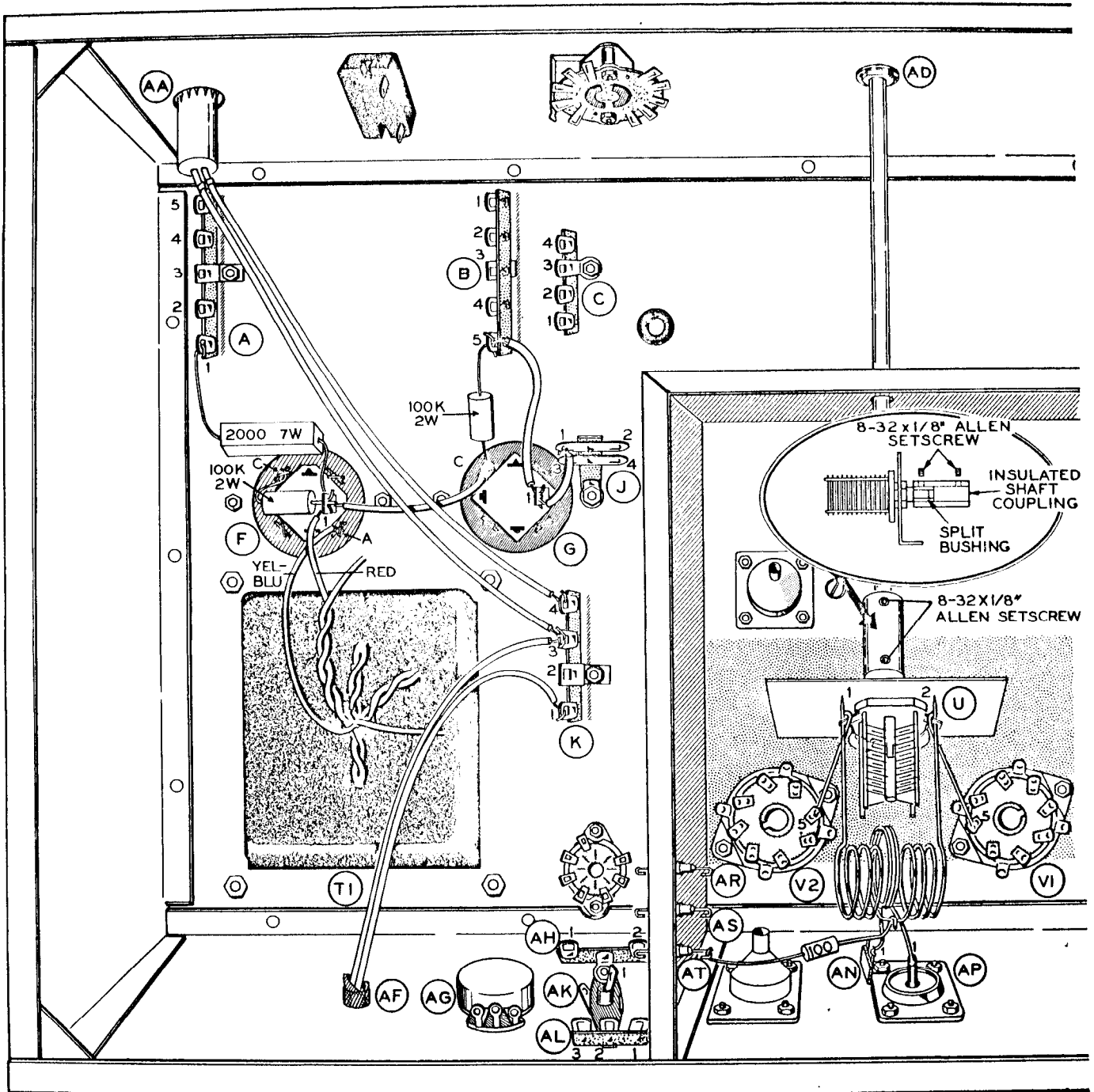

Pictorial 14