

HEATHKIT[®] MANUAL

for the

**SOLID-STATE
DIP METER**
Model HD-1250

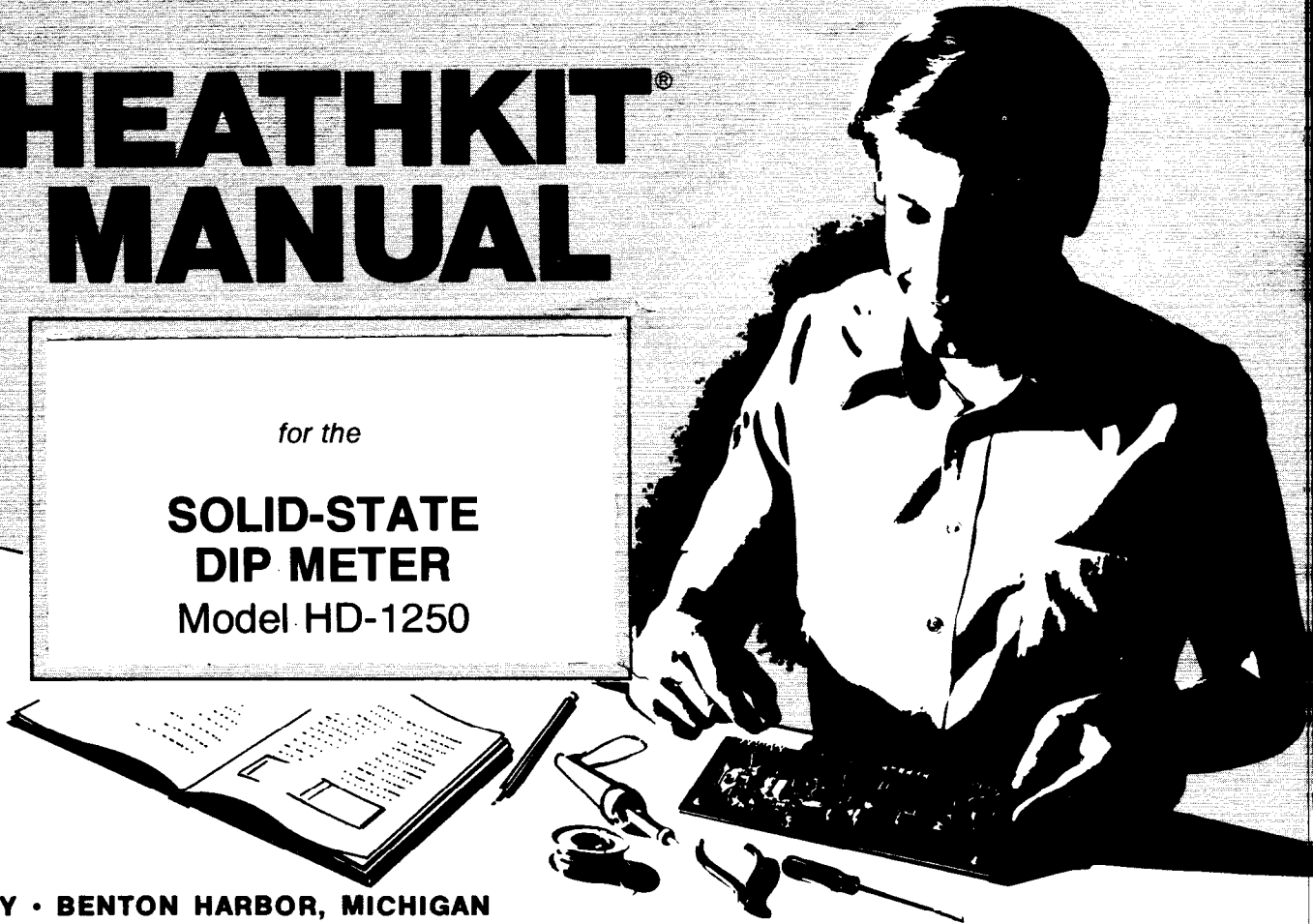

HEATH COMPANY • BENTON HARBOR, MICHIGAN



TABLE OF CONTENTS

Introduction	2	Final Assembly	39
Parts List	3	Operation	42
Step-by-Step Assembly		Applications	47
Assembly Notes	13	In Case of Difficulty	58
Detector Circuit Board	14	Troubleshooting Chart	60
Oscillator Circuit Board	17	Specifications	62
Chassis	20	Circuit Description	63
Top Panel Assembly	26	Circuit Board X-Ray Views	64
Initial Test	29	Circuit Board Voltage Charts	65
Oscillator Installation	31	Diode-Transistor Identification Chart	66
Side Panel Assembly	34	Schematic . . (fold-out from page)	67
Final Adjustment	35	Warranty	Inside front cover
Trimmer Adjustment	36	Customer Service	Inside rear cover
Calibration	37		

INTRODUCTION

Your Heathkit Solid-State Dip Meter can be used to determine the approximate resonant or operating frequency of either energized or de-energized circuits in the frequency range between 1.6 and 250 MHz. In the oscillation or injection mode, you may use the Dip Meter to determine the resonant frequency of tuned circuits or as a variable signal source to align receivers. In the absorption mode, it will locate sources and frequencies of RF energy. It is also valuable for locating sources of parasitic oscillations and harmonics.

You can select any of the seven frequency ranges by using the appropriate plug-in coil. Its size and battery-powered circuit make the Dip Meter completely portable. Two circuit boards are used to provide compactness and ease of assembly. Two transistors and two hot-carrier diodes are used in the all-solid-state circuit. To help in both transportation and storage, a molded carrying case is provided for your convenience.

Refer to the "Kit Builders Guide" for information on tools, wiring, soldering, resistors, and capacitors.

PARTS LIST

Check each part against the following list. Make a check (✓) in the space provided as you identify each part. Any part that is packed in an individual envelope with the part number on it should be placed back in the envelope after you identify it until it is called for in a step. Do not discard any packing materials until all parts are accounted for.

Each circuit part in this kit has its own "Circuit Component Number" (R1, C11, D21, etc.). This is a specific number for only that one part. The purpose of these numbers is to help you easily identify the same part in each section of the Manual. These numbers will appear:

- In the Parts List.
- At the beginning of each step where a component is installed.
- In some illustrations.
- In the sections at the rear of the Manual.

To order a replacement part, always include the PART NUMBER. Use the Parts Order Form furnished with the kit. If one is not available, see "Replacement Parts" inside the rear cover of this Manual. Your Warranty is located inside the front cover. For pricing information, refer to the separate "Heath Parts Price List."

QTY.	DESCRIPTION	PART No.	CIRCUIT Component No.
------	-------------	-------------	-----------------------------

RESISTORS, 1/4-Watt, 5% Tolerance

NOTE: 5% tolerance resistors have a fourth color band of gold.

()	1	27 Ω (red-violet-black)	1-96-12	R12
()	2	330 Ω (orange-orange-brown)	1-92-12	R24, R25
()	1	1500 Ω (brown-green-red)	1-71-12	R14

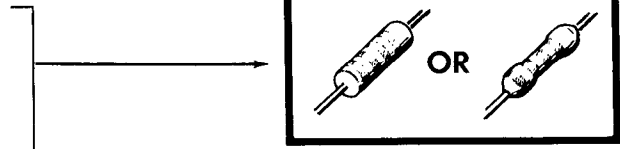

QTY.	DESCRIPTION	PART No.	CIRCUIT Component No.
Resistors (cont'd.)			
() 2	2200 Ω (red-red red)	1-72-12	R26, R27
() 1	4700 Ω (yellow-violet-red)	1-76-12	R11
() 1	10 k Ω (brown-black-orange)	1-80-12	R15
() 2	27 k Ω (red-violet-orange)	1-81-12	R16, R21
() 1	47 k Ω (yellow-violet-orange)	1-83-12	R22
() 2	100 k Ω (brown-black-yellow)	1-84-12	R13, R23

CAPACITORS

() 2	47 pF mica	20-101	C11, C12
() 1	5 pF disc	21-157	C13
() 4	.001 μ F disc	21-140	C15, C23, C24 C25
() 1	.01 μ F disc	21-176	C26
() 3	.01 μ F ceramic (small) NOTE: May be marked "103."	21-185	C14, C22, C27
() 1	Tuning capacitor	26-146	C21A, C21B, C21C

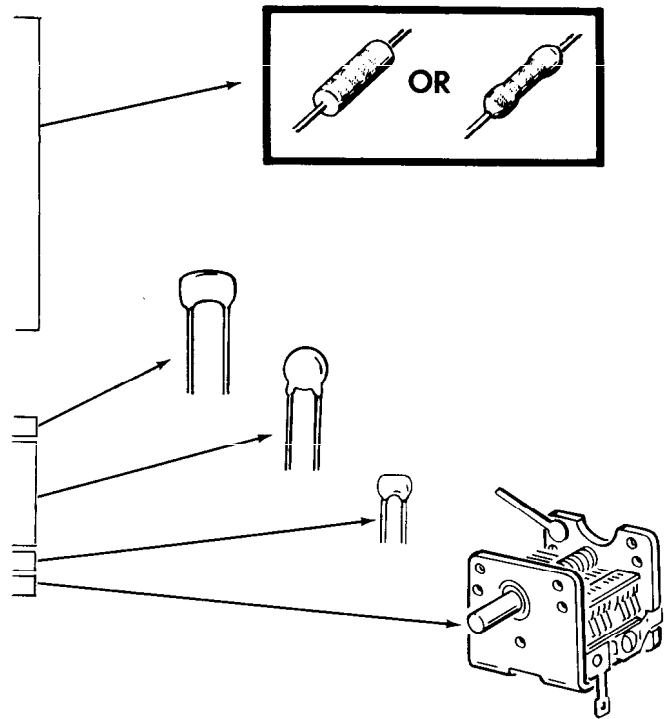



QTY.	DESCRIPTION	PART No.	CIRCUIT Component No.
COILS			
() 1	1.6-3.4 MHz coil (red)	40-1689	L1
() 1	3.2-6.6 MHz coil (orange)	40-1690	L2
() 1	6.3-13 MHz coil (yellow)	40-1691	L3
() 1	12.5-26 MHz coil (green)	40-1692	L4
() 1	25-51 MHz coil (blue)	40-1693	L5
() 1	48-100 MHz coil (violet)	40-1694	L6
() 1	100-250 MHz coil (brown)	40-1695	L7

DIODES—TRANSISTORS

() 2	FH1100 diode	56-87	D21, D22
-------	--------------	-------	----------

NOTE: Transistors may be marked for identification in any of the following four ways:

1. Part number.
2. Type number.
3. Part number and type number.
4. Part number with a type number other than the one listed.

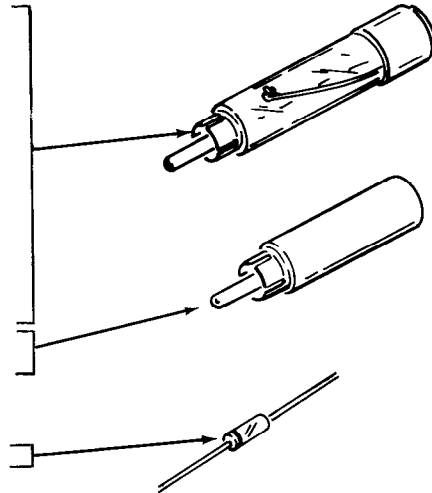



QTY.	DESCRIPTION	PART No.	CIRCUIT Component No.
Transistors (cont'd.)			
() 1	40673	417-274	Q21
() 1	MRF502	417-290	Q11
METAL PARTS			
() 1	Chassis	200-691	
() 1	Right side panel	203-1608-2	
() 1	Left side panel	203-1609-2	
() 1	Top panel	203-1621-2	

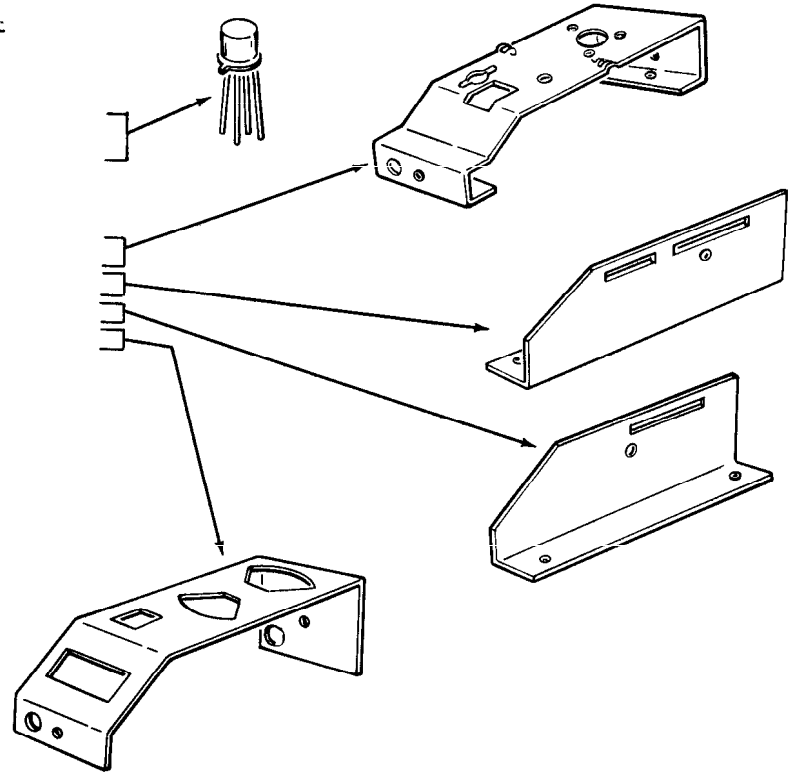



QTY.	DESCRIPTION	PART No.	CIRCUIT Component No.
------	-------------	----------	-----------------------

WIRE-BRAID

()	2-1/2" Bare wire	340-2	
()	3" Orange wire	344-93	
()	3" Yellow wire	344-94	
()	3" Green wire	344-95	
()	5" Blue wire	344-96	
()	6" Braid	345-1	

HARDWARE

()	6	6-32 x 3/16" screw	250-138
()	8	6-32 x 3/8" black screw	250-381
()	1	#6 self-tapping screw	250-106
()	1	8-32 x 1/4" set screw	250-43
()	2	6-32 nut	252-3
()	4	Spring nut	252-22
()	2	Control nut	252-39
()	2	#6 lockwasher	254-25

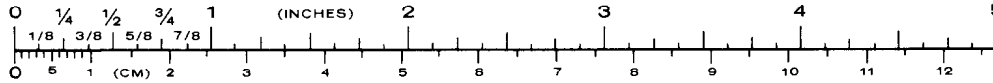
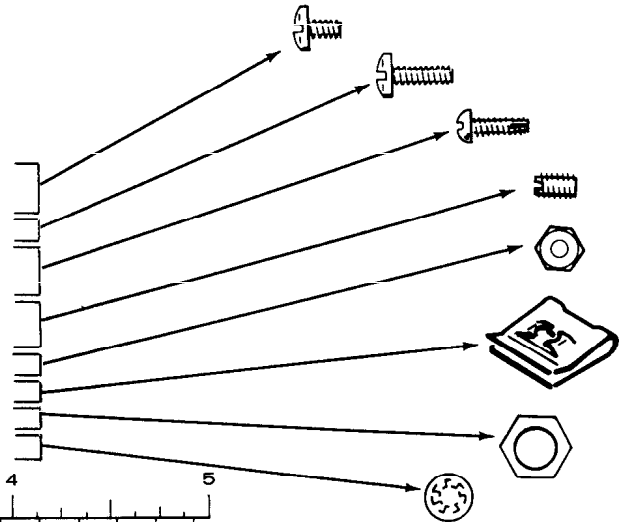

QTY.	DESCRIPTION	PART No.	CIRCUIT Component No.
------	-------------	----------	-----------------------

Hardware (cont'd.)

()	3 #6 flat washer	253-127	
()	1 Fiber washer	253-62	
()	1 Control solder lug	259-12	

PLASTIC PARTS

()	4 2" foam gasket (1 extra)	73-64	
()	1 5-3/4" x 7-3/8" foam pad	75-709	
()	1 5" thin foam tape	73-92	
()	2 Shoulder washer	75-18	
()	1 1-7/8" x 5-1/2" fiber insulator	75-103	
()	4 Foot	261-29	
()	1 Hairline grid	414-32	
()	1 Pushbutton knob	462-353	
()	1 Small round knob	462-395	
()	1 Large round knob	462-256	

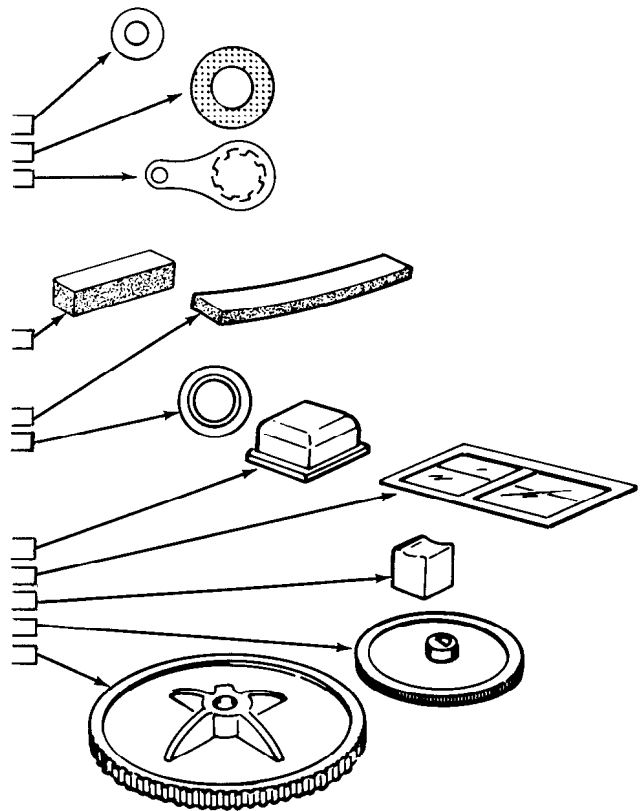

QTY.	DESCRIPTION	PART No.	CIRCUIT Component No.
------	-------------	----------	-----------------------

MISCELLANEOUS

()	1	100 k Ω control	10-125	R1
()	1	Pushbutton switch	64-85	S21
()	1	Detector circuit board	85-1712-1	
()	1	Oscillator circuit board	85-1464-1	
()	1	Carrying case	95-77	

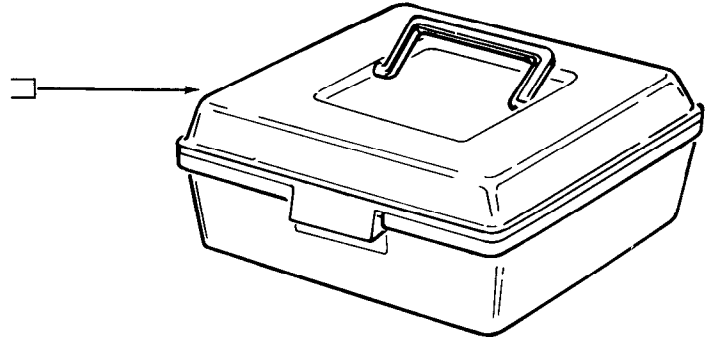
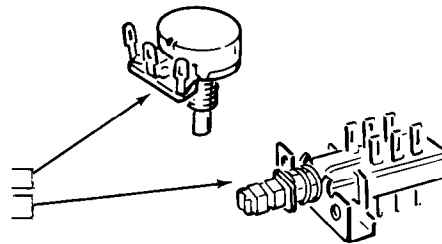

QTY.	DESCRIPTION	PART No.	CIRCUIT Component No.
------	-------------	----------	-----------------------

Miscellaneous (cont'd.)

()	1	Meter	407-705
()	1	Battery connector	432-798

()	1	Coil socket	434-107	J1
-----	---	-------------	---------	----

()	1	Phone jack	436-16	J2
()	1	Phone plug	438-26	
()	1	Ferrite bead	475-10	FB
()	1	Nut starter	490-5	

()		Solder		
-----	--	--------	--	--

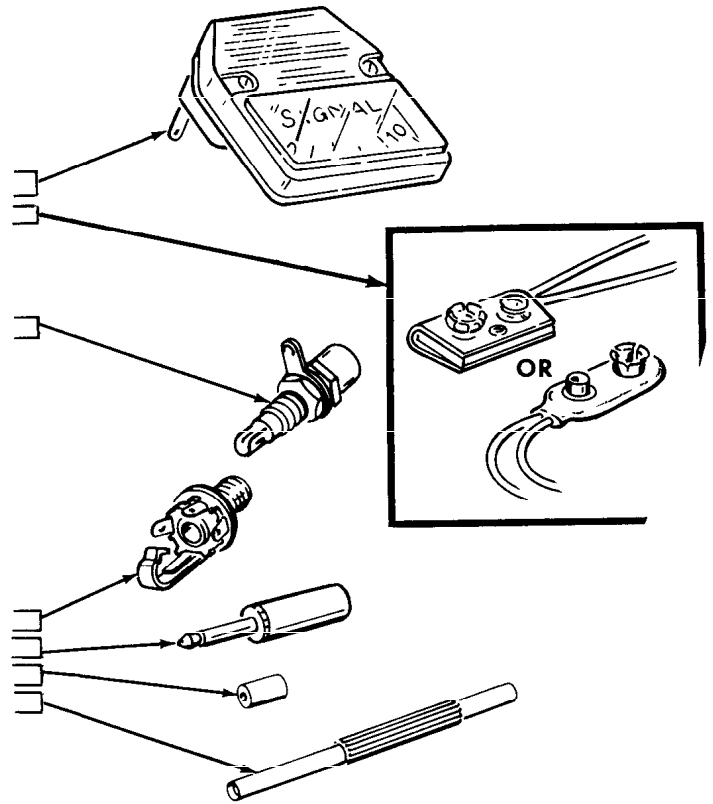



QTY.	DESCRIPTION	PART No.	CIRCUIT Component No.
------	-------------	----------	-----------------------

PRINTED MATERIAL

NOTE: Be sure you refer to the numbers on the blue and white label in any communications you may have about this kit with Heath Company. You may wish to copy the model and series numbers from the label supplied in this sample for future convenience.

- () 1 Blue and white label 391-34
- () 1 Dial label 390-1067
- () 1 "Heathkit" label 390-1069
- () 1 Parts Order Form 597-260
- () 1 Kit Builders Guide 597-308
- () 1 Manual (See front cover for part number.)

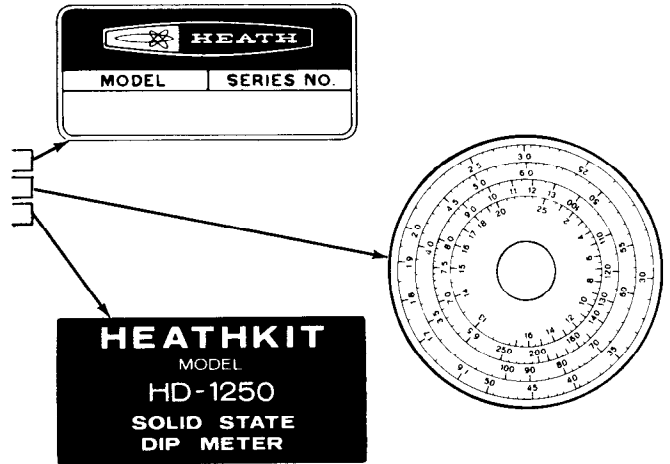

BATTERY

The following battery should be purchased at this time for use in your kit:

One 9-volt transistor battery, NEDA #1604.

Representative manufacturers and their type numbers are:

- Eveready #216
- Mallory #M1604
- Mallory #TR-146X (long life)
- Burgess #2V6
- RCA #VS323
- Hallesens #410
- Varta #438

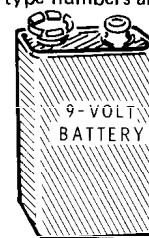

STEP-BY-STEP ASSEMBLY

ASSEMBLY NOTES

1. Before you start to assemble this kit, review the wiring, and soldering information in the "Kit Builders Guide." Also be sure to read each step all the way through before performing that step.
2. Due to the small foil area around some circuit board holes and the small areas between foils, you must use the utmost care to prevent solder bridges between adjacent foil areas. Use only a minimum amount of solder and do not heat components excessively with the soldering iron. It is also very important that you keep your soldering iron tip clean and well tinned. Diodes, transistors, etc., can be damaged if subjected to an excessive amount of heat.
3. Resistors will be called out by their resistance value in Ω or $k\Omega$ (kilohms) and color code.
4. Capacitors will be called out by their capacitance value (in pF or μF) and type (disc, mica, or ceramic).
5. Because the oscillator circuit board is small and has a tendency to move when being soldered, it is a good idea to hold it in some manner. A simple jig made up of a small board and a pincher clothespin, as shown in Figure A, works very well for this purpose. A small vise can also be used.

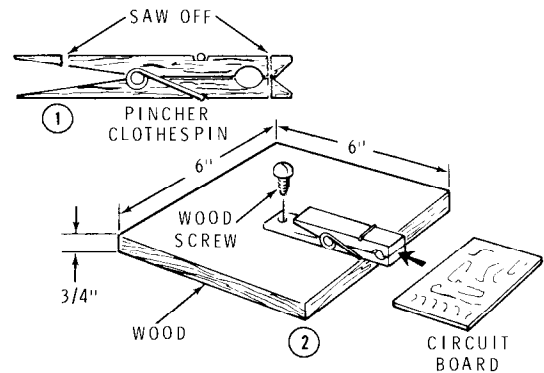

Figure A

SAFETY WARNING: Avoid eye injury when you cut off excess leads. Hold the leads so they cannot fly toward your eyes.

START ▾

Position the detector circuit board as shown in the Pictorial. Then proceed with the following steps. As you install each component in this column, solder its leads to the foil and cut off the excess lead lengths.

NOTE: When you install diodes, as in the following steps, be sure you position the banded end of each diode as it is shown on the circuit board.

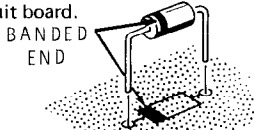

() D22. FH1100 diode (#56-87).

() D21. FH1100 diode (#56-87). Save one cutoff diode lead for use in the following step.

() Ferrite bead. Use a 1" cutoff diode lead.

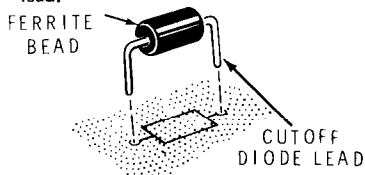

DETECTOR CIRCUIT BOARD

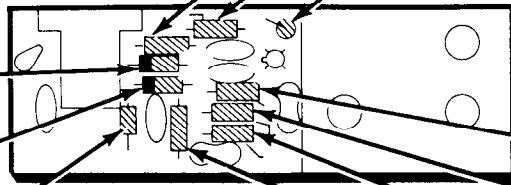

PICTORIAL 1-1

CONTINUE ▾

- () R27. 2200 Ω (red-red-red).
- () R25. 330 Ω (orange-orange-brown).
- () R23. 100 kΩ (brown-black-yellow).

Form the leads as shown. Then mount the resistor vertically.

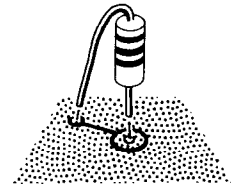

- () R24. 330 Ω (orange-orange-brown).
- () R21. 27 kΩ (red-violet-orange).
- () R22. 47 kΩ (yellow-violet-orange).
- () R26. 2200 Ω (red-red-red).

() Solder the leads to the foil and cut off the excess lead lengths.



START ◀

NOTE: Before you install disc capacitors, use long-nose pliers to remove the excess insulation from the capacitor leads.

**REMOVE COATING
EVEN WITH BOTTOM
OF CAPACITOR BODY**

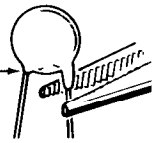

- () C24. .001 μ F disc.
- () C23. .001 μ F disc.
- () C22. .01 μ F (103) ceramic. Do not use the disc capacitor here. Tip the top of this capacitor toward the nearby resistors.
- () C25. .001 μ F disc.
- () C26. .01 μ F disc.
- () C27. .01 μ F (103) ceramic.
- () Solder the leads to the foil and cut off the excess lead lengths.

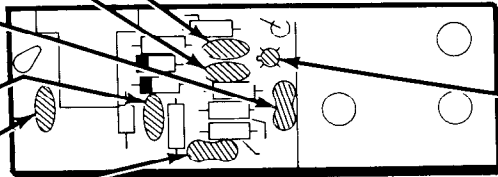

PICTORIAL 1-2

CONTINUE ▶

NOTE: In the following step, line up the locating tab on the transistor with the locating tab of the outline on the circuit board and insert the leads into the correct holes as shown. Solder the transistor leads to the foil and cut off the excess lead lengths. If there is a shorting spring on the transistor leads, remove and discard the spring.

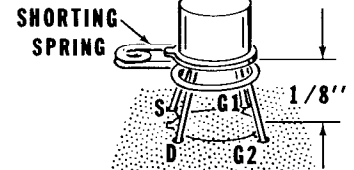

NOTE: Be sure to mount this transistor just 1/8" above the top of the circuit board.

- () Q21. 40673 transistor (#417-274).



START ▾

() S21. Pushbutton switch. Be sure to push the switch firmly, all the way down onto the circuit board. Then solder its six lugs to the foil.

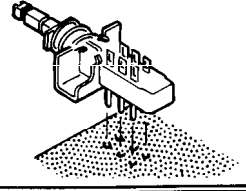

() C21A, C21B. Tuning capacitor. Mount the capacitor to the circuit board with three 6-32 x 3/16" screws and three #6 flat washers as shown below. Be sure to place the flat washers between the capacitor and the circuit board.

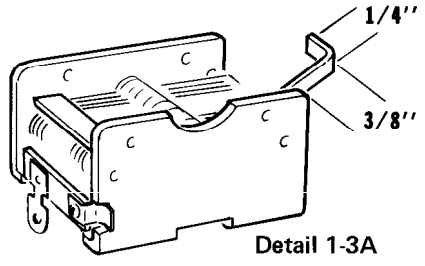
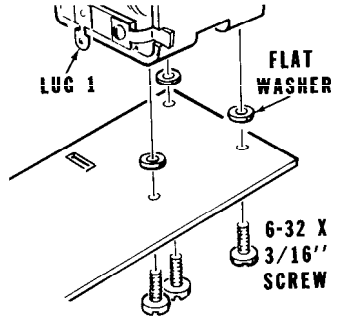

Detail 1-3A

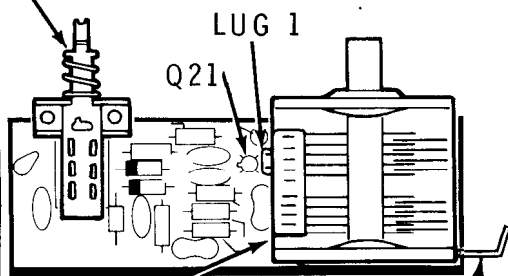

PICTORIAL 1-3

CUT GROUND TERMINAL TO 5/8"

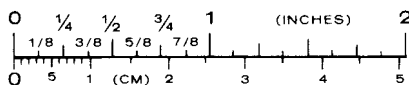

CONTINUE ▾

() Cut the ground lug to 5/8" from the corner of the tuning capacitor frame.

() Refer to Detail 1-3A and form the ground lug as shown.

CIRCUIT BOARD CHECKOUT

Carefully inspect the circuit board for the following conditions.

- () Unsoldered connections. NOTE: Do not solder tuning capacitor lug 1.
- () "Cold" solder connections.
- () Solder bridges between foil patterns.
- () Protruding leads which could touch together.
- () Transistor for the proper installation.
- () Diodes for the correct position of the banded end.
- () Be sure the case of transistor Q21 does not touch tuning capacitor lug 1.

NOTE: At this time, there are two small unused holes in the circuit board.

Set the circuit board aside temporarily.

OSCILLATOR CIRCUIT BOARD

START ▶

Position the oscillator circuit board as shown. Then proceed with the following steps.

- () Cut one lead of a 47 pF mica capacitor to 1/4" and cut the other lead to 3/4". Bend the longer lead straight out, and the short lead toward the side as shown.



- () In the same manner, prepare another 47 pF mica capacitor. Bend the short lead in the opposite direction to the one in the previous step.

NOTE: In the following steps, push the short capacitor lead into the circuit board hole. Position each mica capacitor flat on the circuit board as shown. Then, solder each capacitor to the foil as you mount it and cut off the excess lead length.

- () C12. 47 pF mica.
- () C11. 47 pF mica.

LONG LEAD

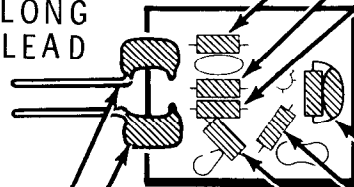

PICTORIAL 2-1

FOR GOOD SOLDER CONNECTIONS, YOU MUST **KEEP THE SOLDERING IRON TIP CLEAN.**

WIPE IT OFTEN WITH A DAMP SPONGE OR CLOTH.



CONTINUE ◀

- () R11. 4700 Ω (yellow-violet-red).
- () R13. 100 kΩ (brown-black-yellow).
- () R16. 27 kΩ (red-violet-orange).

- () Remove the excess coating from the leads of a .001 μF disc capacitor. Then wrap the leads of the capacitor around the leads of a 27 Ω (red-violet-black) resistor as shown. Solder the leads as shown and cut off the excess resistor leads.

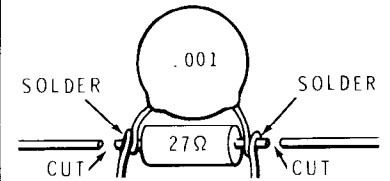

- () R12-C15. Mount the prepared resistor-capacitor assembly.
- () R14. 1500 Ω (brown-green-red).
- () R15. 10 kΩ (brown-black-orange).
- () Solder the leads to the foil and cut off the excess lead lengths.

START ↙

NOTE: In the following steps, line up the locating tab on the transistor with the locating tab of the outline on the circuit board and insert the leads into the correct holes as shown. Solder the transistor leads to the foil and cut off the excess lead lengths. NOTE: The 1/8" transistor height above the circuit board is critical.

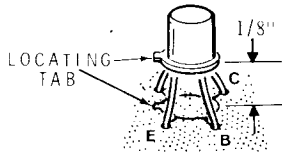

() Q11. MRF502 transistor (#417-290).

NOTE: Check to be sure no part of transistor Q11 is touching the resistor-capacitor assembly.

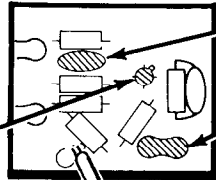

PICTORIAL 2-2

5" BLU

CONTINUE ↘

NOTE: Before you install the following disc capacitor, use long-nose pliers to remove the excess insulation from the capacitor leads.

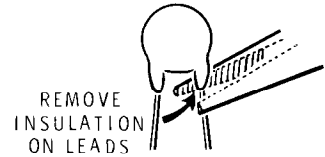

() C13. 5 pF disc.

() C14. .01 μ F (103) ceramic. Save both cutoff capacitor leads for use later.

() Solder the leads to the foil and cut off the excess lead lengths.

NOTE: To prepare a wire, as in the following step, first cut it to the indicated length and then remove 1/4" of insulation from each end. Tightly twist each wire end and apply a small amount of solder to hold the small strands together.

() Prepare a 5" blue wire.

() 5" blue wire at C. Solder the wire to the foil and cut off the excess wire length. The free end will be connected later.

**START** ▾

Turn the oscillator circuit board foil-side-up and position it as shown.

- () Apply a thin layer of solder to the two corners of the circuit board as shown.
- () Cut two 1" lengths of wire braid. Apply a small amount of solder to both ends of both braid lengths.
- () Position one 1" length of braid 1/8" onto corner A of the circuit board. Heat the foil and the braid until the solder melts. Remove the heat from the connection. NOTE: Hold the braid with pliers to avoid burning your fingers.
- () In the same manner, mount and position the other 1" wire braid at corner B on the board. Be sure you do not make a solder bridge to other foils.

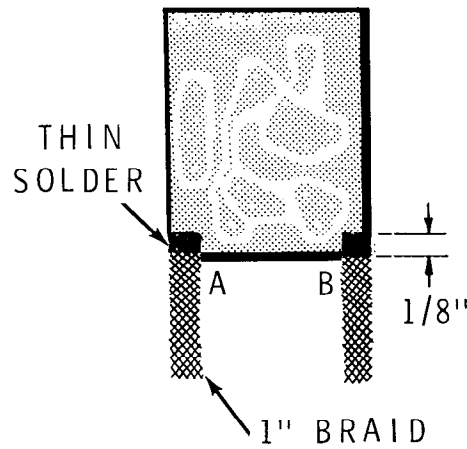

PICTORIAL 2-3

CONTINUE ▾

CIRCUIT BOARD CHECKOUT

Carefully inspect the circuit board for the following conditions:

- () Unsoldered connections
- () "Cold" solder connections.
- () Solder bridges between foil patterns.
- () Protruding leads which could touch together.
- () Transistor for the proper type and installation.

FINISH

Set the circuit board aside temporarily.

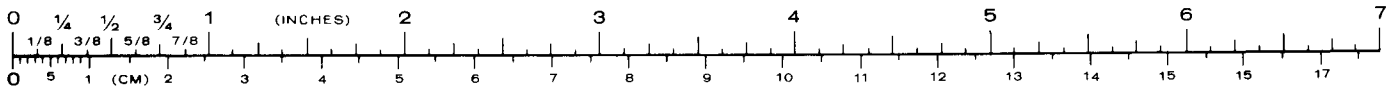

CHASSIS

Refer to Pictorial 3-1 (fold-out from Page 21) and Detail 3-1A for the following steps.

- () Locate the #6 self-tapping screw.
- () Position the chassis as shown. Then turn the self-tapping screw straight into the chassis sidemount at location A. Remove the screw.
- () In the same manner, tap the sidemount location on the chassis at B. Discard the self-tapping screw. Blow away any metal chassis particles.
- () Press a spring nut onto the edge of the chassis at C as shown. Be sure the flat side of the nut is on the outside of the chassis.
- () In the same manner, mount the spring nuts onto the edge of the chassis at D, E, and F.
- () Refer to Detail 3-1B (fold-out from this page) and mount the coil socket in the following manner:
 1. Remove the nut, solder lug, and flat washer from the coil socket.
 2. Place a shoulder washer onto the coil socket so the shoulder is positioned as shown.

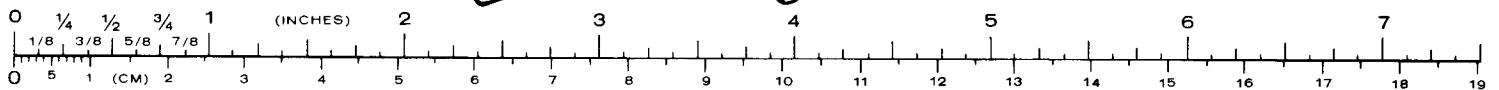
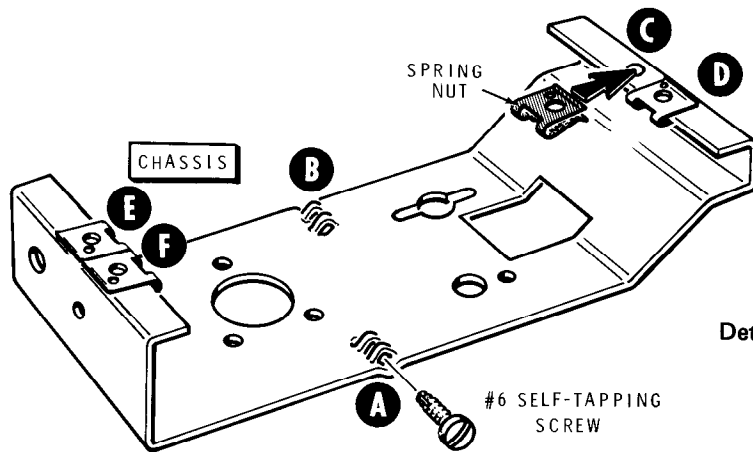

3. Mount the socket from the outside at hole G in the rear apron of the chassis.
4. Place the other shoulder washer onto the socket as shown. Then place the flat washer and the solder lug (previously removed) on the socket.
5. Place the nut back onto the coil socket. Make sure the shoulders of the plastic washers are centered in the chassis hole; then tighten the nut finger tight.
6. Position the solder lug as shown in the Pictorial; then tightly secure the nut onto the socket. NOTE: If you have a nutdriver, use it to perform this step.
7. Refer to the inset drawing on Detail 3-1B and bend the solder lug outward at a 45-degree angle to the rear apron.

NOTE: When you are instructed to prepare wires, as in the following step, cut each wire to the indicated length and remove 1/4" of insulation from each wire end. Tightly twist each wire end and apply a small amount of solder to hold the small strands together.

- () Prepare the following wires:

2-1/2" green
 2-1/2" yellow
 2-1/2" orange

In the following steps, (NS) means not to solder because other wires will be added later. "S-" with a number, such as (S-3), means to solder the connection. The number following "S" tells how many wires should be at the connection.

Refer to Detail 3-1C for the following steps.

- () Connect a 2-1/2" green wire to phone jack lug 3 (S-1).

- () Connect a 2-1/2" yellow wire to phone jack lug 2 (S-1).

- () Connect a 2-1/2" orange wire to phone jack lug 1 (S-1).

NOTE: Use care when you install the phone jack in the following step. It is important that you do not bend any of the lugs or contacts; this might cause the Dip Meter to be inoperative.

- () Mount the phone jack at chassis hole H. Position the lugs as shown in the Pictorial. Be sure that none of the lugs are shorted to the chassis. Secure the jack with a control nut.

- () Check the phone jack for screw clearance. Turn a 6-32 x 3/8" screw all the way through spring nut C and make sure the screw does not touch the jack. If necessary, loosen the control nut and rotate the jack slightly. Then retighten the nut.

- () Remove the screw from spring nut C.

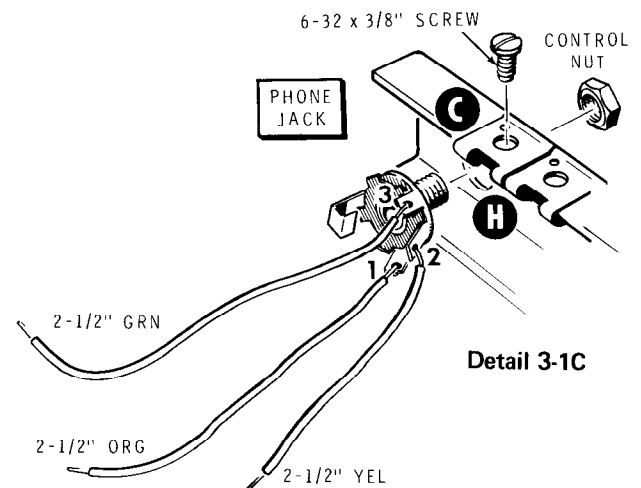

Refer to Pictorial 3-2 (fold-out from this page) for the following steps.

- () R1: Refer to Detail 3-2A and mount the 100 k Ω control at R1 on the chassis. Use a control solder lug and a control nut. Be sure to position the control solder lug as shown in the Pictorial. Secure the nut tightly. Then bend the solder lug upward slightly, away from the chassis.

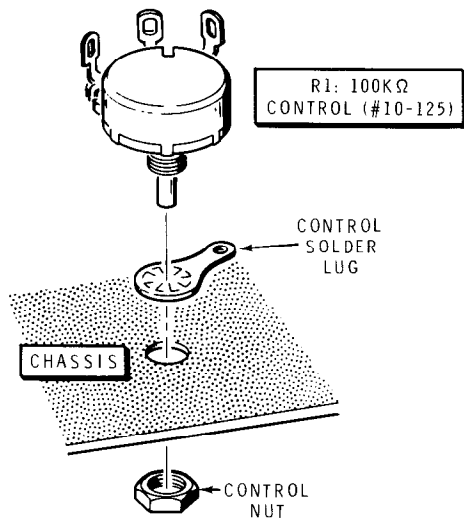

Detail 3-2A

- () Refer to Detail 3-2B and prepare a 1" length of bare wire as shown. The small loop should be approximately 1/16" in diameter. Use one of the capacitor leads you saved from the circuit board assembly steps.

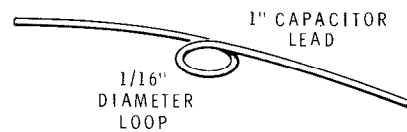

Detail 3-2B

- () Pass one end of this prepared wire into control R1 lug 3 (S-1) and the other end of the wire through the solder lug hole (S-1). Position the small loop of the wire as shown in the Pictorial.
- () Mount the detector circuit board assembly onto the chassis at K, L, and M with three 6-32 x 3/16" screws as shown in Detail 3-2C. NOTE: The screws pass through the chassis and into the tuning capacitor frame.



NOTE: When you connect and solder wires in the following steps, cut off any excess wire or lead lengths.

- () Connect the free end of the orange wire coming from lug 1 of the phone jack to detector circuit board hole A (S-1).
- () Connect the free end of the yellow wire to pushbutton switch lug 6 (NS).
- () Connect the free end of the green wire to pushbutton switch lug 5 (S-1).

- () Refer to Detail 3-2D and prepare the battery connector as shown. Save the cutoff red lead; it will be used later in the next two steps.
- () Cut a 1-1/2" length from the saved red battery connector lead. Prepare both ends by removing 1/4" insulation.
- () Connect the red battery connector lead to pushbutton switch lug 2 (S-1).
- () Connect the 1-1/2" red wire from control R1 lug 1 (S-1) to pushbutton switch lug 1 (S-1).
- () Connect the black battery connector lead to pushbutton switch lug 4 (S-1).

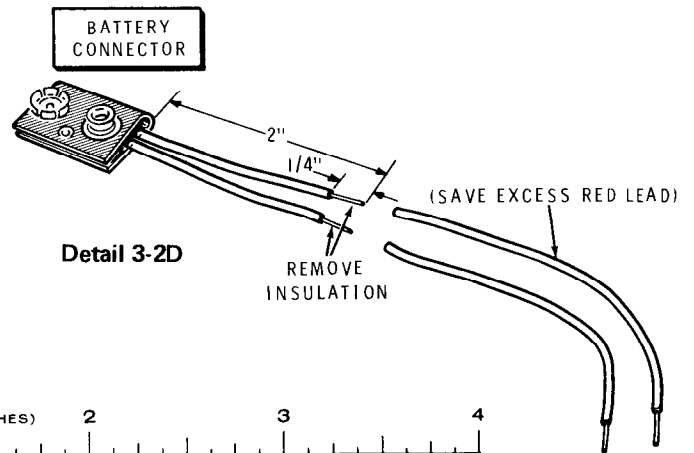
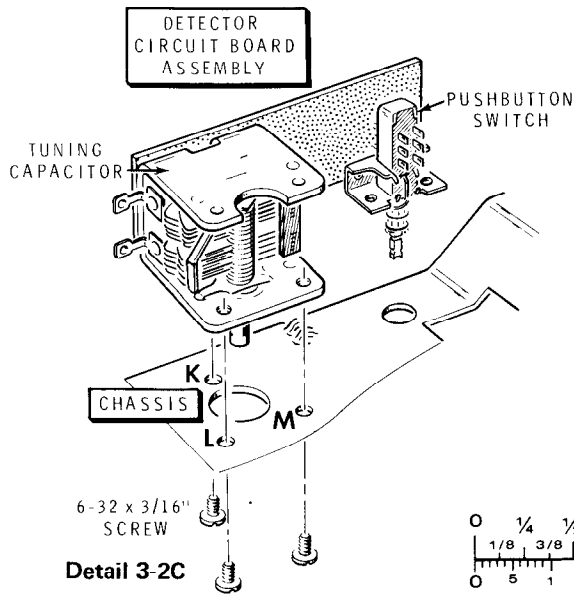

Refer to Pictorial 3-3 for the following steps.

- () Place the small round knob onto the shaft of control R1. Be sure the center hub is up, and that the flat in the knob matches the flat on the control shaft. Press the knob as far down onto the shaft as you can.

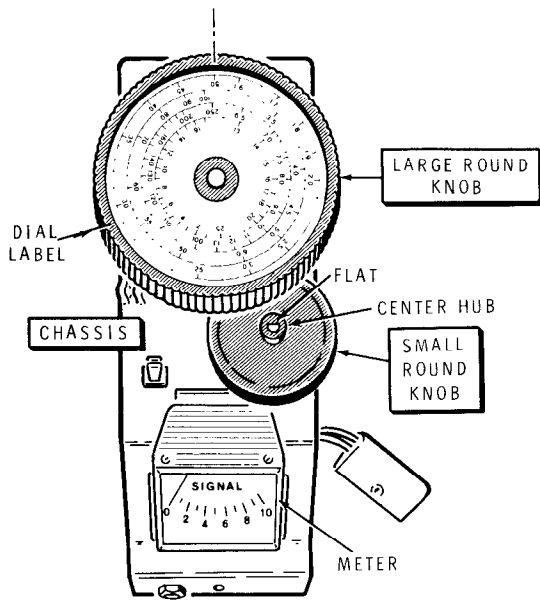

PICTORIAL 3-3

Refer to Detail 3-3A for the following steps.

- () Turn the tuning capacitor shaft clockwise until the plates are fully meshed.

- () Place the fiber washer onto the tuning capacitor shaft.

NOTE: Keep the large round knob dial surface free of grease, hand oiliness, or film.

- () Start the B-32 x 1/4" setscrew into the hub on the large round knob as shown.

- () Place the large round knob onto the tuning capacitor shaft, center hub down, as shown in the Pictorial. Position the knob on the shaft so the setscrew faces the right side of the chassis. Then tighten the setscrew.

NOTE: In the following step you will be instructed to mount the dial label on the large round knob. Carefully read the instructions and do not press the label in place until you are sure it is correctly positioned.

- () Mount the dial label on the large round knob as follows, and as shown in the Pictorial.

1. Turn the tuning capacitor shaft until the plates are fully meshed.
2. Draw a small pencil mark on the top of the chassis, at the rear of the large knob, and equally centered between the sides of the chassis.
3. Position the dial label as shown (do not remove the paper backing yet). Observe, in the blue outer edge, the "50" at one end. This 50 in the blue band is the dial index. Position the 50-index so it is directly in line with the pencil mark on top of the chassis (see Step 2, above).

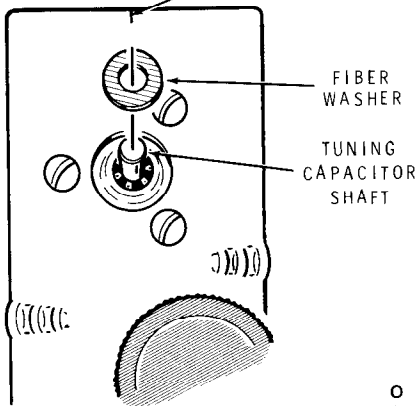
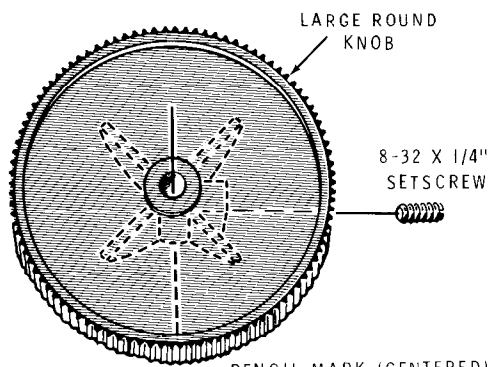

Detail 3-3A

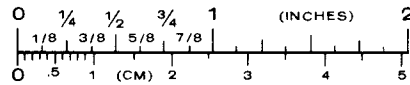

4. Carefully peel the paper backing from the dial label. Position the 50-index in line with the chassis mark and center the label over the center of the large knob. Press the label in place on the large knob, working from the center outward.

- () Cut a 1-1/2" length of thin foam tape from the 5" length supplied.
- () Refer to Detail 3-3B. Remove the paper backing from one side of the thin foam tape; then press the tape in place on the back of the meter as shown. NOTE: Do not remove the paper from the other side of the tape.
- () Remove the shorting wire from the meter lugs.
- () Place the meter down into its opening in the chassis so it is positioned as shown in the Pictorial. NOTE: Do not bend the Meter lugs.

Set the chassis assembly aside temporarily.

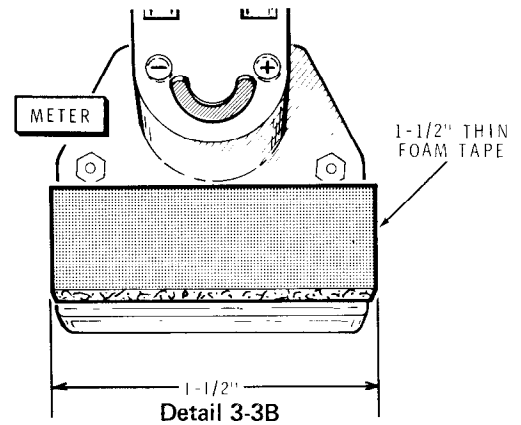

TOP PANEL ASSEMBLY

Refer to Pictorial 4-1 (fold-out from Page 27) for the following steps.

- () Remove the paper backing strips from the hairline grid and, if necessary, any protective film from the other side. Then refer to Detail 4-1A and carefully press the grid in place on the inside of the top panel as shown. Be sure the hairline is exactly centered from side to side as shown. Also, be sure none of the adhesive backing is exposed in the panel openings.
- () Carefully position the rear of the top panel over the coil socket on the rear of the chassis. Then lower the top panel downward, carefully, over the shaft of the pushbutton switch and over the top of the meter. Slightly spring the front edge of the top panel forward, and continue sliding it downward until the hole in the front is around the phone jack as shown in the Pictorial. Carefully work the meter face from side to side slightly until it fits properly into the top panel meter opening.

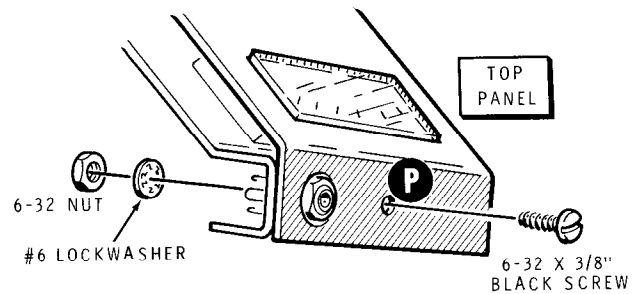

Detail 4-1B

NOTE: Use the nut starter to hold and start 6-32 nuts on screws.

- () Refer to Detail 4-1B and secure the top panel to the chassis at P with a 6-32 x 3/8" black screw, a #6 lockwasher, and a 6-32 nut.

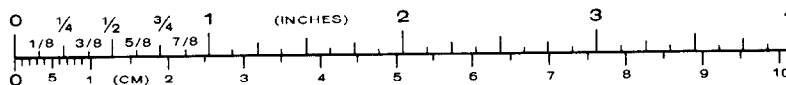

- () Refer to Detail 4-1C and prepare a 1-3/4" length of braid as shown. Use a sharp, pointed tool and form a hole in the braid 1/4" from one end. The hole must be large enough to easily pass over the threads of a 6-32 screw.

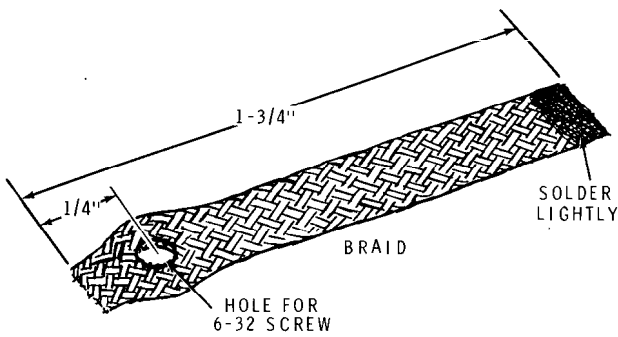

Detail 4-1C

- () Lightly solder the tip of the braid as shown in Detail 4-1C.
- () Refer to Detail 4-1D and secure the rear of the top panel to the chassis at Q with a 6-32 x 3/8" black screw, the 1-3/4" length of braid, a #6 lockwasher, and a 6-32 nut. Position the braid toward the right side of the chassis as shown; its free end will be connected later.

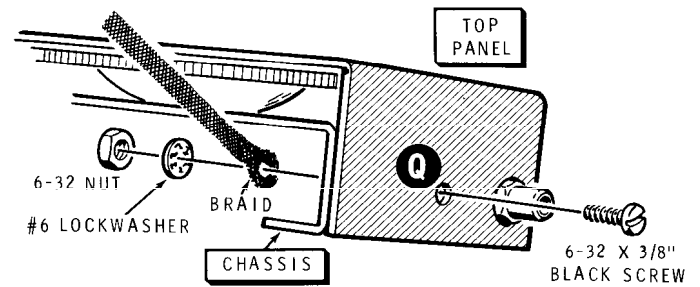

Detail 4-1D

Refer to Pictorial 4-2 for the following steps.

- () Slightly loosen the three tuning capacitor mounting screws on the detector circuit board.
- () Place the pushbutton knob onto the shaft of the pushbutton switch. Press the knob firmly until it is completely seated on the shaft.
- () Place the unit right-side up on a work surface as shown. Then, slightly move the detector circuit board either forward or rearward to center the pushbutton switch knob in its top panel opening.
- () Be sure the bottom edge of the detector circuit board is parallel to the work surface as shown. Then tighten the three capacitor mounting screws.
- () Bend the tip of tuning capacitor lug 1 close to the circuit board foil. Solder the lug to the foil; then cut the excess lug off close to the foil.
- () Recheck the switch knob and be sure it operates up and down freely.

Refer to Pictorial 4-3 for the following steps.

- () Position the chassis assembly top-side-down.
- () Cut two 3/4" lengths of bare wire.

NOTE: Do not overheat the connections in the next two steps.

- () Connect a 3/4" bare wire from tuning capacitor lug 3 (NS) to coil socket G lug 2 (S-1). Keep this wire as short as possible.
- () Connect the other 3/4" bare wire from tuning capacitor lug 2 (NS) to coil socket G lug 1 (S-1). Keep this wire as short as possible.
- () Locate the remaining capacitor lead you saved from the circuit board assembly. Cut a 3/4" length of this lead. Connect this wire from the positive (+) meter lug (S-1) to pushbutton switch lug 6 (S-2).

NOTE: In the following steps, the oscillator circuit board will be temporarily mounted outside the chassis assembly. This will enable you to perform the "Initial Tests" before the small board is mounted into the chassis behind other components.

- () Position the oscillator circuit board to the right of the chassis, foil-side toward you, so the two free capacitor leads are toward the left as shown.

- () Place the leads of the two 47 pF mica capacitors through tuning capacitor lugs 2 and 3 as shown in the Pictorial. Temporarily (lightly) solder these leads and the bare wires to the tuning capacitor lugs.
- () Apply a small amount of solder to the indicated corners of the detector circuit board. Temporarily (lightly) solder the upper and lower lengths of braid coming from the oscillator circuit board to the corners of the detector circuit board.

IMPORTANT NOTE: In the next two steps, do not bend the meter lugs; this could permanently damage the meter movement.

- () Press the small loop of wire connected to control R1 lug 3 upward until it touches the underside of the negative (–) meter lug as shown (S-1).
- () Temporarily (lightly) solder the free end of the blue wire coming from the oscillator circuit board to control R1 lug 2 (S-1).

This completes the initial assembly of your kit. Carefully inspect all connections for loose wires or unsoldered connections. Remove any wire clippings or solder splashes. Then proceed to the "Initial Test."





INITIAL TEST

Refer to Pictorial 5-1 for the following steps.

NOTE: If you have not as yet purchased a 9-volt (NEDA Type 1604) battery, you should do so at this time.

- () Be sure the pushbutton switch is in the Off (up) position.
- () Connect the 9-volt battery to the battery connector.
- () Turn the Osc Level control to minimum (fully clockwise).
- () Mount the red, 1.6–3.4 MHz coil (#40-1689) into the coil socket on the rear chassis apron.
- () Turn the Frequency dial fully clockwise.
- () Depress the pushbutton switch to turn the Dip Meter on.

NOTE: In the following step, if you do not obtain the desired meter indication, turn the Meter pushbutton switch to the Off position (up); then, refer to the "In Case of Difficulty" section of this Manual on Page 58.

- () Slowly turn the OSC LEVEL control counterclockwise to increase its sensitivity. The meter should indicate some reading, which will increase as the control is turned further counterclockwise.

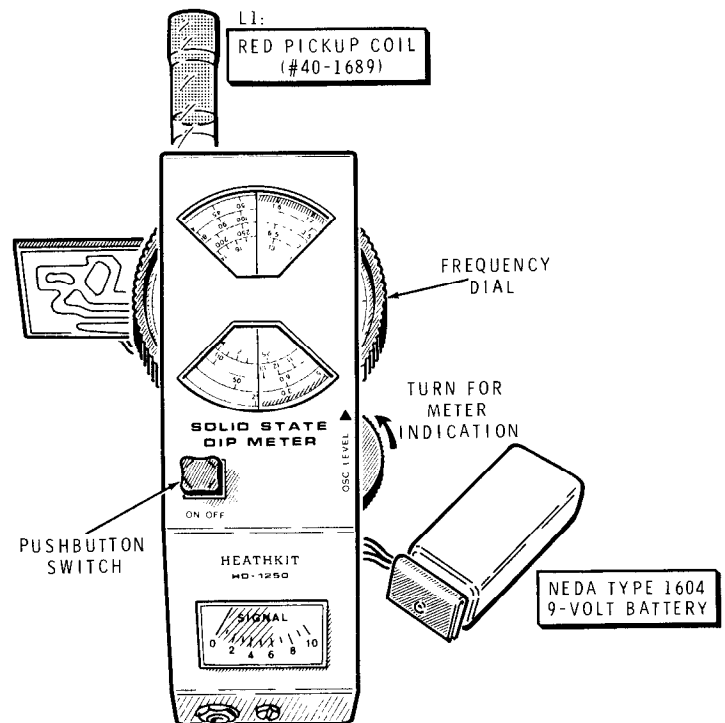

PICTORIAL 5-1

- () Turn the Dip Meter Off. Remove the coil and battery and set them aside temporarily.

NOTE: While you unsolder the connections in the next step, be careful not to bend tuning capacitor lugs 2 and 3.

- () Refer to Detail 5-1A and unsolder the following connections between the oscillator circuit board and the detector circuit board. Unsolder the two lengths of braid from the corners of the detector circuit board. Then unsolder the two 47 pF mica capacitor leads that were temporarily soldered to tuning capacitor lugs 2 and 3 and the blue wire connected to control R1 lug 2. NOTE: Do not disconnect the short bare wires from between the tuning capacitor lugs and coil socket G.

- () Heat the connections and remove the solder from tuning capacitor lugs 2 and 3 with a pointed tool or a "solder sipper."

This completes the "Initial Test;" proceed to "Oscillator Installation."

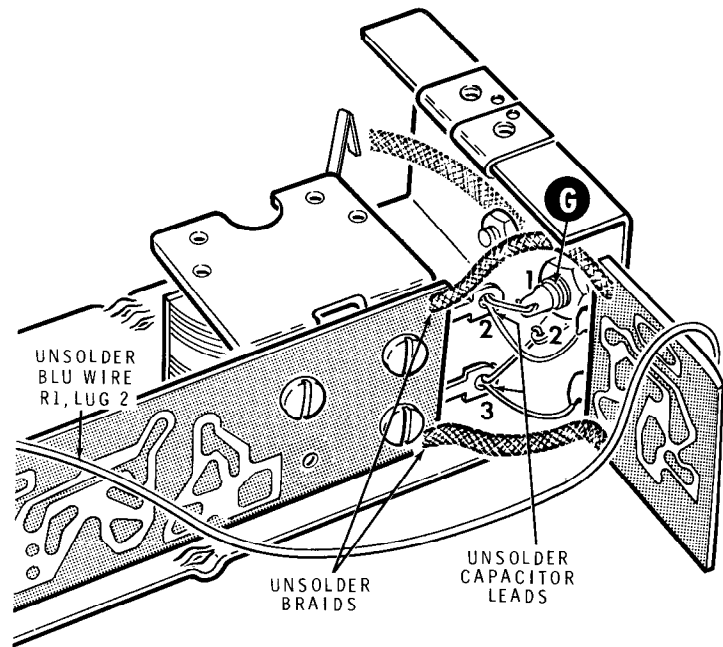

Detail 5-1A

OSCILLATOR INSTALLATION

Refer to Pictorial 6-1 (fold-out from Page 33) for the following steps.

NOTE: Be sure the free capacitor leads still extend straight out from the edge of the board, and that the 47 pF mica capacitors are flat against the circuit board.

- () Apply a small additional amount of solder to the corners on the foil side of the detector circuit board as shown in Detail 6-1A.
- () Position the chassis assembly top-side-down as shown in the Pictorial.

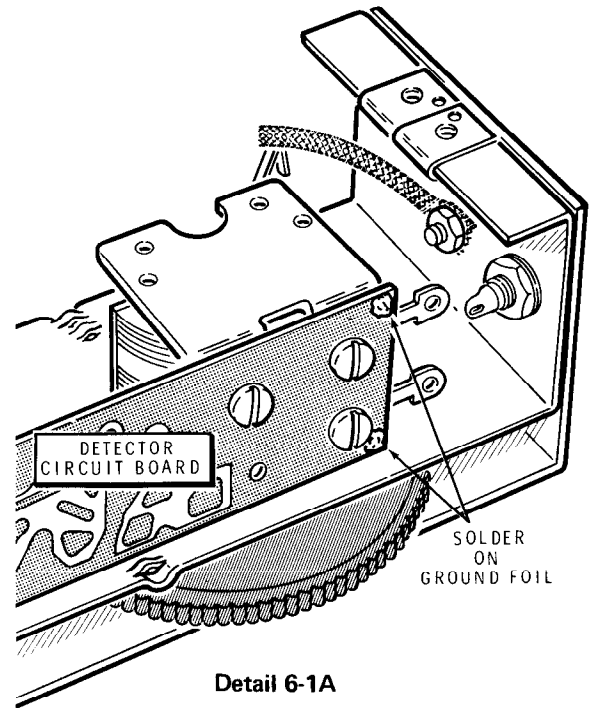

Detail 6-1A

- () Position the oscillator circuit board with the foil-side toward you, and with the two braids, the 47 pF capacitor leads, and the blue wire toward your right. Slide the oscillator circuit board into the rear of the chassis assembly, and pass the two 47 pF capacitor leads directly through tuning capacitor lugs 2 and 3 as shown. Then, press the oscillator circuit board to the right as far as you can to shorten the 47 pF capacitor leads as much as possible. Do not solder the capacitor leads. Route the blue wire under the coil socket and under the edge of the detector circuit board. NOTE: The left edge of the oscillator circuit board should be 1/2" from the edge of the chassis as shown in Pictorial and in Detail 6-1B.
- () Refer to Detail 6-1B and loop the two lengths of braid coming from the corners of the oscillator circuit board until they overlap the corners of the detector circuit board as shown. Solder each of these braid ends to the corners of the detector circuit board. Be sure neither of the braids touch the tuning capacitor lugs.
- () Position the oscillator circuit board so it is vertical and even with the edge of the chassis flange as shown in Pictorial 6-1.
- () Solder tuning capacitor lugs 2 and 3; then cut off any excess lead and wire lengths.

Refer to Detail 6-1C for the next two steps.

CAUTION: In the following step, be careful that the braid end does not "spring" and splash hot solder.

- () Loop the end of the braid secured by the back panel screw over the left end of the oscillator circuit board as shown and solder it in place. Be sure none of the braid touches any part of the circuit board other than the ground foil at the edge of the board.

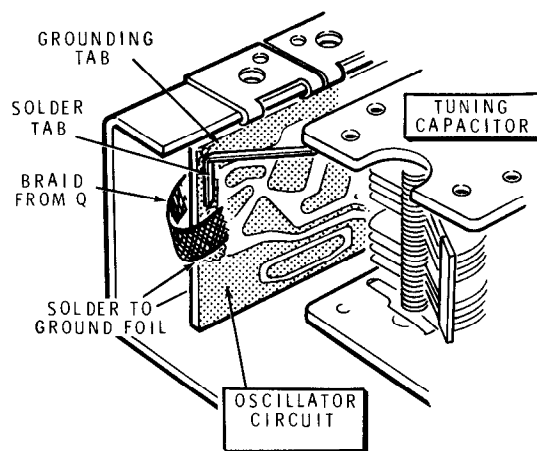

Detail 6-1C

- () Press the grounding tab coming from the corner of the tuning capacitor onto the ground foil on the upper corner of the oscillator circuit board as shown (S-1).
- () Route the blue wire from the oscillator circuit board and connect the wire end to control R1 lug 2 (S-1).

Refer to Pictorial 6-2 for the following steps.

- () Cut a 3/4" length of foam gasket.
- () Remove the paper backing from one side of the foam gasket, then press the gasket in place inside the front flange of the chassis as shown in the Pictorial.
- () Remove the paper backing from one side of a 2" length of foam gasket and press it in place just above the meter housing as shown. Be sure to tape down the three wires coming from the phone jack on the front apron.

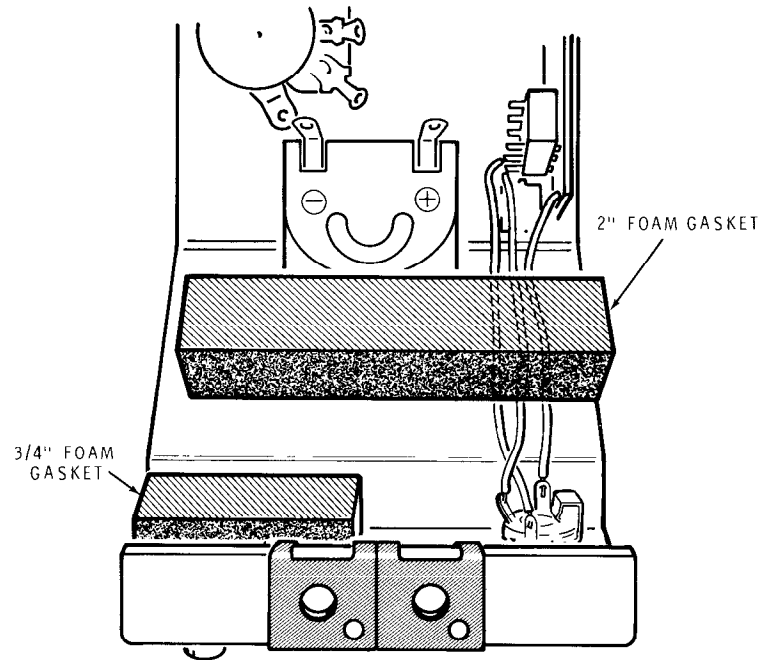

PICTORIAL 6-2

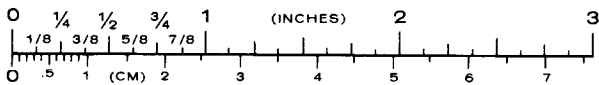

SIDE PANEL ASSEMBLY

Refer to Pictorial 6-3 for the following steps.

- () Cut a 1" x 3-1/2" piece of fiber insulator.
- () Remove the paper backing from the strip of fiber insulator and press the insulator in place on the left side panel as shown.
- () Cut a 3/4" length of foam gasket.
- () Remove the paper backing from one side of the 3/4" foam gasket and press the gasket in place on the bottom portion of the left side panel as shown.

NOTE: When you mount the side panel in the following step, be sure not to pinch the blue wire between the panel and the chassis.

- () Mount the left side panel onto the chassis assembly as follows: Secure the side of the panel with a 6-32 x 3/8" black screw. Then, turn the unit top-side down and secure the bottom of the panel with two 6-32 x 3/8" screws.
- () Be sure the pushbutton switch is OFF (out).
- () Connect the battery to the battery connector.
- () Refer to profile view Detail 6-3A and push the battery into the chassis assembly as shown. Note that the battery fits snugly between the strips of foam gasket material.
- () Rotate the tuning dial back and forth several times. If the dial rubs in the left panel dial slot, loosen the dial setscrew and move the dial up or down slightly, as necessary. Then lightly secure the screw again.

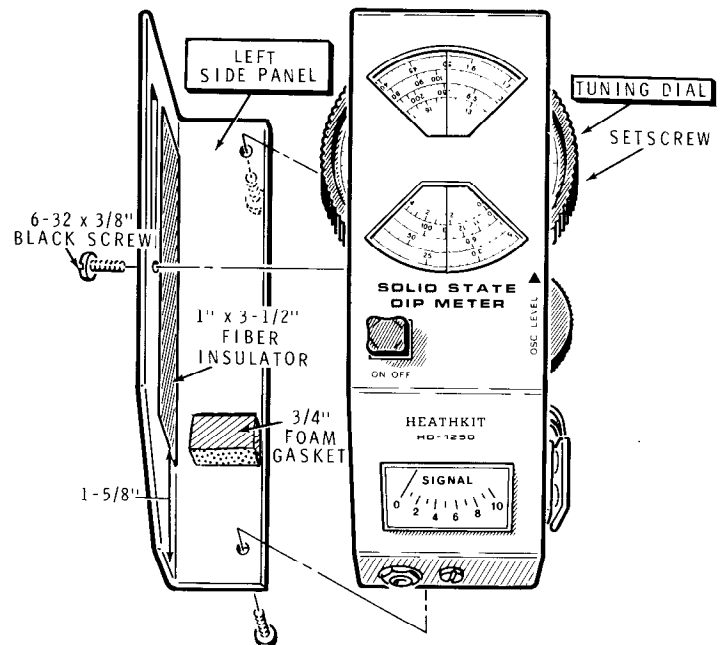

PICTORIAL 6-3

FINAL ADJUSTMENT

NOTE: In the following steps, you will make the final adjustment on the dial. Perform the steps carefully, as this will assure the accuracy of your instrument.

- () Turn the tuning dial fully clockwise.
- () Observe the "50" on the blue band at the top, outer edge of the dial. If this mark is not directly under the hairline grid, perform the following steps.
 1. Slightly loosen the setscrew in the large round knob.
 2. Turn the dial in the desired direction, until the blue band "50" is directly under the hairline.
 3. Tighten the setscrew.

Refer to Pictorial 7-1 (fold-out from Page 37) for the following steps.

- () Cut a 3/4" length of foam gasket.
- () Remove the paper backing from one side of the 3/4" length of foam gasket and press it in place on the bottom portion of the right side panel.

- () Remove the paper backing from the blue and white label and press the label in place on the bottom portion of the right side panel. NOTE: Refer to the numbers on this label in any correspondence you have with the Heath Company about your kit.

NOTE: Do not mount the right side panel at this time.

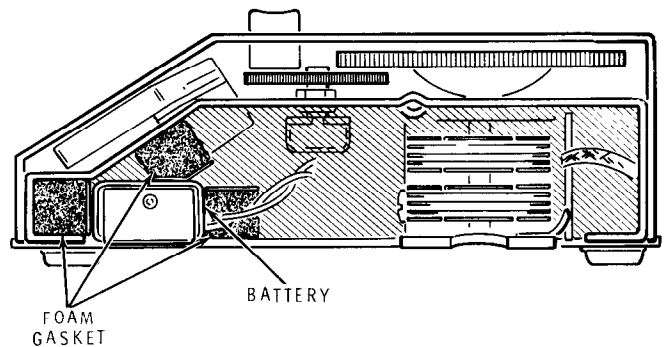

Detail 6-3A



TRIMMER ADJUSTMENT

Refer to Figure 1-1 for the following steps.

- () Plug coil L1 (red, 1.6-3.4 MHz) into the Dip Meter coil socket.
- () Turn the tuning dial fully clockwise to fully mesh the tuning capacitor.
- () Press the pushbutton in to the ON position.
- () Turn the OSC Level control until the meter just reads "10." **IMPORTANT:** Do not peg the meter (run the pointer all the way to its mechanical stop); do not change the setting of the Level control.
- () Turn the main tuning dial fully counterclockwise.
- () If the meter does not read zero, turn the trimmer screw C21C counterclockwise until the meter reads zero. **NOTE:** If the meter does not drop to zero, turn the screw counterclockwise to a point where it will just stay in the capacitor.
- () Slowly turn trimmer adjust screw C21C clockwise until there is a jump in the meter reading. Leave the trimmer screw set at this point. **NOTE:** This reading must be above "1" on the meter scale.
- () Turn the Dip Meter OFF.
- () Remove coil L1 from the Dip Meter socket.

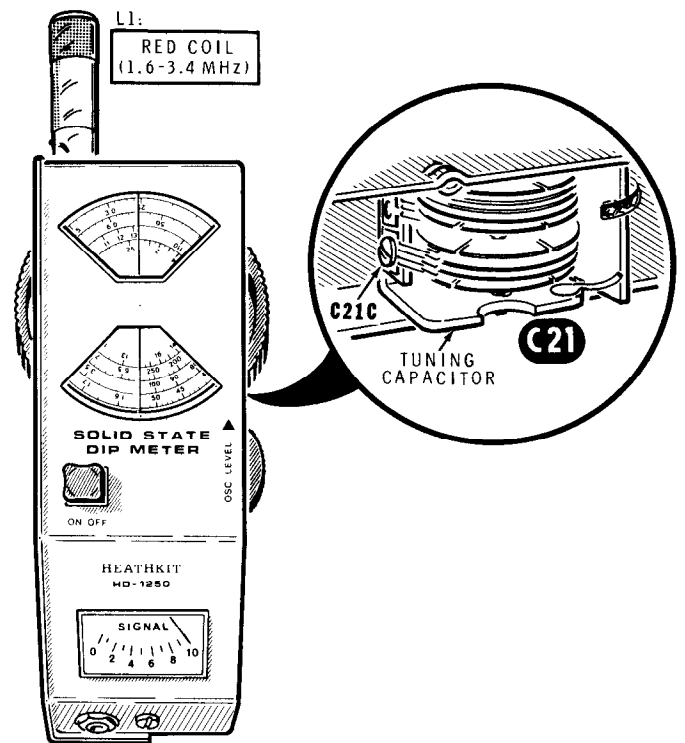

Figure 1-1

CALIBRATION

NOTE: For the purposes of slightly greater accuracy, you may wish to check your Dip Meter against an instrument or a signal of a known frequency. The following paragraphs and steps suggest two methods to do this. However, the tuning dial adjustment you did previously will have calibrated the Dip Meter for relatively close measurements.

CALIBRATION USING A KNOWN SIGNAL

Refer to Figure 1-2 for the following steps.

- () Tune a receiver to station WWV at 15.0 MHz.
- () Plug the green coil (12.5–26 MHz) into the Dip Meter coil socket.
- () Turn the Dip Meter on and tune it to approximately 15 on the green scale.
- () Turn the OSC LEVEL until you obtain a high reading.
- () Position the Meter coil close to the antenna lead-in on the receiver. Carefully move the tuning dial of the Dip Meter across the "15" on the green meter dial scale and notice how it affects the sound coming from the receiver.

NOTE: In the next step, as you tune the Dip Meter to station WWV, the desired response will be a blanking of the station as heard from the receiver.

- () Position the Meter tuning dial until WWV is entirely quieted.
- () If necessary, loosen the tuning dial setscrew, move the dial so the "15" on the green scale is directly under the hairline. Then, retighten the setscrew.

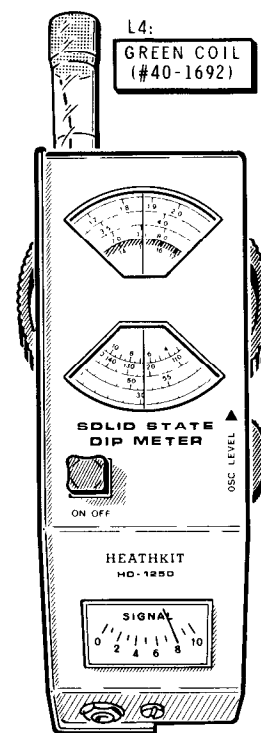

Figure 1-2



CALIBRATION USING A FREQUENCY COUNTER

- () Prepare a 12" length of wire and a length of shielded cable (not supplied) as follows:
 1. Cut a 12" length of hookup wire. Remove 1/4" of insulation from each wire end.
 2. Form a loop of several turns of the hookup wire, approximately 3/4" diameter, in the center of the wire. Leave both wire ends free.
 3. Connect one end of the wire to the inner lead of the shielded cable, and the other end of the wire to the shield lead of the shielded cable as shown in Figure 1-3.
- () Connect the shielded cable to the input of the frequency counter and turn the counter on.
- () Select any of the Dip Meter coils that are within the frequency range of the counter. Plug the coil into the coil socket on the Dip Meter.

- () Turn the Dip Meter On and turn the Level control for a 2/3 meter scale reading.

NOTE: You may wish to readjust the dial scale slightly. Therefore, a convenient scale reading to use in the following steps should be one where the setscrew is accessible.

- () Refer to Figure 1-3 and position the coil of the Dip Meter close to (or through) the pickup coil. Turn the tuning dial of the Dip Meter until a frequency is indicated on the counter that appears on the dial scale. For example, if you selected the green coil, a convenient frequency might be 25.0 MHz.
- () If necessary, loosen the tuning dial setscrew, adjust the dial to the frequency indicated on the counter, and then retighten the setscrew.

This completes the "Calibration" of your Solid-State Dip Meter. Turn the Meter Off and remove the test coil from its socket.

FINAL ASSEMBLY

Refer to Pictorial 8-1 for the following steps.

- () Secure the right side panel to the chassis with a 6-32 x 3/8" black screw through the side of the panel and into the chassis.
- () Turn the Dip Meter top-side-down. Then secure the right side panel, front and rear, with two 6-32 x 3/8" black screws.
- () Remove the backing from the four feet and press the feet in place on the underside of the side panels as shown in the Pictorial. Position each foot approximately 1/8" inside of each front and rear corner.

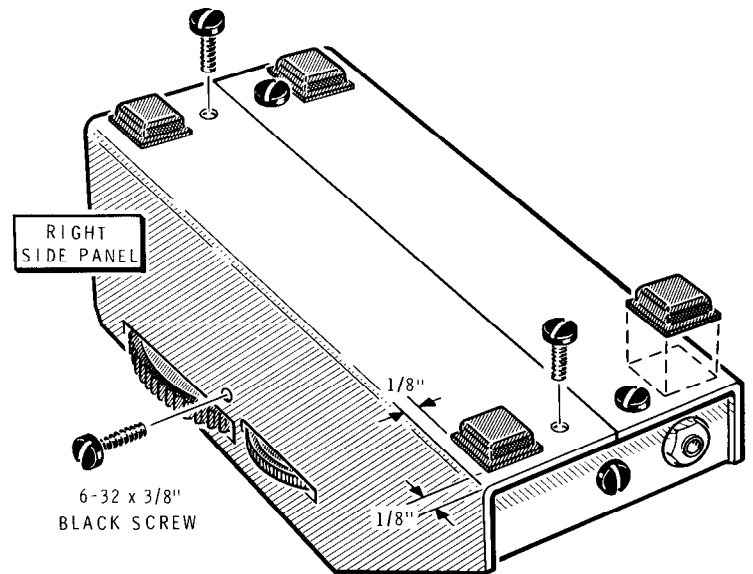

PICTORIAL 8-1



CARRYING CASE

Refer to Pictorial 9-1 for the following steps.

- () Position the carrying case on your work area as shown in the Pictorial.
- () Remove the backing paper from the 5-3/4" x 7-3/8" foam pad and press the pad into the recess inside the top cover of the carrying case.
- () Close the carrying case cover. Then, carefully peel the paper backing from the "Heathkit" label and press the label in place in the recess under the carrying handle.

EXTENSION PROBE

NOTE: There may be applications for your Dip Meter where it will be impractical to get the whole coil and instrument into cramped spaces. The following steps permit you to construct an extension probe that will effectively let you reach into confined areas with your Meter. The materials for the extension probe are not provided with your kit.

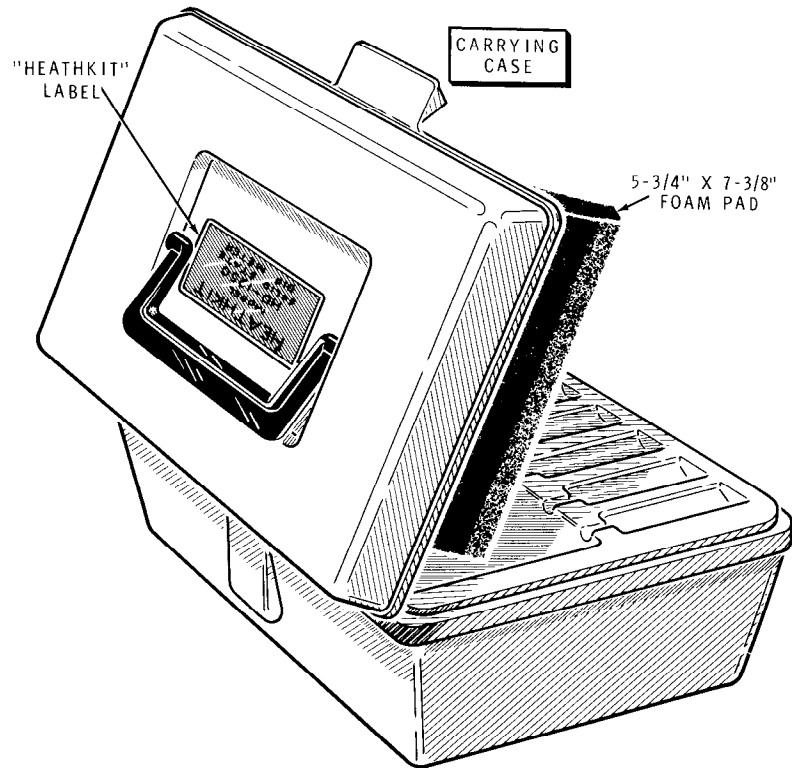

PICTORIAL 9-1

Refer to Pictorial 10-1 for the following steps.

- () Cut a 2' length of shielded cable (not supplied). Remove 1" of the outer insulation from each cable end. Tightly twist the shield lead at each cable end and apply a small amount of solder to hold the small strands together. If necessary, twist the center conductor strands together and apply solder to hold them together.
- () Cut a 13" length of hookup wire and form it into four loops as shown. Remove 1/4" of insulation from each wire end. Then solder one end of the wire to the inner lead of the coaxial cable (S-1) and the other end of the wire to the shield lead of the cable (S-1).

NOTE: You may use any suitable link, either loop or coil, as a pickup element on the opposite end of the coaxial cable. The following step is one method of forming the pickup element.

- () Cut a 10" length of wire. Form three loops in the center of the wire as shown in the Pictorial. Remove 1/4" of insulation from each wire end. As in the previous step, connect the wire ends to the inner and shield leads of the free end of the coaxial cable.

This completes the step-by-step assembly of your Solid-State Dip Meter.

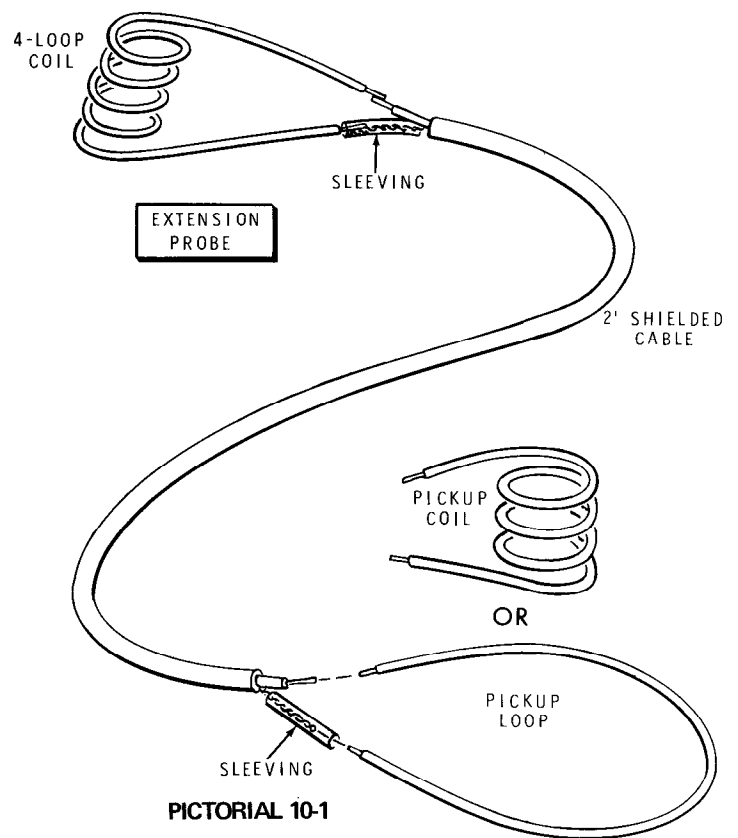

OPERATION

NOTE: Specific uses for your Solid-State Dip Meter are outlined in the "Applications" section of this Manual on Page 47. The fundamental procedure is presented in this "Operation" section.

IMPORTANT NOTE: You should always observe certain precautions when you use your Dip Meter. Some of these are:

1. Protect the Dip Meter from strong RF fields. These can damage electronic components in the Dip Meter, even when the unit is turned off.
2. To conserve batteries, keep the unit turned off when it is not in use.
3. Use only magnetic or dynamic headphones with your Dip Meter.
4. Do not force the main tuning dial beyond the tuning capacitor stop points; you will have to recalibrate the instrument.
5. Do not use any power source other than the battery type recommended. An electronic power supply can cause the Dip Meter to malfunction.

CAUTION: If the Dip Meter coil or case should come in contact with high voltages in units under test, a severe or fatal shock may result.

Each of the seven pickup coils supplied with your Solid-State Dip Meter is color coded to match a color band on the tuning dial of the instrument. When you know the approximate resonant frequency of the circuit to be tested, find that frequency on one of the dial scales. Note the color of the dial scale. Then, locate the coil whose color matches that dial color. Plug the coil into the coil socket on the rear of the Dip Meter.

Figure 2-1 is an illustration which shows the Dip Meter with a coil installed, prepared for a typical operation.

INJECTION MODE OF OPERATION

If the approximate resonant frequency of the circuit under test is known, select the proper coil and plug it into the coil socket. Then, adjust the Dip Meter in the following manner:

1. Depress the pushbutton switch to turn the Meter on.
2. Turn the OSC LEVEL control until you obtain a midscale reading. Rotate the tuning dial through its entire range and note that there is a noticeable tapering in the meter level at each end of the dial range. This is normal.

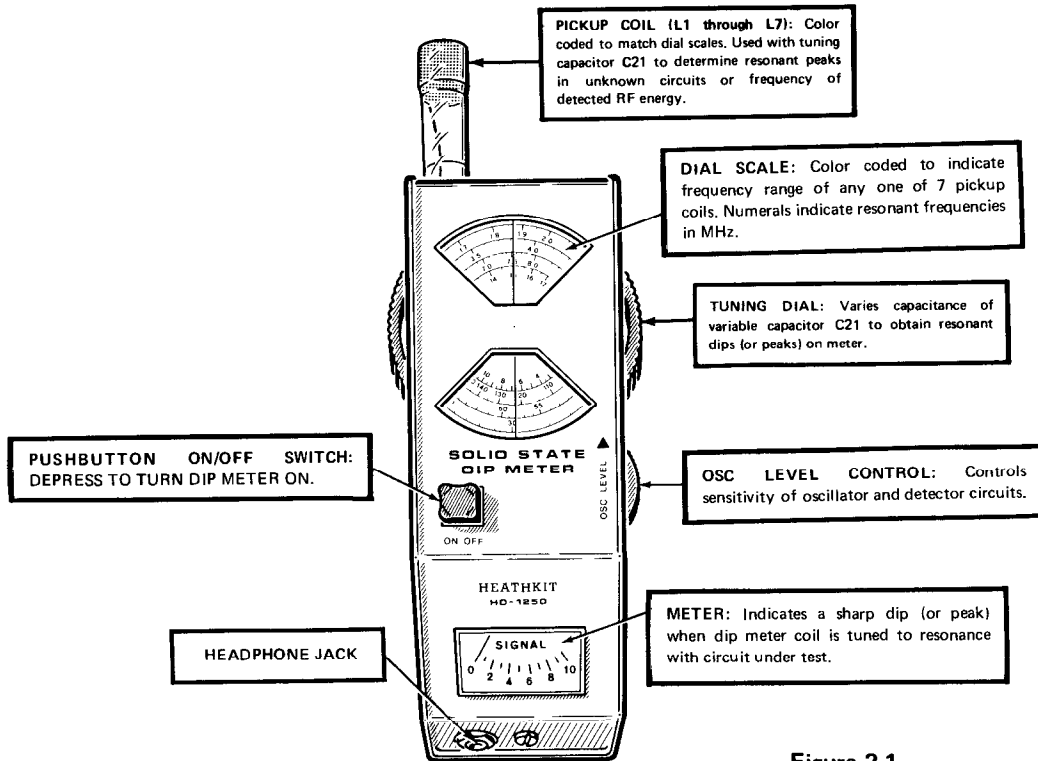
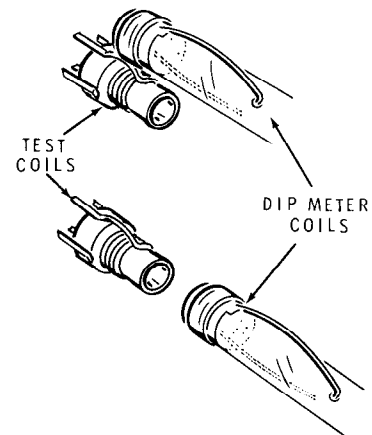

Figure 2-1

3. Refer to Figure 2-2 and position the end of the meter coil close to, and directly in line with, the coil or inductance to be tested.
4. Slowly turn the tuning dial from one extreme toward the other. At the point of resonance, the meter indication should drop abruptly, and almost immediately rise again to the nonresonant meter level.
5. Carefully turn the tuning dial back and forth across the point of meter dip until you locate the lowest point of indication on the meter scale. Slowly move the dip meter coil from the coil under test to reduce the coupling, and re-dip the meter.
6. Read the tuning dial scale on the color that corresponds with the coil you have chosen, and note the frequency in megahertz.



CORRECT ALIGNMENT OF COILS

Injection Mode Theory

Refer to Figure 2-3 as you read the following information.

*In the injection or oscillator mode of operation, the Dip Meter operates as an absorption trap.

As shown in Figure 2-3, test circuit $L_t - C_t$ is not energized and has a resonant frequency f_0 . When you tune the Dip Meter to that frequency, mutual coupling between L_t and the pickup coil causes a high circulating current to develop in the test circuit. Simultaneously, a high impedance is reflected into the oscillator circuit and degenerates or "dips" the level of oscillation. This change in level is detected and then indicated on the instrument meter. The resonant frequency of the test circuit is then read directly from the calibrated dial.

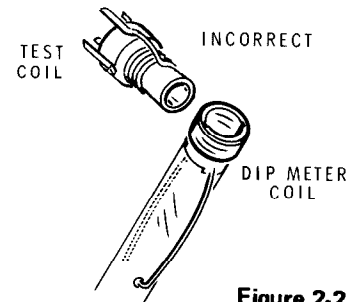

Figure 2-2

ABSORPTION WAVE METER MODE OF OPERATION

CAUTION: When you use the Dip Meter near energized RF circuits, start with the Dip Meter some reasonable distance away from the circuit to avoid overdriving the meter circuits.

Adjust the Dip Meter in the following manner:

1. If possible, select a coil whose frequency range will cover that of the unknown circuit. For example, the IF frequency in FM circuits will be at or near 10.7 MHz. If the circuit under test were in a stereo IF circuit, logically the yellow coil would be used to make the test, since the range of the coil is 6.3 to 13 MHz. Plug the coil into the coil socket.
2. Press the pushbutton to turn the Dip Meter On.
3. Turn the OSC LEVEL control to obtain a midscale reading on the meter.
4. Turn the tuning dial from one extreme to the other and note the taper of the reading at both ends of the dial. Select the very highest reading possible; then leave the tuning dial set at that point.
5. Carefully turn the OSC LEVEL control to reduce the meter reading just to the zero point. Leave the OSC LEVEL control at this setting.

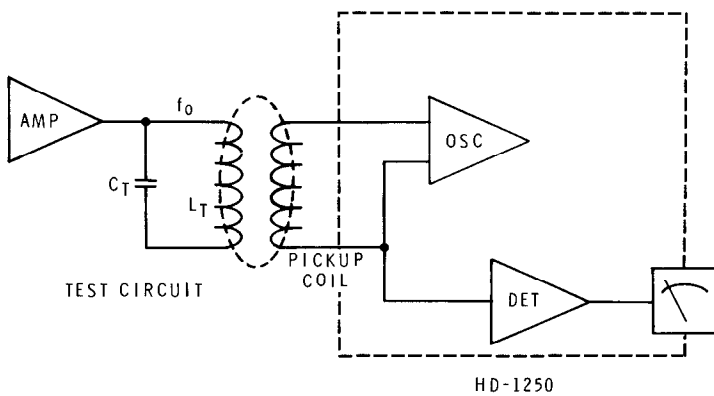

Figure 2-3

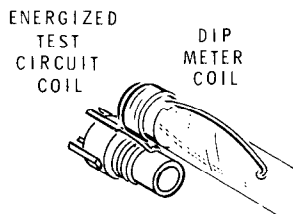

Figure 2-4

6. Closely couple the Dip Meter coil to the test circuit as shown in Figure 2-4.
7. Slowly turn the dial from one extreme toward the other. As the Dip Meter tunes to the electromagnetic field of the test coil, the meter will quickly rise to a peak indication.
8. Very carefully turn the tuning dial back and forth to obtain the highest meter reading while you slowly pull the Dip Meter away from the test coil.
9. Read the frequency, in MHz, of the test circuit directly from the scale whose color is the same as that of the chosen coil.

Absorption Mode Theory

In the absorption mode of operation, the Dip Meter detects the presence of external RF energy. Test circuit $L_t - C_t$ in Figure 2-5 is energized and inductively couples its energy to the Dip Meter pickup coil. As the Dip Meter is tuned to this frequency, a circulating current develops in the Dip Meter tank circuit. Regeneration within the oscillator circuit is insufficient for oscillation, but acts as a Q-multiplier and increases the selectivity of the RF detector. This external energy is then indicated on the meter as a peak at the resonant frequency.

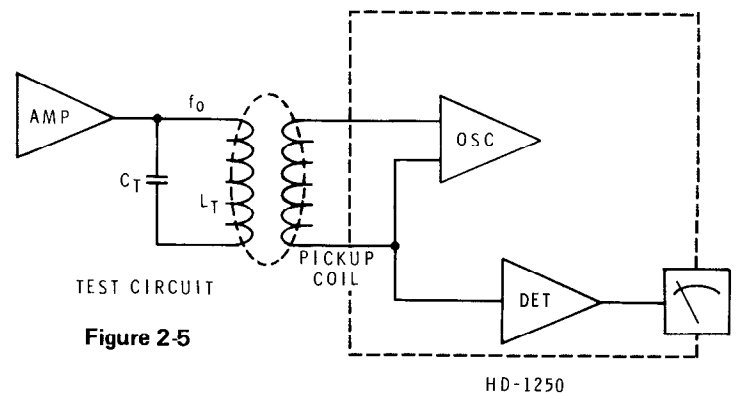

Figure 2-5

HEADPHONES

In dip meter applications, headphones are not frequently used. In some situations, however, they may be helpful. When the Dip Meter is used with the headphones, and the tuning dial is moved across a point of resonance, usually the indication will be a clicking sound in the phones. There is an exception. When an RF circuit is modulated with an audio signal, this audio will be reproduced in the headphones, providing it is of sufficient amplitude.

LOG SCALE

A log, or general reference, scale is included on the inner ring of your dip meter dial. If you wish to make additional plug-in coils, you may use this 0 to 17 uncolored scale to correlate frequency-to-dial readings.

APPLICATIONS

Although there are many applications for your Solid-State Dip Meter, only a few will be described in this section of the Manual.

<u>APPLICATION</u>	<u>PAGE</u>
– Receiver adjustment.	47
– Transmitter adjustment.	48
– Shunt and series trap adjustment.	48
– To measure the Q of a tuned circuit.	48
– To find an unknown capacitor value.	50
– To find the inductance of RF coils.	51
– To find the inductance of toroid coils.	51
– To check for parasitic oscillations.	51
– Neutralization.	52
– Use a relative field strength meter.	52
– Antennas	53

NOTE: In all applications, coupling between the Dip Meter and the test circuit **should** be as loose as possible. That is, keep the dip meter coil as far away from the test circuit as possible and still be able to observe a useable meter reading.

RECEIVER ADJUSTMENT

1. Without power applied to the receiver, tune the receiver local oscillator stage to its approximate frequency, as you use the Dip Meter in its injection mode.
2. As you work toward the antenna, align any doubler stages to their approximate frequencies.
3. Align the RF front end to its center frequency.
4. If the receiver IF is within the coil-coverage of the Dip Meter, align the IF stages.
5. Turn the receiver on, and prepare the Dip Meter for use in the absorption mode.
6. Set the Meter to the frequency corresponding to the receiver oscillator-multiplier stages. Then adjust these stages for a maximum meter reading. Be sure to keep the coupling loose.
7. Set the Dip Meter frequency to the center frequency of the receiver bandspread.
8. Place the dip meter coil (wrapped with a short antenna) near the receiver antenna; this injects a signal. If the output of the Dip Meter is too strong, move it further from the antenna. **NOTE:** Keep the Dip Meter away from large surface areas of metal to avoid detuning its oscillator circuit.
9. Tune receiver stages for desired performance.
10. Lightly tap the dip meter case; this will generate microphonics you can hear at the receiver output.



TRANSMITTER ADJUSTMENT

1. Use the Dip Meter in the injection mode.
2. Turn the transmitter on, but do not apply plate voltage.
3. Pretune all resonant circuits to their respective frequencies.
4. Change the Dip Meter to the absorption mode.
5. Apply final voltage to the transmitter.
6. Start with a large coupling distance as you search for the transmitter frequency. Decrease coupling until the signal is detected on the meter or heard in the headphones.
7. Peak the individual circuits of the transmitter as you use the transmitter's meters or the Dip Meter (in the absorption mode).

SHUNT AND SERIES TRAP ADJUSTMENT

NOTE: Other passive filters may also be aligned if you use the method described in the following steps.

1. Use the Dip Meter in the injection mode.
2. For parallel traps, position the coil close to the test circuit. Tune the Dip Meter for a dip indication on the meter; read the resonant frequency from the tuning dial.

3. To determine the resonant frequency of series traps, the inductor and capacitor must first be connected in parallel. Then, find the resonant frequency as outlined in the previous step. Replace the components back into the circuit in their original series arrangement.

TO MEASURE THE Q OF A TUNED CIRCUIT

Refer to Figure 3-1 for the following steps.

1. Use the Dip Meter in the injection mode.
2. Connect a high impedance input voltmeter (through an RF probe) across the test circuit as shown in Figure 3-1. Use the lowest range of the voltmeter.
3. Loosely couple the Dip Meter to the tank circuit. Adjust the Dip Meter for a maximum reading on the voltmeter. IMPORTANT: Do not change the coupling during the rest of this operation.
4. Read the Dip Meter frequency from the scale whose color corresponds to the color of the coil used for this test. Record the frequency; this is F_0 .
5. Carefully decrease the Dip Meter frequency to obtain a voltmeter reading equal to 70.7% of the F_0 reading. Record this frequency as F_1 .
6. Carefully increase the Dip Meter frequency, past center frequency F_0 , to obtain another voltmeter reading equal to 70.7% of the peak voltage at F_0 . Record this frequency as F_2 .

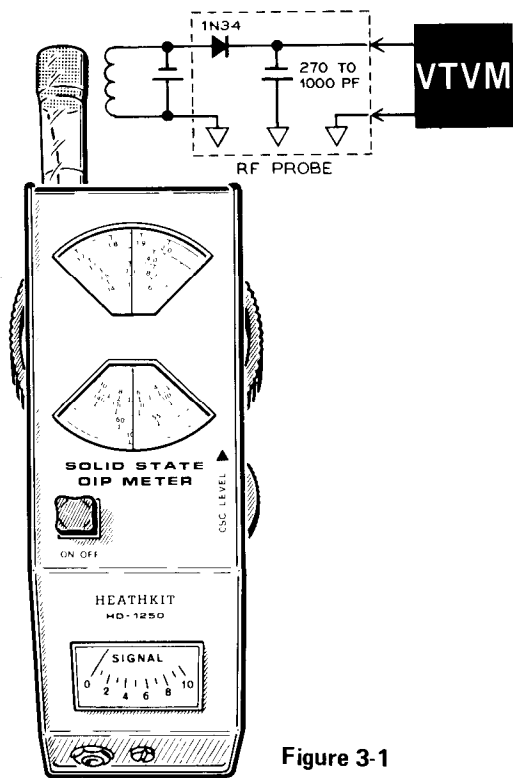

Figure 3-1

NOTE: The result of the readings can be plotted on a graph similar to that shown in Figure 3-2.

7. Calculate the Q of the circuit using the following formula:

$$Q = \frac{F_0}{F_2 - F_1}$$

Relative Q

The Relative Q of a circuit may be determined by observing the indication of the Meter when it is used in the injection mode.

As you observe the dip in the meter pointer, a sharp dip and rise at resonance indicates a circuit having a relatively high Q. A broad, shallow dip in the meter indication indicates a relatively low Q.

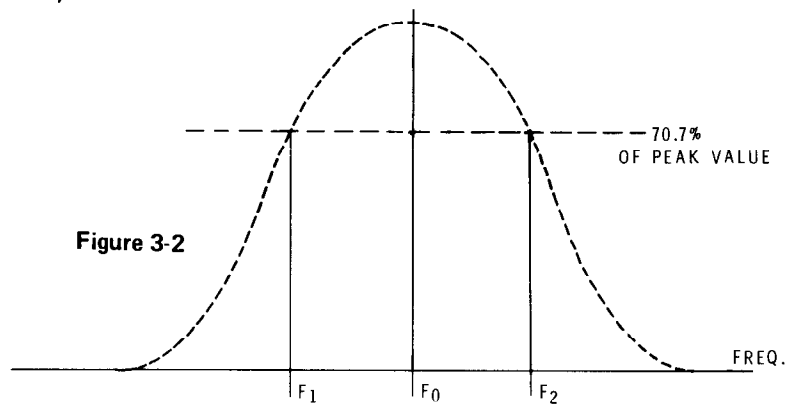

Figure 3-2



TO FIND AN UNKNOWN CAPACITOR VALUE

Refer to Figure 3-3 for the following steps.

1. Connect the unknown capacitance across a phono socket as shown.
2. Plug any of the pickup coils, except the brown coil, from the dip meter set into the phono socket.
3. Adjust the Dip Meter for use in the injection mode of operation. NOTE: By trial and error, you may need to plug any of the remaining coils into the coil socket on the Dip Meter to determine the resonant frequency of the "test circuit." Record the frequency (f), in MHz, from the dial.
4. Refer to Table A and find the color of the coil which you used in the phono socket. Record the value of the inductor (L) in henries.
5. Substitute the recorded quantities in the formula below to determine the value of the unknown capacitor in farads:

$$C = \frac{1}{4\pi^2 f^2 L} = \frac{1}{39.48 \times f^2 \times L}$$

- Note: 1 MHz = 10⁶ Hertz
 1 μF = 10⁻⁶ farads
 1 pF = 10⁻¹² farads
 f = dial reading (MHz)
 L = Inductance (in Henries)

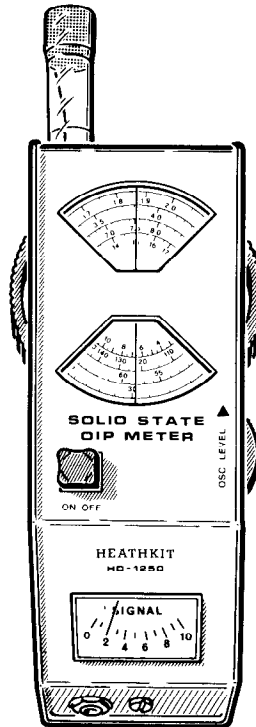

COIL	COLOR	INDUCTANCE
L1	Red	171 μH
L2	Orange	41.1 μH
L3	Yellow	10.2 μH
L4	Green	2.62 μH
L5	Blue	0.72 μH
L6	Violet	0.196 μH
L7	Brown	*

*Do not use to calculate formulas.

TABLE A

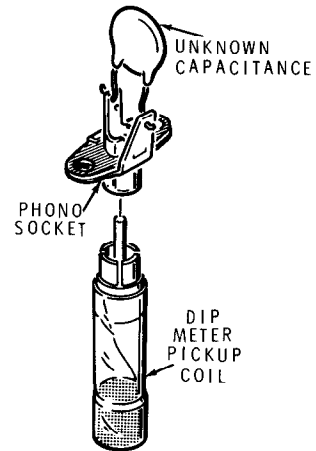

Figure 3-3

TO FIND THE INDUCTANCE OF RF COILS

1. Connect a low value capacitor across the unknown inductor; for example 100 pF.
2. Use the Dip Meter in the injection mode.
3. By trial and error, find a coil that will dip on the resonant frequency of the parallel circuit. Record the frequency.
4. Compute the inductance of the coil with the following formula:

$$L = \frac{1}{39.48 \times f^2 \times C}$$

$$1 \mu\text{H} = 10^{-6} \text{ henries}$$

$$1 \text{ mH} = 10^{-3} \text{ henries}$$

TO FIND THE INDUCTANCE OF TOROID COILS

The previous steps cannot be applied to toroid coils because they have self-shielding properties. However, these coil values may be determined in the following manner:

1. Use the Dip Meter in the injection mode.
2. Connect the extension probe to several loops of wire wound around the core of the coil. A magnetic flux will be picked up in the special-wound link and coupled to the Dip Meter. See Figure 3-4.
3. Compute the unknown inductance as in the previous section.

TO CHECK FOR PARASITIC OSCILLATIONS

1. Apply power to the transmitter.
2. Use the Dip Meter in the absorption mode.
3. Carefully check transmitter stages for undesired frequencies.
4. Once a parasitic oscillation has been located, turn off transmitter power.
5. Use the Dip Meter in the injection mode. Check the areas of the transmitter near the point the first resonance was detected, at or near the original frequency. Check circuit wiring, RF chokes, circuit grounds, and other potential resonant circuits.

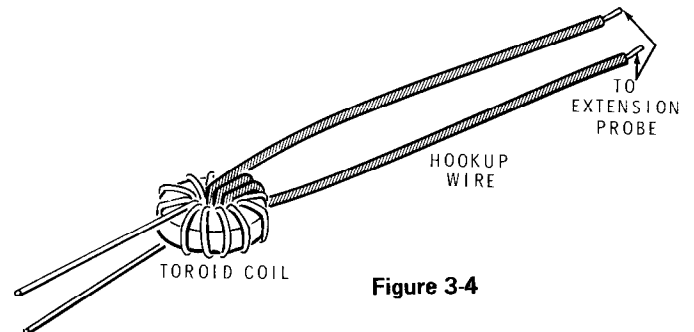

Figure 3-4

NEUTRALIZATION

1. Remove the final voltage from the transmitter.
2. Apply power to the driver stage.
3. Use the Dip Meter in the absorption mode.
4. Couple the dip meter coil to the output of the stage being neutralized.
5. Adjust the Dip Meter to the driver frequency to obtain a maximum meter deflection.
6. Adjust the neutralizing capacitor for a minimum meter reading.

USE AS A RELATIVE FIELD-STRENGTH METER

Refer to Figure 3-5 for the following steps.

1. Connect a short antenna around the dip meter pickup coil as shown.
2. Set the Dip Meter for use in the absorption mode.
3. Tune the Dip Meter to the resonant frequency of the transmitter output.
4. Position the pickup antenna at various points around the transmitting antenna to determine relative strength.

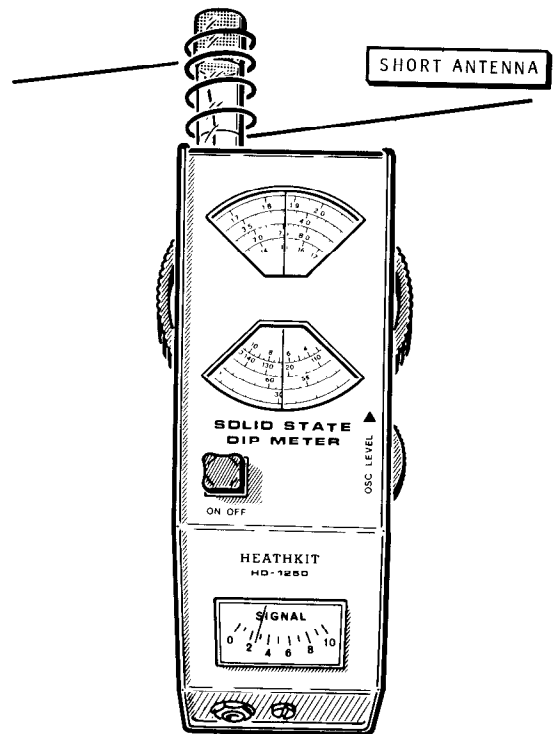

Figure 3-5

ANTENNAS

Use the Dip Meter in the injection mode. When you couple to an antenna, the meter should be coupled at the low impedance or high current point as shown in Figure 3-6. For a half-wave antenna, this point is at the center, and for longer wires, it is at points of odd quarter wavelengths. as measured from either end of the antenna. A full-wave antenna will not be a half wave at its half-resonant point. This is because end effects are only at the ends of the antenna, and will be absent at other points when the antenna is a full-wave length, or longer. The antenna should be positioned as near its operating location as possible under the conditions desired during operation.

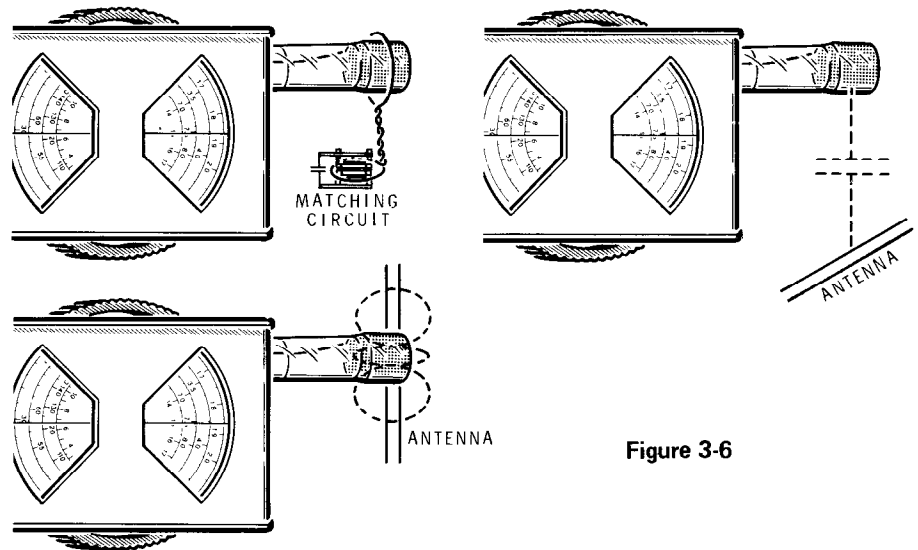

Figure 3-6

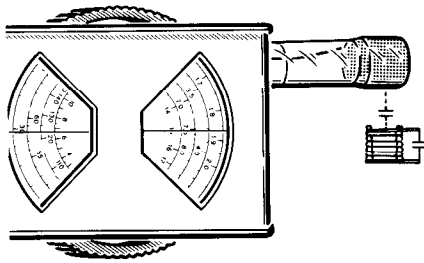

Figure 3-7

If you cannot reach a low impedance point, you may make a check at a high impedance or high voltage point. Use capacitive (right-angled) coupling as shown in Figure 3-7. Note that if the high impedance point is near either end of the antenna, the end-effect will be altered due to the presence of the Dip Meter, and the resonant frequency of the antenna will tend to increase slightly. You must take this into consideration when measuring antenna ends; the reading will be slightly lower than the true antenna resonant frequency. This difference will be from 1-1/2 to 3%.

In each case, remember the physical length as opposed to electrical length (half-wave, full-wave, etc.) as calculated by formula.

To make the measurements described, you must remove the feeder lines from the antenna. Such feeders would have to be perfectly balanced and matched or terminated. True antenna resonance cannot be indicated because unmatched feeders or incorrectly terminated feeders will provide positive or negative reactances which will alter the electrical length of the antenna.

In some cases, large antenna elements may present a difficult situation when you attempt to couple your Dip Meter to them. A small wire coupled across a foot or so of the antenna at the center may provide sufficient coupling to obtain a reading.

Should you wish to measure an antenna with an open center, close it temporarily with the shortest possible wire during the measurement. This must also be done with a folded-dipole antenna. Do not forget to remove this wire before you connect the feeder lines again.

Tuned (Resonant) Feeders

Adjust the Dip Meter for use in the injection mode. Check for the desired resonant point on the series or parallel tuned circuit at the transmitter end of the feeder. If you cannot obtain a resonance indication at the desired frequency, alterations may be made in the tuned circuit or in the feeder length according to the actual resonant frequency found. Do not be confused by other resonant indications. You must remember that a Zepp antenna, for instance, is a long-wire antenna partially folded back on itself and you may observe resonances at frequencies both above and below the desired frequency.



Untuned (Nonresonant) Feeders

After an antenna has been adjusted to its correct length, you may connect an untuned feeder line to it, provided some type of matching device is used. A correct match may be obtained if you make the necessary adjustments in conjunction with an impedance bridge or a standing-wave ratio bridge. In this application, you will use the Dip Meter as an injection device.

If you use an impedance bridge or the SWR meter, it should have a meter whose full-scale sensitivity is 200 μ A or less to obtain the most accurate readings. Couple the Dip Meter to the circuit as loosely as possible to obtain an accurate reading. If you employ tight coupling, frequency calibration may shift slightly.

Adjust the matching instrument for a reading as close to a unity standing-wave ratio as possible. If you cannot obtain a satisfactory ratio, you may have a fault in the matching system, or a shift in antenna resonance has occurred. You may check the latter circumstance by very slightly varying the Dip Meter tuning until a lower SWR is found or until a better null is seen on the meter of the bridge. This will be the resonant frequency of the antenna. You may then need to change the antenna length until a correct SWR is seen at the desired frequency. The matching system, then, may also require some adjustment.

Parasitic Beams

Use the Dip Meter as an injection device. Adjust the driven element of the beam for resonance. Disconnect the feeder lines; then adjust the parasitic elements to

their calculated correct length. If the driven element is open at the center, use a short wire to close it temporarily. When this element has been properly adjusted, connect and match the feeder line as outlined in the previous paragraph. Be sure to open the center of the driven element if the matching system requires it. Adjust the parasitic elements as you use the Dip Meter as a signal generator coupled to the feeder line. Place a receiver some distance from the transmitter antenna and observe the readings of the receiver S-meter when the unit is connected to a short antenna. Observe the actual relative field-strength reading on the S meter after each adjustment is made. The Dip Meter should be coupled as loosely as possible. Check the actual frequency of the Dip Meter occasionally on the receiver as you make these adjustments.

After you have adjusted the parasitic elements, check the SWR again. The SWR will probably have changed as the adjustment of other elements will likely change the point of resonance in the antenna. You may wish to again refer to the previous section on "Untuned (Nonresonant) Feeders." Once you have completed these steps, they should be repeated to "peak up" the circuit.

If your beam is situated so surrounding objects may cause the system to detune as the beam is rotated, the steps outlined above may have to be performed in the direction your antenna will be pointed during its periods of most frequent use, or where the greatest degree of rotation has the least detuning effect.

If you wish, you may use the transmitter as a signal generator, and the Dip Meter is its absorption mode to perform these adjustments. However, this method is less desirable because unnecessary QRM (interference or noise) may be generated. Also, this method, when properly performed, will require more than one person.

Shorted Quarter-Wave Lines

Use the Dip Meter in the injection mode. Couple to open wire lines as shown in Figure 3-8, and to coaxial lines as shown in Figure 3-9. As you adjust the lines for correct length, temporarily install the connectors that will be fitted to the lines upon completion. Roughly calculate the frequency of the line. Resonant points can be found at three times the quarter-wave lengths, five times the quarter-wave length, and so on.

Open Quarter-Wave Lines

Connect a short at one end of the line, then measure as for the shorted line. Because of the length of the shorting line, a slight error will be introduced, depending on the line spacing. The closer the spacing, the less error will be encountered.

If the line is coaxial, the short at the open end should be as small as possible between the shield and the inner conductor. Include the fittings in your measurements. After you make the measurements, remove the short from the cable.

Shorted Half-Wave Lines

Use the Dip Meter in the injection mode. Couple at the center of the line as shown in Figure 3-10. For coaxial lines, measure as for a quarter-wave shorted line at half the calculated frequency. A resonant frequency determined in this manner must be multiplied by 2 for the half-wave shorted line.

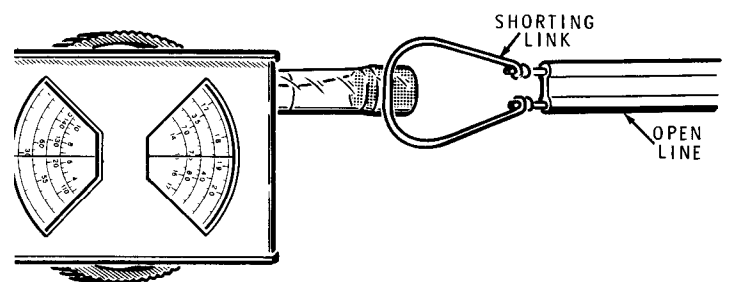

Figure 3-8

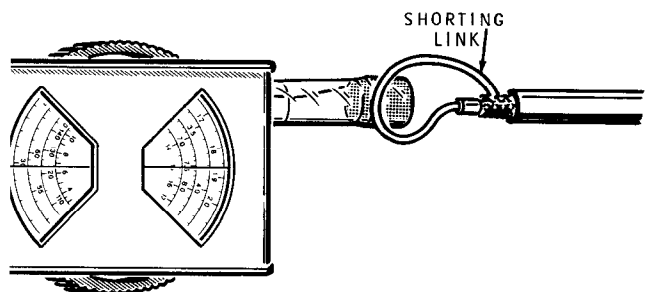

Figure 3-9

Open Half-Wave Lines

Couple at the center of the line as shown in Figure 3-10. When measuring coaxial lines, short the lines at one end and measure as for the quarter-wave shorted line at the calculated 1/2 frequency. Resonant frequency is then multiplied by 2 to determine the correct length of the line after you remove the shorting line.

Standing Waves

Maintain a uniform coupling as you move the Dip Meter along the feed-line by keeping the coil form against the line. This is possible as the coil windings are shielded from direct contact by the coil coating. A "flat" line is determined by the lack of meter fluctuation as you move the coil along the line. Do not overload the dip meter, it is highly sensitive to small changes due to its internal amplifier.

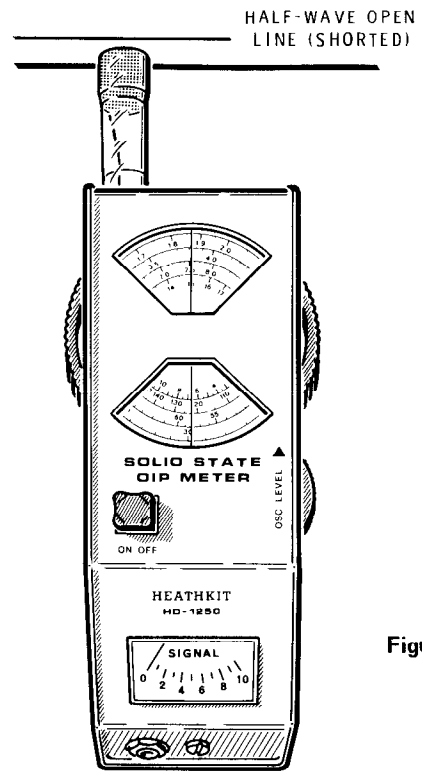

Figure 3-10



IN CASE OF DIFFICULTY

Begin your search for any trouble that occurs after assembly by carefully following the steps listed below in the "Visual Tests." After the "Visual Tests" are completed, refer to the "Troubleshooting Chart."

NOTE: Refer to the "Circuit Board X-Ray Views" on Page 64 for the physical location of parts on the circuit board.

VISUAL TESTS

1. Recheck the wiring. Trace each lead in colored pencil on the Pictorial as you check it. It is frequently helpful to have a friend check your work. Someone who is not familiar with the unit may notice something consistently overlooked by the kit builder.
2. About 90% of the kits that are returned to the Heath Company for repair do not function properly due to poor connections and soldering. Therefore, many troubles can be eliminated by reheating all connections to make sure that they are soldered as described in the "Soldering" section of the "Kit Builders Guide." Be sure there are no solder bridges.
3. Check to be sure that the transistors and diodes are in their proper locations. Make sure each lead is connected to the proper point.
4. Check the values of the parts. Be sure in each step that the proper part has been wired into the circuit, as shown in the Pictorial Diagrams. It would be easy, for example, to install a 47 k Ω (yellow-violet-orange) resistor where a 4700 Ω (yellow-violet-red) resistor should have been installed.

5. Check for bits of solder, wire ends, or other foreign matter which may be lodged in the wiring.
6. Be sure all wires and leads connected to the circuit boards have been trimmed as close as possible to the circuit board foils.
7. A review of the "Circuit Description" may also help you determine where the trouble is.

If the trouble is still not located after the "Visual Tests" are completed, and a voltmeter is available, check voltage readings against those shown on the "Schematic Diagram" (fold-out from Page 67). Read the "Precautions for Troubleshooting" before you make any measurements. NOTE: All voltage readings were taken with a high impedance input voltmeter. Voltages may vary as much as $\pm 20\%$.

NOTE: In an extreme case where you are unable to resolve a difficulty, refer to the "Customer Service" information inside the rear cover of the Manual. Your Warranty is located inside the front cover of the Manual.

PRECAUTIONS FOR TROUBLESHOOTING

Be cautious when you test diode and transistor circuits. Although they have almost unlimited life when used properly, they are much more sensitive to excessive voltage or current than tubes.



Silicon Bipolar Transistor Checking (Q11)

To check this transistor accurately, you should use a transistor checker. However, if one is not available, you can use an ohmmeter to determine the general condition of this transistor. The ohmmeter must have at least 1 volt DC at the probe tips to exceed the threshold of the diode junctions in the transistor being tested. Most vacuum tube and digital voltmeters meet this requirement.

To check a transistor with an ohmmeter, proceed as follows:

1. Remove the transistor from the circuit.
2. Set the ohmmeter on the X1000 range.
3. Connect one of the ohmmeter test leads to the base (B) of the transistor. Touch the other meter lead to the emitter (E) and then to the collector (C). Both readings should be the same, but may be either high or low. If one reading is high and the other low, the transistor should be replaced. (Identify the transistor leads on the "Identification Chart" on Page 66 of the Manual.)
4. Repeat step 3 with the test leads reversed.

NOTE: In the unusual case when the readings are all low, or all high, no matter which ohmmeter lead is connected to the base, the transistor should be replaced.

MOSFET Checking (Q21)

An insulated-gate type MOSFET is used at Q21 on the detector circuit board. Usually any defect in this device is found to be an internal short between the source (S) and one of the gates (G1) or (G2). They can be checked in the circuit with a high impedance input voltmeter (10 megohms or greater). An abnormally low source voltage may indicate an internal short circuit.

CAUTION: If you are going to remove the MOSFET from the circuit board, first wrap a small wire around all four leads to short them together. This is required because some soldering irons have an AC voltage at their tips of an amplitude high enough to short out the protective diodes in the MOSFET. Damage often occurs when an attempt is made to clean the leads of solder without the presence of the shorting wire. During normal installation of these devices, previously installed parts provide the necessary protection — a path to ground so the shorting wire is not necessary.

Troubleshooting Chart

The following chart lists the "Condition" and the "Possible Cause" of a number of malfunctions. If a particular part is mentioned (Q11, R13, C21, etc.) as a possible cause, check that part to see if it is incorrectly wired or installed improperly. Also check to see if an improper part was installed at that location. It is also possible, on rare occasions, for a part to be faulty.

To locate parts, refer to the "Circuit Board X-Ray Views" on Page 64, the "Voltage Charts" on Page 65, or the "Schematic Diagram" (fold-out from Page 67).

CONDITION	POSSIBLE CAUSE
1. No meter indication (red coil installed, oscillator level maximum).	1. Weak battery (less than 7 volts). 2. Coil not fully seated. 3. Open coil (substitute with orange coil). 4. Miswired or open headphone jack. 5. Level control wires reversed. 6. Shorting wire not remove from transistor Q21. 7. Transistors Q11, Q21. 8. Diodes D21, D22. 9. Meter shorting wire not removed. 10. Braid shorting to capacitor C21.

CONDITION	POSSIBLE CAUSE
<p>2. Low or no meter indication (brown coil installed, oscillator level maximum). Unit operates properly with red coil (Step 1).</p>	<ol style="list-style-type: none"> 1. Weak battery. NOTE: Brown coil requires higher voltage than the other coils. 2. Defective coil. 3. Defective grounding. Resolder all three braids to circuit board foils. 4. Insufficient shielding. Be sure side panels are installed with <u>all</u> hardware secure. 5. Oscillator transistor Q11. 6. Resolder coil socket connections.
<p>3. Low meter reading, oscillator level maximum.</p>	<ol style="list-style-type: none"> 1. Weak battery. 2. Diodes D21 or D22.
<p>4. Intermittent meter fluctuations during tuning.</p>	<ol style="list-style-type: none"> 1. Capacitor C21 plates dirty or bent. 2. Washers missing between tuning capacitor and circuit board. See Pictorial 1-3 on Page 16.
<p>5. Meter pointer does not move smoothly across scale as oscillator level control is adjusted.</p>	<ol style="list-style-type: none"> 1. Control R1. 2. Meter. Meter lugs bent.



SPECIFICATIONS

Frequency Range	1.6 to 250 MHz.
Controls	Tuning capacitor. Oscillator level control On/Off switch.
Meter Movement	150 microampere.
Solid-state Circuits	1 NPN transistor oscillator. 1 Dual-gate MOSFET amplifier. 2 Diffused silicon hot carrier diode detectors.
Power Source	9-volt NEDA Type 1604 battery.
Dimensions (less coils)	2" high x 2-5/16" wide x 5-7/8" long. (5.08 cm x 5.87 cm x 14.92 cm.)
Net Weight (Meter, case, and coils)	2 lbs. (.746 kg.)

The Heath Company reserves the right to discontinue products and to change specifications at any time without incurring any obligation to incorporate new features in products previously sold.

CIRCUIT DESCRIPTION

Refer to the Schematic Diagram (fold-out from Page 67) while you read this "Circuit Description."

The Dip Meter is basically made up of an oscillator and a detector circuit. In the injection mode, the oscillator generates the signal which is injected into the circuit under test. Then the detector circuit detects changes in the impedance reflected back from the circuit under test and displays these changes on the meter. In the absorption mode, the oscillator in the Dip Meter is used as a Q-multiplier, but does not oscillate. The detector circuit detects the signal that is already in the circuit under test.

OSCILLATOR

The Solid-State Dip Meter uses a balanced Colpitts RF oscillator. Transistor Q11, a plug-in coil, and split-stator variable tuning capacitor C21 furnish the phase shift required for oscillation. Capacitors C11 and C12 are silver mica coupling capacitors chosen for their inherent stability. Resistor R11 determines the RF input current at low frequencies and is bypassed by capacitor C13 at high frequencies. Transistor Q11 is a uhf bipolar transistor, operating Class A.

Resistor R14 is a load resistor, while resistor R12 provides bias stability. Supply decoupling and a good RF ground is ensured by capacitor C14. Variable resistor R1 is a variable supply control for the oscillator and sets the level of regeneration.

DETECTOR

The voltage impressed across the oscillator tank (one of the coils L1 through L7, and C21) is amplified by a broad-band MOSFET amplifier. In a balanced phase-splitter configuration, transistor Q21 develops two output voltages across resistors R24 and R25. These out-of-phase signals are rectified by series hot-carrier diodes D21 and D22. The detected signals are combined and filtered by capacitors C25 and C26 to develop an average positive-peak DC voltage. This DC voltage is indicated by the Meter which provides mechanical filtering by its movement inertia.

CIRCUIT BOARD X-RAY VIEWS

NOTE: To find the PART NUMBER of a component for the purpose of ordering a replacement part:

- A. Find the circuit component number (R5, C3, etc.) on the "X-Ray View."
- B. Locate this same number in the "Circuit Component Number" column of the "Parts List."
- C. Adjacent to the circuit component number, you will find the PART NUMBER and DESCRIPTION which must be supplied when you order a replacement part.

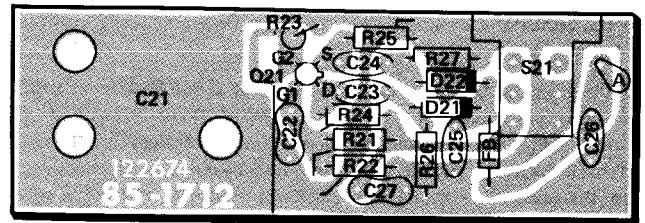

DETECTOR CIRCUIT BOARD
(Viewed from foil side)

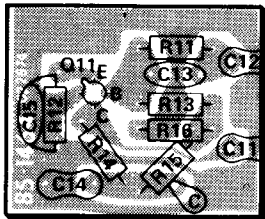

OSCILLATOR CIRCUIT BOARD
(Viewed from foil side)

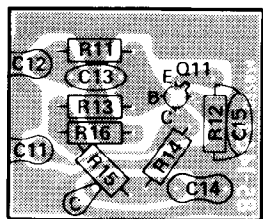

OSCILLATOR CIRCUIT BOARD
(Viewed from component side)

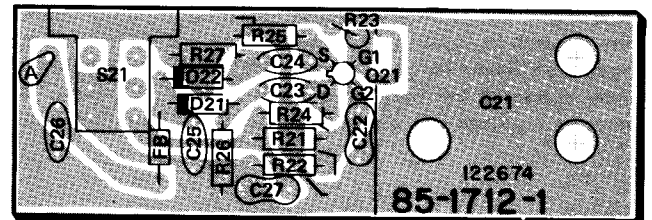

DETECTOR CIRCUIT BOARD
(Viewed from component side)

CIRCUIT BOARD VOLTAGE CHARTS

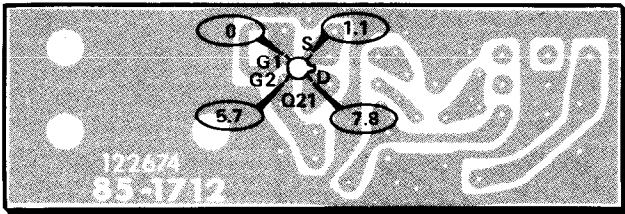

DETECTOR CIRCUIT BOARD
(Viewed from foil side)

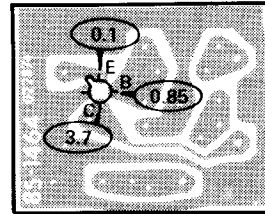

OSCILLATOR CIRCUIT BOARD
(Viewed from foil side)

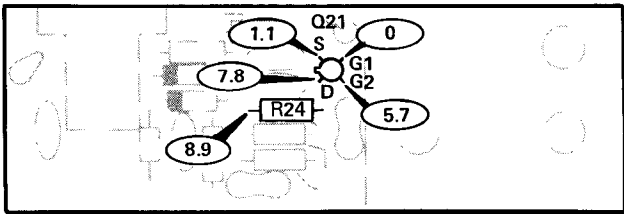

DETECTOR CIRCUIT BOARD
(Viewed from component side)

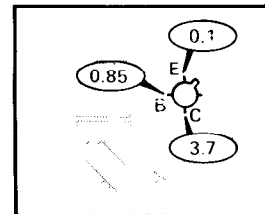



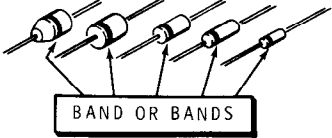
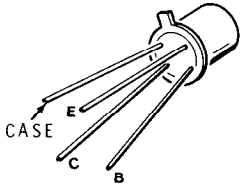
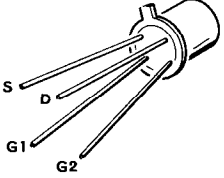

OSCILLATOR CIRCUIT BOARD
(Viewed from component side)

DIODE-TRANSISTOR IDENTIFICATION CHART

COMPONENT	HEATH PART NO.	MAY BE REPLACED WITH	IDENTIFICATION
D21, D22	56-87	FH1100	<p>HEATH PART NUMBERS ARE STAMPED ON MOST DIODES.</p> <p>NOTE: DIODES MAY BE SUPPLIED IN ANY OF THE FOLLOWING SHAPES. ALWAYS POSITION THE BANDED END AS SHOWN ON THE CIRCUIT BOARD.</p> 
Q11	417-290	MRF502	
Q21	417-274	40673 (DIODE-PROTECTED MOSFET)	

NOTES:

1. ALL RESISTORS ARE 1/4-WATT, 5% TOLERANCE UNLESS OTHERWISE NOTED. VALUES ARE IN OHMS (k=1000).
2. CAPACITORS LESS THAN 1 ARE IN μ F; GREATER THAN 1 ARE IN pF.
3.  THIS SYMBOL INDICATES A CHASSIS GROUND.
4.  THIS SYMBOL INDICATES A CIRCUIT BOARD GROUND.
5.  THIS SYMBOL INDICATES AN EXTERNAL CONNECTION TO THE CIRCUIT BOARD.
6.  THIS SYMBOL INDICATES A POSITIVE DC VOLTAGE, TAKEN WITH A HIGH INPUT IMPEDANCE VOLTMETER FROM THE POINT INDICATED TO GROUND, WITH NO COIL IN THE OSCILLATOR CIRCUIT.

PARTS ARE GROUPED AS FOLLOWS

- 1-9 MOUNTED ON CHASSIS
- 11-19 MOUNTED ON OSCILLATOR CIRCUIT BOARD
- 21-29 MOUNTED ON DETECTOR CIRCUIT BOARD

	RANGE	PART NO.	COLOR
L1	1.6-3.4MHz	40-1689	RED
L2	3.2-6.6MHz	40-1690	ORANGE
L3	6.3-13MHz	40-1691	YELLOW
L4	12.5-26MHz	40-1692	GREEN
L5	25-51MHz	40-1693	BLUE
L6	48-100MHz	40-1694	VIOLET
L7	100-250MHz	40-1695	BROWN

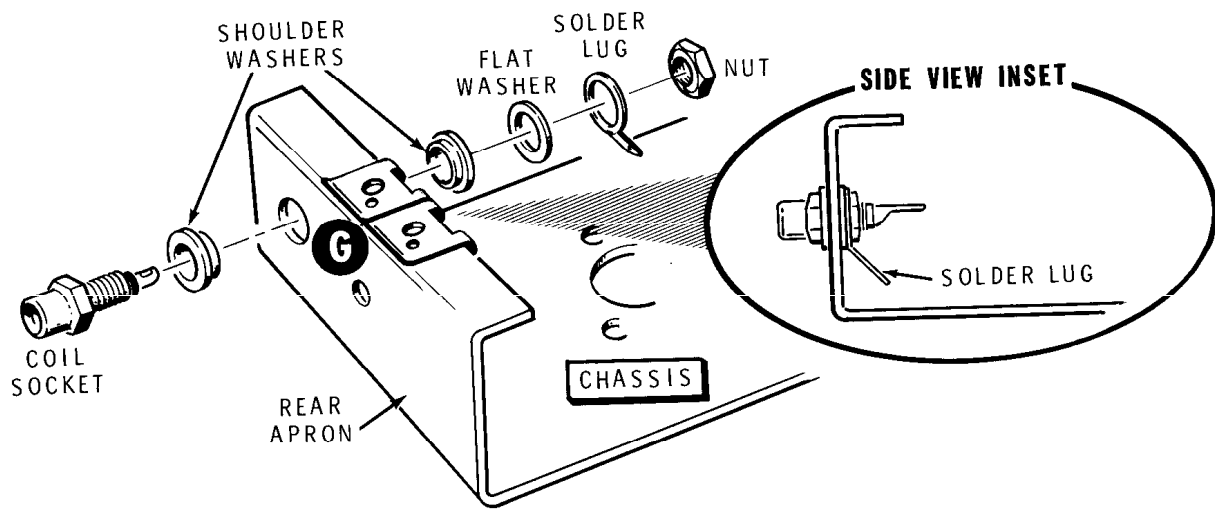

Detail 3-1B

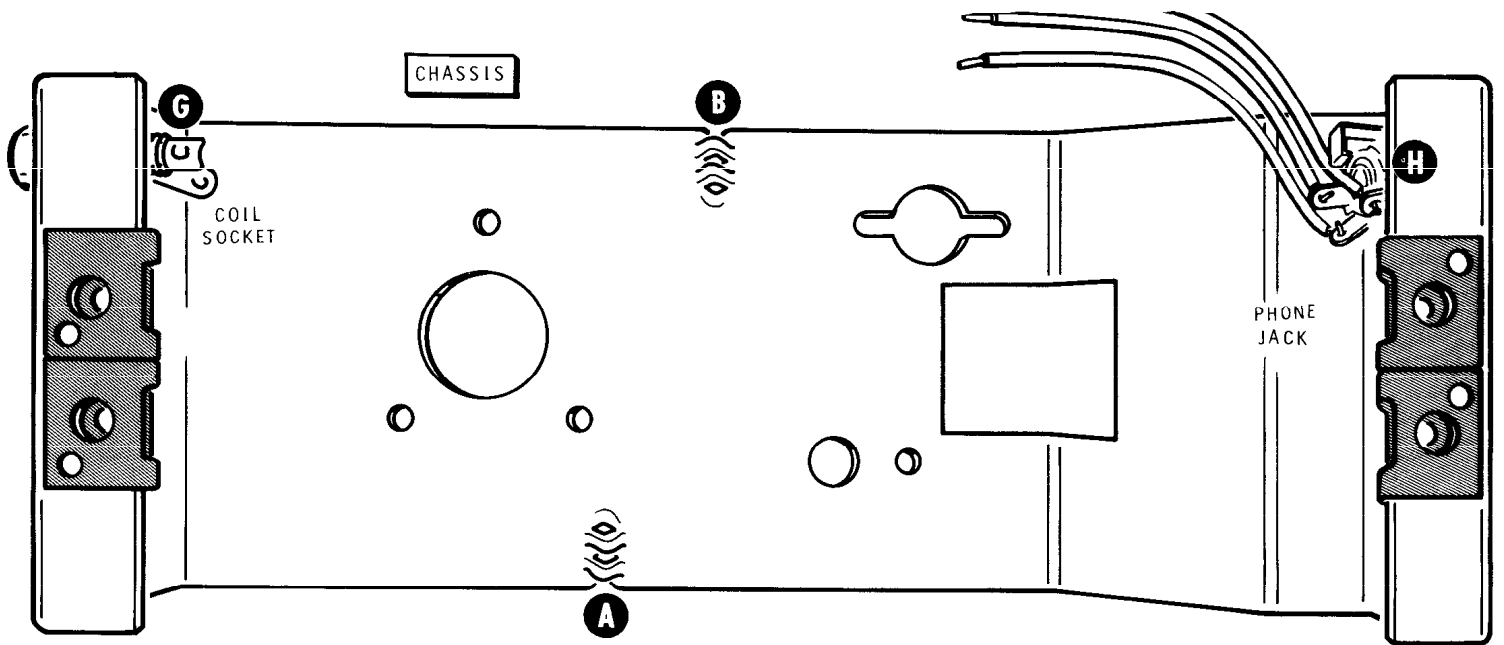

PICTORIAL 3-1

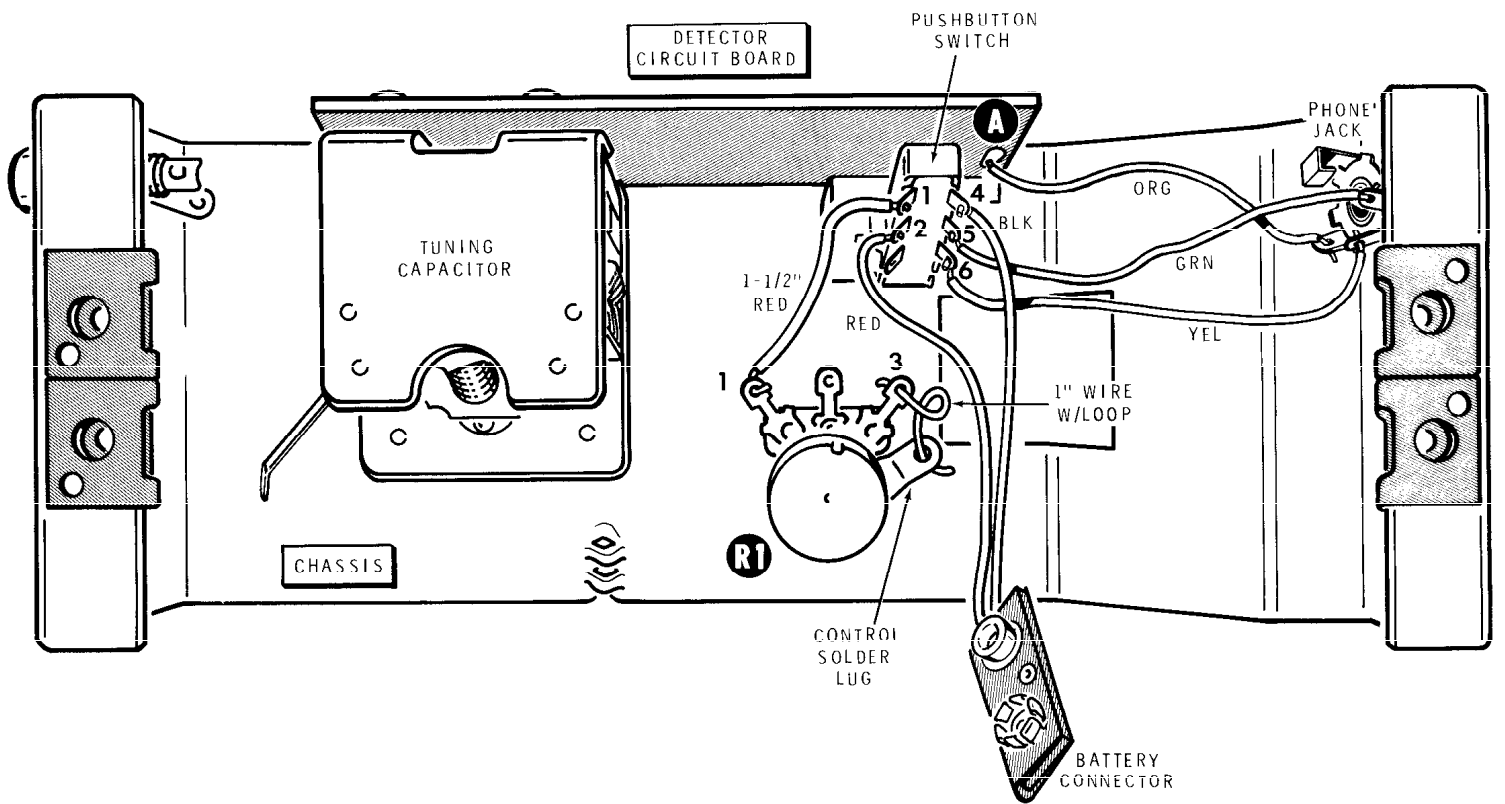

PICTORIAL 3-2

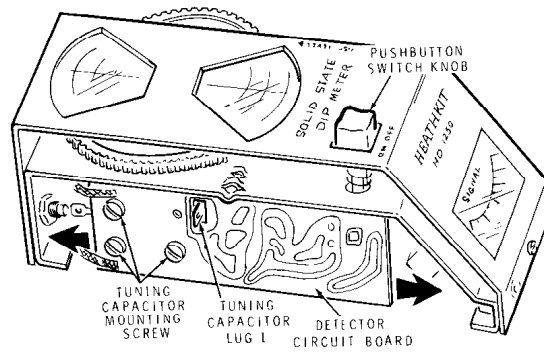
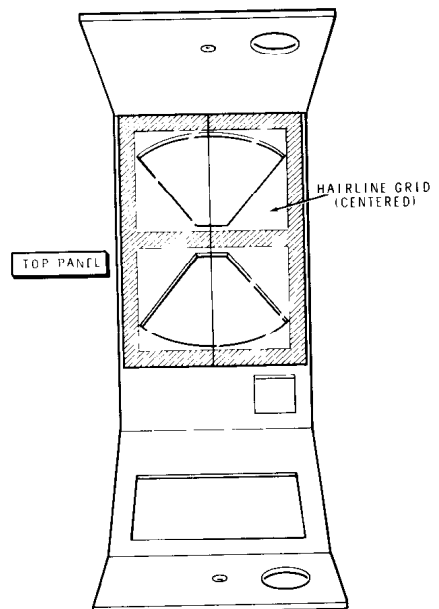
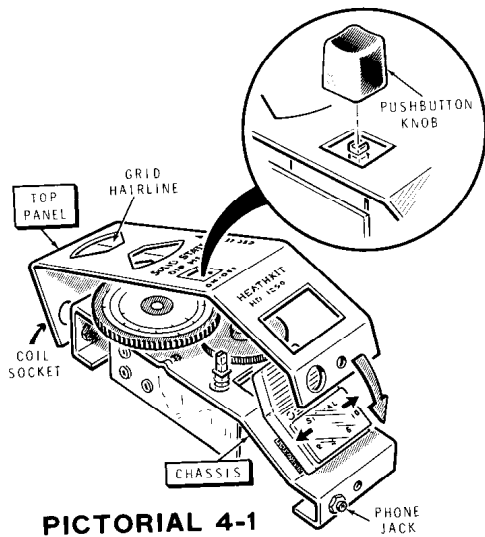

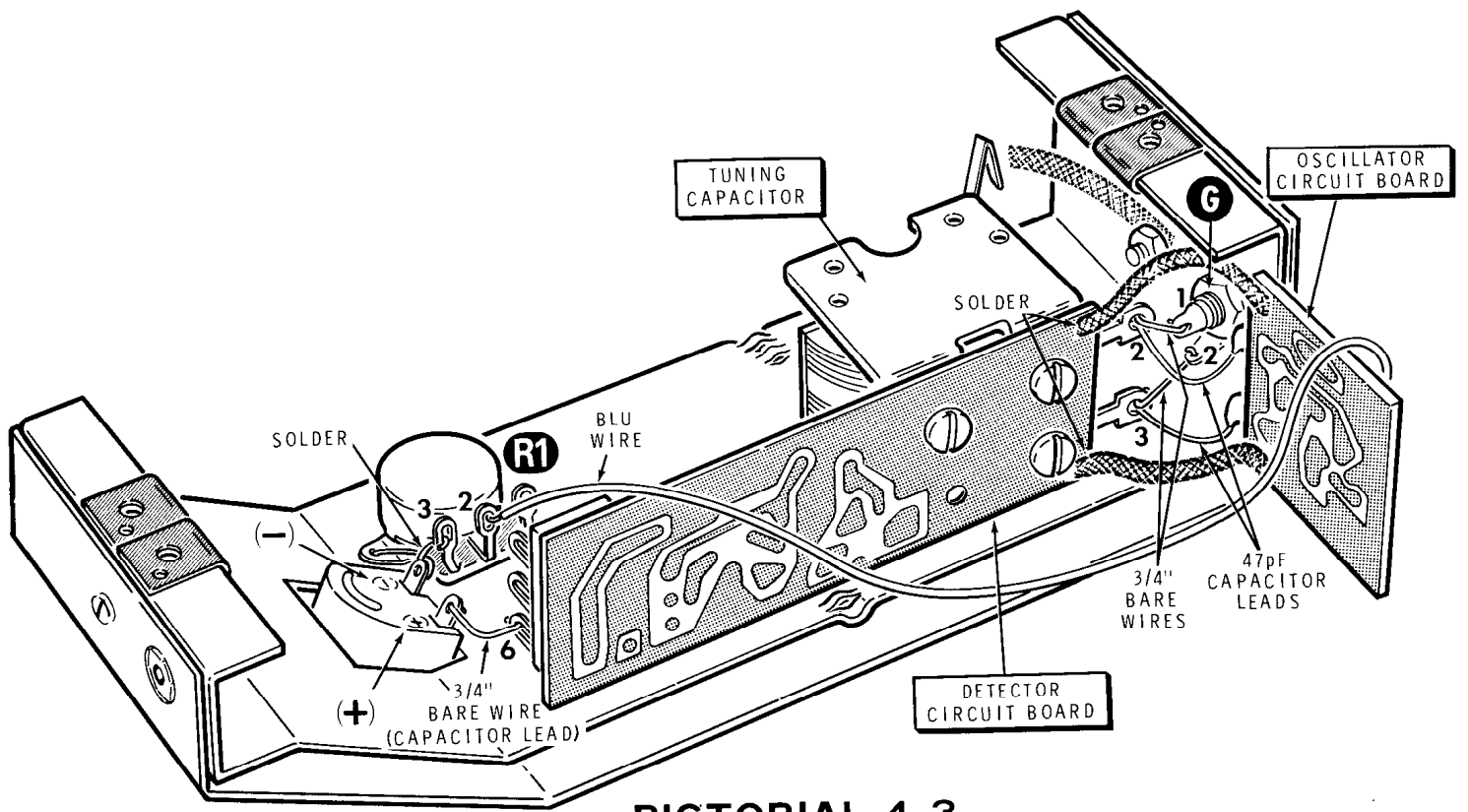

PICTORIAL 4-3

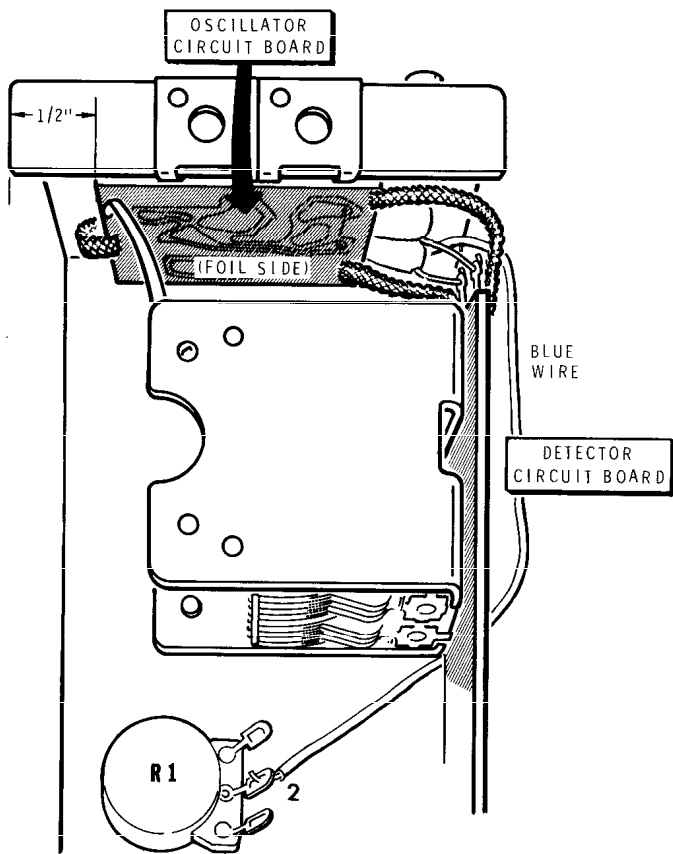

PICTORIAL 6-1

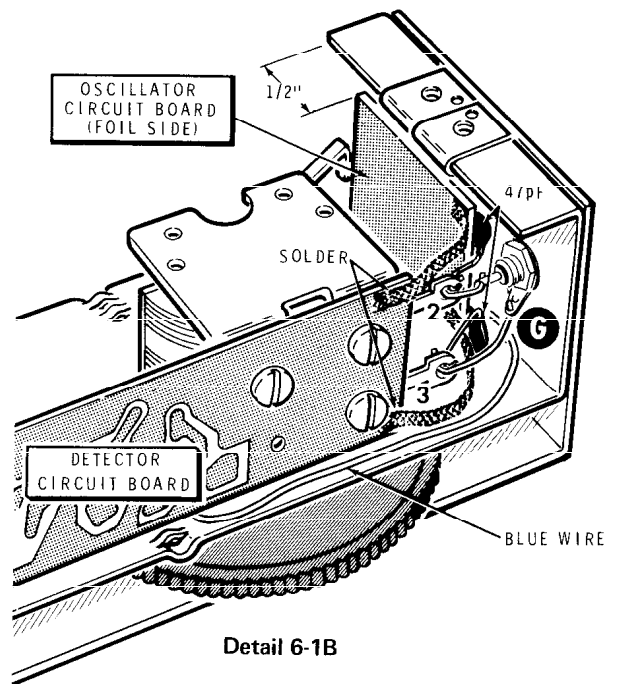

Detail 6-1B

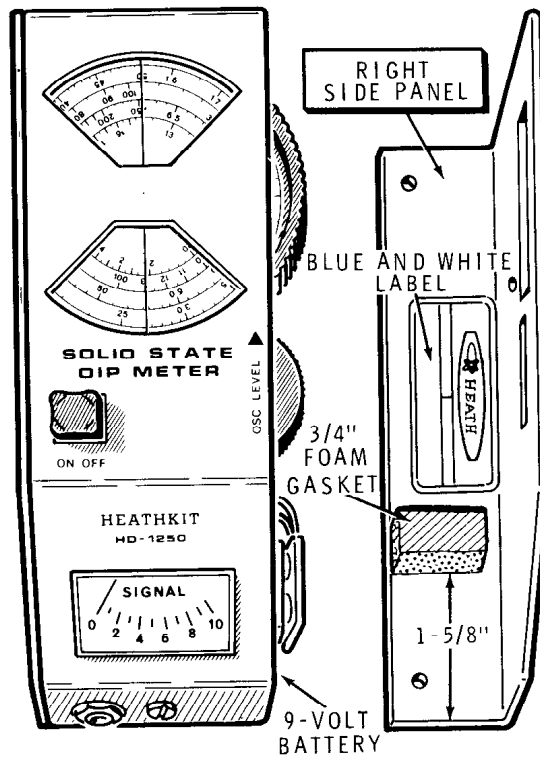

PICTORIAL 7-1

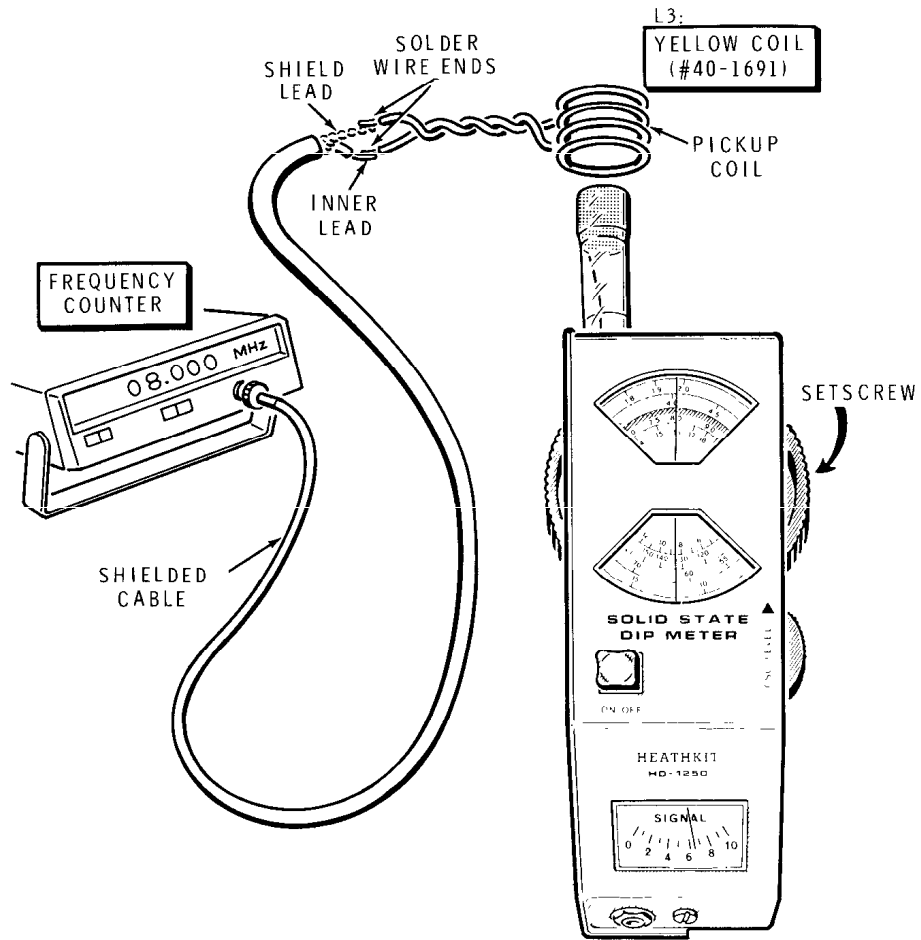
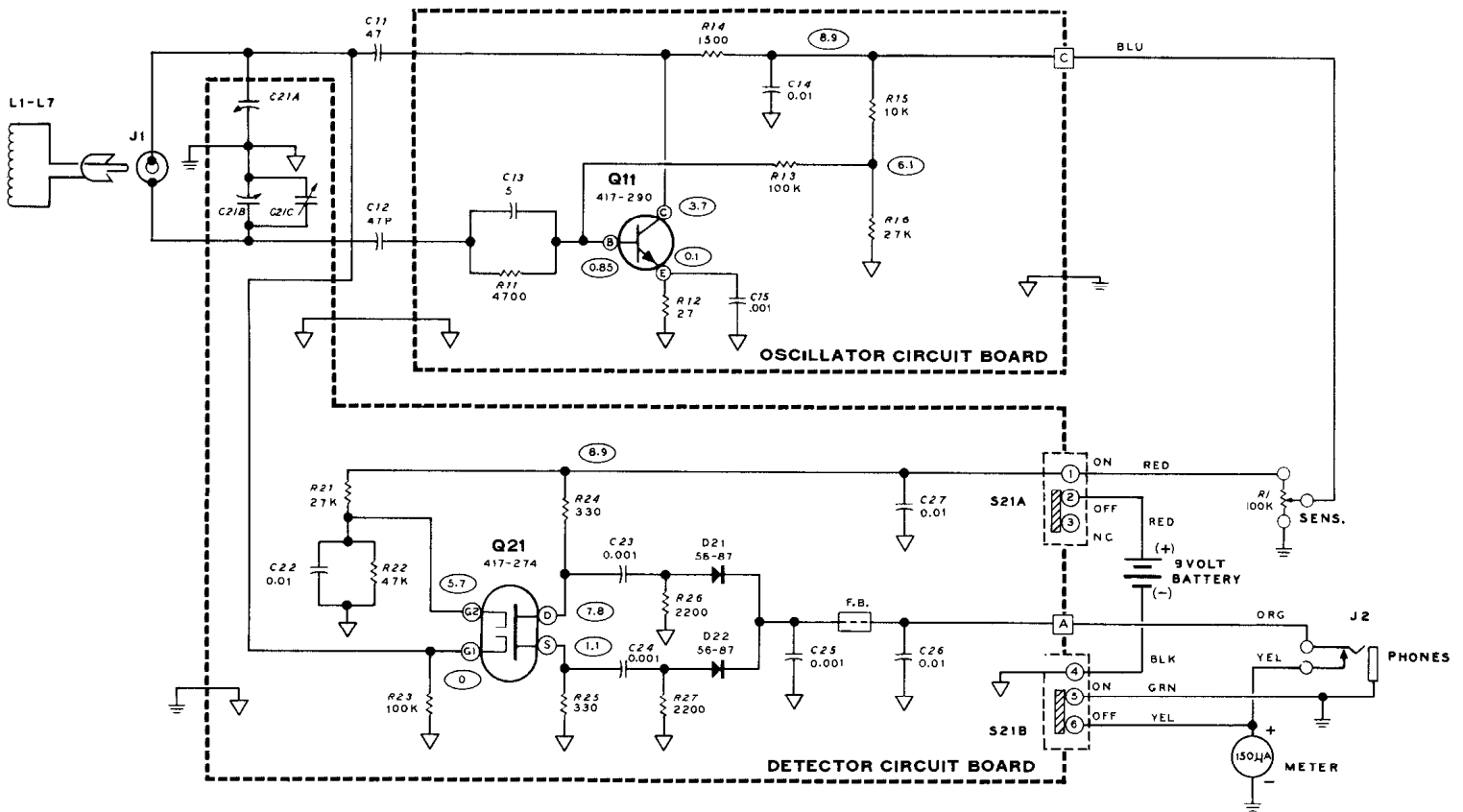

Figure 1-3



SCHEMATIC OF THE
HEATHKIT®
SOLID-STATE DIP METER
MODEL HD-1250