

specifications

FOR THE

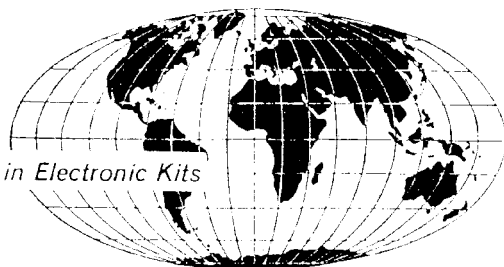

Pioneer And World-Leader in Electronic Kits



HAM-SCAN PANORAMIC ADAPTER

MODEL HO-13

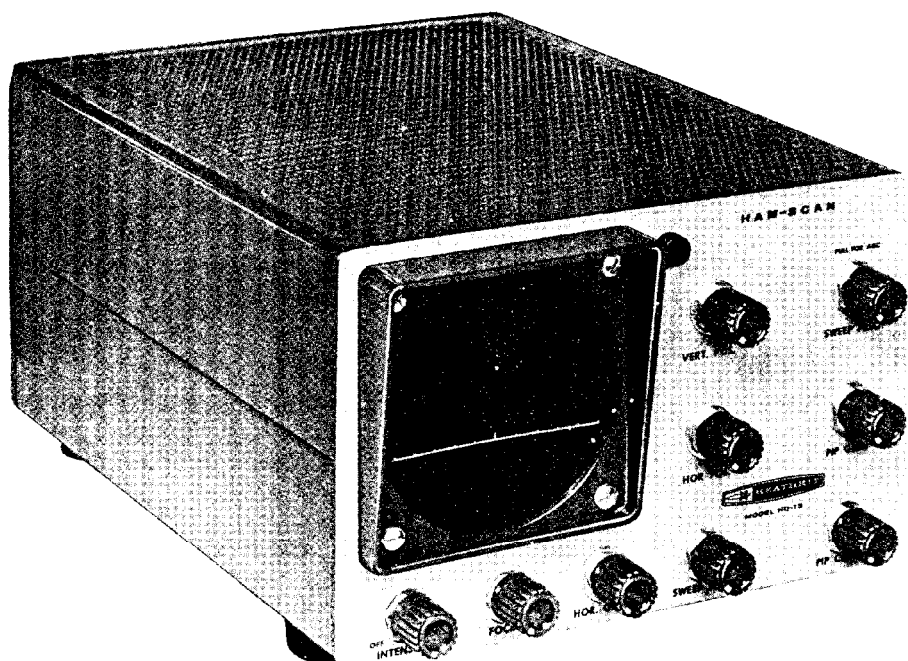

All prices are subject to change without notice.
The Heath Company reserves the right to discontinue instruments and to change specifications at any time.

HEATH COMPANY,
BENTON HARBOR, MICHIGAN

SPECIFICATIONS

RF AMPLIFIER

Input Frequencies (Receiver IF).....	One of the following: 455, 1600, 1650, 1681, 2075, 2215, 2445, 3000, 3055, 3395 kc.
Frequency Response.....	± 0.5 db at ± 50 kc from receiver IF.
Intermediate Frequency.....	350 kc.
Sensitivity.....	Approximately 50 μ v signal input level provides 1" vertical deflection at full gain setting.

HORIZONTAL DEFLECTION

Horizontal Sweep Generator.....	Recurrent type, linear sawtooth produced by internal sweep generator.
Sweep Frequency.....	10 to 50 cps, variable.
Sweep Width.....	30 kc, or less, to 100 kc $\pm 20\%$, continuously variable. (Approximately 15 kc to 100 kc for 455 kc IF.)
Resolution.....	2 kc (frequency difference between two 1" pips whose adjacent 3 db points coincide. Measured at slowest sweep speed and at 30 kc sweep width).

POWER SUPPLY

Type.....	Transformer operated, fused at 1/2 ampere.
Low Voltage.....	Full-wave voltage-doubler circuit, using four silicon diodes.
High Voltage.....	Half-wave circuit provides - 1500 volts for CRT.
Power Requirements.....	120 volts AC, 50/60 cps, 40 watts.

GENERAL

Tube And Diode Complement.....	1 - 3RP1 CRT, medium persistence green trace. 1 - 1V2 high voltage rectifier. 1 - 6AT6 detector. 1 - 6EW6 RF amplifier. 1 - 6C10 horizontal sweep generator, horizontal amplifier. 2 - 6EW6 IF amplifier. 4 - Silicon diode, low voltage rectifier. 1 - Crystal diode, voltage-variable capacitor. 1 - 6EA8 oscillator, mixer.
--------------------------------	--

Front Panel Controls.	On-Off/Intensity. Focus. Horizontal Gain. Sweep Width. Pip Center. Horizontal Position. Pip Gain. Vertical Position. Sweep Frequency/AGC.
Rear Control.	Astigmatism.
Dimensions.	5-1/4" high x 7-3/8" wide x 11" deep.
Net Weight.	8-1/2 lbs.
Shipping Weight.	11 lbs.

INTRODUCTION

The Heathkit Model HO-13 Ham-Scan Panoramic Adapter is designed for use with amateur and general coverage receivers. The Ham-Scan provides a visual display of signal amplitude versus frequency; the continuously variable frequency width is approximately 30 kc to 100 kc, centered on the receiver intermediate frequency. The signal being heard will appear as a pip at the center of the CRT screen. Pips to the right or left of the center of the screen are signals present in the IF passband of the receiver. Changing receiver tuning will move any one of these signal pips to the center of the CRT screen, at which time it will become audible. As the receiver is tuned, the signal pips move horizontally across the screen, with the signal being heard appearing at the center of the screen.

With the Ham-Scan it is possible to visually monitor the portion of the band which is centered on the frequency to which the receiver is tuned. Any clear frequency areas of a crowded amateur band or signals present in this area of the band can be seen. It is also possible to identify the type of transmission, SSB, AM, or CW.

The Ham-Scan can be used to provide a visual check for out-of-the-band operation when used in conjunction with a calibrator; to aid in searching for spurious transmitter radiation; and for carrier null adjustment of SSB transmitters. It may also be used for nulling the unwanted sideband of a phasing exciter.

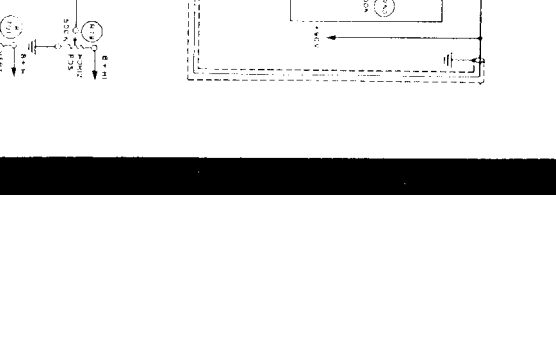
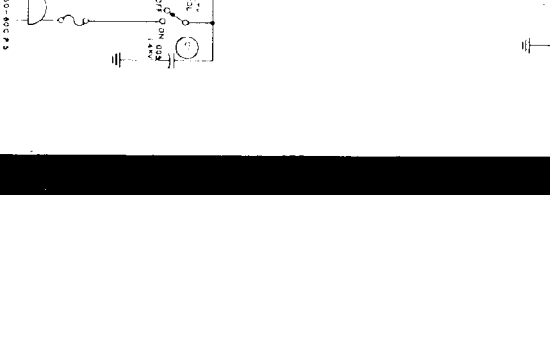
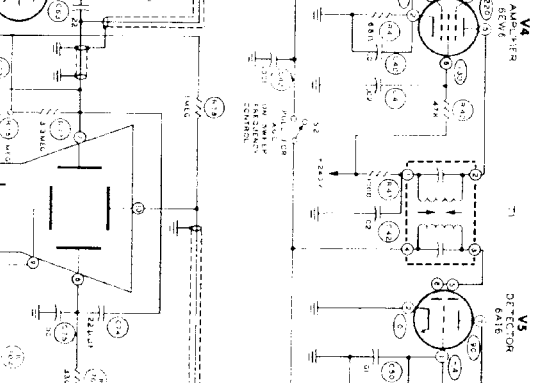
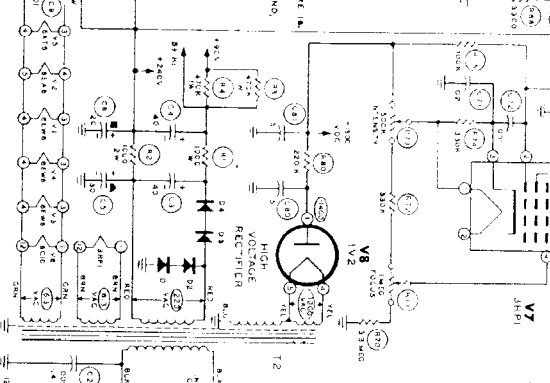
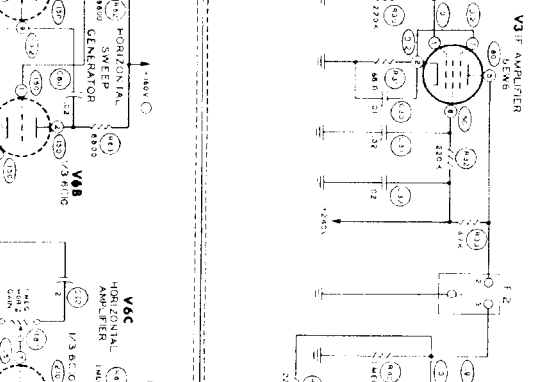
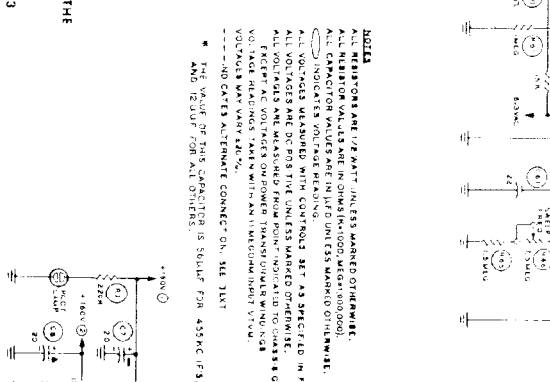
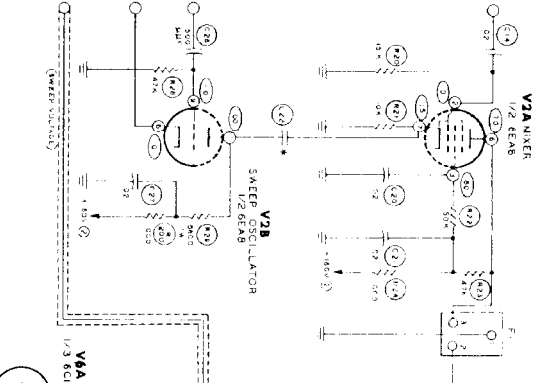
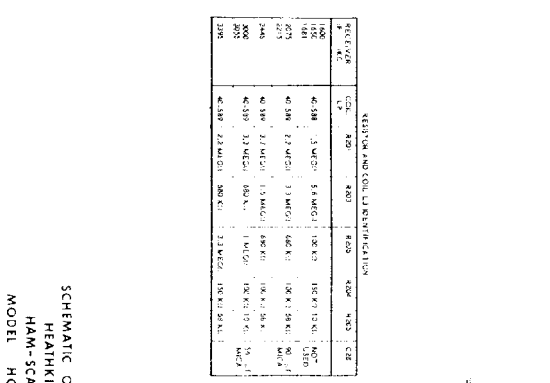
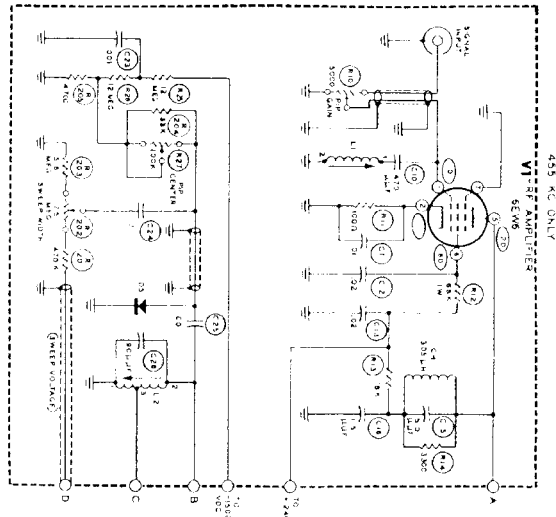
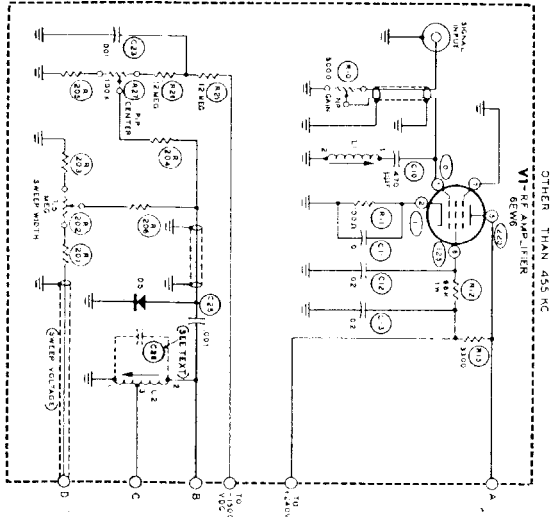

TUBE	TYPE	RESISTOR AND COIL IDENTIFICATION
6X4	6X4	10K, 100K, 1M, 5M, 10M, 50K, 100K, 1M, 5M, 10M, 50K, 100K, 1M, 5M, 10M
6AR5	6AR5	10K, 100K, 1M, 5M, 10M, 50K, 100K, 1M, 5M, 10M
6AV6	6AV6	10K, 100K, 1M, 5M, 10M, 50K, 100K, 1M, 5M, 10M
6BE6	6BE6	10K, 100K, 1M, 5M, 10M, 50K, 100K, 1M, 5M, 10M
6BD6	6BD6	10K, 100K, 1M, 5M, 10M, 50K, 100K, 1M, 5M, 10M
6BE7	6BE7	10K, 100K, 1M, 5M, 10M, 50K, 100K, 1M, 5M, 10M
6BE8	6BE8	10K, 100K, 1M, 5M, 10M, 50K, 100K, 1M, 5M, 10M
6BE9	6BE9	10K, 100K, 1M, 5M, 10M, 50K, 100K, 1M, 5M, 10M
6BE9A	6BE9A	10K, 100K, 1M, 5M, 10M, 50K, 100K, 1M, 5M, 10M
6BE9B	6BE9B	10K, 100K, 1M, 5M, 10M, 50K, 100K, 1M, 5M, 10M
6BE9C	6BE9C	10K, 100K, 1M, 5M, 10M, 50K, 100K, 1M, 5M, 10M
6BE9D	6BE9D	10K, 100K, 1M, 5M, 10M, 50K, 100K, 1M, 5M, 10M
6BE9E	6BE9E	10K, 100K, 1M, 5M, 10M, 50K, 100K, 1M, 5M, 10M
6BE9F	6BE9F	10K, 100K, 1M, 5M, 10M, 50K, 100K, 1M, 5M, 10M
6BE9G	6BE9G	10K, 100K, 1M, 5M, 10M, 50K, 100K, 1M, 5M, 10M
6BE9H	6BE9H	10K, 100K, 1M, 5M, 10M, 50K, 100K, 1M, 5M, 10M
6BE9I	6BE9I	10K, 100K, 1M, 5M, 10M, 50K, 100K, 1M, 5M, 10M
6BE9J	6BE9J	10K, 100K, 1M, 5M, 10M, 50K, 100K, 1M, 5M, 10M
6BE9K	6BE9K	10K, 100K, 1M, 5M, 10M, 50K, 100K, 1M, 5M, 10M
6BE9L	6BE9L	10K, 100K, 1M, 5M, 10M, 50K, 100K, 1M, 5M, 10M
6BE9M	6BE9M	10K, 100K, 1M, 5M, 10M, 50K, 100K, 1M, 5M, 10M
6BE9N	6BE9N	10K, 100K, 1M, 5M, 10M, 50K, 100K, 1M, 5M, 10M
6BE9O	6BE9O	10K, 100K, 1M, 5M, 10M, 50K, 100K, 1M, 5M, 10M
6BE9P	6BE9P	10K, 100K, 1M, 5M, 10M, 50K, 100K, 1M, 5M, 10M
6BE9Q	6BE9Q	10K, 100K, 1M, 5M, 10M, 50K, 100K, 1M, 5M, 10M
6BE9R	6BE9R	10K, 100K, 1M, 5M, 10M, 50K, 100K, 1M, 5M, 10M
6BE9S	6BE9S	10K, 100K, 1M, 5M, 10M, 50K, 100K, 1M, 5M, 10M
6BE9T	6BE9T	10K, 100K, 1M, 5M, 10M, 50K, 100K, 1M, 5M, 10M
6BE9U	6BE9U	10K, 100K, 1M, 5M, 10M, 50K, 100K, 1M, 5M, 10M
6BE9V	6BE9V	10K, 100K, 1M, 5M, 10M, 50K, 100K, 1M, 5M, 10M
6BE9W	6BE9W	10K, 100K, 1M, 5M, 10M, 50K, 100K, 1M, 5M, 10M
6BE9X	6BE9X	10K, 100K, 1M, 5M, 10M, 50K, 100K, 1M, 5M, 10M
6BE9Y	6BE9Y	10K, 100K, 1M, 5M, 10M, 50K, 100K, 1M, 5M, 10M
6BE9Z	6BE9Z	10K, 100K, 1M, 5M, 10M, 50K, 100K, 1M, 5M, 10M

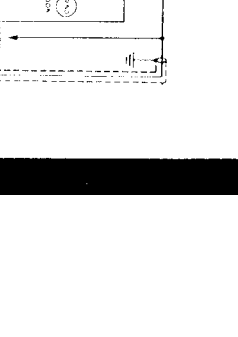
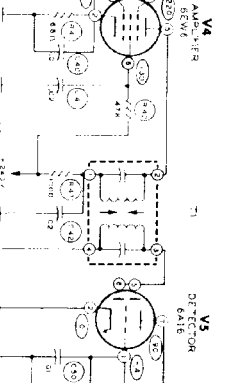
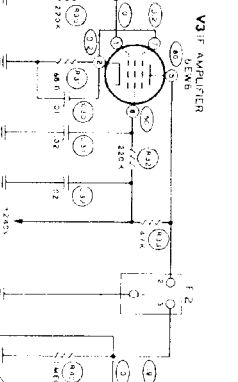
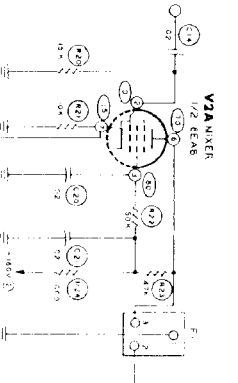
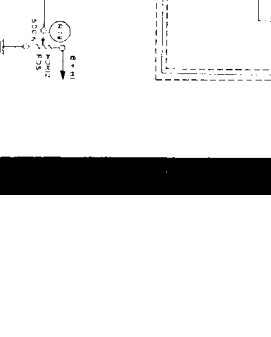
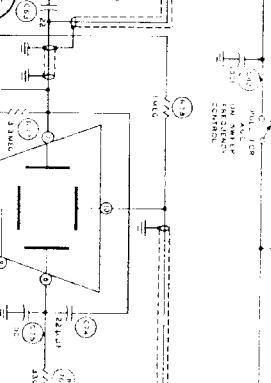
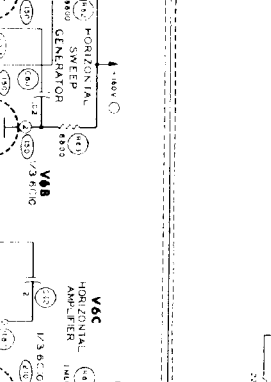

NOTE:
 ALL RESISTORS ARE 1/2 WATT UNLESS MARKED OTHERWISE.
 ALL CAPACITOR VALUES ARE IN OHMS UNLESS SPECIFIED OTHERWISE.
 ALL CAPACITOR VALUES ARE IN PFD UNLESS MARKED OTHERWISE.
 ALL INDICATED VALUES ARE IN OHMS UNLESS SPECIFIED IN FIGURE IN
 ALL OTHER CASES ARE IN MICROHMS UNLESS SPECIFIED OTHERWISE.
 ALL VOLTAGES ARE REFERRED TO THE COMMON POINT INDICATED TO COMMON GROUND.
 ALL VOLTAGES ARE MEASURED FROM POINT INDICATED TO COMMON GROUND.
 VOLTAGE RATINGS ARE IN WATTS UNLESS OTHERWISE SPECIFIED.
 VOLTAGE RATINGS ARE IN VOLTS UNLESS OTHERWISE SPECIFIED.
 * THE VALUE OF THIS CAPACITOR IS SCALF FOR 455KC F.S.
 AND IS USED FOR ALL OTHERS.

SCHEMATIC OF THE
 HEATHKIT
 HAM-SCAN
 MODEL HO-13

Assembly
and
Operation
of the



H A M - S C A N
P A N O R A M I C
A D A P T E R

M O D E L H O - 1 3

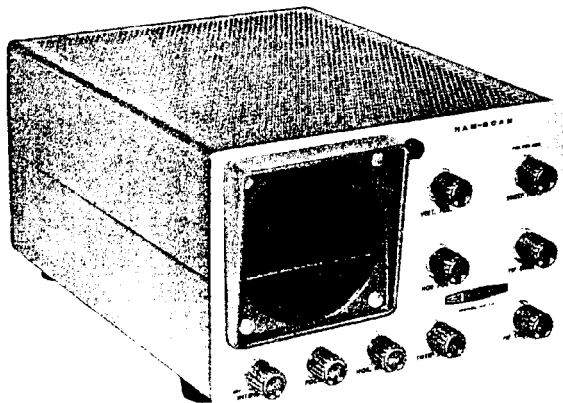

HEATH COMPANY,
BENTON HARBOR,
MICHIGAN

TABLE OF CONTENTS

Specifications	2
Introduction	3
General Circuit Description	4
Construction Notes	5
Parts List	6
Proper Soldering Techniques	8
Step-By-Step Procedure	9
Step-By-Step Assembly	
Chassis Parts Mounting	10
Front Panel Parts Mounting	14
Front Panel Wiring	16
CRT Mounting	20
Chassis Wiring	21
Alternate Front Panel Wiring	26
Chassis Component Wiring	28
Alternate Chassis Wiring	31
Final Wiring	34
Test And Adjustment	36
Final Assembly	42
Connection To Receiver	42
Operation	44
In Case Of Difficulty	49
Troubleshooting Chart	50
Circuit Description	52
Service Information	
Service	54
Replacements	55
Shipping Instructions	55
Schematic . . . (fold-out from page)	55
Warranty	56

SPECIFICATIONS

RF AMPLIFIER

Input Frequencies (Receiver IF).....	One of the following: 455, 1600, 1650, 1681, 2075, 2215, 2445, 3000, 3055, 3395 kc.
Frequency Response.....	± 0.5 db at ± 50 kc from receiver IF.
Intermediate Frequency.....	350 kc.
Sensitivity.....	Approximately 50 μ v signal input level provides 1" vertical deflection at full gain setting.

HORIZONTAL DEFLECTION

Horizontal Sweep Generator.....	Recurrent type, linear sawtooth produced by internal sweep generator.
Sweep Frequency.....	10 to 50 cps, variable.
Sweep Width.....	30 kc, or less, to 100 kc $\pm 20\%$, continuously variable. (Approximately 15 kc to 100 kc for 455 kc IF.)
Resolution.....	2 kc (frequency difference between two 1" pips whose adjacent 3 db points coincide. Measured at slowest sweep speed and at 30 kc sweep width).

POWER SUPPLY

Type.....	Transformer operated, fused at 1/2 ampere.
Low Voltage.....	Full-wave voltage-doubler circuit, using four silicon diodes.
High Voltage.....	Half-wave circuit provides - 1500 volts for CRT.
Power Requirements.....	120 volts AC, 50/60 cps, 40 watts.

GENERAL

Tube And Diode Complement.....	<ul style="list-style-type: none"> 1 - 3RP1 CRT, medium persistence green trace. 1 - 1V2 high voltage rectifier. 1 - 6AT6 detector. 1 - 6EW6 RF amplifier. 1 - 6C10 horizontal sweep generator, horizontal amplifier. 2 - 6EW6 IF amplifier. 4 - Silicon diode, low voltage rectifier. 1 - Silicon diode, voltage-variable capacitor. 1 - 6EA8 oscillator, mixer.
--------------------------------	--



Front Panel Controls.	On-Off/Intensity. Focus. Horizontal Gain. Sweep Width. Pip Center. Horizontal Position. Pip Gain. Vertical Position. Sweep Frequency/AGC.
Rear Control.	Astigmatism.
Dimensions.	5-1/4" high x 7-3/8" wide x 11" deep.
Net Weight.	8-1/2 lbs.
Shipping Weight.	11 lbs.

All prices are subject to change without notice. The Heath Company reserves the right to discontinue instruments and to change specifications at

any time without incurring any obligation to incorporate new features in instruments previously sold.

INTRODUCTION

The Heathkit Model HO-13 Ham-Scan Panoramic Adapter is designed for use with amateur and general coverage receivers. The Ham-Scan provides a visual display of signal amplitude versus frequency; the continuously variable frequency width is approximately 30 kc to 100 kc, centered on the receiver intermediate frequency. The signal being heard will appear as a pip at the center of the CRT screen. Pips to the right or left of the center of the screen are signals present in the IF passband of the receiver. Changing receiver tuning will move any one of these signal pips to the center of the CRT screen, at which time it will become audible. As the receiver is tuned, the signal pips move horizontally across the screen, with the signal being heard appearing at the center of the screen.

With the Ham-Scan it is possible to visually monitor the portion of the band which is centered on the frequency to which the receiver is tuned. Any clear frequency areas of a crowded amateur band or signals present in this area of the band can be seen. It is also possible to identify the type of transmission, SSB, AM, or CW.

The Ham-Scan can be used to provide a visual check for out-of-the-band operation when used in conjunction with a calibrator; to aid in searching for spurious transmitter radiation; and for carrier null adjustment of SSB transmitters. It may also be used for nulling the unwanted sideband of a phasing exciter.

GENERAL CIRCUIT DESCRIPTION

This brief circuit description is intended only to familiarize you with the Ham-Scan Panoramic Adapter. We suggest that you read this information before proceeding with assembly. A more detailed circuit description can be found on Page 52. You may want to study the detailed circuit description as time allows after assembly is completed. When reading this description, it may be helpful to follow the circuit on the Block Diagram and Schematic Diagram (fold-out from Page 55).

The input signal to the Ham-Scan is the intermediate frequency (IF) signal of the receiver used. This signal is amplified by radio frequency (RF) amplifier V1 and coupled to mixer V2A. The output of sweep oscillator V2B, which is essentially an FM signal modulated by the frequency of the sawtooth signal from horizontal amplifier V6C, is also coupled to mixer V2A. The output of mixer V2A is a 350 kc signal, amplitude modulated by the signal from the receiver IF circuit.

This 350 kc signal is applied through filter F1 to IF amplifier V3, where it is amplified and

then applied through filter F2 to IF amplifier V4. The 350 kc signal is amplified again and coupled through IF transformer T1 to the detector section of V5.

The detector of V5 demodulates the 350 kc IF signal and applies the detected signals to the amplifier section of V5. The detected signals are amplified and applied to the vertical plates of CRT V7 where they are displayed on the screen as "pips."

Sawtooth voltage from the multivibrator horizontal sweep generator section of V6 is coupled to the horizontal amplifier section of V6. Frequency is varied by the Sweep Frequency control; the amount of horizontal deflection is controlled by the Horizontal Gain control. The amount of bandwidth represented by the pattern on the CRT screen is determined by the amount of sawtooth voltage applied to diode D5 through the Sweep Width control. CRT V7 shows pips that represent the signals in and adjacent to the IF passband of the receiver. The pip for the signal being heard will appear at the center of the screen.

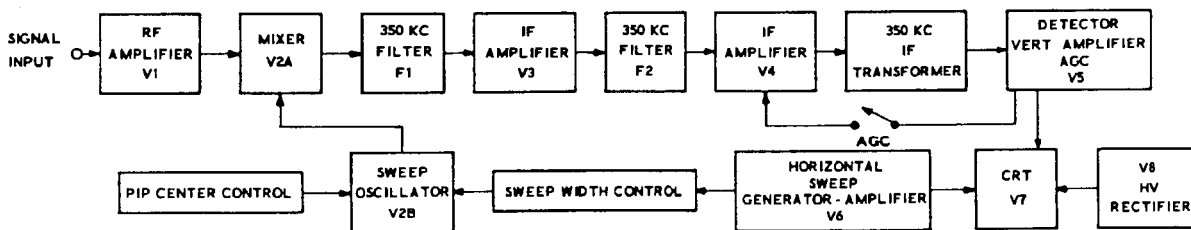

BLOCK DIAGRAM

PARTS LIST

The numbers in parentheses in the Parts List are keyed to the numbers on the Parts Pictorial to aid in parts identification.

PART No.	PARTS Per Kit	DESCRIPTION	PART No.	PARTS Per Kit	DESCRIPTION
RESISTORS (1/2 WATT)			RESISTOR (2 WATT)		
(1) 1-2	3	68 Ω (blue-gray-black)	(3) 1B-15	1	1000 Ω (brown-black-red)
1-3	1	100 Ω (brown-black-brown)	1B-3	1	10 KΩ (brown-black-orange)
1-9	3	1000 Ω (brown-black-red)	CONTROLS		
1-14	2	3300 Ω (orange-orange-red)	(4) 10-42	1	5000 Ω (5 KΩ)
1-16	1	4700 Ω (yellow-violet-red)	10-12	1	100 KΩ
1-19	2	6800 Ω (blue-gray-red)	10-26	2	500 KΩ
1-20	2	10 KΩ (brown-black-orange)	10-32	3	1 megohm
1-21	2	15 KΩ (brown-green-orange)	10-94	1	7.5 megohm
1-69	1	18 KΩ (brown-gray-orange)	(5) 19-78	1	500 KΩ with switch
1-24	1	33 KΩ (orange-orange-orange)	(6) 19-76	1	7.5 megohm with pull switch
1-25	5	47 KΩ (yellow-violet-orange)	CAPACITORS		
1-60	1	68 KΩ (blue-gray-orange)	(7) 20-52	1	7.5 μμf mica
1-26	3	100 KΩ (brown-black-yellow)	20-130	2	12 μμf mica
1-27	2	150 KΩ (brown-green-yellow)	20-99	1	22 μμf mica
1-29	5	220 KΩ (red-red-yellow)	20-78	2	56 μμf mica
1-31	3	330 KΩ (orange-orange-yellow)	20-119	1	90 μμf mica
1-33	1	470 KΩ (yellow-violet-yellow)	20-124	1	115 μμf mica
1-34	1	680 KΩ (blue-gray-yellow)	20-128	1	470 μμf mica
1-35	5	1 megohm (brown-black-green)	(8) 20-42	1	510 μμf mica
1-36	2	1.5 megohm (brown-green-green)	(9) 21-13	1	500 μμf disc
1-37	1	2.2 megohm (red-red-green)	21-14	7	.001 μfd disc
1-38	3	3.3 megohm (orange-orange-green)	21-90	1	.001 μfd disc (3 kv)
1-86	1	5.6 megohm (green-blue-green)	21-72	2	.005 μfd disc (1.4 kv)
1-120	2	12 megohm (brown-red-blue)	21-47	4	.01 μfd disc
			21-31	11	.02 μfd disc
			21-38	1	.02 μfd disc (1.6 kv)
			(10) 23-94	2	.15 μfd tubular
			(11) 23-49	2	.22 μfd tubular
			(12) 25-41	2	40 μfd 350 V electrolytic
			(13) 25-63	1	30-20-20-20 μfd 450-400-350-300 V electrolytic
			27-21	1	2 μfd molded
			27-25	1	.1 μfd Mylar
RESISTORS (1 WATT)			COILS-TRANSFORMERS-FILTERS		
(2) 1A-2	1	1000 Ω (brown-black-red)	(14) 40-588	1	Low frequency oscillator coil
1A-25	1	6800 Ω (blue-gray-red)	40-589	1	High frequency oscillator coil
1A-27	1	33 KΩ (orange-orange-orange)	(15) 40-590	1	350 kc trap coil
1A-8	1	68 KΩ (blue-gray-orange)	(16) 45-33	1	Choke
1A-32	2	470 KΩ (yellow-violet-yellow)	(17) 52-78	1	IF transformer
			54-130	1	Power transformer
			(18) 404-243	2	350 kc ceramic filter

PART No.	PARTS Per Kit	DESCRIPTION	PART No.	PARTS Per Kit	DESCRIPTION
<u>DIODES-TUBES-LAMPS-FUSE</u>			<u>TERMINAL STRIPS-SOCKETS-PLUG</u>		
19) 56-23	1	Voltage variable capacitor	(47) 431-15	1	1-lug terminal strip
		diode	(48) 431-25	2	1-lug terminal strip
20) 57-27	4	Silicon diode	(49) 431-14	1	2-lug terminal strip
411-10	1	6AT6 tube	(50) 431-16	1	2-lug terminal strip
411-65	1	1V2 tube	(51) 431-10	5	3-lug terminal strip
411-124	1	6EA8 tube	(52) 431-12	2	4-lug terminal strip
411-167	1	6C10 tube	(53) 431-45	2	6-lug terminal strip
411-170	3	6EW6 tube	(54) 431-35	1	7-lug terminal strip
411-142	1	3RP1 CR tube	(55) 434-34	4	7-pin tube socket
412-13	1	Neon panel lamp	(56) 434-56	2	9-pin tube socket
421-20	1	1/2 ampere slow-blow fuse	(57) 434-121	1	12-pin tube socket
			(58) 434-41	1	12-pin CRT socket
			(59) 434-107	1	Phono socket
			(60) 438-4	2	Phono plug
<u>HARDWARE</u>			<u>METAL PARTS</u>		
22) 250-49	19	3-48 x 1/4" screw	90-230	1	Cabinet
23) 250-172	6	3-48 x 3/8" screw	(61) 100-M329	1	CRT mounting ring
24) 250-56	14	6-32 x 1/4" screw	200-M401P25	1	Chassis plate
25) 250-89	10	6-32 x 3/8" screw	200-M402P27	1	Chassis enclosure
26) 250-48	2	6-32 x 1/2" screw	203-319P26	1	Front panel
27) 250-137	4	8-32 x 3/8" screw	(62) 206-180	1	CRT neck shield
28) 250-51	2	#10 x 3/8" sheet metal screw	(63) 206-258	1	CRT mu-metal shield
29) 252-1	25	3-48 nut	(64) 207-M1	2	CRT base clamp
30) 252-3	22	6-32 nut	210-20F	1	Bezel
31) 252-4	4	8-32 nut			
32) 252-7	14	Control nut			
33) 252-32	1	Push-on speednut			
34) 253-10	10	Control flat washer			
35) 253-40	6	Spring steel flat washer			
36) 254-7	27	#3 lockwasher			
37) 254-1	39	#6 lockwasher			
38) 254-2	5	#8 lockwasher			
39) 254-14	1	1/4" lockwasher			
40) 254-4	3	Control lockwasher			
41) 255-11	2	5/16" x 1" metal spacer			
42) 255-55	1	5/8" x 3/4" phenolic spacer			
43) 259-6	4	#6 solder lug, small	(65) 73-4	1	5/16" rubber grommet
44) 259-2	1	#8 solder lug	(66) 73-5	1	Rubber cushion strip
45) 259-10	2	Control solder lug	(67) 75-24	1	Line cord strain relief
46) 455-9	1	Brass control bushing	(68) 207-4	3	1/4" plastic clamp
			207-22	3	1/2" plastic clamp
			(69) 261-9	4	Rubber foot
			261-20	2	Rubber foot
			(70) 414-M9F995	1	Grid screen
			423-1	1	Fuseholder
			(71) 481-1	1	Capacitor mounting wafer
			462-168	10	Knob
			(72) 490-5	1	Nut starter
			(73) 205-254	1	Alignment tool blade
			331-6	1	Solder
			595-681	1	Manual
<u>WIRE-SLEEVING-SHIELDED CABLE</u>					
89-1	1	Line cord			
340-2	1	Bare wire			
344-58	1	Hookup wire			
344-13	1	High voltage hookup wire			
346-1	1	Sleeving			
343-5	1	RG-62U single-conductor shielded cable			
343-7	1	RG-174 single-conductor shielded cable			
347-19	1	3-conductor shielded cable			

PICTORIAL 18

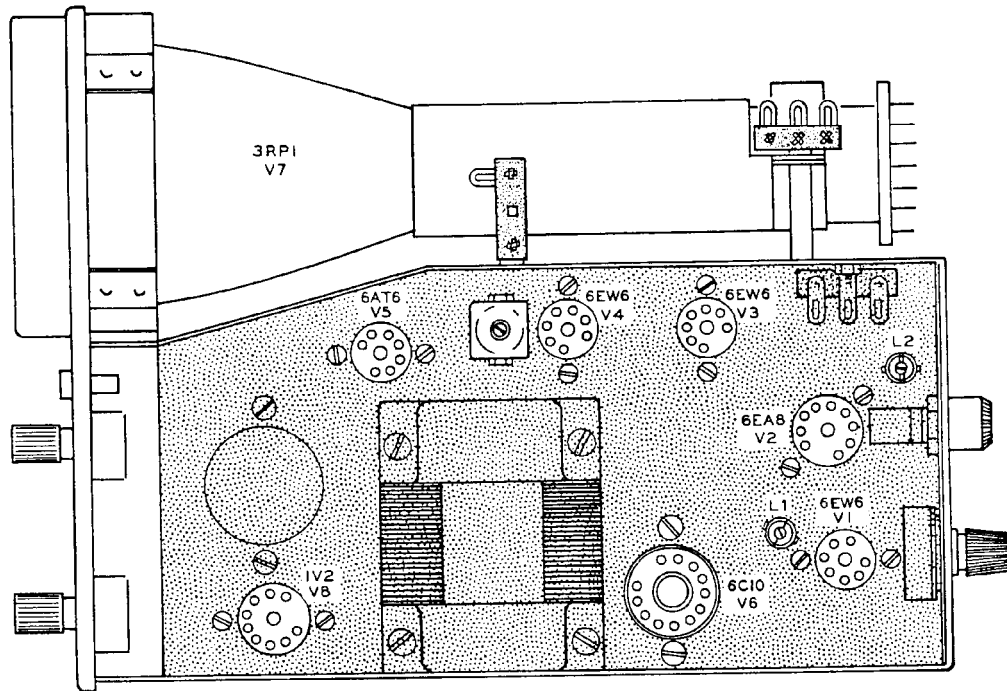

IMPORTANT: The remaining resistors, capacitors, and coil should be saved for use later in case you wish to connect the Ham-Scan to operate with another receiver with a different intermediate frequency.

clippings or bits of solder which might be lodged to the wiring.

This completes the wiring of the Ham Scan. Check all connections to be sure they are soldered correctly. Shake out any loose wire

Referring to Pictorial 18, install the tubes in their respective sockets. Observe care when inserting the tubes and do not bend the tube pins.

TEST AND ADJUSTMENT

INITIAL TEST

Use an ohmmeter to make the following tests before power is applied to the unit.

NOTE: Many ohmmeters do not have their test leads marked positive (+) and negative (-), or red (+) and black (-). If the ohmmeter test leads should be reversed during the following tests, the resistance reading will be approximately one-half of the value specified in the steps.

Refer to Figure 1 for the following steps.

- () Connect the negative (-) ohmmeter test lead to the chassis (ground).

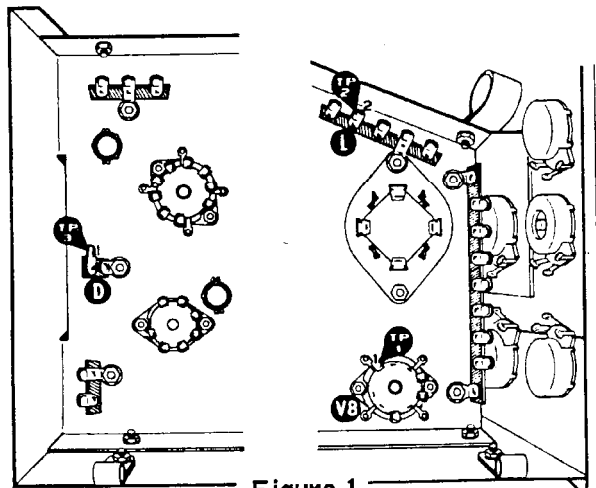

Figure 1

7-21 APR 18 1966



- () Connect the positive (+) ohmmeter test lead to lug 1 of socket V8 (TP-1). The resistance reading should be greater than 2 megohms after sufficient capacitor charging time.
- () Move the positive (+) ohmmeter test lead only to lug 2 of terminal strip L (TP-2). The resistance reading should be greater than 100 K Ω after sufficient capacitor charging time.
- () Connect the positive (+) ohmmeter test lead to lug 5 and the negative (-) test lead to lug 2 of terminal strip L. The resistance reading should be greater than 100 K Ω after allowing time for capacitor charging.

If these three tests are correct, proceed with the following steps. If difficulty is encountered, refer to the In Case Of Difficulty section on Page 49 of the manual.

CAUTION THE VOLTAGES IN THIS INSTRUMENT ARE DANGEROUS. Extreme care should be taken whenever this instrument is operated or handled when not installed in its cabinet. Extremely high voltages appear on the CRT socket, the INTENSITY control terminals, and the lugs of socket V8. These voltages could be lethal.

- () Before plugging the line cord into an AC outlet, preset the controls as follows:

INTENSITY - OFF.
 FOCUS - Center of rotation.
 HOR GAIN - Full counterclockwise.
 SWEEP WIDTH - Full counterclockwise.
 PIP CENTER - Full counterclockwise.
 PIP GAIN - Full counterclockwise.
 HOR POS - Center of rotation.
 VERT POS - Center of rotation.
 Sweep FREQ - Knob pushed in and turned full clockwise.
 ASTIG - Center of rotation.

- () Install a 1/2 ampere slow-blow fuse in the fuseholder.
- () Plug the line cord into a 120 volt 50/60 cps AC outlet.
- () Turn the INTENSITY control clockwise to approximately 3/4 of its rotation. This will apply power. The red neon pilot lamp and all tube filaments should glow, except in the 1V2 tube. This tube uses a filament

voltage of less than 1 volt and, for all practical purposes, there will be no glow. Allow one minute for the tubes to warm up.

- () Watch the center of the screen until a trace appears. If no trace appears, rotate both the HOR POS and the VERT POS knobs simultaneously until a trace is located. If a trace cannot be located, turn the unit off and refer to the In Case Of Difficulty section on Page 49.
- () Adjust the INTENSITY control until the trace is clearly visible, but not overly bright.
- () Adjust the FOCUS and ASTIG (on rear of unit) controls for the sharpest trace.
- () Adjust the HOR POS and VERT POS controls so the trace is positioned on the screen base line. Adjust the HOR GAIN control so the trace is the same length as the screen base line.
- () With the trace centered, slowly turn the HOR GAIN control clockwise. The trace should now become a dot on the screen base line. Now return the control to its full counterclockwise position.

If the trace is not perfectly horizontal, correct this condition as follows:

- () Observe the position of the trace on the CRT and estimate how far the CRT should be rotated. Turn off the power and pull the line cord plug.
- () Allow approximately 30 seconds for the filter capacitors to discharge. As an added safety precaution, use an insulated handle screwdriver and short lug 2 and lug 3 of terminal strip BM together to provide complete discharge.
- () Loosen the clamp at the base of the CRT and rotate the tube the proper amount by turning its socket. Do not allow the tube to slide forward and come into contact with the grid screen.
- () Plug in the line cord, turn on the unit and observe the trace.

This process should be repeated if the trace is still slightly tilted. When finished, carefully tighten the CRT base clamp to hold the tube in position.

- () Supplied with the kit is a small rectangular steel blade. Referring to the following Detail and using a pair of long-nose pliers, insert the blade into the smaller diameter hole of the plastic nut starter until the blade end is flush with the end of the nut starter. This now can be used as an alignment tool.

CONVERTING A NUT STARTER
TO AN ALIGNMENT TOOL.

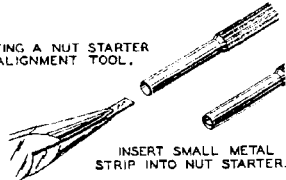

NOTE: There are two methods for adjustment of the Ham-Scan. If test instruments are available, perform the steps under Method I. If test instruments are not available, follow the steps under Method II.

METHOD I - WITH INSTRUMENTS

SETTING THE 350 KC TRAP COIL

NOTE: A calibrated signal generator with adjustable output control, capable of producing an accurate signal at 350 kc is necessary for the following adjustment.

- () Connect the RF output connector of the signal generator to the Signal Input jack of the Ham-Scan. An extra phono plug is provided for making this connection.
- () Turn on the signal generator and tune the generator to exactly 350 kc.
- () Turn on the Ham-Scan and preset the front panel controls as follows:
- INTENSITY - Clear trace on CRT.
 FOCUS - Sharpest trace.
 HOR GAIN - Full counterclockwise rotation.
 SWEEP WIDTH - Full counterclockwise rotation.
 HOR POS - Position trace to fill base line width.
 VERT POS - Position trace on screen base line.
 SWEEP FREQ - Full counterclockwise.
 AGC - Pushed in.
 PIP GAIN - Full clockwise.
 PIP CENTER - Center of rotation.

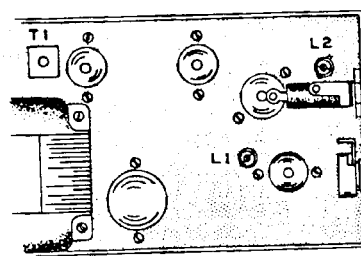

Figure 2

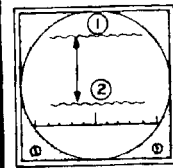

Figure 3

- () Turn up the signal generator output control, then tune the generator to first one side then the other of the 350 kc mark. The CRT trace will jump abruptly when the signal generator frequency is set at exactly 350 kc.
- () Carefully tune the signal generator (around the 350 kc mark) to the point where the CRT trace moves as far above the screen base line as it will go as shown at 1 of Figure 3. Turn the PIP GAIN control counterclockwise if the CRT trace has moved upward and completely off the CRT screen.
- () Using a small screwdriver or prepared alignment tool, adjust the slug of L1 until the CRT trace moves down toward the screen base line. The correct adjustment of L1 is at the point where the CRT trace moves the closest to the screen base line. See 2 of Figure 3.
- () If the PIP GAIN control is at the full clockwise position, increase the signal generator output and repeat the preceding two steps to make sure the CRT trace is positioned as near as possible to the screen base line.
- () Turn off the signal generator but do not disconnect it from the Ham-Scan at this time.

PIP ADJUSTMENT

NOTE: A DC voltmeter, preferably a VTVM, and a signal generator capable of producing an RF signal at your receiver intermediate frequency is required for the following adjustments.

- () Set the SWEEP WIDTH control fully counterclockwise, the PIP GAIN control to the center of its rotation, and the SWEEP FREQ control to the 3 o'clock position. Set the Ham-Scan on its flat side with the front panel facing you.

NOTE: A 20,000 Ω /volt multi-meter or a VTVM can be used for the following adjustment. Set the meter to the 15 V or greater DC range.

- () Referring to Figure 1, connect the voltmeter test leads to read negative (-) voltage from TP-3 (lug 1 of terminal strip D) to chassis.
- () Referring to the IF Chart, Chart III (fold-out from Page 41), locate the bias voltage setting listed for your receiver IF. If the exact IF frequency is not listed, use the voltage for the frequency nearest the IF in your receiver.
- () Turn on the Ham-Scan and after about a minute of warm-up time, adjust the PIP CENTER control until the voltmeter indicates the specified bias voltage.

NOTE: This negative (-) bias voltage value represents the basic frequency setting for your receiver IF. The PIP CENTER control must not be turned during the following adjustments.
CAUTION High voltage is present on the ASTIG control on the rear of the chassis enclosure, and 120 volts AC is on the exposed lugs of the fuseholder.

- () Set the Ham-Scan in its normal upright position.
- () Turn the SWEEP FREQ control to approximately 9 o'clock.
- () Referring to Figure 2, use the prepared alignment tool to turn the slug of coil L2 counterclockwise until it is just snug.
- () Tune the signal generator to the exact frequency specified in the IF Frequency Chart for your receiver. Set the signal level to about 1 millivolt.

- () Turn the slug of coil L2 clockwise the number of turns specified in the IF Chart while watching the CRT screen. The number of turns listed in the chart is approximate. As the slug approaches this setting, the IF signal pip should start to move onto the CRT screen.

NOTE: Noise pulses, harmonics, and images of the signal generator frequency can cause false pips to appear on the CRT screen. Slowly tune the signal generator while watching the CRT screen. You may see one or more pips move across the screen which are not very high. When the IF signal pip appears, it will normally fill the screen in a vertical direction. Carefully observe this pattern and remember its shape and size. Then reset the signal generator to the exact frequency specified for your receiver. There will also be an image pip which will appear 350 kc above or below the correct pip.

- () Turn the slug of coil L2 clockwise until the IF signal pip is centered on the screen base line. If the top of the pip is off the screen at the top of the CRT, turn the PIP GAIN control counterclockwise until the complete pip pattern is visible. See Figure 4.

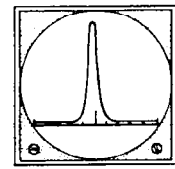

Figure 4

- () Adjust the PIP GAIN control until the IF signal pip is about 3/4" high.
- () Slowly tune the signal generator until the center of the signal pip is positioned at the left end of the screen base line. Record the signal generator frequency.
- () Slowly tune the signal generator until the center of the signal pip is centered at the right end of the screen base line. Record the signal generator frequency. The difference in frequency between these two pip positions will be about 100 kc.
- () Set the SWEEP WIDTH control fully clockwise and check the narrow width in the same manner.



NOTE: The powdered iron slugs in the top and bottom of Transformer T1 have been preset. However, a very slight adjustment may be necessary. Do not turn these slugs more than 1 turn in either direction from the original preset position.

- () Set the SWEEP WIDTH control for about 30 kc width.
- () Referring to Figure 2, use a small fiber screwdriver alignment tool and very carefully turn the slug at the top of T1 for maximum height of the IF signal pip.
- () Insert the fiber screwdriver in the bottom of T1 (from the underside of the chassis). Observe the IF signal pip and turn this slug carefully to obtain the most symmetrical pip shape. The correct setting for the two slugs of T1 is where the pip has the most symmetrical shape and the sharpest peak.

This completes the adjustment of the Ham-Scan with instruments. Unplug the line cord from the AC outlet and disconnect the signal generator.

METHOD II - WITHOUT INSTRUMENTS

The following procedure of aligning the Ham-Scan is recommended only if no test instruments are available. During the Pip Adjustment, it is necessary to use either a receiver with a crystal calibrator or a transmitter with a spotting signal available.

SETTING THE 350 KC TRAP COIL

- () Turn on the Ham-Scan and preset the controls as follows:

INTENSITY - Clear trace on CRT.

FOCUS - Sharpest trace.

HOR GAIN - Full counterclockwise rotation.

SWEEP WIDTH - Full counterclockwise rotation.

HOR POS - Position trace to fill base line width.

VERT POS - Position trace on screen base line.

SWEEP FREQ - Full counterclockwise.

PIP GAIN - Full counterclockwise.

PIP CENTER - Center of rotation.

- () Turn off the Ham-Scan.
- () Cut two 4" hookup wires. Remove 1/4" of insulation from one end of each wire.
- () Solder the stripped end of one wire to pin 6 of tube socket V5.
- () Solder the stripped end of the other wire to pin 1 of tube socket V1.
- () Twist the free ends of these wires together for about three turns.
- () Turn on the Ham-Scan and let it warm up.

NOTE: In this adjustment, a 350 kc signal will be generated within the Ham-Scan due to a feedback path (through the twisted wires) and the high gain IF strip. Oscillation will occur as the PIP GAIN control is advanced clockwise. The CRT trace will abruptly deflect vertically.

- () Advance the PIP GAIN control until the CRT trace deflects vertically. If the trace goes off the screen, reduce the PIP GAIN control setting until it reappears. If it is very difficult to keep the trace on the screen during oscillation, decrease the number of turns between the two twisted hookup wires.
- () Using the alignment tool, adjust the slug of L1 until the CRT trace starts to move down toward the screen base line. The correct adjustment of L1 is at the point where the CRT trace moves the closest to the screen base line.
- () Turn off the Ham-Scan and remove the two twisted wires from tube sockets V1 and V6.

PIP ADJUSTMENT

In the following adjustments it will be necessary to connect your receiver to the Ham-Scan. Refer to "Connection To Receiver" on Page 42 for instructions.

- () Referring to Figure 2 (Page 38), use the prepared alignment tool to turn the slug of coil L2 counterclockwise until it is snug.
- () Connect the cable from the receiver to the SIGNAL INPUT socket on the rear apron of the Ham-Scan.



- () Turn on the Ham-Scan and preset the controls as earlier for "Setting the 350 kc Trap Coil."
- () Disconnect any antenna from the receiver.
- () Tune in, on the receiver, either a calibrator signal, or the spotting signal from a transmitter, for maximum volume or S meter reading.
- () Turn the PIP GAIN control to 9 o'clock.

NOTE: It is very important that the pip corresponding to the received calibration or spotting signal be recognized so that proper adjustment can be made. Harmonics, images, and noise pulses can cause false pips to appear on the screen. During the next step you may see some of these false pips.

Whenever a pip appears on the screen it should be checked to see if it is the correct pip. First, turn the signal source off and on to make sure the pip is not from a stray source. Second, tune the receiver 5 or 10 kc either side of zero beat. Usually, if the pip corresponds to the signal being heard, the amplitude of the pip will be much higher off of zero beat. If the pip does not pass this second test, continue turning the slug of L2 until the correct pip has been found.

- () Turn the slug of coil L2 clockwise the number of turns specified in IF Chart III while watching the CRT screen. The number of turns listed in the chart is approximate. As the slug approaches this setting, the correct signal pip should start to move onto the screen.
- () If the correct pip has not been found at the approximate coil setting, rock the PIP CENTER control back and forth while turning the input signal off and on. It also may be necessary to increase the PIP GAIN control setting a small amount.
- () Adjust L2 until the signal pip is in the center of the screen. Adjust the PIP GAIN control until the pip is about 3/4" high.
- () Slowly tune the receiver until the center of the signal pip is positioned at the left end of the screen base line. Record the receiver frequency.

NOTE: If you are using the crystal calibrator method, it should be possible to now see another signal at the far right side of the screen. This signal is 100 kc away from the signal pip on the left of the screen.

- () Tune the receiver back until the signal pip is centered at the right end of the screen base line. Record the receiver frequency. The difference between these two pip positions will be about 100 kc.
- () Tune the signal back to the center of the base line. Slowly turn the SWEEP WIDTH control clockwise. Note that the pip will move to one side. Return it to the center with the PIP CENTER control. If the PIP CENTER control reaches its limit of rotation before the narrowest width is reached, adjust the slug of L2 to move the pip to the center.

NOTE: The powdered iron slugs in the top and bottom of Transformer T1 have been preset. However, a very slight adjustment may be necessary. Do not turn these slugs more than 1 turn in either direction from the original preset position.

- () Set the SWEEP WIDTH control for about 30 kc width.
- () Referring to Figure 2, use a small fiber screwdriver alignment tool and very carefully turn the slug at the top of T1 for maximum height of the IF signal pip.
- () Insert the fiber screwdriver in the bottom of T1 (from the underside of the chassis). Observe the IF signal pip and turn this slug carefully to obtain the most symmetrical pip shape. The correct setting for the two slugs of T1 is where the pip has the most symmetrical shape and the sharpest peak.
- () Continue the preceding adjustment until the pip can be centered with the PIP CENTER control for any setting of the SWEEP WIDTH control.

This completes the adjustment of the Ham-Scan without instruments. Unplug the line cord from the AC outlet.

12A
APR 17 1968

IF CHART III

RECEIVER IF	APPROXIMATE BIAS SETTING	L2 COIL NO.	APPROXIMATE COIL SETTING (SEE TEXT)
455 KC	-5 V	40-588	8 Turns
1600 KC	-14	40-588	10 Turns
1650 KC	-14	40-588	9 Turns
1681 KC	-15	40-588	9 Turns
2075 KC	-8	40-589	12 Turns
2215 KC	-6	40-589	5 Turns
2445 KC	-8	40-589	7 Turns
3000 KC	-9	40-589	6 Turns
3055 KC	-7	40-589	5 Turns
3395 KC	-9	40-589	5 Turns

RECEIVER IF CHART IV

MAKE	MODEL	IF	MAKE CONNECTION TO	COUPLING CAPACITOR C 17
HEATH	MR-1	3000 KC	Pin 6 of 6EA8 (mixer)	7.5 $\mu\mu f$
	GC-1A	455 KC	Collector of X2 (mixer)	12 $\mu\mu f$
	GR-91	455 KC	Pin 5 of V1 (12BE6)	12 $\mu\mu f$
	HR-10	1681 KC	Pin 6 of V2A (6EA8)	12 $\mu\mu f$
	HR-20	3000 KC	Pin 6 of V2A (6EA8)	7.5 $\mu\mu f$
	RX-1	1681 KC	Pin 5 of 6CS6 (1st mixer)	12 $\mu\mu f$
	SB-100	3395 KC	Pin 6 of V12A (2nd mixer)	7.5 $\mu\mu f$
	SB-300	3395 KC	Pin 5 of V3 (6AU6)	7.5 $\mu\mu f$
HALLICRAFTERS	SX-101A	1650 KC	Pin 5 of V2 (6BY6)	12 $\mu\mu f$
	SX-117	1650 KC	Pin 5 of 2nd mixer (6BE6)	12 $\mu\mu f$
	SX-100	1650 KC	Pin 5 of V2 (6AU6)	12 $\mu\mu f$
COLLINS	75S1, 75S2	455 KC	Pin 6 of V3A (6U8A)	12 $\mu\mu f$
	75S3	455 KC	Pin 6 of V4A	12 $\mu\mu f$
	75A Series	455 KC	Pin 9 of V5 (6BA7)	12 $\mu\mu f$
NATIONAL	NC-60	455 KC		12 $\mu\mu f$
HAMMERLUND	HQ-110	3035 KC	Pin 5 of V2	7.5 $\mu\mu f$
	HQ-180	3035 KC	Pin 5 of V2 (6BE6)	7.5 $\mu\mu f$
RME	6900	2195 KC	Pin 6 of V2 (6U8)	7.5 $\mu\mu f$
DRAKE	2A, 2B	445 KC	Pin 5 of V3 (6BE6)	12 $\mu\mu f$



- () Solder the shield lead of the connecting cable to a chassis ground near the IF connecting point. Use tape or insulating sleeving on the shield lead if there is any chance of a short circuit.

NOTE: We suggest you connect your receiver to the Ham-Scan and operate the units before reinstalling the receiver in its cabinet. If the cor-

rect connecting point has been made, tuning the receiver across the band should move the signal pips across the CRT screen.

- () Disconnect the receiver connecting cable from the Ham-Scan and install the receiver in its cabinet.

This completes the connecting procedure.

OPERATION

Set the Ham-Scan controls as follows, refer to Pictorial 20.

- INTENSITY - ON - and set for medium brightness.
 FOCUS and ASTIG - Sharpest possible overall trace.
 HOR GAIN - Full counterclockwise.
 SWEEP WIDTH - Full counterclockwise.
 PIP CENTER - Center of rotation.
 PIP GAIN - Full clockwise.
 SWEEP FREQ - Set for a stable pip of desired width.
 HOR POS - Trace centered on screen.
 VERT POS - Trace on screen base line.

These control positions are approximate and will change under normal operating conditions. Turn on your receiver and turn its RF gain control to maximum. Signal pips should appear along the screen base line indicating stations within the bandwidth being observed. Adjust the PIP CENTER control to position the signal being heard at the center of the screen base line. The SWEEP WIDTH control will normally affect the base line to some extent.

If your receiver has a crystal calibrator, turn it on and tune it in so it is audible. Turn the calibrator on and off several times while turning the PIP CENTER control and watching the CRT screen. Position the calibrator signal pip to the center of the screen base line with the PIP CENTER control.

If it should be impossible to center the calibrator signal pip with the PIP CENTER control, it can be assumed the signal generator used for the adjustment of L2 under Pip Adjustment was off calibration. Therefore, it will be necessary to readjust coil L2 to position the calibration signal pip to the center of the screen. Refer to either Method I or Method II for Pip Adjustment on Page 38 or 41.

False signals, "Birdies," may appear on the screen along with the signal pips. Birdies are usually receiver and Ham-Scan oscillator-mixer frequency products which fall in the band of frequencies being viewed. Some of their characteristics are:

1. Not audible when tuned to the center of the screen.
2. Move across the CRT screen at a different rate and/or direction than the audible signal pips.
3. Are narrower than the signal pips.
4. Will appear with no antenna connected to the receiver.
5. Still appear when the receiver RF gain control is at minimum.

The amount of AGC (or AVC) developed by different receivers varies considerably. In one receiver the AGC may only affect the amplitude of the pip of the signal being heard, with those pips either side of the audible pip remaining unchanged. In another receiver, the entire display will be affected. Generally, some level of AGC (in variable RF gain receivers) will be found to provide sufficient pip amplitude and normal AGC action of the receiver.

The overall frequency width displayed on the CRT can be checked at any time. Tune the receiver (or calibrating instrument) to move a specific signal pip from one end of the screen base line to the other end. The frequency difference between these two pip positions is the frequency width being displayed. The baseline can be calibrated by dividing this frequency width by 10 to indicate the approximate frequency difference between the individual calibration marks.

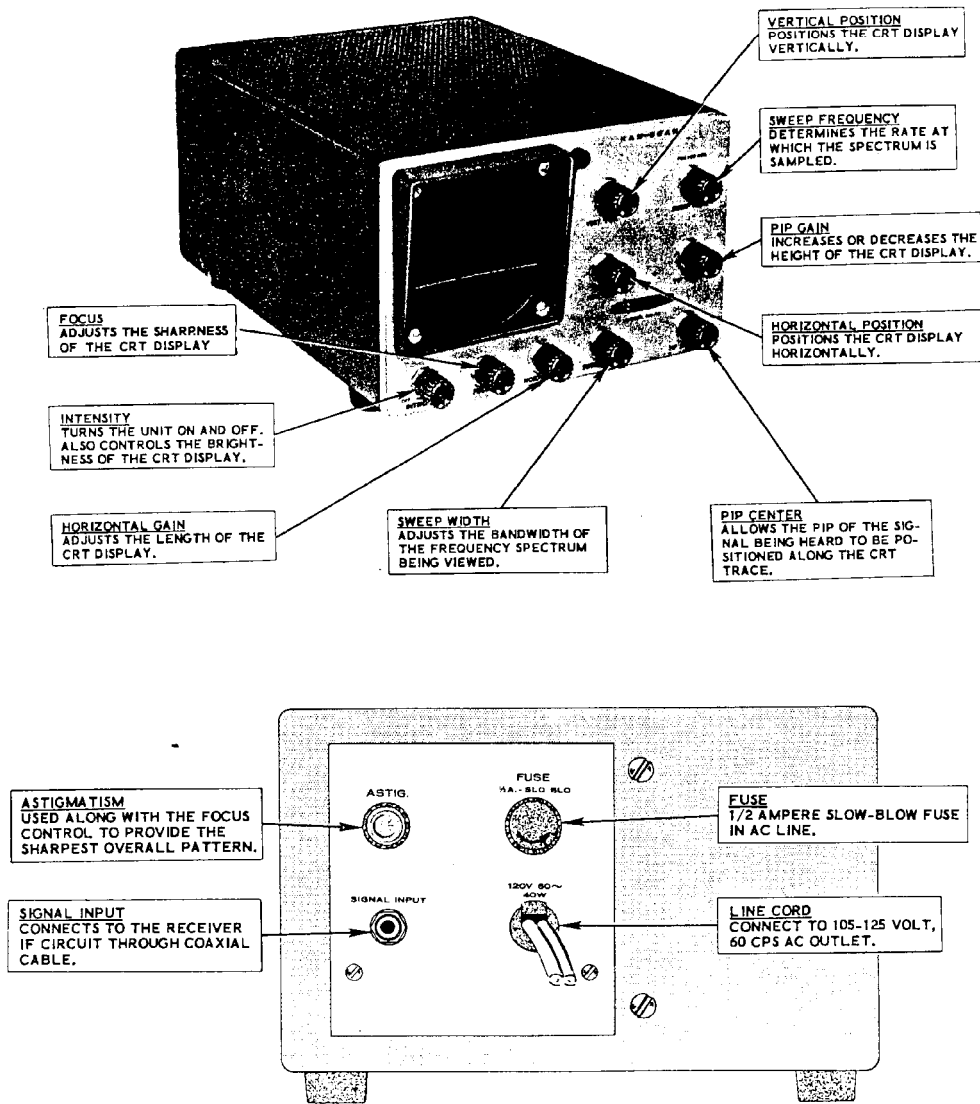

PICTORIAL 20

In this manner the approximate band width of the signal may be determined. When using a calibrating signal to mark the edges of the band any out-of-band operation can be seen. This will prove helpful when contacting DX stations whose operating frequency is outside of the United States amateur bands.

The Ham-Scan, when used with a general coverage receiver, will locate harmonics and/or spurious radiation from your transmitter. Use a dummy load on the transmitter and no (or very little) antenna on the receiver. Set the SWEEP WIDTH control of the Ham-Scan to maximum. Key the transmitter and tune the receiver while watching the CRT screen (listen to the receiver also) for spurious signals and harmonics.

For SSB transmitter carrier null adjustments, use the same setup mentioned above. Tune the receiver to the transmitter frequency. Use as narrow a sweep width as possible and null the carrier of a filter type SSB transmitter, or unwanted sideband of a phasing type SSB transmitter.

In receivers using transformer coupling between the mixer and amplifier stages, the passband response may fall off sharply either side of the center (IF) frequency. In receivers using crystal or mechanical filters after the mixer stage, the response is quite flat for ± 50 kc or more from the center frequency.

The amplitude of the signal pips will therefore depend upon the receiver passband response. When tuning a receiver having a crystal or mechanical filter, the amplitude of the signal

pip will decrease when it becomes audible. This is because the filter impedance becomes very low at the filter resonant frequency.

It is suggested that the IF frequency for which the Ham-Scan has been built be written on the rear apron for future reference.

IDENTIFYING CRT PATTERNS

If proper adjustments have been made as outlined in the Pip Adjustment section, the signal being heard from the receiver will appear at the center of the screen base line. CW, AM, RTTY, SSB, and electrical interference signals may be identified as shown in Figures 6 through 14. The width of the signal pip will depend on the setting of the Sweep Width control.

Figure 6 - Normal SSB: Since an SSB signal is only present during modulation, the pip will appear only when there is modulation present. The pip outline will also have peaks and valleys corresponding to the many voice frequencies.

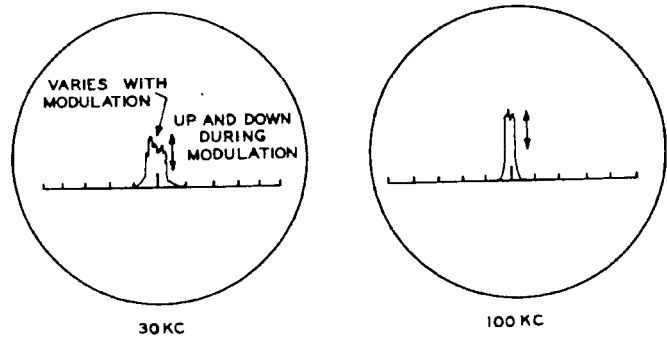

Figure 6

Figure 7 - Normal AM: Under no modulation the carrier will appear continuous. During modulation, the sides of the carrier will vary accordingly. These are the sidebands of an AM carrier.

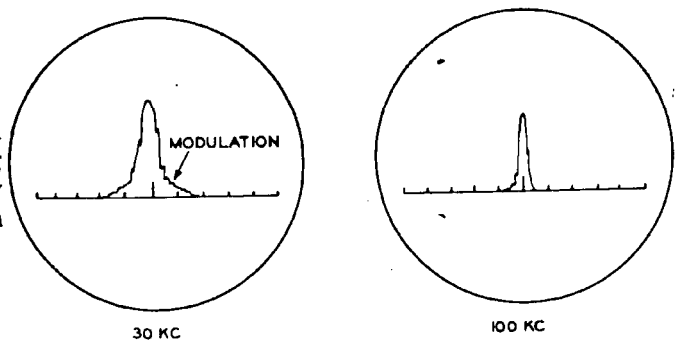

Figure 7

Figure 8 - CW: The pip of a CW signal will appear each time the transmitter is keyed. In the event of high speed CW, certain characters will not appear on the screen. This is due to the relatively slower sampling rate of the reactance modulator. In other words, a fast "dit" will appear in the receiver passband and disappear faster than all the signals in the passband are being sampled.

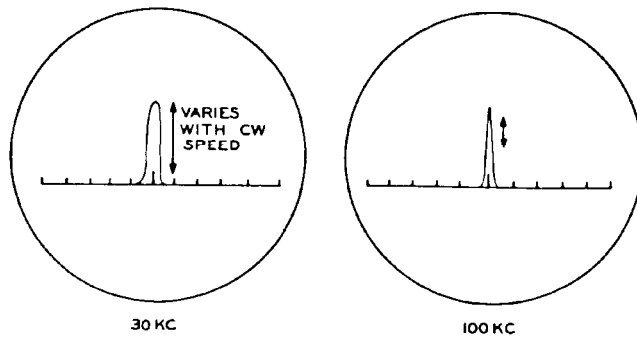

Figure 8

Figure 9 - Overmodulated AM: Very wide sidebands will appear with the carrier of an overmodulated AM signal. The approximate width can be measured by knowing the base line calibration.

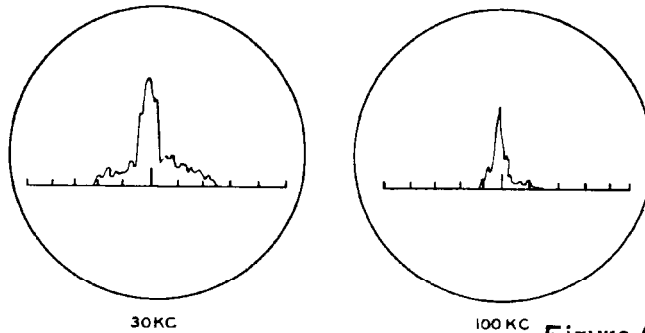

Figure 9

Figure 10 - Interfering AM Signals: The adjacent sidebands of two interfering AM signals will add and subtract giving the effect of a very wide AM signal with the center of the pip varying up and down. These two separate carriers may be seen if they are far enough apart in frequency.

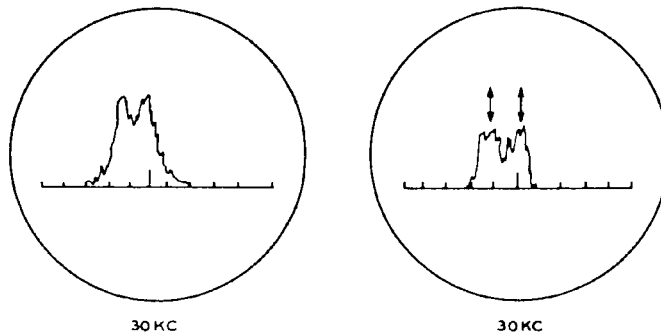

Figure 10

Interfering SSB signals - two interfering SSB signals will appear as a single, wide SSB signal with each half varying up and down at different rates.

Figure 11 - RTTY : Teletype signals will appear as an unmodulated carrier with a slight amount of sideways shift and, depending on the type of RTTY system, a certain amount of vertical shifting.

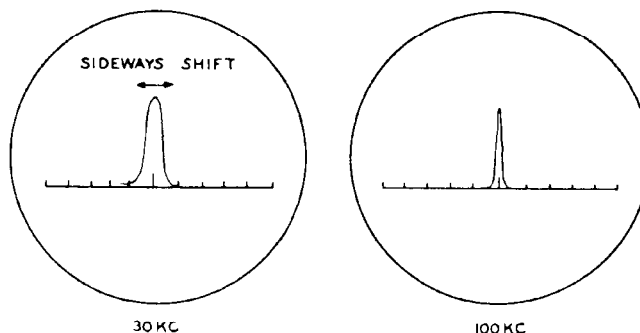

Figure 11

Figure 12 - Ignition Noise: Usually a series of sharp pulses that move back and forth or all in one direction.

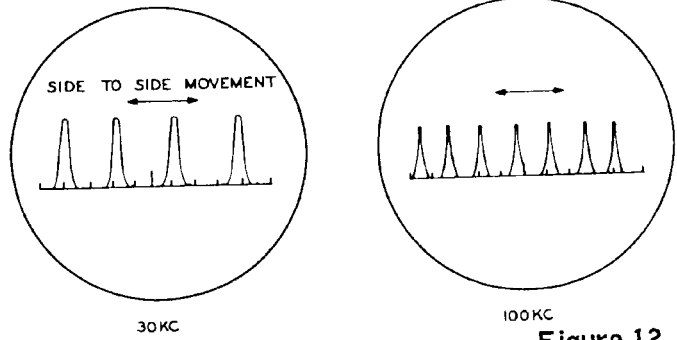

Figure 12

Figure 13 - Random Noise: This type of noise appears in numerous forms. Usually a noise pulse from electrical equipment, etc., is sharp and appears only briefly on the scope. A static burst is usually much wider, usually stationary on the screen, and lasts somewhat longer.

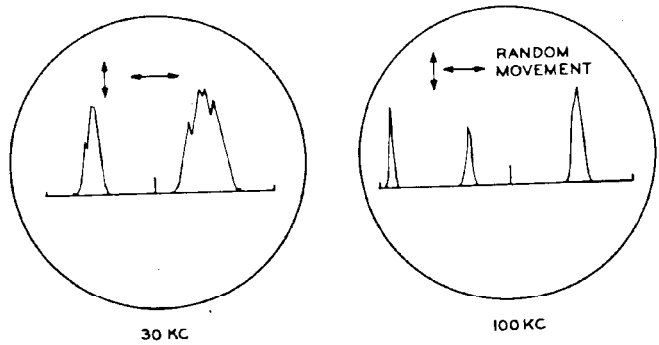

Figure 13

Figure 14 - Background Noise: This type of noise has the appearance of grass and is usually much lower in amplitude than the above types of noise. It gives a hissing sound in a speaker.

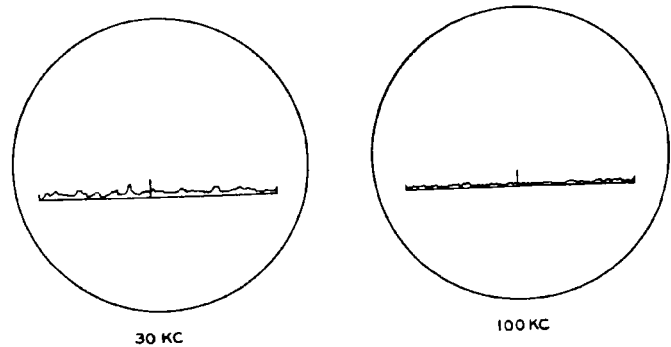

Figure 14

CIRCUIT DESCRIPTION

The following Circuit Description explains the Ham-Scan circuits which were covered only briefly in the General Circuit Description on Page 4. All circuit components mentioned in this description are shown on the Schematic Diagram.

SCHEMATIC DIAGRAM

The circled letter-number designations on the Schematic Diagram (fold-out from Page 55) are used to identify resistors, capacitors, coils, etc.

The first number of each designation refers to the tube circuit in which it is used. For example, the resistors in the circuit of tube V2 are marked R20, R21, R200, R201, etc., in tube circuit V7 they are marked R70, R71, R700, R701, etc. Designations in the B+ power supply circuit are marked C1, C2, R1, R2, etc.

The Schematic Diagram is divided into three sections. The upper left boxed-in area of the Schematic shows the circuit wiring of this section when the Ham-Scan is used with receivers having an intermediate frequency of 455 kc.

The lower left boxed-in area shows the circuit wiring of this section when the Ham-Scan is used with receivers having an intermediate frequency other than 455 kc.

Refer to the boxed in section which applies to your receiver's intermediate frequency. Both of these boxed-in areas connect to identical points in the third (common) section of the Schematic Diagram.

The Ham-Scan Panoramic Adapter is basically an electrically tuned receiver with a 350 kc intermediate frequency. The pattern of the received signal is displayed on a cathode ray tube. The RF input signal to the Ham-Scan is centered in the passband of the specific IF of the receiver to which the Ham-Scan is connected. These specific IF's range from 455 to 3395 kc.

RF AMPLIFIER

Input signals are taken from the receiver mixer plate and coupled to the grid of V1 in the Ham-Scan. The response of most receivers is usually

quite broad at the mixer plate. The band of frequencies to be viewed is centered on the receiver intermediate frequency. The signals in this band of frequencies are amplified by V1. The Pip Gain control R10 in the grid circuit of V1 controls the amount of signal applied, thereby controlling the height of the pip displayed on the CRT screen. Coil L1 and capacitor C10 comprise a trap circuit which effectively shorts out any 350 kc signal received from the receiver mixer.

A tuned circuit, CH1 and C15, is used only when the Ham-Scan is operated with receivers having an IF of 455 kc. The circuit is tuned to about 420 kc to restore the amplitude of the signal in this frequency area and compensate for any attenuation due to the 350 kc trap. Resistor R14 is added across the tuned circuit to lower the "Q". This resistor provides a more uniform pip amplitude in the band of frequencies between 405 and 455 kc.

SWEEP OSCILLATOR

The operating frequency of a sweep oscillator changes when an associated reactance is varied. Here, the frequency of V2B, a Hartley oscillator, is varied by changing the voltage across diode D5, which functions as a voltage-variable capacitor. Bias is applied to D5 through the Pip Center control. The capacitance of D5 at the negative bias setting, capacitor C28 (if used), and L2 determines the basic frequency of oscillation of V2B. A sawtooth voltage produced by V6A and V6B is coupled through capacitor C62 to the grid of V6C. This sawtooth voltage is amplified by V6C and coupled through C63 to the voltage divider network R201, R202, and R203. This sawtooth voltage is applied by the Sweep Width control R202, and capacitor C24 (for 455 kc operation) or resistor R206 (for other than 455 kc operation) to D5. The sawtooth voltage changes the capacitance of D5 which in turn varies the frequency of oscillation of V2B. The output of V2B is an RF signal modulated at a rate equal to the frequency of the sawtooth voltage. It is essentially a frequency modulated RF signal.

The sweep width is determined by the setting of the Sweep Width control R202, that is, the amount of sawtooth voltage applied to diode D5.

MIXER

The amplified receiver IF signal output at the plate of V1 is coupled through capacitor C14 to the grid of the mixer V2A. At the same time, the frequency-modulated output signal of V2B is coupled through capacitor C22 to the cathode of V2A. The plate circuit of V2A is tuned to 350 kc by filter F1. Each signal within the receiver IF passband is sampled each time the frequency difference between it and the reactance modulator output signal is 350 kc. The amount of bandwidth being observed is determined by the amount of sawtooth voltage applied to D5. The output of mixer V2A is a 350 kc signal amplitude modulated by the instantaneous amplitude of the signals present in the receiver IF passband.

IF AMPLIFIER

Two stages of IF amplification, V3 and V4, increase the amplitude of the 350 kc signal. Filters F1 and F2 increase the selectivity which results in a narrow pip with steep skirts. Switch S2 (pull switch on rear of Sweep Frequency control) functions as an automatic gain control (AGC) switch, decreasing the height of the strong signal pips but having little effect on the weaker signal pips.

DETECTOR

The amplified 350 kc signals are passed through IF transformer T1 to the diode plates of detector V5. The 350 kc signal is effectively shorted to ground by capacitor C50, leaving the detected signals present at the grid of the triode section of V5. The amplified signals appearing at the triode plate of V5 are applied directly to the vertical deflection circuit of the CRT.

HORIZONTAL SWEEP GENERATOR

The sweep generator consists of section V6A and V6B of the 6C10 triple triode compactron tube. These two sections of this tube operate as a free-running multivibrator sawtooth generator. The sweep frequency range can be varied by approximately 10 to 50 cps by adjusting Sweep Frequency control R66. R64 couples a small amount of 60 cps voltage to the cathode of V6A which synchronizes the sweep.

HORIZONTAL AMPLIFIER

Triode section V6C functions as a horizontal sweep amplifier. The sweep generator signal voltage output at the cathode of V6B is coupled through capacitor C62 to the grid of V6C. Horizontal Gain control R67 determines the amount of signal voltage coupled to the grid of V6C. The amplified sweep voltage at the plate of V6C is coupled through capacitor C63 directly to the horizontal deflection circuit of CRT V7. C63 also couples the sweep voltage to the voltage divider network of R201, R202, and R203 in the grid circuit of reactance modulator V2B.

POWER SUPPLY

The transformer-operated power supply provides AC filament power for tubes V1 through V7. The filament of the CRT V7 is powered by a separate 6.3 volt AC high voltage insulated winding on the power transformer. The -1500 volts DC required for the CRT is provided by the 1V2 high voltage rectifier through the capacitor-resistor filter network of C80, R80, and C81.

A full-wave voltage-doubler circuit provides B+ voltages. This circuit uses four silicon diodes D1 through D4. Resistors R1, R2, R5, R6, and capacitors C3 through C8 make up the B+ filtering network.

Resistors R3 and R4 are dropping resistors to provide a separate decoupled plate voltage for the triode section of detector V5.

