

HEATH COMPANY · BENTON HARBOR, MICHIGAN

H/R - 20

DAYSTROM
Overseas Ltd
ZÜRICH Badenerstrasse 333 Telephone (051) 52 88 80
GENEVE 13. rue Céard Telephone (022) 24 72 15

PRICE \$2.00

HEATHKIT® ASSEMBLY MANUAL

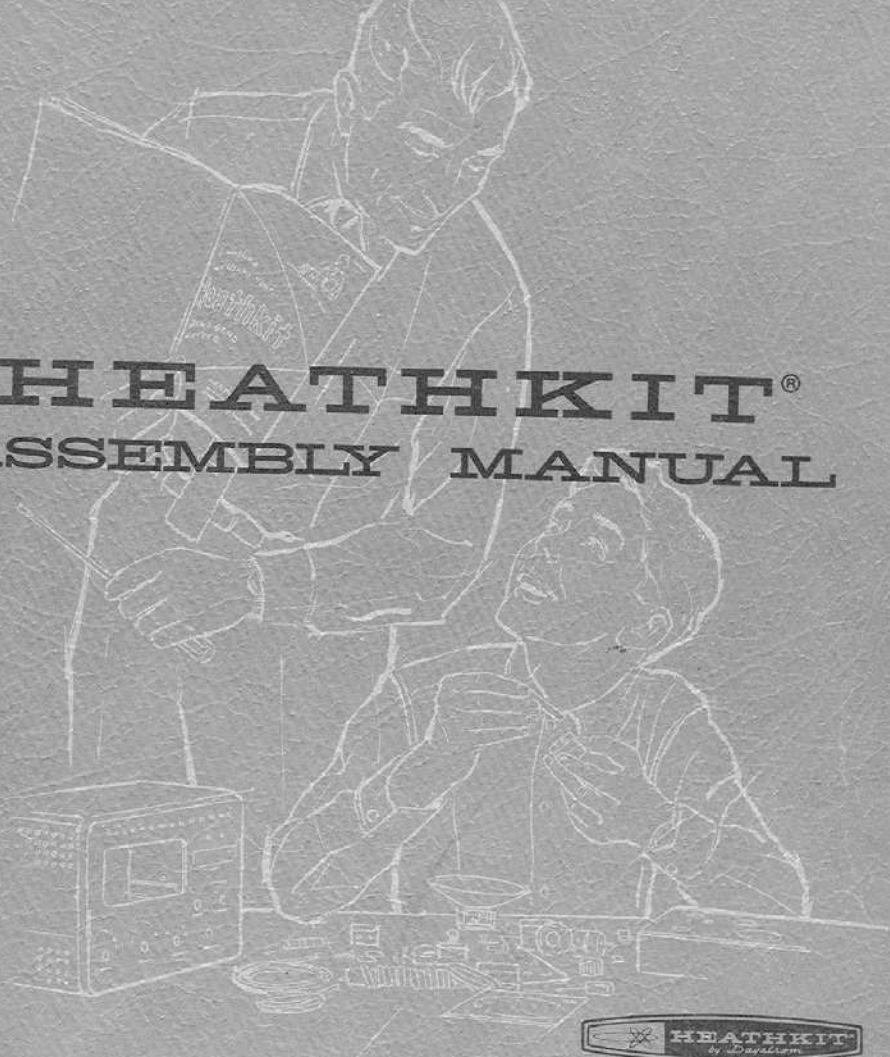

MOBILE RECEIVER
MODEL HR-20

RESISTOR AND CAPACITOR COLOR CODES

RESISTORS

The colored bands around the body of a color coded resistor represent its value in ohms. These colored bands are grouped toward one end of the resistor body. Starting with this end of the resistor, the first band represents the first digit of the resistance value; the second band represents the second digit; the third band represents the number by which the first two digits are multiplied. A fourth band of gold or silver represents a tolerance of $\pm 5\%$ or $\pm 10\%$ respectively. The absence of a fourth band indicates a tolerance of $\pm 20\%$.

The physical size of a composition resistor is related to wattage rating. Size increases progressively as the wattage rating is increased. The diameters of 1/2 watt, 1 watt and 2 watt resistors are approximately 1/8", 1/4" and 5/16" respectively.

The color code chart and examples which follow provide the information required to identify color coded resistors.

COLOR	CODE		MULTIPLIER
	1ST DIGIT	2ND DIGIT	
BLACK	0	0	1
BROWN	1	1	10
RED	2	2	100
ORANGE	3	3	1,000
YELLOW	4	4	10,000
GREEN	5	5	100,000
BLUE	6	6	1,000,000
VIOLET	7	7	10,000,000
GRAY	8	8	100,000,000
WHITE	9	9	1,000,000,000
GOLD	-	-	.1
SILVER	-	-	.01

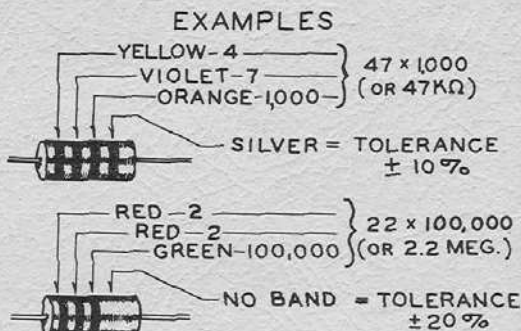
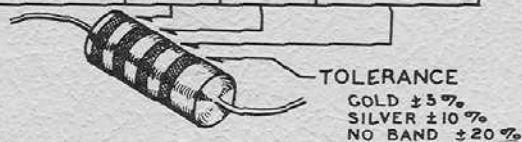

CAPACITORS

Generally, only mica and tubular ceramic capacitors, used in modern equipment, are color coded. The color codes differ somewhat among capacitor manufacturers, however the codes

shown below apply to practically all of the mica and tubular ceramic capacitors that are in common use. These codes comply with EIA (Electronics Industries Association) Standards.

MICA

COLOR	CODE		MULTIPLIER	TOLER. %
	1ST DIGIT	2ND DIGIT		
BLACK	0	0	1	± 20
BROWN	1	1	10	—
RED	2	2	100	± 2
ORANGE	3	3	1,000	± 3
YELLOW	4	4	10,000	—
GREEN	5	5	—	± 5
BLUE	6	6	—	—
VIOLET	7	7	—	—
GRAY	8	8	—	—
WHITE	9	9	—	—
GOLD	-	-	.1	—
SILVER	-	-	.01	± 10

EXAMPLE

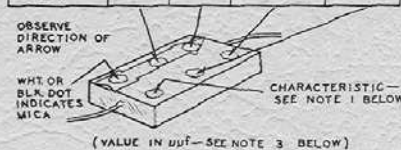
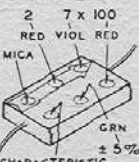

TUBULAR CERAMIC

Place the group of rings or dots to the left and read from left to right.

COLOR	CODE		MULTIPLIER	TOLER. %
	1ST DIGIT	2ND DIGIT		
BLACK	0	0	1	± 20
BROWN	1	1	10	± 0.1
RED	2	2	100	± 2
ORANGE	3	3	1,000	± 2.5
YELLOW	4	4	10,000	—
GREEN	5	5	—	± 0.5
BLUE	6	6	—	± 5
VIOLET	7	7	—	—
GRAY	8	8	—	± 0.25
WHITE	9	9	—	± 10

EXAMPLE

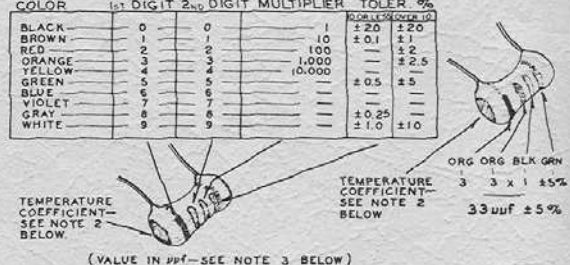

NOTES:

1. The characteristic of a mica capacitor is the temperature coefficient, drift capacitance and insulation resistance. This information is not usually needed to identify a capacitor but, if desired, it can be obtained by referring to EIA Standard, RS-153 (a Standard of Electronic Industries Association).

2. The temperature coefficient of a capacitor is the predictable change in capacitance with temperature change and is

expressed in parts per million per degree centigrade. Refer to EIA Standard, RS-198 (a Standard of Electronic Industries Association).

3. The farad is the basic unit of capacitance, however capacitor values are generally expressed in terms of μfd (microfarad, .000001 farad) and $\mu\mu\text{f}$ (micro-micro-farad, .000001 μfd); therefore, 1,000 $\mu\mu\text{f}$ = .001 μfd , 1,000,000 $\mu\mu\text{f}$ = 1 μfd .

USING A PLASTIC NUT STARTER

A plastic nut starter offers a convenient method of starting the most used sizes: 3/16" and 1/4" (3-48 and 6-32). When the correct end is pushed down over a nut, the pliable tool conforms to the shape of the nut and the nut is gently held while it is being picked up and started on the screw. The tool should only be used to start the nut.

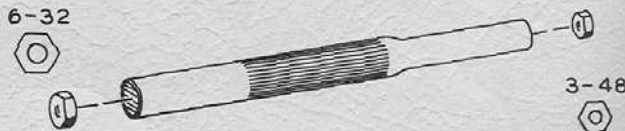

J.P. WAU...
626 de l'Ouest 3
2000 NEUCHÂTEAU

Assembly
and
Operation
of the



MOBILE
RECEIVER
MODEL HR-20



HEATH COMPANY,
BENTON HARBOR,
MICHIGAN

a subsidiary of
DAYSTROM, INCORPORATED

TABLE OF CONTENTS

Specifications	2
Introduction	3
Circuit Description	3
Construction Notes	5
Parts List	6
Proper Soldering Techniques	12
Schematic	13*
Step-By-Step Procedure	13
Step-By-Step Assembly	14
Initial Check	50
Adjustments	50
RF Alignment Chart	52
Cabinet Installation	52
Installation	53
Noise Suppression	54
Noise Troubleshooting Chart	57
Operation	58
In Case Of Difficulty	59
Troubleshooting Chart	60
Service Information	61
Warranty	64

*Fold-out from page.

All prices are subject to change without notice. The Heath Company reserves the right to discontinue instruments and to change specifications at any time without incurring any obligation to incorporate new features in instruments previously sold.

Copyright 1962
Heath Company

4/27/62



SPECIFICATIONS

Frequency Coverage.	80 Meters - 3.5 to 4.0 megacycles. 40 Meters - 7.0 to 7.3 megacycles. 20 Meters - 14.0 to 14.35 megacycles. 15 Meters - 21.0 to 21.5 megacycles. 10 Meters - 28.0 to 29.7 megacycles.
Intermediate Frequency.	3 megacycles.
IF Crystal Filter.	Mid-frequency - 3.0 megacycles. Bandwidth at -6 db - 3.0 kilocycles. Bandwidth at -60 db - 10.0 kilocycles maximum.
Sensitivity.	1 microvolt or less, at 10 db signal-to-noise ratio.
Panel Controls.	SB1-SB2 RF GAIN AF GAIN, power OFF CW/SSB-AM NOISE LIMITER OFF-ON AVC, OFF-FAST-SLOW Main Tuning BAND switch ANT TUNING
Rear Panel Connectors.	Antenna (ANT) 50-75 Ω . Power (PWR). Speaker (SPKR) 8 Ω . Earphones (PHONES) 500 Ω . FUSE
Meter.	Front panel "S" meter indicates received signal strength.
Tube Complement.	6BZ6 - RF amplifier. 6EA8 - Mixer-oscillator. 6BZ6 - First IF amplifier. 6EA8 - Second IF amplifier and "S" meter amplifier. 6BE6 - Product detector - BFO. 6BJ7 - AM detector - AVC - noise limiter. 6EB8 - First audio - audio output. OA-2 - Voltage regulator.
Power Requirements.	Filaments: 12 V at 2.5 amp AC or DC. 6 V at 5 amp AC or DC. B+ Voltage: 275-350 V DC at 85-125 ma. Total Power: 63.5 watts.
Cabinet Size.	6-1/8" high x 12-1/8" wide x 9-15/16" deep.
Net Weight.	16 lbs.
Shipping Weight.	19 lbs.

INTRODUCTION

The HEATHKIT Model HR-20 Mobile Receiver is designed to receive SSB, AM, and CW signals on the 80 through 10 meter amateur bands. Although this Receiver is intended primarily as a companion unit for the Model HX-20 Mobile Transmitter, equally good results may be obtained in fixed-station applications when the proper power supply and antenna are provided.

The 8-tube circuit of your superheterodyne Receiver has a basic sensitivity of less than one microvolt at a useable signal-to-noise ratio. A geared-down dial mechanism provides smooth, accurate tuning of the slide-rule scale for each band. Sharp selectivity and good image rejection are obtained in the 3 mc IF circuit by using a hermetically-sealed, lattice-type crystal filter. Also, an AVC-controlled "S" meter is provided on the front panel to indicate received signal strength.

There are connectors on the rear panel of the Receiver for a 50-75 Ω antenna, operating and control voltages, antenna relay, 8 Ω speaker, and earphones.

To avoid instability caused by power supply voltage variations, which are normal in mobile installations, a voltage regulator tube is used to regulate the B+ voltage input of critical circuits. On SSB, a crystal-controlled product detector is used for drift-free reception.

The following Block Diagram and Circuit Description will provide a better understanding of the Receiver. Since this knowledge will help the builder in the assembly of the Receiver, we strongly recommend that the Circuit Description be read thoroughly before proceeding.

CIRCUIT DESCRIPTION

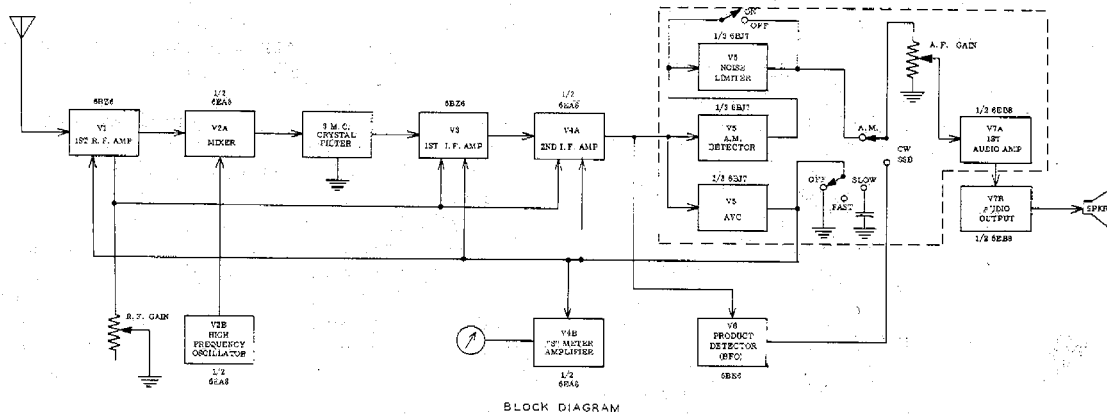

Refer to both the Block Diagram and the Schematic Diagram (Fold-out from Page 13) while reading the following description.

ANTENNA AND RF AMPLIFIER CIRCUITS

The antenna input circuit has five high Q coils. The correct coil for each band is selected by the BAND switch, and a resonant series trap suppresses any 3 mc signal from the antenna to eliminate signals leaking through at the IF

frequency. Variable capacitor C79 provides for tuning the antenna input to the operating frequency.

Signals from the antenna circuit are applied to high gain RF amplifier V1. The plate circuit of V1 is tuned to the operating frequency by capacitor C34A and the plate coil selected by the BAND switch. RF GAIN control R3, in the cathode circuit of V1, controls the amplification of this stage as well as that of IF amplifier



stages V3 and V4A. Also, fast or slow-acting AVC can be applied to V1, V3, and V4 to compensate for varying signal strength conditions.

OSCILLATOR AND MIXER

Triode tube section V2B, which is capacity coupled to the pentode mixer stage, is used as a high frequency oscillator. The five tuned oscillator coils and temperature compensating capacitors determine the frequency of oscillation. The proper coil for each band is selected by the BAND switch. Plate voltage for the oscillator is regulated by voltage regulator tube V8. All three groups of coils (antenna, mixer, and oscillator) are shielded from each other and located away from heat producing elements.

Pentode tube section V2A is used as a mixer stage. Signals from RF amplifier V1 and from oscillator V2B are mixed by V2A. Then the various frequencies that result from mixing are applied to the 3 mc IF crystal filter.

IF CRYSTAL FILTER

The 3 mc lattice-type crystal filter directly couples only the 3 mc output from the plate circuit of the mixer stage to the grid of first IF amplifier stage V3. Shielding for the input and output circuits of the hermetically sealed crystal filter is provided by the center section frame of the chassis base.

Bandpass characteristics of this filter are 3 kc at 6 db down, and 10 kc maximum at 60 db down. The top of this bandpass is essentially flat and the sides are very sharp. This gives the Receiver a high degree of selectivity.

FIRST IF AMPLIFIER STAGE

The first IF amplifier stage, V3, operates at 3 mc. Its gain can be varied by RF GAIN control R3. Fast or slow AVC may also be applied to this stage to obtain optimum performance. The plate circuit is tuned by 3 mc IF transformer T1. From here the signal is capacity coupled to the grid of the second IF amplifier stage.

SECOND IF AMPLIFIER AND "S" METER AMPLIFIER

The second IF amplifier, which uses pentode tube section V4A, is operated in the same manner as the first IF amplifier. Its gain is also varied

by RF GAIN control R3. The plate circuit is tuned by 3 mc IF transformer T2. From here the signal is capacity coupled to the AM detector through capacitor C59 and to the product detector through capacitor C69.

Triode tube section V4B is used solely as an "S" meter amplifier, which has a regulated B+ plate voltage supplied to it. The grid of this amplifier is driven by the AVC line voltage. Either of two different AVC filters may be selected by the OFF-FAST-SLOW AVC switch.

AM DETECTOR-AVC-NOISE LIMITING

V5, the triple diode used in this stage, provides the multiple functions of AM detection, AVC voltage rectification, and series type selectable noise limiting. Each of these functions may be selected as desired, including capacity coupling the AM detector output to the first audio amplifier stage.

PRODUCT DETECTOR STAGE

V6, the pentagrid converter, is used as a product detector and BFO. The IF signal is applied to its #3 grid. The #1 grid is part of a dual, crystal-controlled oscillator, corresponding to the upper and lower sidebands (SB1 and SB2).

The product detector mixes the IF and oscillator signals so that their resulting difference appears in the output as an audio frequency. If the two frequencies are nominally zero beat with each other, the oscillator portion replaces the missing carrier frequency for single sideband reception. If the two frequencies are separated by a frequency in the audible range, this results in the generation of an audible beat note for CW reception. This output may then be switched to the first audio amplifier stage.

FIRST AUDIO AND POWER OUTPUT AMPLIFIER

The amount of audio signal that is coupled from the detector stages to the first audio amplifier, V7A, is controlled by AF GAIN control R31. Audio amplifier V7A provides the necessary initial gain for the power output amplifier.

Pentode tube section V7B, the power amplifier, receives the amplified audio output of V7A and provides the audio power to output transformer T3.

Transformer T3 provides a 7500 Ω load for V7B and an 8 Ω secondary impedance for loud-speaker operation. An additional 500 Ω tap for headphone operation and transmitter anti-trip (when used) is also provided. The audio power output to an 8 Ω permanent-magnet speaker is rated at 3 watts.

VOLTAGE REGULATOR

Regulator tube V8 holds the voltage (over its normal current range of 4 to 30 ma) constant at +150 volts. This regulated +150 volts provides a stabilized voltage for the circuits that have

critical voltage requirements.

Filament voltage for RF Amplifier tube V1 and mixer-oscillator tube V2 is regulated on 12 volt DC operation. The voltage regulator provides stable operation during mobile use by eliminating filament voltage fluctuations caused by variations in generator output. Because a transistor is used in this circuit, the Receiver can be operated only on negative ground systems.

If the Receiver is used on a 6 volt DC voltage supply, the voltage regulator is bypassed, leaving the filaments of V1 and V2 unregulated.

CONSTRUCTION NOTES

This manual is supplied to assist you in every way to complete your kit with the least possible chance for error. The arrangement shown is the result of extensive experimentation and trial. If followed carefully, the result will be highly stable and dependable performance. We suggest that you retain the manual in your files for future reference, both in the use of the equipment and for its maintenance.

UNPACK THE KIT CAREFULLY AND CHECK EACH PART AGAINST THE PARTS LIST. In so doing, you will become acquainted with the parts. Refer to the information on the inside covers of the manual to help you identify the components. If some shortage or parts damage is found in checking the Parts List, please read the Replacements section and supply the information called for therein. Include all inspection slips in your letter to us.

Resistors generally have a tolerance rating of

10% unless otherwise stated in the Parts List. Tolerances on capacitors are generally even greater. Limits of +100% and -20% are common for electrolytic capacitors.

We suggest that you do the following before work is started:

1. Lay out all parts so that they are readily available.
2. Provide yourself with good quality tools. Basic tool requirements consist of a screwdriver with a 1/4" blade; a small screwdriver with a 1/8" blade; long-nose pliers; wire cutters, preferably separate diagonal cutters; a penknife or a tool for stripping insulation from wires; a soldering iron (or gun) and rosin core solder. A set of nut drivers and a nut starter, while not necessary, will aid extensively in construction of the kit.

Most kit builders find it helpful to separate the various parts into convenient categories. Muffin tins or molded egg cartons make convenient trays for small parts. Resistors and capacitors may be placed with their lead ends inserted in the edge of a piece of corrugated cardboard until they are needed. Values can be written on the cardboard next to each component. The illustration shows one method that may be used.

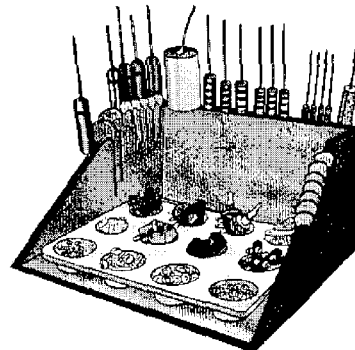



PARTS LIST

NOTE: The circled numbers in the Parts List are keyed to the circled numbers on the pictures of the parts to aid in parts identification.

<u>PART No.</u>	<u>PARTS Per Kit</u>	<u>DESCRIPTION</u>	<u>PART No.</u>	<u>PARTS Per Kit</u>	<u>DESCRIPTION</u>
Resistors			Capacitors		
① 1-3	1	100 Ω 1/2 watt (brown-black-brown)	④ 20-52	1	7.5 μf mica
1-45	5	220 Ω 1/2 watt (red-red-brown)	20-99	2	22 μf mica
1-4	1	330 Ω 1/2 watt (orange-orange-brown)	20-100	3	30 μf mica
1-9	3	1000 Ω 1/2 watt (brown-black-red)	20-97	9	50 μf mica
1-82	4	3600 Ω 1/2 watt (orange-blue-red)	20-119	1	90 μf mica
1-20	4	10 KΩ 1/2 watt (brown-black-orange)	20-102	5	100 μf mica
1-69	2	18 KΩ 1/2 watt (brown-gray-orange)	20-103	1	150 μf mica
1-24	1	33 KΩ 1/2 watt (orange-orange-orange)	20-105	1	180 μf mica
1-88	5	36 KΩ 1/2 watt (orange-blue-orange)	20-120	1	220 μf mica
1-25	2	47 KΩ 1/2 watt (yellow-violet-orange)	20-121	1	290 μf mica
1-102	1	82 KΩ 1/2 watt (gray-red-orange)	20-106	1	390 μf mica
1-26	1	100 KΩ 1/2 watt (brown-black-yellow)	20-107	1	680 μf mica
1-30	2	270 KΩ 1/2 watt (red-violet-yellow)	⑤ 21-33	1	3.3 μf disc ceramic
1-33	3	470 KΩ 1/2 watt (yellow-violet-yellow)	21-13	3	500 μf disc ceramic
1-34	2	680 KΩ 1/2 watt (blue-gray-yellow)	21-14	4	.001 μfd disc ceramic
1-35	2	1 megohm 1/2 watt (brown-black-green)	21-27	5	.005 μfd disc ceramic
1-37	1	2.2 megohm 1/2 watt (red-red-green)	21-16	16	.01 μfd disc ceramic
② 1A-43	1	51 Ω 1 watt (green-brown-black)	21-81	1	.1 μfd 50 V disc ceramic
1A-9	1	10 KΩ 1 watt (brown-black-orange)	⑥ 21-65	3	25 μf tubular ceramic (red-green-black)
③ 3G-21	1	4000 Ω 10 watt, wire-wound	21-66	2	50 μf tubular ceramic (green-black-black)
			⑦ 28-1	1	2.2 μf phenolic tubular
			⑧ 23-56	1	.5 μfd tubular
			⑨ 25-54	1	10 μfd 10 V tubular electro- lytic
			⑩ 25-16	1	20 μfd 350 V tubular electro- lytic
			⑪ 31-17	5	5-25 μf trimmer
			26-52	1	5-25 μf per section, 2-section variable
			⑫ 26-24	1	20 μf variable

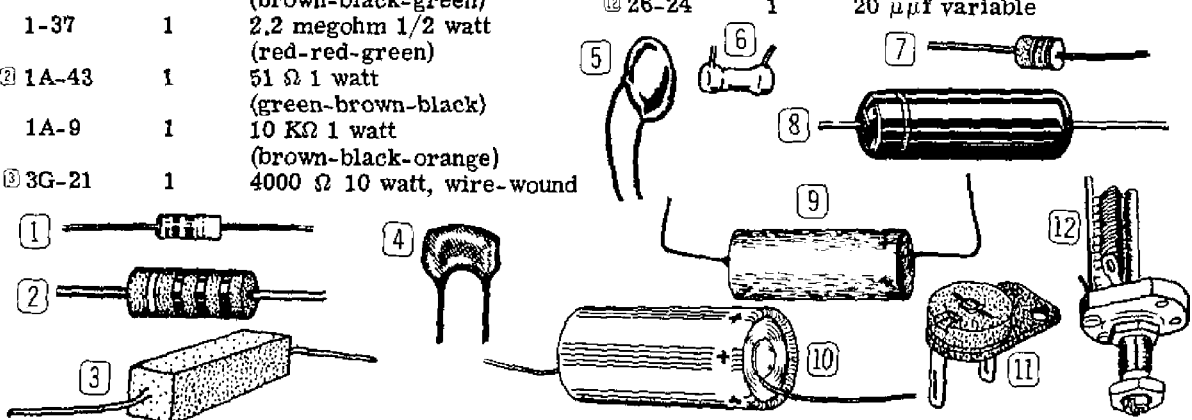

PART No.	PARTS Per Kit	DESCRIPTION
Coils-Chokes-Transformers		
51-84	1	Audio output transformer
52-25	2	IF transformer

Coil Set (#141-28)

Consisting of:

40-408	1	3 mc trap
① 40-454	1	80 meter antenna coil
40-455	1	40 meter antenna coil
40-456	1	20 meter antenna coil
40-457	1	15 meter antenna coil
40-458	1	10 meter antenna coil
40-459	1	80 meter mixer coil
40-460	1	40 meter mixer coil
40-461	1	20 meter mixer coil
40-462	1	15 meter mixer coil
40-463	1	10 meter mixer coil
40-464	1	80 meter oscillator coil
40-465	1	40 meter oscillator coil
40-466	1	20 meter oscillator coil
40-467	1	15 meter oscillator coil
40-468	1	10 meter oscillator coil
② 45-3	2	1 mh RF choke
③ 45-43	2	Parasitic choke

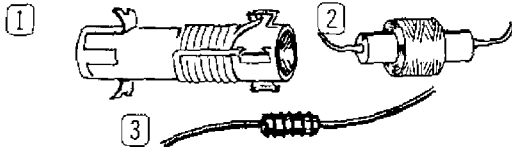

Switches-Controls-Knobs

④ 62-10	1	Function switch (2-position, spring detent)
63-193	1	BAND switch (5-position)
⑤ 63-177	1	Sideband switch (2-position)
⑥ 63-194	1	NL ON-OFF switch
⑦ 63-289	1	AVC switch (3-position)
10-131	1	10 KΩ RF GAIN control

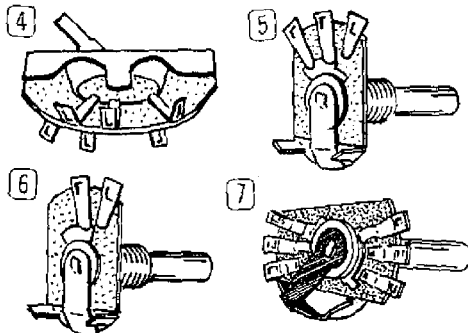

PART No.	PARTS Per Kit	DESCRIPTION
Switches-Controls-Knobs (cont'd.)		
⑧ 19-42	1	1 megohm AF GAIN control with DPST switch
⑨ 11-30	1	25 Ω control
⑩ 462-80	1	Plastic lever knob
462-158	1	1-3/4" aluminum knob
462-129	3	1-1/4" aluminum knob
462-130	3	9/16" aluminum knob
462-172	1	1-1/4" knurled aluminum knob

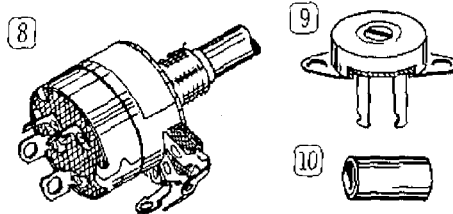

Tubes-Lamps-Crystals (filter)

⑪ 56-6	1	Zener diode
411-59	1	OA2 voltage regulator
411-91	1	6BE6 tube
411-113	1	6BJ7 tube
411-124	2	6EA8 tube
411-126	2	6BZ6 tube
411-161	1	6EB8 tube
412-14	3	#44 pilot lamp
404-12	1	3 mc crystal filter
404-182	1	2998,5 kc crystal
404-183	1	3001,5 kc crystal
417-30	1	Transistor

Terminal Strips-Sockets-Plugs

⑫ 431-49	6	11-lug terminal strip
⑬ 434-35	4	7-pin tube socket with shield base
434-36	4	9-pin tube socket with shield base
⑭ 434-118	1	11-pin socket

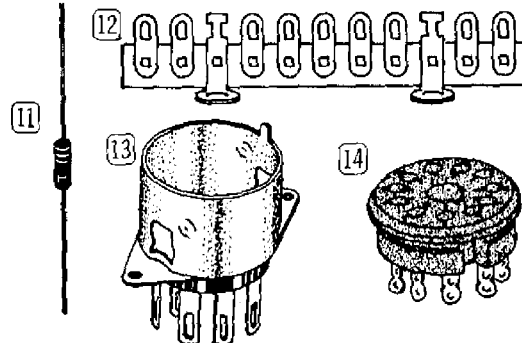



PART No.	PARTS Per Kit	DESCRIPTION
----------	---------------	-------------

Terminal Strips-Sockets-Plugs (cont'd.)

① 434-74	2	Crystal socket
② 434-88	3	Pilot lamp socket
③ 438-29	1	11-pin plug
④ 440-1	1	Plug cap
⑤ 434-42	2	Phono socket
⑥ 436-21	1	Phone jack

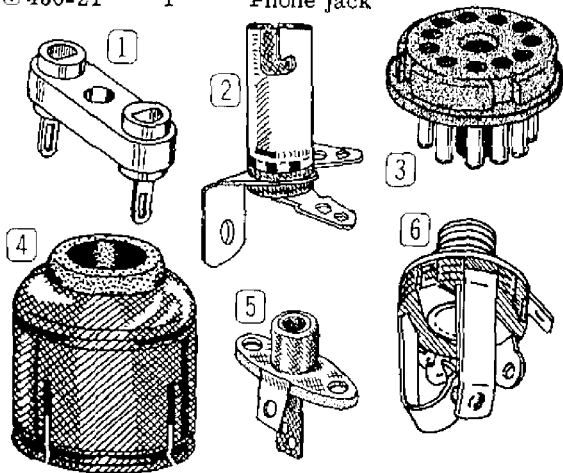

Wire-Cord-Sleeving

340-2	1	Length #20 bare wire (thin)
340-3	1	Length #16 bare wire (thick)
343-7	1	Length shielded wire
344-1	8	Lengths hookup wire: 1 each of the following: green, blue, red, brown, orange, black, white, yellow
346-1	1	Length sleeving
347-1	1	Length 8-conductor cable
349-3	1	Dial cord

Gears-Shafts-Bushings

⑦ 100-201	1	Pinion gear shaft assembly
⑧ 100-202	1	Pointer drive pulley shaft assembly

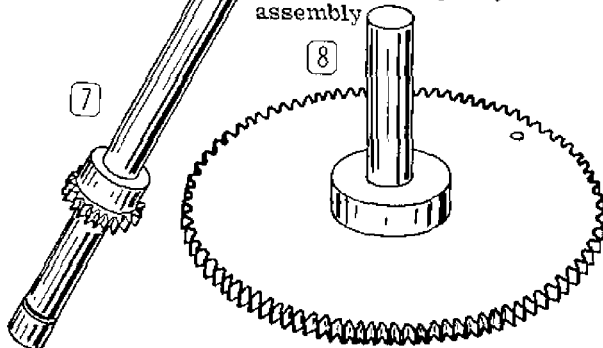

PART No.	PARTS Per Kit	DESCRIPTION
----------	---------------	-------------

Gears-Shafts-Bushings (cont'd.)

⑨ 451-12	1	Nylon cluster gear
⑩ 451-15	1	Tuning drive gear
⑪ 451-16	1	Antibacklash gear
453-76	1	Insulating sideband selector shaft
453-112	1	Insulating antenna trimmer shaft
⑫ 453-78	1	Cluster gear pivot shaft
⑬ 455-6	2	1/4" x 1/4" long shaft bushings
⑭ 455-10	4	17/64" x 7/16" bushing

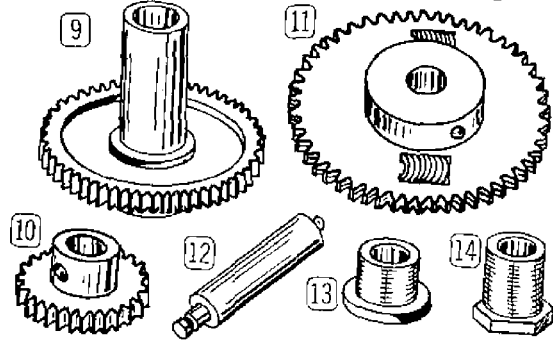

Hardware

⑮ 250-49	39	3-48 x 1/4" screw
⑯ 250-172	2	3-48 x 3/8" screw
⑰ 250-135	1	5-40 hex shoulder screw
⑱ 250-120	1	5-40 x 7/8" stud screw
⑲ 250-124	1	6-32 x 3/16" fillister head screw
⑳ 250-56	64	6-32 x 1/4" screw
㉑ 250-89	16	6-32 x 3/8" screw
㉒ 250-9	2	6-32 x 3/8" round head screw
㉓ 250-13	2	6-32 x 1" screw
㉔ 250-8	4	#6 sheet metal screw
㉕ 250-33	4	6-32 x 1/8" setscrew
㉖ 250-28	1	6-32 x 1/4" setscrew
㉗ 250-137	4	8-32 x 3/8" screw
㉘ 250-105	4	8-32 x 1/8" setscrew
㉙ 250-93	9	8-32 x 1/4" setscrew
㉚ 251-1	9	Spade bolt

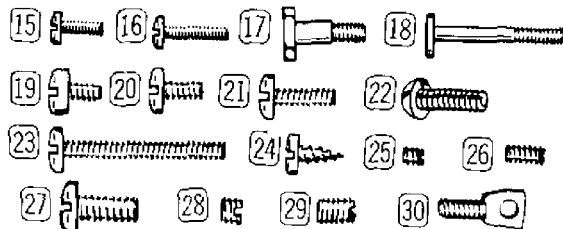

PART No.	PARTS Per Kit	DESCRIPTION
Hardware (cont'd.)		
① 252-1	38	3-48 nut
② 252-40	3	5-40 nut
③ 252-3	86	6-32 nut
④ 252-7	15	Control nut
⑤ 253-1	4	Fiber washer
⑥ 253-21	4	#6 flat washer
⑦ 253-10	11	Control flat washer
⑧ 253-36	2	Brass spring washer
⑨ 253-2	2	#6 fiber shoulder washer
⑩ 253-40	4	#6 flat washer (blue steel)
⑪ 253-49	1	Nylon washer
⑫ 253-11	1	E washer

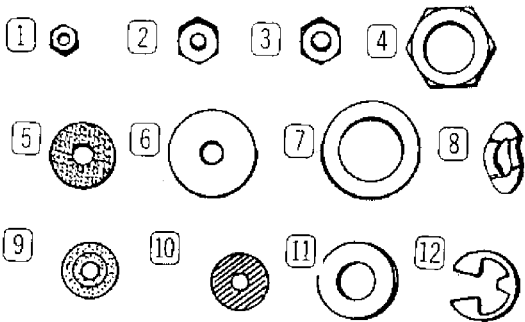

⑬ 253-64	1	Plug washer
⑭ 254-7	62	#3 lockwasher
⑮ 254-1	82	#6 lockwasher
⑯ 254-14	1	1/4" lockwasher
⑰ 254-4	6	Control lockwasher
⑱ 254-5	7	Thin control lockwasher
⑲ 255-13	1	1/4" spacer
⑳ 255-16	2	Dial plate spacer
㉑ 259-6	5	Small #6 solder lug
㉒ 259-1	11	Large #6 solder lug
㉓ 259-10	4	Control solder lug

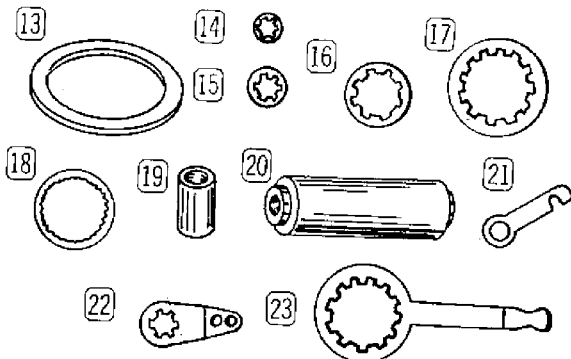

PART No.	PARTS Per Kit	DESCRIPTION
Miscellaneous		
73-4	9	Grommet
㉔ 75-44	2	Mica insulator
206-86	3	Pilot lamp shroud
207-4	3	Cable clamp
208-2	1	Capacitor mounting clip
㉕ 258-1	2	Dial cord spring
㉖ 258-25	1	Cluster gear tension spring
㉗ 260-7	2	IF clip
㉘ 260-29	2	Crystal clip
261-9	2	Small rubber feet
261-21	2	Large rubber feet
407-86	1	"S" meter
421-4	1	8 ampere fuse
423-1	1	Fuse holder
㉙ 435-1	1	Plug ring
㉚ 455-11	1	Shaft adapter
㉛ 456-7	2	Shaft coupling
463-20	1	Dial pointer
464-24	1	Dial drum
㉜ 466-7	1	Dial pulley
490-1	1	Alignment tool
490-6	1	Allen wrench
595-503	1	Manual

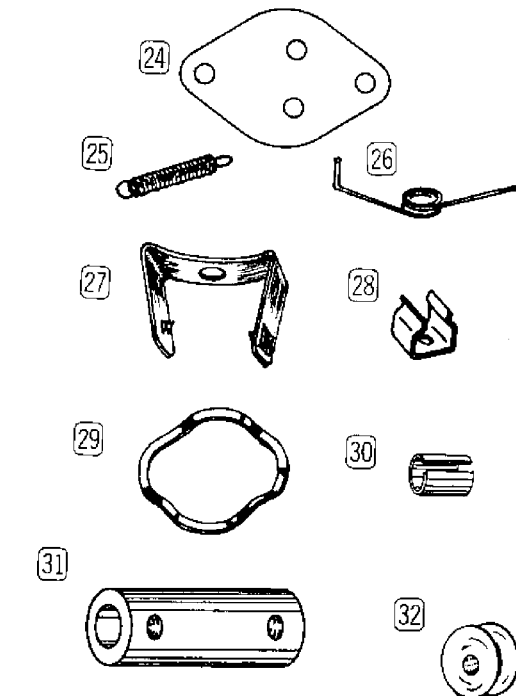



PART PARTS DESCRIPTION
No. Per Kit

NOTE: Refer to the exploded drawing on Page 11 for proper identification of chassis parts.

Metal Parts

100-M363	1	Front panel
204-M223	1	Front panel mounting bracket
100-M213	1	Front dial plate assembly
204-M215	1	Dial pointer bracket
100-M132	2	Dial drum support bracket assembly
100-M212	1	Main dial plate assembly
204-M213	1	Top plate bracket
204-M499	1	Meter mounting bracket
205-M330F605	1	Chassis top plate
100-M348F606	1	Chassis base assembly
206-M184	1	Product detector partition shield
200-M324	1	Chassis base center section
206-M186	1	Oscillator shield
206-M185	1	RF partition shield
90-100	1	Cabinet
100-M19	1	Dial drum drive pulley assembly
100-M125	1	Dial drum plug button assembly
100-M165	1	Pointer drive pulley assembly
100-M200	1	Dial drum shaft assembly
205-M87	1	7-pin tube base shield
204-135	1	Angle bracket
206-3	3	9-pin tube shield, 1-7/8"
206-25	3	7-pin tube shield, 1-3/4"
206-44	1	7-pin tube shield, 2-1/4"
206-54	1	9-pin tube shield, 2-3/8"
485-M7	1	Dial drum plug button

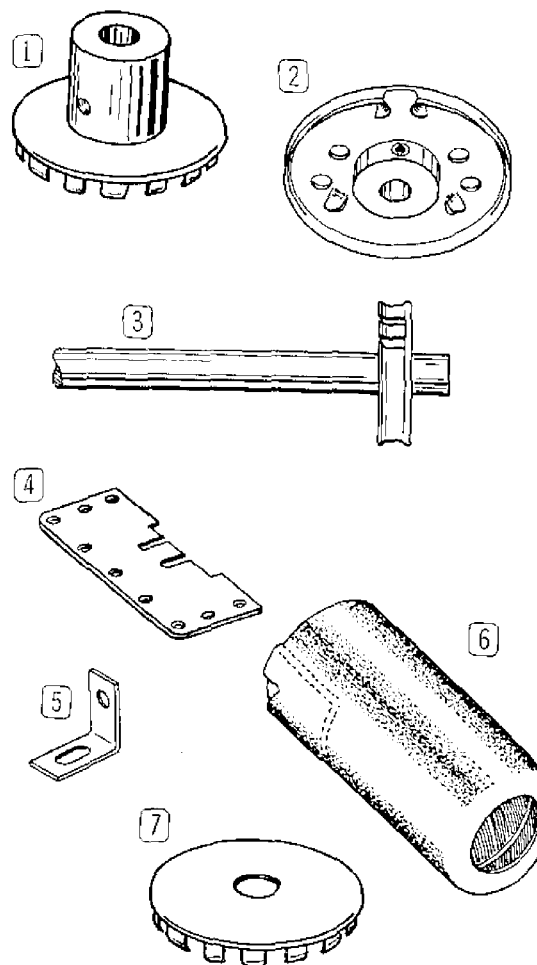

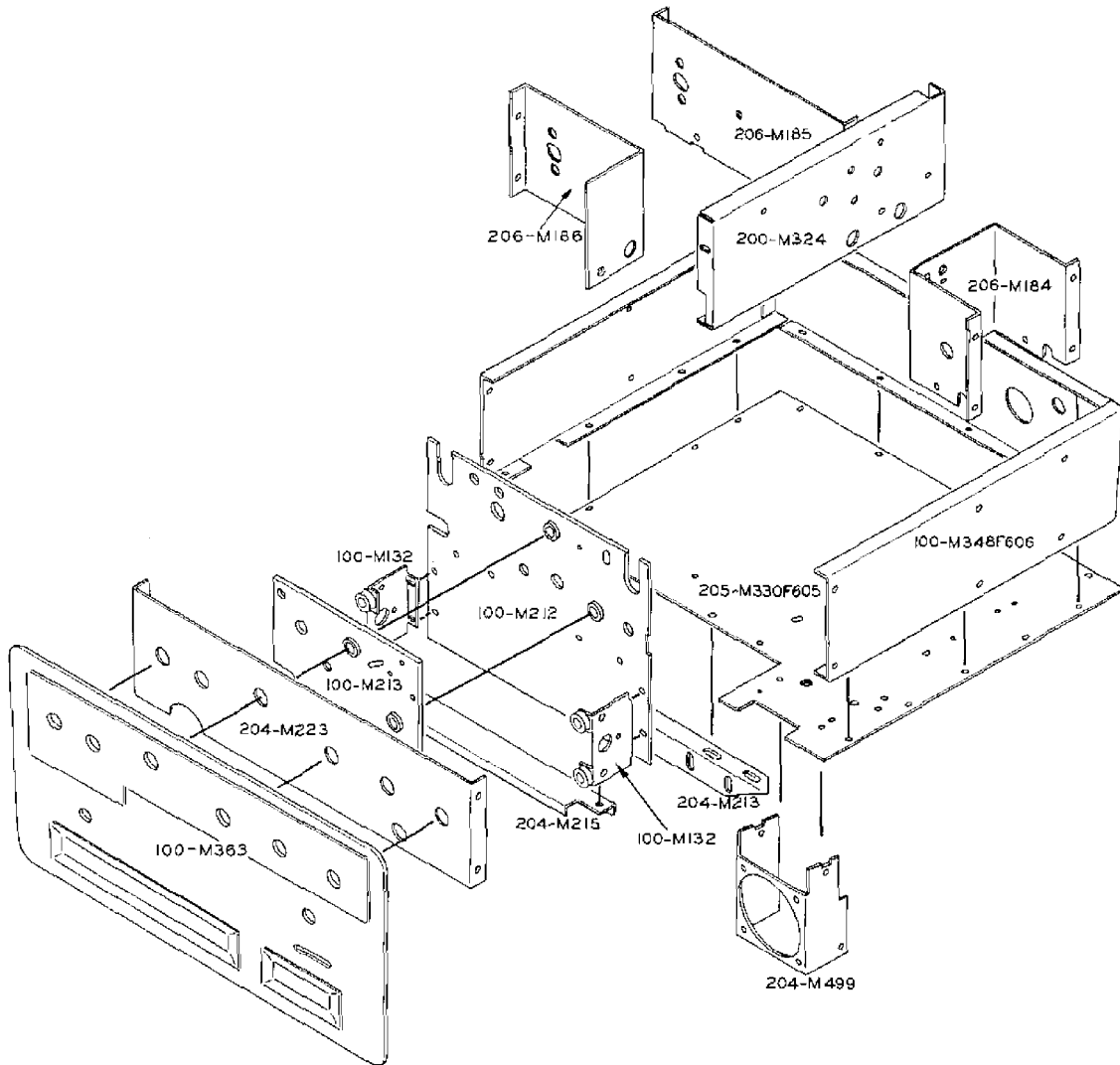

PROPER SOLDERING TECHNIQUES

Only a small percentage of customers find it necessary to return equipment for factory service. By far the largest portion of malfunctions in this equipment are due to poor or improper soldering.

If terminals are bright and clean and free of wax, frayed insulation and other foreign substances, no difficulty will be experienced in soldering. Correctly soldered connections are essential if the performance engineered into a kit is to be fully realized. If you are a beginner with no experience in soldering, a half hour's practice with some odd lengths of wire may be a worthwhile investment.

For most wiring, a 30 to 100 watt iron or its equivalent in a soldering gun is very satisfactory. A lower wattage iron than this may not heat the connection enough to flow the solder smoothly. Keep the iron tip clean by wiping it from time to time with a cloth.

CHASSIS WIRING AND SOLDERING

1. Unless otherwise indicated, all wire used is the type with colored insulation (hookup wire). In preparing a length of hookup wire, 1/4" of insulation should be removed from each end unless directed otherwise in the assembly step.
2. To avoid breaking internal connections when stripping insulation from the leads of transformers or similar components, care should be taken not to pull directly on the lead. In-

stead, hold the lead with pliers while it is being stripped.

3. Leads on resistors, capacitors, and similar components are generally much longer than need be to make the required connections. In these cases, the leads should be cut to proper length before the part is installed. In general, the leads should be just long enough to reach their terminating points.
4. Wherever there is a possibility of bare leads shorting to other parts or to the chassis, the leads should be covered with insulating sleeving. Where the use of sleeving is specifically intended, the phrase "use sleeving" is included in the associated assembly step. In any case where there is the possibility of an unintentional short circuit, sleeving should be used. Extra sleeving is provided for this purpose.
5. Crimp the wire around the terminal only enough to hold it in place solder soldering.
6. Position the work, if possible, so that gravity will help to keep the solder where you want it.
7. Place a flat side of the soldering iron tip against the joint to be soldered until it is heated sufficiently to melt the solder.
8. Then place the solder and it will immediately flow over the joint; use only enough solder to thoroughly wet the junction. It is usually not

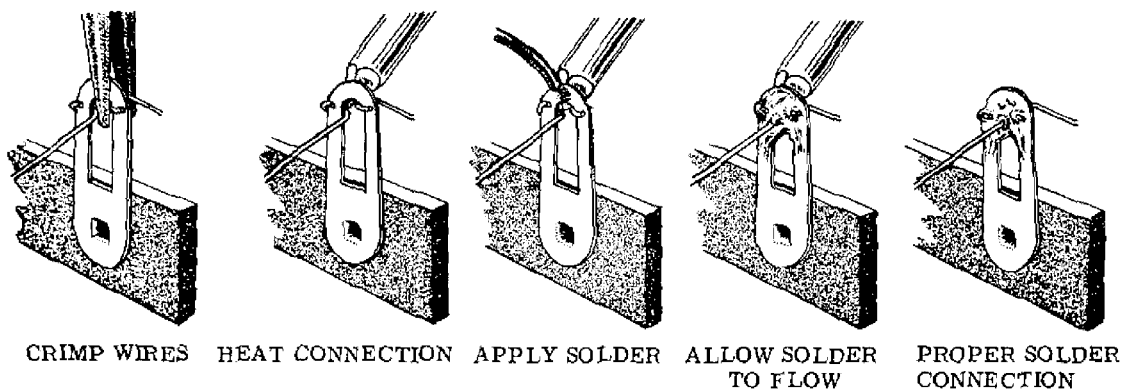

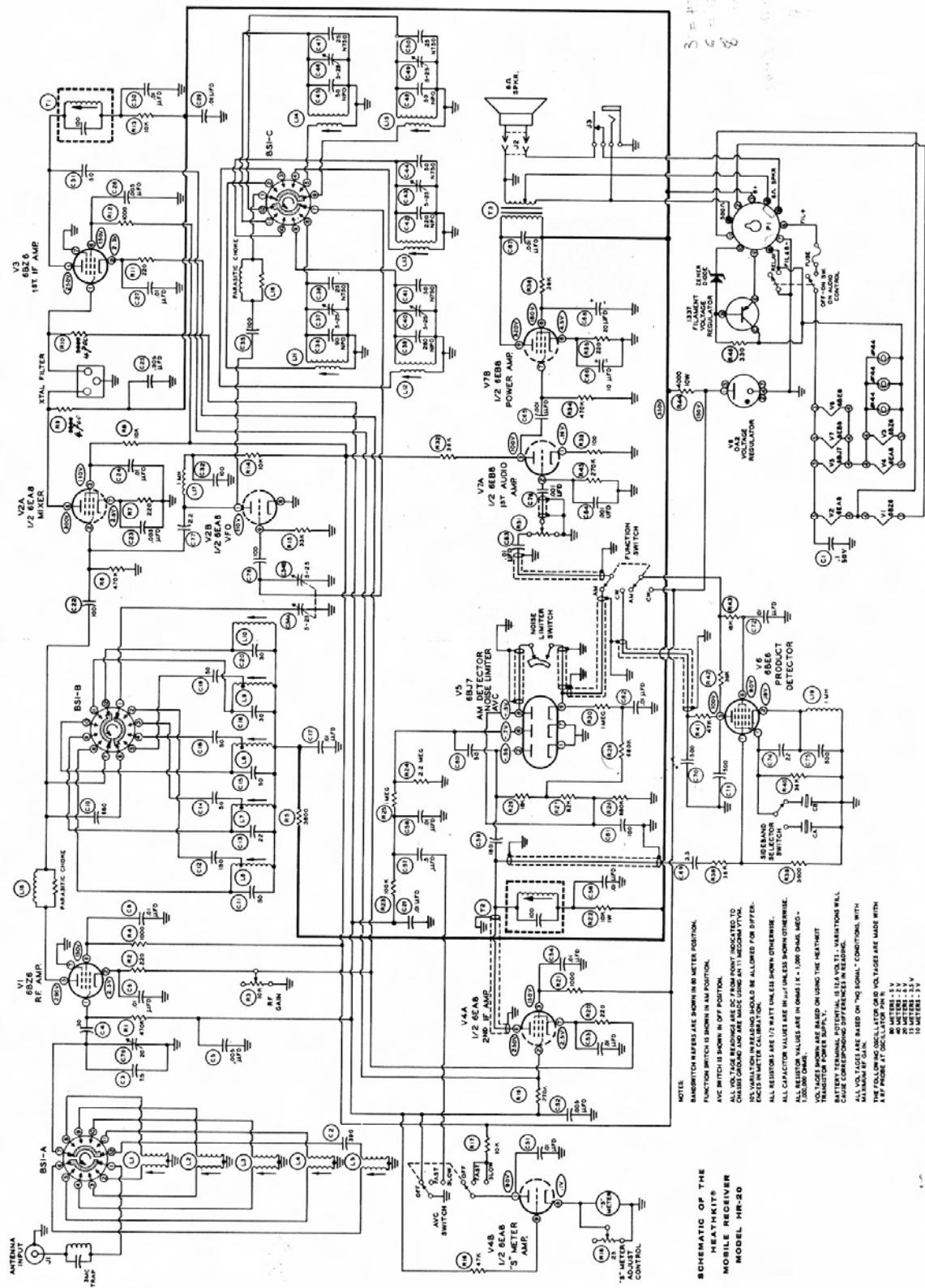

SCHEMATIC OF THE HEATHKIT MOBILE RECEIVER MODEL HR-20

NOTE:
 BANDSWITCH REFERS TO BANDSWITCH IN METER POSITION.
 FUNCTION SWITCH IS SHOWN IN OFF POSITION.
 AVC SWITCH IS SHOWN IN OFF POSITION.
 ALL VOLTAGE READINGS ARE FROM POINT INDICATED TO
 ALL VOLTAGE READINGS ARE IN OHMS UNLESS SHOWN OTHERWISE.
 100% VARIATION IN RESISTOR VALUES IS ALLOWED FOR OFFSET.
 VALUES IN METRIC CALIBRATION.
 ALL CAPACITOR VALUES ARE IN μF UNLESS SHOWN OTHERWISE.
 ALL RESISTOR VALUES ARE IN OHMS UNLESS SHOWN OTHERWISE.
 VOLTAGE VALUES ARE IN OHMS $\times 1,000$ UNLESS SHOWN OTHERWISE.
 TRANSMITTER POWER SUPPLY.
 BATTERY TERMINAL POTENTIAL IS 13.6 VOLTS ± 0.1 VOLTAGE WILL
 CAUSE OPERATING DIFFERENCES IN GAIN.
 ALL VOLTAGE READINGS ARE BASED ON "NO SIGNAL" CONDITIONS WITH
 A 400 OHM LOAD.
 THE FOLLOWING OSCILLATOR AND VOLTAGE ARE MADE WITH
 A 400 OHM LOAD:
 10 METERS - 1.1 V
 20 METERS - 1.1 V
 30 METERS - 1.1 V
 40 METERS - 1.1 V
 50 METERS - 1.1 V
 60 METERS - 1.1 V
 70 METERS - 1.1 V
 80 METERS - 1.1 V
 90 METERS - 1.1 V
 100 METERS - 1.1 V

WIRING SHOWN IS FOR NEGATIVE GROUND VEHICLES.

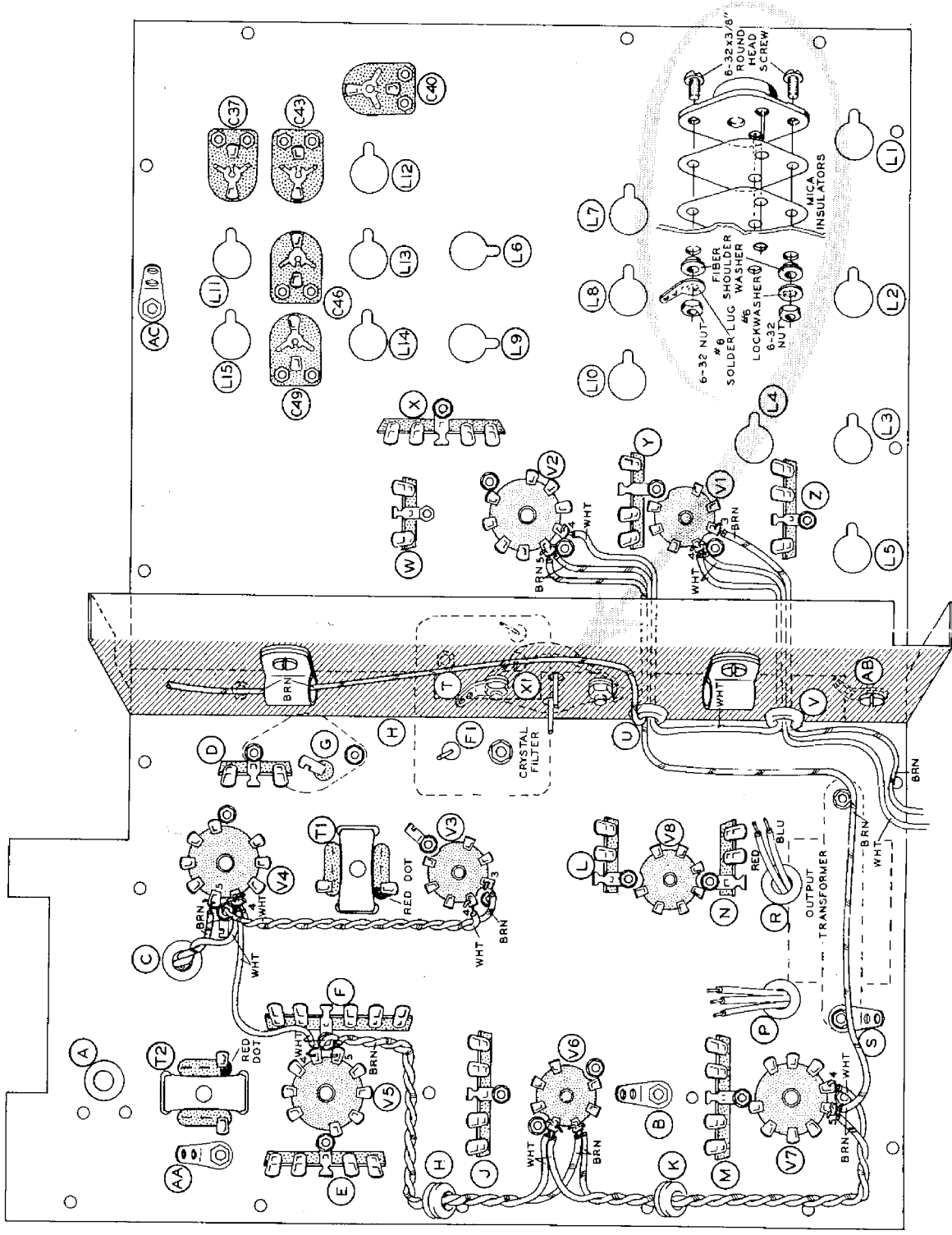

Pictorial 1

necessary to fill the entire hole in the terminal with solder.

9. Remove the solder and then the iron from the completed joint. Use care not to move the leads until the solder is solidified.

A poor or cold solder joint will usually look crystalline and have a grainy texture, or the solder will stand up in a blob and will not have adhered to the joint. Such joints should be reheated until the solder flows smoothly. In some cases, it may be necessary to add a little more solder to achieve a smooth, bright appearance.

NOTE: ALL GUARANTEES ARE VOIDED AND WE WILL NOT REPAIR OR SERVICE INSTRUMENTS IN WHICH ACID CORE SOLDER OR PASTE FLUXES HAVE BEEN USED. WHEN IN DOUBT ABOUT SOLDER, IT IS RECOMMENDED THAT A NEW ROLL PLAINLY MARKED "ROsin CORE RADIO SOLDER" BE PURCHASED.

STEP-BY-STEP PROCEDURE

The following instructions are presented in a logical step-by-step sequence to enable you to complete your kit with the least possible confusion. Be sure to read each step all the way through before beginning the specified operation. Also read several steps ahead of the actual step being performed. This will familiarize you with the relationship of the subsequent operations. When the step is completed, check it off in the space provided. This is particularly important as it may prevent errors or omissions, especially if your work is interrupted. Some kit builders have also found it helpful to mark each wire and part in colored pencil on the Pictorial as it is added.

The fold-out diagrams in this manual may be removed and attached to the wall above your working area; but because they are an integral part of the instructions, they should be returned to the manual after the kit is completed.

In general, the illustrations in this manual correspond to the actual configuration of the kit; however, in some instances the illustra-

tions may be slightly distorted to facilitate clearly showing all of the parts.

The abbreviation "NS" indicates that a connection should not be soldered yet as other wires will be added. When the last wire is installed, the terminal should be soldered and the abbreviation "S" is used to indicate this. Note that a number will appear after each solder instruction. This number indicates the number of leads that are supposed to be connected to the terminal in point before it is soldered. For example, if the instruction reads, "Connect a wire to lug 1 (S-2)," it will be understood that there will be two wires connected to the terminal at the time it is soldered. (In cases where a wire passes through a terminal or lug and then connects to another point, it will count as two wires, one entering and one leaving the terminal.)

The steps directing the installation of resistors include color codes to help identify the parts. Also, if a part is identified by a letter-number designation (R1, C1, etc.) on the Schematic, its designation will appear at the beginning of the assembly step which directs its installation.

STEP-BY-STEP ASSEMBLY

All terminal strips and small #6 solder lugs will require that a lockwasher be placed under and over their mounting feet when they are mounted. This will prevent them from changing position during mounting; it will also provide a positive ground connection.

The phrase "#6 hardware" means 6-32 x 1/4" screws, #6 lockwashers, and 6-32 nuts. The phrase "#3 hardware" means 3-48 x 1/4" screws, #3 lockwashers, and 3-48 nuts.

CHASSIS TOP PLATE PARTS MOUNTING

Refer to Pictorial 1 for the following steps.

- () Install rubber grommets at A, C, P, and R.
- () Prepare six 11-lug terminal strips as shown in Detail 1A. Cut each 11-lug terminal into the sections shown and discard the crossed out portions. Each terminal strip is numbered from left to right, with the mounting foot toward you. This numbering system will be used throughout the assembly of this kit.
- () Install a 9-pin tube socket and a small #6 solder lug at V4, as shown, using #3 hardware. Bend up the solder lug vertically as shown. Use a lockwasher on the bottom and top of the solder lug. Be sure to place the blank space as shown.

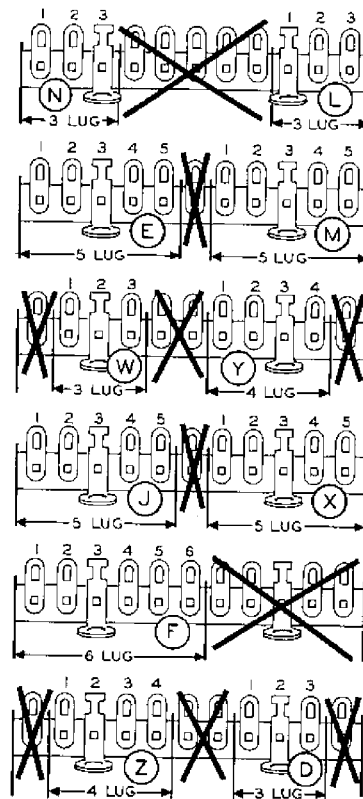
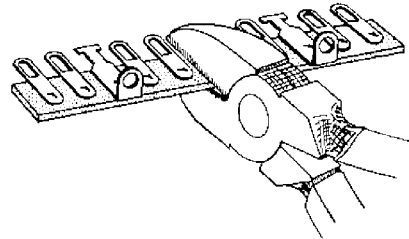

Detail 1A

NOTE: Carefully observe Pictorial 1 for the type and position of each terminal strip used in the following steps.

- () Install a 9-pin tube socket at V5 with 5-lug and 6-lug terminal strips at E and F, respectively, as shown in Detail 1B. Use #3 hardware.

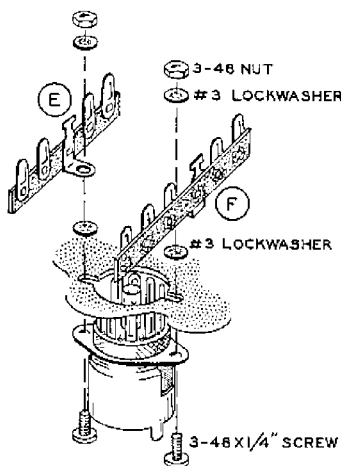

Detail 1B

- () Install a 9-pin tube socket at V7 with a 5-lug terminal strip at M as shown. Use #3 hardware.
- () Install the remaining 9-pin tube socket as shown at V2. Use #3 hardware.
- () Install a 7-pin tube socket with a small #6 solder lug at V3. Use #3 hardware. Bend up the solder lug vertically as shown.
- () Install a 7-pin tube socket at V6, using #3 hardware.
- () Install a 7-pin tube socket at V8 with 3-lug terminal strips at L and N as shown. Use #3 hardware.
- () Install the remaining 7-pin tube socket at V1 and a 4-lug terminal strip at Y as shown. Use #3 hardware.

- () R18. Cut off lug 1 of the 25 Ω control (#11-30) as short as possible, as shown in Detail 1D. Install the control with its remaining lug centered in hole G and mount a 3-lug terminal strip at D. See Pictorial 1 and Detail 1D.

Install the designated terminal strips at the following locations. See Pictorial 1 for the lug type and exact position of each strip. Use #3 hardware as shown in Detail 1C.

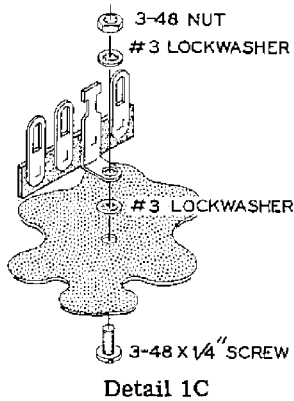

<u>TERMINAL STRIP</u>	<u>LOCATION</u>
() 5-lug	J
() 3-lug	W
() 5-lug	X
() 4-lug	Z

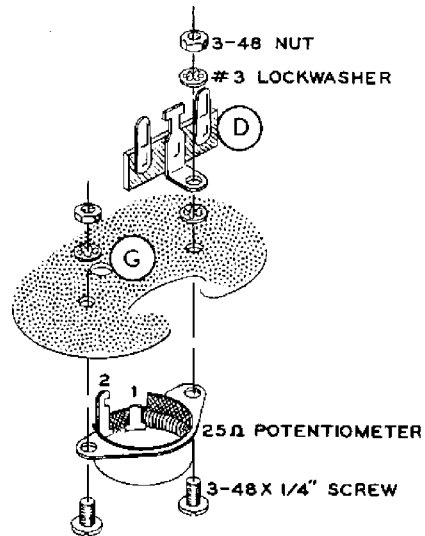

- () Mount the IF coils at T1 and T2 with the red dot positioned as shown. Use the IF mounting clips. See Detail 1E. Press the clips down on the chassis until they lock into place.

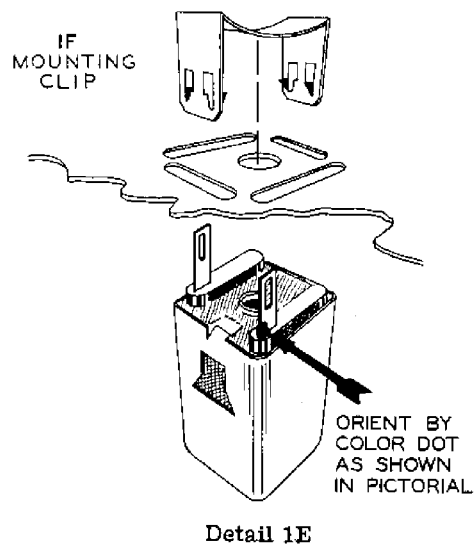

- () Insert the red and blue leads of the audio output transformer (#51-84) in grommet R and insert the remaining three leads in grommet P. Secure the transformer to the chassis top plate. Use #6 hardware as shown in Detail 1F (with solder lug at S).

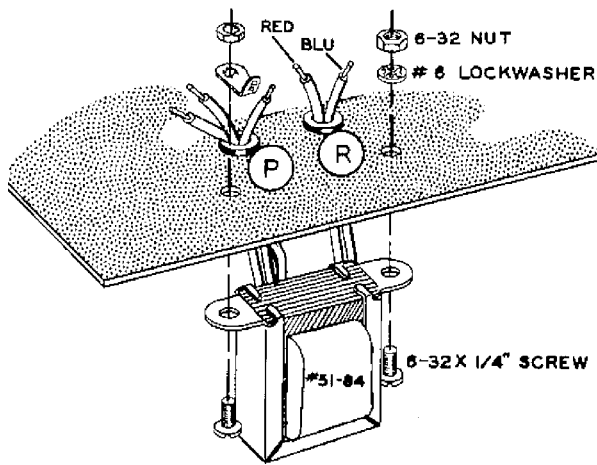

Detail 1F

Install the 5-25 $\mu\mu\text{f}$ trimmer capacitors at the following locations. See Pictorial 1. Use #3 hardware as shown in Detail 1G. Make certain the capacitors are centered in the holes and that the trimmers turn freely.

- () C37
- () C40
- () C43
- () C46
- () C49

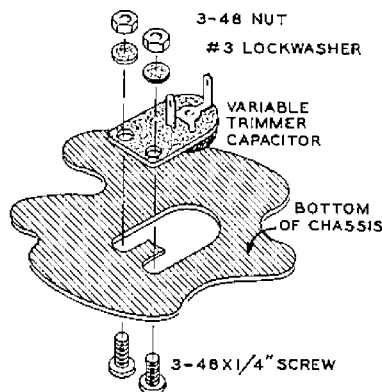

Detail 1G

- () Install and position large #6 solder lugs at AA, and AC as shown. Use #6 hardware.
- () Install and position a large #6 solder lug at B. Use #3 hardware.
- () Mount the crystal filter (#404-12) on the chassis top plate at the location shown in Pictorial 1. Use a #6 lockwasher and 6-32 nut on each mounting bolt.
- () Install rubber grommets at U and V of the chassis base center section (#200-M324).
- () Mount the transistor at location X1 with two mica insulators, a #6 solder lug at T on one mounting screw. Use 6-32 x 3/8" round head screws, #6 fiber shoulder washers, a #6 lockwasher, and 6-32 nuts.
- () Install two cable clamps to the chassis base center section. Use 6-32 x 3/8" screws, #6 lockwashers, and 6-32 nuts.
- () Install and position a large #6 solder lug at AB on the chassis base center section. Use #6 hardware.
- () Mount the chassis base center section to the chassis top plate. Use #6 hardware, but leave it loose for positioning later.

INITIAL FILAMENT WIRING

Refer to Pictorial 1 for the following steps.

- () Prepare the filament wires by twisting an 18" length of brown and an 18" length of white hookup wire together until about 2 turns per inch result. Cut the twisted hookup wire to the lengths given in the following steps and connect as indicated. The brown and white wires will be designated B and W before each lug number. Make careful note of this in each step. Route the filament wires as shown in Pictorial 1.

<u>LENGTH</u>	<u>FROM LUG</u>	<u>TO LUG</u>
() 4"	Place 5/16" rubber grommet K over these wires, then connect B5 (NS) and W4 (S-1) of V7	B3 (NS) and W4 (NS) of V6.
() 4-3/4"	Insert these wires through grommet H, then connect B3 (S-2) and W4 (S-2) of V6	B5 (S-1) and W4 (NS) of V5.
() 3-1/4"	B5 (NS) and W4 (NS) of V 4	B3 (S-1) and W4 (S-1) of V3.
() 5-1/2"	B5 (NS) and W4 (NS) of V4	through grommet C and leave free.

In the following steps, use single lengths of brown or white hookup wire as called for.

<u>COLOR-LENGTH</u>	<u>FROM LUG</u>	<u>TO LUG</u>
() White 2-1/4"	4 of V4 (S-3)	4 of V5 (S-2).
() Brown 8-1/2"	5 of V7 (S-2)	through grommet U to lug 5 of V2 (NS).
() Brown 12"	5 of V2 (NS)	through grommet U and through the cable clamp as shown. Leave the end free.
() White 6-1/2"	4 of V2 (S-1)	through grommet U, through grommet V to lug 4 of V1 (NS).
() White 6-1/2"	4 of V1 (S-2)	through grommet V and leave free.
() Brown 6-1/4"	3 of V1 (S-1)	through grommet V and leave free.



POINT-TO-POINT WIRING

Refer to Pictorial 2 (fold-out from Page 21) for the following steps.

Connect the following colored and #20 (small bare) wire as indicated. The correct length is given at the beginning of each step. Route each wire as shown in Pictorial 2.

<u>COLOR-LENGTH</u>	<u>FROM LUG</u>	<u>TO LUG</u>
() Black 7"	1 of terminal strip E (NS)	leave free.
() Black 4-1/4"	8 of V4 (S-2).	insert through grommet C and leave free.
() Black 2-1/4"	8 of V4 (NS)	lug at hole G (S-1).
() Black 8"	2 of terminal strip L (NS)	leave free.
() Black 5-1/2"	2 of terminal strip L (NS)	through grommet V to lug 1 of terminal strip Z (NS).
() Orange 8"	4 of terminal strip J (NS)	through 3/16" grommet H, grommet A and leave free.
() Orange 2-3/4"	1 of terminal strip F (NS)	insert through grommet C and leave free.
() Orange 5"	1 of terminal strip F (NS)	5 of V8 (NS).
() Orange 2-1/2"	5 of V8 (NS)	4 of terminal strip M (NS).
() Orange 6-1/4"	1 of V4 (NS)	leave free.
() Orange 1-1/4"	1 of V8 (S-1)	3 of terminal strip L (NS).
() Orange 3-3/4"	3 of terminal strip L (NS)	through grommet U to lug 1 of terminal strip Y (NS).
() Orange 3"	1 of terminal strip X (NS)	1 of terminal strip Y (NS).
() Yellow 5"	6 of terminal strip F (NS)	leave free.
() Yellow 3-3/4"	6 of terminal strip F (NS)	1 of terminal strip D (NS).
() Yellow 8-1/4"	1 of terminal strip D (NS)	through grommet V to lug 3 of terminal strip Z (NS).
() Brown 2"	5 of V4 (S-3)	leave free.
() Red 6-1/2"	2 of terminal strip F (NS)	through lug 2 (NS) to lug 1 (NS) of terminal strip N.
() Red 4"	2 of terminal strip N (NS)	1 of terminal strip M (NS).
() Red 4-1/2"	2 of terminal strip N (S-4)	through grommet U to lug 2 of terminal strip Y (NS).
() Blue 1-1/2"	8 of V5 (NS)	4 of terminal strip E (NS).
() Blue 1-1/4"	4 of terminal strip F (NS)	6 of V5 (NS).
() Blue 1"	5 of V3 (S-1)	1 of T1 (NS).
() Green 2-1/4"	1 of V6 (NS)	leave free.
() #20 bare wire 1-1/2"	3 of terminal strip E (NS)	through lug 1 (S-2), through the center post (S-2) to lug 7 (S-1) of V5.
() #20 bare wire 3/4"	7 of V3 (NS)	solder lug of V3 (NS).
() #20 bare wire 1-1/4"	1 of V3 (NS)	F1 (S-1).
() #20 bare wire 1-1/4"	3 of terminal strip N (NS)	through lug 4 (S-2), through the center post (NS), to lug 7 (S-1) of V8.

COLOR-LENGTH	FROM LUG	TO LUG
() #20 bare wire	2 of V8 (S-1)	center post of V8 (S-3).
() #20 bare wire	6 of V2 (NS)	F2 (S-1).
() #20 bare wire	2 of terminal strip W (NS)	through lug 8 (S-2) to center post (NS) of V2.
() #20 bare wire	7 of V1 (S-1)	to the hole in lug 3 of terminal strip Y (S-1).
() Brown 5"	1 of transistor X1 (S-1)	Place through clamp on center shield and leave the end free.

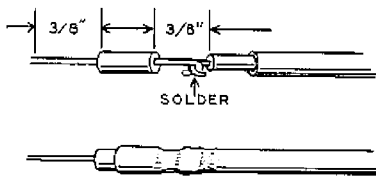

Detail 2A

- () Referring to Detail 2A, cut both leads of the zener diode to 3/8" and connect one end of a 4-1/2" white wire to the violet band lead of the zener diode. Use sleeving to cover this connection.
- () Connect the free lead of the zener diode to lug 2 of transistor X1 (NS). Place the white wire through the clamp on the center shield and leave the end free.

NOTE: All resistors are 1/2 watt unless specified otherwise in the steps.

- () R46. Connect a 330 Ω (orange-orange-brown) resistor from lug 2 of transistor X1 (S-2) to solder lug T (NS).
- () Connect one end of a 3" green wire to solder lug T (S-2). Pass the other end of this wire through the cable clamp as shown, and leave free.

NOTE: Some of the following steps will require shielded wire of specified lengths. Prepare each end of these shielded wires as shown in Detail 2B. Route the wires as shown in Pictorial 2.

CAUTION: The insulation on the center conductor melts very easily; use care when soldering to prevent shorts in the shielded wire.

- () At one end of a 4" shielded wire, connect the inner conductor to lug 9 of V5 (NS). Connect the shield at this same end to the #20 bare wire between lug 1 of V5 and ter-

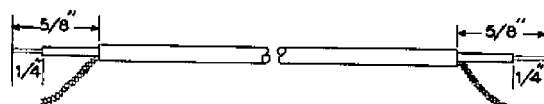
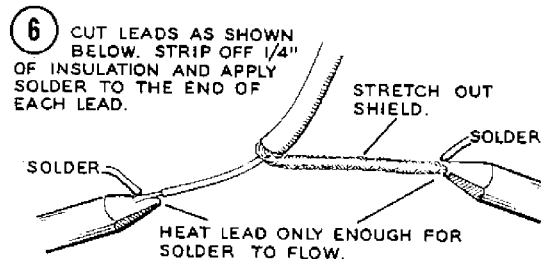
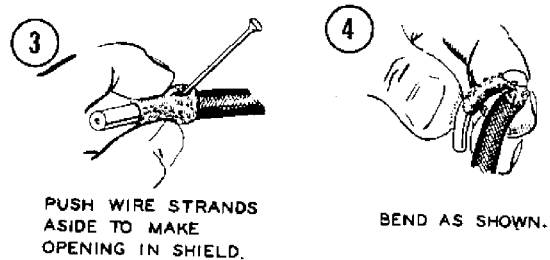
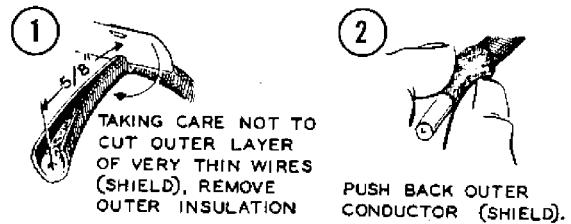

Detail 2B



- minal strip E (NS). Wrap the shield on the #20 bare wire just enough to hold it there, then cut off the excess shield. Insert the other end of the shielded wire through grommet A and leave it free.
- () At one end of a 2-1/2" shielded wire, connect the inner conductor to lug 2 of T2 (NS), and connect the shield to solder lug AA (NS). Connect the inner conductor on the other end to lug 6 of V4 (S-1) and connect the shield to the solder lug of V4 (NS).
 - () Place one end of a 5" shielded wire through grommet H. At the same end, connect the inner conductor to lug 5 (NS) and the shield to the lower hole in lug 3 (S-1) of terminal strip J. At the other end of this shielded wire, connect the inner conductor to lug 2 of T2 (NS) and connect the shield to solder lug AA (S-2).
 - () Place one end of a 7" shielded wire through grommet H. At one end connect the inner conductor to lug 2 (NS) and connect the shield to lug 1 (NS) of terminal strip J. Insert the other end through grommet A and leave it free.
 - () At one end of a 3-3/4" shielded wire, connect the inner conductor to lug 3 (NS) and connect the shield to lug 2 (NS) of terminal strip D. Insert the other end through grommet C and leave it free.
- () Connect the red lead coming from grommet R to lug 1 of terminal strip N (NS).
 - () Connect the blue lead coming from grommet R to lug 2 of terminal strip M (NS).
 - () Connect the black lead coming from grommet P to lug 3 of terminal strip N (NS).
 - () Cut the green lead to 3-1/4" and the white lead to 2-1/2" (measured from grommet P). Prepare the end of the white lead as the leads were prepared in the previous steps (strip 1/4"). Strip 3/4" insulation from the end of the green lead and apply a small amount of solder.
 - () Connect one end of a 3-1/4" red hookup wire to lug 1 of terminal strip N (NS). Strip off about 3/4" of insulation from the other end and leave it free.
 - () Connect one end of a 3-1/2" black hookup wire to lug 3 of terminal strip N (NS). Strip off about 3/4" of insulation from the other end and leave it free.
 - () At one end of a 9-1/4" shielded wire, connect the inner conductor to lug 5 of terminal strip M (NS) and the shield to lug 3 of terminal strip M (NS). Place the other end through the two cable clamps on the base center section as shown in Pictorial 2, and leave free.

NOTE: Refer to Pictorial 2 when cutting and positioning the leads of the audio output transformer. Then strip 1/4" of insulation from the end of each lead and apply a small amount of solder to it before making each of the following connections, if not already tinned.

RESISTORS-DETECTORS, IF AND AUDIO STAGES

Refer to Pictorial 3 (fold-out from Page 23) for the following steps.

Connect and position the following 1/2 watt resistors, unless otherwise specified, as shown in Pictorial 3. Cut off any excess lead lengths. Make sure there are not any unintentional short circuits when wiring.

<u>VALUE</u>	<u>FROM LUG</u>	<u>TO LUG</u>
() R28. 680 K Ω (blue-gray-yellow)	3 of terminal strip E (NS)	4 of terminal strip E (NS)
() R26. 18 K Ω (brown-gray-orange)	5 of terminal strip E (NS)	2 of V5 (NS).
() R29. 680 K Ω (blue-gray-yellow)	2 of terminal strip E (NS)	5 of terminal strip E (NS).

<u>VALUE</u>	<u>FROM LUG</u>	<u>TO LUG</u>
() R27. 82 K Ω (gray-red-orange)	4 of terminal strip E (NS)	5 of terminal strip E (S-3).
() R30. 1 megohm (brown-black-green)	2 of terminal strip E (NS)	9 of V5 (NS).
() R23. 100 K Ω (brown-black-yellow)	5 of terminal strip F (NS)	6 of terminal strip F (NS).
() R25. 1 megohm (brown-black-green)	4 of terminal strip F (NS)	5 of terminal strip F (NS).
() R24. 2.2 megohm (red-red-green)	3 of terminal strip F (NS)	4 of terminal strip F (S-3).
() R22. 10 K Ω 1 watt (brown-black-orange)	2 of terminal strip F (NS)	1 of T2 (NS).
() R21. 1000 Ω (brown-black-red)	1 of terminal strip F (NS)	3 of V4 (NS).
() R16. 47 K Ω (yellow-violet-orange)	1 of terminal strip D (NS)	9 of V4 (S-1).
() R19. 270 K Ω (red-violet-yellow)	1 of terminal strip D (NS)	2 of V4 (NS).
() R13. 10 K Ω (brown-black-orange)	2 of terminal strip F (NS)	2 of T1 (NS).
() R10. 3600 Ω (orange-blue-red)	1 of terminal strip D (NS)	1 of V3 (S-2).
() R12. 1000 Ω (brown-black-red)	6 of V3 (NS)	5 of V8 (S-3).
() R11. 220 Ω (red-red-brown)	2 of V3 (NS)	2 of terminal strip L (S-3).
() R43. 18 K Ω (brown-gray-orange)	6 of V6 (NS)	4 of terminal strip J (NS).
() R42. 36 K Ω (orange-blue-orange)	5 of V6 (NS)	4 of terminal strip J (S-3).
() R41. 47 K Ω (yellow-violet-orange)	5 of V6 (NS)	2 of terminal strip J (NS).
() R40. 36 K Ω (orange-blue-orange)	1 of V6 (NS)	solder lug B (NS).
() R39. 3600 Ω (orange-blue-red)	7 of V6 (NS)	solder lug B (NS).

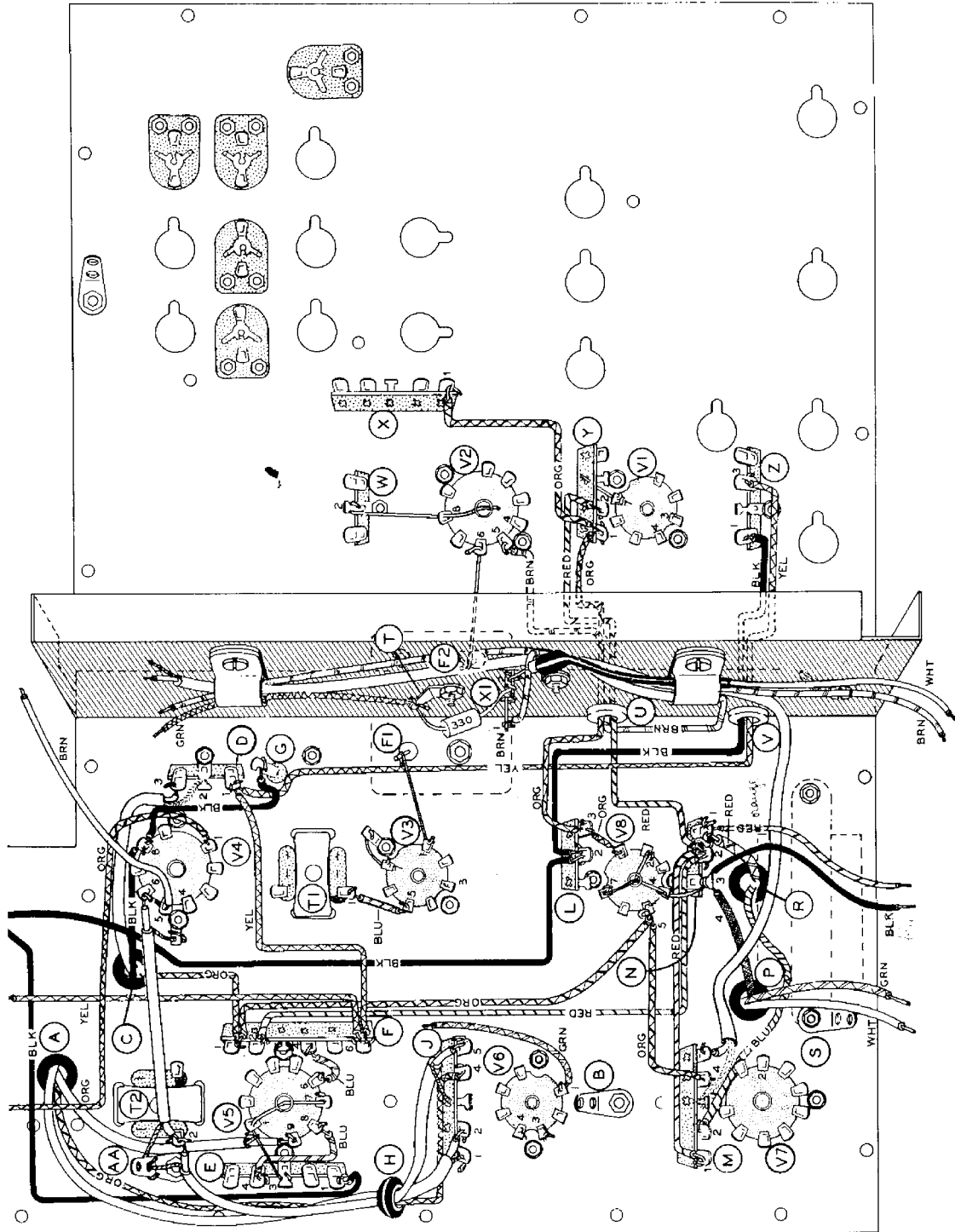

Pictorial 2

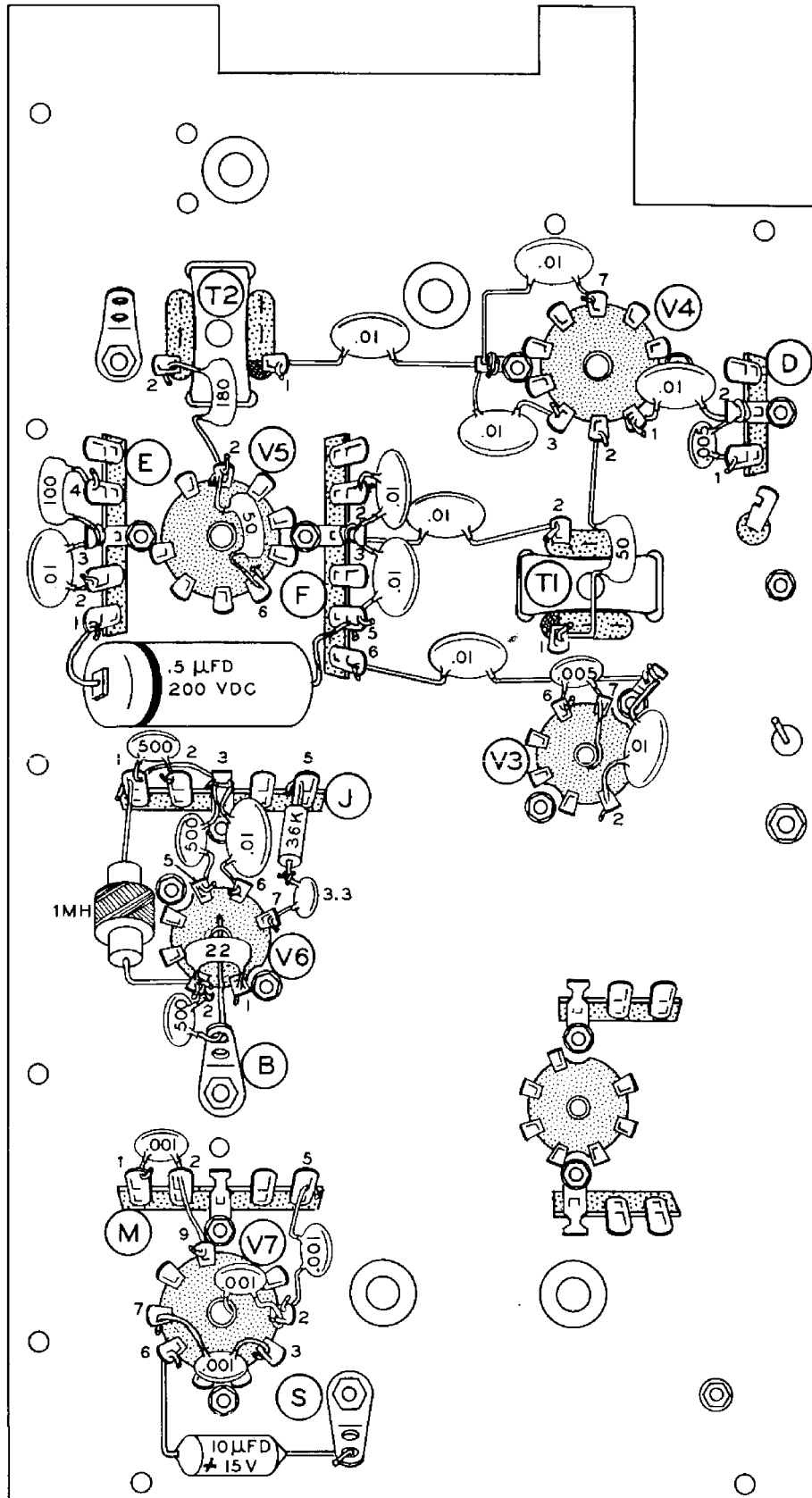

Pictorial 4



<u>VALUE</u>	<u>FROM LUG</u>	<u>TO LUG</u>
() R33. 100 Ω (brown-black-brown)	1 of V7 (S-1)	around 3 of terminal strip M (S-3) to center post of V7 (NS).
() R36. 36 K Ω (orange-blue-orange)	1 of terminal strip M (NS)	8 of V7 (NS).
() R34. 470 K Ω (yellow-violet-yellow)	7 of V7 (NS)	solder lug S (NS).
() R35. 220 Ω (red-red-brown)	6 of V7 (NS)	solder lug S (NS).
() R32. 36 K Ω (orange-blue-orange)	3 of V7 (NS)	4 of terminal strip M (S-2).
() R45. 270 K Ω (red-violet-yellow)	2 of V7 (NS)	solder lug S (NS).
() R44. Connect the 4000 Ω wire-wound 10 watt resistor from lug 3 of terminal strip L (S-3) to lug 1 of terminal strip N (S-4).		

CAPACITORS-DETECTOR, IF AND AUDIO STAGES

Refer to Pictorial 4 for the following steps.

Connect and position each of the following capacitors (mica and disc ceramic) in an upright position, perpendicular to the chassis, as shown in Pictorial 4.

<u>VALUE-TYPE</u>	<u>FROM LUG</u>	<u>TO LUG</u>
() C53. .01 μ fd disc ceramic	7 of V4 (NS)	solder lug of V4 (NS).
() C56. .01 μ fd disc ceramic	solder lug of V4 (NS)	1 of T2 (S-2).
() C54. .01 μ fd disc ceramic	3 of V4 (S-2)	solder lug of V4 (S-4).
() C51. .01 μ fd disc ceramic	1 of V4 (S-2)	2 of terminal strip D (NS).
() C52. .005 μ fd disc ceramic	1 of terminal strip D (S-6)	2 of terminal strip D (S-3).
() C59. 180 μ μ f mica	2 of V5 (NS)	2 of T2 (S-3).
() C60. 50 μ μ f mica	2 of V5 (S-3)	6 of V5 (S-2).
() C61. 100 μ μ f mica	3 of terminal strip E (NS)	4 of terminal strip E (S-4).
() C62. .01 μ fd disc ceramic	3 of terminal strip E (S-4)	2 of terminal strip E (S-3).

<u>VALUE-TYPE</u>	<u>FROM LUG</u>	<u>TO LUG</u>
() C29. .01 μ fd disc ceramic	3 of terminal strip F (NS)	2 of terminal strip F (S-4).
() C58. .01 μ fd disc ceramic	3 of terminal strip F (NS)	5 of terminal strip F (NS)
() C30. .01 μ fd disc ceramic	3 of terminal strip F (S-4)	2 of T1 (S-2).
() C21. .01 μ fd disc ceramic	6 of terminal strip F (S-4)	solder lug of V3 (NS).
() C31. 50 μ μ f mica	2 of V4 (S-2)	1 of T1 (S-2).
() C28. .005 μ fd disc ceramic	6 of V3 (S-2)	through 7 (S-3) to center post (S-2) of V3.
() C27. .01 μ fd disc ceramic	2 of V3 (S-2)	solder lug of V3 (S-3).
() C72. .01 μ fd disc ceramic	6 of V6 (S-2)	around 3 (NS) to 1 (NS) of terminal strip J .
() C71. 500 μ μ f disc ceramic	5 of V6 (S-3)	3 of terminal strip J (S-3).
() C70. 500 μ μ f disc ceramic	1 of terminal strip J (NS)	2 of terminal strip J (S-3).
() C74. 22 μ μ f mica	2 of V6 (NS)	1 of V6 (S-3).
() C75. 500 μ μ f disc ceramic	2 of V6 (NS)	through solder lug B (S-4) to center post of V6 (S-1).
() C67. .001 μ fd disc ceramic	1 of terminal strip M (S-3)	through 2 of terminal strip M (S-3) to 9 of V7 (S-1).
() C76. .001 μ fd disc ceramic	2 of V7 (NS)	5 of terminal strip M (S-2).
() C64. .001 μ fd disc ceramic	2 of V7 (S-3)	center post of V7 (S-2).
() C65. .001 μ fd disc ceramic	3 of V7 (S-2)	7 of V7 (S-2).
() R38 and C69, Connect a 36 K Ω (orange-blue-orange) 1/2 watt resistor in series with a 3.3 μ μ f disc ceramic capacitor as shown in Detail 4A. Connect the lead on one end of this combination to lug 7 of V6 (S-2) and the other lead to lug 5 of terminal strip J (S-2).		

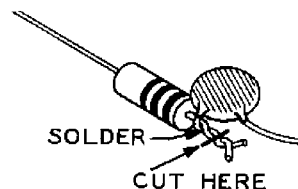

Detail 4A

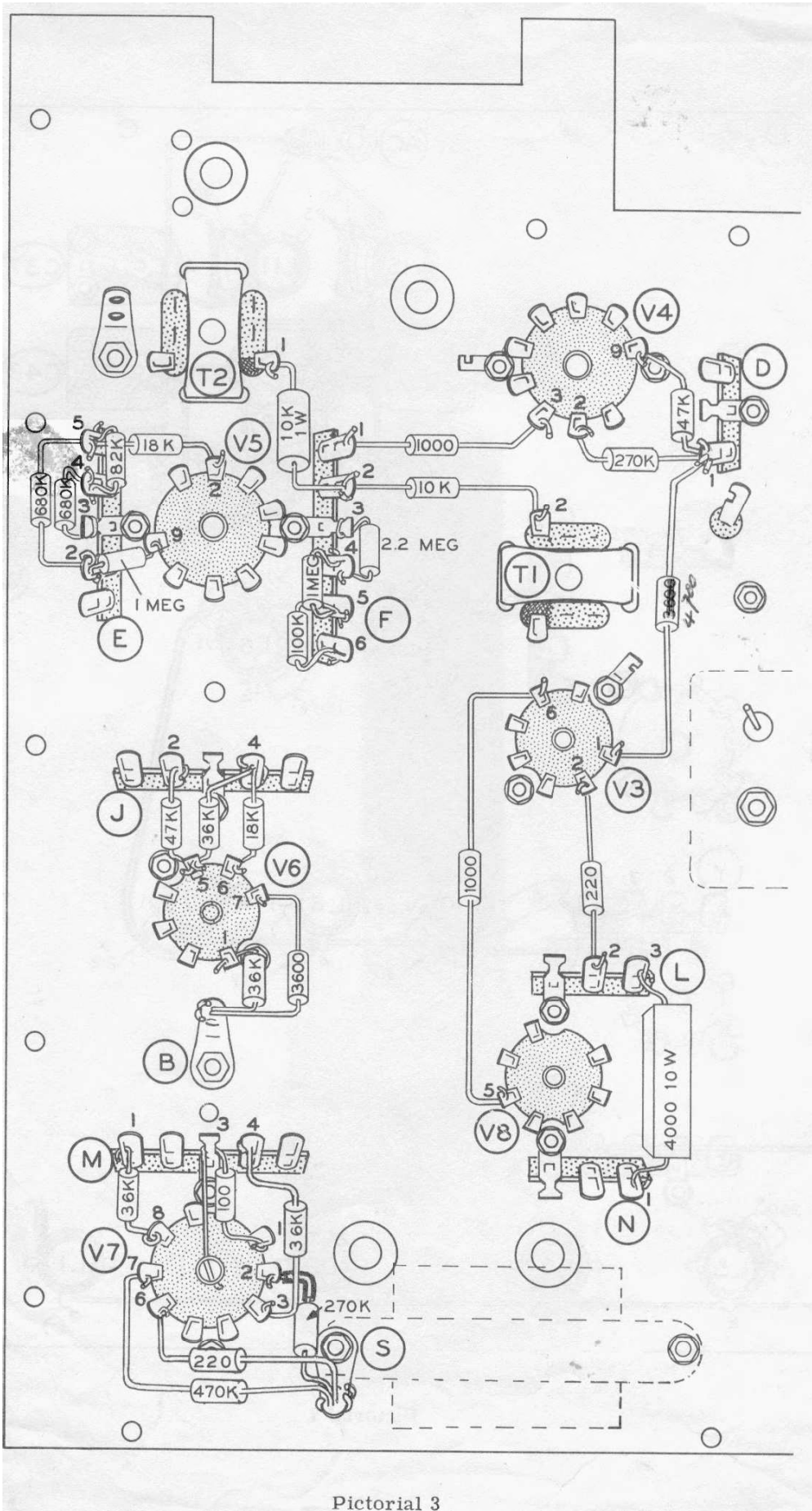

Pictorial 3

- () C66. Connect the lead on the positive (+) end of a 10 μ fd 10 V electrolytic capacitor to lug 6 of V7 (S-2). Connect the other lead to solder lug S (S-4).
- () C57. Connect the lead on the marked end of the .5 μ fd tubular capacitor to lug 1 of terminal strip E (S-2). Connect the other lead to lug 5 of terminal strip F (S-4).
- () L19. Connect a 1 mh RF choke (#45-3) from lug 1 of terminal strip J (S-4) to lug 2 of V6 (S-3).

NOTE MARKING ON TUBULAR CAPACITOR EITHER SHOULDER OR BAND MARKED END MUST BE PLACED AS SHOWN IN THE PICTORIAL

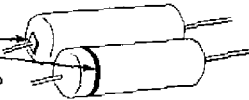

RESISTORS-RF AND MIXER STAGES

Refer to Pictorial 5 for the following steps.

Connect and position the following 1/2 watt resistors as shown in Pictorial 5.

VALUE	FROM LUG	TO LUG
() R14. 10 K Ω (brown-black-orange)	1 of terminal strip X (S-2)	4 of terminal strip X (NS).
() R15. 33 K Ω (orange-orange-orange)	9 of V2 (NS)	2 of terminal strip W (NS).
() R4. 1000 Ω (brown-black-red)	1 of terminal strip Y (NS)	6 of V1 (NS).
() R9. 3600 Ω (orange-blue-red)	2 of terminal strip Y (NS)	6 of V2 (S-2).
() R8. 10 K Ω (brown-black-orange)	3 of V2 (NS)	1 of terminal strip Y (S-4).
() R6. 470 K Ω (yellow-violet-yellow)	2 of V2 (NS)	3 of terminal strip Y (NS).
() R2. 220 Ω (red-red-brown)	2 of V1 (NS)	1 of terminal strip Z (S-2).
() R1. 470 K Ω (yellow-violet-yellow)	1 of V1 (NS)	3 of terminal strip Z (NS).
() L18. Connect a parasitic choke (#45-43) from lug 2 (NS) to lug 5 (NS) of terminal strip X.		
() L16. Connect the remaining parasitic choke from lug 4 of terminal strip Y (NS) to lug 5 of V1 (S-1). Make sure the choke does not touch any adjacent parts or wiring.		
() R7 and C23. Connect a .005 μ fd disc ceramic capacitor across a 220 Ω (red-red-brown) 1/2 watt resistor as shown in Detail 5A. Connect the lead at one end of this combination to lug 7 of V2 (S-1). Insert the other lead through lug 1 (NS) to lug 2 (S-3) of terminal strip W. Now solder lug 1 of terminal strip W (S-2).		

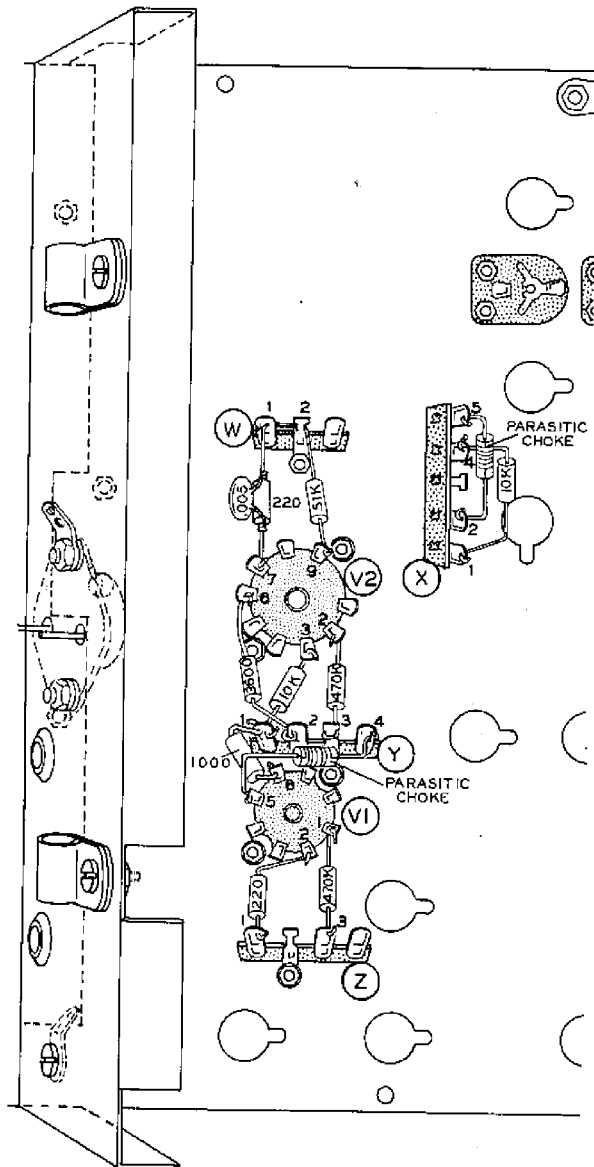

Pictorial 5

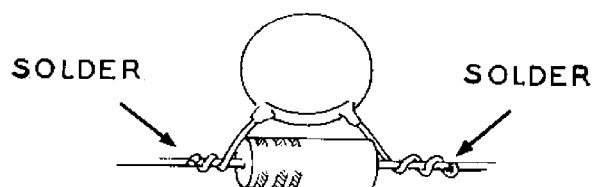

Detail 5A



CAPACITORS-RF AND MIXER STAGES

Refer to Pictorial 6 for the following steps.

Connect and position the following capacitors in an upright position, perpendicular to the chassis, as shown in Pictorial 6.

<u>VALUE-TYPE</u>	<u>FROM LUG</u>	<u>TO LUG</u>
() C32. 100 $\mu\mu\text{f}$ mica	3 of terminal strip X (S-1)	4 of terminal strip X (NS).
() C35. 100 $\mu\mu\text{f}$ mica	1 of V2 (NS)	2 of terminal strip X (S-2).
() C77. 2.2 $\mu\mu\text{f}$ phenolic tubular (red-red-white)	1 of V2 (NS)	2 of V2 (NS).
() C22. 100 $\mu\mu\text{f}$ mica	2 of V2 (S-3)	4 of terminal strip Y (NS).
() C78. 100 $\mu\mu\text{f}$ mica	9 of V2 (S-2)	3 of terminal strip W (NS).
() C24. .01 μfd disc ceramic	3 of V2 (S-2)	3 of terminal strip Y (NS).
() C25. .005 μfd disc ceramic	2 of terminal strip Y (NS)	3 of terminal strip Y (NS).
() C8. .01 μfd disc ceramic	6 of V1 (S-2)	3 of terminal strip Y (NS).
() C4. 30 $\mu\mu\text{f}$ mica	1 of V1 (S-2)	4 of terminal strip Z (NS).
() C5. .005 μfd disc ceramic	2 of terminal strip Z (NS)	3 of terminal strip Z (S-3).
() C6. .01 μfd disc ceramic	2 of V1 (S-2)	2 of terminal strip Z (NS).
() C3. 7.5 $\mu\mu\text{f}$ mica	2 of terminal strip Z (S-3)	4 of terminal strip Z (NS).
() L17. Connect a 1 mh choke (#45-3) from lug 1 of V2 (S-3) to lug 4 of terminal strip X (S-3).		ceramic capacitor to 5/8". Connect one lead to lug 3 of terminal strip Y (S-5). Leave the other lead free as shown.
() C1. Connect a .1 μfd disc ceramic capacitor between lug 5 (S-3) and the center post (S-2) of tube socket V2.		Carefully examine all the wiring done up to this time for accidental short circuits. Check all component leads, lugs of tube sockets, and check between terminal strip lugs. Make sure all connections that are soldered are soldered securely.
() R5. Cut both leads of a 3600 Ω (orange-blue-red) 1/2 watt resistor to 3/4". Connect one lead to lug 2 of terminal strip Y (S-4). Leave the other lead free as shown in Pictorial 6.		COIL WIRING
() C17. Cut both leads of a .01 μfd disc ce-		Refer to Pictorial 7 (fold-out from Page 24) for the following steps.

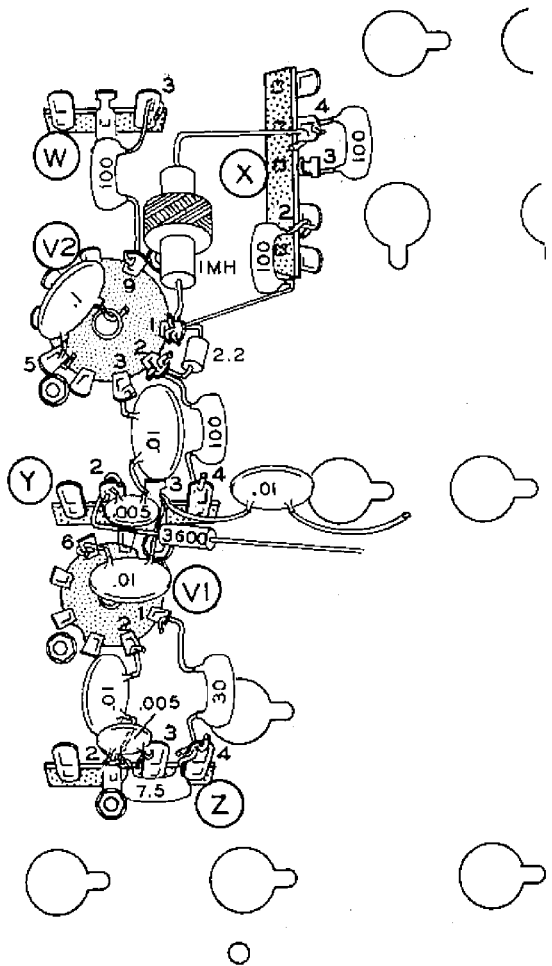

Pictorial 6

Form and position the following lengths of #20 (small) bare wire for the trimmer capacitors as shown.

- () Connect a 1-1/2" bare wire from solder lug AC (NS) to lug 2 of C37 (NS).
- () Connect a 2-1/4" bare wire to lug 2 of C37 (S-2). See that this wire touches lug 2 of C43 (NS) and then connect the other end to lug 2 of C40 (S-1).
- () Connect a 1-3/4" bare wire from lug 2 of C49 (NS), through lug 2 of C46 (NS), to lug 2 of C43 (S-3).

NOTE: The oscillator, mixer, and antenna coils have the letters O, M, and A, respectively, marked on them. Install coils on the chassis top plate as indicated in the following steps. Make sure the mounting tabs are inserted in the slots of the mounting holes. See Detail 7A. As you mount a coil, push down on it until the tabs click firmly into place. Do not turn any of the coil slugs at this time.

Detail 7A

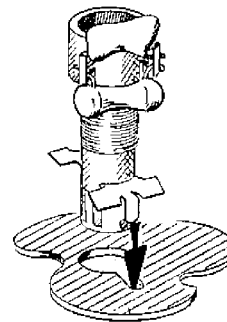

<u>COIL</u>	<u>LOCATION</u>
() O80	L15
() O10	L11
() O40	L14
() O20	L13
() O15	L12
() M40	L9
() M10	L6
() M80	L10
() M20	L8
() M15	L7
() A40	L4
() A80	L5
() A20	L3
() A15	L2
() A10	L1

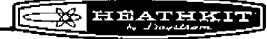

Connect the following capacitor leads to the coils and position them as shown in Detail 7A. Keep the capacitor leads as short as possible and cut off the excess lead lengths. See Pictorial 7 for the coil lug numbers and general component positioning.

<u>VALUE-TYPE</u>	<u>BETWEEN LUGS</u>
() C50. 25 $\mu\mu\text{f}$ (red-green-black) tubular ceramic	1 (NS) and 2 (NS) of L15.
() C48. 50 $\mu\mu\text{f}$ mica	1 (NS) and 2 (NS) of L15.
() C38. 25 $\mu\mu\text{f}$ (red-green-black) tubular ceramic	1 (NS) and 2 (NS) of L11.
() C36. 90 $\mu\mu\text{f}$ mica	1 (NS) and 2 (NS) of L11.
() C47. 25 $\mu\mu\text{f}$ (red-green-black) tubular ceramic	1 (NS) and 2 (NS) of L14.
() C45. 50 $\mu\mu\text{f}$ mica	1 (NS) and 2 (NS) of L14.
() C44. 50 $\mu\mu\text{f}$ (green-black-black) tubular ceramic	1 (NS) and 2 (NS) of L13.
() C42. 220 $\mu\mu\text{f}$ mica	1 (NS) and 2 (NS) of L13.
() C41. 50 $\mu\mu\text{f}$ (green-black-black) tubular ceramic	1 (NS) and 2 (NS) of L12.
() C39. 290 $\mu\mu\text{f}$ mica	1 (NS) and 2 (NS) of L12.
() C19. 50 $\mu\mu\text{f}$ mica	3 (S-1) and 4 (NS) of L9.
() C18. 30 $\mu\mu\text{f}$ mica	1 (NS) and 2 (NS) of L9.
() C12. 150 $\mu\mu\text{f}$ mica	3 (S-1) and 4 (NS) of L6.
() C11. 50 $\mu\mu\text{f}$ mica	1 (NS) and 2 (NS) of L6.
() C20. 30 $\mu\mu\text{f}$ mica	1 (NS) and 4 (NS) of L10.
() C16. 50 $\mu\mu\text{f}$ mica	2 (NS) and 3 (S-1) of L8.
() C15. 50 $\mu\mu\text{f}$ mica	1 (NS) and 4 (NS) of L8.
() C14. 50 $\mu\mu\text{f}$ mica	2 (NS) and 3 (S-1) of L7.
() C13. 22 $\mu\mu\text{f}$ mica	1 (NS) and 4 (NS) of L7.
() C2. 390 $\mu\mu\text{f}$ mica	1 (S-1) and 4 (NS) of L5.

- () Connect the free end of the 3600 Ω (orange-blue-red) 1/2 watt resistor coming from lug 2 of terminal strip Y to lug 4 of L10 (NS).
- () Connect the free end of the .01 μ fd disc ceramic capacitor coming from lug 3 of terminal strip Y to lug 4 of L10 (NS).

Use only #20 bare wire in the following steps. Connect and position each wire as shown in Pictorial 7.

<u>LENGTH</u>	<u>FROM LUG</u>	<u>TO LUG</u>
() 1-1/4"	2 of L15 (S-3)	solder lug AC (NS).
() 1-1/4"	2 of L11 (S-3)	solder lug AC (S-3).
() 1-1/4"	1 of L15 (NS)	1 of C49 (S-1).
() 1-1/4"	1 of L11 (NS)	1 of C37 (S-1).
() 1-1/8"	2 of L14 (S-3)	2 of C49 (S-2).
() 1-1/8"	2 of L13 (S-3)	2 of C46 (S-3).
() 1"	2 of L12 (S-3)	#20 bare wire directly below 2 of L12 (S-1).
() 2"	1 of C46 (S-1)	1 of L14 (NS).
() 2"	1 of C43 (S-1)	1 of L13 (NS).
() 1"	1 of L12 (NS)	1 of C40 (S-1).

- () Insert one end of a 5-3/4" bare wire through lugs 4 of L7 (NS), 4 of L8 (NS), to lug 4 of L10 (S-4). Now solder lugs 4 of L8 (S-3) and 4 of L7 (S-3). Place 2-1/2" of sleeving over the other end of this wire and insert it through lug 2 of L6 (NS) to lug 2 of L9 (S-2). Solder lug 2 of L6 (S-3).
- () Insert one end of a 5-1/4" bare wire through lugs 2 of L1 (NS), 2 of L2 (NS), 2 of L3 (NS), 2 of L5 (NS), to solder lug AB (NS). Now solder lugs 2 of L1 (S-1), 2 of L2 (S-2), 2 of L3 (S-2), and 2 of L5 (S-2).
- () Connect a 2-1/2" bare wire from lug 2 of L4 (S-1) to solder lug AB (S-2).

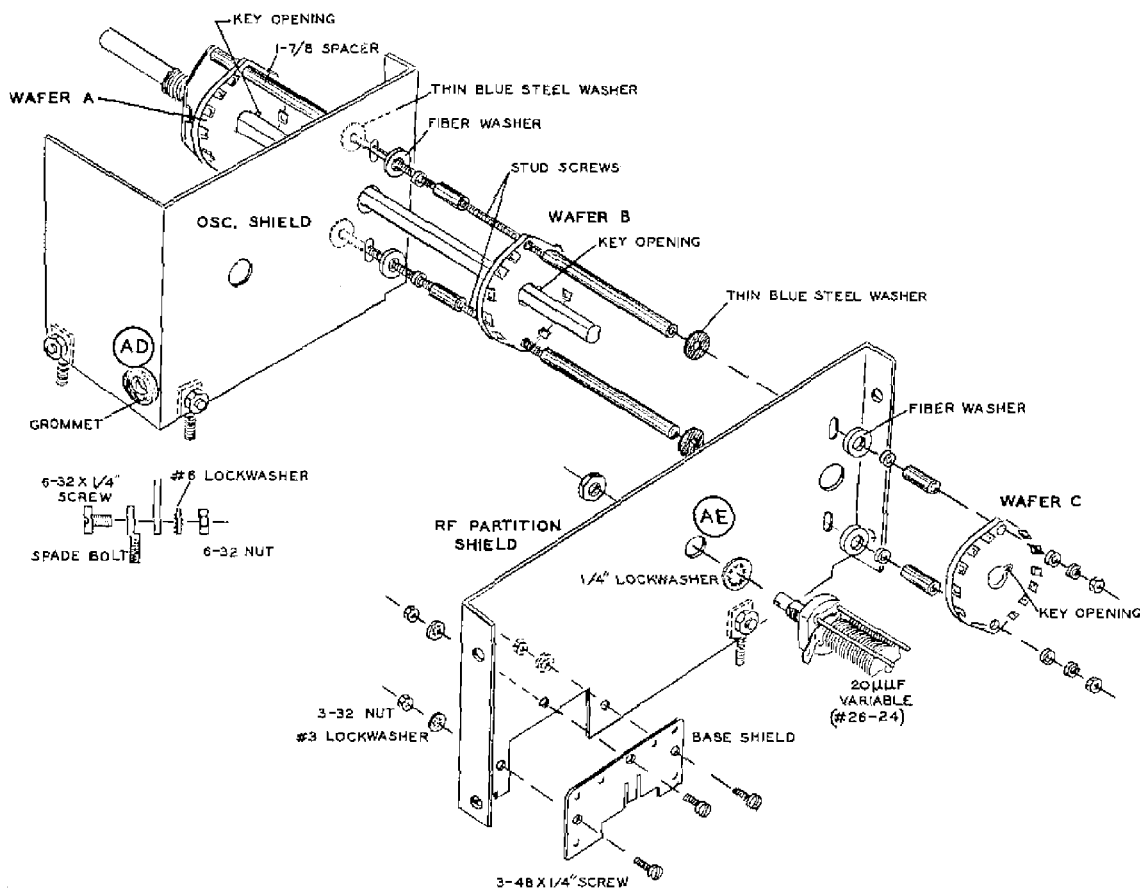

Detail 8A

BAND SWITCH ASSEMBLY

Refer to Detail 8A for the following steps.

- () Install two spade bolts to the bottom of the oscillator shield and one spade bolt to the RF partition shield as shown in Detail 8A. Use 6-32 x 1/4" screws, #6 lockwashers, and 6-32 nuts.
- () Install a rubber grommet at AD on the oscillator shield.
- () Mount the 7-pin tube base shield to the RF partition shield, using 3-48 x 1/4" screws, #3 lockwashers, and 3-48 nuts.
- () C79. Mount the 20 μf (#26-24) variable capacitor to the RF partition shield at AE, using a 1/4" lockwasher and the capacitor nut as shown.
- () Carefully study Detail 8A. Take the BAND switch and remove the two nuts on the switch stud screws. Disassemble the switch parts up to the 1-7/8" spacers in front of wafer A. Lay these parts to one side so that they may be reassembled in the same order as they were removed.
- () Place a thin blue steel washer on each of the switch stud screws.

- () Place the oscillator shield (#206-M186) on the BAND switch as shown in Detail 8A. Place fiber washers on the studs as shown. Reassemble the switch parts up to the RF partition shield. Make sure that wafer B and the key opening are positioned exactly as wafer A.
- () Again place a thin blue steel washer on each of the switch stud screws.
- () Install the RF partition shield (#206-M185), the remaining switch parts, and fiber washers as shown. Again make sure that wafer C is installed exactly like the other two switch wafers. Tighten the nuts on the studs carefully (not excessively) while making sure nothing binds or is forced out of position.
- Refer to Pictorial 8 for the following steps.
- () Remove the #6 hardware from the one cable clamp for the RF shield placement. See Pictorial 8.
- () Carefully mount the BAND switch assembly to the chassis top plate and base center section as shown in Pictorial 8. Make sure the tube base shield is placed on tube socket V1. Use #6 lockwashers and 6-32 nuts on the spade bolts. Reinstall the cable clamp and its #6 hardware along with #6 hardware installed in the hole directly below the cable clamp. Tighten the two mounting screws of the chassis base center section to the chassis top plate. It may be necessary to bend the tube base shield to keep it clear of the tube socket lugs to prevent short circuiting.
- () Solder the tube base shield to the center post of V1.

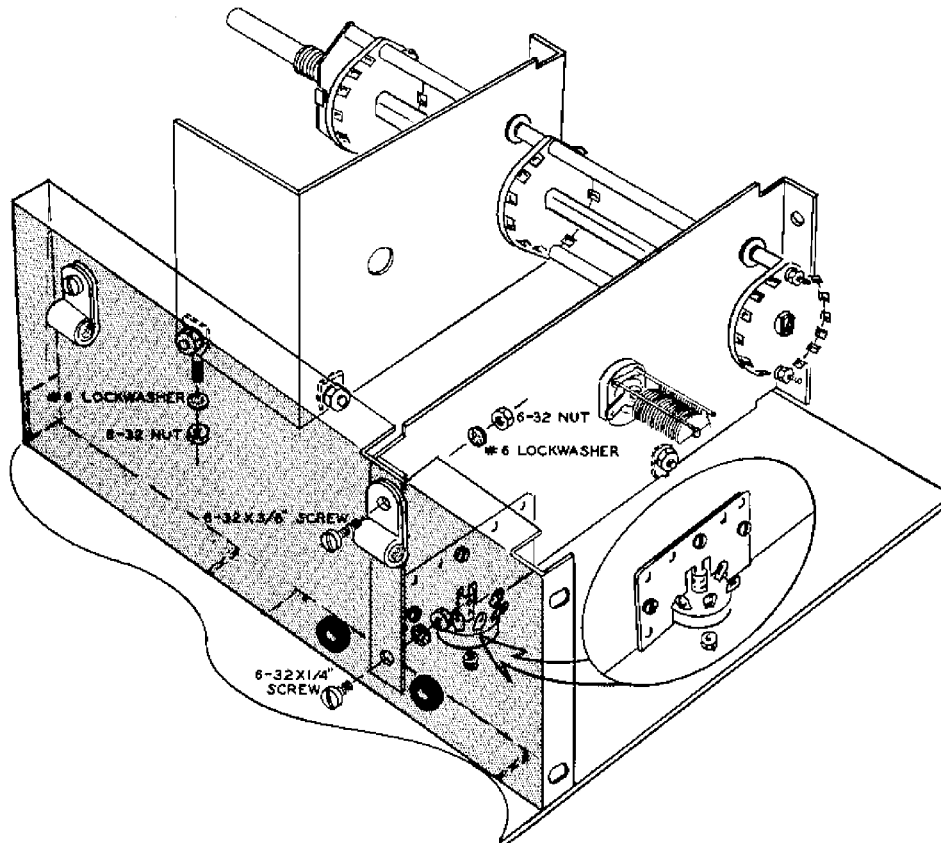

Pictorial 8



WIRING THE BAND SWITCH

Refer to Pictorial 9 for the following steps.

- () C10. Connect a 680 μf mica capacitor between lugs 6 (S-1) and 7 (NS) of wafer B of the BAND switch.

In the following steps, #16 (heavy) bare wire, green wire, and blue wire will be used. Use green wire with the antenna coils and use blue wire with the mixer coils.

Form and route each #16 bare wire as shown in Pictorial 9, then make the connections as directed. Make sure none of the bare wires touch adjacent parts or other wiring. Do not crimp the ends of the heavy bare wire.

<u>LENGTH-TYPE</u>	<u>FROM LUG (BAND SWITCH)</u>	<u>TO COIL LUG</u>
() 5-3/4" #16	7 of wafer A (S-1)	use sleeving and leave free.
() 3-3/8" #16	6 of wafer A (S-1)	3 of L15 (S-1).
() 1" #16	8 of wafer A (S-1)	1 of L11 (S-4).
() 3-1/2" #16	5 of wafer A (S-1)	3 of L14 (S-1).
() 3" #16	4 of wafer A (S-1)	3 of L13 (S-1).
() 2-7/8" #16	2 of wafer A (S-1)	3 of L11 (S-1).
() 4-3/4" blue	7 of wafer B (S-2)	4 of terminal strip Y (S-3).
() 3/4" blue	8 of wafer B (S-1)	1 of L6 (S-2).
() 3-1/4" blue	5 of wafer B (S-1)	4 of L9 (S-2).
() 3" blue	4 of wafer B (S-1)	2 of L8 (S-2).
() 2-3/8" green	7 of wafer C (S-1)	2 of capacitor AE (NS).
() 2-3/4" green	2 of capacitor AE (S-2)	4 of terminal strip Z (S-3).
() 4-5/8" green	6 of wafer C (S-1)	3 of L5 (S-2).
() 1-1/8" green	8 of wafer C (S-1)	1 of L1 (S-1).
() 4" green	5 of wafer C (S-1)	3 of L4 (S-1).
() 1-3/4" green	2 of wafer C (S-1)	3 of L1 (S-1).
() 2-1/4" green	9 of wafer C (S-1)	1 of L2 (S-1).

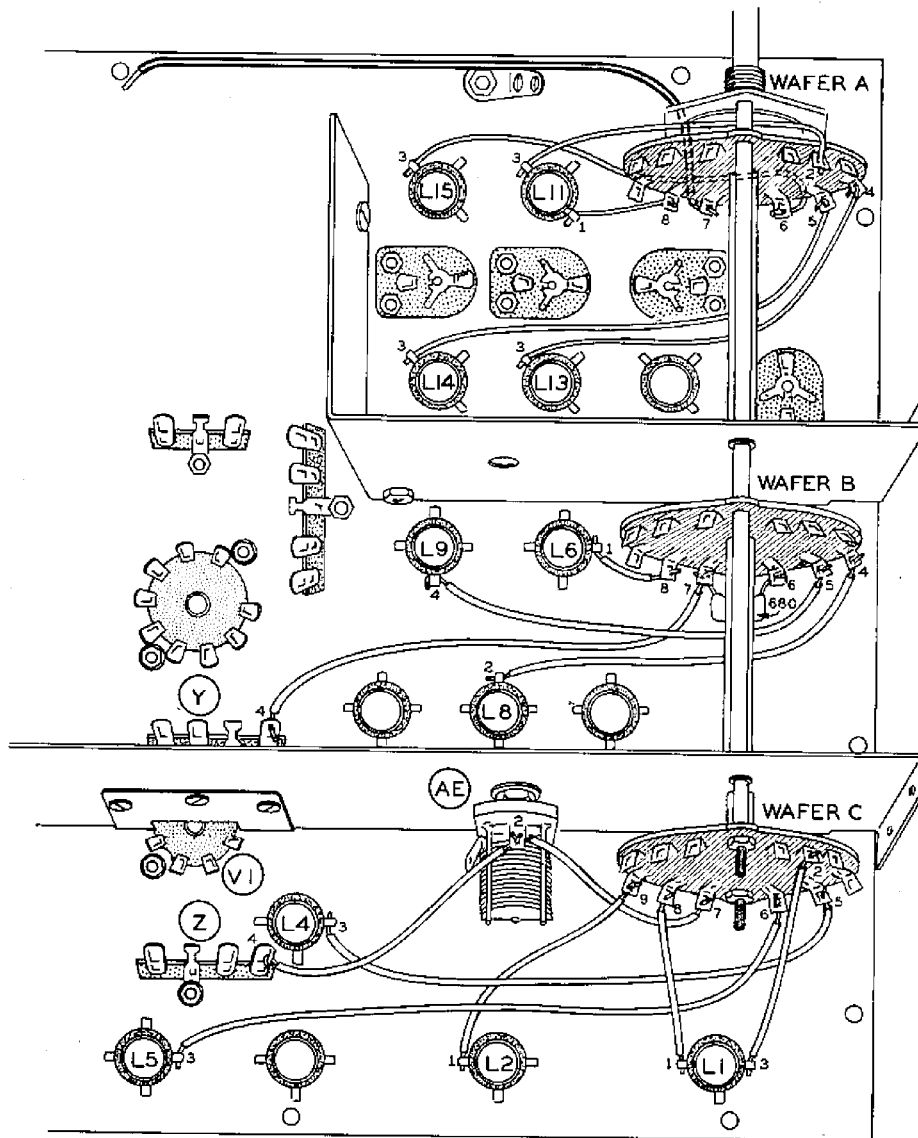

Pictorial 9



Refer to Pictorial 10 for the following steps.

Use the same procedure as employed in the previous steps. Be sure to allow room, when routing some of the wires, for the shaft to be inserted through the oscillator shield to capacitor CE later.

<u>LENGTH-TYPE</u>	<u>FROM LUG (BAND SWITCH)</u>	<u>TO COIL LUG</u>
() 2-1/4" #16	3 of wafer A (S-1)	3 of L12 (S-1).
() 6" #16	1 of wafer A (S-1)	through grommet AD to lug 5 of terminal strip X (S-2). Use sleeving.
() 2-1/4" #16	9 of wafer A (S-1)	1 of L12 (S-4).
() 2-1/8" #16	10 of wafer A (S-1)	1 of L13 (S-4).
() 3-1/8" #16	11 of wafer A (S-1)	1 of L14 (S-4).
() 2-3/8" #16	12 of wafer A (S-1)	1 of L15 (S-4).
() 2-1/4" blue	3 of wafer B (S-1)	2 of L7 (S-2).
() 1-3/4" blue	9 of wafer B (S-1)	1 of L7 (S-2).
() 2-3/8" blue	2 of wafer B (S-1)	4 of L6 (S-2).
() 1-7/8" blue	10 of wafer B (S-1)	1 of L8 (S-2).
() 2" blue	11 of wafer B (S-1)	1 of L9 (S-2).
() 3-1/8" blue	12 of wafer B (S-1)	1 of L10 (S-2).
() 4" green	4 of wafer C (S-1)	3 of L3 (S-1).
() 2-5/8" green	3 of wafer C (S-1)	3 of L2 (S-1).
() 3-3/4" green	10 of wafer C (S-1)	1 of L3 (S-1).
() 3-7/8" green	11 of wafer C (S-1)	1 of L4 (S-1).
() 4-3/4" green	12 of wafer C (S-1)	4 of L5 (S-2).

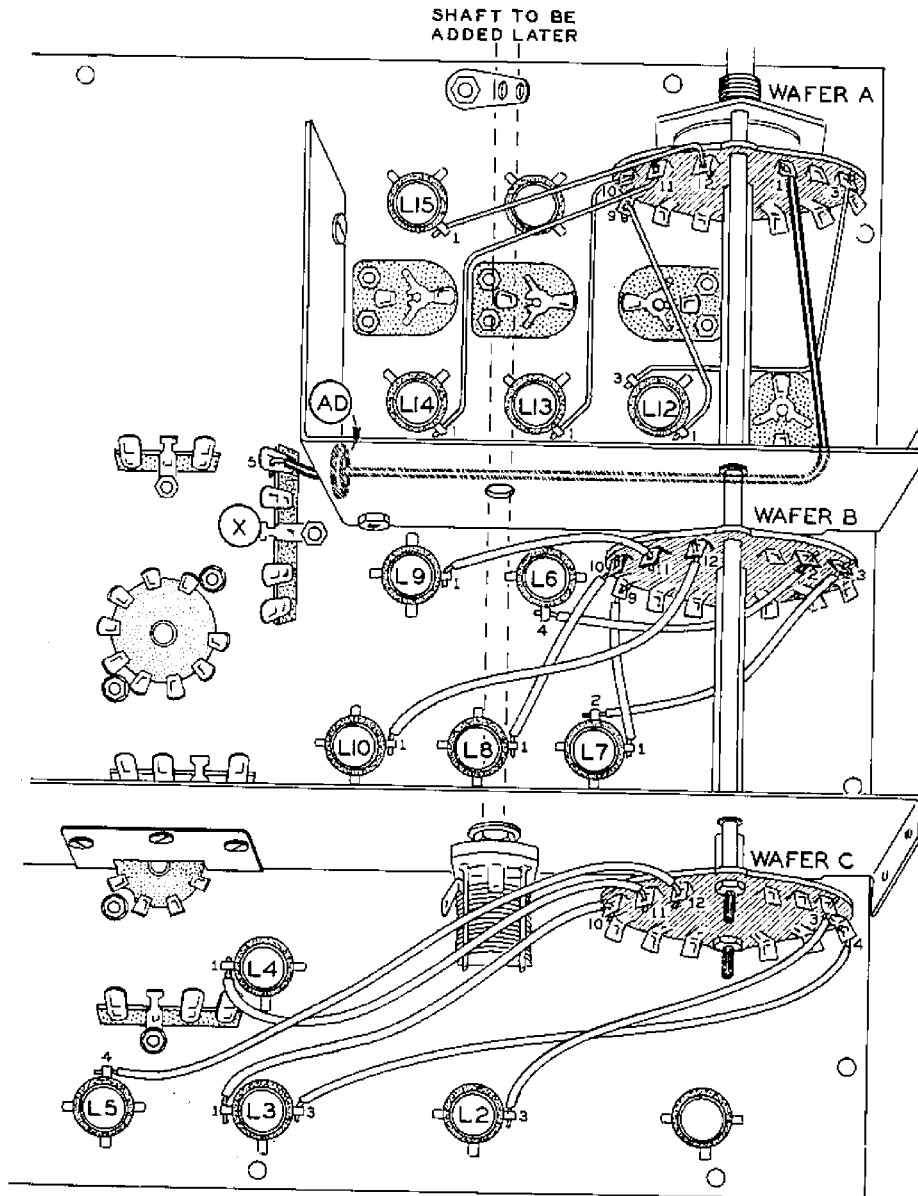

Pictorial 10

MAIN TUNING MECHANISM ASSEMBLY

Refer to Pictorial 11 (fold-out from Page 39) for the following steps.

Most of the following steps are keyed to Pictorial 11 by circled numbers. Follow the steps carefully and refer to Pictorial 11 as each part is installed.

- ① () Locate and position the main dial plate (#100-M212) assembly as shown.
 - ② () Mount the top plate bracket (#204-M213) to the main dial plate with 6-32 x 3/8" screws, #6 lockwashers, and 6-32 nuts. Also install a cable clamp positioned at AJ as shown. The screws should be tightened temporarily (so that the shaft can be aligned later) at their center position in the slotted holes.
 - ③ () Mount one end of the two dial plate spacers to the main dial plate. Use 6-32 x 1/4" screws, #6 lockwashers, and #6 flat washers.
- () Locate the 5-25 μ mf, 2-section variable capacitor (#26-52) and bend the four lugs to the position shown in Detail 11A. CAUTION: Do not bend rotor lug. Make sure the plates are fully meshed to prevent any possible damage.

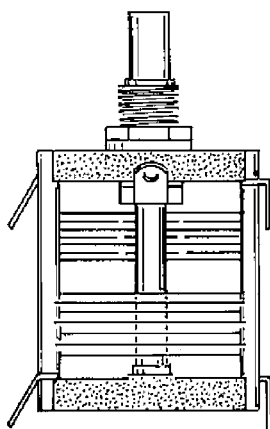

Detail 11A

- ④ () Tighten the control nut that is already furnished on the capacitor shaft and place a control lockwasher over the shaft. Insert the capacitor shaft through the indicated hole of the main dial plate and secure it with a control nut.

- ⑤ () Place the antibacklash gear (#451-16) on the capacitor shaft as shown. Tighten the gear to the shaft, using an 8-32 x 1/4" setscrew.
- ⑥ () Locate the pointer drive pulley shaft assembly (#100-202); the one with the largest gear attached.
- ⑦ () Locate the tuning drive gear (#451-15) and insert an 8-32 x 1/8" setscrew in the bushing. Slide this gear on the pointer drive pulley shaft assembly spaced 9/32" from the shaft end, with the hub facing the hub of the large gear. Temporarily tighten the setscrew.
- ⑧ () Place a brass spring washer over the shaft and adjacent to the large gear of the pointer drive pulley shaft assembly. Place this assembly (tuning drive gear first) in the main dial plate as shown. Let the tuning drive gear mesh with only the first half of the anti-backlash gear. Now rotate the other half of the anti-backlash gear two full teeth forward, then slide the tuning drive gear down so that it is resting on the bushing flange.
- ⑨ () Locate the pinion gear shaft assembly (#100-201). Place an E washer in the groove, and mount the shaft with this E washer against the bushing flange as indicated. Place a brass spring washer over the other end of the shaft.
- ⑩ () Place the end of the nylon cluster gear pivot shaft (#453-78) with shorter stub through the nylon cluster gear (#451-12) as shown in the insert of Pictorial 11. Now place this short stubbed end of the pivot shaft, with a nylon washer over it, in the hole of the main dial plate as indicated. The small nylon gear should be in mesh with the large pointer drive gear and pinion gear.
- ⑪ () Locate the front dial plate assembly (#100-M213) and install the special 6-32 x 3/16" fillister head screw as shown, using a #6 lockwasher and 6-32 nut.
- ⑫ () Locate the cluster gear tension spring and mount it on the front dial plate, using a 5-40 hex shoulder screw and 5-40 nut as shown. Bend the length of

spring that projects through its mounting hole so that it points directly away from the 5-40 hex shoulder screw.

- ⑬ () Position the front dial plate as shown, then slide it over the shafts until the plate seats firmly in the ends of the spacers that protrude from the main dial plate. Fasten the plate to the spacers with 6-32 x 1/4" screws, #6 lockwashers and #6 flat washers. Make sure the end of the cluster gear pivot shaft is in its slotted hole.
- () Using pliers, carefully place the end of the tension spring over the end of the cluster gear pivot shaft and let it rest in the shaft groove. This will provide sufficient tension to hold the nylon gear in mesh with the other two gears.
- () Rotate the pinion gear shaft (the long protruding shaft) counterclockwise until the largest gear reaches its stop. Loosen the tuning drive gear setscrew and close the plates of the tuning capacitor to full mesh. Now, permanently tighten the setscrew, being very careful to maintain the anti-backlash gear spring tension.
- NOTE: It is recommended (but not mandatory) at this time that all of the gears be lubricated for smooth and easy tuning operation. Only small amounts of the silicone types of grease should be used, however, for the desired results.
- ⑭ () Locate the pointer drive pulley assembly (#100-M165), 1-3/4" diameter and start an 8-32 x 1/4" setscrew into the bushing. Place this pulley on the pointer drive pulley shaft so that the pulley bushing rides lightly on the neck of the bushing in the front dial plate. Tighten the setscrew.
- ⑮ () Locate the two dial drum support bracket assemblies (#100-M132). Mount each bracket to the main dial plate as shown using 6-32 x 3/8" screws, #6 lockwashers, and 6-32 nuts. Slide the two brackets fully away from each other in the slotted mounting holes when tightening. Do not tighten excessively at this time.
- ⑯ () Install a 1/4" x 1/4" shaft bushing (#455-6) in each dial drum support bracket, from the bracket flange side, with a thin control lockwasher and control nut. Tighten securely.
- ⑰ () Install two pilot lamp sockets (back-to-back) on the main dial plate as shown. Use a 6-32 x 3/8" screw, two #6 lockwashers, and a 6-32 nut. Rotate the socket lugs and then bend them to the position shown in the insert in Pictorial 11.
- ⑱ () Install a #44 pilot lamp in each pilot lamp socket. Place shrouds over the pilot lamps as shown.
- ⑲ () Locate the dial drum plug button assembly (#100-M125) and place it firmly in the left end of the dial drum (#464-24) (the left end has the lowest frequency reading). If you are unable to obtain a firm fit, spread the button fingers slightly to insure proper internal tension against the dial drum. Position plug assembly so that the setscrew is in line with the words Model "HR-20."
- ⑳ () Install the dial drum plug button (#485-M7) on the other end of the dial drum.
- ㉑ () Locate the dial drum shaft assembly (#100-M200). Slide the long end through the right end plug button, through the dial drum, then through the bushing of the left end plug button. Start a 6-32 x 1/4" setscrew in the bushing on the left end plug button, but do not tighten yet.
- () Loosen the screws of the two dial drum support brackets and place the dial drum (with its scale as shown) between the two brackets. Slide the brackets toward each other with the ends of the dial drum shaft placed in their respective bushings. With the brackets positioned fully toward each other and the dial drum exactly parallel with the top edge of the main dial plate, tighten the bracket screws securely.

- ②② () From the outside and top edge of each dial drum support bracket, mount a spade bolt with 6-32 x 1/4" screws, #6 lockwashers, and 6-32 nuts as shown.
- ②③ () Locate the dial pointer bracket (#204-M215) and place it on top of the spade bolts as shown. Secure this bracket with a #6 lockwasher and 6-32 nut at each end. If the dial drum is binding, loosen the setscrew in the bushing of the dial drum plug button. Retighten the setscrew when the drum rotates freely.
- () Move the dial drum shaft with pulley to the right so that the pulley is resting against the bushing flange. Then move the dial drum to the left so that the plug button bushing rides against the left support bracket bushing. Tighten the setscrew when the drum rotates freely and does not have any unnecessary lateral motion.

Refer to Detail 11B for the following steps.

- () Turn the dial so the capacitor is fully meshed and use the full length of dial cord supplied.

Make a small loop in one end as shown in the sequence of steps in Detail 11B. Place the loop over the hook (arrow position #1) on the drive pulley as shown. Now, following the numbered arrows, pass the cord through the pulley rim. Then proceed to the left, make one complete turn in a clockwise direction around the drive pulley, and pass the cord up around the small pulleys. Next, route the cord directly down to the bottom of the drive pulley, past the rim opening, and then make one more turn in a clockwise direction around the pulley to the rim opening.

- () Locate a dial cord spring and place one end over the pulley hook (arrow position #11).
- () Pass the free end of the dial cord through the other end of the spring. Pull the cord taut enough to stretch the spring about 1/4" and secure the cord to the spring with several overhand knots. Then cut off the balance of the cord for use later.

Set the tuning mechanism aside temporarily.

FORM A SMALL LOOP ON ONE END OF THE DIAL CORD AS SHOWN

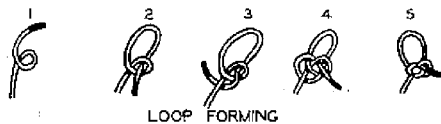

LOOP FORMING

START WITH AND STRING DIAL CORD AS SHOWN BY CONSECUTIVE ARROW HEADS

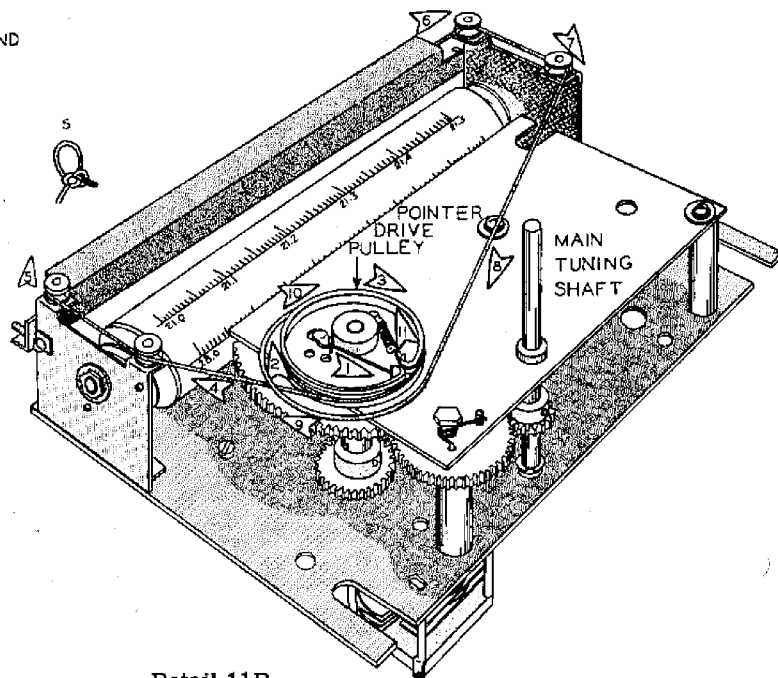

Detail 11B

INSTALLING THE NOISE LIMITER SWITCH

Refer to Pictorial 12 for the following steps.

- () Position the Noise Limiter switch (#63-194) as shown in Detail 12A. Prepare a control solder lug by clipping off 1/4" from the protruding end, and bending the end of the solder lug to a right angle, as shown. Place and position the solder lug on the switch shaft, and tighten it down temporarily with a control nut.

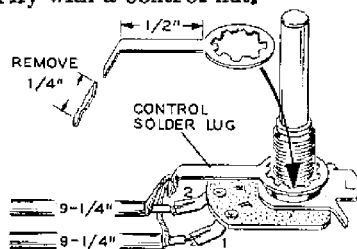

Detail 12A

- () Prepare both ends of a 9-1/4" shielded wire as previously instructed in Detail 2C on Page 19. At one end of this shielded wire, connect the inner conductor to lug 1 (S-1) and connect the shield to the solder lug (NS) of the Noise Limiter switch. Leave the other end free.
- () Prepare another 9-1/4" shielded wire as in the previous step. At one end, connect the inner conductor to lug 2 (S-1) and the shield to the solder lug (S-2) of the Noise Limiter switch.
- () Remove the control nut on the Noise Limiter switch and insert the free ends of the shielded wires through cable clamp AJ on the main dial plate of the tuning mechanism. See Pictorial 12. Slide the Noise Limiter switch fully into its mounting hole in the front dial plate as shown. Secure with a control flat washer and control nut.

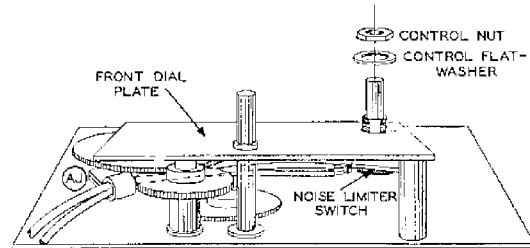

Pictorial 12

TUNING MECHANISM MOUNTING

Refer to Pictorial 13 for the following steps.

- () Place a control lockwasher on the BAND switch bushing. Now, mount the tuning mechanism assembly to the chassis top plate and chassis base center section as shown. The BAND switch should be placed fully in the slotted mounting hole of the main dial plate. Use three 6-32 x 1/4" screws, #6 lockwashers, and 6-32 nuts through the top plate bracket to the chassis top plate as shown. Use a 6-32 x 3/8" screw, large #6 solder lug, #6 lockwasher, and 6-32 nut to secure the base center section to the tuning mechanism.
- () Tighten the BAND switch to the main dial plate with a control flat washer and control nut.

Refer to Detail 13A for the following step.

- () At one end of a 7-1/2" brown and white twisted pair, strip 5/8" insulation off the brown wire and connect it to lug 1 of both pilot lamp sockets, solder both connections. Connect the white wire to lug 2 of both pilot lamp sockets (S-3). Position as shown and leave the other end free.

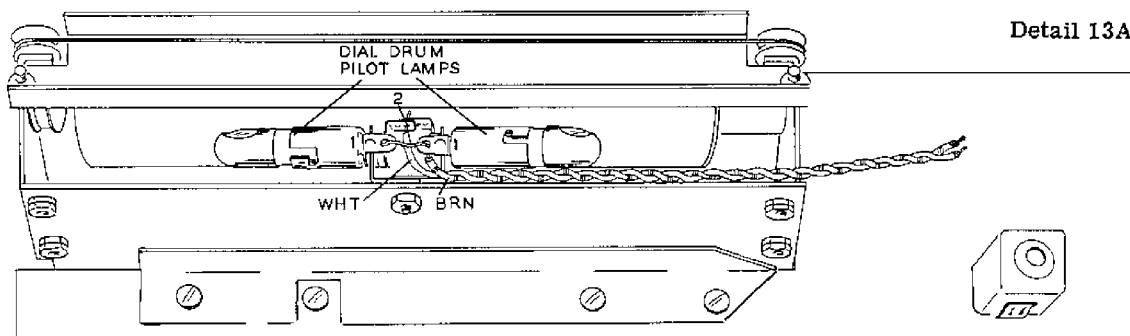

Detail 13A

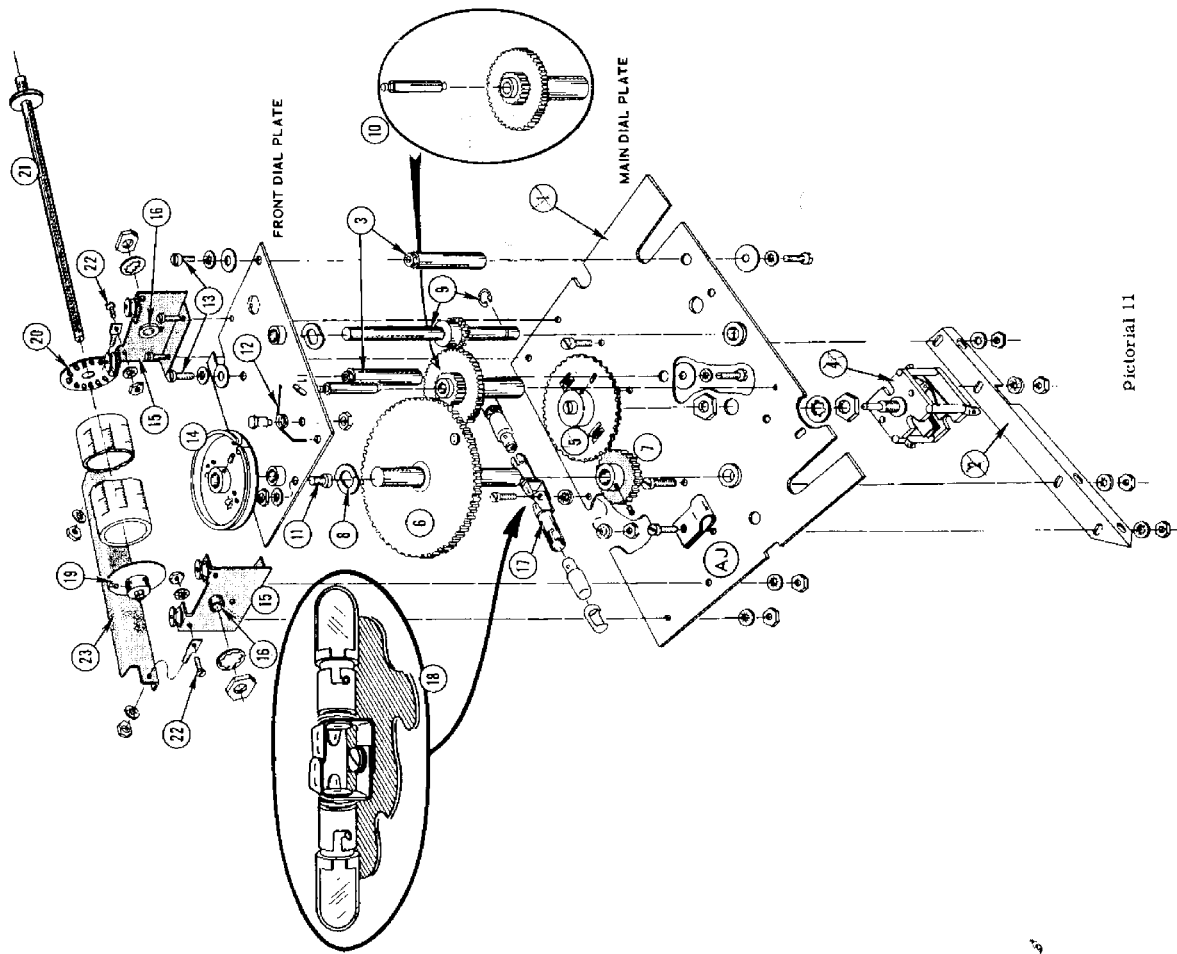

Pictorial 11

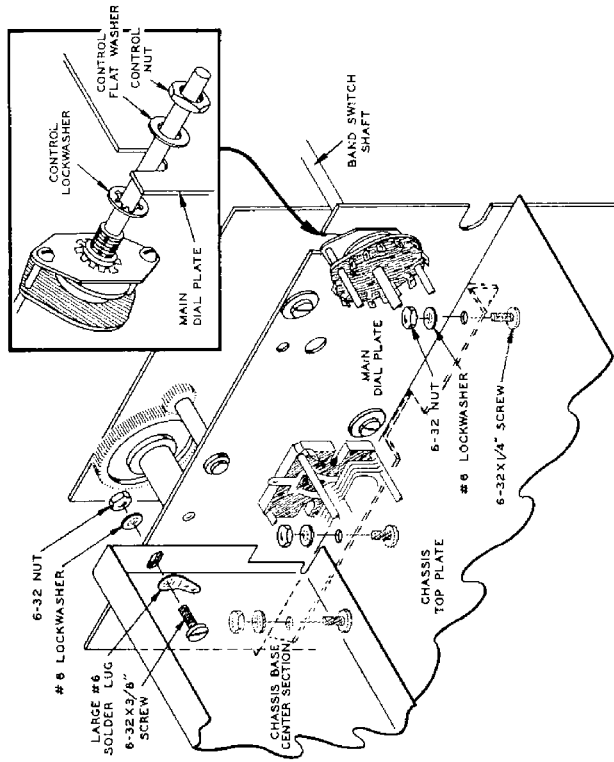

Pictorial 13

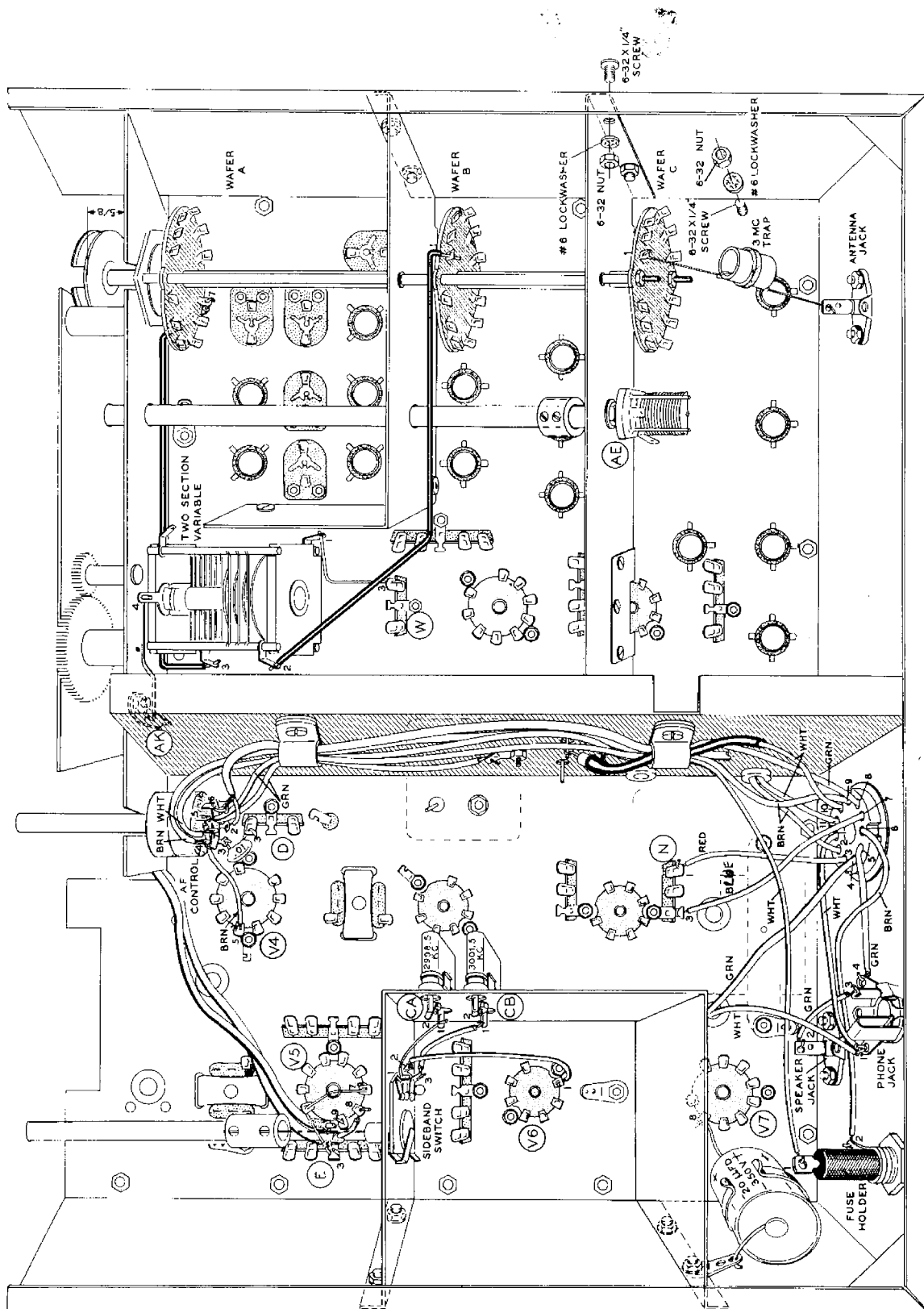

Pictorial 14

DETECTOR MOUNTING SHIELD

Refer to Pictorial 14 for the following steps.

- () Locate the product detector partition shield (#206-M184) and install two spade bolts at the bottom as shown in Detail 14A. Use 6-32 x 1/4" screws, #6 lockwashers, and 6-32 nuts.

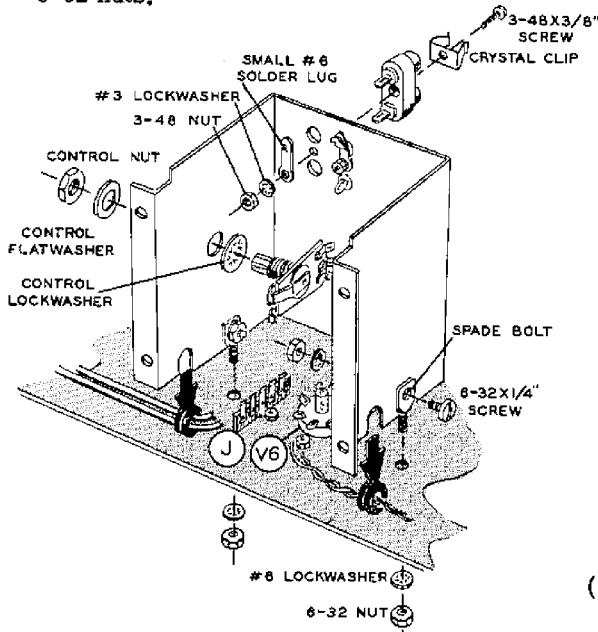

Detail 14A

- () Install two crystal sockets to the detector shield, using 3-48 x 3/8" screws, crystal clips, small #6 solder lugs, #3 lockwashers, and 3-48 nuts as shown in Detail 14A.
- () Install and position the Sideband switch (#63-177) on the detector shield, using a control lockwasher, control flat washer, and control nut. See Detail 14A.
- () Mount the detector shield assembly to the chassis top plate (around tube socket V6), with the slotted holes placed over and on the two loose grommets. Make sure none of the surrounding wires are pinched to the chassis top plate. Tighten the detector shield down with #6 lockwashers and 6-32 nuts on the spade bolts. See Detail 14A and Pictorial 14.

Set the chassis top plate assembly aside temporarily.

- () Locate the chassis base assembly (#100-M348F606).
- () Refer to Detail 14B and mount the capacitor clip to the left chassis base, using a 6-32 x 1/4" screw, #6 lockwasher and a 6-32 nut. Position as shown.

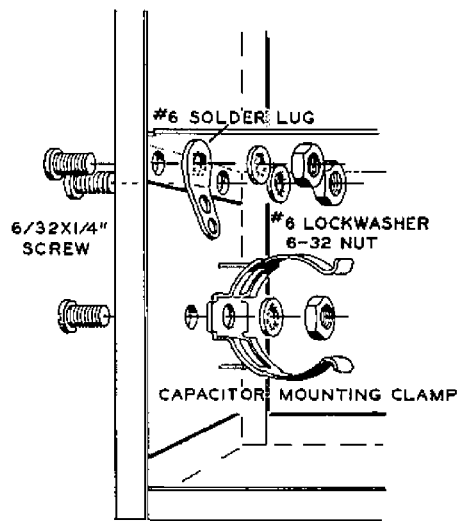

Detail 14B

- () C68. Mount the 20 μ fd 350 volt tubular electrolytic capacitor in the mounting clip with the positive (+) end down as shown (see Pictorial 14). Leave the leads free.
- () Install the fuse holder at F-1, using the hardware supplied with the fuse holder. See Pictorial 14 for lug positioning and Detail 14C for the hardware assembly. Bend lug 2 up slightly for wiring later.

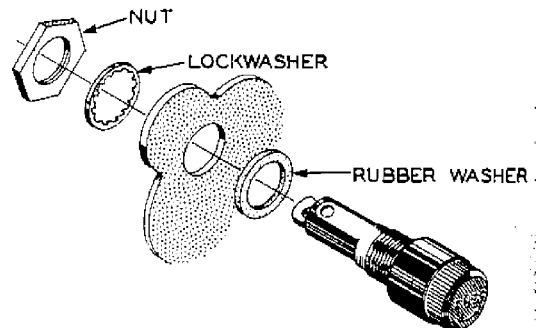

Detail 14C

- () Install the fuse in the fuse holder.
- () Install the phone jack at J-3 on the chassis base, using a control lockwasher, a control flat washer and control nut, as shown in Detail 14D. See Pictorial 14 for lug positioning.

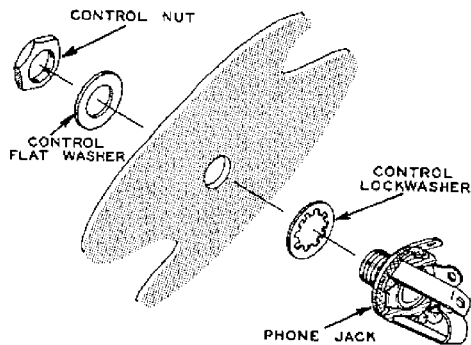

Detail 14D

- () Install the speaker phono jack at J-2 of the chassis base, using 6-32 x 1/4" screws, #6 lockwashers, and 6-32 nuts. See Pictorial 14 for lug positioning.
- () Install the 11-pin plug at P-1 of the chassis base. Use the plug ring and plug washer as shown in Detail 14E. The plug key or pins 1 and 11 should be adjacent to the lettering PWR on the chassis base.

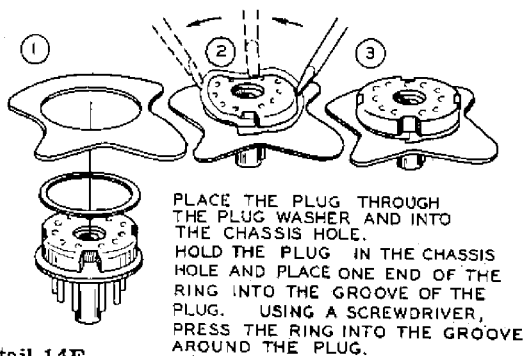

Detail 14E

- () Install the antenna phone jack at J-1 of the chassis base, using 6-32 x 1/4" screws, #6 lockwashers and 6-32 nuts.

- () Take the chassis base assembly and slide it from the rear of chassis top plate toward the front. See Pictorial 14 for the final position. Check to see that the chassis base and top plate mounting holes correspond with each other. Use #6 hardware in these mounting holes. Also secure the RF, oscillator, base center section, and detector shields and a #6 solder lug to the chassis base using #6 hardware in each of their mounting holes as shown in Pictorial 14.

- () Locate the angle bracket (#204-135). In the round hole, mount a 5-40 x 7/8" stud screw with the dial pulley (#466-7) and 1/4" spacer. Secure with two 5-40 nuts and a #6 lockwasher as shown in Detail 14F.

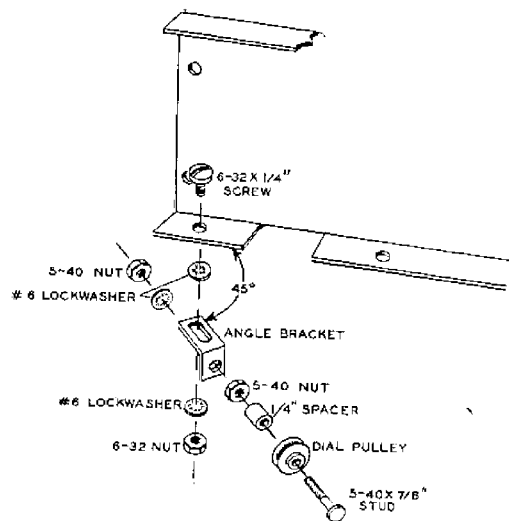

Detail 14F

- () Mount and position this angle bracket at the front of the chassis base with the approximate 45 degree relationship as shown in Detail 14F. Use #6 hardware as shown. Bend the angle bracket back so that the ends of the two screws touch each other.



WIRING THE CHASSIS BASE

Refer to Pictorial 14 for the following steps.

- () Connect the positive (+) lead of the 20 μ fd 350 V electrolytic capacitor in the mounting clip to lug 8 of tube socket V7 (S-2). Connect the other lead of the capacitor to the adjacent solder lug (S-1).
- () Connect a 1-1/2" green wire from lug 2 of the speaker jack (S-1) to lug 3 of the phone jack (S-1).
- () Connect the free end of the white audio transformer lead to lug 1 of the phone jack (NS).
- () Connect a 3-1/2" white wire from lug 1 of the phone jack (S-2) to pin 1 of the 11-pin plug (S-1). See Detail 14G.

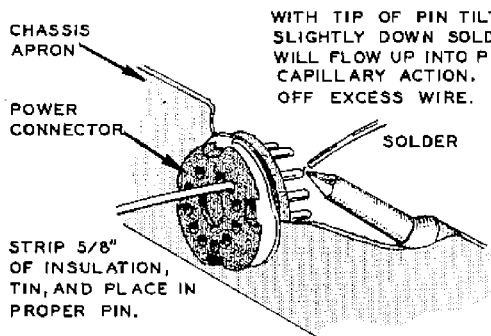

Detail 14G

- () Connect a 4" brown wire from lug 2 of the fuse holder (S-1) to pin 6 of the 11-pin plug (S-1).
- () Connect the free end of the black wire coming from lug 3 of terminal strip N to pin 7 of the 11-pin plug (S-1).
- () Connect one end of an 8-1/2" green wire to pin 8 of the 11-pin plug (S-1). Insert the other end through the two cable clamps on the chassis base center section and leave it free.
- () Connect the free end of the brown wire coming from the cable clamps to lug 9 of the 11-pin plug (S-1).
- () Connect the free end of the white wire coming from the zener diode to pin 10 of the 11-pin plug (S-1).
- () Connect the free end of the white wire coming from lug 4 of tube socket V1 to pin 11 of the 11-pin plug (S-1).
- () Connect one end of a 9" white wire to lug 1 of the fuse holder (S-1). Place the other end through the cable clamps.
- () Connect a 1-1/2" green wire from lug 3 of the Sideband switch (S-1) to lug 1 of crystal socket CB (S-1).
- () Connect the free end of the green wire coming from lug 1 of V6 to lug 2 of the Sideband switch (S-1).
- () Connect a 3/4" #20 bare wire from lug 1 of the Sideband switch (S-1) to lug 1 of crystal socket CA (S-1).
- () Solder lug 2 of crystal socket CA (S-1) and CB (S-1) to the small #6 solder lug of each socket.
- () Install the 2998.5 kc crystal in socket CA and the 3001.5 kc crystal in socket CB.
- () Connect the 3 mc trap (#40-406) from the center lug of the antenna jack (S-1) to lug 1 on wafer C of the BAND switch (S-1).
- () Connect the free end of the brown wire coming from lug 3 of tube socket V1 to pin 2 of the 11-pin plug (S-1).
- () Connect the free end of the red wire coming from lug 1 of terminal strip N to pin 3 of the 11-pin plug (S-1).
- () Connect the free end of the green audio transformer lead to pin 4 of the 11-pin plug (S-1).
- () Connect a 2-1/2" green wire from lug 4 of the phone jack (S-1) to pin 5 of the 11-pin plug (S-1).

- () Form and then connect a 1-1/4" #16 bare wire from lug 3 of terminal strip W (S-2) to lug 1 of the 2-section variable capacitor (S-1).
- () Connect a 5-1/2" #16 bare wire from lug 1 on wafer B of the BAND switch (S-1) to lug 2 of the 2-section variable capacitor (S-1). Use sleeving.
- () Connect the free end of the #16 bare wire coming from lug 7 on wafer A of the BAND switch to lug 3 of the 2-section variable capacitor (S-1).
- () Connect a 1-3/4" #16 bare wire from lug 4 of the 2-section variable capacitor (S-1) to solder lug AK (S-1).
- () R31. Place a control solder lug on the shaft of the 1 megohm AF GAIN control (#19-42) and install this control fully in the slotted hole of the tuning mechanism. Use a control flat washer and control nut. Do not tighten. See Detail 14H. Make sure the control solder lug is in line and touching lug 1 of the control. If necessary, loosen the mounting screws of the tuning mechanism and chassis base center section to make sufficient room to mount the control. Remember to retighten the mounting screws after this adjustment.

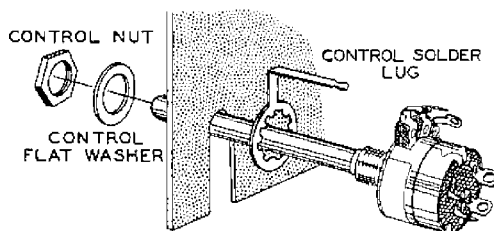

Detail 14H

- () Turn the AF GAIN control until lugs 1, 2, and 3 are up. Connect the inner conductor of the shielded wire coming from the cable clamp to lug 2 of the AFGAIN control (S-1). Connect the shield to lug 1 of this control (NS).
- () Connect a 1-1/4" #20 bare wire from lug 6 (S-1) to lug 1 (S-3) of the AF GAIN control.
- () Turn the AFGAIN control until lugs 1, 2, and 3 are down, and tighten.
- () Connect the brown wire coming from the cable clamp to lug 4 of the AF GAIN control (S-1).

NOTE: Inspect the rear of the AF GAIN control and determine if the control was manufactured by PR Mallory or CTS. Then follow the two steps under the proper heading listed below.

PR MALLORY CONTROL

- () Connect the white wire coming from the cable clamp to lug 7 of the AFGAIN control (S-1).
- () Connect the two green wires coming from the cable clamp and the brown wire from lug 5 of V4 to lug 5 of the AFGAIN control (S-3).

CTS CONTROL

- () Connect the white wire coming from the cable clamp to lug 5 of the AFGAIN control (S-1).
- () Connect the two green wires coming from the cable clamp and the brown wire from lug 5 of V4 to lug 7 of the AFGAIN control (S-3).
- () C64. Connect a .01 μ fd disc capacitor from lug 3 of terminal strip D (S-2) to lug 3 of AF GAIN control (S-1).

- () Route the two shielded cables coming from the Noise Limiter switch as shown in Pictorial 14.
- () Referring also to Detail 12A on Page 39, connect the inner conductor coming from lug 1 of the Noise Limiter switch to lug 9 of V5 (S-3). Connect, but do not solder the shield to the #20 bare wire between lug 1 of V5 and lug 3 of terminal strip E.
- () Connect the inner conductor coming from lug 2 of the Noise Limiter switch to lug 8 of V5 (S-2). Connect the shield to the same #20 bare wire used in the previous step (S-3). Make sure all three cable shields are soldered to the bare wire.
- () Start two 6-32 x 1/8" setscrews in a shaft coupling and slide it half-way on one end of the short insulated sideband selector shaft as shown. Now fit the coupling onto the Sideband switch shaft and tighten both setscrews.
- () Install the shaft adapter on capacitor AE.
- () Pass one end of the long insulated shaft through the proper holes in the tuning mechanism and oscillator shield. Start two 6-32 x 1/8" setscrews in a shaft coupling, slide it half-way on the end of the insulated shaft, and onto the shaft of variable capacitor AE; tighten both setscrews.
- () Start an 8-32 x 1/4" setscrew in the bushing of the dial drum drive pulley assembly (#100-M19). Make sure the BAND switch shaft is rotated fully counterclockwise, then place the dial drum drive pulley (flat side first) on the BAND switch shaft with the rim opening corresponding to the slotted BAND switch mounting hole. Tighten the setscrew when the flat side of the pulley is 5/8" from the main dial plate of the tuning mechanism. See Pictorial 15.

BAND SWITCH AND DIAL DRUM STRINGING

Refer to Pictorial 15 for the following steps.

- () Using the remaining length of dial cord, form a small loop on one end as shown. Carefully observe Pictorial 15 and make sure the two main pulleys are positioned as shown. Place the dial cord loop over the hook on the dial drum drive pulley. Now, following

the numbered arrows, pass the cord through the pulley rim. Then proceed to the left, straight to arrow position #3. Make 1-1/2 turns around the dial drum shaft pulley to its rim opening (arrow position #6). Now make one complete turn on the stud in the rim opening as shown; proceed to the idler pulley, and on to the rim opening of the dial drum drive pulley.

- () Temporarily place one end of the dial cord spring over the pulley hook.
- () Pass the free end of the dial cord through the other end of the spring. Pull the cord taut enough to stretch the spring about 1/4" and secure the cord to the spring with several overhand knots. Cut off and discard the balance of the cord.
- () If the low frequency scale (3.5 to 4 mc) on the dial drum (with the BAND switch in the full counterclockwise position) faces forward, no other adjustments will be necessary at this time. If however, this is not the case, it will be necessary to loosen the 6-32 setscrew in the bushing to the left of the dial drum. Rotate the dial drum until the 3.5 to 4 mc scale faces forward. Now tighten the screw.

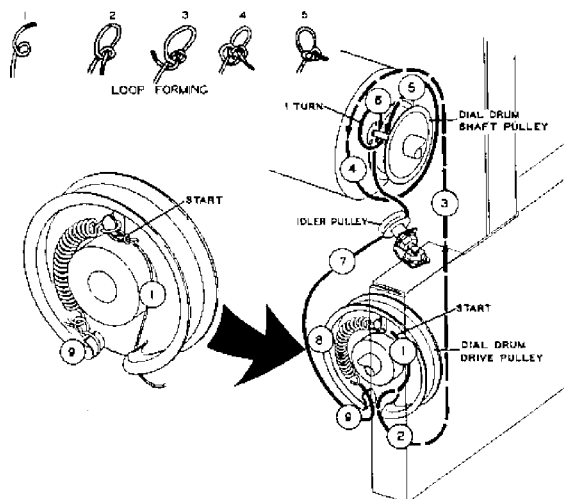

Pictorial 15

FRONT PANEL AND BRACKET MOUNTING

Refer to Pictorial 16 for the following steps.

- () Locate the dial pointer and place it on the dial pointer bracket above the dial drum as shown in Detail 16A.

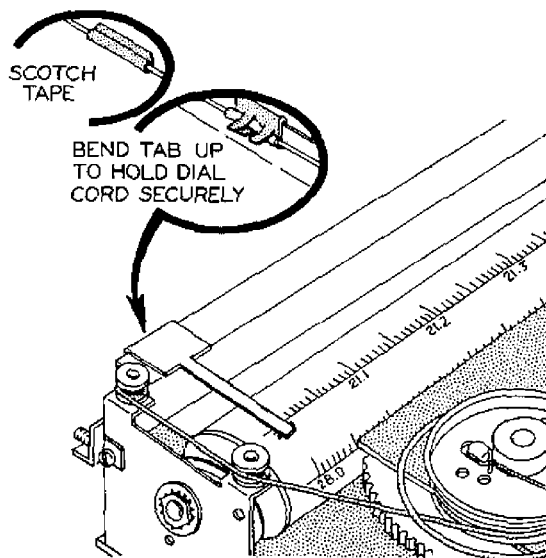

Detail 16A

- () Rotate the Main Tuning shaft fully counter-clockwise and place the dial cord between the pointer fingers as shown in Detail 16A. The cord may be protected with scotch tape if desired.
- () Position the pointer so there are equal spaces between the pointer and band edge calibration marks at both ends when in the 80-meter position. Then bend the center pointer finger up to secure it firmly to the dial cord. Use care not to cut the cord if tape is not used.
- () Locate the finished front panel (#203-168F-237-253) and, using care not to mar the painted surface, fasten the front panel mounting bracket (#204-M223) to it by inserting 1/4" x 3/8" bushings with a control flat washer from the front at holes A, C, E, and F. Secure these bushings with thin control lockwashers and control nuts.
- () Locate the AVC switch (#63-289) and place a control solder lug on the shaft. Mount this switch at hole G as shown. Secure with a control flat washer and control nut, while making sure the solder lug is in line with and touching lug 5. Bend the solder lug to make a neat fit.
- () R3. Locate the 10 K Ω RF GAIN control (#10-131) and place a control nut and control solder lug on the shaft as shown. Make sure the solder lug is in line with and touching lug 3. Bend the solder lug to make a neat fit. Mount this control at B with a control flat washer and control nut.
- () Mount the Function switch to the panel at J with 6-32 x 1/4" screws into the tapped switch mounting holes.
- () Now mount the front panel and mounting bracket assembly to the chassis base, after first sliding the shafts carefully through the bushings. Use 6-32 x 1/4" screws, #6 lockwashers and 6-32 nuts. Loosen the tuning mechanism mounting screws (also the front panel bushings if necessary) and retighten if any shaft binding is noticed when mounting this assembly.
- () Check the dial drum frequency scales at this time to make sure that each scale comes into clear view when rotating the BAND switch as observed from the front panel. If you need some dial drum adjustment, loosen the setscrew in the dial drum plug and rotate slightly, as needed to bring the scales into clear view. Retighten the setscrew.

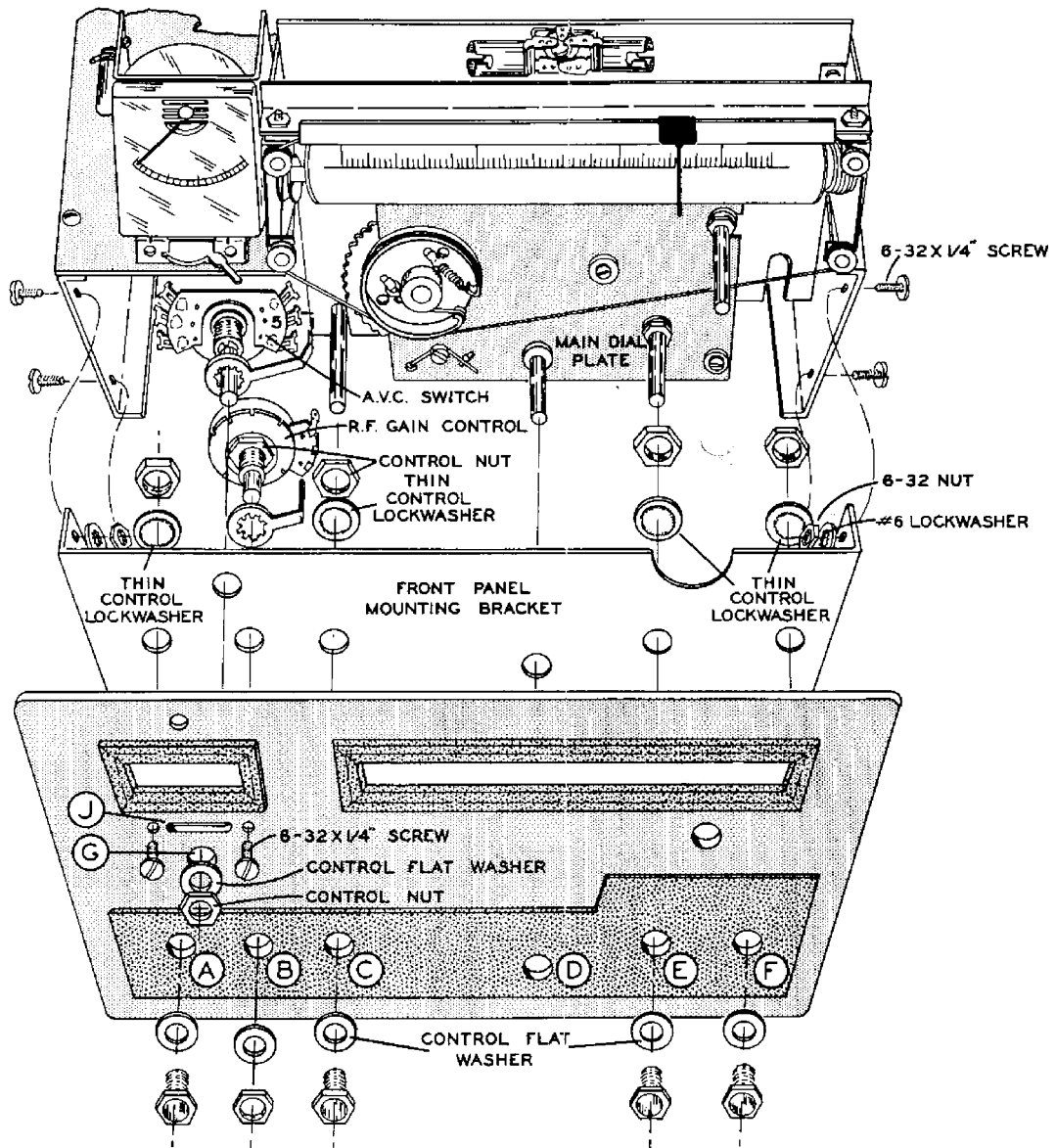

Pictorial 16

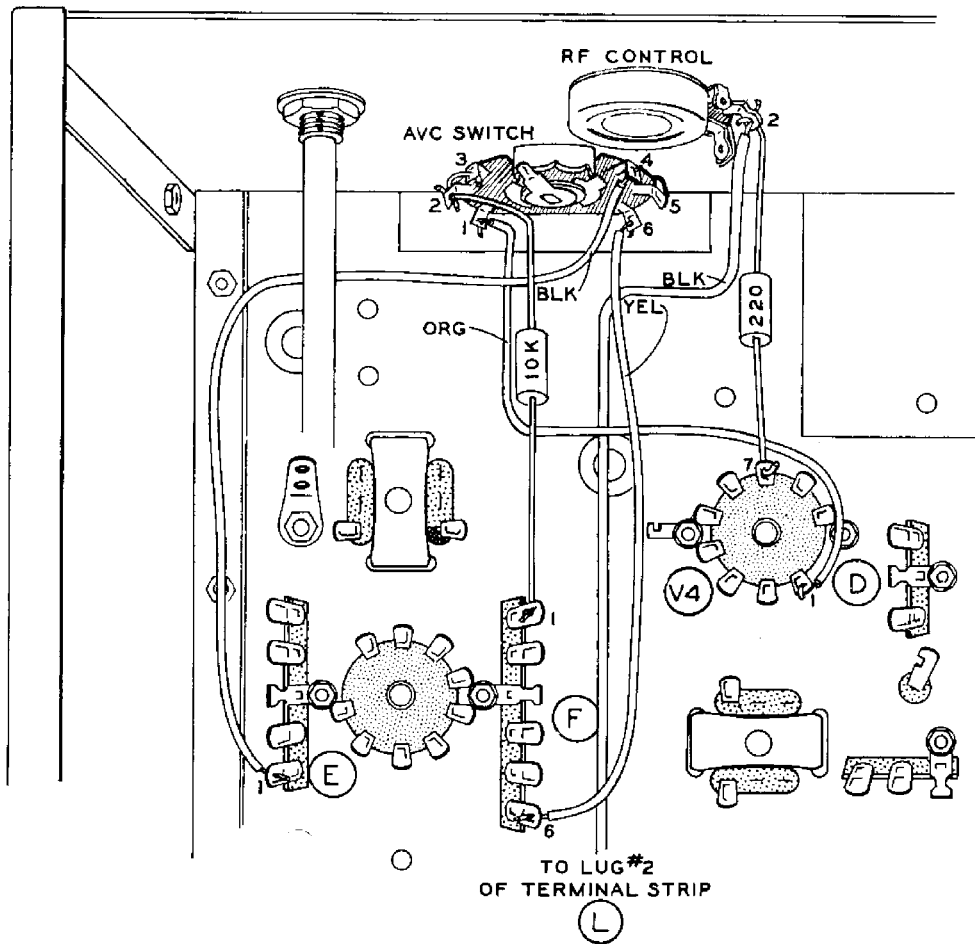

Pictorial 17

WIRING CHASSIS TOP PLATE TO FRONT PANEL

Refer to Pictorial 17 for the following steps.

- () R17. Connect a 10 KΩ (brown-black-orange) 1/2 watt resistor from lug 1 of terminal strip F (S-4) to lug 2 of the AVC switch (NS).
- () Connect a 1/2" #20 bare wire from lug 3 (S-1) to lug 2 (S-2) of the AVC switch.
- () Connect the orange wire from lug 1 of V4 to lug 1 of the AVC switch (S-1).
- () Connect the yellow wire from lug 6 of terminal strip F to lug 6 of the AVC switch (S-1).
- () Solder the control solder lug to lug 5 of the AVC switch (S-1).
- () Connect the black wire from lug 1 of terminal strip E to lug 4 of the AVC switch (S-1).
- () Connect the black wire from lug 2 of terminal strip L to lug 2 of the RF GAIN control (NS).

- () R20. Connect a 220 Ω (red-red-brown) 1/2 watt resistor from lug 2 of the RF GAIN control (S-2) to lug 7 of V4 (S-2).
- () Solder the control solder lug to lug 3 of the RF GAIN control (S-1).

"S" METER AND FUNCTION SWITCH

Refer to Detail 18A for the following steps.

- () Turn the chassis top plate assembly over.
- () Mount a large #6 solder lug at AG. Use 6-32 x 1/4" hardware.
- () Connect the orange wire coming from grommet A to lug 4 of the FUNCTION switch (S-1).
- () Connect the inner conductor of the longer shielded wire coming from grommet A to lug 3 of the FUNCTION switch (S-1). Connect the shield to solder lug AG (NS).
- () Connect the inner conductor of the shorter shielded wire coming from grommet AF to lug 1 of the FUNCTION switch (S-1). Connect the shield to solder lug AG (NS).

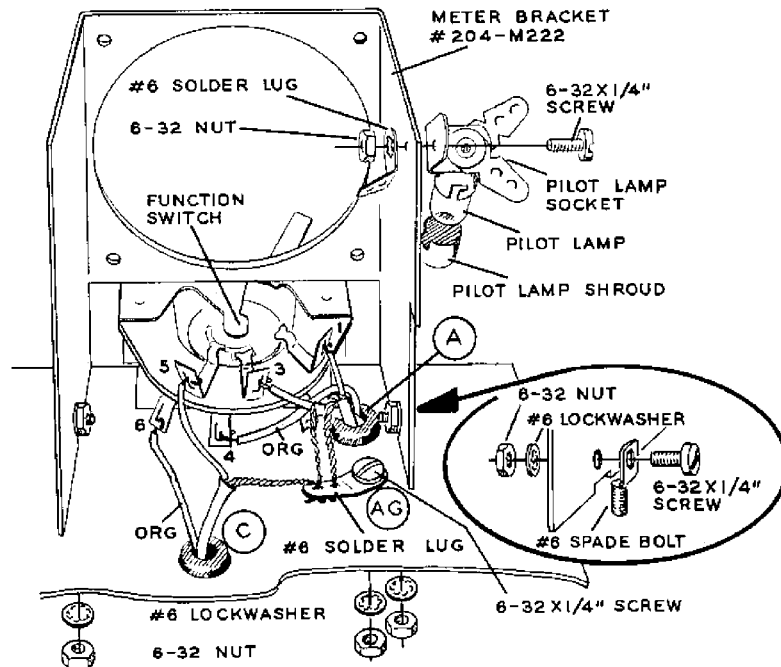

Detail 18A

- () Connect the orange wire coming from grommet C to lug 6 of the FUNCTION switch (S-1).
- () Connect the inner conductor of the shielded wire coming from grommet C to lug 5 of the FUNCTION switch (S-1). Connect the shield to solder lug AG (S-3).
- () Mount and position a pilot lamp socket and a large #6 solder lug to the meter mounting bracket, using a 6-32 x 1/4" screw and a 6-32 nut as shown. Place a #44 pilot lamp into the socket and a pilot lamp shroud over the lamp as shown.
- () Mount spade lugs on the meter mounting bracket as shown. Use #6 hardware.

Refer to Pictorial 18 for the following steps.

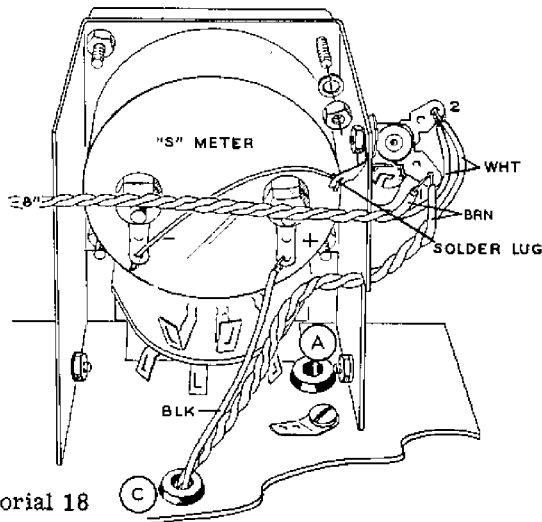

Pictorial 18

- () Remove the shorting clip on the "S" meter terminals and mount the meter to the meter mounting bracket as shown. Use the hardware supplied with the meter. The meter scale numbers should be in an upright position, and the meter adjustment screw should be at the top of the meter bracket. Do not excessively tighten the meter nuts.
- () Mount the meter bracket to the chassis top plate using #6 lockwashers and 6-32 nuts.
- () Connect the black wire coming from grommet C to the positive (+) terminal on the meter (S-1).

- () Connect a #20 bare wire from the solder lug (S-1) to the minus (-) terminal of the meter (S-1).
- () Locate the free end of the twisted pair coming from the pilot lamp sockets, and connect the brown wire to lug 1 (NS) and the white to lug 2 (NS) of the pilot lamp socket on the meter bracket.
- () Locate the free end of the twisted pair coming from grommet C and connect the brown wire to lug 1 (S-2) and the white wire to lug 2 (S-2) of the pilot lamp socket on the meter bracket.
- () Now carefully install all the tubes in their proper sockets. You will find four sizes of tube shields. The 1-3/4" tube shields should be placed over the 6BZ6 and 6BE6 tubes. The 1-7/8" tube shields should be placed over the 6EA8 and 6BJ7 tubes. The 2-1/4" and 2-3/8" tube shields should be placed over the OA2 and 6EB8 tubes, respectively.
- () Locate the 1-3/4", the 1-1/4", and the 9/16" knobs. Start an 8-32 x 1/4" setscrew in each of the 1-1/4" knobs, with two in the 1-3/4" knob. Use an 8-32 x 1/8" setscrew in each of the 9/16" knobs.
- () Rotate each of the protruding front panel shafts (except the Main Tuning shaft and ANT TUNING shaft) to their full counter-clockwise position.

Install each of the knobs on the indicated shaft and tighten the setscrew when the knob arrow corresponds to its indicated position as directed in the following steps.

<u>KNOB SIZE</u>	<u>SHAFT</u>	<u>POSITION</u>
() 9/16"	AVC OFF-FAST-SLOW	OFF
() 1-1/4"	SB1-SB2	SB1
() 1-1/4"	RF GAIN	0
() 1-1/4"	AF GAIN	OFF
() 9/16"	NOISE LIMITER	OFF
() 1-1/4"	BAND Knurled	80



- () Rotate the ANT TUNING shaft so that the capacitor plates are at full mesh. Install a 9/16" knob on the shaft and tighten the setscrew when the knob arrow is at its 9 o'clock position.
- () Place a 1-3/4" knob on the Main Tuning shaft and tighten the two setscrews.
- () Slide the plastic lever knob onto the lever of the CW-SSB-AM Function switch.

POWER CABLE PREPARATION

WARNING: THIS KIT CANNOT BE USED WITH POSITIVE GROUND ELECTRICAL SYSTEMS.

Refer to Pictorial 19 for the following steps.

- () Locate the plug cap, 11-pin socket and length of 8-conductor cable.
- () Remove a 3/4" length of outer insulation from each end of the 8-conductor cable.
- () Remove 1/4" of insulation from each end of the 8 conductors. Tin each conductor lightly to hold the strands together.

NOTE: Pictorial 19 and Detail 19A show the female 11-pin socket connections for this Receiver. If you intend to use the HEATHKIT Mobile Power Supply and the HEATHKIT Model HX-20 Mobile Transmitter with your Receiver, you will find additional octal plugs (with associated instructions for connections) in the Transmitter kit.

If you have the HX-20 Transmitter or are intending to use one, make the following connections at one end of the 8-conductor cable supplied with the transmitter to the 11-pin socket as indicated. See Pictorial 19. If however, you have or are intending to use a transmitter other than the HX-20, use the 8-conductor cable supplied with this kit. The following wiring information can be used to determine the cable connections.

WIRING HR-20 RECEIVER TO THE HX-20 TRANSMITTER FOR USE WITH A 12 VOLT DC POWER SUPPLY.

8-CONDUCTOR CABLE WIRE COLOR	CONNECT TO 11-PIN SOCKET LUG
() Green	1 (S-1)
() #20 bare bare	2 (NS) to 6 (NS)
() #20 bare bare	2 (S-2) to 10 (S-1)
() Orange	3 (S-1)
() Yellow	4 (S-1)
() Blue	5 (S-1)
() Red	6 (S-2)
() White	7 (NS)
() Black	7 (S-2)
() Brown	8 (S-1)
() #20 bare wire	9 (S-1) to 11 (S-1) Use sleeving

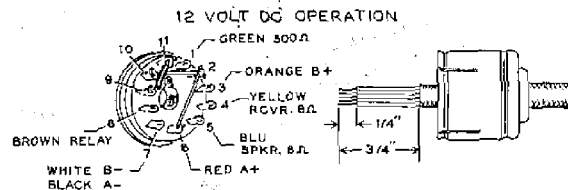

Pictorial 19

- () Place the plug cap over the socket as shown. Push firmly on the cap until it snaps into place on the socket.

WIRING HR-20 RECEIVER TO THE HX-20 TRANSMITTER FOR USE WITH A 110 VOLT AC POWER SUPPLY.

Refer to Detail 19A while connecting the 8-conductor cable to the 11-pin socket as indi-

cated in the following steps.

8-CONDUCTOR CABLE WIRE COLOR	CONNECT TO 11-PIN SOCKET LUG
------------------------------------	---------------------------------

- | | |
|--|---------------------|
| () Green | 1 (S-1) |
| () #20 bare wire | 2 (S-1) to 7 (NS) |
| () Orange | 3 (S-1) |
| () Yellow | 4 (S-1) |
| () Blue | 5 (S-1) |
| () Red | 6 (S-1) |
| () White | 7 (NS) |
| () Black | 7 (NS) |
| () Brown | 8 (S-1) |
| () 51 Ω 1 watt resistor (green-brown-black) | 7 (S-4) to 11 (S-1) |

- () Place the plug cap over the socket as shown. Push firmly on the cap until it snaps into place on the socket.

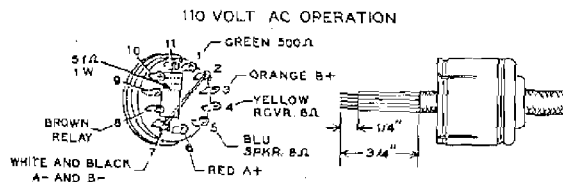

Detail 19A

WIRING HR-20 RECEIVER TO THE HX-20 TRANSMITTER FOR USE WITH A 6 VOLT DC POWER SUPPLY.

Although 6 volt operation is not recommended for the HR-20 Receiver, it can be operated from 6 volts by making the following changes in the Receiver, and by wiring the 11-pin socket as shown in Detail 19B.

Refer to Pictorials 2 and 14 for the following steps.

- () Remove the #20 bare wire from between lug 3 and the center post of tube socket V3.

- () Remove the white wire extending through grommet C from lug 4 of tube socket V4 (NS). Connect this wire to lug 5 of V4 (NS).

- () Connect a #20 bare wire from lug 4 of tube socket V4 (S-3) to the solder lug of V4 (S-4).

- () Connect a 2-1/4" brown wire from lug 5 of tube socket V4 (S-2) to lug 4 of the AF GAIN control (S-2).

Refer to Detail 19B while connecting the 8-conductor cable to the 11-pin socket as indicated in the following steps.

8-CONDUCTOR CABLE WIRE COLOR	CONNECT TO 11-PIN SOCKET LUG
------------------------------------	---------------------------------

- | | |
|-------------------|--------------------|
| () Green | 1 (S-1) |
| () #20 bare wire | 2 (S-1) to 6 (S-1) |
| () Orange | 3 (S-1) |
| () Yellow | 4 (S-1) |
| () Blue | 5 (S-1) |
| () #20 bare wire | 8 (NS) to 11 (S-1) |
| () White | 7 (NS) |
| () Black | 7 (S-2) |
| () Brown | 8 (S-2) |

- () Place the plug cap over the socket as shown. Push firmly on the cap until it snaps into place on the socket.

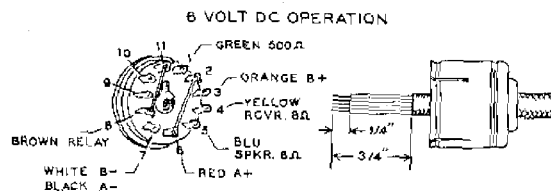

Detail 19B

CAUTION: Be sure to perform all the steps under "Wiring HR-20 Receiver To The HX-20 Transmitter For Use With A 6 Volt DC Power Supply" before operating the Receiver on 6 volts.



SPEAKER CONSIDERATIONS

The speaker plug fits the speaker jack on the rear panel of your Receiver. There is no speaker furnished with this kit, but you should use an 8 Ω speaker.

- () Any single-conductor wire with an outer shield can be used for the speaker connection. The center conductor should be fastened to the center lug of the speaker plug and the outer shield to the outer body of the speaker plug.

CAUTION: Do not operate this Receiver without a speaker being connected. Damage to the output transformer may result.

Do not remove the tubes without turning off the Receiver.

This completes the wiring and assembly of your Receiver. Carefully check all wiring for unintentional short circuits and properly soldered connections. Shake out any loose wires and other foreign objects.

INITIAL CHECK

After you have made a careful visual examination of the wiring, proceed with the following additional checks.

Using an 11 megohm input VTVM, make the following resistance checks of each pin of the power plug (P-1) with the negative lead of the VTVM connected to the chassis. Make sure the AF GAIN control is in the OFF position.

11-PIN PLUG PIN NO.	RESISTANCE
() 1	30 Ω
() 2	0
() 3	6 megohms to infinity
() 4	1 to 2 Ω
() 5	infinity
() 6	infinity
() 7	0
() 8	infinity

If these checks are reasonably close to the resistance values listed, you may assume at

this time that you have properly wired the Receiver; continue with the following steps. If, however, the values do not correspond reasonably close to any or all of the given values, then carefully recheck your wiring with the Step-By-Step Assembly instructions and correct any errors you may find.

NOTE: It is assumed in the following steps that the HEATHKIT Power Supply is being used in connection with the HR-20 Receiver and HX-20 Transmitter.

- () Connect your Receiver to the Transmitter Power connector using the prepared power cable. Connect the Transmitter to the power supply as directed in the transmitter manual.
- () Turn on the Power Supply.
- () Turn the Receiver AF GAIN control clockwise. This will apply both filament and plate voltages. If nothing happens which might indicate short circuiting of any of the components, then proceed to the following steps, covering adjustments.

Should trouble develop at this point, turn off the Receiver immediately and refer to the section titled, "In Case Of Difficulty" and the associated "Troubleshooting Chart."

ADJUSTMENTS

"S" METER SETTING

- () With all power off, set the "S" meter pointer to the 60 db position with the screwdriver adjustment on the front of the meter.
- () Turn the Power Supply on and then the Receiver. Do not connect the antenna.

- () Set the AVC switch to the FAST or SLOW position.
- () Turn the RF GAIN control fully counterclockwise.
- () If the "S" meter pointer does not rest at the "O" reading, then adjust the 25 Ω (S-METER ZERO) control on top of the chassis until a "O" reading is obtained. Check to see that both AVC positions (FAST and SLOW) provide this "O" reading.
- () Turn AVC OFF. The "S" meter pointer should return to the 60 db position. This completes the "S" meter adjustment.

IF STAGES

- () Connect an 8 Ω speaker to the Receiver.

NOTE: If using the receiver separately, jumper pins 4 and 5 of the 11-pin socket.

- () Turn on the Receiver and let it warm up for at least half an hour for stability and accuracy of settings. If you are using a mobile power supply instead of a fixed model, a charger with 10 ampere capacity should be connected to the battery to keep it from running down while making these adjustments.
- () After the Receiver has gone through the warmup period, set the Receiver front panel controls as follows:

<u>CONTROL</u>	<u>SETTING</u>
AVC	FAST
Function	AM
RF GAIN	Full clockwise
AF GAIN	2/3 clockwise
Main Tuning	To any incoming signal
ANT TUNING	To highest meter reading
NOISE LIMITER	OFF
BAND	Any position

- () Using the plastic alignment tool furnished with this kit, turn the slugs of IF transformers T1 and T2 from the top of the chassis until a maximum "S" meter reading or audible signal is obtained.

This completes the alignment of the IF stages. Alignment of the high frequency will be performed next.

RF ADJUSTMENTS

NOTE: You should have on hand at this time for the following adjustment a RF signal generator with modulation and a frequency range that covers 3 to 30 mc.

Before adjusting the high frequency oscillator as indicated in the following RF Alignment Chart, it will be necessary to make a few preliminary preparations and keep some points in mind.

First connect the RF signal generator to the Receiver ANTenna input connector. The generator output should be set so that a maximum reading of 9 units on the "S" meter is obtained when peaking a coil or trimmer capacitor. Also, peak the ANTenna TUNING capacitor for each adjustment.

When adjusting the coils and trimmers, set both the generator and the Receiver dial to the frequency indicated in the RF Alignment Chart. Adjust the trimmer capacitor for each band at the low frequency end of the dial drum, and adjust the coil at the low frequency end. It will be necessary to repeat each of these adjustments because of the coil and capacitor interaction on the same band.

The coils are preset at approximately the correct settings, so adjust the capacitors first, then proceed to the RF Alignment chart. Be sure to set the generator and Receiver dial to the same frequency and adjust the specified coil or trimmer for a peak "S" meter reading. Remember, these adjustments are quite sharp, so work slowly.



RF ALIGNMENT CHART		
BAND	GENERATOR AND RECEIVER DIAL FREQUENCY	ADJUST
10 METERS	1. 29.7 mc 2. 28 mc 3. Repeat #1 and #2 4. 28.8 mc 5. 28.8 mc	C37 L11 L11 and C37 L6* L1**
15 METERS	1. 21.5 mc 2. 21.0 mc 3. Repeat #1 and #2 4. 21.25 mc 5. 21.25 mc	C40 L12 L12 and C37 L7* L2**
20 METERS	1. 14.35 mc 2. 14.0 mc 3. Repeat #1 and #2 4. 14.17 mc 5. 14.17 mc	C43 L13 L7 and C43 L8* L3**
40 METERS	1. 7.3 mc 2. 7.0 mc 3. Repeat #1 and #2 4. 7.15 mc 5. 7.15 mc	C46 L14 L14 and C46 L9* L4**
80 METERS	1. 4.0 mc 2. 3.5 mc 3. Repeat #1 and #2 4. 3.75 mc 5. 3.5 mc	C49 L15 L15 and C49 L10* L5**

* Use the peak "S" meter reading at which the coil slug is at minimum penetration in the coil form.

** Set the ANTenna TUNING capacitor at half mesh.

CABINET INSTALLATION

Refer to Pictorial 20 for the following steps.

- () Locate the cabinet (#90-100) and note that there are four screw holes in the bottom to which rubber feet may be attached. If the Receiver is to be used for fixed station application, mount the feet as follows. No feet will be used for mobile installations.
- () Mount the two small rubber feet at the bottom rear of the cabinet, using 6-32 x 3/8" screws, #6 lockwashers, and 6-32 nuts as shown.

- () Mount the two large rubber feet at the bottom front of the cabinet, using 6-32 x 1" screws, #6 lockwashers and 6-32 nuts as shown.

NOTE: The pilot lamp shrouds may be positioned at this time so as to avoid glare under night-driving conditions.

- () Now slide the Receiver into the front of the cabinet, using care not to mar the front panel.

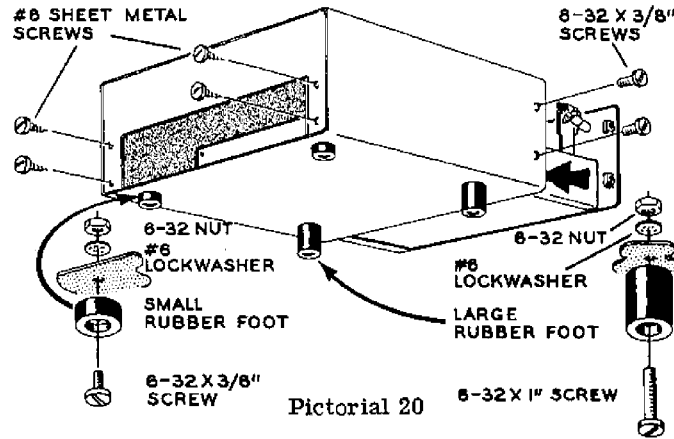

Pictorial 20

- () Fasten the cabinet to the chassis rear apron using four #6 sheet metal screws as shown.
 - () Fasten the front panel to the cabinet sides using four 8-32 x 3/8" screws as shown.
- You are now ready to install the Receiver.

INSTALLATION

MOBILE INSTALLATIONS

As stated before, this Receiver was designed primarily for use as a companion to the HEATHKIT Model HX-20 Transmitter and the HEATHKIT Mobile Power Supply. Other units may be used with this Receiver, provided the proper connections and voltages are supplied as stated in the Specifications.

Pictorial 21 shows how the HR-20 Receiver and HX-20 Transmitter cabinets may be bolted together and mounted under the dash, using the HEATHKIT Mobile Mounting Bracket. For additional convenience, the HEATHKIT Mobile Speaker may be used in your installation. This method of installation is offered only as a suggestion, realizing that mounting requirements may vary considerably. Pictorial 22 shows the

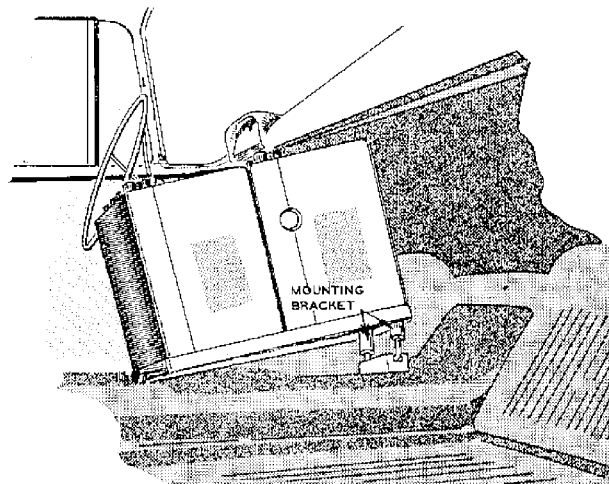
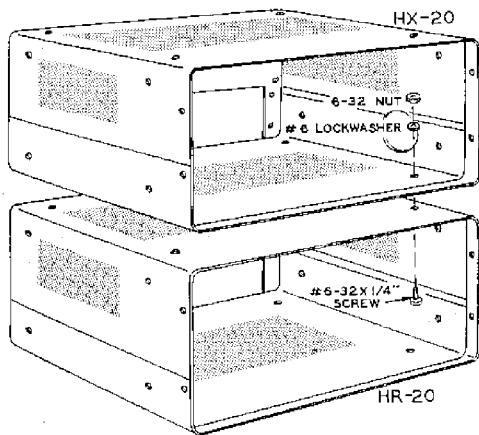

Pictorial 21

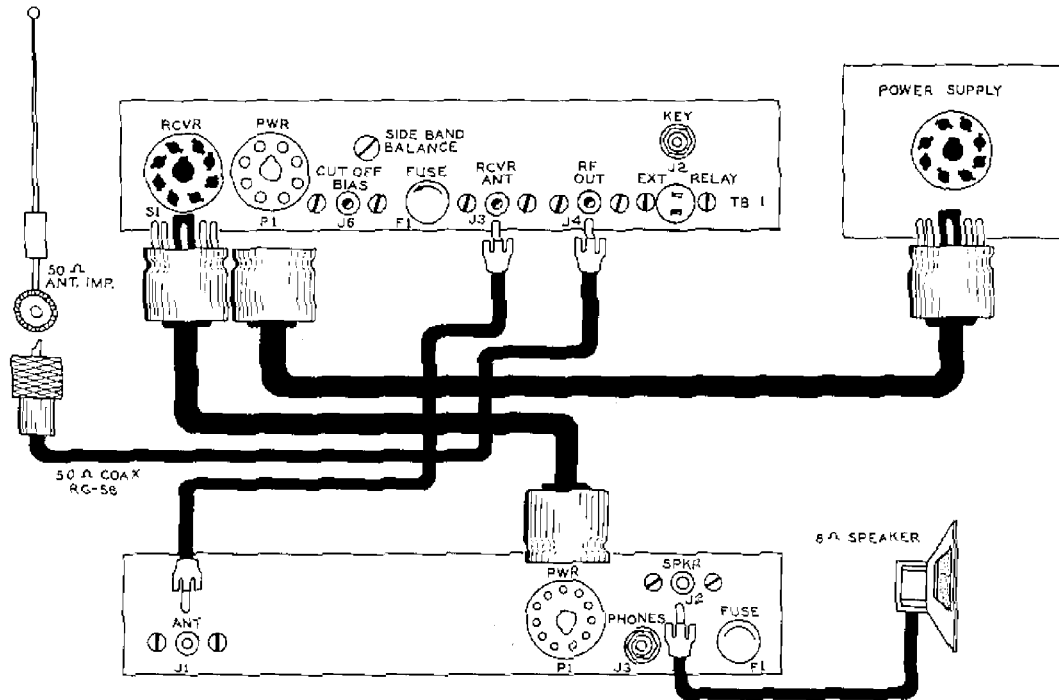

Pictorial 22

proper mobile electrical connections between the HEATHKIT units.

FIXED INSTALLATIONS

The HR-20 Receiver and HX-20 Transmitter

serve very nicely as fixed station units also, along with the HEATHKIT AC Power Supply. Also, the HEATHKIT Linear Amplifier may be used if high power is desired. Pictorial 23 shows the proper connections between these units in a fixed installation.

NOISE SUPPRESSION

If fixed station, rather than mobile operation is intended, skip this section and refer forward to the Operation section on Page 58.

Since the Receiver has an excellent noise limiter incorporated in its design, most electrical interference will be limited. However, the noise limiter should not be given too much work to do, as at high engine speeds a noisy ignition system, generator "whine," and voltage regulator "hash" will tend to mask weak signals, although with the limiter working, the interference may appear to be completely eliminated.

Another reason for good electrical interference suppression at the source is that strong electrical pulses contain enough energy when integrated to block the AVC circuit of the Receiver, causing the gain to drop whenever the engine is speeded up. In addition, the IF amplifier of the Receiver will also tend to lengthen the duration of the noise pulses because the relatively high-Q IF tuned circuits will ring or oscillate when excited by a sharp pulse, such as produced by ignition noise.

Determining the source of various types of

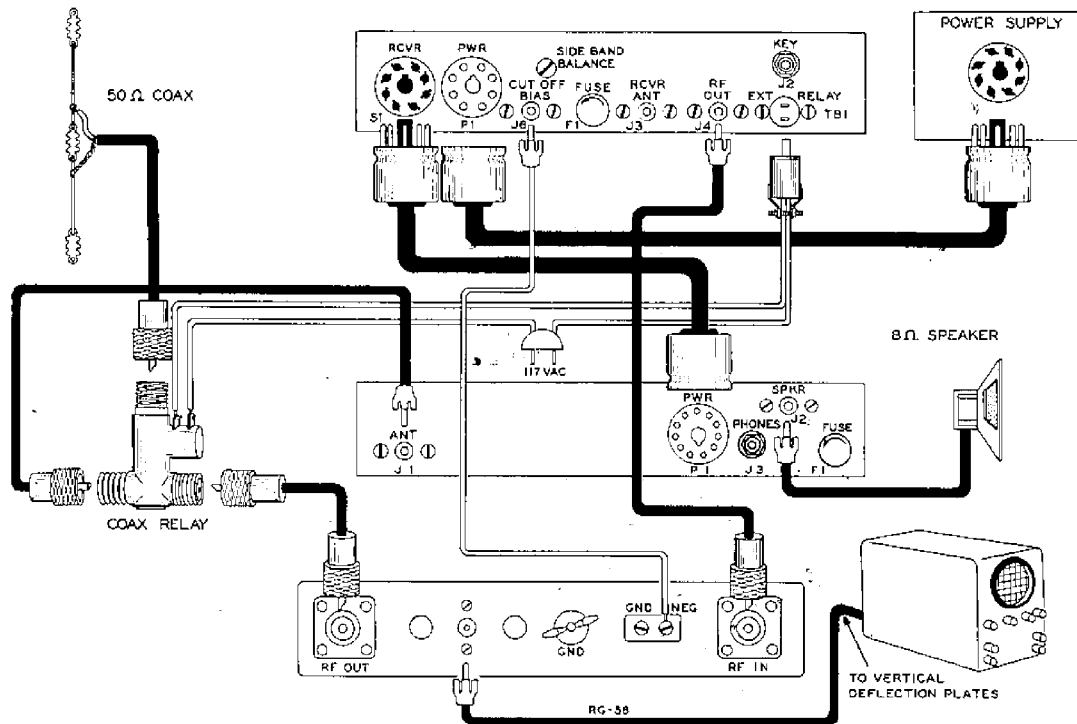

Pictorial 23

noise can be difficult, particularly when several items are contributing to the noise. To isolate and identify the various items that may be producing the major noise interference, follow the procedure outlined below.

In some cases one source of interference will mask all others, consequently it will be necessary to suppress the questionable item and then continue with the other steps. Pictorial 24 shows a typical ignition system and the suggested placement of noise suppression components.

1. Locate the vehicle in an area that is free from other man-made electrical interference such as power lines, manufacturing processes, and particularly other automobiles.
2. With the Receiver on and the NL switch off, run the automobile at medium speed. Then let up on the gas, turn the ignition

switch off and to the accessory position. Allow the vehicle to coast in gear. If all noise stops, the major source of interference is from the ignition system.

3. If the noise interference continues from step 2, but at a reduced level, both the ignition and generator systems are at fault.
4. If the noise has "whine" characteristics and changes in pitch when varying engine speed and is still present with the ignition off, then the generator is the major source of interference.
5. A distinct but irregular clicking noise, or "hash" as it is sometimes called, that disappears with the ignition off, indicates the voltage regulator is at fault.
6. A steady popping noise that continues with the ignition off indicates wheel or tire static



CAUTION
 THE VOLTAGE REGULATOR SHOWN IS ONLY REPRESENTATIVE. BATTERY, ARMATURE AND FIELD CONNECTIONS MAY NOT BE IN ORDER INDICATED. DO NOT BYPASS FIELD WINDING WITHOUT A RESISTOR IN SERIES. CHECK TERMINAL LOCATION CAREFULLY.

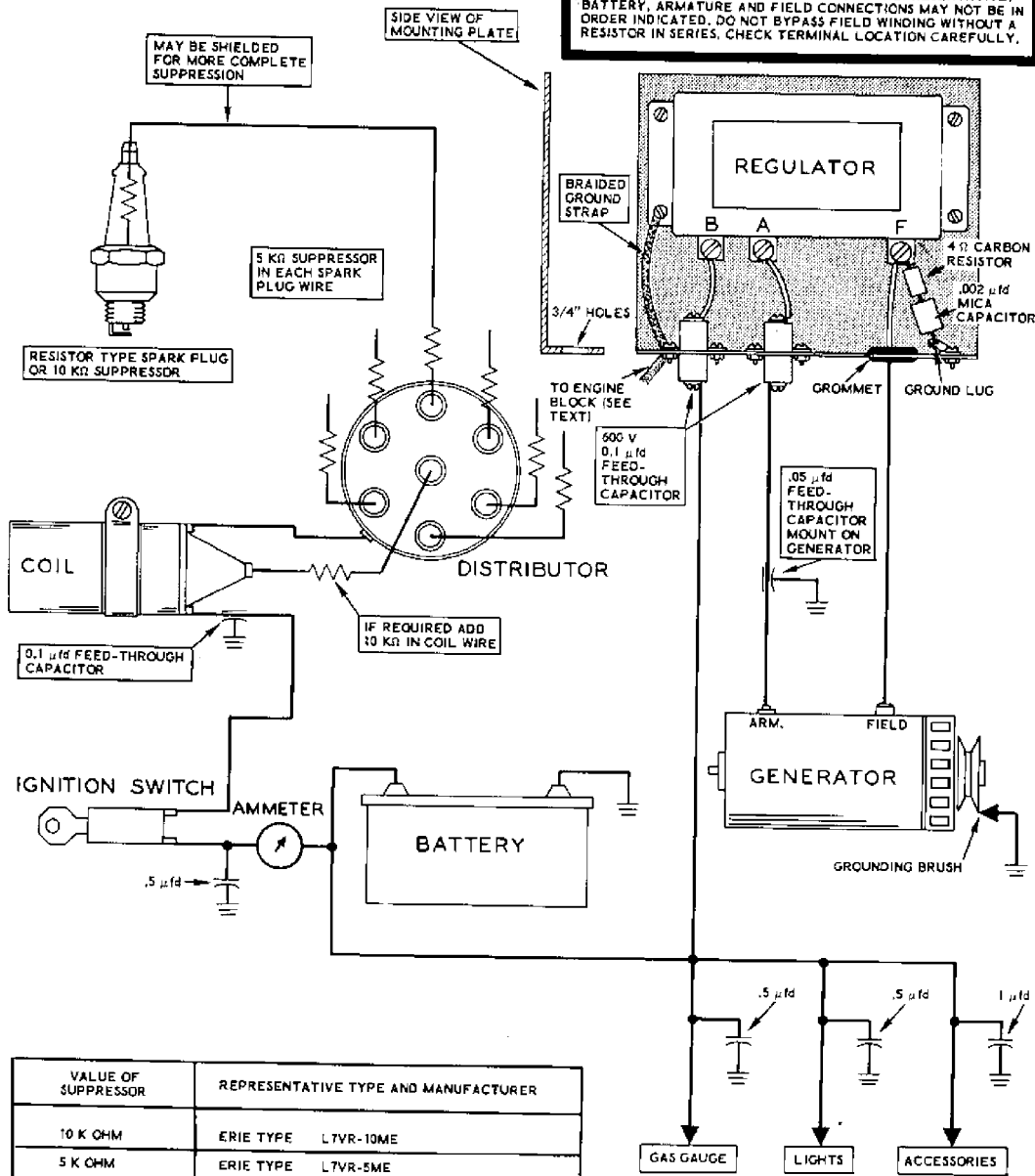

VALUE OF SUPPRESSOR	REPRESENTATIVE TYPE AND MANUFACTURER
10 K OHM	ERIE TYPE L7VR-10ME
5 K OHM	ERIE TYPE L7VR-5ME
0.5 MFD FEED-THROUGH	SPRAGUE 48P16 (40 AMP)
0.1 MFD FEED-THROUGH	SPRAGUE 80P3
.5 MFD	MALLORY AG-451
1 MFD	MALLORY AG-452

NOTE ALL GROUND CONNECTIONS SHOULD BE MADE TO THE COMPONENT BEING BYPASSED, PREFERABLY MOUNTED DIRECTLY ON IT.

Pictorial 24

interference. This is more pronounced on smooth roads.

7. The same type of interference as in step 6, but more irregular when on bumpy roads, particularly at slow speeds, indicates body static.

Referring to the Troubleshooting Chart and to Pictorial 24 will help in determining how to suppress most of the noise interference en-

countered. Naturally, not all vehicles will require suppression to the extent shown in Pictorial 24, but some stubborn cases may require all the suppression components as shown, plus shielding of the ignition system.

Bonding together of various parts of the automobile, starting from the hood and continuing to the trunk, even including bonding of the transmission line every few feet from the antenna cannot be overemphasized.

NOISE TROUBLESHOOTING CHART		
TYPE OF NOISE	PROBABLE CAUSE	RECOMMENDED REMEDY
Loud popping increasing to buzz with increased engine speed.	Ignition system.	<ol style="list-style-type: none"> 1. Replace plugs with resistor type. (Most recommended.) 2. Loose crimped connections should be cleaned and soldered. 3. Place resistors in distributor system.
Whine - varies with engine speed.	Generator.	<ol style="list-style-type: none"> 1. 0.5 μfd coaxial type capacitor in series with the armature (A lead). 2. Clean commutator. 3. Replace brushes. 4. Ground generator shaft. 5. Parallel trap (#10 wire-coil and suitable capacitor) in series with armature lead, tuned to operating frequency.
Distinct but irregular clicking noise.	Voltage regulator.	<ol style="list-style-type: none"> 1. 0.1 μfd coaxial type capacitor in series with the battery (B) and armature (A) leads. 2. A series combination of a .002 μfd mica capacitor and a 4 Ω carbon resistor to ground from the field (F) terminal. All components should be mounted as shown in diagram, close to voltage regulator.
Same as above.	Energy transfer to primary system.	<ol style="list-style-type: none"> 1. Bypass at the following points: coaxial bypass in lead to coil from ignition switch at the coil (0.1 μfd). Battery lead to ammeter (.5 μfd); to gas gauge (0.5 μfd); to oil signal switch (0.5 μfd); head and tail light leads (.5 μfd); accessory wiring from engine compartment (.5 μfd).
Loud popping noise that changes from one type road to another. Most pronounced on concrete.	Wheel static.	Installation of front wheel static collectors (available from most automotive distributors). These should be checked every 5000 miles for excessive wear.
Same as above.	Tire static.	Injection of anti-static powder into tire through valve stem.



TYPE OF NOISE	POSSIBLE CAUSE	RECOMMENDED REMEDY
Irregular popping noise when on bumpy roads, particularly at slow speeds.	Body static.	Tighten all loose screws. Use heavy flexible braid and bond the engine to the frame and fire wall. Bond the controls rods, speedometer cable, exhaust pipes, etc., to the frame.
It is recommended that if an extensive amount of suppression was required, the engine should be retimed and tuned up at a reputable garage.		

OPERATION

CONTROLS

AF GAIN: Advancing this control from the full counterclockwise position turns the power on. Further control advancement increases the audio output to the speaker.

STANDBY-RECEIVE: In normal operation, when this Receiver is used with the HX-20 Transmitter, simply pressing the microphone button or using VOX operation actuates a relay located in the transmitter, which removes B+ from the Receiver but allows the filament voltage to remain constant. Since there is no standby receiver switch on the front of the Receiver, it may be well for the kit builder to provide an external B+ switching arrangement in fixed station applications without the accompanying HX-20 Transmitter.

RF GAIN: This control provides a means of varying the gain of the RF and IF stages. In general, especially on AM signals, it should be left in the maximum position, except when very strong signals are received.

SELECTIVITY: Good bandwidth is provided on AM and single sideband. However, when working with CW the selectivity may be made much sharper by setting the Main Tuning slightly to either side of the signal, depending on the QRM encountered.

BAND SWITCH: This switch selects the proper oscillator, mixer, and antenna coil-capacitor combinations for the particular frequency band in use.

ANT TUNING: This capacitor tunes the input to the RF amplifier and should be adjusted for each band used. On some bands, particularly 80, 15 and 10 meters, it may be necessary to adjust this capacitor when working the extreme ends of the bands, due to the relatively wide coverage in frequency.

NOISE LIMITER: This switch allows attenuation of excessive ignition or line noise in the AM position. Due to the clipping action of the noise limiter, the tops of strong signal waveforms may be flattened, resulting in distortion. In such cases, it is suggested that the RF GAIN be reduced to bring in signals below the preset clipping point.

AVC SELECT: This switch allows the Receiver to operate with automatic control of the RF and IF gain without sacrificing sensitivity. In the OFF position, the audio output will vary according to variations in input signal strength. With FAST or SLOW AVC, the audio output will automatically be kept relatively constant with varying input signal conditions. It is recommended, however, when using AVC, that the AVC SELECT switch be placed in the FAST position for AM signals and in the SLOW position for CW and SSB operation. Since the "S" meter is actuated by amplified AVC voltage, it will only operate with AVC applied.

CW/SSB-AM: This switch selects the type of detection to be used: Product detector for CW/SSB, diode detector for AM.



TUNING AM SIGNALS

Set the CW/SSB-AM switch in the AM position, the RF GAIN control fully clockwise, the AVC SELECT switch in the FAST position, and the AF GAIN control to the desired audio volume. Select the band desired with the BAND switch, adjusting the ANTenna TUNING capacitor for maximum signal, or maximum background noise in the event that no signal is present.

When tuning a station, tune for maximum "S" meter reading. If the signal is covered up with QRM, it is still possible to read the station by varying the main tuning to the right or left of center frequency, although the best quality will prevail with the maximum "S" meter reading.

TUNING SSB SIGNALS

Again the Receiver is set for the band desired and the CW/SSB-AM switch is set in the CW/SSB position. AVC may be either OFF or in the SLOW position, adjust the ANTenna

TUNING control for maximum signal or background noise.

Two important points in tuning SSB are:

First, determine which sideband is being transmitted and then set the SIDEBAND SELECT switch in the proper position, SB1 or SB2. It should be noted here that most SSB stations use the lower sideband on 80 and 40 meters and the upper sideband on 20, 15, and 10 meters.

Secondly, tune slowly. The Receiver must be tuned to the sideband station's frequency within a few cycles or distortion will result.

TUNING CW SIGNALS

The Receiver is again set up the same as for SSB operation and may be used with the AVC, OFF or in the SLOW position. Normally, it will be found more suitable to advance the AF GAIN control to a higher level and reduce the RF GAIN control when receiving CW.

IN CASE OF DIFFICULTY

1. Recheck the wiring. Trace each lead in colored pencil on the Pictorial as it is checked. It is frequently helpful to have a friend check your work. Someone who is not familiar with the unit may notice something consistently overlooked by the constructor.
2. It is interesting to note that about 90% of the kits that are returned for repair, do not function properly due to poor connections and soldering. Therefore, many troubles can be eliminated by reheating all connections to make sure that they are soldered as described in the Proper Soldering Techniques section of this manual.
3. Check to be sure that all tubes are in their proper locations. Make sure that all tubes light up properly.
4. Check the tubes with a tube tester or by substitution of tubes of the same types and known to be good.
5. Check the values of the parts. Be sure that the proper part has been wired into the circuit, as shown in the pictorial diagrams and as called out in the wiring instructions.
6. Check for bits of solder, wire ends or other foreign matter which may be lodged in the wiring.
7. If, after careful checks, the trouble is still not located and a voltmeter is available, check voltage readings against those shown on the Schematic Diagram. NOTE: All voltage readings were taken with an 11 megohm input vacuum tube voltmeter. Voltages may vary as much as 10%.
8. A review of the Circuit Description will prove helpful in indicating where to look for trouble.



TROUBLESHOOTING CHART		
TROUBLE	POSSIBLE CAUSE	CORRECTION
Filaments and/or pilot lamps fail to light.	<ol style="list-style-type: none"> Lack of filament voltage. Error in filament wiring. Terminal strip T wired wrong. Switch on AF GAIN control open. Blown fuse. 	<p>Check pin 6 of the power socket (P-1) to the chassis to determine if filament voltage is present. Recheck filament wiring. Recheck wiring of terminal strip T.</p> <p>Replace control.</p> <p>Replace fuse after correcting the cause.</p>
Some filaments and/or pilot lamps operate, some do not.	<ol style="list-style-type: none"> Error in filament wiring. Short to ground of half of the filament line. 	<p>Recheck wiring, including connections to terminal strip T.</p> <p>Check the white and brown filament wires for continuity. Remove tube and pilot lamps when checking.</p>
Receiver dead, pilot lamps and filaments lit.	<ol style="list-style-type: none"> No B+ for plate power. Shorts between socket terminals, leads and components. High frequency oscillator failure. Extreme misalignment 	<p>Check pin 3 of the power socket (P-1) to determine if B+ is available.</p> <p>Relocate to remove short for proper operation.</p> <p>Check wiring, resistances, and voltages per Schematic Diagram of the mixer stage.</p> <p>Repeat alignment procedure.</p>
Hum.	<ol style="list-style-type: none"> Open grid circuit. Heater to cathode leakage in a tube. 	<p>Recheck grid wiring.</p> <p>Replace tube.</p>
Improper reception.	<ol style="list-style-type: none"> Misalignment. 	<p>Realign.</p>
Noise but no reception.	<ol style="list-style-type: none"> No antenna. BAND switch improperly wired. 	<p>Check connections.</p> <p>Check all BAND switch wiring. Remove B+.</p>

TROUBLE	POSSIBLE CAUSE	CORRECTION
"S" Meter does not center to the left indication mark after Receiver is on and warmed up.	<ol style="list-style-type: none"> 1. Meter control miswired or not adjusted. 2. Low B+ voltage. 3. High B+ voltage. 4. Wrong value of resistance in plate circuit. 5. Open meter wires. 	<p>Check wiring. Adjust meter control until needle is on "0" S units.</p> <p>Increase to proper range of 350 volts.</p> <p>Decrease to 350 V.</p> <p>Check plate resistor of "S" meter amplifier stage.</p> <p>Check wires for continuity.</p>
"S" Meter does not swing to indicate signal strength.	<ol style="list-style-type: none"> 1. Meter control miswired or not adjusted. 2. No AVC voltage. 3. Defective tube. 	<p>Check wiring. Adjust meter control with no signal to "0" left.</p> <p>Check AVC circuit wiring.</p> <p>Check V5.</p>
BFO and Product Detector inoperative.	<ol style="list-style-type: none"> 1. Bad tube. 2. No B+ voltage. 3. Error in wiring Function switch. 	<p>Replace V6.</p> <p>Check wiring from voltage regulator, V8.</p> <p>Recheck wiring of Function switch.</p>
No sound, other functions normal.	<ol style="list-style-type: none"> 1. Error in wiring first audio and power amplifier. 2. Error in wiring audio output transformer. 3. Speaker voice coil open. 	<p>Check wiring from V5 through to V7. Check voltages in these stages.</p> <p>Check transformer wiring.</p> <p>Replace.</p>
Operates AM but not CW-SSB.	<ol style="list-style-type: none"> 1. BFO failure. 	<p>Check wiring, crystals, resistance and voltages per Schematic Diagram of V6 product detector.</p>

SERVICE INFORMATION

SERVICE

If, after applying the information in this manual and your best efforts, you are still unable to obtain proper performance, it is suggested that you take advantage of the technical facilities which the Heath Company makes available to its customers.

The Technical Consultation Department is maintained for your benefit. This service is available to you at no charge. Its primary purpose is to provide assistance for those who encounter difficulty in the construction, operation or maintenance of HEATHKIT equipment. It is not intended, and is not equipped to function as a general source of technical information involving



kit modifications nor anything other than the normal and specified performance of HEATHKIT equipment.

Although the Technical Consultants are familiar with all details of this kit, the effectiveness of their advice will depend entirely upon the amount and the accuracy of the information furnished by you. In a sense, YOU MUST QUALIFY for GOOD technical advice by helping the consultants to help you. Please use this outline:

1. Before writing, fully investigate each of the hints and suggestions listed in this manual under In Case Of Difficulty. Possibly it will not be necessary to write.
2. When writing, clearly describe the nature of the trouble and mention all associated equipment. Specifically report operating procedures, switch positions, connections to other units, and anything else that might help to isolate the cause of trouble.
3. Report fully on the results obtained when testing the unit initially and when following the suggestions under In Case Of Difficulty. Be as specific as possible and include voltage readings if test equipment is available.
4. Identify the kit model number and date of purchase, if available. Also mention the date of the kit assembly manual. (Date at bottom of Page 1.)
5. Print or type your name and address, preferably in two places on the letter.

With the preceding information, the consultant will know exactly what kit you have, what you would like it to do for you and the difficulty you wish to correct. The date of purchase tells him whether or not engineering changes have been made since it was shipped to you. He will know what you have done in an effort to locate the cause of trouble and, thereby, avoid repetitious suggestions. In short, he will devote full time to the problem at hand, and through his familiarity with the kit, plus your accurate report, he will be able to give you a complete and helpful answer. If replacement parts are required, they will be shipped to you, subject to the terms of the Warranty.

The Factory Service facilities are also available to you, in case you are not familiar enough with electronics to provide our consultants with sufficient information on which to base a diagnosis of your difficulty, or in the event that you prefer to have the difficulty corrected in this manner. You may return the completed equipment to the Heath Company for inspection and necessary repairs and adjustments. You will be charged a minimal service fee, plus the price of any additional parts or material required. However, if the completed kit is returned within the Warranty period, parts charges will be governed by the terms of the Warranty. State the date of purchase, if possible.

Local Service by Authorized HEATHKIT Service Centers is also available in some areas and often will be your fastest, most efficient method of obtaining service for your HEATHKIT equipment. Although charges for local service are generally somewhat higher than for factory service, the amount of increase is usually offset by the transportation charge you would pay if you elected to return your kit to the Heath Company.

HEATHKIT Service Centers will honor the regular 90 day HEATHKIT Parts Warranty on all kits, whether purchased through a dealer or directly from Heath Company; however, it will be necessary that you verify the purchase date of your kit.

Under the conditions specified in the Warranty, replacement parts are supplied without charge; however, if the Service Center assists you in locating a defective part (or parts) in your kit, or installs a replacement part for you, you may be charged for this service.

HEATHKIT equipment purchased locally and returned to Heath Company for service must be accompanied by your copy of the dated sales receipt from your authorized HEATHKIT dealer in order to be eligible for parts replacement under the terms of the Warranty.

THIS SERVICE POLICY APPLIES ONLY TO COMPLETED EQUIPMENT CONSTRUCTED IN ACCORDANCE WITH THE INSTRUCTIONS AS STATED IN THE MANUAL. Equipment that has been modified in design will not be accepted

for repair. If there is evidence of acid core solder or paste fluxes, the equipment will be returned NOT repaired.

For information regarding modification of HEATHKIT equipment for special applications, it is suggested that you refer to any one or more of the many publications that are available on all phases of electronics. They can be obtained at or through your local library, as well as at most electronic equipment stores. Although the Heath Company sincerely welcomes all comments and suggestions, it would be impossible to design, test, evaluate and assume responsibility for proposed circuit changes for special purposes. Therefore, such modifications must be made at the discretion of the kit builder, using information available from sources other than the Heath Company.

REPLACEMENTS

Material supplied with HEATHKIT products has been carefully selected to meet design requirements and ordinarily will fulfill its function without difficulty. Occasionally, improper operation can be traced to a faulty component. Should inspection reveal the necessity for replacement, write to the Heath Company and supply all of the following information.

- A. Thoroughly identify the part in question by using the part number and description found in the manual Parts List.
- B. Identify the type and model number of kit in which it is used.
- C. Mention date of purchase.
- D. Describe the nature of defect or reason for requesting replacement.

The Heath Company will promptly supply the necessary replacement, PLEASE DO NOT RETURN THE ORIGINAL COMPONENT UNTIL SPECIFICALLY REQUESTED TO DO SO. Do not dismantle the component in question as this will void the guarantee. This replacement policy does not cover the free replacement of parts that may have been broken or damaged through carelessness on the part of the kit builder.

SHIPPING INSTRUCTIONS

In the event that your instrument must be returned for service, these instructions should be carefully followed.

Wrap the equipment in heavy paper, exercising care to prevent damage. Place the wrapped equipment in a stout carton of such size that at least three inches of shredded paper, excelsior, or other resilient packing material can be placed between all sides of the wrapped equipment and the carton. Close and seal the carton with gummed paper tape, or alternately, tie securely with stout cord. Clearly print the address on the carton as follows:

To: HEATH COMPANY
Benton Harbor, Michigan

ATTACH A LETTER TO THE OUTSIDE OF THE CARTON BEARING YOUR NAME, COMPLETE ADDRESS, DATE OF PURCHASE, AND A BRIEF DESCRIPTION OF THE DIFFICULTY ENCOUNTERED. Also, include your name and return address on the outside of the carton. Preferably affix one or more "Fragile" or "Handle With Care" labels to the carton, or otherwise so mark with a crayon of bright color. Ship by parcel post or prepaid express; note that a carrier cannot be held responsible for damage in transit if, in HIS OPINION, the article is inadequately packed for shipment.



WARRANTY

Heath Company warrants that for a period of three months from the date of shipment, all Heathkit parts shall be free of defects in materials and workmanship under normal use and service and that in fulfillment of any breach of such warranty, Heath Company shall replace such defective parts upon the return of the same to its factory. The foregoing warranty shall apply only to the original buyer, and is and shall be in lieu of all other warranties, whether express or implied and of all other obligations or liabilities on the part of Heath Company and in no event shall Heath Company be liable for any anticipated profits, consequential damages, loss of time or other losses incurred by the buyer in connection with the purchase, assembly or operation of Heathkits or components thereof. No replacement shall be made of parts damaged by the buyer in the course of handling or assembling Heathkit equipment.

NOTE: The foregoing warranty is completely void and we will not replace, repair or service instruments or parts thereof in which acid core solder or paste fluxes have been used.

HEATH COMPANY

TYPICAL COMPONENT TYPES

This chart is a guide to commonly used types of electronic components. The symbols and related illustrations

should prove helpful in identifying most parts and reading the schematic diagrams.

<p style="text-align: center;">RESISTOR</p>	<p style="text-align: center;">CAPACITOR</p>	<p style="text-align: center;">TUBE</p>
<p style="text-align: center;">POTENTIOMETER (CONTROL)</p>	<p style="text-align: center;">ELECTROLYTIC CAPACITOR</p>	<p style="text-align: center;">PNP TRANSISTOR</p> <p style="text-align: center;">NPN TRANSISTOR</p>
<p style="text-align: center;">TRANSFORMER (IRON CORE)</p>	<p style="text-align: center;">VARIABLE CAPACITOR</p>	<p style="text-align: center;">RECTIFIER (DIODE)</p>
<p style="text-align: center;">TRANSFORMER (ADJUSTABLE POWDERED IRON CORE)</p> <p style="text-align: center;">INDICATES DIRECTION OF CORE MOVEMENT TO INCREASE INDUCTANCE</p>	<p style="text-align: center;">BATTERY</p>	<p style="text-align: center;">NEON BULB</p>
<p style="text-align: center;">TRANSFORMER (ADJUSTABLE CORE)</p>	<p style="text-align: center;">PHONO JACK</p>	<p style="text-align: center;">ILLUMINATING BULB</p>
<p style="text-align: center;">POWER TRANSFORMER</p>	<p style="text-align: center;">PHONE JACK</p>	<p style="text-align: center;">METER</p>
<p style="text-align: center;">INDUCTOR (COIL)</p>	<p style="text-align: center;">RECEPTACLE</p>	<p style="text-align: center;">SPST SWITCH (TOGGLE)</p> <p style="text-align: center;">DPDT</p>
<p style="text-align: center;">PIEZOELECTRIC CRYSTAL</p>	<p style="text-align: center;">SPEAKER</p>	<p style="text-align: center;">SWITCH (ROTARY)</p>
<p style="text-align: center;">BINDING POST</p>	<p style="text-align: center;">MICROPHONE</p>	<p style="text-align: center;">FUSE</p>
<p style="text-align: center;">ANTENNA</p>	<p style="text-align: center;">EARTH GROUND</p> <p style="text-align: center;">CHASSIS GROUND</p>	<p style="text-align: center;">CONDUCTORS</p>