

Assembly and Operation
of the



2-METER TRANSCEIVER
MODEL HW-17A



HEATH COMPANY
BENTON HARBOR, MICHIGAN 49022

TABLE OF CONTENTS

INTRODUCTION	5
The Transceiver.	6
The Manual.	7
TRANSCEIVER PACKAGING.	7
CIRCUIT BOARD ASSEMBLY	
Transmitter Circuit Board Parts List.	8
Step-By-Step Assembly.	10
Receiver Circuit Board Parts List.	14
Step-By-Step Assembly.	16
CHASSIS ASSEMBLY	
Chassis Parts List.	23
Step-By-Step Assembly.	26
Parts Assembly.	26
Chassis Wiring.	40
Front Panel, Tube, And Crystal Installation.	56
Microphone Wiring.	58
Line Cord Wiring.	60
INITIAL TESTS.	63
ALIGNMENT	
Transmitter Alignment.	66
Receiver Alignment.	73
Tuner Alignment.	76
FINAL ASSEMBLY.	77
INSTALLATION	
Fixed Station.	79
Mobile Station.	81

OPERATION	
Function Of Operating Controls.	85
Receiving.	85
Transmitting.	86
Factory Repair Service.	88
IN CASE OF DIFFICULTY	
General Tests.	89
Transmitter Troubleshooting Chart.	90
Receiver Troubleshooting Chart.	92
Audio Troubleshooting Chart.	94
SPECIFICATIONS	
Transmitter.	96
Receiver.	97
General.	98
CIRCUIT DESCRIPTION.	
Transmitter Circuits.	100
Receiver Circuits.	104
Transmit-Receive Audio Circuits.	108
Metering Circuits.	111
T-R Switching.	112
Power Supply.	112
VOLTAGE CHART.(fold-out from page).	113
RESISTANCE CHART.(fold-out from page).	114
CHASSIS PHOTOGRAPHS.	114
CIRCUIT BOARD X-RAY VIEWS.	116
REPLACEMENT PARTS PRICE LIST.	119
SCHEMATIC (fold-out from page).	119

INTRODUCTION

THE TRANSCEIVER

The Heathkit Model HW-17A 2-meter Transceiver uses a transistorized dual-conversion circuit and a prebuilt, prealigned, FET (field effect transistor) tuner to receive amplitude modulated radio signals between 143.2 MHz and 148.2 MHz. It will transmit within the same frequency range on any one of four switch-selected crystal frequencies. It may also be used with the Heathkit Model HG-10 series VFO, for which input and power connectors are provided. One transmitter crystal is furnished with the Transceiver; this crystal provides an output at 145.08 MHz. Three other crystal sockets are provided for the crystals of your choice.

The frequency range of the transceiver includes the amateur 2-meter band (144-148 MHz), the Civil Air Patrol frequencies at 143.9 and 148.15 MHz, together with the MARS and U.S. Coast Guard auxiliary frequencies.

The Transceiver may be installed as either a fixed or a mobile station (on negative ground automobiles), and its gimbal mounting bracket permits quick interchange between the two types of operation. Fixed stations use the built-in AC power supply, which may be wired for either 120 or 240 volts. For mobile use, the 12 volt Heathkit Model HWA-17-1 Solid-State Power Supply is available as an accessory. It simply plugs into a connector on the rear apron of the Transceiver. A "Battery Saver" switch on the front panel activates the receiver portion only, which draws only 100 mA of current (the pilot light and the transmitter section are turned off).

The microphone level is fixed, which provides protection against over-modulation by limiting voice input to a predetermined level. A squelch circuit is included to eliminate noise output from the built-in speaker when no signals are present. An ANL (automatic noise limiter) circuit helps you to receive weak signals in the presence of impulse type noise.

Other features include: the Spot position on the Function switch, which enables you to easily locate your own transmitting frequency; the Phones jack, which automatically mutes the speaker when a headphones plug is inserted; the PTT (push-to-talk) microphone which is included in the kit, together with the microphone retaining clip that is mounted on the side of the cabinet; and the no-relay design, where all switching is done quickly and quietly by solid-state circuits as soon as the microphone button is pressed.

The transmitter portion is very simple to tune, but it has enough tuning controls to secure maximum efficiency from the power input. All that is necessary is to adjust the Driver Tune, Final Tune, and Final Load controls for appropriate panel meter readings. The output circuitry is designed for an antenna impedance of 52 to 72 ohms.

The exterior of the Transceiver has an attractive two-tone green wrinkle finish which matches the latest Heath designs. This exceptional Transceiver is sure to give you a great deal of satisfaction and long, dependable service.

CIRCUIT BOARD ASSEMBLY

This section of the Manual contains the Parts List and Step-By-Step Assembly instructions for each of the two circuit boards to be assembled.

To order replacement parts, refer to the Replacement Parts Price List and use the Parts Order Form furnished with this kit.

TRANSMITTER CIRCUIT BOARD PARTS LIST

This Parts List contains all of the parts used in the assembly of the transmitter circuit board. It also contains all of the solder, wire, cable and sleeving used in the kit, the instruction manual and some other forms. Save any parts and materials remaining for use later. Except for the initial parts check, do not open small

envelopes with part numbers on them until the parts are called for in the assembly steps.

Open package #1 and check each part against the following Parts List. The numbers in parentheses in the Parts List are keyed to the numbers on the Parts Pictorial.

PART No.	PARTS Per Kit	DESCRIPTION
----------	---------------	-------------

RESISTORS

1/2 Watt		
(1) 1-2	1	68 Ω (blue-gray-black)
1-66	2	150 Ω (brown-green-brown)
1-6	1	470 Ω (yellow-violet-brown)
1-9	1	1000 Ω (brown-black-red)
1-14	1	3300 Ω (orange-orange-red)
1-60	1	68 k Ω (blue-gray-orange)
1-26	2	100 k Ω (brown-black-yellow)
1-34	1	680 k Ω (blue-gray-yellow)
1-35	1	1 M Ω (brown-black-green)
1 Watt		
(2) 1-25-1	1	6800 Ω (blue-gray-red)
2 Watt		
(3) 1-20-2	1	100 Ω (brown-black-brown)
1-22-2	1	12 k Ω (brown-red-orange)
1-4-2	1	15 k Ω (brown-green-orange)

PART No.	PARTS Per Kit	DESCRIPTION
----------	---------------	-------------

CAPACITORS

Mica (resin-dipped)		
(4) 20-118	1	15 pF
20-77	1	24 pF
20-96	1	36 pF
Disc Ceramic		
(5) 21-33	1	3.3 pF
21-78	1	5 pF
21-60	1	18 pF
21-75	1	100 pF
21-17	1	270 pF
21-56	1	470 pF
21-14	12	.001 μ F
21-27	4	.005 μ F

PART No.	PARTS Per Kit	DESCRIPTION
----------	---------------	-------------

PARTS PICTORIAL

COILS AND CHOKES

(6)40-670	1	Driver grid coil (green)
40-833	1	Oscillator coil (brown)
40-929	1	Tripler plate coil (red)
(7)40-743	2	Trap coil (clear)
(8)45-37	3	18 μ H RF choke



WIRE-CABLE-SLEEVING

89-4	1	Line cord
343-7	1	Coaxial cable
344-15	1	Stranded black hookup wire
344-31	1	Stranded brown hookup wire
344-50	1	Black hookup wire
344-51	1	Brown hookup wire
344-52	1	Red hookup wire
344-53	1	Orange hookup wire
344-54	1	Yellow hookup wire
344-55	1	Green hookup wire
344-56	1	Blue hookup wire
344-57	1	Violet hookup wire
344-58	1	Gray hookup wire
344-59	1	White hookup wire
346-1	1	Black sleeving
346-2	1	Clear sleeving
347-3	1	2-conductor shielded cable

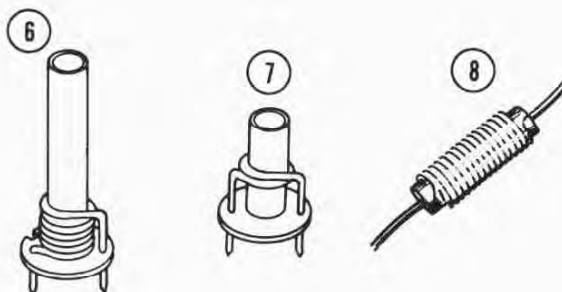

MISCELLANEOUS

(9)56-52	2	Silicon diode
85-206-3	1	Transmitter circuit board
(10)206-244	2	Coil shield
391-34	1	Heath identification label
(11)434-130	2	9-pin socket
434-140	1	12-pin socket
(12)490-1	1	Alignment tool
	1	Manual (see front cover for part number)
597-260	1	Parts Order Form
597-308	1	Kit Builders Guide
597-367	1	Registration card
		Solder

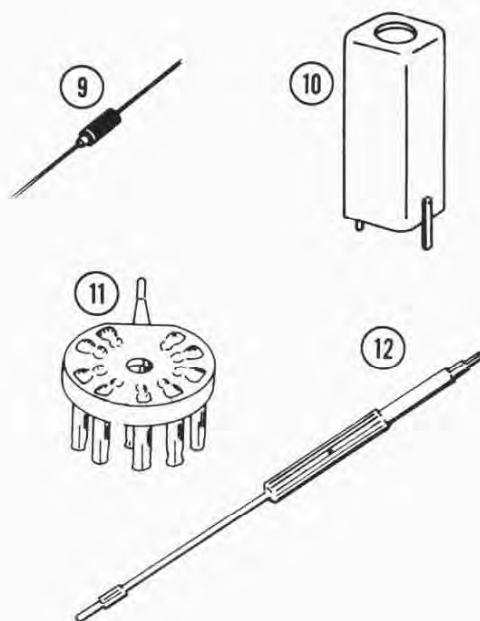

STEP-BY-STEP ASSEMBLY

Before starting to assemble this kit, read the Kit Builders Guide for complete information on wiring, soldering, and step-by-step assembly procedures.

Position all parts as shown in the Pictorials. Follow the instructions carefully, and read the entire step before performing the operation. Note that resistors are mounted vertically in some steps.

Solder a part or group of parts only when instructed. Use 1/2 watt resistors unless directed otherwise in a step. All resistors will be called out by the resistance value (in Ω , k Ω , or M Ω) and color code. Capacitors will be called out by the capacitance value and type.

On a circuit board part outline, a circle within a square represents a round coil and a square coil shield. These two parts will be mounted in separate steps.

Be especially careful not to cover unused holes, or to bridge solder between foils during the assembly of the circuit boards.

When a circuit board is finished, set it aside until it is called for later in the assembly instructions.

- () Position the transmitter circuit board (#85-206-3) lettered side up so that the outlines of the parts appear as they are shown in Pictorial 1-1. Then complete each step shown in Pictorial 1-1, 1-2, 1-3, and 1-4.

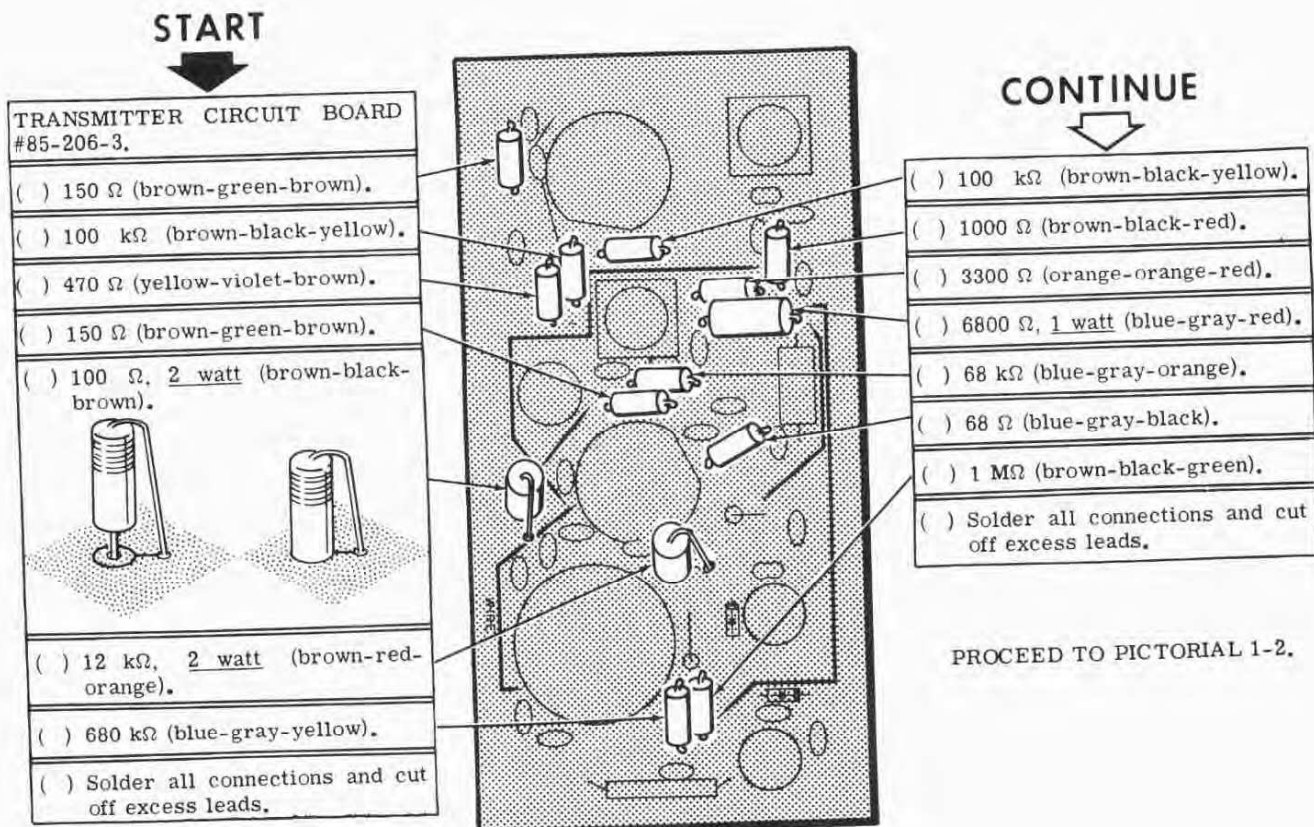

PICTORIAL 1-1

START



Transmitter Circuit Board-Continued.

NOTE: Remove any excess body coating material from disc capacitor leads before you install the capacitor.



- () .005 μ F disc.
- () 100 pF disc. Before installing the capacitor, add 1/2" of black sleeving to the lead indicated and 1/4" of sleeving to the other lead.
- () .001 μ F disc.
- () 36 pF mica.
- () 3.3 pF disc.
- () .001 μ F disc.
- () Solder all connections and cut off excess leads.
- () .001 μ F disc.
- () 470 pF disc.
- () 5 pF disc.
- () 270 pF disc.
- () .001 μ F disc.
- () .001 μ F disc.
- () .001 μ F disc.
- () Solder all connections and cut off excess leads.

1/2" SLEEVING

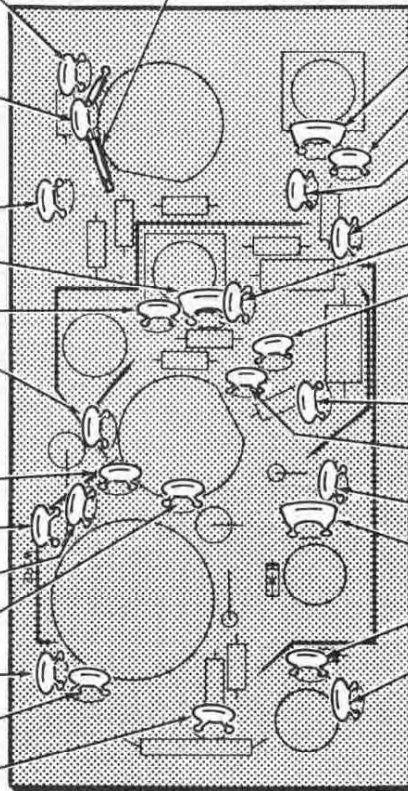

CONTINUE



- () 24 pF mica.
- () .005 μ F disc.
- () .005 μ F disc.
- () .005 μ F disc.
- () .001 μ F disc.
- () .001 μ F disc.
- () Solder all connections and cut off excess leads.
- () .001 μ F disc.
- () .001 μ F disc.
- () .001 μ F disc.
- () 18 pF disc.
- () 15 pF mica.
- () .001 μ F disc.
- () Solder all connections and cut off excess leads.

PROCEED TO PICTORIAL 1-3.

START

Transmitter Circuit Board-Continued.

- () Solder the center pin to the ground clip on the 9-pin tube sockets before mounting them on the circuit boards. Heat the center pin and allow the solder to flow onto the ground strap.

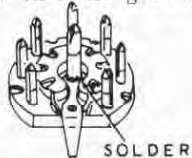

NOTE: Solder the connections of each part as it is installed. Do not cut off any socket pins after soldering.

When soldering sockets, use only enough solder to insure a good electrical contact. Do not attempt to fill each pin with solder.

- () Install 9-pin tube sockets at V1 and V2.

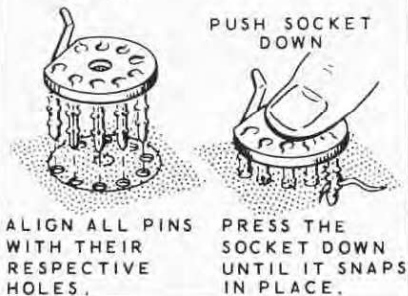

- () Remove the pin marked #6 on the 12-pin tube socket.

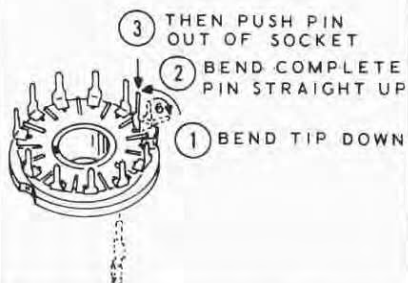

- () Install a 12-pin tube socket at V3. Before soldering, be sure the keyway is in the position shown.

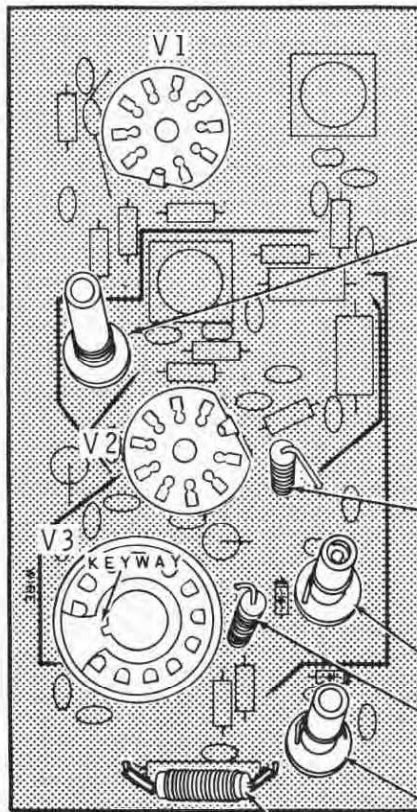

CONTINUE

- () Driver grid coil (green).

- () RF choke (#45-37). Bend one lead toward the slot, install the choke in a vertical position.

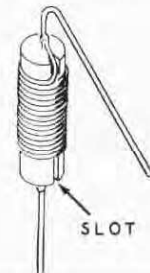

- () Trap coil (clear).

- () RF choke (#45-37).

- () Trap coil (clear).

- () RF choke (#45-37). Put 1/2" of black sleeving on each lead.

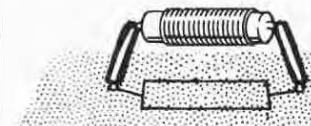

- () Cut off excess RFC leads, and check to see that all parts are soldered.

PROCEED TO PICTORIAL 1-4.

CONTINUE



START



Transmitter Circuit Board - Continued.

NOTE: To prepare a length of hookup wire, cut it to the designated length, and remove 1/4" of insulation from each end.

Prepare the following lengths of hookup wire. Form and install them at the locations shown. Solder both ends of each wire as it is installed.

- () 4-1/4" brown, X to X.
- () 1" yellow, Z to Z.
- () 2-1/8" red, U to U.
- () 4-1/2" red, T to T.
- () 2-1/4" brown, Y to Y.

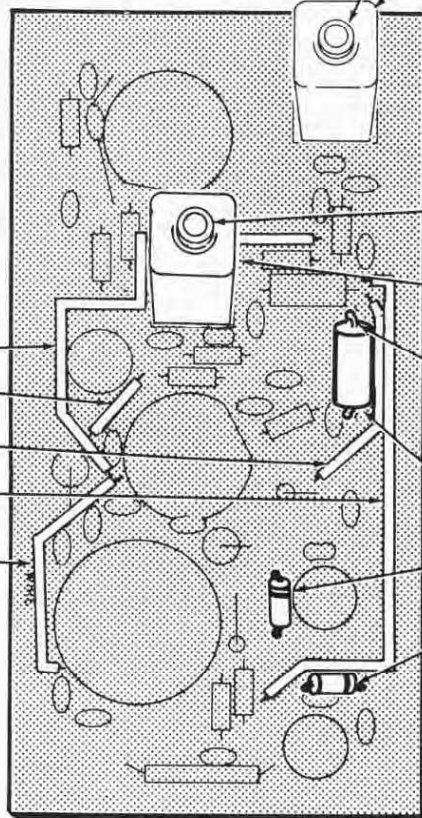

NOTE: Solder the mounting pins of each coil and coil shield as they are installed. Do not trim off the lugs of any of these parts. The orientation of coil leads is unimportant.

- () Oscillator coil (brown).
- () Coil shield. Before installing, remove and discard the liner. Be sure the end of the coil form enters the round hole in the end of the shield.



- () Tripler plate coil (red).
- () Coil shield. Before installing, remove and discard the liner.

CAUTION: DO NOT solder or trim THIS lead of the resistor installed in the next step. It will be connected later.

- () 15 kΩ, 2 watt (brown-green-orange).
- () Silicon diode #56-52, Note position of banded end.
- () Silicon diode #56-52, Note position of banded end.
- () Except the one noted, solder each connection and cut off the excess leads.

Lay this circuit board aside.

FINISH

PICTORIAL 1-4

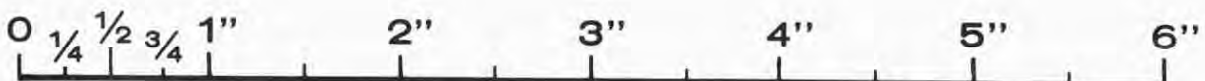

RECEIVER CIRCUIT BOARD PARTS LIST

This Parts List contains only those parts used in the assembly of the receiver circuit board. The Parts Pictorial does not contain parts previously illustrated.

Open package #2 and check each part against the following Parts List. The numbers in parentheses correspond to the numbers in the Parts Pictorial.

PART No.	PARTS Per Kit	DESCRIPTION	PART No.	PARTS Per Kit	DESCRIPTION
RESISTORS			Electrolytic		
1/2 Watt			(1)25-123	2	2 μ F
1-1	1	47 Ω (yellow-violet-black)	(2)25-54	4	10 μ F
1-2	1	68 Ω (blue-gray-black)	(3)25-115	4	10 μ F
1-3	2	100 Ω (brown-black-brown)	25-116	1	50 μ F
1-66	1	150 Ω (brown-green-brown)	25-160	1	250 μ F
1-45	1	220 Ω (red-red-brown)	25-148	2	1000 μ F
1-42	1	270 Ω (red-violet-brown)	DIODES		
1-48	1	390 Ω (orange-white-brown)	(4)56-27	2	Silicon (S-160)
1-6	2	470 Ω (yellow-violet-brown)	56-28	1	Silicon
1-7	1	680 Ω (blue-gray-brown)	(5)56-52	1	Silicon
1-8	1	820 Ω (gray-red-brown)	(6)56-67	1	Zener
1-9	3	1000 Ω (brown-black-red)	TRANSISTORS		
1-44	1	2200 Ω (red-red-red)	(7)417-91	3	2N3391
1-13	1	2700 Ω (red-violet-red)	417-118	1	2N3393
1-14	3	3300 Ω (orange-orange-red)	417-201	1	X29A829
1-16	1	4700 Ω (yellow-violet-red)	(8)417-152	1	2N1274
1-18	1	5600 Ω (green-blue-red)	(9)417-171	4	2N3694
1-19	1	6800 Ω (blue-gray-red)	COILS AND TRANSFORMERS		
1-20	3	10 k Ω (brown-black-orange)	(10)40-678	1	Mixer coil
1-21	2	15 k Ω (brown-green-orange)	(11)40-681	1	Oscillator coil
1-22	5	22 k Ω (red-red-orange)	(12)52-116	2	IF transformer
1-24	1	33 k Ω (orange-orange-orange)	(13)52-117	1	IF transformer
1-25	4	47 k Ω (yellow-violet-orange)	MISCELLANEOUS		
1-60	2	68 k Ω (blue-gray-orange)	(14)11-58	1	30 Ω control
1-31	1	330 k Ω (orange-orange-yellow)	85-205-3	1	Receiver circuit board
CAPACITORS			206-244	2	Coil shield
Mica (resin-dipped)			(15)215-8	1	Heat sink
20-52	1	7.5 pF	(16)404-67	1	26,965 MHz crystal
20-118	1	15 pF	(17)490-5	1	Nut starter
20-101	1	47 pF			
20-110	1	75 pF			
Disc					
21-75	1	100 pF			
21-26	1	.003 μ F			
21-27	3	.005 μ F			
21-16	1	.01 μ F			
21-31	3	.02 μ F			
21-48	8	.05 μ F			

PARTS PICTORIAL

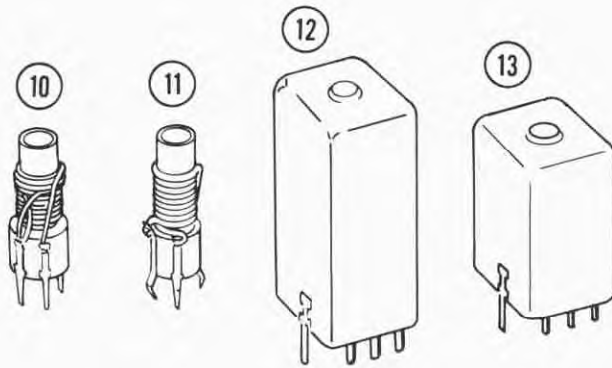
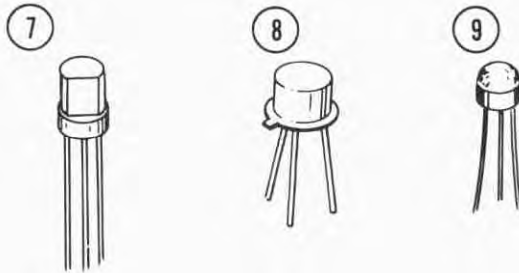
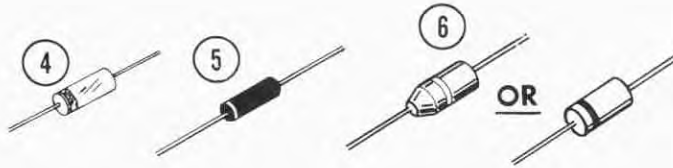
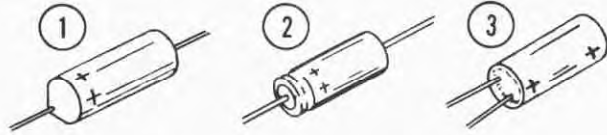

STEP-BY-STEP ASSEMBLY

Due to the size of the circuit board, only one half of it will be shown in each Pictorial. The 2200 Ω (red-red-red) resistor and one of the 22 k Ω (red-red-orange) resistors should now be laid aside for use later. These resistors will be used in the alignment of the Transceiver, after which they will be installed on the circuit board.

() Position the receiver circuit board (#85-205-3) lettered side up so that the outlines of the parts appear as shown in the Pictorial. Then complete each step in Pictorials 2-1 through 2-6.

The steps performed in this Pictorial are in this area of the circuit board.

PART NUMBER

START

CONTINUE

Receiver Circuit Board #85-205-3.
() Silicon diode (S-160) (#56-27). Note position of banded end.
() 270 Ω (red-violet-brown).
() 4700 Ω (yellow-violet-red).
() 22 k Ω (red-red-orange).
() 1000 Ω (brown-black-red).
() 15 k Ω (brown-green-orange).
() 390 Ω (orange-white-brown).
() Solder all connections and cut off excess leads.
() 10 k Ω (brown-black-orange).
() 6800 Ω (blue-gray-red).
() 1000 Ω (brown-black-red).
() 1000 Ω (brown-black-red).
() 680 Ω (blue-gray-brown).
() 3300 Ω (orange-orange-red).
() Solder all connections and cut off excess leads.

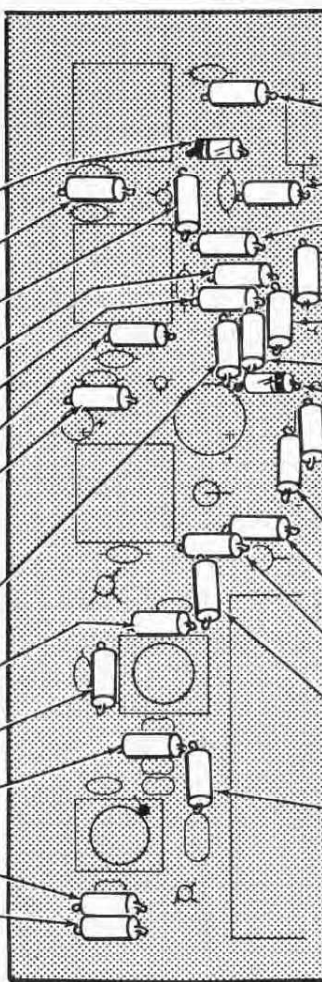

() 100 Ω (brown-black-brown).
() 68 k Ω (blue-gray-orange).
() 22 k Ω (red-red-orange).
() 68 k Ω (blue-gray-orange).
() 330 k Ω (orange-orange-yellow).
() 47 k Ω (yellow-violet-orange).
() Silicon diode (#56-28). Note position of banded end.
() Solder all connections and cut off excess leads.
() 10 k Ω (brown-black-orange).
() 47 k Ω (yellow-violet-orange).
() 68 Ω (blue-gray-black).
() 220 Ω (red-red-brown).
() 22 k Ω (red-red-orange).
() 33 k Ω (orange-orange-orange).
() Solder all connections and cut off excess leads.

PROCEED TO PICTORIAL 2-2

PICTORIAL 2-1

The steps performed in this Pictorial are in this area of the circuit board.



START



CONTINUE



- Receiver Circuit Board-Continued.
- () 1" bare wire (remove insulation from black hookup wire).
 - () 15 k Ω (brown-green-orange).
 - () 2700 Ω (red-violet-red).
 - () 5600 Ω (green-blue-red).
 - () 3300 Ω (orange-orange-red).
 - () Solder all connections and cut off excess leads.
 - () 10 k Ω (brown-black-orange).
 - () 470 Ω (yellow-violet-brown).
 - () 22 k Ω (red-red-orange).
 - NOTE: This resistor will be mounted later.
 - () 470 Ω (yellow-violet-brown).
 - () Solder all connections and cut off excess leads.

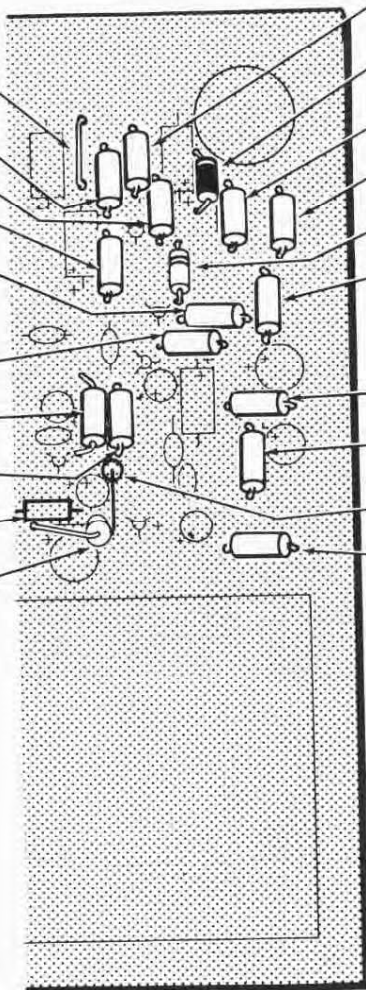

- () 3300 Ω (orange-orange-red).
- () Silicon diode (#56-52). Note position of banded end.
- () 100 Ω (brown-black-brown).
- () 820 Ω (gray-red-brown).
- () Silicon diode (S-160) (#56-27). Note position of banded end.
- () 47 Ω (yellow-violet-black).
- () Solder all connections and cut off excess leads.
- () 47 k Ω (yellow-violet-orange).
- () 150 Ω (brown-green-brown).
- NOTE: This resistor will be mounted later.
- () 47 k Ω (yellow-violet-orange).
- () Solder all connections and cut off excess leads.

PROCEED TO PICTORIAL 2-3.

PICTORIAL 2-2

The steps performed in this Pictorial are in this area of the circuit board.

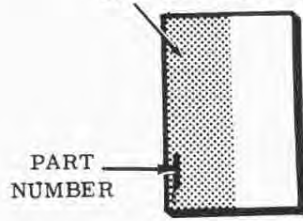

START

- Receiver Circuit Board-Continued.
- () .05 μ F disc.
 - () .05 μ F disc.
 - () .05 μ F disc.
 - () .05 μ F disc.
 - () .05 μ F disc.
 - () Solder all connections and cut off excess leads.
 - () .05 μ F disc.
 - () .003 μ F disc.
 - () .005 μ F disc.
 - () 15 pF mica.
 - () Solder all connections and cut off excess leads.

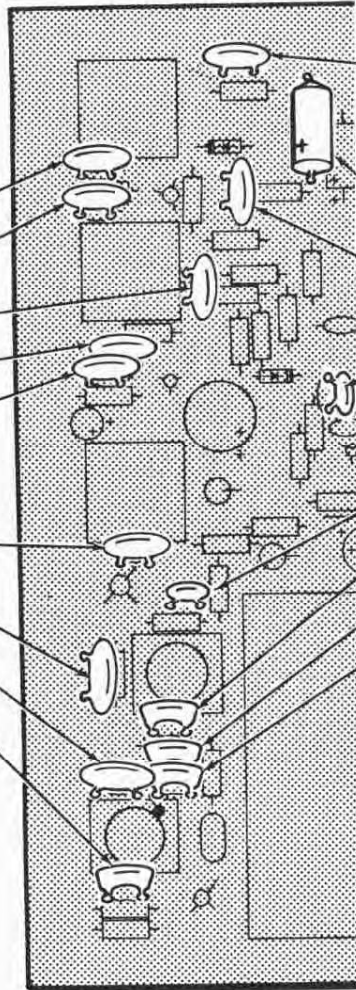

CONTINUE

- () .05 μ F disc.
- NOTE: When installing electrolytic capacitors, position the positive (+) lead at the plus (+) mark on the circuit board.
- () 2 μ F electrolytic.
- () .05 μ F disc.
- () 100 pF disc.
- () Solder all connections and cut off excess leads.
- () .005 μ F disc.
- () 47 pF mica.
- () 7.5 pF mica.
- () 75 pF mica.
- () Solder all connections and cut off excess leads.

PROCEED TO PICTORIAL 2-4.

PICTORIAL 2-3

The steps performed in this Pictorial are in this area of the circuit board.

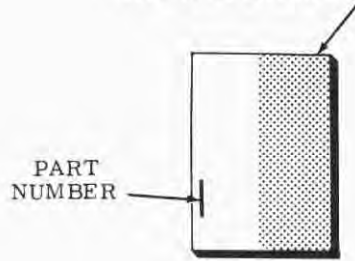

START



Receiver Circuit Board-Continued.

- () 10 μ F electrolytic.
- () 10 μ F electrolytic.
- () 10 μ F electrolytic.
- () .02 μ F disc.
- () Solder all connections and cut off excess leads.
- () .02 μ F disc.
- () .005 μ F disc.
- () 10 μ F electrolytic.
- () .01 μ F disc.
- () .02 μ F disc.
- () Solder all connections and cut off excess leads.

NOTE: Solder the leads of each transistor as you install it.

- () Install 2N3391 transistors (#417-91) at Q8, Q11 and Q12. Place the base (B), emitter (E), and collector (C) leads in their proper holes as shown below. Be sure to position the flat on the transistor in line with the flat outline on the circuit board.

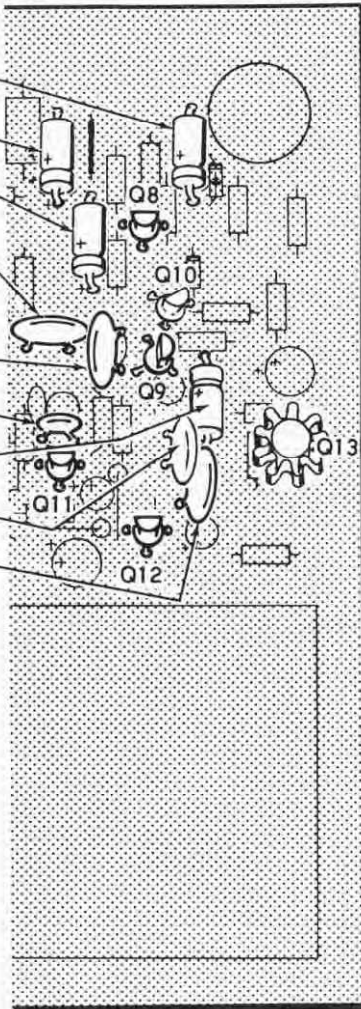
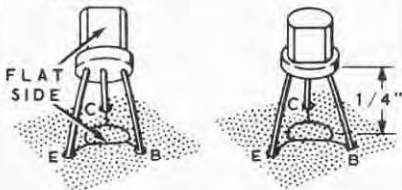

CONTINUE



- () Install a 2N3393 transistor (#417-118) at Q9.

- () Install a #417-201 transistor at Q10.

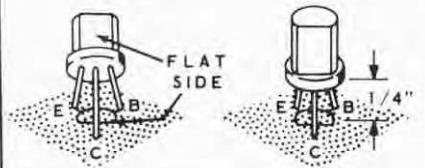

- () Install a heat sink (#215-8) on a 2N1274 (#417-152) transistor.

START HEAT SINK ON SMALL END OF NUT STARTER

SLIDE HEAT SINK ONTO TRANSISTOR Q13

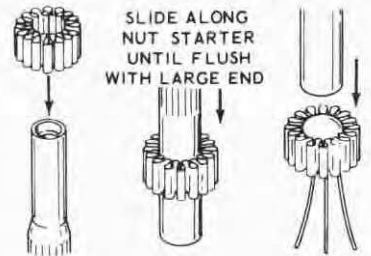

- () Place a 1/2" length of black sleeving on each lead of the 2N1274 transistor. Install this transistor at Q13. The tab is close to the emitter.

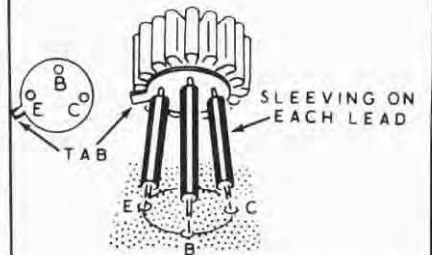

- () Make sure all connections are soldered, and cut off any excess leads.

PICTORIAL 2-4

PROCEED TO PICTORIAL 2-5.

START



Receiver Circuit Board-Continued

NOTE: Solder the connections of each part as it is installed.

- () Install 2N3694 (#417-171) transistors at Q4, Q5, Q6, and Q7. Line up the wide space between the C and E transistor leads with the correct circuit board holes. Then insert the transistor leads as shown into the holes and position the transistor 1/4" away from the circuit board.

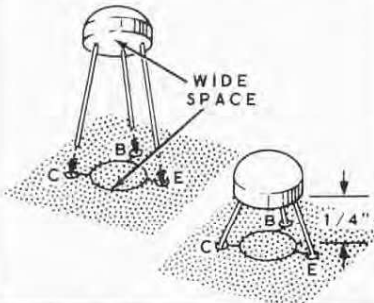

- () 1000 μ F electrolytic. Position the plus (+) marks together.

- () 10 μ F electrolytic. Position the plus (+) marks together.

- () Install a zener diode (#56-67). Appearance may vary.

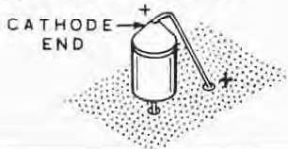

The steps performed in this Pictorial are in this area of the circuit board.

PART NUMBER

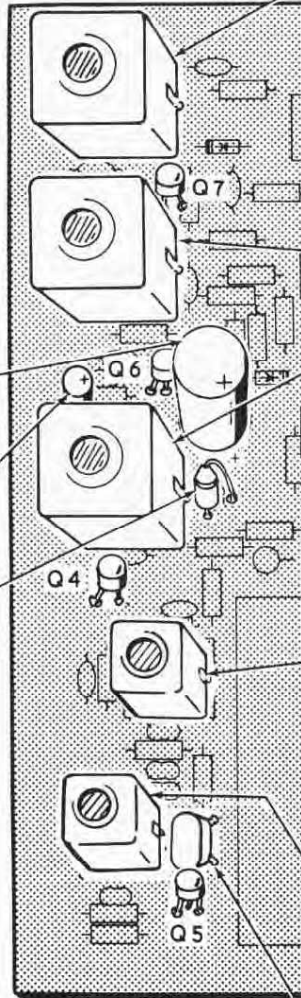
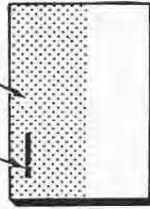

CONTINUE



NOTE: Do NOT attempt to solder pins which do not actually contact the foil.

- () Install transformer #52-117. Do NOT solder the pin indicated.

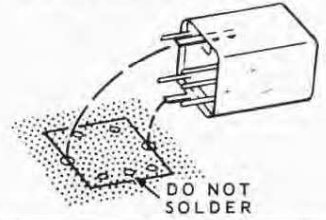

- () Install a #52-116 transformer. Note the arrangement of pin spacing.

- () Install a #52-116 transformer.

- () Hold a #40-678 coil with the pins pointing directly toward you. Cut off the pin indicated in the bottom view below:

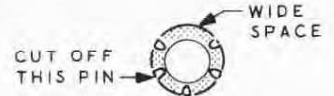

- () Install coil #40-678.

- () Install a coil shield over this coil. Do NOT remove liner.

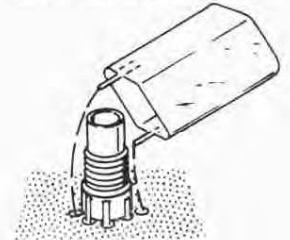

- () Install coil #40-681. Match the dot on the coil to the dot on the board.

- () Install a coil shield over coil #40-681. Do NOT remove liner.

- () 26.965 MHz crystal.

- () Be sure all leads are soldered to the foil and clip off excess lead lengths from diodes and transistors.

PICTORIAL 2-5

PROCEED TO PICTORIAL 2-6

The steps performed in this Pictorial are in this area of the circuit board.

PART NUMBER

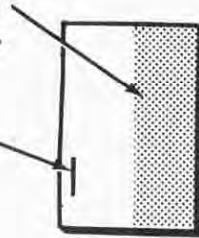

CONTINUE



START



Receiver Circuit Board-Continued

NOTE: Solder the connections of each part as it is installed.

Make sure the plus (+) mark on each electrolytic capacitor and the plus (+) mark on the circuit board are positioned together.

() 10 μ F electrolytic.

() 2 μ F electrolytic.

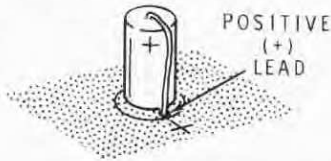

() 10 μ F electrolytic.

() 250 μ F electrolytic.

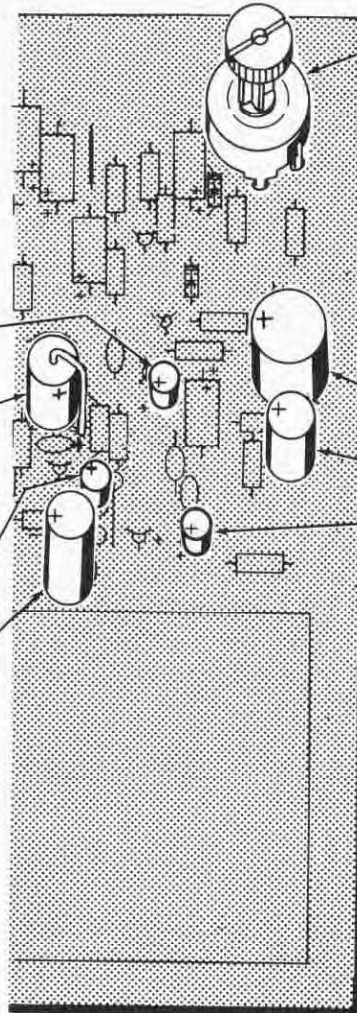

() Install a 30 Ω control. Do not cut off lugs.

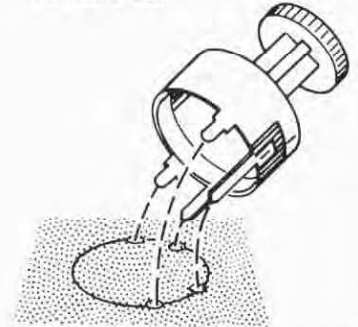

() 1000 μ F electrolytic. NOTE: This capacitor will not set against the circuit board due to other components.

() 50 μ F electrolytic.

() 10 μ F electrolytic.

NOTE: One 2200 Ω (red-red-red) and one 22 k Ω (red-red-orange) resistor should remain. These parts will be mounted after the initial tests.

() Make sure that all leads are properly soldered.

Lay this circuit board aside and proceed to Chassis Assembly.

FINISH

PICTORIAL 2-6

INITIAL TESTS

Visually examine the Transceiver wiring very carefully for possible short circuits (such as resistor or capacitor leads contacting the chassis), solder bridges between foils on the circuit boards, or terminal strip lugs touching shield plates. Also be sure no wire clippings or solder drops are still in the chassis. Check all connections to make sure they are soldered.

IMPORTANT: Specifically check to make sure that:

1. The final plate coil is not touching the antenna link coil, and that neither coil is touching any other point it should not touch.
2. Dual capacitor AG is installed and connected exactly as shown in Detail 3-3F (fold-out from Page 33).
3. On all printed circuit boards, the + marks on all electrolytic capacitors match similar marks lettered on the circuit boards.
4. The end of the yellow wire from grommet AH is still taped.

If there are any short circuits or leakage paths, serious damage may result to the transistors, tubes, power transformer, or other components, when power is applied. For this reason, it is important that the following checks be made before proceeding to the Testing and Alignment instructions.

Refer to the In Case Of Difficulty section of the Manual (Page 89) if you do not obtain the correct response in any of the following steps.

Set the controls as follows:

- () FINAL LOAD: Capacitor plates fully meshed.
- () FINAL TUNE: Capacitor plates half meshed.
- () DRIVER TUNE: Capacitor plates fully meshed.
- () CRYSTAL - VFO switch: X1 position.
- () VOLUME: OFF position.
- () FUNCTION: BATT SAVER position.
- () RECEIVER TUNING: Dial pointer set to 144 MHz.
- () SQUELCH: Pushed in and turned fully clockwise.
- () METER ZERO: Turn the screwdriver slot fully clockwise. (Control located on rear panel.)
- () BIAS CONTROL: Fully counterclockwise. (Control located on right rear corner of the receiver circuit board.)



- () Check to see that the following leads are not connected or touching any metal.

On top of the chassis:

Black lead coming from grommet AL,
Red lead coming from grommet AL.

On the bottom of the chassis:

Yellow lead coming from grommet AH.

Refer to Figure 1-1 (fold-out from Page 60) for the following steps. For clarity, most of the small parts and wiring have been omitted.

An ohmmeter will be used to make the following resistance measurements. Before making the first reading, determine the polarity of your meter leads in the next three steps.

- () Set the ohmmeter range switch to the R x 1000 (or higher) range.
- () Connect the ohmmeter leads to the terminals of the Transceiver panel meter so that an upscale meter reading is obtained.
- () Use the ohmmeter lead connected to the positive (+) panel meter terminal as the positive lead for the following measurements. For easy identification (unless the lead is already color coded) you may wish to mark the positive lead with an adhesive tape "flag".

NOTE: The following resistance readings were taken with a Heath Model IM-11 VTVM (vacuum tube voltmeter). Readings may vary $\pm 20\%$. Connect the negative lead of the ohmmeter to the GROUND post on the rear panel. Do not remove this lead until instructed to do so.

<u>POWER PLUG</u>	<u>MINIMUM READINGS</u>
() Pin 1	1.5 Ω
() Pin 2	INF
() Pin 3	INF
() Pin 4	INF
() Pin 5	.5 Ω
() Pin 6	INF
() Pin 7	250 Ω
() Pin 8	0 Ω
() Pin 9	greater than 50 k Ω
() Pin 10	INF
() Pin 11	INF
() Place the ohmmeter positive (lead) probe on pin 6 of the POWER plug, and move the FUNCTION switch to RCVR TRANS. The meter should read 1.5 Ω .	
() With the ohmmeter positive probe still on pin 6 of the POWER plug, move the function switch to SPOT. The meter should read 1.5 Ω . Return the FUNCTION switch to BATT SAVER POSITION.	

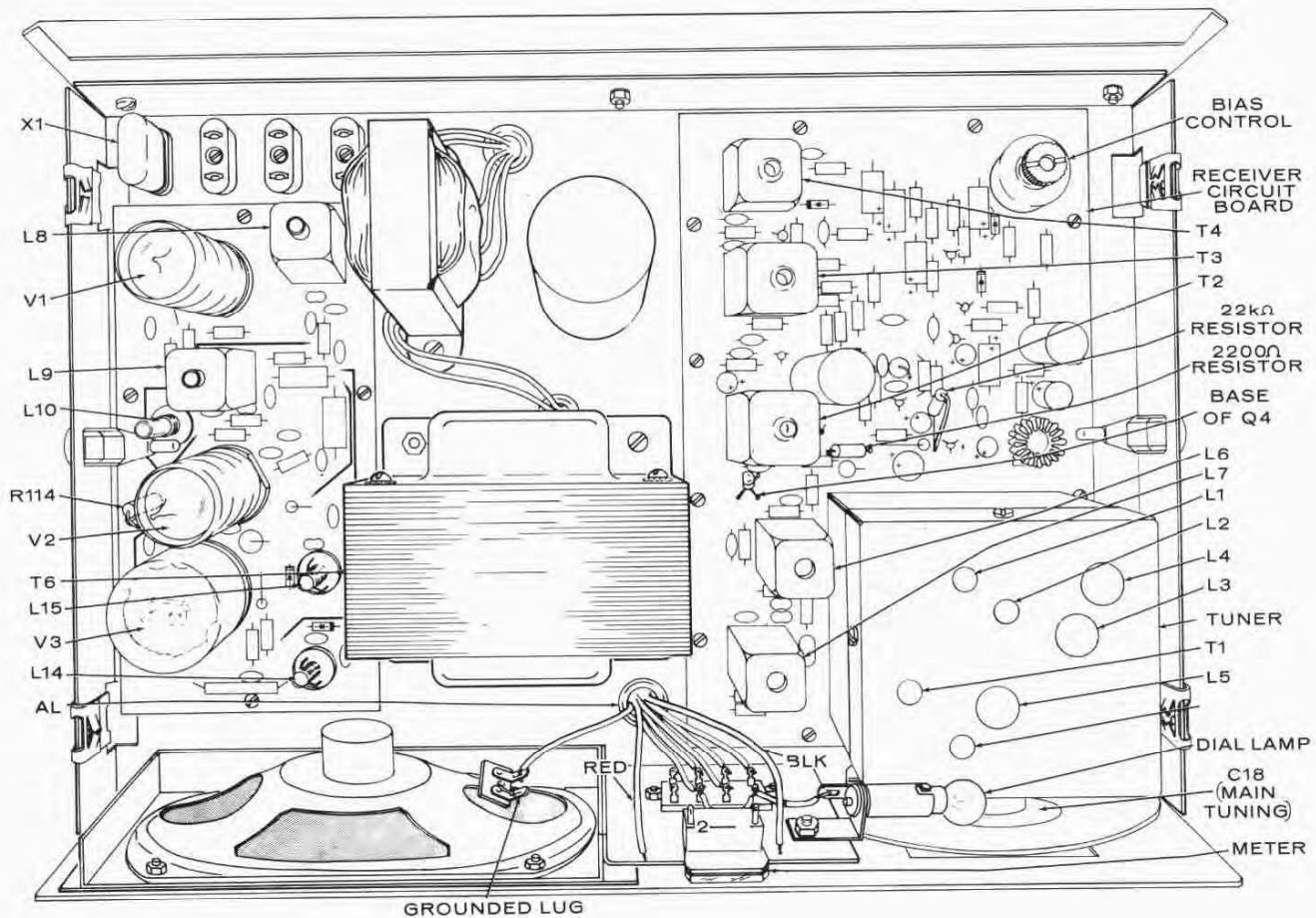

FIGURE 2-1

- () Remove the negative lead of the ohmmeter from the GROUND post and connect it to pin 3 of the POWER plug.
- () Connect the ohmmeter positive probe to pin 2 of the POWER plug. Turn the VOLUME control on. The meter should read 0 Ω . Return the control to the OFF position. The meter should read infinity (∞).
- () Connect the ohmmeter positive probe to pin 10. Turn the VOLUME control on. The meter should read 4 Ω if the unit is wired for 120 VAC, or 8 Ω if wired for 240 VAC.
- () Return the VOLUME control to the OFF position. The meter should read infinity.
- () Remove the negative lead of the ohmmeter from pin 3 of the POWER plug and replace it on the GROUND post.
- () Connect the ohmmeter positive probe to the end of feedthrough capacitor CA. The meter reading must exceed 1 megohm.
- () Connect the ohm meter positive probe to lug 3 of terminal strip CM. The meter should read greater than 50 k Ω .
- () Connect the ohmmeter positive probe to lug 1 of capacitor AG. The meter should read 40 k Ω or larger.
- () Connect the ohmmeter positive probe to point E on the receiver circuit board. The meter should read 200 Ω or more.
- () Connect the ohmmeter positive probe to lug 5 of terminal strip AP. The meter should read 300 k Ω or larger. Press in on the microphone button. The meter should now read less than .5 Ω . Release the microphone button.

NOTE: In some of the following steps it will take a few seconds for the ohmmeter to reach its full reading. Take the resistance reading after the meter needle has completed its travel.

The following readings should be obtained from the VFO POWER socket,

- () Pin 1 0 Ω
- () Pin 2 1.5 Ω
- () Pin 4 Greater than 50 k Ω
- () Pin 8 Infinity
- () Connect the ohmmeter positive probe to the center lug of the VFO INPUT. The meter should read infinity.
- () Connect the ohmmeter positive probe to the center lug of the ANTENNA socket. The meter should read infinity.

- () Connect the ohmmeter positive probe to lug 1 of terminal strip AP. The meter should read less than .5 Ω . Press in on the microphone button. The meter should now read 3 Ω . Release the microphone button.
- () Remove the negative lead from the GROUND post.

WARNING: If any meter readings outside of the stated range were obtained, DO NOT CONNECT THE LINE PLUG INTO THE AC POWER OUTLET. Recheck your work and refer to In Case Of Difficulty on Page 89.

This completes the Initial Tests. Proceed to the Alignment section.

- () Remove the negative lead of the ohmmeter from the GROUND post and connect it to pin 3 of the POWER plug.
- () Connect the ohmmeter positive probe to pin 2 of the POWER plug. Turn the VOLUME control on. The meter should read 0 Ω . Return the control to the OFF position. The meter should read infinity (∞).
- () Connect the ohmmeter positive probe to pin 10. Turn the VOLUME control on. The meter should read 4 Ω if the unit is wired for 120 VAC, or 8 Ω if wired for 240 VAC.
- () Return the VOLUME control to the OFF position. The meter should read infinity.
- () Remove the negative lead of the ohmmeter from pin 3 of the POWER plug and replace it on the GROUND post.
- () Connect the ohmmeter positive probe to the end of feedthrough capacitor CA. The meter reading must exceed 1 megohm.
- () Connect the ohm meter positive probe to lug 3 of terminal strip CM. The meter should read greater than 50 k Ω .
- () Connect the ohmmeter positive probe to lug 1 of capacitor AG. The meter should read 40 k Ω or larger.
- () Connect the ohmmeter positive probe to point E on the receiver circuit board. The meter should read 200 Ω or more.
- () Connect the ohmmeter positive probe to lug 5 of terminal strip AP. The meter should read 300 k Ω or larger. Press in on the microphone button. The meter should now read less than .5 Ω . Release the microphone button.
- () Connect the ohmmeter positive probe to lug 1 of terminal strip AP. The meter should read less than .5 Ω . Press in on the microphone button. The meter should now read 3 Ω . Release the microphone button.
- () Remove the negative lead from the GROUND post.

NOTE: In some of the following steps it will take a few seconds for the ohmmeter to reach its full reading. Take the resistance reading after the meter needle has completed its travel.

The following readings should be obtained from the VFO POWER socket.

- () Pin 1 0 Ω
- () Pin 2 1.5 Ω
- () Pin 4 Greater than 50 k Ω
- () Pin 8 Infinity
- () Connect the ohmmeter positive probe to the center lug of the VFO INPUT. The meter should read infinity.
- () Connect the ohmmeter positive probe to the center lug of the ANTENNA socket. The meter should read infinity.

WARNING: If any meter readings outside of the stated range were obtained, DO NOT CONNECT THE LINE PLUG INTO THE AC POWER OUTLET. Recheck your work and refer to In Case Of Difficulty on Page 89.

This completes the Initial Tests. Proceed to the Alignment section.

ALIGNMENT

CAUTION: BEFORE APPLYING POWER TO THE TRANSCEIVER, IT SHOULD BE NOTED THAT LETHAL VOLTAGES ARE PRESENT BOTH ABOVE AND BELOW THE CHASSIS. DO NOT TOUCH ANY VOLTAGE POINTS WITH YOUR HANDS. USE WELL INSULATED TOOLS FOR ANY ADJUSTMENTS.

TO REDUCE SHOCK HAZARD, CONNECT A LEAD FROM A GOOD EARTHGROUND TO THE GROUND LUG ON THE REAR APRON OF THE CHASSIS.

Refer to Figure 2-1 (fold-out from this Page) to locate any parts mentioned in this section.

TRANSMITTER ALIGNMENT

A 50 ohm, noninductive load for the Antenna terminal is required to align the transmitter. The Heathkit "Cantenna" is recommended. If a Cantenna is not available, you can refer to Figure 2-2 and construct a dummy load from two 100 ohm, 2 watt resistors and a phono plug, which have been furnished. CAUTION: The total power dissipation rating of the two resistors is 4 watts, whereas the actual power output will be several times this power. To avoid burning out the resistors, the microphone button can be depressed for only the minimum amount of time required to make each adjustment. After each adjustment, let the resistors cool for at least twice the time the transmitter was ON.

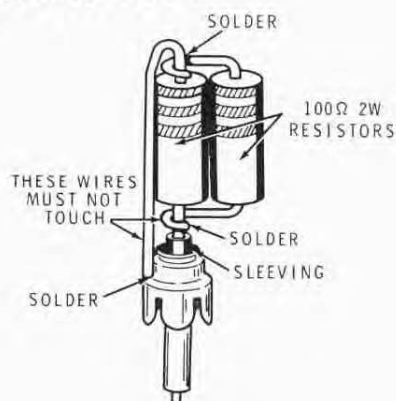

Figure 2-2

In some of the following steps, an illustration of the meter scale is presented. The exact location of the meter needle will vary between different units, but it should be in the general area shown. The horizontal arrow beneath the meter face shows the direction of needle movement to accomplish the adjustment being described.

- () Strip 1/4" of insulation from each end of the remaining black wire.
- () Strip 1/4" of insulation from each end of the remaining red wire.

NOTE: To "tack solder" a wire, as in the following step, lay the bared end of the wire on the solder lug and solder it with a small amount of solder. Do not bend the wire around the lug or push it through the hole in the lug.

- () Refer to Figure 2-3 and tack solder one end of the prepared black wire to the negative (-) lug (lug 1) of the meter (S-1). Leave the other end of the wire free. This wire will be removed later.
- () Tack solder one end of the prepared red wire to the positive (+) lug (lug 2) of the meter (S-1). Leave the other end of the wire free. This wire will be removed later.

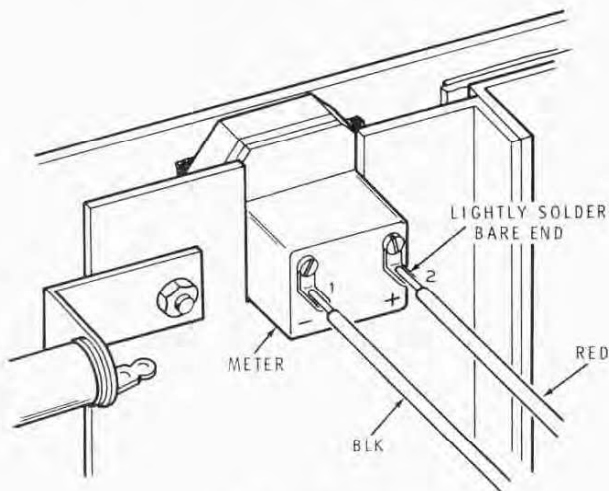

Figure 2-3

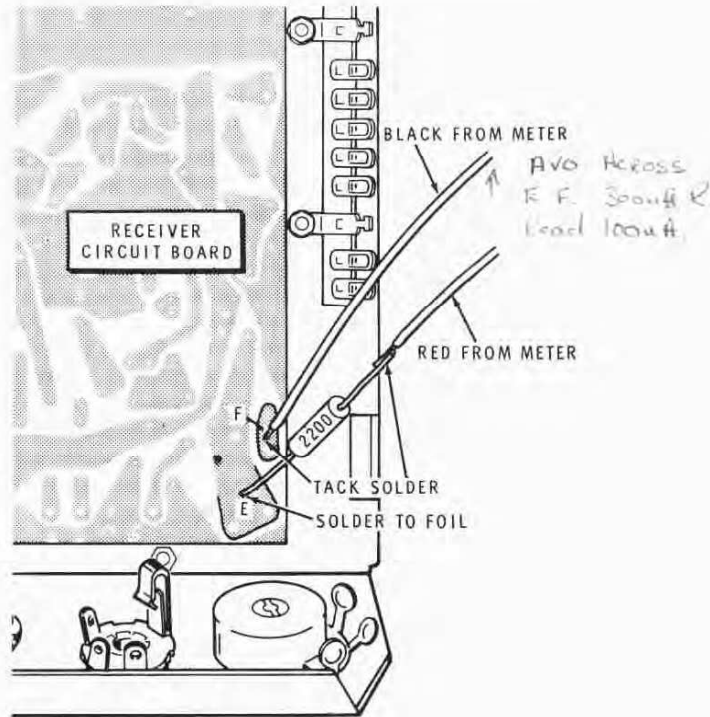
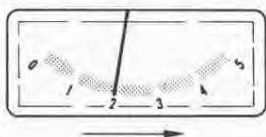

Figure 2-4

- () Refer to Figure 2-4 and tack solder one end of the remaining 2200 Ω (red-red-red) resistor to E on the foil side of the receiver circuit board (S-1).
- () Connect the free end of the red wire coming from the meter to the free end of the 2200 Ω resistor (S-1).
- () Connect the free end of the black wire coming from the meter to point F on the receiver circuit board (S-1).
- () Turn the Transceiver top side up and connect the line cord (11-pin socket) to the power plug on the rear panel.
- () Make sure the VOLUME control is at OFF, and plug the other end of the AC line cord into the appropriate power source.
- () Turn the Transceiver on by turning the VOLUME control clockwise.

- () Refer to Figure 2-1 and adjust the BIAS control clockwise until the meter reads exactly 2.



NOTE: During the Alignment steps, it is necessary to turn the Transceiver over several times to get at points on both the top and the bottom of the chassis. As AC voltage is exposed at several points, even with the power switch OFF, you may wish to disconnect the end of the line cord from the wall outlet or other power source while the chassis is being turned over.

- () Turn the Transceiver off.
- () Disconnect the temporary red lead from the 2200 Ω resistor and the temporary black leads from F.
- () Remove the 2200 Ω resistor from E. It will be installed later.
- () Refer to Figure 2-5 and tack solder one lead of the 22 k Ω (red-red-orange) resistor to the foil shown on the receiver circuit board (S-1).

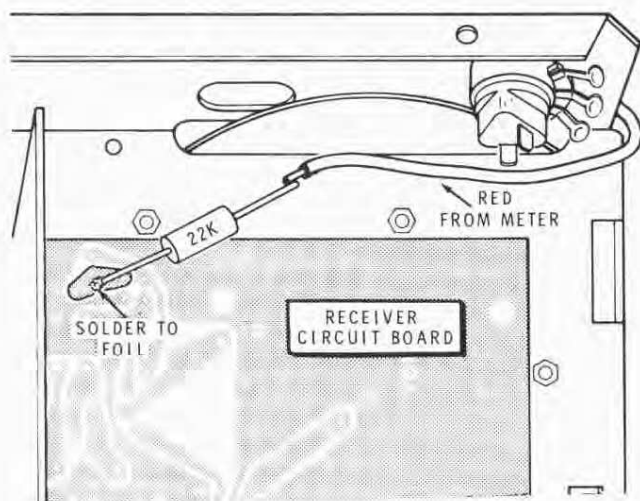
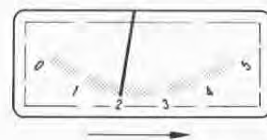

Figure 2-5

- () Connect the other lead of the resistor to the free end of the red wire from the meter (S-1).
- () Turn the Transceiver top side up.
- () Refer to Figure 2-1 and tack solder the free end of the black wire from the meter to the ground lug of the speaker (S-1).
- () Turn the Transceiver ON.
- () Adjust coil L7 for maximum meter deflection to the right. Then turn the coil slug an additional 1/4 turn in a clockwise direction.



- () Turn the Transceiver OFF.
- () Disconnect the black wire from the speaker ground lug, and the red wire from the 22 k Ω resistor.
- () Remove the 22 k Ω resistor from the foil of the receiver circuit board.
- () Refer to Figure 2-1 and install the 2200 Ω (red-red-red) resistor on the receiver circuit board. Solder both leads and trim off excess lead length.
- () Refer to Figure 2-1 and install the 22 k Ω (red-red-orange) resistor on the receiver circuit board in a vertical position. Solder both leads and trim off excess lead length.
- () Tack solder the red lead from the meter to the grounded terminal of the speaker (the lug to which the bare wire is connected).

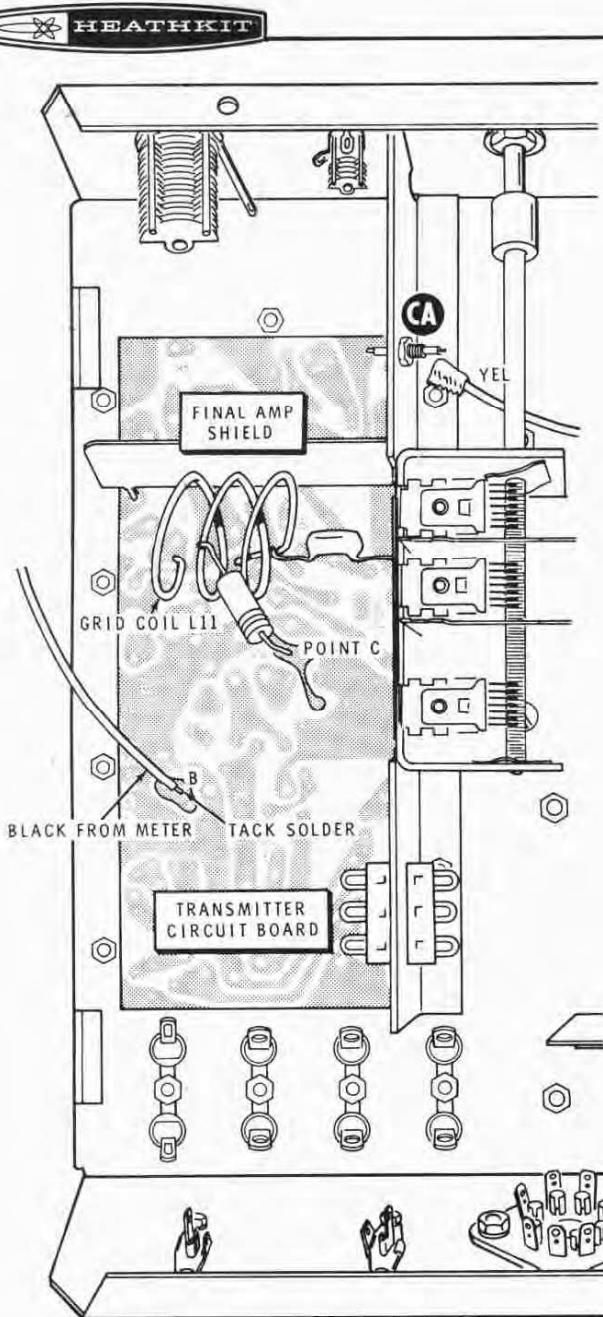
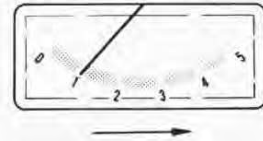

Figure 2-6

() Refer to Figure 2-6 and tack solder the black lead from the meter to point B on the transmitter circuit board (S-1).

() Turn the Transceiver top side up.

- () Turn the DRIVER TUNE knob to the 10 o'clock position.
- () Set the FUNCTION switch to the RCVR-TRANS position.
- () Make sure that the 8,06 MHz crystal supplied is in crystal socket X1.
- () Turn the unit ON. Be sure the pilot lamp and tube filaments light.
- () Insert the shorter end of the alignment tool into coil L8.
- () After allowing 60 seconds for warmup, press in on the microphone button and adjust coil L8 for maximum meter indication by turning the coil slug with the alignment tool. After a peak has been obtained, release the microphone button.



() Turn Transceiver OFF.

() Refer to Figure 2-6 and disconnect the black wire from point B on the transmitter circuit board. Then connect this wire to point C on the same board (S-1).

() Turn the Transceiver top side up.

() Turn unit ON and insert the alignment tool into coil L9.

() Allow unit to warm up again for 60 seconds. Then press in on the microphone button and adjust coil L9 for maximum indication. Release the microphone button.



- () Insert the alignment tool in coil L10. Press in on the microphone button and adjust coil L10 for MINIMUM reading. This indication may be just discernible in some units. Release the microphone button.



- () Press in on the microphone button and readjust coils L8 and L9 for MAXIMUM indication. Release the microphone button.

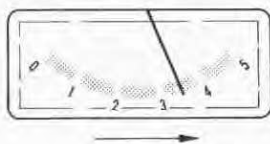

- () Turn the Transceiver bottom side up.

NOTE: In the next step, use the shorter end (thicker shaft) of the alignment tool to spread out (lengthen) coil L11 until it reaches the operating frequency. Insert the heavier end of the alignment tool between the turns of the coil and force them apart a little at a time.

- () Press the microphone button and adjust coil L11 for maximum meter deflection. Release the microphone button. NOTE: The adjustment of L11 may cause the meter to deflect full scale. If this happens, turn the slug of L9 counterclockwise enough to reduce the meter indication. Then obtain a peak on L11. Coil L9 will be repeaked later.

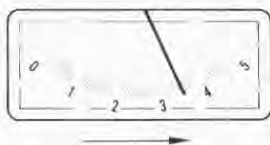

- () Turn the unit off.
- () Remove the masking tape from the end of the yellow lead coming from grommet AH. Touch the end of the lead to chassis ground (a spark may jump from the lead to the chassis). Then connect the end of the yellow lead to feedthrough capacitor CA (S-1).
- () Disconnect the temporary red and black wires connected to the meter. Save these wires for reuse later.

Refer to Figure 2-1 (fold-out from Page 66) for the following two steps.

- () Temporarily connect the black wire coming from grommet AL to lug 1 of the meter (S-1).
- () Temporarily connect the red wire coming from grommet AL to lug 2 of the meter (S-1).
- () Make sure a 50 ohm noninductive load is connected to the ANTENNA TERMINAL for the following steps.
- () Turn the Transceiver on. Turn the METER ZERO adjustment on the rear panel for "0" reading on the meter.

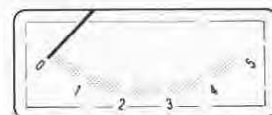

NOTE: When the Function switch is in the RCVR-TRANS position, the meter indicates relative power output and reads downscale. Downward deflection of the meter needle therefore means increased power output.



- () Press in on the microphone button. The meter should deflect to almost full scale. Adjust both the FINAL TUNE and FINAL LOAD knobs for MINIMUM indication of the meter.

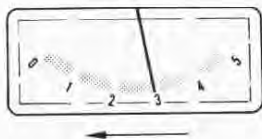

- () Adjust coil L9 for minimum indication on the meter. Release the microphone button.
- () Press the microphone button and adjust the DRIVER TUNE, FINAL TUNE and FINAL LOAD for MINIMUM indication. Talk into the microphone at a normal level. As you talk, the meter should "swing" farther down scale.



Refer to Figure 2-7, which shows the dimensions to which the coupling between the final plate coil and the antenna link coil should be adjusted. In some units you can adjust the coupling for a small additional output.

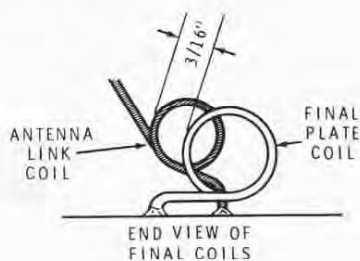

Figure 2-7

CAUTION: In the following adjustment, high voltage is present on the final plate coil; protect yourself from electrical shock! Keep in mind that if the final plate coil and the antenna link coil touch each other, several diodes will probably be damaged.

- () Turn the Transceiver bottom side up.
- () Be sure the Function switch is set to RCVR-TRANS. Then depress the microphone button.
- () Use the large end of the plastic nut starter to push the antenna link coil into or out of the final plate coil. Push a very small amount at a time. Adjust the antenna link coil for maximum relative power output (deflection to the left).



- () With the microphone button pressed in, turn the front panel knob to X2. If the meter goes to full scale, this indicates that the transmitter is operating only on its proper frequency and not on a spurious frequency. Release the microphone button and return the knob to X1.
- () Turn the Transceiver OFF.
- () Disconnect the red wire and the black wire from the panel meter.
- () Tack solder the temporary red wire to lug 2 of the panel meter (S-1). Connect the other end of this wire to the grounded lug of the speaker (S-1).

- () Tack solder the temporary black wire to lug 1 of the panel meter (S-1). Tack solder the other end of this wire to the AGC terminal on the foil side of the receiver circuit board (S-1). A yellow wire has been previously connected to this terminal.
- () Disconnect the lead of the 100 pF disc capacitor from the ground foil near the ANT terminal and connect this lead to the ANT terminal (S-1).
- () Turn the Transceiver top side up.
- () Press the microphone button and use the alignment tool to adjust the slug in coil L15 for minimum indication on the panel meter.
- () Remove and discard the temporary red wire and the temporary black wire.
- () Connect the red wire coming from grommet AL to lug 2 of the panel meter (S-1).
- () Connect the black wire coming from grommet AL to lug 1 of the panel meter (S-1).

This completes the alignment of the transmitter portion of your Transceiver.

You can measure the power input to the final amplifier by connecting a milliammeter (set to measure at least 150 mA) across resistor R114, the cathode resistor of tube V3. The meter will indicate total tube current, from which the screen grid and control grid current must be subtracted.

An example of this would be:

Total cathode current	100 mA
<u>Less:</u> screen current	10 mA
grid current	2 mA
Plate current	<u>88 mA</u>

Plate current in Amperes	.088 A
Plate voltage	<u>300 VDC</u>
Watts plate input	26.4

Another way to measure the approximate power input to the final amplifier is to measure the voltage drop across R114. For each one volt drop across this resistor, 10 mA of current is flowing. Thus, a 7.5 volt drop means 75 mA of current is flowing. Multiply this by the plate voltage, and decrease the result by 1/5 to allow for screen and grid current:

R114 voltage drop	11.0 VDC
Total cathode current (approx.)	.11 A (110 mA)
Plate voltage	<u>300 VDC</u>
Total watts	33.0
Less 1/5 for screen and grid	<u>6.6</u>
Watts plate input (approx.)	26.4

RECEIVER ALIGNMENT

The tuner for the receiver has been aligned at the factory. This Receiver Alignment Procedure is therefore confined to the second oscillator, mixer, and low frequency IF stages.

Two methods of aligning the receiver are presented here: "Alignment With Instruments" and "Alignment Without Instruments." The first method, the more accurate of the two, is performed with an RF signal generator and an 11 megohm input voltmeter. The second method uses an "on the air" signal with the Transceiver meter for a tuning indicator. Use the method that best fits your needs.

ALIGNMENT WITH INSTRUMENTS

- () Set the FUNCTION switch to the BATT. SAVER position.
- () Connect the voltmeter, set to the lowest AC range, across the speaker terminals.
- () Make sure the SQUELCH control is turned fully clockwise and that the knob is pushed in.
- () Turn the Transceiver on and adjust the VOLUME control to a comfortable level.
- () Connect the ground lead of the RF signal generator to the Transceiver chassis and the "hot" lead through a $.01 \mu\text{F}$ capacitor to the base (B) of transistor Q4. (See Figure 2-1).
- () Adjust the signal generator for a frequency of 2 MHz, modulated 30% at 400 Hz. Adjust the RF output for an indication on the voltmeter.
- () Adjust the slug of transformer T4 for a MAXIMUM reading on the voltmeter.

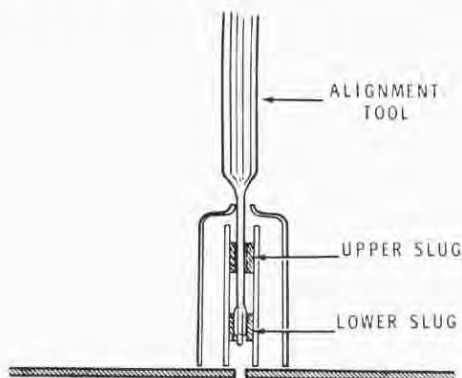

Figure 2-8

- () Refer to Figure 2-8 and adjust both the upper and lower slugs in transformer T3 for a maximum reading on the voltmeter. Start with the slug closest to the circuit board. Keep reducing the generator output as the slugs are tuned so that a minimum recognizable reading is maintained on the voltmeter.
- () In a similar manner, adjust both slugs in transformer T2.
- () Readjust the slugs in T2, T3, and T4 for a MAXIMUM reading. Remember to keep the generator output low to obtain a sharp indication.
- () Disconnect the hot lead of the generator and the $.01 \mu\text{F}$ capacitor from the base of Q4.

- () Refer to Figure 2-1 and place one lead of the .01 μ F capacitor in the hole for T1 in the top of the tuner. Attach the hot lead of the signal generator to the other capacitor lead. Set the generator to 24.960 MHz.
- () Adjust coil L6 for maximum indication on the voltmeter.
- () Disconnect the voltmeter and the signal generator.

NOTE: For maximum performance, repeat the above series of adjustments.

This completes the Alignment With Instruments. Proceed to "T-R Switching Alignment."

ALIGNMENT WITHOUT INSTRUMENTS

NOTE: If you are not familiar with VHF antenna practices, look ahead to Antenna Considerations on Page 80.

Set the controls of the Transceiver as follows:

- () FUNCTION: RCVR-TRANS
- () CRYSTAL-VFO: X1
- () SQUELCH: Fully clockwise
- () ANL: Push in
- () Turn the Transceiver ON with the VOLUME knob, and adjust for a reasonable amount of background noise.
- () Set the FUNCTION switch to SPOT.
- () Turn the MAIN TUNING near 145.08 MHz to the harmonic of the 8.06 MHz crystal previously installed in crystal socket X1. Adjust the MAIN TUNING and the DRIVER TUNE knobs for maximum meter needle deflection.

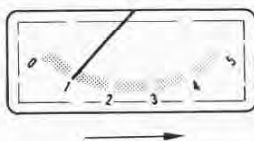

Refer to Figure 2-1 and use the alignment tool to adjust the following transformers and coils for maximum meter deflection.

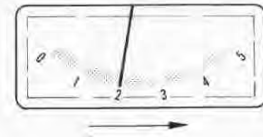

- () T4
- () T3
- () T2
- () L6

- () Connect a 2-meter antenna to the ANTENNA connector on the rear apron.

- () Set the FUNCTION switch to RCVR-TRANS.

- () Tune in a signal near the middle of the tuning range which gives meter reading of 1 or 2. Again adjust the following meters and coils for maximum meter reading.

- () T4
- () T3
- () T2
- () L6

NOTE: If the equipment needed for Alignment With Instruments becomes available later, you should then realign the receiver to make sure that you are receiving the very best performance from your Transceiver.

This completes Alignment Without Instruments. Proceed to "T-R Switching Alignment."

T-R SWITCHING ALIGNMENT

WITH INSTRUMENTS

Equipment needed

1. An RF signal generator with a 50 Ω output impedance that will tune from 142 to 149 MHz with 30% internal AM modulation at 1000 Hz.
2. An 11 megohm input voltmeter.

Alignment Procedure

- () Set the FINAL LOAD knob so the capacitor plates are fully meshed.
- () Place the FUNCTION switch in the TRANS-RCVR position.
- () Connect the voltmeter across the speaker terminals. Set the voltmeter to read AC in the lowest range.
- () Connect the Transceiver to the power source and turn it on.
- () Connect the RF generator to the antenna input.
- () Set the generator for an internal modulation of 30% at 1000 Hz.
- () Turn the MAIN TUNING to read 146 MHz and adjust the generator for an approximate midscale reading on the voltmeter. Note the voltmeter needle position; this position will be called the "Reference Point."
- () Adjust the FINAL TUNE knob for a maximum increase in the meter deflection.
- () Adjust coil L14 to reduce the meter deflection to the "Reference Point." Refer to Figure 2-1 to locate L14.
- () Repeat the two preceding adjustments until you obtain a minimum amount of meter deflection when adjusting the FINAL TUNE knob.

This completes the T-R switching alignment with instruments. Disconnect the RF generator and voltmeter from the Transceiver. Proceed to the "Final Assembly." NOTE: The tuner should require no alignment, although tuner alignment information is furnished in case it should be needed for maintenance purposes at some time in the future.

WITHOUT INSTRUMENTS

- () Set the FINAL LOAD knob so the capacitor plates are fully meshed.
- () Place the CRYSTAL-VFO switch in the X1 position.
- () Place the FUNCTION switch in the SPOT position.
- () Connect the Transceiver to the power source and turn it on.
- () Tune the MAIN TUNING knob to obtain a maximum panel meter deflection at the SPOT frequency. Note the meter needle position. This position will be called the "Reference Point."
- () Adjust the FINAL TUNE knob for a maximum increase in the meter deflection.
- () Adjust coil L14 to reduce the meter deflection to the "Reference Point." Refer to figure 2-1 to locate coil L14.
- () Repeat the two preceding adjustments until you obtain a minimum amount of meter deflection when adjusting the FINAL TUNE knob.

This completes the T-R switching alignment without instruments. Proceed to the Final Assembly. (NOTE: The Tuner should require no alignment, although tuner alignment information is furnished in case it should be needed for maintenance purposes at some future time.)

TUNER ALIGNMENT

The tuner is prealigned as it comes from the factory. However, these alignment instructions are included should realignment be needed some time in the future.

EQUIPMENT NEEDED

1. An RF signal generator with a 50 Ω output impedance that will tune from 142 to 149 MHz with 30% internal AM modulation at 1000 Hz.
2. An 11 megohm input voltmeter.
3. An accurate source of calibrated signal at 143.2 and 148.2 MHz (referred to as a "calibrator").

ALIGNMENT PROCEDURE

- () Connect the voltmeter across the speaker terminals.
- () Connect the calibrator to the ANTENNA input on the rear panel.
- () Connect the Transceiver to its power source.
- () Set FUNCTION switch to TRANS-RCVR.
- () Turn the Transceiver on.
- () Set the dial and calibrator to 148.2 MHz.
- () Adjust capacitor C16 for MAXIMUM signal indication either on the voltmeter or on the front panel meter.
- () Set the dial and calibrator to 143.2 MHz and adjust coil L5 for MAXIMUM indication by expanding or contracting the coil with an insulated alignment tool through its access hole in the tuner cover.
- () Set the dial and calibrator back to 148.2 MHz and readjust C16.
- () Set the dial and calibrator to 143.2 MHz and readjust coil L5.
- () Repeat the above two steps until the dial tracks properly.
- () Disconnect the calibrator and connect the RF signal generator in its place.
- () Turn the dial to read 146 MHz and adjust the generator for an indication on the voltmeter. The generator should be set for internal modulation of 30% at 1000 Hz.
- () Remember to keep the RF output of the generator low and adjust coils L1 and L2 for MAXIMUM output. Do not position the slug of coil L1 at the bottom of its form, as the slug may stick and break.
- () Turn the dial to 147 MHz and tune the generator for an indication. Adjust coil L4 for maximum output.
- () Turn the dial to 145 MHz and tune the generator for an indication. Adjust coil L3 for maximum output.
- () Repeat the procedure for coils L3 and L4 until no further output is obtained.
- () Return the dial and generator to 146 MHz and readjust coils L1 and L2 for maximum output. The slug of coil L2 must be turned counterclockwise only (toward the top of its form).
- () Adjust both slugs of transformer T1 for maximum output at 146 MHz.
- () Recheck the dial calibration and readjust if needed.

This completes the Tuner alignment.

CRYSTAL CONSIDERATIONS

The Transceiver is furnished with an 8060 kHz crystal in an HC-6U type holder. This crystal produces a transmit frequency of 145.080 MHz, the 18th harmonic of the crystal frequency. When purchasing crystals, determine the crystal frequency by the following formula:

$$\text{CRYSTAL FREQUENCY (MHz)} = \frac{\text{DESIRED TRANSMIT FREQUENCY (MHz)}}{18}$$

Multiply the answer by 1000 to convert to kHz (kilohertz). The result should be in the range of 8000 to 8222 kHz for frequencies within the two meter band.

The Transceiver is furnished with one socket for type HC-6U crystals and three sockets for type FT-243 crystals. As the crystal furnished is of the HC-6U type, any extra crystals which are purchased should be of the FT-243 type. Some suppliers can furnish HC-6U to FT-243 adapter pins.

Include the following specifications when ordering crystals:

C loading. 9 pF.
Drive level. 15 mA at 13 Ω .
Effective resistance. 25 Ω .

Crystal socket designations X1, X2, X3, and X4 are lettered at the rear of the transmitter circuit board.

IN CASE OF DIFFICULTY

This section of the Manual is divided into three parts: General Tests, Transmitter Troubleshooting Chart, and Receiver Troubleshooting Chart. Refer to the General Tests first for any problems that occur right after the kit is completed. Then refer to the Troubleshooting Charts.

Refer to the Circuit Board X-Ray Views (Pages 116 and 117) and the Chassis Photographs (Pages 114 and 115) for the location of components on

the circuit boards and chassis. The Block Diagram (fold-out from Page 98) and Schematic Diagram (fold-out from Page 119) will also help you locate the cause of difficulty.

NOTE: In an extreme case where you are unable to resolve a difficulty, refer to the Service and Warranty section of the "Kit Builders Guide", and to the "Factory Repair Service" information on Page 88 of this Manual.

GENERAL TESTS

1. Recheck the wiring. Trace each lead in color pencil on the Pictorial as it is checked. It is frequently helpful to have a friend check your work. Someone who is not familiar with the unit may notice something consistently overlooked by the kit builder.
2. About 90% of the kits that are returned for repair do not function properly due to poor connections and soldering. Therefore, many troubles can be eliminated by reheating all connections to make sure they are soldered as described in the Soldering section of the Kit Builders Guide.
3. Check to be sure all transistors and tubes are in their proper locations. Make sure all tubes light when the Function switch is in the RCVR/TRANS and SPOT positions. **MAKE SURE EACH TRANSISTOR LEAD IS CONNECTED TO THE PROPER POINT.**
4. Check the values of the parts. Be sure the proper parts have been wired into each circuit as shown in the Pictorial Diagrams. It would be easy, for example, to install a 22

k Ω (red-red-orange) resistor where a 220 k Ω (red-red-yellow) resistor should have been installed.

5. Check for bits of solder, wire ends, or other foreign matter which may be lodged in between circuit board foils or wiring.
6. If, after careful checks, the trouble is still not located and a voltmeter is available, check the voltage readings against those shown on the Voltage Chart (fold-out from Page 113). All voltage readings were taken with an 11 megohm input voltmeter. Voltages may vary as much as $\pm 20\%$.
7. A review of the Circuit Description will also help you to know where to look for the trouble.

NOTE: Breaks in the foil of the circuit board can be detected by placing a bright light under the foil side of the board and looking through the board from the lettered side. A break will appear as a hairline crack in the foil.

TRANSMITTER TROUBLESHOOTING CHART

SYMPTOM	POSSIBLE CAUSE	CURE
No filament voltage.	<ol style="list-style-type: none"> 1. Filaments shorted. Check brown wire jumpers on top of transmitter circuit board. 2. Power plug or socket wired wrong. 	<ol style="list-style-type: none"> 1. Arrange jumper wires so they are not touching any component leads or circuit board pins. 2. Wire correctly.
Tube V1A will not oscillate.	<ol style="list-style-type: none"> 1. Tube V1 defective. 2. Ground end of the 150 Ω cathode resistor of V1A not grounded when Mic button is pressed. 3. Cathode common line not grounding. Measure with 11 megohm input voltmeter at point <u>U</u> on the circuit board. When Mic button is pressed, this voltage should be near zero. 4. Crystal defective. You should be able to measure -7.5 VDC at point N. 5. No B+ at pin 6 of V1A (open R104). 6. No change in voltage at pin 7 of V1A from receive to transmit mode (open resistor R102). 7. No crystal installed. 	<ol style="list-style-type: none"> 1. Check tube V1 on a tube checker. Replace with a good tube. 2. Check wiring and soldering of Function Switch. 3. Diode D101 "open". Remove the diode and check its forward and back resistance. The forward (cathode to anode) resistance should be approximately 5000 ohms. The resistance in the opposite direction should be over 1 megohm. Replace if necessary. 4. Replace crystal. 5. Replace resistor R104. 6. Install crystal.
No output from tripler tube V1B.	<ol style="list-style-type: none"> 1. Tube V1 defective. 2. Capacitor C174 may be shorted out by resistor R107. 3. No B+ at pin 1 of tube V1B (open resistor R108). 4. No change in cathode voltage at pin 8 from receive to transmit mode (open resistor R107). 5. No crystal installed. 	<ol style="list-style-type: none"> 1. Check tube on tube checker, or replace with a good tube. 2. Check for short circuit and rearrange the lead of C174. 3. Replace resistor R108. 4. Replace resistor R107. 5. Install crystal.
No output from tube V2. (No output reading at test point TP-C).	<ol style="list-style-type: none"> 1. No B+ at pin 7 of tube V2. 2. No change in voltage at pin 1 between receive and transmit modes. Should decrease on transmit (open resistor R111). 3. No Screen Voltage at pin 8 of V2 (open resistor R112 or shorted capacitor C116). 4. Tube V2 defective. 	<ol style="list-style-type: none"> 1. Open RFC1. 2. Replace resistor R111. 3. Replace defective component. 4. Check tube on tube checker or replace with a tube known to be good.
No voltage indication at TP-C. All stages working.	<ol style="list-style-type: none"> 1. Resistor lead from the bottom of circuit board at TP-C not cut off and shorting to the tube socket ground lug on the top side of the circuit board. 	<ol style="list-style-type: none"> 1. Reposition the resistor lead.

SYMPTOM	POSSIBLE CAUSE	CURE
No power output from tube V3.	<ol style="list-style-type: none"> 1. No change in voltage at cathode between receive and transmit modes. On transmit, voltage should be approximately 13 VDC, (open R114). 2. No Plate Voltage: open RFC, or open winding on Transformer T6. 3. Tube V3 defective. 	<ol style="list-style-type: none"> 1. Replace resistor R114. 2. Replace defective component. 3. Check tube on a tube checker, or replace with a tube known to be good.
Output is evident without a crystal or VFO in the circuit.	<ol style="list-style-type: none"> 1. Self oscillation of final amplifier. Cathode bypass capacitor not positioned according to instructions. 2. Lack of grid drive. Grid voltage in transmit mode should be at least -14 VDC. 3. Antenna not connected. 	<ol style="list-style-type: none"> 1. Reposition capacitor C309 and C121 properly, as directed in the steps. 2. Replace any defective components between the plate of V2 and the grid of V3.
High voltage short in the final amplifier plate coil.	<ol style="list-style-type: none"> 1. Final amplifier plate coil touching chassis. 2. Feedthrough capacitor C311 shorted. 3. C303 shorted. 	<ol style="list-style-type: none"> 1. Relocate coil away from the chassis. 2. Replace capacitor C311. 3. Replace V3. 4. Straighten plates.
Switching diodes D101, D102, and D204 burned out.	<ol style="list-style-type: none"> 1. Antenna link coil shorted to final amplifier plate coil. 	<ol style="list-style-type: none"> 1. Reposition coil L13, and replace diodes D101, D102 and D204.
No indication of relative power on the panel meter.	<ol style="list-style-type: none"> 1. Diode D301 installed backwards. 2. Capacitor C312 shorted. 3. Shorted coaxial cable from lug 3 of terminal strip CC to lug 10 of terminal strip AP. 	<ol style="list-style-type: none"> 1. Reverse diode D301. 2. Replace capacitor C312. 3. Unsolder both center conductors and measure with an ohmmeter from center conductor to the chassis. If it is shorted, replace the coaxial cable.
T-R Switch (See Page 112) not working properly.	<ol style="list-style-type: none"> 1. In the receive mode (to provide proper back bias) the cathode voltage of diode D102 should exceed its anode voltage by at least 10 VDC. If resistor R116 is open, this voltage will be low; if resistor R117 is open, this voltage will be high. 	<ol style="list-style-type: none"> 1. Replace defective parts.

RECEIVER TROUBLESHOOTING CHART

In the following chart, the symptom "no audio output" has been disregarded as being too general, since it would be caused by the failure of some stage or section as a secondary symptom. Therefore, this chart will show only the secondary symptoms.

SYMPTOM	POSSIBLE CAUSE	CURE
Low tuner sensitivity.	<ol style="list-style-type: none"> 1. Coaxial cables from the antenna jack to the receiver are shorted. 2. Defective tuner. 3. T-R network component failure. 4. Zener diode D312 connected in reverse. 	<ol style="list-style-type: none"> 1. Check for short circuits with an ohm and replace the cable if it is defective. 2. Connect the positive lead of a milliammeter to the free ends of resistor R317 and D312, and connect the common lead to the +A terminal on the tuner foil. If the current exceeds 10 mA, replace transistor Q1. Unless you have the capability of removing the tuner from its foil, this should be done in a factory. 3. Refer to T-R Switch Symptom on Trantone Troubleshooting Chart. 4. Reverse D312.
Crystal oscillator inoperative.	<ol style="list-style-type: none"> 1. Coil L7 improperly tuned. 2. Transistor defective or not installed properly. 3. Defective crystal. 	<ol style="list-style-type: none"> 1. Tune L7 for maximum signal on a general coverage Receiver. 2. Be sure transistor is installed properly. Replace if it is defective. 3. Replace crystal. <p>NOTE: You can check the crystal oscillator by tuning a general coverage receiver to the crystal frequency. If a strong signal is heard, the crystal oscillator is operating properly.</p>
Voltage reading low at collector of Q4.	<ol style="list-style-type: none"> 1. Primary of Transformer T2 open (check with ohmmeter for open circuit). 2. Capacitor C205 shorted. 3. Resistor R205 open. 	<ol style="list-style-type: none"> 1. Replace T2 (#52-116). 2. Replace capacitor C205. 3. Replace resistor R205.
Low voltage at base of Q6.	<ol style="list-style-type: none"> 1. Secondary of Transformer T2 open (check with ohmmeter for open circuit). 2. Capacitor C209 shorted. 3. R209, R218, or R219 wrong values. 	<ol style="list-style-type: none"> 1. Replace T2. 2. Replace C209. 3. Replace incorrect resistor.
Q6 emitter voltage zero	<ol style="list-style-type: none"> 1. Capacitor C212 shorted. 	<ol style="list-style-type: none"> 1. Replace C212.

SYMPTOM	POSSIBLE CAUSE	CURE
Q6 collector voltage zero.	<ol style="list-style-type: none"> Transformer T3 primary open (check with ohmmeter for open circuit). Capacitor C213 shorted. 	<ol style="list-style-type: none"> Replace T3. Replace C213.
No gain at Q6. Voltage at emitter high.	<ol style="list-style-type: none"> Resistor R211 open. 	<ol style="list-style-type: none"> Replace R211.
No gain at Q6.	<ol style="list-style-type: none"> Defective transistor. Measure base to emitter voltage. Base voltage should be .5 to .7 VDC higher than the emitter. 	<ol style="list-style-type: none"> Replace Q6.
No base voltage at Q7.	<ol style="list-style-type: none"> Open secondary winding in Transformer T3. Capacitor C214 shorted. 	<ol style="list-style-type: none"> Replace T3. Replace C214.
Low Gain at Q7.	<ol style="list-style-type: none"> Defective resistor R214 or R215 or wrong value installed. 	<ol style="list-style-type: none"> Check resistors R214 and R215.
No gain at Q7.	<ol style="list-style-type: none"> Resistor R216 open. Capacitor C215 open. 	<ol style="list-style-type: none"> Replace R216. Replace C215.
Zero voltage at collector of Q7.	<ol style="list-style-type: none"> Primary of Transformer T4 open. Resistor R217 open. 	<ol style="list-style-type: none"> Replace T4. Replace R217.
Detector not working.	<ol style="list-style-type: none"> Secondary of Transformer T4 open. Diode D201 open. A high voltage at the anode of D201 (proper voltage at the anode is approximately .6 VDC). No voltage at anode of diode D201. Resistor R218 or R219 open. 	<ol style="list-style-type: none"> Replace T4. Replace D201. Replace defective resistor.
Noise Limiter not operating.	<ol style="list-style-type: none"> Open diode D202. (If this diode is open, there will be .5 VDC at terminal 4 of the Noise Limiter switch when it is pushed in. Normal voltage is 1.9 VDC). Zero voltage at terminal 5 of Noise Limiter switch. Also no audio output present. 	<ol style="list-style-type: none"> Replace D202. Replace capacitor C219.

AUDIO TROUBLESHOOTING CHART

AUDIO SYMPTOMS	POSSIBLE CAUSE	CURE
Low audio output, audio control sounds scratchy.	<ol style="list-style-type: none"> 1. Capacitor C221 or C222 shorted. If C222 is shorted, varying of the Volume Control will vary the voltage at the base of Q8. 	<ol style="list-style-type: none"> 1. Replace C221 or C222.
Audio pre-amplifier Q8 does not amplify.	<ol style="list-style-type: none"> 1. Diode D203 shorted. When shorted, this diode will cause a decrease in voltage at the emitter of Q8 from a normal 2.6 VDC unquelled to .8 VDC. 2. Improper bias at base of Q8. Resistors R223 and R224 may be of improper value. 3. Zero volts at the emitter of Q8. 	<ol style="list-style-type: none"> 1. Replace D203. 2. Replace defective or improperly value components. 3. Replace capacitor C223.
Squelch control does not operate properly.	<ol style="list-style-type: none"> 1. Squelch control open. 2. Resistor R309 not properly connected from terminal 1 of the squelch control to the ground lug. R309 not the correct value. 3. The collector voltage at Q9 does not vary with the squelch control from approximately .8 VDC to 10 VDC. 4. Transistor Q10 open. (+10 VDC at the collector.) 	<ol style="list-style-type: none"> 1. Replace Squelch control. C227 shorted. 2. Replace or properly connect R309. 3. Replace Q9. 4. Replace Q10.
No output from audio preamplifier.	<ol style="list-style-type: none"> 1. Defective components: Q8, Q10, diode D203, and capacitor C223, D204. 	<ol style="list-style-type: none"> 1. Replace Q8, Q10, D203, D204, and C223.
A squeal in the audio or a loud hiss in the speaker when the receiver audio is turned down.	<ol style="list-style-type: none"> 1. Lug 1 on microphone switch improperly grounded. 2. RFC #5 open. 	<ol style="list-style-type: none"> 1. Reaccomplish the grounding of lug #1 of microphone switch. 2. Replace RFC #5.
Voltage at pin P of the Circuit Board is above 10 VDC.	<ol style="list-style-type: none"> 1. Diode D205 open. 	<ol style="list-style-type: none"> 1. Replace D205.

AUDIO SYMPTOMS	POSSIBLE CAUSE	CURE
No modulation, but receiver audio is present.	<ol style="list-style-type: none"> 1. Capacitor C327 shorted. 2. Capacitor C229 open (if there is no indication of audio at the base of Q12). 3. Capacitor C236 open. 	<ol style="list-style-type: none"> 1. Replace C327. 2. Replace C229. 3. Unsolder the positive lead of C236. Connect a signal generator to this lead and, if C236 is good, you will hear audio from the speaker. The same test can be made with capacitors C229 and C224.
No base or collector voltage at Q11 or Q12.	<ol style="list-style-type: none"> 1. Capacitor C232 shorted. 2. Resistor R239 open. 	<ol style="list-style-type: none"> 1. Replace C332. 2. Replace R239.
Hum coming from the mic amplifier stages.	<ol style="list-style-type: none"> 1. Capacitor C232 open. 	<ol style="list-style-type: none"> 1. Remove capacitor C232. If there is a difference in hum level, replace C232.
Hum in the driver of the modulator.	<ol style="list-style-type: none"> 1. Capacitor C238 open. 	<ol style="list-style-type: none"> 1. Replace capacitor C238.
Over 2 VDC at pin G (collector) of Q13.	<ol style="list-style-type: none"> 1. Open primary winding of Transformer T5. 	<ol style="list-style-type: none"> 1. If an ohmmeter confirms an open circuit, replace T5.
No voltage at the base or emitter of Q13.	<ol style="list-style-type: none"> 1. Resistor R245 open. 	<ol style="list-style-type: none"> 1. Replace R245.
Cannot adjust bias on Q14 and Q15.	<ol style="list-style-type: none"> 1. Resistor R246 or R247 open. 	<ol style="list-style-type: none"> 1. Check with an ohmmeter and replace the defective resistor.
An arcing sound in the modulation transformer when transmitting.	<ol style="list-style-type: none"> 1. RF feedback. 	<ol style="list-style-type: none"> 1. Interchange the green and yellow leads from T5 at the bases of Q14 and Q15.
Modulation with no receiver audio.	<ol style="list-style-type: none"> 1. Phone jack shorting terminals are open. 2. Speaker open. 3. The internal switch on the microphone is not shorting to ground the black-yellow wire of the speaker winding on the modulation transformer. 	<ol style="list-style-type: none"> 1. Bend the shorting terminals just enough for them to make a connection with no plug in the jack. 2. Replace the speaker. 3. Check the grounding function of the Microphone switch in the Receive mode. Replace the switch, if necessary.

CIRCUIT DESCRIPTION

The Circuit Description is provided to give both the novice and the experienced kit builder a better understanding of what is happening in each stage of the Transceiver. Refer to the Block Diagram and the Schematic Diagram when reading the Circuit Description. For your convenience, a partial schematic diagram is also presented for each portion of the circuit as it is discussed.

The Block Diagram outlines the relationship between circuits. On it, two groups of circuits are contained within dashed-line boxes. One box encloses the receiver circuits and the other box encloses the transmitter circuits. Other circuits shown are common to both receive and transmit functions.

Letter number designations for the resistors, capacitors, and diodes are placed in the following groups. This grouping will make it easier to locate parts on the Schematic and on the chassis.

- 0- 99 Parts mounted in preassembled tuner.
- 100-199 Parts mounted on transmitter circuit board.
- 200-299 Parts mounted on receiver circuit board.
- 300-399 Parts mounted elsewhere.

The receiver portion of the Transceiver employs 13 transistors and five diodes in a double-conversion, superheterodyne circuit. The audio driver and amplifier stages are also used as a driver and modulator when the transmitter section is energized. The circuit consists of: a broad-band, neutralized RF amplifier; a low-noise mixer with a high frequency, tunable oscillator for frequency conversion; a high frequency crystal-controlled IF stage; and two low frequency IF stages, AGC, ANL, Squelch, and relative signal strength metering circuits are also incorporated in the receiver design.

The transmitter section employs three tubes in a circuit providing AM output. The pentode portion of a triode-pentode functions as a modified Pierce oscillator, or may be used as a straight-through amplifier for an accessory VFO. The plate circuit of this stage is tuned to the third harmonic of the control grid frequency. The triode section of this tube acts as a second frequency tripler. A pentode tube acts as a driver-doubler, and the final tube is a compactron tube operated as a class C amplifier with both screen and plate modulated. Link coupling is used from the plate circuit to the antenna.

TRANSMITTER CIRCUITS

OSCILLATOR-TRIPLER V1A (Figure 6-1)

Tube V1A is a pentode that is operated as a modified Pierce crystal oscillator-tripler or as an amplifier-tripler. The plate circuit of this tube is tuned to three times the fundamental frequency of the grid circuit. Plate tuning is accomplished by coil L8 and variable capacitor C301A, which is one section of three-section variable capacitor C301.

Up to four crystals may be installed inside the Transceiver. Three of the crystal holders are of the FT-243 type, and one is a HC-6U type. When the XTAL-VFO switch is in one of the crystal positions, the crystal is connected between the control grid and the screen grid of oscillator-tripler V1A. Capacitor C305 is in series with the screen side of the crystal and acts as a DC blocking capacitor.

When tube V1A operates as an oscillator-tripler, its frequency is crystal controlled. When the tube operates as an amplifier-tripler, its frequency is controlled by an external VFO. The XTAL-VFO switch on the front panel of the Transceiver selects one of four crystals, or an external VFO (if used). The fundamental frequency of the crystal and VFO must be in the same frequency range, 7.956 to 8.233 MHz.

The output of an external VFO may be connected through the VFO INPUT jack to lug 5 of XTAL-VFO switch SW4A. When this switch is in the VFO position, the output of the VFO is connected to the control grid of tube V1A, which acts as an amplifier-tripler. SW4B turns on the oscillator tube in the external VFO by completing its cathode circuit through lugs 6 and 8 of the switch.

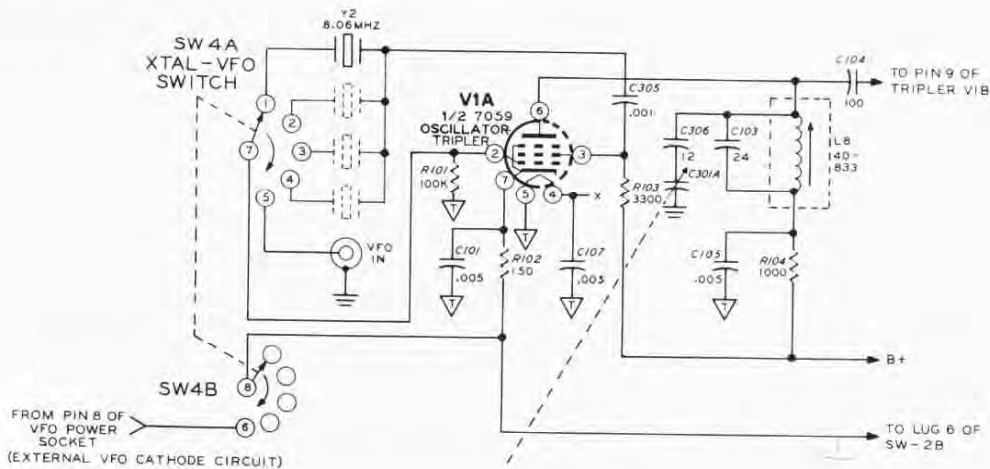

OSCILLATOR AND TRIPLER TUBE V1A

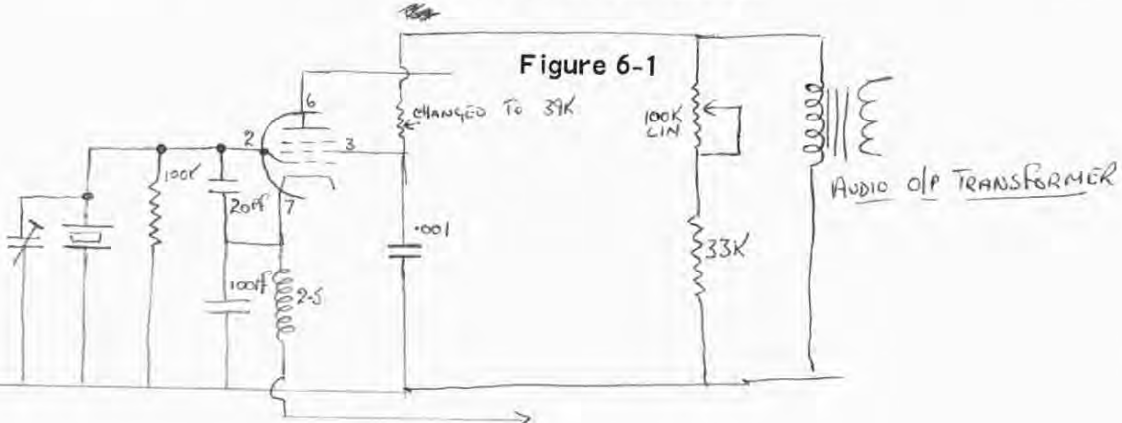

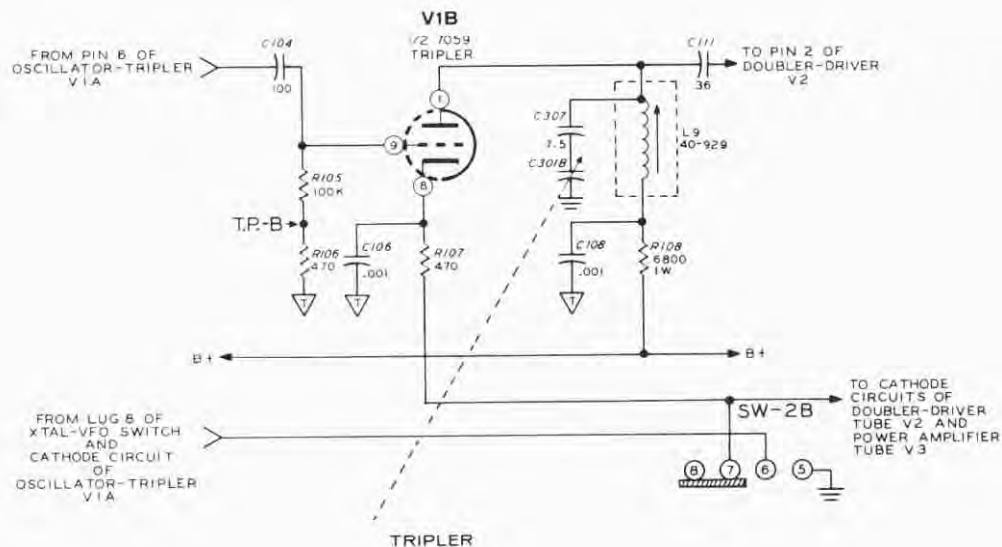

Figure 6-2

TRIPLER (Figure 6-2)

The output of tube V1A is coupled through capacitor C104 to the control grid of tube V1B, which operates as a frequency tripler. The plate circuit is tuned to three times the frequency of its grid circuit by coil L9 and variable capacitor C301B. The tripled frequency is then coupled through capacitor C111 to doubler-driver tube V2.

The cathode circuit of V1B is connected to lug 6 of Function Switch SW-2B. When this switch is

in the Rcvr Trans position, the cathode circuits of an external VFO (if one is being used) and oscillator-tripler tube V1A are connected to the remaining transmitter cathode circuits, which are grounded when the microphone button is pressed. When the switch is in the Spot position, tube V1A is turned on by the grounding of its cathode circuit. Tubes V1B, V2 and V3 remain inoperative, but the entire Receiver is operating. This permits reception of the crystal harmonics and identification of the output frequency on the Receiver dial.

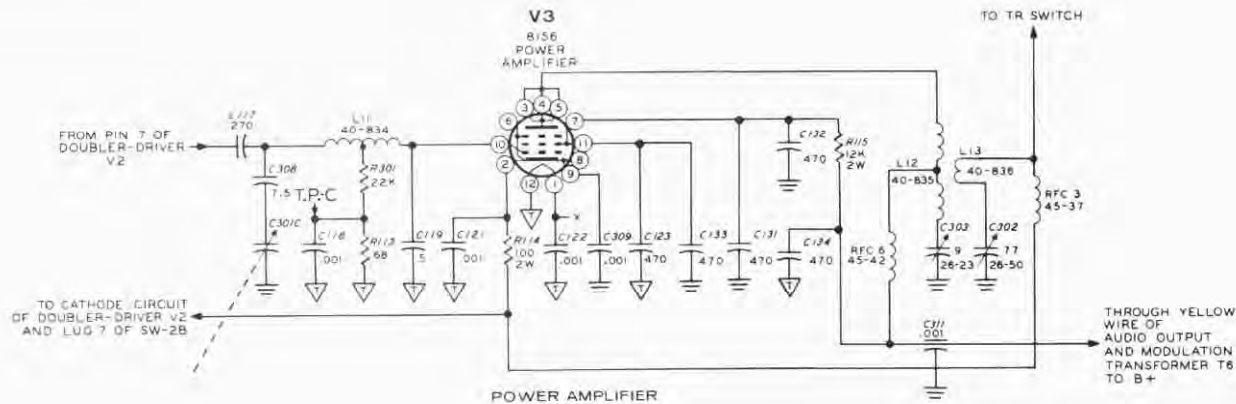

Figure 6-4

POWER AMPLIFIER (Figure 6-4)

The output of tube V2 is coupled to power amplifier tube V3 by coupling capacitor C117 and an impedance-matching pi network that consists of capacitors C308, C301C, C119, and coil L11. Capacitor C301C is used to tune the doubler-driver output to the desired frequency.

The type 8156 power amplifier tube is a beam power pentode. This 12-pin compactron tube operates as a class C amplifier. Resistor R114 provides self-bias to protect the tube against loss of drive. The screen grid and plate are

modulated by the B+ voltage which is routed through a secondary winding of audio output and modulation transformer T6. The power input is 25 to 30 watts, permitting a modulated RF carrier output of 8 to 10 watts.

The plate circuit is tuned for maximum output by the series circuit of coil L12 and variable capacitor C303. The modulated RF output of the power amplifier is inductively coupled to link coil L13. Variable capacitor C302 connects between L13 and ground to tune out any reactance present. The modulated output from L13 is fed to the input of the TR switch circuit (D101 and associated circuitry).

RECEIVER CIRCUITS

PREASSEMBLED TUNER (Figure 6-5)

RF amplifier transistor Q1 is a silicon N-channel, junction FET (field-effect-transistor) type that operates in a broad-band RF circuit. This circuit arrangement offers improved characteristics for low noise, low cross-modulation, and higher amplification than is found in conventional transistor circuits. The RF amplifier stage is neutralized by capacitor C1 and coil L2 for optimum signal-to-noise ratio.

The RF signal from the antenna goes through the TR switching circuit and is coupled to coil L1 in the tuner by capacitor C314. Coil L1 couples the RF signal to the gate of Q1. AGC (automatic gain control) is applied through coil L1 to the gate (G) of Q1 to control its gain and prevent it from being overdriven by strong signals.

The amplified signal from the drain (D) of Q1 is connected to the mixer, Q2, through an over-coupled, double-tuned circuit consisting of capacitor C5, coil L3, resistor R2, coil L4, and

capacitor C7. This circuit is used in the output of Q1 to achieve the desired bandpass characteristics over the 5 MHz range of the Transceiver. This circuit presents a high impedance to the RF amplifier output at the signal frequency, but attenuates other frequencies.

The high frequency variable oscillator circuit of transistor Q3 tunes a frequency range from 118,235 MHz to 123,235 MHz. The oscillator frequency is always 24.965 MHz lower than the RF signal frequency from the antenna, Q3 is connected in a common-emitter configuration with the frequency-determining component connected between the collector and emitter, and collector to ground. Variable capacitor C18 is the main tuning capacitor for the receiver, and trimmer capacitor C16 provides for fine frequency adjustments. The output of the variable oscillator is coupled through capacitor C8 to the source of transistor Q2.

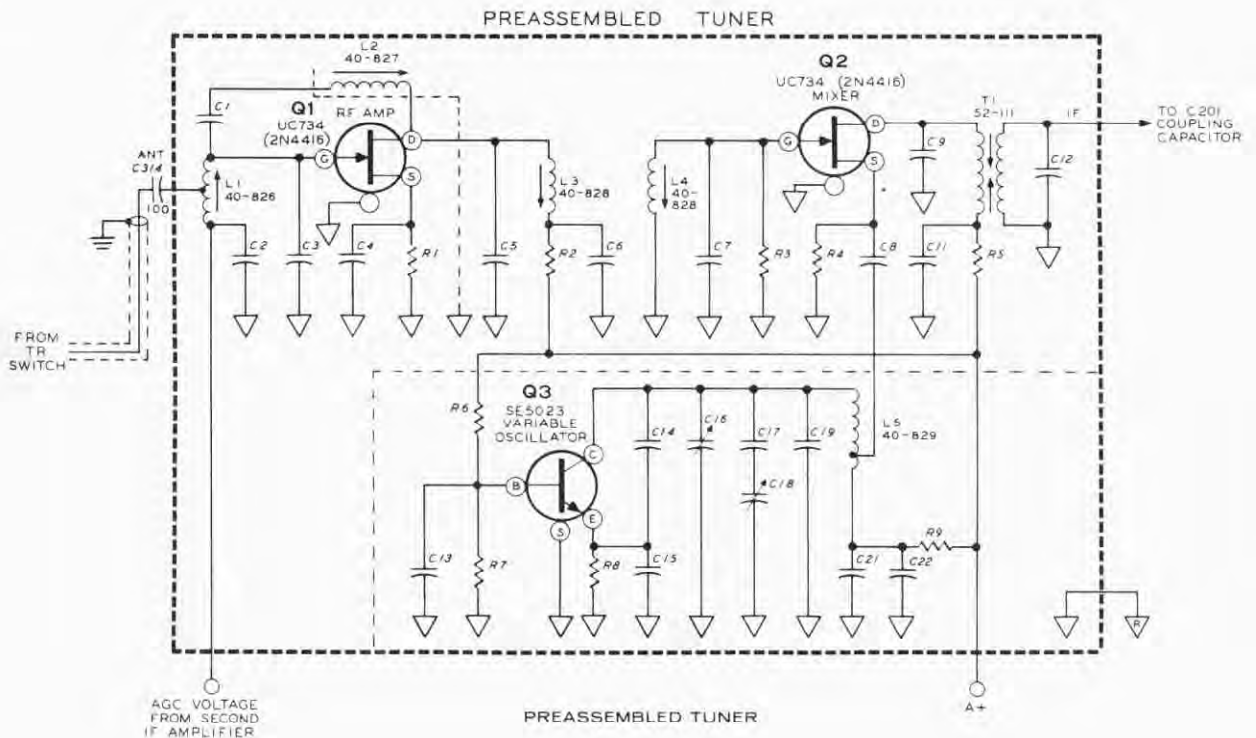

Figure 6-5

Q2, the first mixer, is also an N-channel FET. This stage mixes the output from the high frequency oscillator with the incoming signal, to provide sum and difference frequencies. The output from the drain of mixer Q2 is connected to the primary winding of transformer T1, which is tuned to the difference frequency of 24,965 MHz and appears as a high impedance to the output of Q2 at that frequency. The secondary winding of the transformer is connected to coupling capacitor C201 which is outside the preassembled tuner.

OSCILLATOR AND MIXER (Figure 6-7)

The output from the secondary winding of transformer T1 is coupled by capacitor C201 to the primary winding of coil L6. Transformer T1 and capacitor C12 in the tuner combine with C201, C202, and coil L6 to form a three element, pi section filter which appears as a high impedance to the 24,965 MHz tuner output frequency and acts as a bandpass filter.

The secondary winding of coil L6 is connected to the base of second mixer transistor Q4. The 24,965 MHz signal from the bandpass filter is mixed with a 26,965 MHz signal from crystal oscillator transistor Q5 to produce a 2 MHz intermediate frequency.

Transistor Q5 is connected as a crystal-controlled Pierce oscillator. The oscillator's 26,695 MHz output frequency is coupled to the emitter of mixer transistor Q4 by coil L7, resistor R204, and capacitor C204. Coil L7 is tuned to 26,695 MHz to peak the oscillator signal output. The value of capacitor C204 has been selected to provide the proper amount of oscillator injection to the mixer for optimum conversion gain.

From the collector of mixer transistor Q4, the output signal frequency is connected to the tap on the primary winding of transformer T2, which is tuned to the 2 MHz intermediate frequency. The secondary winding of the transformer is connected to the base of IF amplifier transistor Q6.

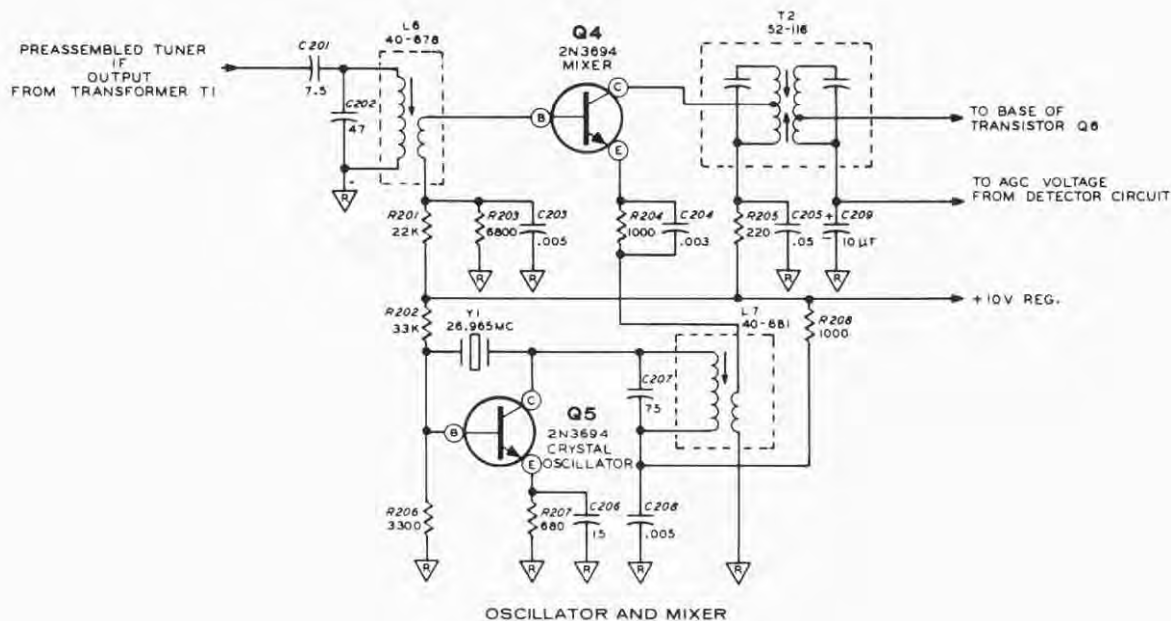

Figure 6-6

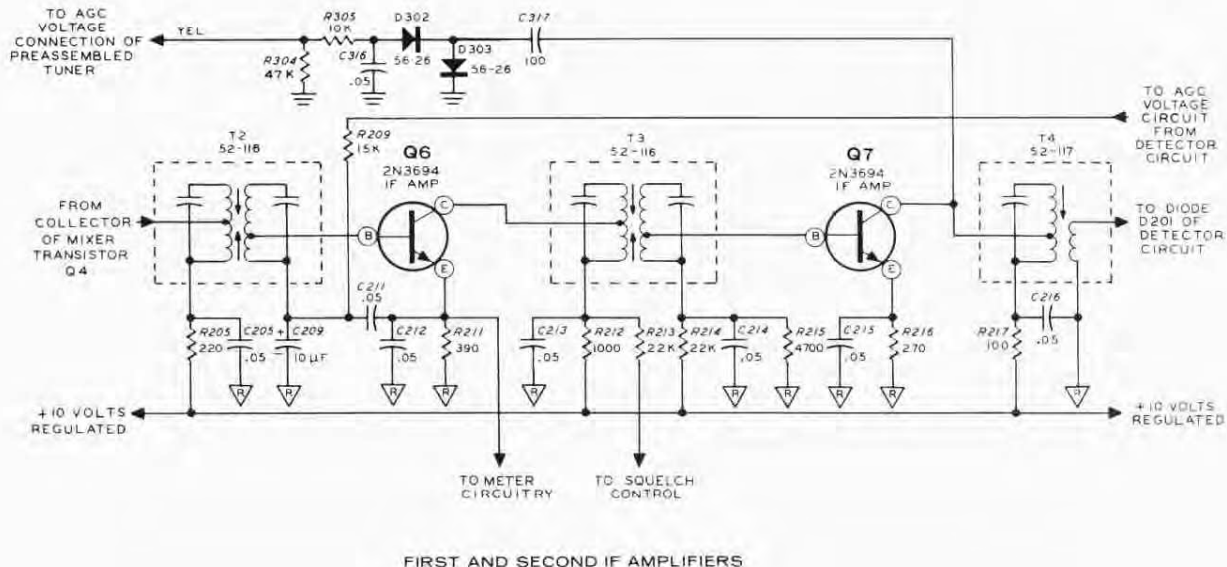

Figure 6-7

FIRST AND SECOND IF AMPLIFIERS (Figure 6-7)

A tap on the secondary winding of transformer T2 is connected to the base of IF amplifier transistor Q6. AGC voltage from the detector circuit is also connected to the base of Q6 through decoupling resistor R209 and the tapped secondary winding of transformer T2. The output from the collector of Q6 is connected through IF transformer T3 to the base of IF amplifier transistor Q7. The output from its collector is connected through transformer T4 to the detector circuit.

The primary winding of IF transformer T3 is connected to the squelch circuitry, which oper-

ates from the voltage developed across resistor R212 in the collector circuit of the transistor.

The collector of IF amplifier transistor Q7 is used in developing an AGC voltage for the pre-assembled tuner. Capacitor C317 is connected to the collector of the transistor and, when strong signals are present at the collector, couples a small RF voltage to voltage rectifier and doubler diodes D302 and D303. The output of the diodes is a negative-going voltage that is filtered by capacitor C316, and resistors R304 and R305. The filtered negative voltage is applied to the gate of transistor Q1 to reduce the gain in the presence of strong RF signals.

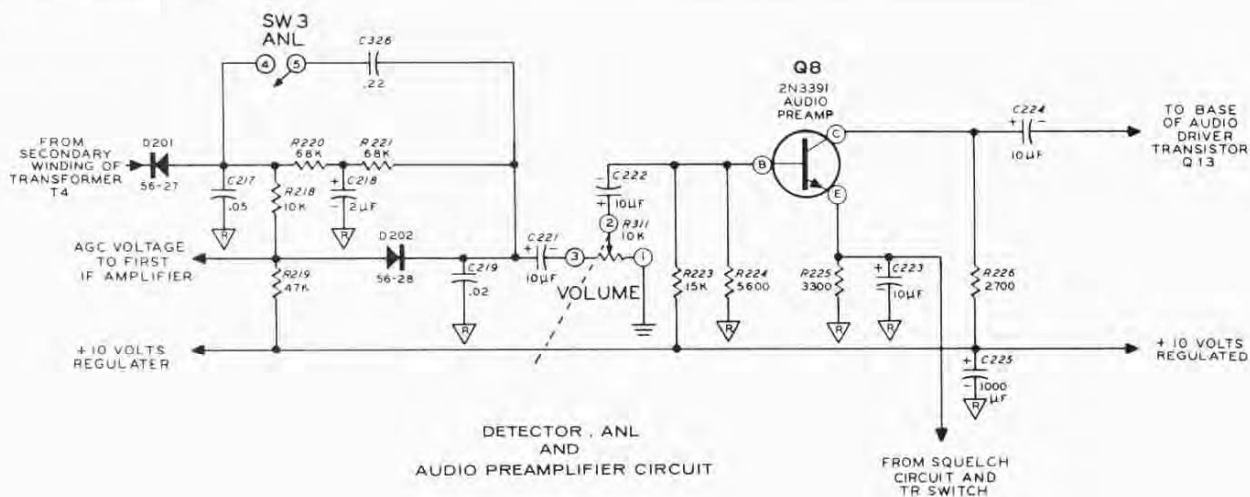

Figure 6-8

DETECTOR-ANL-AND AUDIO PREAMPLIFIER CIRCUITS (Figure 6-8)

The secondary of transformer T4 is connected to diode D201, which detects the audio signal from the IF amplifiers. The detected audio signal is connected to the volume control through two different paths, depending upon the position of the ANL (automatic noise limiter) switch.

When the ANL switch is in the closed position, the audio signal is routed through capacitor C326 to capacitor C221, which is connected to the volume control. When the ANL switch is in the open position, the audio signal is routed through the automatic noise limiter circuitry instead of capacitor C326 and the ANL switch.

The detected audio signal is prevented from flowing through resistors R220 and R221 to the Volume control because these two resistors, along with capacitor C218, form an audio filter that stops the audio signal but allows a small DC voltage to pass through. The small DC voltage biases the cathode of diode D202.

The audio signal then passes through resistor R218, diode D202, and capacitor C221 to the Volume control. The diode clips the peaks of the audio signal, limiting noise spikes.

Resistors R218 and R219 also form a voltage divider network from which a DC voltage is taken and applied through resistor R209 to the base return of the first IF amplifier as an AGC voltage. This AGC voltage is filtered by capacitor C209.

Capacitor C222 couples the audio signal from the volume control to the base of audio preamplifier transistor Q8. The signal is amplified by the transistor and coupled through capacitor C224 to the base of audio driver transistor Q13.

The emitter of audio preamplifier transistor Q8 is connected to the squelch and TR switching circuits. The squelch circuit cuts off the audio output from Q8 when no signal is being received at the antenna or when the signal level is below the threshold level set by the squelch control. The TR switching circuit cuts off the audio output from Q8 when the microphone button is pressed. The operation of the squelch circuit and TR switching circuit will be described later.

The input circuit of microphone preamplifier Q11 is designed to match the microphone supplied. RFC 5 and capacitor C228 are included to reject and bypass any RF energy picked up by the microphone circuitry. D314 removes any remaining RF in the collector circuit of Q8.

The microphone output signal is amplified by Q11, and is coupled through capacitor C229 to microphone amplifier Q12. Q12 again amplifies the signal, which is then coupled by capacitor C236 to audio driver Q13. The reactance of capacitor C235 attenuates audio signals above 3500 Hz, thereby helping to reduce the splatter of higher frequencies in the sidebands.

AUDIO DRIVER AND AUDIO OUTPUT
(Figure 6-10)

The audio signals coupled to audio driver transistor Q13 originate from audio preamplifier transistor Q8 or microphone amplifier transistor Q12. During the receive mode of operation, the audio signal is coupled from Q8 through C224 to Q13, and the microphone input is grounded. During the transmit mode of operation, the signal from Q12 is coupled through capacitor C236 to Q13.

Q13 amplifies the audio signal and transformer T5 couples it to the class B push-pull output amplifiers, Q14 and Q15.

Control R246 is adjusted to provide the proper bias to the audio output transistors. The amplified audio output signal from Q14 and Q15 is coupled by one output winding of transformer T6 to the 3.2 ohm speaker through the phones jack. The high voltage is fed to tube V3 through the other output winding of T6, which acts as the modulation transformer.

When the Transceiver is in the receive mode of operation, the speaker secondary winding is grounded through the microphone switch. Modulated high voltage is fed to V3 also, but it is not operating since its cathode is not grounded. When the Transceiver is in the transmit mode of operation, the speaker secondary winding is removed from ground, which cuts off the audio output. Modulated high voltage is still fed to the power amplifier tube by the other transformer secondary winding. Now the modulated high voltage is used to modulate the carrier frequency.

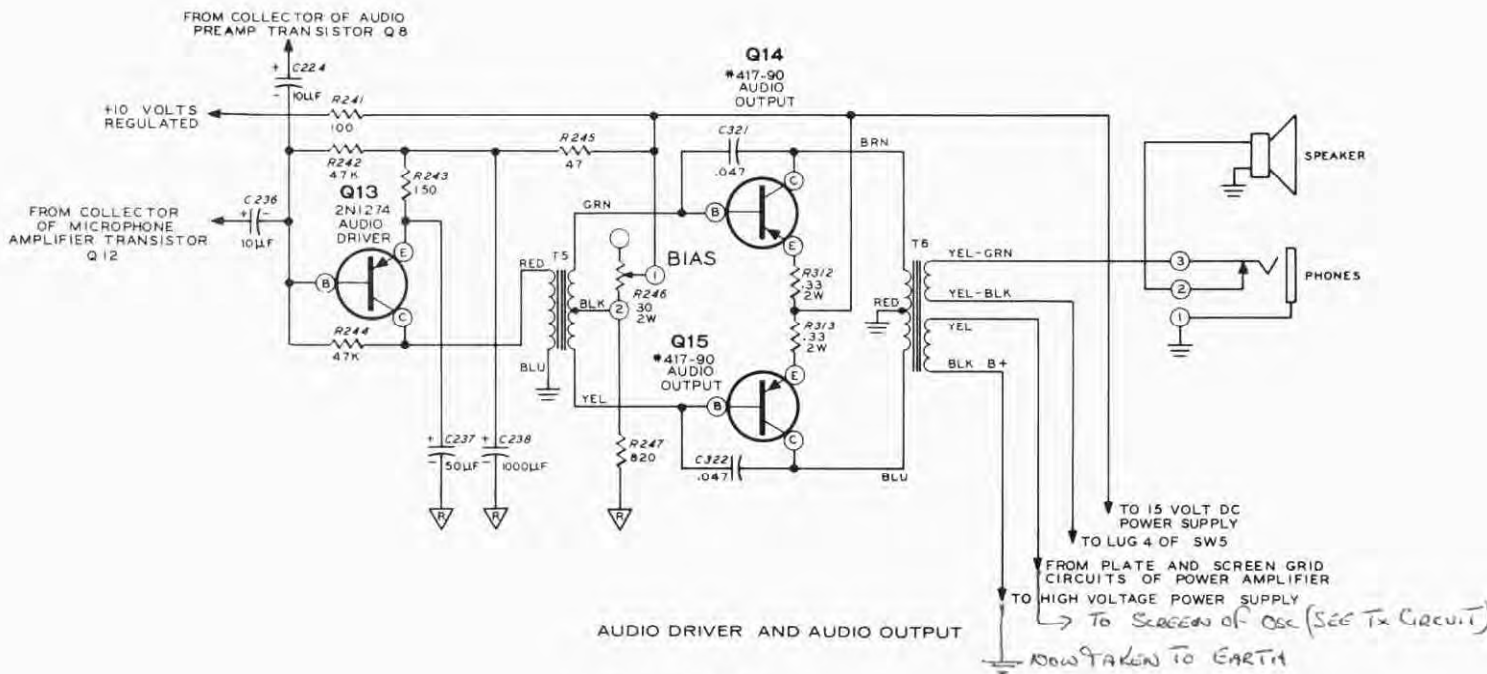

Figure 6-10

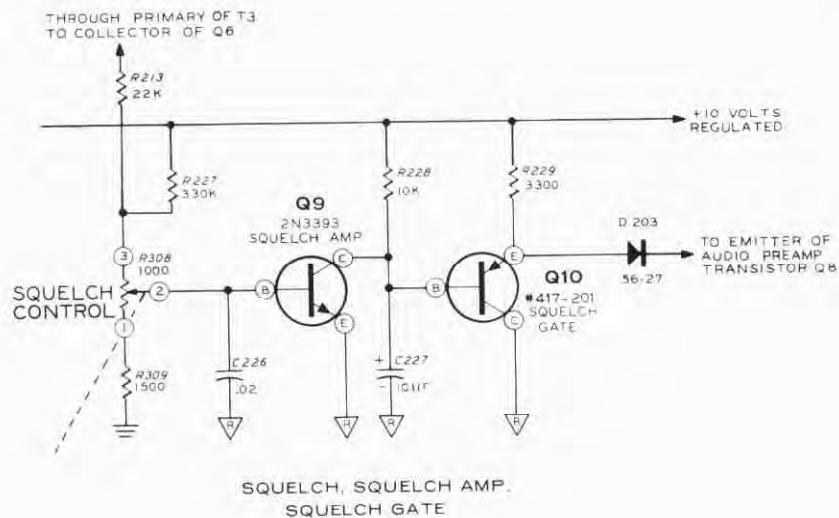

Figure 6-11

SQUELCH CIRCUIT (Figure 6-11)

Resistors R213 and R227 form a voltage divider in the collector circuit of IF amplifier transistor Q6. Control R308 forms a second voltage divider and controls the bias to the base of Q9, the squelch amplifier. This bias is adjusted under "no signal" conditions to less than .6 volts, which causes Q9 to stop conducting. The collector of Q9 is directly connected to the base of Q10, which is therefore cut off. This action causes diode D203 to conduct which, in turn, applies reverse bias to Q8, thus preventing it from amplifying.

When a signal is received, the bias voltage on Q9 rises above .6 volt and turns the stage on.

This causes Q10 to conduct, which drops the voltage on the anode of D203 and permits Q8 to conduct.

This circuit may be adjusted to render the audio section of the receiver inoperative until the AGC circuit is activated, thus giving complete quieting of the receiver noise commonly associated with VHF reception.

The squelch circuit is very desirable in mobile or network operation, for the absence of constant receiver noise can be of material aid in avoiding operator fatigue.

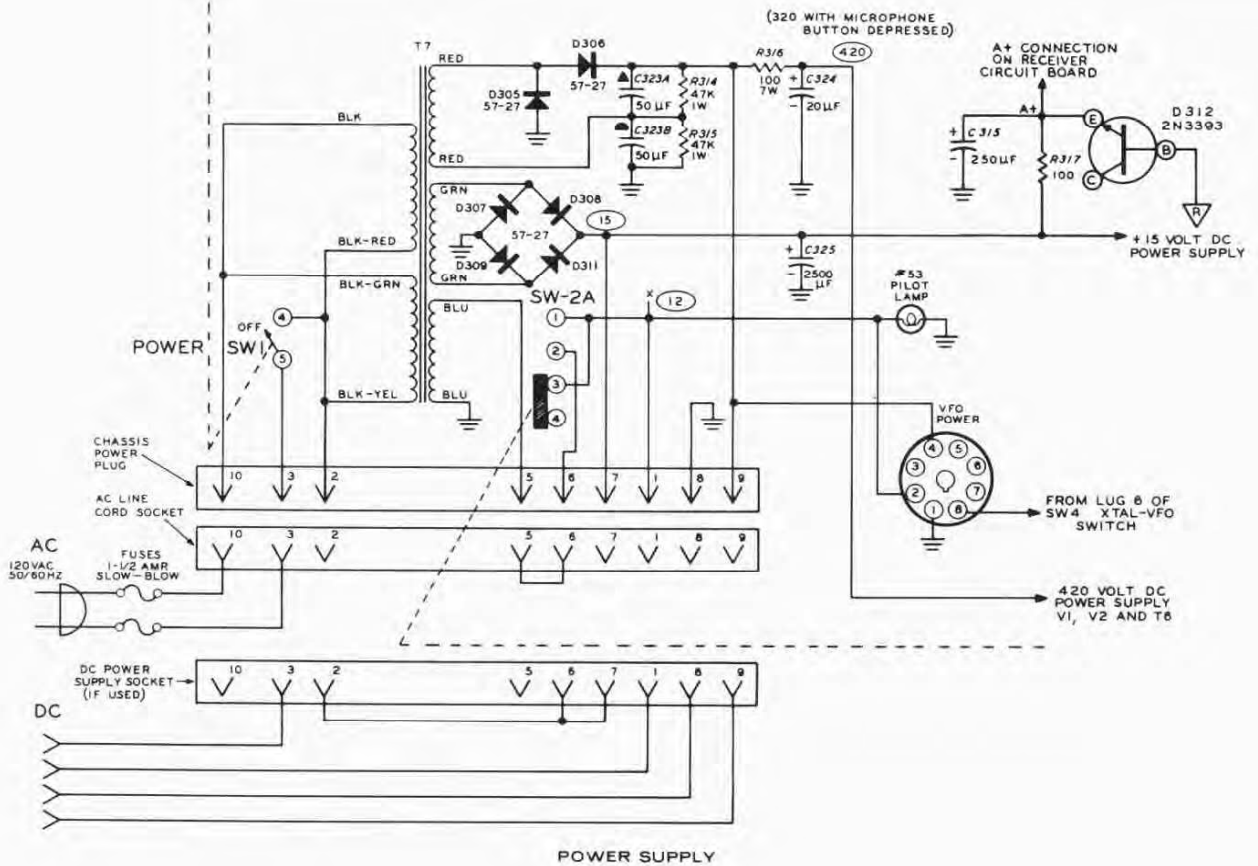

Figure 6-14

Resistor R317 is part of a voltage regulator network composed of electrolytic capacitor C315 and transistor D312. This transistor has the collector lead clipped off and operates as a zener diode to regulate the tuner voltage.

The 12 volt secondary winding of T7 furnishes 12 volts AC through Function switch SW-2A and the Power plug to the transmitter tube filaments, pilot lamp, and VFO Power socket. This winding is connected through lugs 5 and 6 of the Power plug so that if an external power supply is used, the winding is bypassed and 12 volts DC is fed directly to the transmitter tube filaments, pilot lamp, and VFO Power socket.

Function switch SW-2A disconnects power from the tube filaments, pilot lamp, and VFO Power

socket when it is in the BATT SAVER position. In the RCVR TRANS position, the Transceiver operates normally. When the switch is in the SPOT position, the power supply is not affected.

When the Transceiver is used in mobile applications, the cable from the external DC power supply, Model HWA-17-1, is used in place of the AC line cord. The internal filtering circuits of the Transceiver are used with the external power supply. Power transformer T7 is electrically bypassed since it is not required in this application.

NOTE: When a DC power supply is used, the voltage readings marked on Figure 6-14 will vary depending upon battery condition.

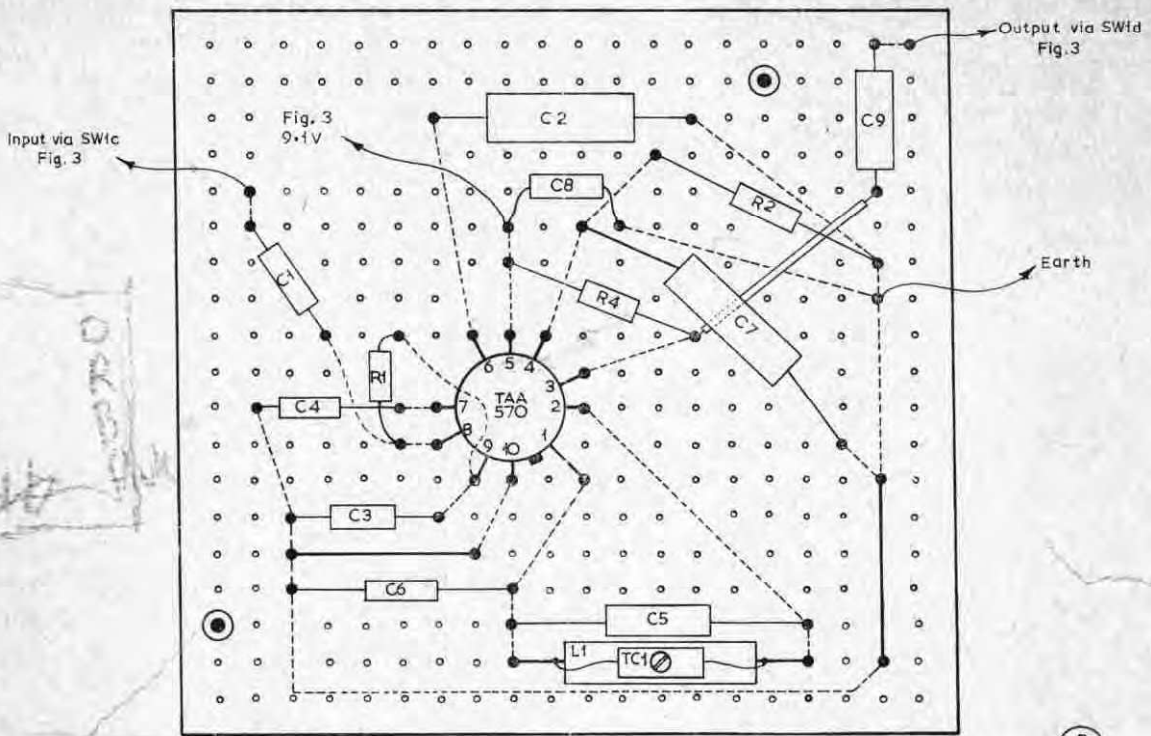

Fig. 2. Veroboard layout

R
610

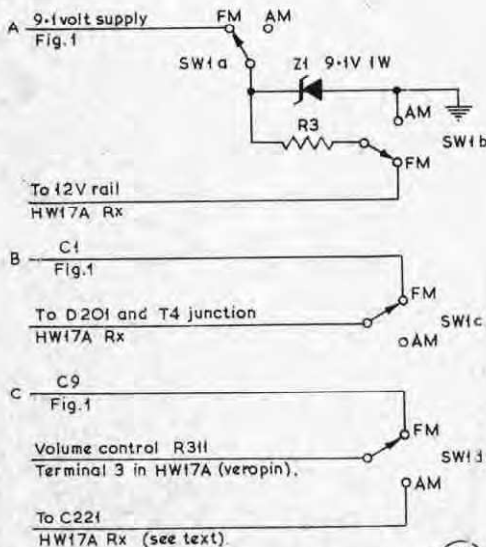

Fig. 3. AM to FM Switch Diagram

R
611

plate of the HW-17A, above the Rx board near the pins for the volume control, the coil L1 being at the bottom of the board. The 4-pole 2-way slide switch is mounted to the right (looking from the front) of the FM board, thus making any wiring very short; no screening was required. It was decided not to mount the switch on the front panel as a matter of convenience, but there is room for it if required on the front panel. This of course would require some of the leads to be screened.

Wiring the board and switch into the HW-17A receiver is a simple job. A wire from SW1 is taken to the *Vero pin* adjacent to diode D201, the other side of the switch to the IC board capacitor C1, terminal B. Connections for the output require the 10 μ F capacitor C221 negative wire in the Rx to be disconnected and a *Veropin* inserted; a wire from this is taken to the switch slider, a hole being drilled in the P.C. board, and a pin is inserted. C221 negative wire is connected and a lead to SW1 AM position; a wire is then taken from SW1 FM position to C9, terminal C on the IC board.

The wiring for the supply is self-explanatory, one pole being used for supplying the IC board, the other as a convenient means of connecting Z1 and R1. When the modifications have been completed and with the switch in the FM position a loud hiss will be heard from the speaker when switched on, but tuning into a carrier will cause the hiss to disappear completely. TC1 is

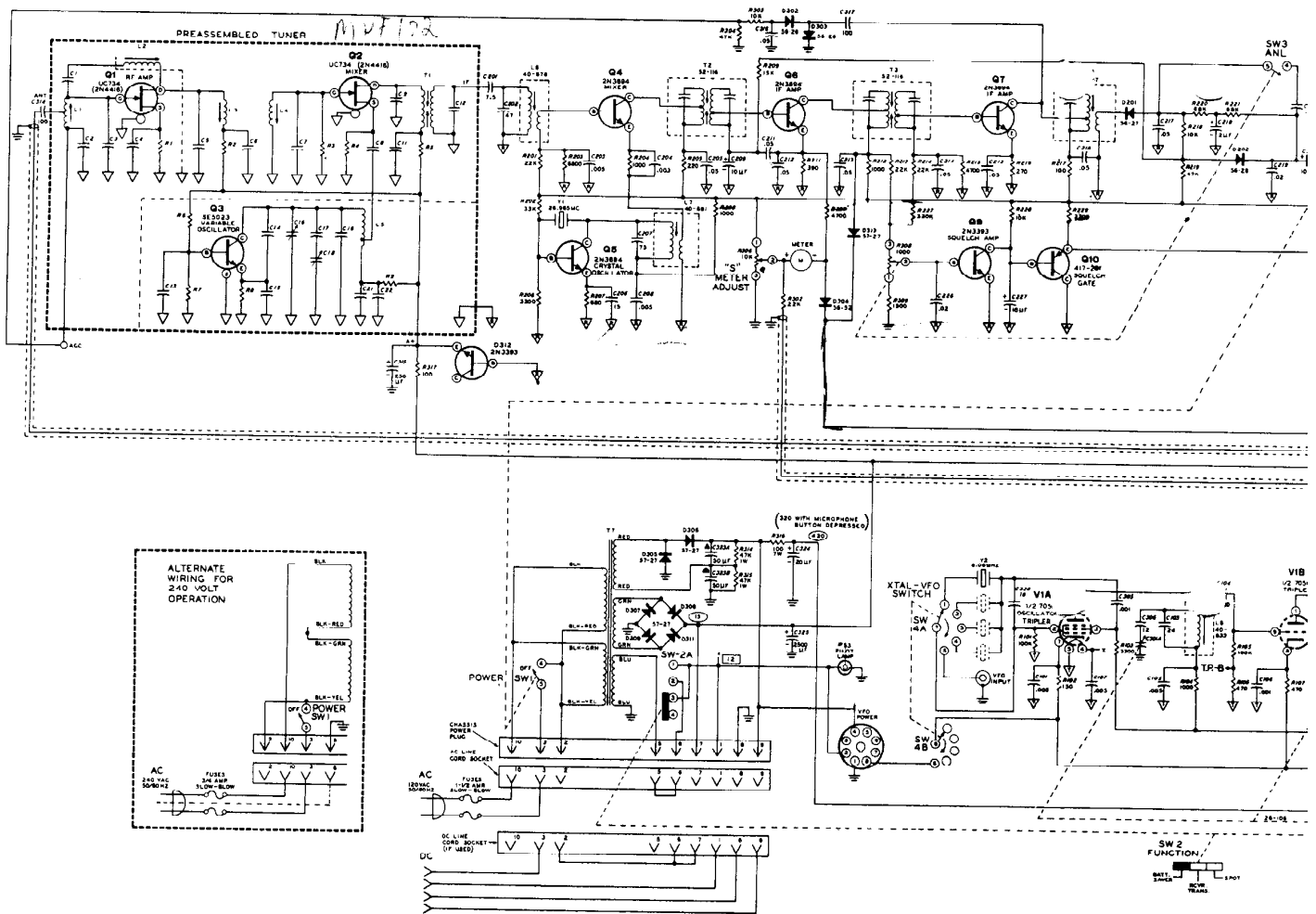

**SCHEMATIC OF THE
HEATHKIT®
TWO METER AM TRANSCEIVER
MODEL HW-17**

1. RESISTOR, CAPACITOR, AND DIODE NUMBERS ARE IN THE FOLLOWING GROUPS:

- 0-99 PARTS MOUNTED IN THE TUNER
- 100-199 PARTS MOUNTED ON THE TRANSMITTER CIRCUIT BOARD
- 200-299 PARTS MOUNTED ON THE RECEIVER CIRCUIT BOARD
- 300-399 PARTS MOUNTED ELSEWHERE

2. ALL RESISTORS ARE 1/2 WATT UNLESS MARKED OTHERWISE. RESISTOR VALUES ARE IN OHMS (K=1,000; M=1,000,000).

3. CAPACITOR VALUES LESS THAN 1 ARE IN μ F. VALUES OF 1 AND ABOVE ARE pF UNLESS THEY ARE MARKED OTHERWISE.

4. ARROW (\curvearrowright) INDICATES CLOCKWISE ROTATION OF SWITCH SHAFT (VIEWED FROM KNOB END).

5. SWITCHES ARE SHOWN IN THE FOLLOWING POSITIONS:
POWER SWITCH IN OFF.
FUNCTION SWITCH IN BATT. SAVER.
ANL SWITCH IN 'ON'.
MICROPHONE PTT SWITCH IN 'RECEIVE'.

6. \bigcirc THIS SYMBOL INDICATES A POSITIVE DC VOLTAGE MEASUREMENT, UNLESS MARKED OTHERWISE, TAKEN FROM THE POINT INDICATED TO CHASSIS GROUND WITH AN 11 MEGOHM INPUT VTVM. VOLTAGES MAY VARY $\pm 20\%$. \square THIS SYMBOL INDICATES AN AC VOLTAGE TAKEN FROM THE POINT INDICATED TO CHASSIS GROUND.

7. REFER TO CHASSIS PHOTOGRAPHS AND X-RAY VIEWS FOR THE PHYSICAL LOCATIONS OF PARTS.

8. POWER TRANSFORMER PRIMARY WIRING CONNECTIONS FOR 240 VAC ARE SHOWN IN THE BOX.

- 9. ∇ THIS SYMBOL INDICATES A COMMON CONNECTION INSIDE THE PREASSEMBLED TUNER.
- ∇ THIS SYMBOL INDICATES A CONNECTION TO THE RECEIVER CIRCUIT BOARD GROUND FOIL.
- ∇ THIS SYMBOL INDICATES A CONNECTION TO THE TRANSMITTER CIRCUIT BOARD GROUND FOIL.
- \equiv THIS SYMBOL INDICATES A CONNECTION TO THE CHASSIS.

NOTES:

- 1. ALL OTH VAL
- 2. ALL FAR
- 3. \bigcirc WITH VOL

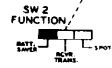
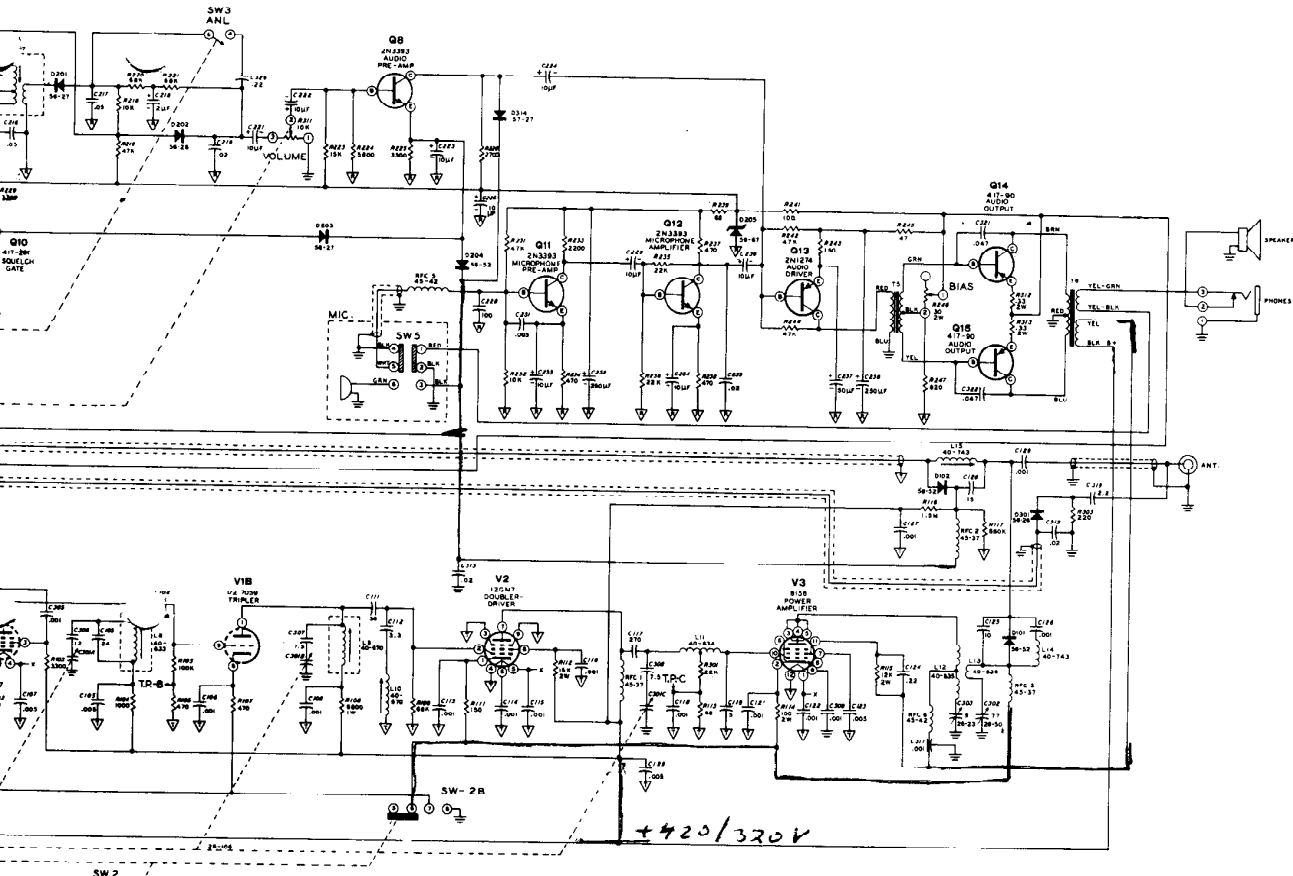

**SCHEMATIC OF THE
HEATHKIT®
MODEL HWA-17-1
TRANSISTORIZED DC
POWER SUPPLY**

- NOTES:
1. ALL RESISTORS ARE 1/2 WATT UNLESS OTHERWISE INDICATED. RESISTOR VALUES ARE IN OHMS (K=1000).
 2. ALL CAPACITOR VALUES ARE IN MICRO-FARADS (μF).
 3. ALL VOLTAGE READINGS WERE TAKEN WITH AN 11 MEGOHM INPUT VOLTMETER. VOLTAGES MAY VARY AS MUCH AS ±20%.

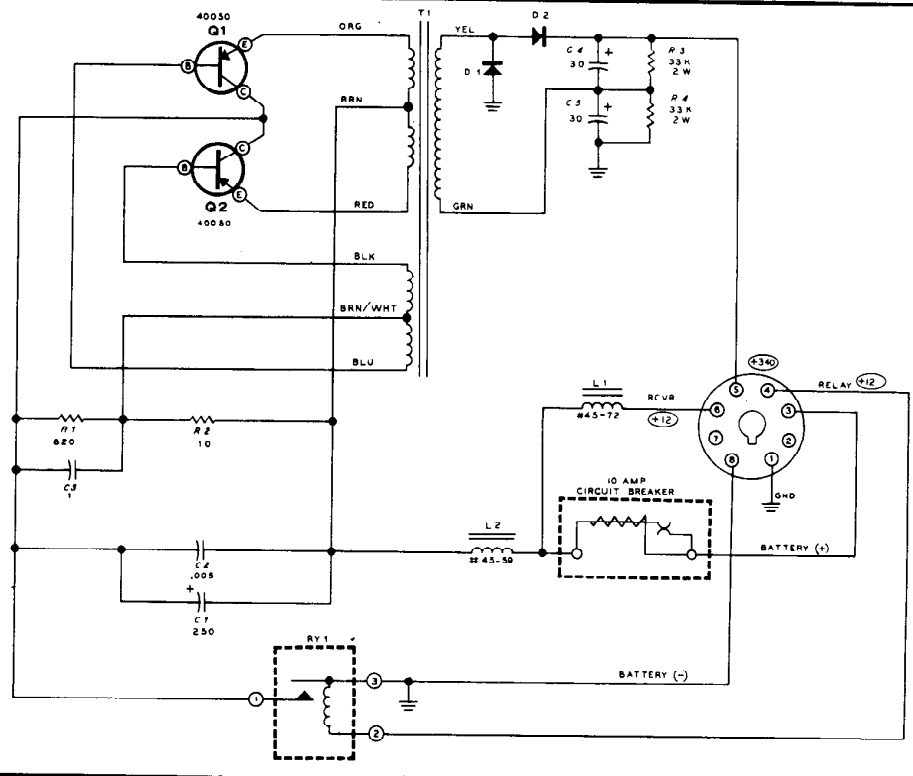

L787K



Two-Meter Transceiver and Mobile Power Supply

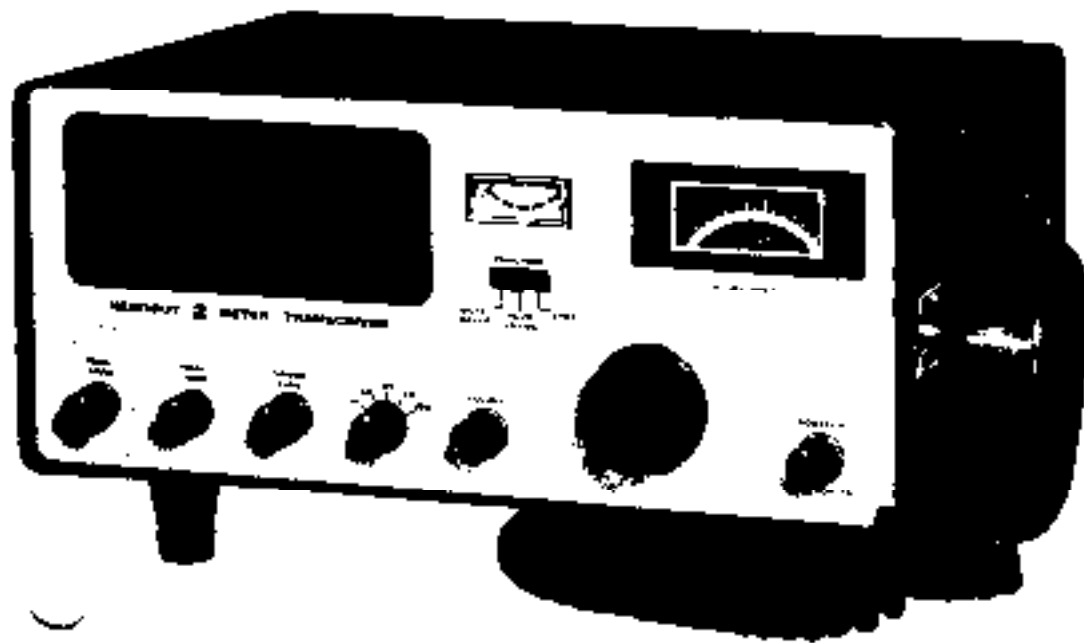

Representative for Norway
HAUER RADIO AS
Kongensgt. 27, N-0153
Tel. 022181110



HW17

Dependable, Rugged Mobile Operation . . . with the HWA-17-1 optional solid-state power supply. Goes together in just a few hours. Mount it almost anywhere in the car — 10 feet of connecting cable supplied. No modifications necessary to the HW-17 — just plug it in and you're ready to go.

Heathkit® 2-Meter AM Amateur Transceiver Kit and Optional Solid-State Mobile Power Supply Kit

The Heathkit HW-17 2-Meter AM Transceiver . . . the finest in value and performance for the VHF enthusiast.

Extended Coverage . . . transceives not only on the 2-meter ham band, but also capable of MARS, CAP and U. S. Coast Guard Auxiliary operation.

All Solid-State Receiver . . . the HW-17 receiver section is completely transistorized and employs 15 transistors in a high performance double conversion superheter circuit.

Relayless PTT Operation . . . switching done quickly — quietly by solid-state circuits.

Prebuilt, Prealigned Tuner . . . speeds assembly, minimizes construction errors. Incorporates an advanced design FET (Field Effect Transistor) circuit for low noise, low cross-modulation and higher amplification.

Crystal Controlled or VFO Transmit Option . . . one crystal supplied (145.08 MHz), sockets for three more of your choice. Or plug in the Heathkit HG-10 Series VFO (power and input jacks are provided on the rear apron of the HW-17).

Battery-Saver Switch . . . activates only the receiver section and draws just 100 mA — just the thing for mobile monitoring.

Fixed or Mobile . . . the HW-17 can be quickly switched from one type of operation to the other, thanks to the gimbal mounting bracket and separate power cables.

Built-In AC Power Supply . . . the HW-17 can be operated from either 120 v. or 240 v., 50-60 Hz sources depending on wiring option selected.

420/320V HT

High Sensitivity . . . receiver features 1 μ v sensitivity for 10 dB signal plus noise to noise ratio.

Dual AGC . . . Automatic Gain Control voltage is derived from both the audio and IF circuits to provide optimum reception of both DX and strong local signals.

Automatic Noise Limiter . . . the ANL is activated by pulling out the squelch control knob and effectively reduces interfering impulse noise.

"Spot" Function . . . helps to quickly determine transmitting frequency by activating the exciter stages of the transmitter.

Optimum Selectivity . . . selectivity of 27 kHz at the 6 dB points is most consistent with ease of tuning and band occupancy.

Squelch Circuit . . . sensitive squelch circuit eliminates background noise between transmissions.

High Output Per Dollar . . . the output of the transmitter is 8 to 10 watts; input to the final is 25 to 30 watts.

Less Sideband Splatter . . . modulating frequencies above 3500 Hz are attenuated to reduce the splatter of higher frequencies in the sidebands.

Short Construction Time . . . the 15 transistor, 20 diode, 3 tube circuit on two circuit boards goes together in about 25 hours.

Fixed Level Microphone Gain . . . provides overmodulation protection by clipping any voice input above the predetermined level.

Relative Power/Signal Strength Meter . . . indicates relative power output when mike button is depressed; signal strength when in receive mode.

Front Panel Controls for Final Load, Final Tune and Driver Tune are easily adjustable for maximum power output.

Built-In Speaker . . . essential for mobile installations where space is at a premium. Delivers up to 2 watts of audio power.

Microphone Supplied . . . a PTT ceramic hand-held microphone is supplied with coil cord and hanger.

Headphone Jack . . . jack for low impedance phones is located on the rear apron.

Handsome . . . the HW-17 is housed in an attractive two-tone green wrinkle finish and matches the latest Heath designs.

Aug. 69

HW-17 SPECIFICATIONS

TRANSMITTER:

Frequency Coverage: 143.2 MHz to 148.2 MHz.

Power Input: 25 to 30 watts.

Output Impedance: 50-72 ohm unbalanced.

Power Output: 8 to 10 watts.

Transmitting Mode: A3 emission (AM).

Modulation Capability: Modulation is automatically limited to 100% or less.

Frequency Control: Limited to four internal crystals or an external VFO, such as the Heathkit Model HG-10B.

Crystal Holder: One HC6/U type and three FT243 types.

Crystal Multiplication: 18 times.

Microphone: Ceramic PTT (furnished).

Tubes: 7059 — oscillator and tripler; tripler. 12GN7 — doubler-driver. 8156 — PA final.

Final Tuning: Series tuned, link coupled.

Note: This transceiver is wired to power the Heathkit Model HG-10 series VFO.

RECEIVER:

Frequency Coverage: 143.2 MHz to 148.2 MHz.

Receiving Mode: Type A3 emission (AM).

Sensitivity: 1 microvolt or less for 10 dB signal-plus-noise to noise ratio (30% modulation at 400 Hz).

IF Selectivity: 27 kHz at 6 dB down.

Intermediate Frequencies: 24.965 MHz and 2 MHz.

Antenna Input Impedance: 50-72 ohm unbalanced.

Audio Output Power: 1 watt at less than 10% distortion. 2 watts maximum.

Transistors: (2) UC734 RF amplifier and mixer; (1) SE5023 HF oscillator; (4) 2N3694 IF amplifiers second mixer, second oscillator; (4) 2N3393 audio preamplifier, microphone amplifier, microphone squelch amplifier; (1) X29A829 Squelch gate; (2) 40050 audio output; (1) 2N1274 audio driver.

GENERAL:

Dial Calibration: Every 100 kHz.

Temperature Range: 20 degree C to +50 degree C.

Power Requirements: 120 or 240 volts AC input, 50-60 Hz.

Battery Saver: 8 watts.

Receiver Trans: 20 watts.

Spot: 35 watts.

Transmit: 100 watts.

Cabinet Dimensions: 14 1/8" W. x 8 1/2" D. x 6 1/8" H. including microphone and feet.

Net Weight: 13 lbs.

HWA-17-1 SPECIFICATIONS

Input Voltage: 12 to 15 volts DC.

Input Current: 10 amperes maximum.

Allowable Ambient Temperature: 10 degrees F to 122 degrees F.

High Voltage Output: 380 VDC, no load; 340 VDC at 150 mA load.

Ripple: Less than 1% at 150 mA.

Duty Cycle: 50%.

Conversion Frequency: 2500 Hz (approx.)

Dimensions: 3 7/8" W. x 7 5/16" L. x 2 1/2" H.

Net Weight: 3 lbs.

Note: A 13.5 volt DC input was used in determining the electrical specifications.

HEATHKIT-GERÄTE
GmbH

6079 Sprendlingen bei Frankfurt
Robert-Bosch-Straße Nr. 32-38
Tel. 06103 68971, 68972, 68973

ALTERNATE
WIRING FOR
240 VOLT
OPERATION

