

HEATHKIT[®] MANUAL

for the

**DELUXE QRP
CW TRANSCEIVER**
Model HW-9

595-3059



HEATH COMPANY • BENTON HARBOR, MICHIGAN

TABLE OF CONTENTS

Introduction	3	Final Assembly	85
Unpacking	4	Installation and Operation	86
Assembly Notes	5	Rear Panel Connections	86
Oscillator Circuit Board	9	Front Panel Controls	88
Parts List	9	In Case of Difficulty	89
Step-by-Step Assembly	13	Visual Checks	89
T/R Circuit Board	27	Precautions for Troubleshooting	90
Parts List	27	Checking Transistors and Diodes	90
Step-by-Step Assembly	31	Troubleshooting Charts	91
Chassis	49	Specifications	95
Parts List	49	Circuit Description	98
Step-by-Step Assembly	51	Circuit Board X-Ray Views	
Initial Tests	73 Illustration Booklet, Page 37	
Resistance Tests	73	Semiconductor Identification Charts	102
Alignment	77	Schematic	Fold-in
Initial Control Settings	77	Warranty	Inside front cover
HFO Alignment	78	Customer Service	Inside rear cover
VFO Alignment	79		
BFO Alignment	79		
Mixer Filter Alignment	80		
T/R Board Adjustments	81		

INTRODUCTION

The Heathkit Model HW-9 Deluxe QRP CW Transceiver is a compact 80-through 10-meter HF transceiver designed with the avid low-power CW operator in mind. It covers the lower 250 kHz of the 80, 40, 20, and 15-meter amateur bands. When you install the Model HWA-9 Accessory Band Pack, the Transceiver also covers the 30, 17, and 12-meter WARC bands and the lower 250 kHz of the 10-meter band. Broadband circuits eliminate the need to tune circuits within a band. Just turn the Band switch and select the desired frequency.

The design of the wide-band front-end stages eliminates the need for the customary RF amplifier in the receiver section. This results in a receiver that can properly handle incoming signals with a wide dynamic range. Also, only one frequency conversion is used in the main signal path of the receiver section. This is done to reduce spurious responses (birdies) and to maintain high image rejection.

Power for this Transceiver can be furnished by a power supply, such as the Heathkit Model PSA-9 Power Supply, or directly from any regulated 12.6 VDC source that can supply at least 1 ampere.

To align this Transceiver, you should have a VTVM (vacuum-tube voltmeter) or VOM (volt-ohmmeter), a frequency counter capable of measuring frequencies accurately up to at least 10 MHz, and a 50-ohm resistive dummy load.

The following features are also included in your Transceiver:

- Solid-state transmit/receive switching that permits full break-in operation.
- Continuously variable RF power output.
- Receiver incremental tuning (RIT).
- An audio-active filter with selectable wide or narrow selectivity.
- A front panel meter that indicates signal strength in receive and relative power in transmit.

This Transceiver is a handy addition to any ham shack for avid QRP operators, newcomers, or old timers alike.

UNPACKING

**DO NOT UNPACK ANY PART OF YOUR KIT
UNTIL A STEP DIRECTS YOU TO DO SO.**

Locate the "Pack Index Sheet" that is packed inside the main shipping carton for your Transceiver. Note that the shipping carton is divided into three smaller sections. These sections make up Packs 1 and 2 and the Final Pack, and may be made up of several bags, envelopes, small boxes, and loose parts. Do not unpack any of these parts until a step specifically directs you to do so.

When you check parts against a "Parts List," return any part or group of parts packaged in a bag or other container, with a part number on it, to its container after you identify it. Leave these parts there until you actually use them in a step. This will help prevent you from mixing up the parts, and help you identify the parts when you need them.

Some parts, however, are in a bag or envelope that is not marked with an actual part number, but with a packaging number that begins with the number "173-." These numbers are used for packaging purposes only and do not appear in the Manual "Parts Lists." Open each bag or envelope that is marked with only a "173-" packaging number to identify the parts it contains.

NOTE: Never use a "173-" packaging number if you must order a replacement part. Use only the part numbers listed in the Manual Parts List for this purpose.

Save all of the packaging material until you account for all of the parts.

ASSEMBLY NOTES

TOOLS

You will need these tools to assemble your kit.

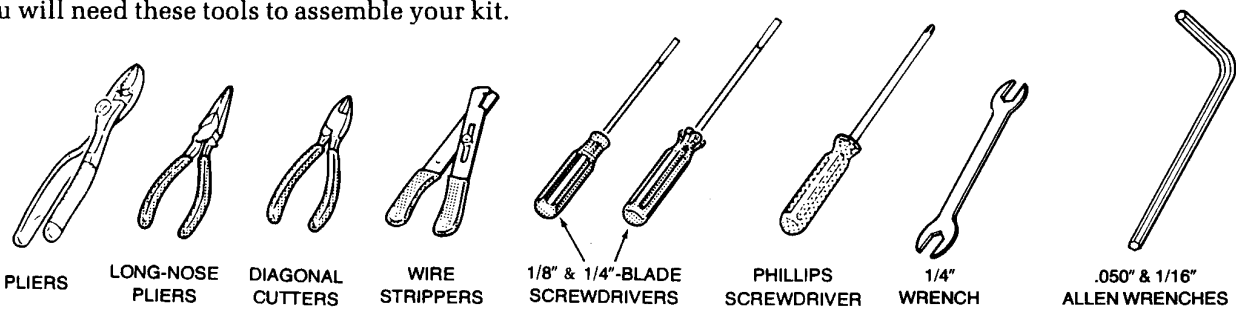

OTHER HELPFUL TOOLS

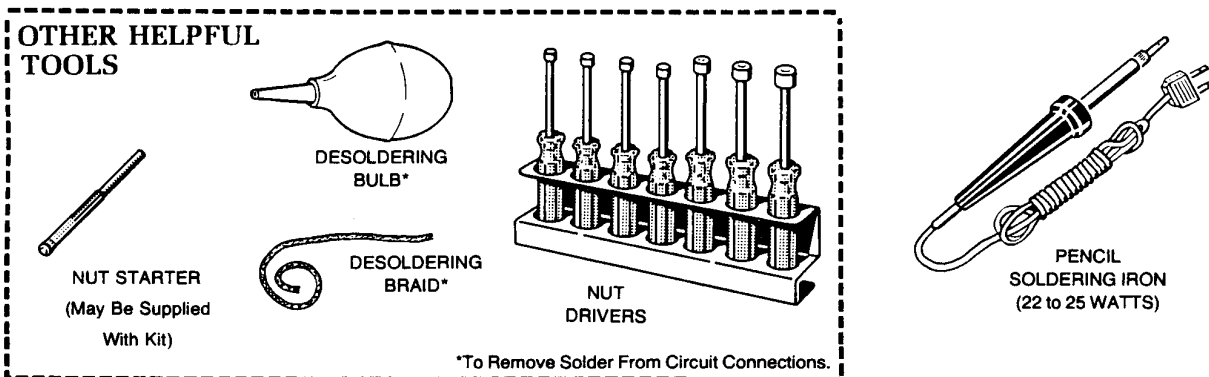

ASSEMBLY

1. Follow the instructions carefully. Read the entire step before you perform each operation.
2. The illustrations in the Manual are called Pictorials and Details. Pictorials show the overall operation for a group of assembly steps; Details generally illustrate a single step. When you are directed to refer to a certain Pictorial "for the following steps," continue using that Pictorial until you are referred to another Pictorial for another group of steps.
3. Most kits use a separate "Illustration Booklet" that contains illustrations (Pictorials, Details, etc.) that are too large for the Assembly Manual. Keep the "Illustration Booklet" with the Assembly Manual. The illustrations in it are arranged in Pictorial number sequence.
4. Position all parts as shown in the Pictorials.
5. Solder a part or a group of parts only when you are instructed to do so.

6. Each circuit part in an electronic kit has its own component number (R2, C4, etc.). Use these numbers when you want to identify the same part in the various sections of the Manual. These numbers, which are especially useful if a part has to be replaced, appear:
- In the Parts List,
 - At the beginning of each step where a component is installed,
 - In some illustrations,
 - In the Schematic,
 - In the section at the rear of the Manual.
7. When you are instructed to cut something to a particular length, use the scales (rulers) provided at the bottom of the Manual pages.

SAFETY WARNING: Avoid eye injury when you cut off excessive lead lengths. Hold the leads so they cannot fly toward your eyes.

SOLDERING

Soldering is one of the most important operations you will perform while assembling your kit. A good solder connection will form an electrical connection between two parts, such as a component lead and a circuit board foil. A bad solder connection could prevent an otherwise well-assembled kit from operating properly.

It is easy to make a good solder connection if you follow a few simple rules:

1. Use the right type of soldering iron. A 22 to 25-watt pencil soldering iron with a 1/8" or 3/16" chisel or pyramid tip works best.
2. Keep the soldering iron tip clean. Wipe it often on a wet sponge or cloth; then apply solder to the tip to give the entire tip a wet look. This process is called tinning, and it will protect the tip and enable you to make good connections. When solder tends to "ball" or does not stick to the tip, the tip needs to be cleaned and retinned.

NOTE: Always use rosin core, radio-type solder (60:40 tin-lead content) for all of the soldering in this kit. This is the type we have supplied with the parts. The Warranty will be void and we will not service any kit in which acid core solder or paste has been used.

Heathkit®

PARTS

Resistors are identified in Parts Lists and steps by their resistance value in Ω (ohms), $k\Omega$ (kilohms), or $M\Omega$ (megohms). They are usually identified by a color code and four or five color bands, where each color represents a number. These colors (except for the last band, which indicates a resistor's "tolerance") will be given in the steps in their proper order. Therefore, the following color code is given for information only. NOTE: Occasionally, a "precision" or "power" resistor may have the value stamped on it.

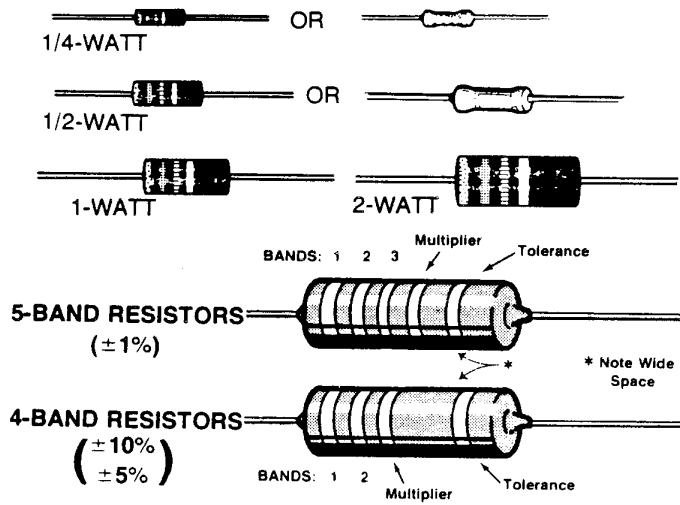

Band 1 1st Digit	
Color	Digit
Black	0
Brown	1
Red	2
Orange	3
Yellow	4
Green	5
Blue	6
Violet	7
Gray	8
White	9

Band 2 2nd Digit	
Color	Digit
Black	0
Brown	1
Red	2
Orange	3
Yellow	4
Green	5
Blue	6
Violet	7
Gray	8
White	9

Band 3 (if used) 3rd Digit	
Color	Digit
Black	0
Brown	1
Red	2
Orange	3
Yellow	4
Green	5
Blue	6
Violet	7
Gray	8
White	9

Multiplier	
Color	Multiplier
Black	1
Brown	10
Red	100
Orange	1,000
Yellow	10,000
Green	100,000
Blue	1,000,000
Silver	0.01
Gold	0.1

Resistance Tolerance	
Color	Tolerance
Silver	$\pm 10\%$
Gold	$\pm 5\%$
Red	$\pm 2\%$
Brown	$\pm 1\%$
Green	$\pm .5\%$
Blue	$\pm .25\%$
Violet	$\pm .1\%$
Gray	$\pm .05\%$

Capacitors will be called out by their capacitance value in μF (microfarads) or pF (picofarads) and type: ceramic, Mylar*, electrolytic, etc. Some capacitors may have their value printed in the following manner:

EXAMPLES:

$151K = 15 \times 10 = 150 pF$
 $759 = 75 \times 0.1 = 7.5 pF$

NOTE: The letter "R" may be used at times to signify a decimal point: as in: $2R2 = 2.2 (pF \text{ or } \mu F)$.

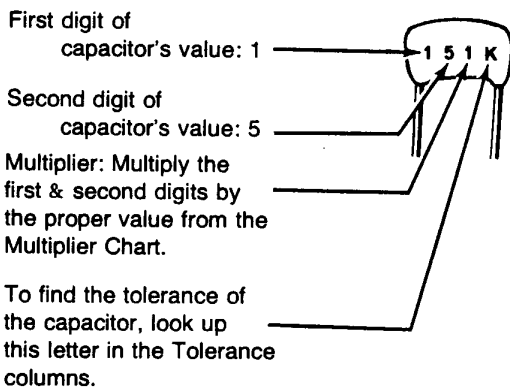

MULTIPLIER		TOLERANCE OF CAPACITOR		
FOR THE NUMBER:	MULTIPLY BY:	10 pF OR LESS	LETTER	OVER 10 pF
0	1	$\pm 0.1 pF$	B	
1	10	$\pm 0.25 pF$	C	
2	100	$\pm 0.5 pF$	D	
3	1000	$\pm 1.0 pF$	F	$\pm 1\%$
4	10,000	$\pm 2.0 pF$	G	$\pm 2\%$
5	100,000		H	$\pm 3\%$
			J	$\pm 5\%$
8	0.01		K	$\pm 10\%$
9	0.1		M	$\pm 20\%$

*DuPont Registered Trademark.

SPECIAL ASSEMBLY NOTES

NOTE: The following suggestions will not necessarily improve the operation of your kit. They will, however, help you troubleshoot it (if it ever becomes necessary), and help you perform the "Circuit Board Checkout" steps at the end of the assembly sections of this Manual. And you will have a more professionally-built kit when you finish.

1. When you install resistors, always position each resistor so you can read the bands on the resistor in the same direction as you can read the printing on the circuit board (see Figure 1). For resistors that have the value printed on them instead of color bands, install these resistors so the values are facing away from the circuit board and read in the same direction as the printing on the circuit board.

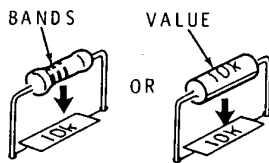

Figure 1

2. When you install ceramic, Mylar, or mica capacitors, always position each capacitor so you can read the value on the capacitor in the same direction as you can read the printing on the circuit board (see Figure 2).

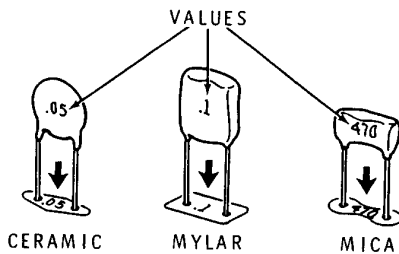

Figure 2

3. When you install electrolytic or other tubular capacitors, always position each capacitor so the value is facing away from the circuit board (see Figure 3). Be sure to observe the correct polarity when you install electrolytic capacitors (as you will be directed in the steps). Other, non-polarized, capacitors should be installed so you can read the values in the same direction as the printing on the circuit board.

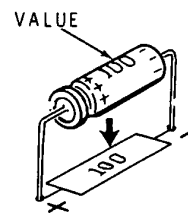

Figure 3

4. Install diodes so the type numbers or part numbers are facing away from the circuit board. Be sure to match the band on one end of each diode with the band mark on the circuit board.

OSCILLATOR CIRCUIT BOARD

PARTS LIST

Remove the parts from Pack #1. Then check each part against the following list. Do not remove components that are supplied on a tape from the tape until you use them in a step. Return any part that is packed in an individual envelope, with the part number on it, back to the envelope after you identify it until that part is called for in a step. Do not throw away any packing material until all of the parts are accounted for.

To order a replacement part, always include the PART NUMBER. Use the Parts Order Form furnished with this kit. If a Parts Order Form is not available, refer to "Replacement Parts" inside the rear cover of this Manual. For prices, refer to the separate "Heath Parts Price List."

TAPED COMPONENTS

NOTE: These parts are taped on a strip which was checked before shipment. Since these parts are taped in the order of assembly, you may not wish to check them against the following list.

HEATH Part No.	QTY.	DESCRIPTION	CIRCUIT Comp. No.	HEATH Part No.	QTY.	DESCRIPTION	CIRCUIT Comp. No.
RESISTORS				Resistors (Cont'd)			
NOTE: The following resistors are rated at 1/4-watt and have a tolerance of 5%. A 5% tolerance is indicated by a fourth color band of gold.							
6-470-12	3	47 Ω (yel-viol-blk)	R128, R129, R142	6-271-12	5	270 Ω (red-viol-brn)	R155, R159, R161, R164, R165
6-101-12	5	100 Ω (brn-blk-brn)	R104, R138, R147, R153, R174	6-331-12	2	330 Ω (org-org-brn)	R135, R148
6-221-12	3	220 Ω (red-red-brn)	R123, R124, R143	6-471-12	1	470 Ω (yel-viol-brn)	R156
				6-681-12	2	680 Ω (blu-gry-brn)	R145, R151
				6-152-12	2	1500 Ω (brn-grn-red)	R158, R163
				6-222-12	5	2200 Ω (red-red-red)	R107, R109, R113, R117, R166
				6-332-12	2	3300 Ω (org-org-red)	R157, R162

HEATH Part No.	QTY.	DESCRIPTION	CIRCUIT Comp. No.	HEATH Part No.	QTY.	DESCRIPTION	CIRCUIT Comp. No.
Resistors (Cont'd)				CAPACITORS			
6-392-12	2	3900 Ω (org-wht-red)	R137, R139	21-761	32	.01 μ F (103) glass ceramic	C102, C107, C112, C121, C129, C139, C141, C143, C145, C151, C153, C157, C162, C174, C176, C178, C181, C189, C191, C192, C193, C195, C197, C203, C209, C212, C214, C216, C217, C218, C219, C226
6-682-12	2	6800 Ω (blu-gry-red)	R168, R169				
6-822-12	1	8200 Ω (gry-red-red)	R105				
6-103-12	3	10 k Ω (brn-blk-org)	R118, R132, R133				
6-123-12	3	12 k Ω (brn-red-org)	R108, R110, R114				
6-223-12	5	22 k Ω (red-red-org)	R102, R103, R141, R171, R172				
6-333-12	1	33 k Ω (org-org-org)	R127				
6-473-12	1	47 k Ω (yel-viol-org)	R154				
6-104-12	3	100 k Ω (brn-blk-yel)	R126, R144, R152				
6-224-12	1	220 k Ω (red-red-yel)	R136				
6-334-12	1	330 k Ω (org-org-yel)	R134				
6-155-12	1	1.5 M Ω (brn-grn-grn)	R146	21-762	1	.1 μ F (104) glass ceramic	C177
				DIODES			
				56-24	1	1N458	D119
				56-26	2	1N191 (brn-wht-brn)	D138, D139
				56-56	2	1N4149	D141, D142
				56-646	17	BA-244 (red-yel-yel)	D101, D102, D103, D104, D107, D108, D112, D113, D121, D122, D123, D124, D127, D128, D132, D133, D143
				57-65	1	1N4002	D118

Heathkit®

NON-TAPED PARTS

The following parts are not taped on strips. The key numbers correspond to the numbers on the "Oscillator Circuit Board Parts Pictorial" (Illustration Booklet, Page 1).

KEY No.	HEATH Part No.	QTY.	DESCRIPTION	CIRCUIT Comp. No.	KEY No.	HEATH Part No.	QTY.	DESCRIPTION	CIRCUIT Comp. No.
CAPACITORS					INDUCTORS				
Mica									
A1	20-97	2	50 pF	C207, C208	B1	40-1785	4	.14 μ H coil (violet)	L107, L108, L112, L113
A1	20-110	1	75 pF	C205	B2	40-2076	6	.3 μ H coil	L101, L102, L124, L125, L127, L129
A1	20-119	2	90 pF	C127, C128	B2	40-2075	3	.44 μ H coil	L103, L104, L137
A1	20-102	1	100 pF	C206	B2	40-2070	1	3 μ H coil	L135
A1	20-124	1	115 pF	C149	B3	40-2111	1	5.5 μ H coil	L118
A1	20-178	2	160 pF	C118, C119	B4	45-73	1	2.2 μ H choke (red-red-gold)	L133
A1	20-105	1	180 pF	C111	B5	45-625	2	4.7 μ H choke (yel-viol-gold)	L122, L123
A1	20-108	1	200 pF	C109	B5	45-621	4	100 μ H choke (brn-blk-brn)	L119, L121, L134, L136
A1	20-115	2	300 pF	C105, C106					
Ceramic					TRANSISTORS				
A2	21-33	1	3.3 pF	C126	NOTE: Transistors may be marked for identification in any of the following four ways:				
A2	21-168	4	4.7 pF	C117, C179, C188, C194	1. Part number.				
A2	21-78	3	5 pF	C167, C171, C173	2. Type number.				
A2	21-169	2	6 pF	C108, C169	3. Part number and type number.				
A2	21-115	1	9 pF	C104	4. Part number with a type number other than the one listed.				
A2	21-3	4	10 pF	C168, C172, C202, C211	C1	417-234	1	2N3638A	Q106
A2	21-60	1	18 pF	C186	C1	417-293	4	2N5770	Q101, Q108, Q109, Q111
A2	21-84	1	24 pF	C161	C2	417-863	1	MFE131	Q107
A2	21-7	3	33 pF	C101, C184, C213	C1	417-169	3	MPF105	Q102, Q105, Q112
A2	21-147	2	47 pF	C156, C175	C1	417-801	5	MPSA20	Q103, Q104, Q113, Q114, Q115
A2	21-190	1	50 pF	C182	CRYSTALS				
A2	21-54	1	75 pF	C225	D1	404-639	1	8.8314 MHz	Y109
A2	21-75	1	100 pF (100K)	C152	D1	404-664	1	18.330 MHz	Y101
A2	21-22	1	220 pF	C221	D1	404-665	1	21.830 MHz	Y102
A2	21-17	1	270 pF	C222	D1	404-667	1	28.830 MHz	Y104
A2	21-722	1	330 pF	C201	D1	404-669	1	35.830 MHz	Y106
A2	21-56	1	470 pF	C196					
A2	21-13	1	500 pF	C198					
A2	21-191	3	510 pF	C183, C185, C187					
A2	21-171	2	680 pF	C199, C223					
A2	21-140	2	.001 μ F (1000 pF)	C103, C215					

KEY No.	HEATH Part No.	QTY.	DESCRIPTION	CIRCUIT Comp. No.
---------	----------------	------	-------------	-------------------

KEY No.	HEATH Part No.	QTY.	DESCRIPTION	CIRCUIT Comp. No.
---------	----------------	------	-------------	-------------------

CONNECTORS

E1	432-121	3	PCB pin	
E2	432-134	5	Wire socket	
E3	432-969	1	5-pin plug	

WIRE—CABLE

340-1	3"	Large bare wire
340-8	18"	Small bare wire
343-12	10' 6"	Shielded cable
344-2	5"	Black stranded wire
344-59	2'	White solid wire
344-3	18"	Large red stranded wire
344-163	6"	Small black solid wire
344-170	7'	Violet solid wire
347-55	4'	8-wire cable

MISCELLANEOUS

F1	10-918	1	500 Ω control	R173
F1	10-941	1	100 kΩ control	R131
	85-2801-1	1	Oscillator circuit board	
F2	206-1463	1	Oscillator shield	
F3	475-10	10	Ferrite bead	
F4		1	Blue and white label*	
	597-260	1	Parts Order Form*	
		1	Taped Component Chart	
		1	Assembly Manual (see Page 1 for the part number)	
			Solder	

* These items may be packed inside the Manual.



STEP-BY-STEP ASSEMBLY

Refer to Pictorial 1-1 (Illustration Booklet, Page 2) as you read the following notes and steps.

NOTES:

1. Many circuit board drawings, such as the one shown in Pictorial 1-1, are divided into two or more sections. These sections show you which area of the circuit board you are working in for a specific series of steps.
2. Refer to the "Taped Components Chart." Note that it is divided into numbered sections that match the sections on the circuit board.
3. Each series of steps has you installing parts in a top-to-bottom, left-to-right sequence. Occasionally, you may be directed to install a component in an area out of sequence. These components are each identified in the step and on the Pictorial with a special callout.
4. Check off each step as you perform it. You may also wish to place a check mark near each component on the Pictorial as you install it.
5. In general, solder instructions are given only at the end of a series of similar steps. You may solder more often, if you desire.

In the following steps, you will be given detailed instructions on how to install and solder the first part on the circuit board. Read and perform each step carefully. Then use the same procedure whenever you install parts on a circuit board.

- () Note that the circuit board has foil on one side and component outlines on the other. The side with the component outlines is referred to as the "component side."

Position the circuit board as shown in the Pictorial with the component side up. Always install components on the component side of the circuit board,

and solder the leads to the foil on the other side unless a step specifically directs you otherwise.

- () C176: Hold a .01 μ F (103) glass ceramic capacitor as shown and bend the leads straight down to fit the hole spacing on the circuit board.

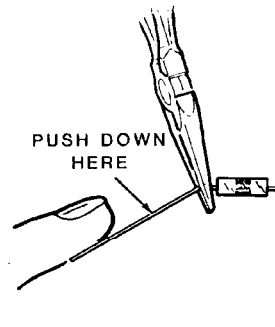

- () Start the leads into the holes at the capacitor's location at the top of Section 1 of the circuit board. This type of capacitor can be positioned either way. NOTE: Glass ceramic capacitors are identified on the circuit board by the following outlines:

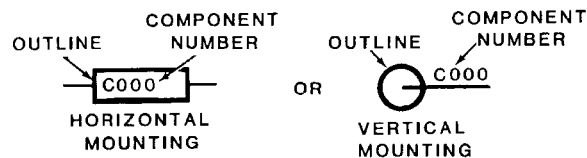

- () Press the capacitor against the circuit board. Then bend the leads outward slightly to hold it in place.



- () Solder the capacitor leads to the circuit board as follows:

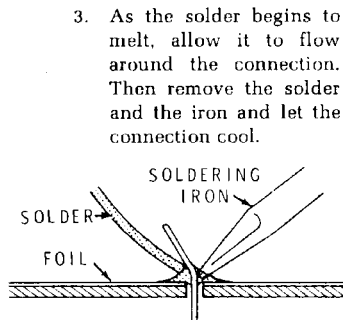
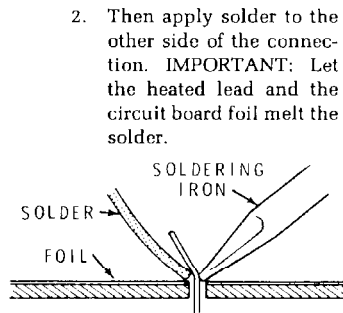
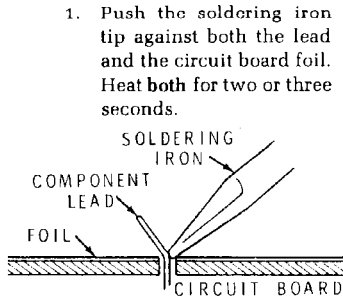

- () Cut off the excess lead lengths close to the connection. **WARNING:** Clip the leads so the ends will not fly toward your eyes.
- () Check each connection. Compare it to the illustrations on Page 15. After you have checked the solder connections, proceed with the assembly on this page. Use the same soldering procedure for each connection.

Now start at the top of Section 1 and install the following components. The sequence of the steps matches the locations of the components on the circuit board. **NOTE:** Make sure you installed capacitor C176 in an earlier step.

In order to make the assembly easier, you may wish to precut all of the parts from a section and, as you do, prebend the leads and lay the parts on your work surface in the order of assembly. Then you can hold the circuit board while you install the parts in sequence without interruption.

NOTES:

1. In some of the following steps you will install diodes. Whenever you install a diode, always match the banded end of the diode with the band mark on the circuit board. A diode will not work properly if it is installed backwards.
2. The banded end will always be positioned toward the colored tape on the "Taped Components Chart."

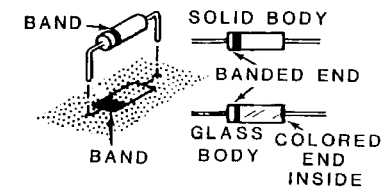
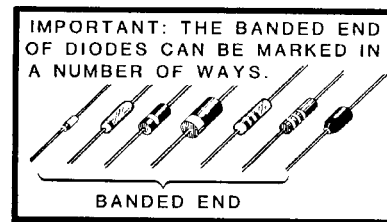

CAUTION: ALWAYS POSITION THE BANDED END OF A DIODE AS SHOWN ON THE CIRCUIT BOARD.

A GOOD SOLDER CONNECTION

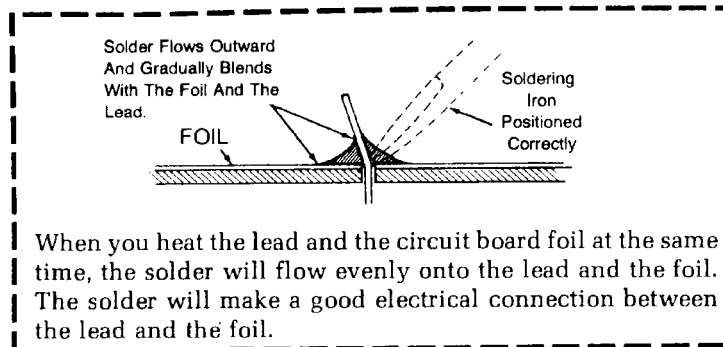

POOR SOLDER CONNECTIONS

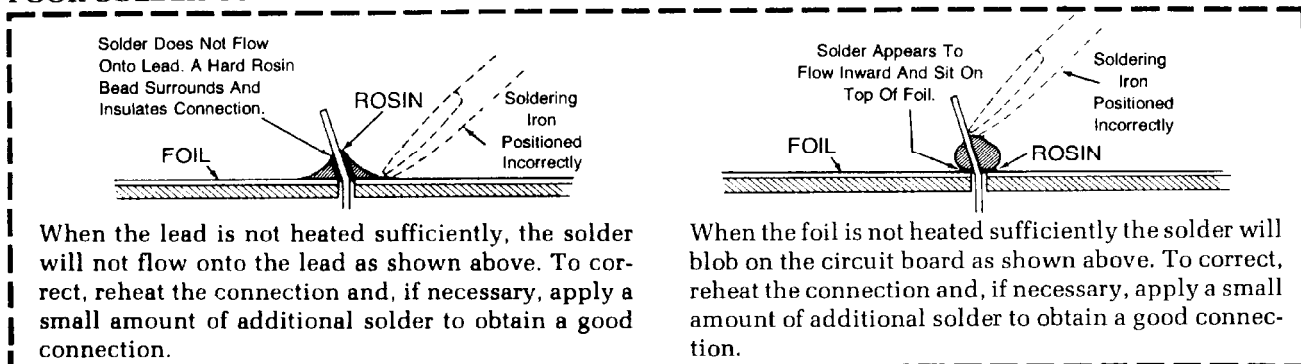

SOLDER BRIDGES

A solder bridge between two adjacent foils is shown in photograph A. Photograph B shows how the connection should appear. A solder bridge may occur if you accidentally touch an adjacent previously soldered connection, if you use too much solder, or if you "drag" the soldering iron across other foils as you remove it from the connection. A good rule to follow is: always take a good look at the foil area around each lead before you solder it. Then, when you solder the connection, make sure the solder remains in this area and does not bridge to another foil. This is especially important when the foils are small and close together. NOTE: It is alright for solder to bridge two connections on the same foil.

Use only enough solder to make a good connection, and lift the soldering iron straight up from the circuit board. If a solder bridge should develop, turn the circuit board foil-side-down and heat the solder between connections. The excess solder will run onto the tip of the soldering iron, and this will remove the solder bridge. NOTE: The foil side of most circuit boards has a coating on it called "solder resist." This is a protective insulation to help prevent solder bridges.

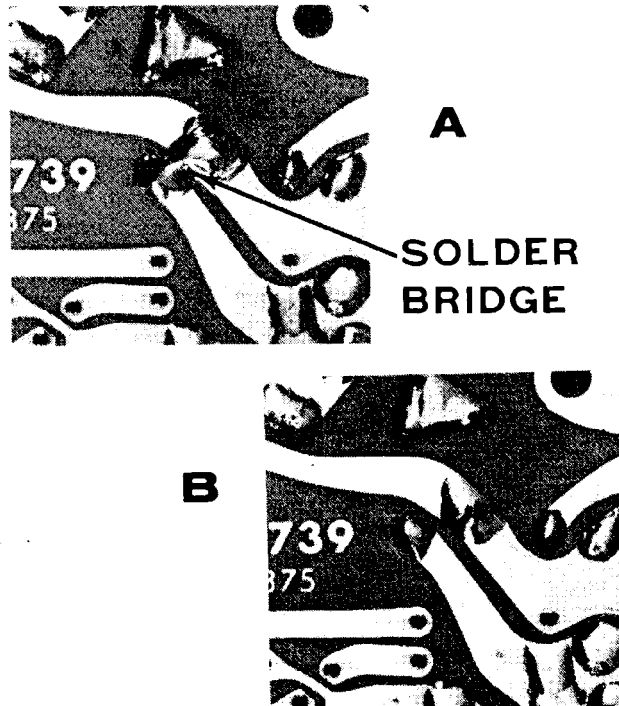

- () D139: 1N191 diode (brn-wht-brn, #56-26).
NOTE: Diodes are identified on the circuit board by the following outline:

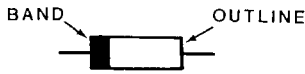

- () D138: 1N191 diode (brn-wht-brn, #56-26).
- () C177: .1 μ F (104) glass ceramic capacitor.
- () R103: 22 k Ω (red-red-org) resistor. NOTE: Resistors are identified on the circuit board by the following outlines:

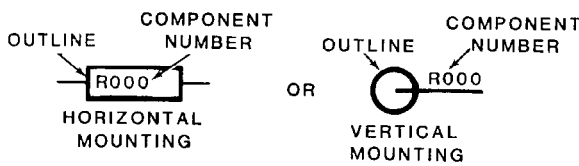

- () C102: .01 μ F (103) glass ceramic capacitor.
- () R102: 22 k Ω (red-red-org) resistor.
- () R104: 100 Ω (brn-blk-brn) resistor.
- () R141: 22 k Ω (red-red-org) resistor.
- () C178: .01 μ F (103) glass ceramic capacitor.
- () R137: 3900 Ω (org-wht-red) resistor.
- () R136: 220 k Ω (red-red-yel) resistor.
- () R135: 330 Ω (org-org-brn) resistor. NOTE: Mount this resistor vertically above its outline as shown below:

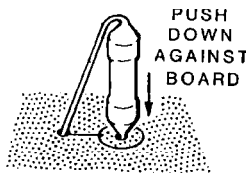

- () D119: 1N458 diode (#56-24).

- () Solder the leads to the foil and cut off the excess lead lengths.

Install components in Section 2 of the circuit board as follows:

- () R105: 8200 Ω (gry-red-red) resistor.
- () R139: 3900 Ω (org-wht-red) resistor.
- () R142: 47 Ω (yel-viol-blk) resistor.
- () R138: 100 Ω (brn-blk-brn) resistor.
- () C189: .01 μ F (103) glass ceramic capacitor.
- () R129: 47 Ω (yel-viol-blk) resistor.
- () R134: 330 k Ω (org-org-yel) resistor.
- () R128: 47 Ω (yel-viol-blk) resistor.

- () Solder the leads to the foil and cut off the excess lead lengths.

Install components in Section 3 of the circuit board as follows:

NOTE: Be sure to position the banded end of the diode toward the band mark on the circuit board. If your BA-244 diodes are marked with a color code (red-yel-yel), position the red band toward the band mark on the circuit board.

- () D101: BA-244 (red-yel-yel, #56-646) diode.
- () D103: BA-244 (red-yel-yel, #56-646) diode.

NOTE: Occasionally, you will be directed to skip certain components. These components will be installed later if you have the Model HWA-9 Accessory Band Pack.

- () Skip D105.
- () D107: BA-244 (red-yel-yel, #56-646) diode.
- () Skip D109.
- () D112: BA-244 (red-yel-yel, #56-646) diode.
- () Skip D114 and D116.
- () C181: .01 μ F (103) glass ceramic capacitor.

Heathkit®

- () R127: 33 k Ω (org-org-org) resistor.
- () C197: .01 μ F (103) glass ceramic capacitor.
- () R126: 100 k Ω (brn-blk-yel) resistor.
- () Solder the leads to the foil and cut off the excess lead lengths.

Install components in Section 4 of the circuit board as follows:

- () C107: .01 μ F (103) glass ceramic capacitor.
- () C112: .01 μ F (103) glass ceramic capacitor.
NOTE: Mount this capacitor vertically above its outline (similar to the way you mounted the vertical resistors earlier).
- () Skip C116.
- () C121: .01 μ F (103) glass ceramic capacitor.
- () Skip C125.
- () C129: .01 μ F (103) glass ceramic capacitor.
- () Skip C134 and C138.
- () R145: 680 Ω (blu-gry-brn) resistor.
- () R143: 220 Ω (red-red-brn) resistor.
- () R132: 10 k Ω (brn-blk-org) resistor.
- () C191: .01 μ F (103) glass ceramic capacitor.
- () R133: 10 k Ω (brn-blk-org) resistor.
- () C192: .01 μ F (103) glass ceramic capacitor.
- () C193: .01 μ F (103) glass ceramic capacitor.
- () C195: .01 μ F (103) glass ceramic capacitor.
- () D118: 1N4002 (#57-65) diode.
- () Solder the leads to the foil and cut off the excess lead lengths.

Install components in Section 5 of the circuit board as follows:

- () D102: BA-244 (red-yel-yel, #56-646) diode.
- () C139: .01 μ F (103) glass ceramic capacitor.
- () D104: BA-244 (red-yel-yel, #56-646) diode.
- () C141: .01 μ F (103) glass ceramic capacitor.
- () Skip D106 and C142.
- () C143: .01 μ F (103) glass ceramic capacitor.
- () D108: BA-244 (red-yel-yel, #56-646) diode.
- () Skip C144 and D111.
- () C145: .01 μ F (103) glass ceramic capacitor.
- () D113: BA-244 (red-yel-yel, #56-646) diode.
- () Skip C146, D115, C147, and D117.
- () R148: 330 Ω (org-org-brn) resistor.
- () C203: .01 μ F (103) glass ceramic capacitor.
- () R146: 1.5 M Ω (brn-grn-grn) resistor.
- () R147: 100 Ω (brn-blk-brn) resistor.
- () Solder the leads to the foil and cut off the excess lead lengths.

Install components in Section 6 of the circuit board as follows:

- () R107: 2200 Ω (red-red-red) resistor.
- () D121: BA-244 (red-yel-yel, #56-646) diode.
- () R109: 2200 Ω (red-red-red) resistor.
- () D123: BA-244 (red-yel-yel, #56-646) diode.
- () Skip R111 and D125.
- () R113: 2200 Ω (red-red-red) resistor.

- () D127: BA-244 (red-yel-yel, #56-646) diode.
- () Skip R115 and D129.
- () R117: 2200 Ω (red-red-red) resistor.
- () D132: BA-244 (red-yel-yel, #56-646) diode.
- () Skip R119, D134, R121, and D136.
- () R144: 100 k Ω (brn-blk-yel) resistor.
- () C174: .01 μ F (103) glass ceramic capacitor.
- () C219: .01 μ F (103) glass ceramic capacitor.
- () D143: BA-244 (red-yel-yel, #56-646) diode.
- () R164: 270 Ω (red-viol-brn) resistor.
- () C216: .01 μ F (103) glass ceramic capacitor.
NOTE: Mount this capacitor vertically.
- () Solder the leads to the foil and cut off the excess lead lengths.

Install components in Section 7 of the circuit board as follows:

- () C151: .01 μ F (103) glass ceramic capacitor.
- () Skip C155, C159, and C164.
- () R171: 22 k Ω (red-red-org) resistor.
- () R174: 100 Ω (brn-blk-brn) resistor.
- () R166: 2200 Ω (red-red-red) resistor. NOTE: Mount this resistor vertically.
- () R162: 3300 Ω (org-org-red) resistor.
- () C217: .01 μ F (103) glass ceramic capacitor.
- () R163: 1500 Ω (brn-grn-red) resistor.
- () R165: 270 Ω (red-viol-brn) resistor.
- () C214: .01 μ F (103) glass ceramic capacitor.
- () Solder the leads to the foil and cut off the excess lead lengths.

Install components in Section 8 of the circuit board as follows:

- () C153: .01 μ F (103) glass ceramic capacitor.
- () C157: .01 μ F (103) glass ceramic capacitor.
- () C162: .01 μ F (103) glass ceramic capacitor.
- () Skip C166.
- () R172: 22 k Ω (red-red-org) resistor.
- () C218: .01 μ F (103) glass ceramic capacitor.
- () C226: .01 μ F (103) glass ceramic capacitor.
- () R159: 270 Ω (red-viol-brn) resistor.
- () R157: 3300 Ω (org-org-red) resistor.
- () R158: 1500 Ω (brn-grn-red) resistor.
- () R161: 270 Ω (red-viol-brn) resistor.
- () R156: 470 Ω (yel-viol-brn) resistor. NOTE: Mount this resistor vertically.
- () Solder the leads to the foil and cut off the excess lead lengths.

Install components in Section 9 of the circuit board as follows:

- () R108: 12 k Ω (brn-red-org) resistor.
- () R110: 12 k Ω (brn-red-org) resistor.
- () Skip R112.
- () R114: 12 k Ω (brn-red-org) resistor.
- () Skip R116.
- () R118: 10 k Ω (brn-blk-org) resistor.
- () Skip R120 and R122.
- () R151: 680 Ω (blu-gry-brn) resistor.
- () R153: 100 Ω (brn-blk-brn) resistor.

Heathkit®

- () R154: 47 k Ω (yel-viol-org) resistor.
- () R155: 270 Ω (red-viol-brn) resistor.
- () C212: .01 μ F (103) glass ceramic capacitor.
- () Solder the leads to the foil and cut off the excess lead lengths.

Install components in Section 10 of the circuit board as follows:

- () D122: BA-244 (red-yel-yel, #56-646) diode.
- () D124: BA-244 (red-yel-yel, #56-646) diode.
- () R169: 6800 Ω (blu-gry-red) resistor.
- () Skip D126.
- () R123: 220 Ω (red-red-brn) resistor.
- () D128: BA-244 (red-yel-yel, #56-646) diode.
- () Skip D131.
- () R168: 6800 Ω (blu-gry-red) resistor.
- () D133: BA-244 (red-yel-yel, #56-646) diode.
- () R124: 220 Ω (red-red-brn) resistor.
- () Skip D135 and D137.
- () D141: 1N4149 (#56-56) diode.
- () C209: .01 μ F (103) glass ceramic capacitor.
- () R152: 100 k Ω (brn-blk-yel) resistor. NOTE: Mount this resistor vertically.
- () D142: 1N4149 (#56-56) diode.
- () Solder the leads to the foil and cut off the excess lead lengths.

Refer to Pictorial 1-2 (Illustration Booklet, Page 3) for the following steps.

Install parts in Section 1 of the circuit board as follows. NOTE: The following parts are not taped on strips.

NOTE: When a step directs you to install a PCB pin in a circuit board, push the shorter end of the pin as far as possible into the circuit board hole. Then turn the circuit board over and solder the pin to the foil.

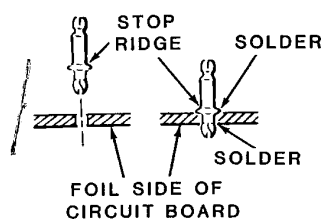

- () PCB pin at RF.

- () PCB pin at METER.

NOTE: When a step directs you to install a wire socket in a circuit board, push the tapered end of the socket as far as possible into the circuit board hole. Then turn the circuit board over and solder the socket to the foil. Try not to fill the socket with solder.

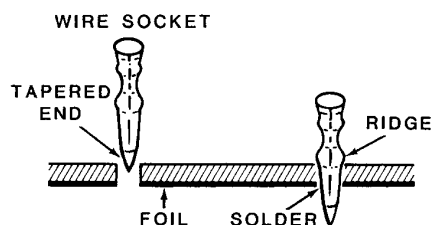

- () Wire socket at TP101.

NOTE: When a step directs you to install one or more ferrite beads, use a 1" small bare wire as shown below.

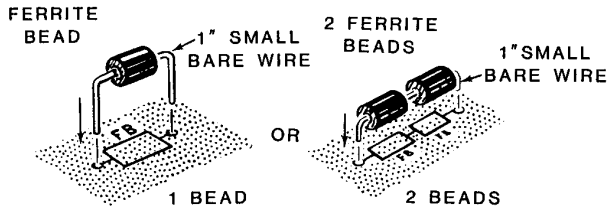

- Two ferrite beads at FB-FB.

NOTE: Use the same procedure to install chokes as you do resistors.

- L121: 100 μ H (brn-blk-brn, #45-621) choke.
- Solder the leads to the foil and cut off the excess lead lengths.

Install the following parts in Section 2 of the circuit board.

- L122: 4.7 μ H (yel-viol-gold, #45-625) choke. NOTE: Mount this choke vertically.
- L123: 4.7 μ H (yel-viol-gold, #45-625) choke. NOTE: Mount this choke vertically.
- L119: 100 μ H (brn-blk-brn, #45-621) choke.

NOTE: When a step calls for solid wire, cut the wire to the indicated length. Then remove 1/4" of insulation from each end.

- W105: 7/8" violet solid wire. NOTE: Wires are indicated on the circuit board by the following outline:

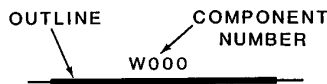

- Solder the leads to the foil and cut off the excess lead lengths.

Install parts in Section 3 of the circuit board as follows:

- Ferrite bead at FB.
- Wire socket at TP102.
- Two ferrite beads at FB-FB.
- PCB pin at E.
- Wire socket at GND.
- Solder the leads to the foil and cut off the excess lead lengths.
- Install four ferrite beads in Section 4 of the circuit board at the indicated locations. NOTE: Be sure to skip the four locations indicated on the Pictorial.
- Solder the leads to the foil and cut off the excess lead lengths.

Install parts in Section 5 of the circuit board as follows:

- W101: 1" small bare wire.
- W104: 1" small bare wire.
- L133: 2.2 μ H (red-red-gold, #45-73) choke.
- Solder the leads to the foil and cut off the excess lead lengths.

Install parts in Section 6 of the circuit board as follows:

- Wire socket at TP103.
- Ferrite bead at FB.
- Solder the leads to the foil and cut off the excess lead lengths.

Install parts in Section 7 of the circuit board as follows:

- W102: 1-1/4" violet solid wire.

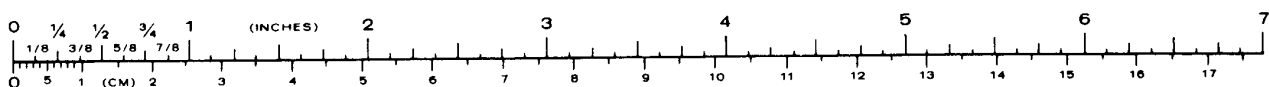

Heathkit®

- () W106: 7/8" violet solid wire.
- () W103: 7/8" violet solid wire.
- () Wire socket at TP104.
- () L134: 100 μ H (brn-blk-brn, #45-621) choke.
- () L136: 100 μ H (brn-blk-brn, #45-621) choke.
- () Solder the leads to the foil and cut off the excess lead lengths.

Refer to Pictorial 1-3 (Illustration Booklet, Page 4) for the following steps.

Install capacitors in Section 1 of the circuit board as follows:

NOTE: In some of the following steps, you will install disc-type ceramic capacitors. When you install these ceramic capacitors, do not push the insulated portion of the leads into the circuit board holes. This could make it difficult to solder the leads to the foil.

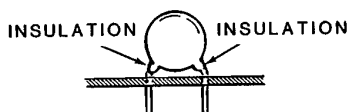

- () C101: 33 pF ceramic.
- () C103: .001 μ F (1000 pF) ceramic.
- () C198: 500 pF ceramic.
- () C196: 470 pF ceramic.
- () C194: 4.7 pF ceramic.
- () C188: 4.7 pF ceramic.
- () C186: 18 pF ceramic.
- () Solder the leads to the foil and cut off the excess lead lengths.

Install capacitors in Section 2 of the circuit board as follows:

- () C105: 300 pF mica.
- () C109: 200 pF mica.
- () Skip C114.
- () C118: 160 pF mica.
- () Skip C123.
- () C127: 90 pF mica.
- () Skip C132 and C136.
- () C199: 680 pF ceramic.
- () C201: 330 pF ceramic.
- () C179: 4.7 pF ceramic.
- () C182: 50 pF ceramic.
- () C184: 33 pF ceramic.
- () Solder the leads to the foil and cut off the excess lead lengths.

Install capacitors in Section 3 of the circuit board as follows.

- () C104: 9 pF ceramic.
- () C108: 6 pF ceramic.
- () Skip C113.
- () C117: 4.7 pF ceramic.
- () Skip C122.
- () C126: 3.3 pF ceramic.
- () Skip C131 and C135.
- () C202: 10 pF ceramic.

() C187: 510 pF ceramic.

() C185: 510 pF ceramic.

() C183: 510 pF ceramic.

() Solder the leads to the foil and cut off the excess lead lengths.

Install capacitors in Section 4 of the circuit board as follows:

() C106: 300 pF mica.

() C111: 180 pF mica.

() Skip C115.

() C119: 160 pF mica.

() Skip C124.

() C128: 90 pF mica.

() Skip C133 and C137.

() Solder the leads to the foil and cut off the excess lead lengths.

Install capacitors in Section 5 of the circuit board as follows:

() C149: 115 pF mica.

() Skip C154, C158, and C163.

() C175: 47 pF ceramic.

() Solder the leads to the foil and cut off the excess lead lengths.

Install capacitors in Section 6 of the circuit board as follows:

() C152: 100 pF (100K) ceramic.

() C156: 47 pF ceramic.

() C161: 24 pF ceramic.

() Skip C165.

() C223: 680 pF ceramic.

() C221: 220 pF ceramic.

() C222: 270 pF ceramic.

() C225: 75 pF ceramic.

() C215: .001 μ F (1000 pF) ceramic.

() C213: 33 pF ceramic.

() Solder the leads to the foil and cut off the excess lead lengths.

Install capacitors in Section 7 of the circuit board as follows:

() C168: 10 pF ceramic.

() C167: 5 pF ceramic.

() C172: 10 pF ceramic.

() C171: 5 pF ceramic.

() C169: 6 pF ceramic.

() C173: 5 pF ceramic.

() C205: 75 pF mica.

() C211: 10 pF ceramic.

() C206: 100 pF mica.

() C207: 50 pF mica.

() C208: 50 pF mica.

() Solder the leads to the foil and cut off the excess lead lengths.

Heathkit®

Refer to Pictorial 1-4 (Illustration Booklet, Page 5) for the following steps.

Install parts in Section 1 of the circuit board as follows:

NOTE: When you install each of the following transistors, position it so the flat side is over the outline of the flat on the circuit board. Then start the leads into the corresponding holes in the circuit board. Position the transistor 1/4" above the circuit board. Then solder the leads to the foil and cut off any excess lead lengths.

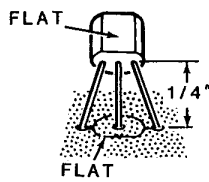

- Q101: 2N5770 transistor (#417-293).
- Q106: 2N3638A transistor (#417-234).
- Q105: MPF105 transistor (#417-169).
- Q102: MPF105 transistor (#417-169).

Install parts in Section 2 of the circuit board as follows:

Solder the leads of each part to the foil as you install it and cut off any excess lead lengths.

- L101: .3 μ H coil (#40-2076). Match the pins on the coil with their corresponding circuit board holes and push the coil down tight against the circuit board. The coil will only fit one way.

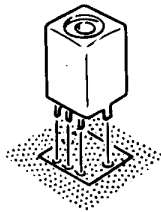

- L103: .44 μ H coil (#40-2075).

- Skip L105.

When you install the next two coils, be sure to match the tab on the coil with the outline of the tab on the circuit board.

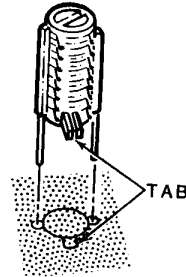

- L107: .14 μ F coil (violet, #40-1785).
- Skip L109.
- L112: .14 μ H coil (violet, #40-1785).
- Skip L114 and L116.
- Q103: MPSA20 transistor (#417-801).
- Q104: MPSA20 transistor (#417-801).

Install parts in Section 3 of the circuit board as follows. Solder the leads of each part to the foil as you install it and cut off any excess lead lengths.

- L102: .3 μ H coil (#40-2076).
- L104: .44 μ H coil (#40-2075).
- Skip L106.
- L108: .14 μ H coil (violet, #40-1785). Be sure to match the tab on the coil with the outline of the tab on the circuit board.
- Skip L111.
- L113: .14 μ H coil (violet, #40-1785).
- Skip L115 and L117.

- () Q107: MFE131 transistor (#417-863). Match the tab on the transistor with the outline of the tab on the circuit board. Then insert the leads into their corresponding holes, position the transistor 1/4" above the circuit board, and solder the leads to the foils. Cut off any excess lead lengths.

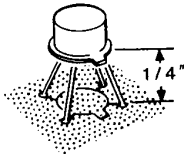

Install parts in Section 4 of the circuit board as follows. Solder the leads of each part to the foil as you install it and cut off any excess lead lengths.

- () L124: .3 μH coil (#40-2076).
- () L125: .3 μH coil (#40-2076).
- () Skip L126.
- () L127: .3 μH coil (#40-2076).
- () Skip L128.
- () L129: .3 μH coil (#40-2076).
- () Skip L131 and L132.
- () Q111: 2N5770 transistor (#417-293).
- () Q115: MPSA20 transistor (#417-801).
- () Q114: MPSA20 transistor (#417-801).

Install parts in Section 5 of the circuit board as follows. Solder the leads of each part to the foil as you install it and cut off any excess lead lengths.

- () L137: .44 μH coil (#40-2075).
- () Q113: MPSA20 transistor (#417-801).

Install parts in Section 6 of the circuit board as follows. Solder the leads of each part to the foil as you install it and cut off any excess lead lengths.

- () Q108: 2N5770 transistor (#417-293).

- () Q109: 2N5770 transistor (#417-293).
- () L135: 3 μH coil (#40-2070).
- () Q112: MPF105 transistor (#417-169).

Refer to Pictorial 1-5 (Illustration Booklet, Page 6) for the following steps.

Install parts in the circuit board as follows. Solder each part to the foil as you install it and cut off any excess lead lengths.

NOTE: When you install a control on the circuit board, start the lugs of the control into their circuit board holes and push the control down tight against the circuit board. Then solder the lugs to the foil.

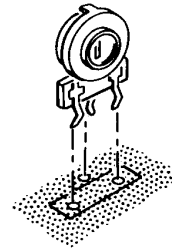

- () R131: 100 kΩ control (#10-941).
- () L118: 5.5 μH coil (#40-2111). Match the color dot near one lug of the coil with the dot mark on the circuit board and start the lugs into their corresponding holes. Push the coil down tight against the circuit board, solder the lugs to the foil, and cut off any excess lug lengths. NOTE: You may have to straighten the lugs on this coil to make it fit the circuit board holes.

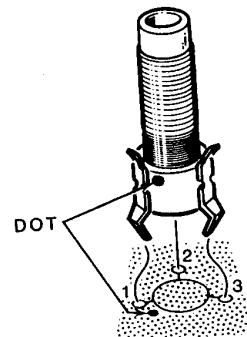

Heathkit®

() P101: 5-pin plug. Start the shorter pins into the circuit board holes. Then push the plug down tight against the circuit board and solder the pins to the foil.

() R173: 500 Ω control (#10-918).

NOTE: When you install a crystal, match the three leads with their corresponding holes in the circuit board. Then push the crystal down tight against the circuit board, solder the leads to the foil, and cut off the excess lead lengths.

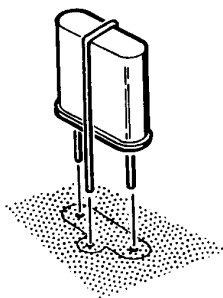

() Y101: 18.330 MHz crystal (#404-664).

() Y102: 21.830 MHz crystal (#404-665).

() Skip Y103.

() Y104: 28.830 MHz crystal (#404-667).

() Skip Y105.

() Y106: 35.830 MHz crystal (#404-669).

() Skip Y107 and Y108.

() Y109: 8.8314 MHz crystal (#404-639).

CIRCUIT BOARD CHECKOUT

Carefully inspect the foil side of the circuit board for the following most-commonly-made errors:

() Unsoldered connections. NOTE: There are several unused holes in the circuit board.

() Poor solder connections.

() Solder bridges between foil patterns (See Page 15).

() Protruding leads which could touch each other or the chassis when the circuit board is installed later.

Refer to the illustrations where parts were installed as you make the following visual checks:

() Transistors for the proper **type** and **installation**.

() Diodes for the proper **type** and **installation**.

Refer to Pictorial 1-6 for the following steps.

- () Position the oscillator shield as shown in Detail 1-6A. Then melt a bead of solder along one of the four corner seams in the shield.
- () Similarly, melt a bead of solder along the remaining three seams in the shield.
- () Start the lugs on the shield into their corresponding holes in the circuit board as shown in the Pictorial. Then push the shield down tight against the circuit board and solder the lugs to the foil.

Set the oscillator circuit board aside and proceed to "T/R Circuit Board."

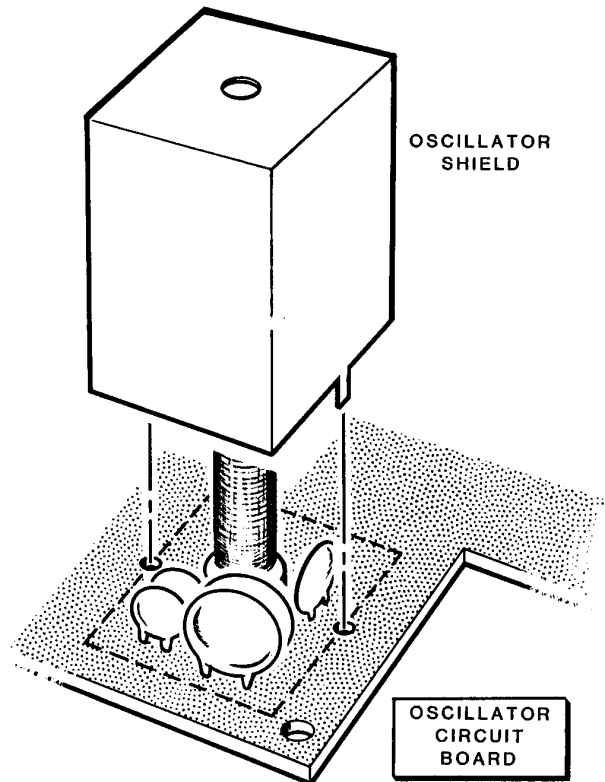

PICTORIAL 1-6

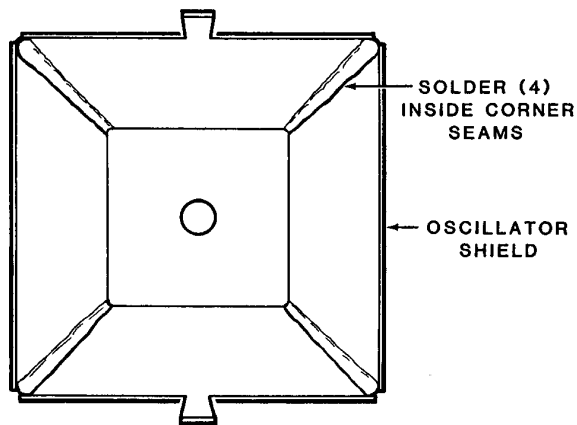

Detail 1-6A

T/R CIRCUIT BOARD

PARTS LIST

Remove the parts from Pack #2. Then check each part against the following list. Do not remove components that are supplied on a tape from the tape until you use them in a step. Return any part that is packed in an individual envelope, with the part number on it, back to the envelope after you identify it until that part is called for in a step. Do not throw away any packing material until all of the parts are accounted for.

To order a replacement part, always include the PART NUMBER. Use the Parts Order Form furnished with this kit. If a Parts Order Form is not available, refer to "Replacement Parts" inside the rear cover of this Manual. For prices, refer to the separate "Heath Parts Price List."

TAPED COMPONENTS

NOTE: These parts are taped on a strip which was checked before shipment. Since these parts are taped in the order of assembly, you may not wish to check them against the following list.

HEATH Part No.	QTY.	DESCRIPTION	CIRCUIT Comp. No.	HEATH Part No.	QTY.	DESCRIPTION	CIRCUIT Comp. No.
RESISTORS				Resistors (Cont'd)			
NOTE: The following resistors are rated at 1/4-watt and have a tolerance of 5% unless otherwise listed. A 5% tolerance is indicated by a fourth color band of gold.				6-101-12	7	100 Ω (brn-blk-brn)	R301, R341, R345, R346, R405, R406, R413
6-279-12	1	2.7 Ω (red-viol-gold)	R418	6-181-12	1	180 Ω (brn-gry-brn)	R444
6-220-12	2	22 Ω (red-red-blk)	R407, R415	6-221-12	3	220 Ω (red-red-brn)	R305, R311, R322
6-470-12	1	47 Ω (yel-viol-blk)	R339	6-331-12	1	330 Ω (org-org-brn)	R419
6-680-12	1	68 Ω (blu-gry-blk)	R324	6-471-12	1	470 Ω (yel-viol-brn)	R372
				6-681-12	3	680 Ω (blu-gry-brn)	R332, R417, R428

HEATH Part No.	QTY.	DESCRIPTION	CIRCUIT Comp. No.
Resistors (Cont'd)			
6-821-12	1	820 Ω (gry-red-brn)	R337
6-102-12	9	1000 Ω (brn-blk-red)	R334, R335, R336, R338, R347, R373, R414, R435, R436
6-122-12	1	1200 Ω (brn-red-red)	R342
6-152-12	1	1500 Ω (brn-grn-red)	R429
6-182-12	1	1800 Ω (brn-gry-red)	R308
6-222-12	3	2200 Ω (red-red-red)	R303, R423, R425
6-272-12	1	2700 Ω (red-viol-red)	R344
6-332-12	4	3300 Ω (org-org-red)	R369, R401, R402, R424
6-392-12	1	3900 Ω (org-wht-red)	R408
6-472-12	12	4700 Ω (yel-viol-red)	R307, R331, R364, R404 R412, R433, R434, R437, R438, R441, R442, R443
6-562-12	1	5600 Ω (grn-blu-red)	R304
6-682-12	2	6800 Ω (blu-gry-red)	R316, R325
6-752-12	1	7500 Ω (viol-grn-red)	R416
6-822-12	1	8200 Ω (gry-red-red)	R403
6-103-12	4	10 kΩ (brn-blk-org)	R343, R431, R439, R446
6-123-12	1	12 kΩ (brn-red-org)	R323
6-153-12	2	15 kΩ (brn-grn-org)	R348, R351
6-223-12	1	22 kΩ (red-red-org)	R371
6-273-12	2	27 kΩ (red-viol-org)	R314, R349
6-333-12	5	33 kΩ (org-org-org)	R306, R313, R353, R358, R409
6-473-12	3	47 kΩ (yel-viol-org)	R312, R328, R422
6-104-12	11	100 kΩ (brn-blk-yel)	R302, R309, R315, R321, R355, R356, R361, R362, R363, R365, R366
6-154-12	1	150 kΩ (brn-grn-yel)	R367
6-564-12	1	560 kΩ (grn-blu-yel)	R319
6-684-12	2	680 kΩ (blu-gry-yel)	R352, R357
6-105-12	2	1 MΩ (brn-blk-grn)	R326, R327
6-155-12	3	1.5 MΩ (brn-grn-grn)	R317, R354, R359
6-515	1	5.1 MΩ, 1/2-watt (grn-brn-grn)	R318

HEATH Part No.	QTY.	DESCRIPTION	CIRCUIT Comp. No.
CAPACITORS			
21-761	26	.01 μF (103) glass ceramic	C302, C304, C307, C311, C314, C315, C316, C321, C322, C323, C325, C338, C349, C353, C354, C358, C424, C425, C426, C432, C433, C441, C442, C443, C445, C579
21-762	9	.1 μF (104) glass ceramic	C331, C332, C351, C352, C355, C356, C361, C446, C569

DIODES

56-20	4	1N295A (red-wht-grn)	D307, D308, D309, D311
56-55	1	1N4753A	D405
56-56	11	1N4149	D303, D305, D306, D312, D401, D402, D403, D404, D406, D407, D408
56-646	2	BA-244 (red-yel-yel)	D301, D302
57-27	1	1N2071	D409

NON-TAPED PARTS

The following parts are not taped on strips. The key numbers correspond to the numbers on the "T/R Circuit Board Parts Pictorial" (Illustration Booklet, Page 7).

KEY No.	HEATH Part No.	QTY.	DESCRIPTION	CIRCUIT Comp. No.	KEY No.	HEATH Part No.	QTY.	DESCRIPTION	CIRCUIT Comp. No.
CAPACITORS					Electrolytic				
Mica									
A1	20-141	1	82 pF	C305	A3	25-922	3	.68 μ F	C571, C572, C575
A1	20-102	1	100 pF	C324	A3	25-923	1	1.5 μ F	C514
A1	20-178	2	160 pF	C562, C564	A3	25-924	4	2.2 μ F	C336, C346, C347, C435
A1	20-108	2	200 pF	C558, C561	A3	25-912	2	3.3 μ F	C317, C576
A1	20-126	1	255 pF	C563	A4	25-864	2	10 μ F, 25V	C319, C357
A1	20-139	1	330 pF	C559	A3	25-880	2	10 μ F, 35V	C427, C436
A1	20-106	2	390 pF	C552, C554	A3	25-927	2	22 μ F	C343, C577
A1	20-167	2	620 pF	C447, C551	A3	25-915	1	47 μ F	C578
A1	20-107	1	680 pF	C553	A3	25-948	2	100 μ F	C333, C342
A1	20-127	2	1300 pF	C448, C449	A3	25-942	1	220 μ F	C359
					A3	25-889	1	330 μ F	C444
Ceramic					INDUCTORS				
A2	21-702	2	5 pF	C415, C439	B1	40-2116	2	.55 μ H toroid coil	L441, L442
A2	21-703	1	6.8 pF	C408	B2	40-2073	2	.71 μ H coil	L412, L413
A2	21-3	2	10 pF	C309, C312	B1	40-2115	2	.9 μ H toroid coil	L438, L439
A2	21-770	1	12 pF	C402	B2	40-2072	2	.9 μ H coil	L407, L408
A2	21-111	1	15 pF	C301	B1	40-2113	2	1.8 μ H toroid coil	L434, L435
A2	21-60	1	18 pF	C318	B3	40-2112	3	3 μ H toroid coil	L431, L432, L433
A2	21-84	1	24 pF	C401	B2	40-2070	2	3 μ H coil	L403, L404
A2	21-75	2	100 pF (100K)	C329, C434	B4	40-2118	1	6.5 μ H toroid coil	T403
A2	21-788	2	110 pF (111)	C416, C417	B2	40-2069	2	13 μ H coil	L401, L402
A2	21-715	2	150 pF (151)	C409, C411	B5	45-73	1	2.2 μ H choke (red-red-gold)	L425
A2	21-746	2	180 pF (181)	C403, C404	B6	45-614	1	10 μ H choke (brn-blk-blk)	L426
A2	21-17	2	270 pF	C306, C568	B7	45-622	1	68 μ H choke (blu-gry-blk)	L304
A2	21-140	10	.001 μ F (1000 pF)	C308, C313, C326, C327, C328, C339, C341, C344, C345, C437	B7	45-621	15	100 μ H choke (brn-blk-brn)	L301, L302, L303, L305, L306, L307, L308, L418, L419, L421, L422, L423, L424, L427, L428
A2	21-164	1	.0015 μ F (1500 pF)	C438	B2	52-193	2	10.7 MHz transformer	T301, T302
A2	21-27	2	.005 μ F (5000 pF)	C334, C335	B8	404-640	1	8.830 MHz crystal filter	FL301
A2	21-143	2	.05 μ F	C429, C431					

KEY No.	HEATH Part No.	QTY.	DESCRIPTION	CIRCUIT Comp. No.
---------	----------------	------	-------------	-------------------

TRANSISTORS-INTEGRATED CIRCUITS (ICs)

NOTE: Transistors and integrated circuits may be marked for identification in any of the following four ways:

1. Part number.
2. Type number. (For integrated circuits, this refers only to the numbers and letters shown in **bold** print in the Parts List. Disregard any other numbers or letters on the IC.)
3. Part number and type number.
4. Part number with a type number other than the one listed.

C1	417-819	2	MJE171 transistor	Q408, Q409
C2	417-169	2	MPF105 transistor	Q301, Q302
C2	417-801	2	MPSA20 transistor	Q303, Q411
C2	417-865	1	MPSA55 transistor	Q403
C2	417-172	2	MPS6521 transistor	Q401, Q402
C3	417-912	2	MRF237 transistor	Q405, Q406
C2	417-201	2	X29A829 transistor	Q407, Q412
C3	417-205	1	2N3866 transistor	Q404
C4	442-715	1	CA3130 IC	U302
C4	442-602	1	LM324N IC	U304
C4	442-55	1	MC1349P IC	U301
C5	442-96	1	MC1496G IC	U303
C6	442-681	1	78L08 IC	U402
C4	442-734	1	LM388N-3 IC	U306

763

KEY No.	HEATH Part No.	QTY.	DESCRIPTION	CIRCUIT Comp. No.
---------	----------------	------	-------------	-------------------

HARDWARE

D1	250-1412	2	4-40 × 3/8" screw	
D2	252-2	2	4-40 nut	
D3	254-9	2	#4 lockwasher	

MISCELLANEOUS

E1	6-220-1	1	22 Ω, 1-watt (red-red-blk) resistor	R421
E2	10-222	1	50 kΩ control	R445
E2	10-946	1	500 kΩ control	R329
E2	10-318	2	2000 (2 k) Ω control	R333, R368
E3	63-1386	4	Rotary switch	SW401, SW4, SW403, SW4
	85-2957-1	1	T/R circuit board	
E4	150-72	1	Double-balanced mixer	U401
E5	215-45	2	Heat sink	
E6	206-1464	2	Band switch shield	
E7	206-1470	1	PA shield	
E8	432-134	1	Wire socket	
E9	434-230	2	8-pin IC socket	
E9	434-298	2	14-pin IC socket	
E10	453-345	1	7" shaft	
E11	475-10	3	1/8" × 1/4" ferrite bead	
E12	475-12	2	5/16" × 5/16" ferrite bead	
E13	475-15	2	1/8" × 1/8" ferrite bead	
E14	475-17	1	3/16" × 3/8" ferrite bead	
E15	475-24	2	Ferrite core	
E16	490-185	1	Package of desoldering braid	

STEP-BY-STEP ASSEMBLY

- () Refer to Pictorial 2-1 (Illustration Booklet, Page 8) for the following steps.
- () Position the T/R circuit board as shown in the Pictorial.

NOTE: Due to the density of this circuit board, You will first install the taped components that mount horizontally on the circuit board. When you have these installed, you will install the taped components that mount vertically.

Install a component in Section 1 of the circuit board as follows:

- () D406: 1N4149 diode (#56-56). Be sure to position the banded end as shown on the circuit board.
- () Solder the leads to the foil and cut off the excess lead lengths.

Install components in Section 2 of the circuit board as follows:

- () C446: .1 μ F (104) glass ceramic capacitor.
- () D405: 1N4753A diode (#56-55).
- () C424: .01 μ F (103) glass ceramic capacitor.
- () D401: 1N4149 diode (#56-56).
- () Solder the leads to the foil and cut off the excess lead lengths.

Install components in Section 3 of the circuit board as follows:

- () R334: 1000 Ω (brn-blk-red) resistor.
- () R428: 680 Ω (blu-gry-brn) resistor.
- () R429: 1500 Ω (brn-grn-red) resistor.
- () R418: 2.7 Ω (red-viol-gold) resistor.

- () C432: .01 μ F (103) glass ceramic capacitor.
- () C426: .01 μ F (103) glass ceramic capacitor.
- () R414: 1000 Ω (brn-blk-red) resistor.
- () C433: .01 μ F (103) glass ceramic capacitor.
- () C579: .01 μ F (103) glass ceramic capacitor.
- () Solder the leads to the foil and cut off the excess lead lengths.

Install components in Section 4 of the circuit board as follows:

- () R332: 680 Ω (blu-gry-brn) resistor.
- () R331: 4700 Ω (yel-viol-red) resistor.
- () D408: 1N4149 diode (#56-56).
- () R412: 4700 Ω (yel-viol-red) resistor.
- () D303: 1N4149 diode (#56-56).
- () Solder the leads to the foil and cut off the excess lead lengths.

Install components in Section 5 of the circuit board as follows:

- () R357: 680 k Ω (blu-gry-yel) resistor.
- () R313: 33 k Ω (org-org-org) resistor.
- () R346: 100 Ω (brn-blk-brn) resistor.
- () R438: 4700 Ω (yel-viol-red) resistor.
- () R437: 4700 Ω (yel-viol-red) resistor.
- () R433: 4700 Ω (yel-viol-red) resistor.
- () Solder the leads to the foil and cut off the excess lead lengths.

Install components in Section 6 of the circuit board as follows:

- () C351: .1 μ F (104) glass ceramic capacitor.
- () R352: 680 k Ω (blu-gry-yel) resistor.
- () R439: 10 k Ω (brn-blk-org) resistor.
- () D306: 1N4149 diode (#56-56).
- () R364: 4700 Ω (yel-viol-red) resistor.
- () R441: 4700 Ω (yel-viol-red) resistor.
- () R302: 100 k Ω (brn-blk-yel) resistor.
- () R305: 220 Ω (red-red-brn) resistor.
- () C311: .01 μ F (103) glass ceramic capacitor.
- () R307: 4700 Ω (yel-viol-red) resistor.
- () R308: 1800 Ω (brn-gry-red) resistor.
- () C354: .01 μ F (103) glass ceramic capacitor.
- () R369: 3300 Ω (org-org-red) resistor.
- () C353: .01 μ F (103) glass ceramic capacitor.
- () Solder the leads to the foil and cut off the excess lead lengths.

Install components in Section 7 of the circuit board as follows:

- () R318: 5.1 M Ω , 1/2-watt (grn-brn-grn) resistor.
- () R309: 100 k Ω (brn-blk-yel) resistor.
- () C322: .01 μ F (103) glass ceramic capacitor.
- () R316: 6800 Ω (blu-gry-red) resistor.
- () R372: 470 Ω (yel-viol-brn) resistor.

- () R371: 22 k Ω (red-red-org) resistor.
- () Solder the leads to the foil and cut off the excess lead lengths.

Install components in Section 8 of the circuit board as follows:

- () R338: 1000 Ω (brn-blk-red) resistor.
- () R336: 1000 Ω (brn-blk-red) resistor.
- () R335: 1000 Ω (brn-blk-red) resistor.
- () R337: 820 Ω (gry-red-brn) resistor.
- () R343: 10 k Ω (brn-blk-org) resistor.
- () R344: 2700 Ω (red-viol-red) resistor.
- () C332: .1 μ F (104) glass ceramic capacitor.
- () D308: 1N295A diode (red-wht-grn, #56-20).
- () D309: 1N295A diode (red-wht-grn, #56-20).
- () D311: 1N295A diode (red-wht-grn, #56-20).
- () C321: .01 μ F (103) glass ceramic capacitor.
- () C323: .01 μ F (103) glass ceramic capacitor.
- () C325: .01 μ F (103) glass ceramic capacitor.
- () R325: 6800 Ω (blu-gry-red) resistor.
- () R317: 1.5 M Ω (brn-grn-grn) resistor.
- () C355: .1 μ F (104) glass ceramic capacitor.
- () C361: .1 μ F (104) glass ceramic capacitor.
- () Solder the leads to the foil and cut off the excess lead lengths.

Heathkit®

Refer to Pictorial 2-2 (Illustration Booklet, Page 9) for the following steps.

NOTE: Be sure to install the following parts vertically on the circuit board (like you did when you assembled the oscillator circuit board).

Install components in Section 1 of the circuit board as follows:

- R425: 2200 Ω (red-red-red) resistor.
- C443: .01 μF (103) glass ceramic capacitor.
- R424: 3300 Ω (org-org-red) resistor.
- D407: 1N4149 diode (#56-56). Be sure to position the banded end up.
- C442: .01 μF (103) glass ceramic capacitor.
- C441: .01 μF (103) glass ceramic capacitor.
- D404: 1N4149 diode (#56-56).
- R422: 47 k Ω (yel-viol-org) resistor.
- D403: 1N4149 diode (#56-56).
- R423: 2200 Ω (red-red-red) resistor.
- Solder the leads to the foil and cut off the excess lead lengths.

Install components in Section 2 of the circuit board as follows:

- C445: .01 μF (103) glass ceramic capacitor.
- R401: 3300 Ω (org-org-red) resistor.
- Solder the leads to the foil and cut off the excess lead lengths.

Install components in Section 3 of the circuit board as follows:

- R419: 330 Ω (org-org-brn) resistor.
- C425: .01 μF (103) glass ceramic capacitor.
- R402: 3300 Ω (org-org-red) resistor.

- R404: 4700 Ω (yel-viol-red) resistor.
- Solder the leads to the foil and cut off the excess lead lengths.

Install components in Section 4 of the circuit board as follows:

- C569: .1 μF (104) glass ceramic capacitor.
- R417: 680 Ω (blu-gry-brn) resistor.
- R416: 7500 Ω (viol-grn-red) resistor.
- D402: 1N4149 diode (#56-56).
- R406: 100 Ω (brn-blk-brn) resistor.
- R415: 22 Ω (red-red-blk) resistor.
- R403: 8200 Ω (gry-red-red) resistor.
- R408: 3900 Ω (org-wht-red) resistor.
- R407: 22 Ω (red-red-blk) resistor.
- Solder the leads to the foil and cut off the excess lead lengths.

Install components in Section 5 of the circuit board as follows:

- R323: 12 k Ω (brn-red-org) resistor.
- R315: 100 k Ω (brn-blk-yel) resistor.
- R358: 33 k Ω (org-org-org) resistor.
- R314: 27 k Ω (red-viol-org) resistor.
- R322: 220 Ω (red-red-brn) resistor.
- R431: 10 k Ω (brn-blk-org) resistor.
- D409: 1N2071 diode (#57-27).
- R409: 33 k Ω (org-org-org) resistor.
- R405: 100 Ω (brn-blk-brn) resistor.
- R413: 100 Ω (brn-blk-brn) resistor.
- Solder the leads to the foil and cut off the excess lead lengths.

Install components in Section 6 of the circuit board as follows:

- () R444: 180 Ω (brn-gry-brn) resistor.
- () R446: 10 k Ω (brn-blk-org) resistor.
- () R443: 4700 Ω (yel-viol-red) resistor.
- () R435: 1000 Ω (brn-blk-red) resistor.
- () R434: 4700 Ω (yel-viol-red) resistor.
- () R303: 2200 Ω (red-red-red) resistor.
- () C304: .01 μ F (103) glass ceramic capacitor.
- () Solder the leads to the foil and cut off the excess lead lengths.

Install components in Section 7 of the circuit board as follows:

- () R356: 100 k Ω (brn-blk-yel) resistor.
- () R359: 1.5 M Ω (brn-grn-grn) resistor.
- () R354: 1.5 M Ω (brn-grn-grn) resistor.
- () R355: 100 k Ω (brn-blk-yel) resistor.
- () R442: 4700 Ω (yel-viol-red) resistor.
- () R353: 33 k Ω (org-org-org) resistor.
- () R304: 5600 Ω (grn-blu-red) resistor.
- () R436: 1000 Ω (brn-blk-red) resistor.
- () C307: .01 μ F (103) glass ceramic capacitor.
- () R306: 33 k Ω (org-org-org) resistor.
- () D302: BA-244 diode (red-yel-yel, #56-646).
- () D301: BA-244 diode (red-yel-yel, #56-646).
- () C302: .01 μ F (103) glass ceramic capacitor.
- () R301: 100 Ω (brn-blk-brn) resistor.
- () Solder the leads to the foil and cut off the excess lead lengths.

Install components in Section 8 of the circuit board as follows:

- () C349: .01 μ F (103) glass ceramic capacitor.
- () R367: 150 k Ω (brn-grn-yel) resistor.
- () D312: 1N4149 diode (#56-56).
- () R365: 100 k Ω (brn-blk-yel) resistor.
- () R366: 100 k Ω (brn-blk-yel) resistor.
- () R349: 27 k Ω (red-viol-org) resistor.
- () C352: .1 μ F (104) glass ceramic capacitor.
- () C338: .01 μ F (103) glass ceramic capacitor.
- () R348: 15 k Ω (brn-grn-org) resistor.
- () R351: 15 k Ω (brn-grn-org) resistor.
- () R361: 100 k Ω (brn-blk-yel) resistor.
- () R362: 100 k Ω (brn-blk-yel) resistor.
- () R363: 100 k Ω (brn-blk-yel) resistor.
- () R312: 47 k Ω (yel-viol-org) resistor.
- () D305: 1N4149 diode (#56-56).
- () R311: 220 Ω (red-red-brn) resistor.
- () C316: .01 μ F (103) glass ceramic capacitor.
- () Solder the leads to the foil and cut off the excess lead lengths.

Install components in Section 9 of the circuit board as follows:

- () C358: .01 μ F (103) glass ceramic capacitor.
- () R347: 1000 Ω (brn-blk-red) resistor.
- () R341: 100 Ω (brn-blk-brn) resistor.
- () R319: 560 k Ω (grn-blu-yel) resistor.

Heathkit®

- () R321: 100 k Ω (brn-blk-yel) resistor.
- () R328: 47 k Ω (yel-viol-org) resistor.
- () R326: 1 M Ω (brn-blk-grn) resistor.
- () D307: 1N295A diode (red-wht-grn, #56-20).
- () R327: 1 M Ω (brn-blk-grn) resistor.
- () R324: 68 Ω (blu-gry-blk) resistor.
- () C314: .01 μ F (103) glass ceramic capacitor.
- () C315: .01 μ F (103) glass ceramic capacitor.
- () R373: 1000 Ω (brn-blk-red) resistor.
- () C356: .1 μ F (104) glass ceramic capacitor.
- () Solder the leads to the foil and cut off the excess lead lengths.
- Install components in Section 10 of the circuit board as follows:
- () C331: .1 μ F (104) glass ceramic capacitor.
- () R339: 47 Ω (yel-viol-blk) resistor.
- () R342: 1200 Ω (brn-red-red) resistor.
- () R345: 100 Ω (brn-blk-brn) resistor.
- () Solder the leads to the foil and cut off the excess lead lengths.
- Refer to Pictorial 2-3 (Illustration Booklet, Page 10) for the following steps.
- Install parts in Section 1 of the circuit board as follows:
- () L428: 100 μ H (brn-blk-brn, #45-621) choke.
- () W417: 1-1/8" violet solid wire.
- () L427: 100 μ H (brn-blk-brn, #45-621) choke.
- () L426: 10 μ H (brn-blk-blk, #45-614) choke.
- () L419: 100 μ H (brn-blk-brn, #45-621) choke.
- () W411: 1-3/8" violet solid wire.
- () Skip W408 and W407.
- () W406: 1-1/2" violet solid wire.
- () Skip W405.
- () W404: 1-1/2" violet solid wire.
- () Solder the leads to the foil and cut off the excess lead lengths.
- Install parts in Section 2 of the circuit board as follows:
- () W414: 7/8" small bare wire.
- () W415: 1-5/8" violet solid wire.
- () L425: 2.2 μ H (red-red-gold, #45-73) choke.
- () L424: 100 μ H (brn-blk-brn, #45-621) choke.
- () Wire socket at TP.
- () Two 1/8" \times 1/4" ferrite beads (and a 1" small bare wire) at FB-FB.
- () L421: 100 μ H (brn-blk-brn, #45-621) choke.
- () Skip W403.
- () W402: 1-3/8" violet solid wire.
- () W401: 1" violet solid wire.
- () Solder the leads to the foil and cut off the excess lead lengths.
- Install parts in Section 3 of the circuit board as follows:
- () R421: 22 Ω , **1-watt** (red-red-blk) resistor.
- () 1/8" \times 1/4" ferrite bead at FB.
- () L422: 100 μ H (brn-blk-brn, #45-621) choke.

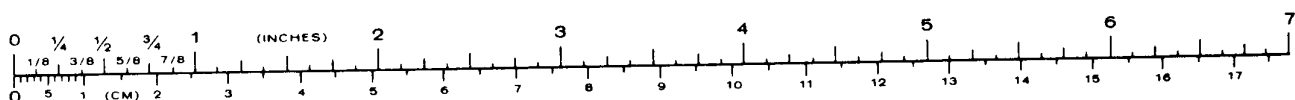

- () L418: 100 μ H (brn-blk-brn, #45-621) choke.
- () L423: 100 μ H (brn-blk-brn, #45-621) choke.
- () W409: 1" violet solid wire.
- () Solder the leads to the foil and cut off the excess lead lengths.

Install parts in Section 4 of the circuit board as follows:

- () W421: 1" violet solid wire.
- () L303: 100 μ H (brn-blk-brn, #45-621) choke.
- () L302: 100 μ H (brn-blk-brn, #45-621) choke.
- () Solder the leads to the foil and cut off the excess lead lengths.

Install parts in Section 5 of the circuit board as follows:

NOTES:

1. In some of the following steps, you will be directed to install an IC socket. First, make sure the pins are straight. Then start the pins into the circuit board holes. The index mark on the circuit board must still be visible after you install the socket. Solder the pins to the foil as you install each socket.

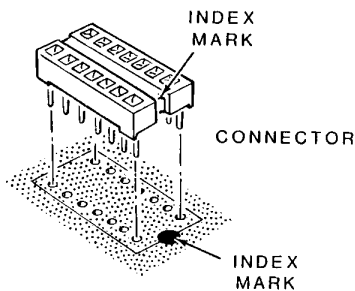

2. It is very easy to form a solder bridge between foils when you install an IC socket. After you install each socket, carefully inspect the foil for solder bridges and remove any that you find, as described below. If you suspect that you have a solder bridge, but are not positive, you can check your foil pattern against the

one shown in the corresponding "X-Ray View" (Illustration Booklet, Page 37).

To remove a solder bridge, hold the circuit board component-side-up as shown and hold your soldering iron tip between the two points that are bridged. The solder will flow down the soldering iron tip.

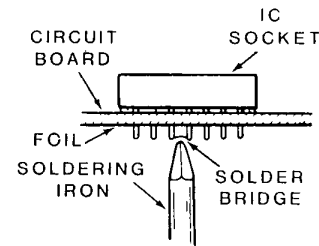

- () Install a 14-pin IC socket at U304.
- () W422: 1-1/4" violet solid wire.
- () L301: 100 μ H (brn-blk-brn, #45-621) choke.
- () W302: 3/4" small bare wire.
- () L305: 100 μ H (brn-blk-brn, #45-621) choke.
- () L304: 68 μ H (blu-gry-blk, #45-622) choke.
- () Solder the leads to the foil and cut off the excess lead lengths.

Install parts in Section 6 of the circuit board as follows.

- () W303: 1-3/4" violet solid wire.
- () 8-pin IC socket at U302.
- () L307: 100 μ H (brn-blk-brn, #45-621) choke.
- () L308: 100 μ H (brn-blk-brn, #45-621) choke.
- () 8-pin IC socket at U301.
- () L306: 100 μ H (brn-blk-brn, #45-621) choke.
- () 14-pin IC socket at U306.
- () Solder the leads to the foil and cut off the excess lead lengths.

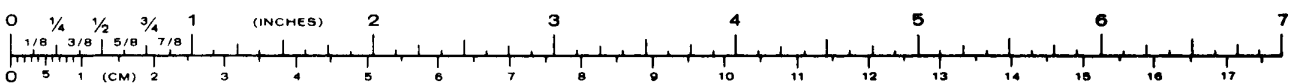

Heathkit®

Refer to Pictorial 2-4 (Illustration Booklet, Page 11) for the following steps.

NOTE: Solder the leads of each of the following parts to the foil and cut off any excess lead lengths as you install it.

Install parts in Section 1 of the circuit board as follows.

- () Q405: MRF237 transistor (#417-912). Be sure to match the lead spacing on the transistor with the hole spacing on the circuit board (when you have the transistor properly installed, its tab will be positioned as shown on the Pictorial). Mount this transistor down against the circuit board.
- () Q406: MRF237 transistor (#417-912). Mount this transistor down against the circuit board.

Install parts in Section 2 of the circuit board as follows:

- () Q404: 2N3866 transistor (#417-205). Mount this transistor down against the circuit board.

NOTE: Mount the following transistors 1/4" above the circuit board.

- () Q403: MPSA55 transistor (#417-865). Be sure to match the flat on the transistor with the flat part of the outline on the circuit board.
- () Q401: MPS6521 transistor (#417-172) and 1/8" × 1/8" ferrite bead. Slide the ferrite bead onto the base lead (center lead) as shown below before you install this transistor.

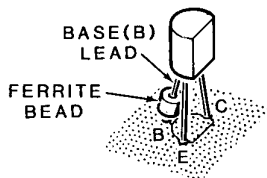

- () Q402: MPSA6521 transistor (#417-172) and 1/8" × 1/8" ferrite bead. Slide the bead onto the base lead (center lead) before you install this transistor.

Install parts in Section 3 of the circuit board as follows:

- () Q302: MPF105 transistor (#417-169).
- () Q412: X29A829 transistor (#417-201).
- () U402: **78L08** integrated circuit (#442-681). Install this IC the same as you install transistors.
- () Q411: MPSA20 transistor (#417-801).
- () Q409: MJE171 transistor (#417-819). Match the metal side of the transistor with the double line on the circuit board. Start the transistor leads into their corresponding circuit board holes and push the transistor down until the wider part of the leads touch the circuit board. Then solder the leads to the foil and cut off any excess lead lengths.

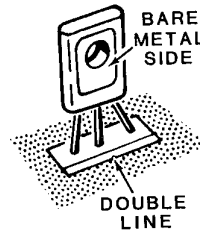

- () Q407: X29A829 transistor (#417-201).
- () Q408: MJE171 transistor (#417-819). Be sure to match the metal side of the transistor with the double line on the circuit board.

Install parts in Section 4 of the circuit board as follows:

- () Q301: MPF105 transistor (#417-169).
- () Q303: MPSA20 transistor (#417-801).

Install part in Section 5 of the circuit board as follows:

- () U303: MC1496G integrated circuit (#442-96). Be sure to match the tab on this IC with the tab shown on the circuit board outline. Then start the leads into their corresponding circuit board holes. Position the IC 1/4" above the circuit board before you solder the leads to the foil.

Refer to Pictorial 2-5 (Illustration Booklet, Page 12) for the following steps.

Install capacitors in Section 1 of the circuit board as follows:

- Skip C567.
- C564: 160 pF mica.
- C561: 200 pF mica.
- Skip C557.
- C554: 390 pF mica.
- C551: 620 pF mica.
- C568: 270 pF ceramic.
- Skip C566.
- C563: 255 pF mica.
- C559: 330 pF mica.
- Skip C556.
- C553: 680 pF mica.
- Skip C565.
- C562: 160 pF mica.
- C558: 200 pF mica.
- Skip C555.
- C552: 390 pF mica.
- Solder the leads to the foil and cut off the excess lead lengths.

Install capacitors in Section 2 of the circuit board as follows:

- C439: 5 pF ceramic.
- C437: .001 μ F (1000 pF) ceramic.
- C431: .05 μ F ceramic.

- Solder the leads to the foil and cut off the excess lead lengths.

Install capacitors in Section 3 of the circuit board as follows:

- Skip C421 and C418.
- C415: 5 pF ceramic.
- C417: 110 pF (111) ceramic.
- Skip C412 and C414.
- C408: 6.8 pF ceramic.
- C411: 150 pF (151) ceramic. Form the leads of this capacitor to fit the circuit board holes.
- Skip C405 and C407.
- C402: 12 pF ceramic.
- C404: 180 pF (181) ceramic.
- Skip C423, C422, C420, and C419.
- C416: 110 pF (111) ceramic.
- Skip C413.
- C409: 150 pF (151) ceramic. Form the leads of this capacitor to fit the circuit board holes.
- Skip C406.
- C403: 180 pF (181) ceramic.
- C401: 24 pF ceramic.
- Solder the leads to the foil and cut off the excess lead lengths.

Install capacitors in Section 4 of the circuit board as follows:

- C449: 1300 pF mica. NOTE: Use the circuit board holes that best fit the capacitor you were supplied.
- C448: 1300 pF mica. NOTE: Use the circuit board holes that best fit the capacitor you were supplied.

- () C447: 620 pF mica.
- () C438: .0015 μ F (1500 pF) ceramic.
- () C434: 100 pF (100K) ceramic.
- () C429: .05 μ F ceramic.
- () Solder the leads to the foil and cut off the excess lead lengths.

Install capacitors in Section 5 of the circuit board as follows:

- () C345: .001 μ F (1000 pF) ceramic.
- () C344: .001 μ F (1000 pF) ceramic.
- () C339: .001 μ F (1000 pF) ceramic.
- () C341: .001 μ F (1000 pF) ceramic.
- () C306: 270 pF ceramic.
- () C308: .001 μ F (1000 pF) ceramic.
- () C301: 15 pF ceramic.
- () C305: 82 pF mica.
- () C309: 10 pF ceramic.
- () Solder the leads to the foil and cut off the excess lead lengths.

Install capacitors in Section 6 of the circuit board as follows:

- () C335: .005 μ F (5000 pF) ceramic.
- () C334: .005 μ F (5000 pF) ceramic.
- () C329: 100 pF (100K) **ceramic**.
- () C318: 18 pF ceramic.
- () C326: .001 μ F (1000 pF) ceramic.
- () Solder the leads to the foil and cut off the excess lead lengths.

Install capacitors in Section 7 of the circuit board as follows:

- () C328: .001 μ F (1000 pF) ceramic.
- () C327: .001 μ F (1000 pF) ceramic.
- () C313: .001 μ F (1000 pF) ceramic.
- () C312: 10 pF ceramic.
- () C324: 100 pF **mica**.
- () Solder the leads to the foil and cut off the excess lead lengths.

Refer to Pictorial 2-6 (Illustration Booklet, Page 13) for the following steps.

NOTE: Solder the lugs or leads on the following parts to the foil and cut off any excess lead lengths as you install each part.

Install parts in Section 1 of the circuit board as follows:

NOTE: When you install a toroid coil, as in the next step, position the coil down against the circuit board as shown.

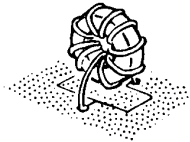

- () Skip L444.
- () L442: .55 μ H toroid coil (#40-2116).
- () L439: .9 μ H toroid coil (#40-2115).
- () Skip L437 and L443.
- () L441: .55 μ H toroid coil (#40-2116).
- () L438: .9 μ H toroid coil (#40-2115).
- () Skip L436.

- () T403: 6.5 μ H toroid coil (#40-2118). Be sure the twisted pair of leads go into the hole that is inside the outline on the circuit board (labeled 3,4), and the single leads go into holes 1 and 2 as shown.

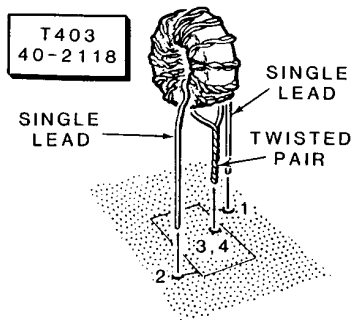

- () Skip L415.
 () L413: .71 μ H coil (#40-2073).
 () Skip L411.
 () L408: .9 μ H coil (#40-2072).
 () Skip L417, L416, and L414.
 () L412: .71 μ H coil (#40-2073).
 () Skip L409.
 () L407: .9 μ H coil (#40-2072).

Install parts in Section 2 of the circuit board as follows:

- () L433: 3 μ H toroid coil (#40-2112).
 () L435: 1.8 μ H toroid coil (#40-2113).
 () L434: 1.8 μ H toroid coil (#40-2113).
 () L432: 3 μ H toroid coil (#40-2112).
 () L431: 3 μ H toroid coil (#40-2112).

- () Install two 5/16" \times 5/16" ferrite beads on a 1-1/2" large bare wire at FB-FB. Use pliers to bend the wire to fit the circuit board holes.
 () Skip L406.
 () L404: 3 μ H coil (#40-2070).
 () L402: 13 μ H coil (#40-2069).
 () Skip L405.
 () L403: 3 μ H coil (#40-2070).
 () Skip T401.
 () L401: 13 μ H coil (#40-2069).

Install parts in Section 3 of the circuit board as follows:

- () U401: Double-balanced mixer (#150-72). Be sure pin 1 (marked with a blue dot) goes into hole 1 in the circuit board as shown on the Pictorial.

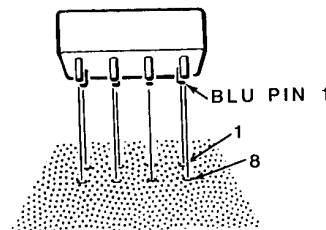

- () T301: 10.7 MHz transformer (#52-193).

Install parts in Section 4 of the circuit board as follows:

- () FL301: 8.830 MHz crystal filter (#404-640). NOTE: Disregard any In and Out printing that may be on your filter. The filter can be installed either way in the circuit board.
 () T302: 10.7 MHz transformer (#52-193).

Heathkit®

Refer to Pictorial 2-7 (Illustration Booklet, Page 14) for the following steps.

() Refer to Detail 2-7A (Illustration Booklet, Page 15) and use the following procedure to prepare a transformer:

1. Cut a 3" length of desoldering braid. Flatten this desoldering braid to be sure there are no twists in it.
2. Cut a 10" length of small violet solid wire. Then remove 1/8" of insulation from **one end**.
3. Refer to Part A of the Detail and solder the bare end of the violet wire to the side of, and 1" away from, one end of the desoldering braid. Then bend the desoldering braid in half as shown.
4. Refer to Part B of the Detail and insert the ends of the desoldering braid through the holes in a ferrite core. The solder connection for the violet wire should be at the left end of the indicated hole in the ferrite core.
5. Push a round rod (drill bit, etc.) of the largest possible diameter (about 1/8") all the way through into (but not clear through) both holes in the ferrite core to compress the desoldering braid flat against the sides of the web (center) of the ferrite core. Then remove the rod.

NOTE: As you proceed with the winding of this transformer, **continuously push each wire against the web of the ferrite core**. If you do not do this, you will not be able to complete all 6 wraps. Use progressively smaller rods. You can use the large bare wire supplied with this kit to push the last two turns against the ferrite core.

6. Refer again to Part B of the Detail and proceed with the winding of the transformer. Wrap the violet wire around the web (through both holes) of the ferrite core.

7. Refer to Part C of the Detail and finish wrapping the 6 wraps of violet wire (5 wires at the bottom and 6 wires at the top) on the ferrite core. When you complete the 6 wraps, there should not be enough violet wire left to make another complete wrap.

8. Refer again to Part C of the Detail and remove all but 1/8" of insulation from the end of the violet wire at the bottom of the ferrite core. Set the completed transformer aside temporarily.

() Use the same procedure to make another transformer identical to the one you just completed. Set the completed transformer aside temporarily.

() T404: Install one of the prepared transformers in the circuit board at T404. Start the leads of the transformer into their corresponding circuit board holes as shown in Detail 2-7B (Illustration Booklet, Page 15). Then position the transformer down against the circuit board and solder the desoldering braid and wires to the foil. Use only as much heat as necessary to insure a good connection. Cut off any excess braid or wire lengths.

() T401: Similarly, install the remaining prepared transformer in the circuit board at T401.

() Refer to Detail 2-7C (Illustration Booklet, Page 15) and use the following procedure to prepare transformer T402:

1. Cut an 8" length of violet solid wire and a 4" length of black solid wire. Do not remove any insulation from the ends of these wires yet.
2. Refer to Part A of the Detail and push one end of the prepared violet wire through the 3/16" × 3/8" ferrite bead until it extends 1" from the bead. Then wind seven turns of wire around the bead. Be sure to pull each turn tight against the bead. Also be sure each turn of the wire does not cross another turn.



3. Refer to Part B of the Detail and push one end of the black wire through the bead until it extends 1" from the bead and is next to one end of the violet wire. Then wind three turns of wire around the bead so they are between the turns of the violet wire.
4. Refer again to Part B of the Detail and cut off the excess ends of wire so they extend 1/2" away from where they exit the core. Then remove 1/4" of insulation from each wire end.

- () T402: Install the prepared transformer in the circuit board at T402. Be sure the black wires go into circuit board holes 3 and 4 and the violet wires go into holes 1 and 2. Then position the transformer down against the circuit board and solder the wires to the foil. Cut off any excess wire lengths.

NOTE: In some of the following steps, you will install electrolytic capacitors. Before you install an electrolytic capacitor, look at it and identify the leads. One lead will have a positive (+) mark or a negative (-) mark near it. Be sure to install the positive lead in the positive-marked hole, or the negative lead in the negative-marked hole.

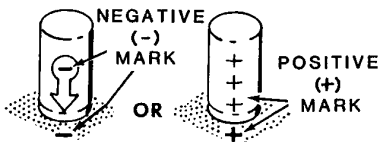

- () C436: 10 μ F, 35 V electrolytic capacitor. Be sure to observe the correct polarity. NOTE: Electrolytic capacitors are identified on the circuit board by the following outline:

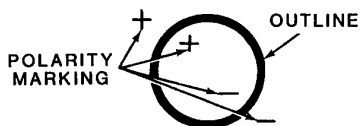

- () Solder the leads to the foil and cut off the excess lead lengths.

Install parts in Section 2 of the circuit board as follows.

- () R333: 2000 (2 k) Ω control (#10-318).

- () R445: 50 k Ω control (#10-222).

- () C444: 330 μ F electrolytic capacitor.

- () C578: 47 μ F electrolytic capacitor.

- () C571: .68 μ F electrolytic capacitor.

- () C572: .68 μ F electrolytic capacitor.

- () C435: 2.2 μ F electrolytic capacitor.

- () C427: 10 μ F, 35 V electrolytic capacitor.

- () C514: 1.5 μ F electrolytic capacitor.

- () Solder the leads to the foil and cut off the excess leads lengths.

Install electrolytic capacitors in Section 3 of the circuit board as follows.

- () C346: 2.2 μ F.

- () C343: 22 μ F.

- () C347: 2.2 μ F.

- () C342: 100 μ F.

- () C575: .68 μ F.

- () C577: 22 μ F.

- () C317: 3.3 μ F.

- () C576: 3.3 μ F.

- () Solder the leads to the foil and cut off the excess lead lengths.

Heathkit®

Install parts in Section 4 of the circuit board as follows:

- () R368: 2000 (2 k) Ω control (#10-318).
- () C336: 2.2 μ F electrolytic capacitor.
- () C333: 100 μ F electrolytic capacitor.
- () R329: 500 k Ω control (#10-946).
- () C319: 10 μ F, 25 V electrolytic capacitor.
- () C357: 10 μ F, 25 V electrolytic capacitor.
- () C359: 220 μ F electrolytic capacitor.
- () Solder the leads to the foil and cut off the excess lead lengths.

Refer to Pictorial 2-8 (Illustration Booklet, Page 16) for the following steps.

- () Prepare the following violet solid wires. These wires are listed in the order in which you will use them.

5"	6-3/4"
3"	7/8"
1-3/4"	2"
1-7/8"	1-1/2"
3-1/2"	5-1/4"

Install the prepared wires in the circuit board as follows. Be sure to position each wire as shown in the Pictorial.

- () 5" from hole A to hole A.
- () 3" from hole B to hole B.

- () 1-3/4" from hole L to hole L. Be sure to route this wire under the leads coming from R431 and D409 as shown.
- () 1-7/8" from hole D to hole D.
- () 3-1/2" from hole C to hole C.
- () 6-3/4" from hole E to hole E. Be sure to route this wire under the lead coming from D409 as shown.
- () 7/8" from hole K to hole K.
- () 2" from hole J to hole J. Be sure to route this wire under the lead coming from R348 as shown.
- () 1-1/2" from hole F to hole F.
- () W304: 5-1/4" wire.
- () Solder the leads to the foil and cut off the excess lead lengths.
- () Push a heat sink onto transistor Q405 as shown below.

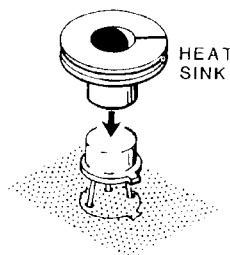

- () Similarly, push a heat sink onto transistor Q406.

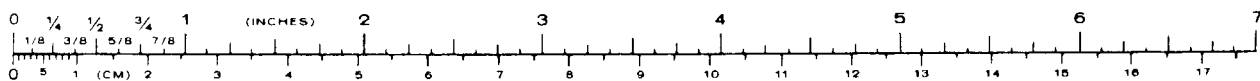

NOTE: Many of the ICs used in this kit are CMOS (complementary metal-oxide semiconductor) devices. These are rugged and reliable components when they are installed, but they can be damaged by static electricity during installation. The other ICs are of a type that is not susceptible to static electricity. Nevertheless, you should treat these ICs as if they were CMOS types, since it will avoid all possible confusion between ICs and provide protection in all cases. Use the procedure shown in Detail 2-8A whenever you are directed to install ICs.

- () U304: LM324N integrated circuit (#442-602).
- () U302: CA3130E integrated circuit (#442-715).
- () U301: MC1349P integrated circuit (#442-55).
- () U306: LM388N-3 integrated circuit (#442-763).

Once you remove a protected IC from its protective foam packing, DO NOT lay the IC down or let go of it until it is installed in its socket. When you bend the leads of a protected IC, hold the IC in one hand and place your other hand on your work surface before you touch the IC to your work surface. This will equalize the static electricity between the work surface and the IC.

The pins on the IC's may be bent out at an angle, so they do not line up with the holes in the IC socket. DO NOT try to install an IC without first bending the pins as described below. To do so may damage the IC pins or the socket, causing intermittent contact.

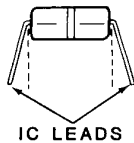

Before you install an IC, lay it down on its side as shown below and very carefully roll it toward the pins to bend the lower pins into line. Then turn the IC over and bend the pins on the other side in the same manner.

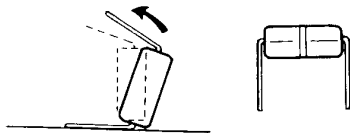

Compare the IC to the drawing shown below. Then determine which end of the IC is the pin 1 end.

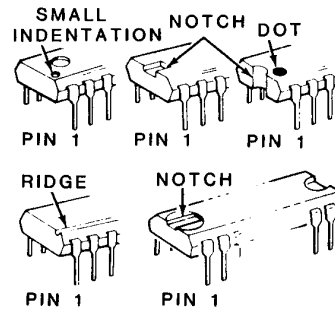

Position the pin 1 end of the IC over the index mark on the circuit board. Then start the IC pins into the socket. Make sure that all of the pins are started into the socket. Then push the IC firmly into the socket. NOTE: An IC pin can become bent under the IC and it will appear as though it is correctly installed in the socket.

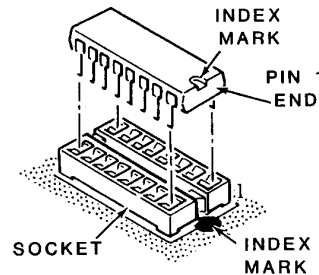

Detail 2-8A

Heathkit®

Refer to Pictorial 2-9 (Illustration Booklet, Page 17) for the following steps.

NOTE: Solder the following cables or parts to the foil as you install them.

- () Refer to Detail 2-9A and prepare the following shielded cables:

2-3/4"

8-1/2"

- () Connect one end of the 2-3/4" shielded cable to the circuit board as follows:

Inner lead to hole RF (near L401)

Shield wires to nearby hole GND

- () Connect the free end of the 2-3/4" shielded cable to the circuit board as follows:

Inner lead to hole RF (near U401)

Shield wires to nearby hole GND

- () Connect one end of the 8-1/2" shielded cable to the circuit board as follows:

Inner lead to hole SIDE TONE/IN

Shield wires to nearby hole GND

- () Connect the free end of the 8-1/2" shielded cable to the circuit board as follows:

Inner lead to hole SIDE TONE/OUT

Shield wires to nearby hole GND

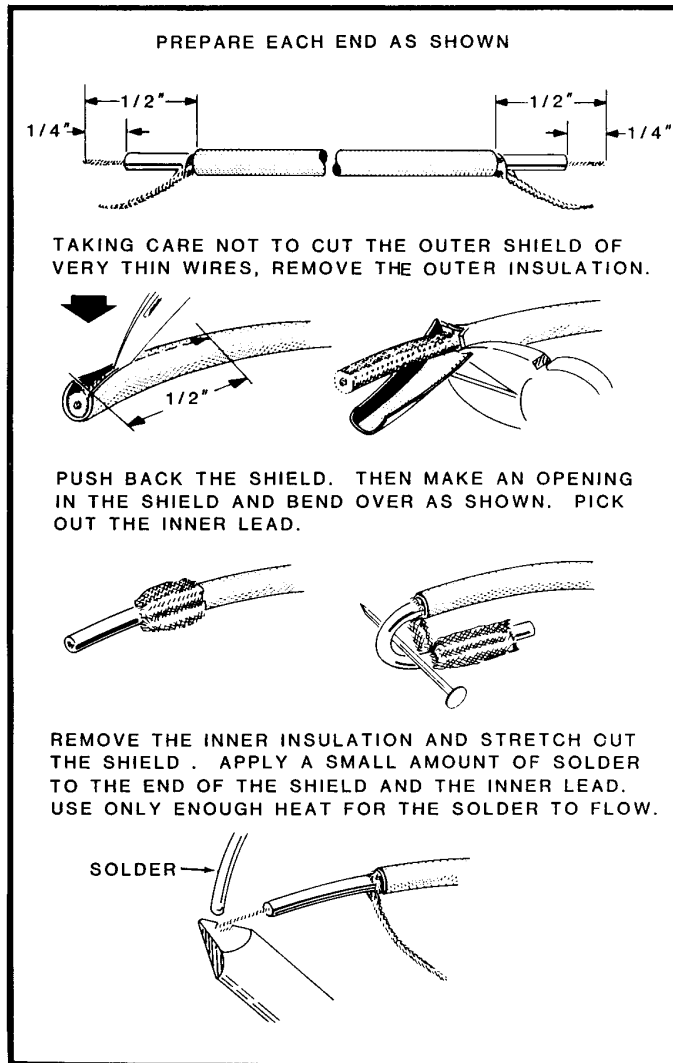

Detail 2-9A

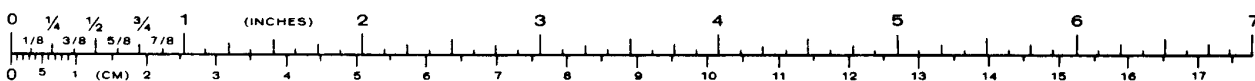

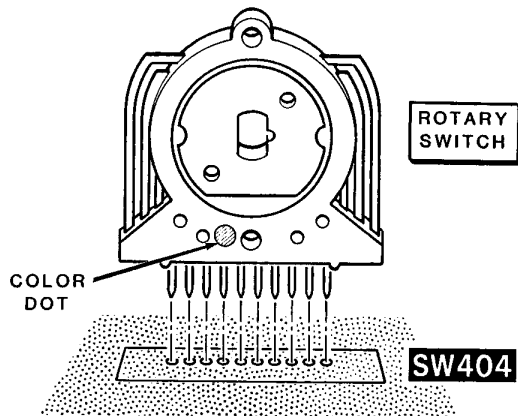

Detail 2-9B

- () SW404: Refer to Detail 2-9B and install a rotary switch at SW404 on the circuit board. **Position the switch so the side with the color dot is positioned as shown in the Pictorial.** Be sure all of the pins are in their circuit board holes. Then solder one of the center pins to the foil. Again make sure the switch is tight against and perpendicular to the circuit board; then solder the remaining pins to the foil.
- () SW403, SW402, & SW401: Similarly, install rotary switches at SW403, SW402, and SW401 on the circuit board. Make sure the color dot on each switch is positioned as shown in the Pictorial.

NOTE: When you install the shields in the following steps, be careful not to pinch and wires between the shields and the circuit board.

- () Refer to Detail 2-9C and mount a band switch shield to rotary switch SW403 as shown. Use a 4-40 \times 3/8" screw, a #4 lockwasher, and a 4-40 nut. Be sure the shield is on the correct side of the switch and is positioned as shown. Also be sure the tabs on the bottom of the shield enter their corresponding holes in the circuit board.

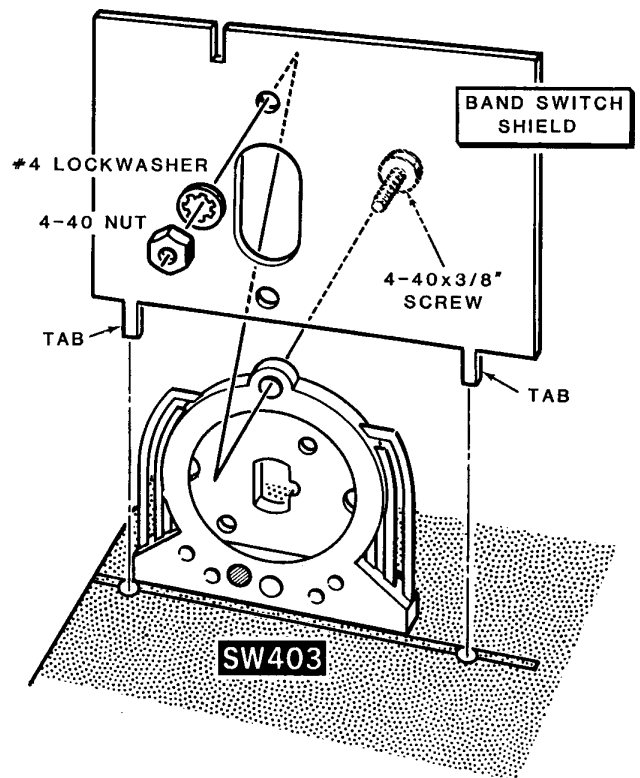

Detail 2-9C

Heathkit®

- () Refer to Detail 2-9D and similarly mount a band switch shield to rotary switch SW402 as shown. Be sure to mount the shield on the correct side of the switch as shown.
- () Refer to Detail 2-9E (Illustration Booklet, Page 17) and rotate the center portions of switches SW404, SW403, SW402, and SW401 so the notch is positioned as shown. Then slide the 7" shaft through the centers of these switches as shown.
- () Push the band switch shields down tight against the circuit board. Make sure the shields and switches are perpendicular to the circuit board. Then solder the two tabs on each shield to the foil.
- () Refer again to Detail 2-9E and use the following procedure to install the PA shield on the circuit board:
1. Position the PA shield as shown in the Pictorial (note the location of the small hole in the shield). Then make sure the tabs on the top of this shield enter the slots in the band switch shields. Also make sure the tab on the bottom of the shield enters its corresponding circuit board hole.
 2. Push the shield down tight against the circuit board and solder the bottom tab to the foil. NOTE: Be careful not to pinch any wires between the shield and the circuit board.
 3. Solder the top tabs on the PA shield to the notches in the band switch shields.

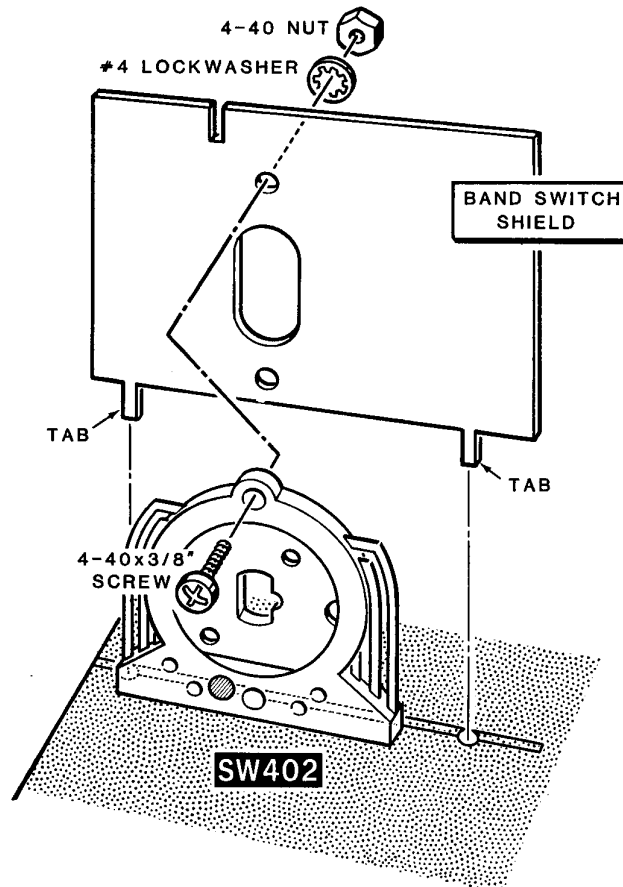

Detail 2-9D

CIRCUIT BOARD CHECKOUT

Carefully inspect the foil side of the circuit board for the following most-commonly-made errors:

- Unsoldered connections.
- Poor solder connections.
- Solder bridges between foil patterns.
- Protruding leads which could touch each other or the chassis when the circuit board is installed later.

Refer to the illustrations where parts are installed as you make the following visual checks:

- Transistors for the proper **type** and **installation**.
- Integrated circuits for the proper **type** and **installation**.
- Diodes for the proper **type** and **installation**.
- Electrolytic capacitors for the correct position of the positive (+) or negative (–) leads.

This completes the assembly of the T/R circuit board. Set the circuit board aside and proceed to "Chassis."

NOTE: If you have the HWA-9 Band Pack Accessory, check each of the parts supplied with that kit against the Parts List. Then install the parts on the oscillator and T/R circuit boards as directed in those Instructions (you will not have to perform the disassembly instructions). If you do not have the Accessory at this time, set the T/R circuit board aside and proceed directly to "Chassis."

CHASSIS

PARTS LIST

Unpack the remainder of the kit and check each part against the following list. The key numbers correspond to the numbers on the "Chassis Parts Pictorial" (Illustration Booklet, Pages 18 and 19). Return any part that is packed in an individual envelope, with the part number on it, back to the envelope after you identify it until that part is called for in a step. Do not throw away any packing material until all of the parts are accounted for.

To order a replacement part, always include the PART NUMBER. Use the Parts Order Form furnished with this kit. If a Parts Order Form is not available, refer to "Replacement Parts" inside the rear cover of this Manual. For prices, refer to the separate "Heath Parts Price List."

KEY HEATH No. Part No.	QTY.	DESCRIPTION	CIRCUIT Comp. No.
---------------------------	------	-------------	----------------------

ELECTRONIC COMPONENTS

NOTE: The following resistors are rated at 1/4-watt and have a tolerance of 5%. A 5% tolerance is indicated by a fourth color band of gold.

A1	6-470-12	1	47 Ω (yel-viol-blk) resistor	R4
A1	6-102-12	1	1000 Ω (brn-blk-red) resistor	R5
A2	10-1212	1	1000 (1 k) Ω control	R2
A2	10-1211	1	10 k Ω control	R1
A3	19-756	1	10 k Ω control with switch	R3/SW2
A4	21-761	2	.01 μ F (103) glass ceramic capacitor	C3, C4
A5	26-168	1	7-17 pF variable capacitor	C1
A6	60-26	1	Slide switch	SW3
A7	63-1410	1	Rotary switch	SW1
A8	407-765	1	Meter	M1

KEY HEATH No. Part No.	QTY.	DESCRIPTION	CIRCUIT Comp. No.
---------------------------	------	-------------	----------------------

HARDWARE

NOTE: Hardware packets are marked to show the size of the hardware they contain (HDW #2 & #3, or HDW #4, etc.). You may have to open more than one packet to locate all of the hardware of any one (#6, for example) size.

#2 & #3 Hardware

B1	250-467	2	2-56 \times 3/16" screw
B2	250-1172	1	2-56 \times 1/4" screw
B3	252-51	4	2-56 nut
B4	254-7	1	#3 lockwasher

#4 Hardware

C1	250-156	2	4-40 \times 1/8" setscrew
C2	250-1412	4	4-40 \times 3/8" screw
C3	250-1448	4	4-40 \times 3/8" flat head screw
C4	252-2	12	4-40 nut
C5	254-9	12	#4 lockwasher

KEY No.	HEATH Part No.	QTY.	DESCRIPTION	CIRCUIT Comp. No.
---------	----------------	------	-------------	-------------------

#6 Hardware

D1	250-208	3	6-32 × 1/8" screw	
D2	250-1282	9	6-32 × 1/8" setscrew	
D3	250-1307	14	#6 × 1/4" sheet metal screw	
D4	250-1325	9	6-32 × 1/4" screw	
D5	250-1432	4	#6 × 3/8" sheet metal screw	
D6	250-1425	13	6-32 × 1/2" screw	
D7	250-168	2	6-32 × 1-3/8" screw	
D8	252-3	47	6-32 nut	
D9	252-66	1	6-32 wingnut	
D10	253-21	2	#6 flat washer	
D11	254-1	44	#6 lockwasher	
D12	259-1	6	#6 solder lug	

Other Hardware

E1	250-15	1	8-32 × 1/8" setscrew	
E2	252-7	10	Control nut	
E3	253-10	5	Control flat washer	
E4	254-4	2	Thick control lockwasher	
E5	254-5	2	Thin control lockwasher	
E6	255-1	5	1/8" spacer	
E7	259-10	2	Control solder lug	

CONNECTORS

F1	432-72	2	Male connector pin	
F2	432-73	2	Female connector pin	
F3	432-120	2	PCB connector	
F4	432-196	1	2-pin socket shell	
F5	432-866	6	Spring connector (includes one extra)	
F6	432-907	1	2-pin plug shell	
F7	432-970	1	5-pin socket shell	

KEY No.	HEATH Part No.	QTY.	DESCRIPTION	CIRCUIT Comp. No.
---------	----------------	------	-------------	-------------------

Connectors (Cont'd)

F8	434-42	2	Phono socket	J3, J5
F9	436-4	1	Phone jack	J2
F10	436-5	1	Coaxial jack	J4

SHEET METAL PARTS

G1	90-566-3	2	Cabinet shell	
G2	200-1441	1	Main chassis	
G3	200-1442	1	Subchassis	
G4	203-2162-1	1	Rear panel	
G5	203-2163-1	1	Front panel	
G6	204-2692	1	Drive bracket	
G7	206-1481	1	BFO shield	
G8	206-1472	1	VFO shield	

MISCELLANEOUS

H1	75-61	4	Chassis nut	
H2	100-1839	1	Vernier drive assembly	
H3	260-16	1	Alligator clip	
H4	261-28	2	Thin foot	
H5	261-44	2	Thick foot	
H6	354-5	3	Cable tie	
H7	446-602-2	1	Dial window	
H8	455-15	1	Collar	
H9	456-50	1	VFO shaft	
H10	462-1130	4	Small knob	
H11	462-1137	1	Large knob	
H12	464-78-1	1	Tuning dial	
H13	490-5	1	Nut starter	
H14	490-109	1	Alignment tool (short)	
H15	490-218	1	Alignment tool (long)	

STEP-BY-STEP ASSEMBLY

Refer to Pictorial 3-1 (Illustration Booklet, Page 19) for the following steps.

() Refer to Detail 3-1A Part A and disassemble the vernier drive assembly as shown. Discard the two setscrews, control nut, and two 2-56 screws (if they were supplied with the drive assembly). Save the large shoulder coupler that is threaded onto the drive assembly.

() Refer again to Detail 3-1A Part A and start two $6-32 \times 1/8$ " ~~4-40~~ $\times 1/8$ " setscrews into the vernier drive assembly as shown.

() C1: Use the following procedure to mount the vernier drive assembly and the 7-17 pF variable capacitor to the drive bracket:

1. Refer to Detail 3-1A Part B and push the drive assembly onto the shaft of the variable capacitor. Do not tighten the setscrews yet. Then slide a **thin** control lockwasher onto the bushing of the drive assembly.
2. Set the capacitor/drive assembly into the drive bracket so the lockwasher is inside the chassis as shown in the Pictorial. Push the drive assembly down toward the bottom of the slot in the chassis. Then use a control nut to secure the drive assembly to the chassis. Only tighten this nut finger tight at this time.
3. Loosely mount the capacitor to the VFO chassis with three $6-32 \times 1/8$ " screws. Tighten these screws finger tight. Then tighten the two setscrews in the drive assembly.
4. Start a $6-32 \times 1/8$ " setscrew into the VFO shaft. Then push the shaft onto the shaft of the drive assembly and tighten the setscrew.
5. Rotate the shaft of the drive assembly to make sure it turns smoothly. Then alternately tighten (in small amounts) the three screws that secure the capacitor to the chassis. Keep checking the operation of the assembly to make sure it still operates smoothly until you have the three screws tight.
6. Tighten the vernier drive control nut.
7. Temporarily remove the VFO shaft and set it aside.
8. Reinstall the shoulder coupler onto the vernier drive assembly. Be sure the shoulder on the washer is away from the VFO chassis as shown in the Pictorial. Also be sure to tighten the coupler securely.
9. Set the VFO assembly aside temporarily.

PART A

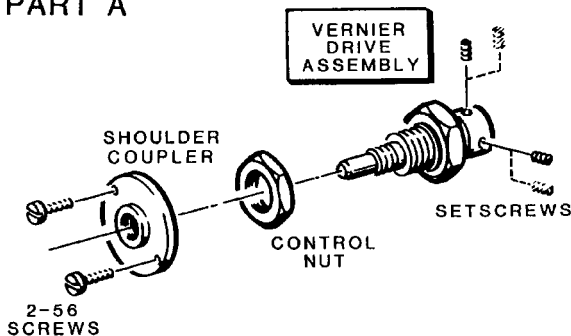

PART B

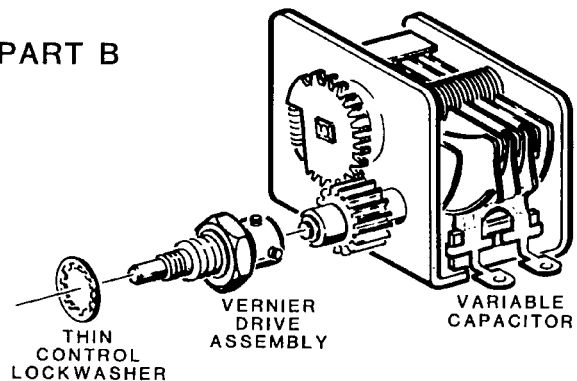

Detail 3-1A

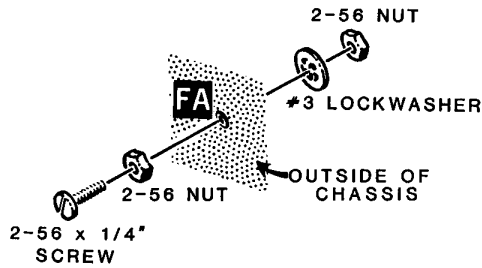

Detail 3-2A

- () Refer to Detail 3-2A and turn a 2-56 nut all the way onto a 2-56 × 1/4" screw. Then use a #3 lockwasher and another 2-56 nut to mount the screw onto the front of the main chassis at FA. NOTE: This screw will be used as a dial stop when the dial is installed.

NOTE: Use the nut starter to hold and start 4-40 and 6-32 nuts on screws.

- () Refer to Detail 3-2B and mount a 4-40 × 3/8" flat head screw onto the front of the main chassis at FB. Use a #4 lockwasher and a 4-40 nut. Only tighten the nut finger tight at this time.

Refer to Pictorial 3-2 (Illustration Booklet, Page 20) for the following steps.

- () Position the main chassis as shown in the Pictorial.
- () Refer to the inset drawing on the Pictorial and press chassis nuts into both of the square holes in either side of the main chassis.
- () Similarly, press chassis nuts into both of the square holes in the other side of the main chassis.

- () Similarly, mount 4-40 × 3/8" flat head screws on the front of the main chassis at FC, FD, and FE.

- () Refer to Detail 3-2B and position the VFO assembly (assembled earlier) onto the four screws at FB, FC, FD, and FE. Hold the assembly in place while you tighten the four screws. Then use four #4 lockwashers and four 4-40 nuts to secure the VFO assembly in place.

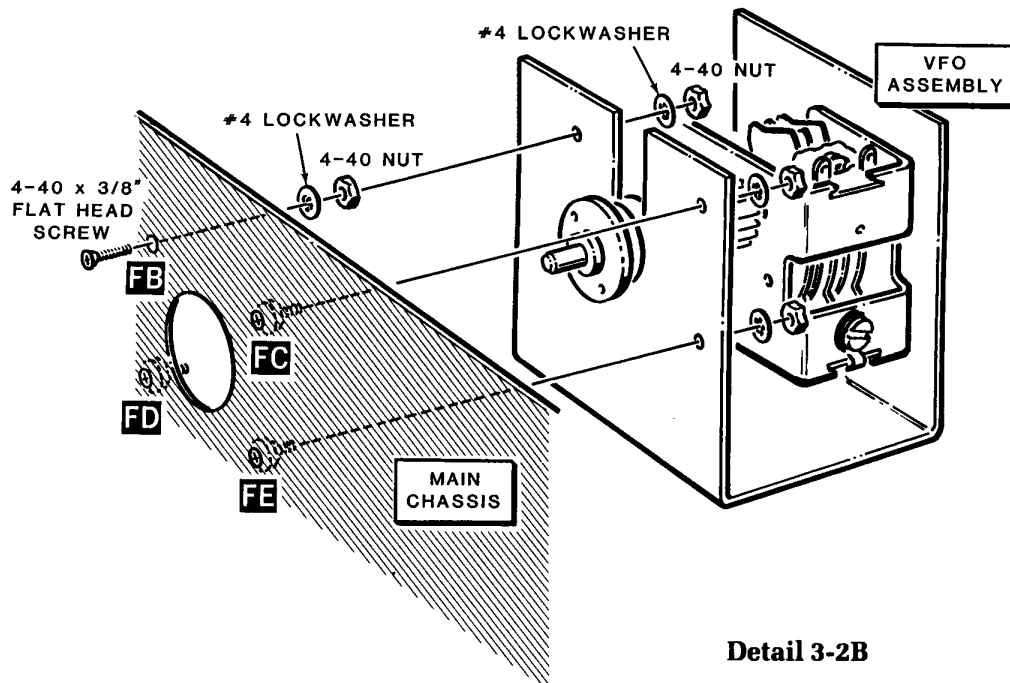

Detail 3-2B

Heathkit®

() Use the following procedure to mount the tuning dial onto the vernier drive assembly:

1. Turn a 2-56 nut all the way onto each of the two 2-56 \times 3/16" screws.
2. Use the prepared screws to mount the tuning dial to the shoulder coupler on the vernier drive assembly as shown. Be sure to position the tuning dial so the dial stop is inside the circular slot as shown. NOTE: The actual position of the lettering on the dial may vary from that shown.

() Push the VFO shaft (set aside earlier) all the way onto the shaft of the vernier drive assembly. Then tighten the setscrew.

() Refer to Detail 3-2C and use the following procedure to set the dial stop:

1. Loosen the two setscrews in the vernier drive bushing.
2. Use your fingers to rotate the smaller gear (brass) on the variable capacitor until the indicated end of the rotor is between the indicated holes in the frame of the capacitor.
3. Turn the VFO shaft until the right end of the tuning dial is against the dial stop as shown.
4. Tighten the two setscrews in the vernier drive bushing.

() Set the main chassis assembly aside temporarily.

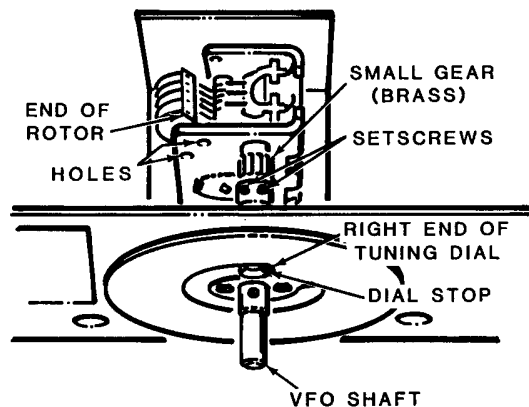

Detail 3-2C

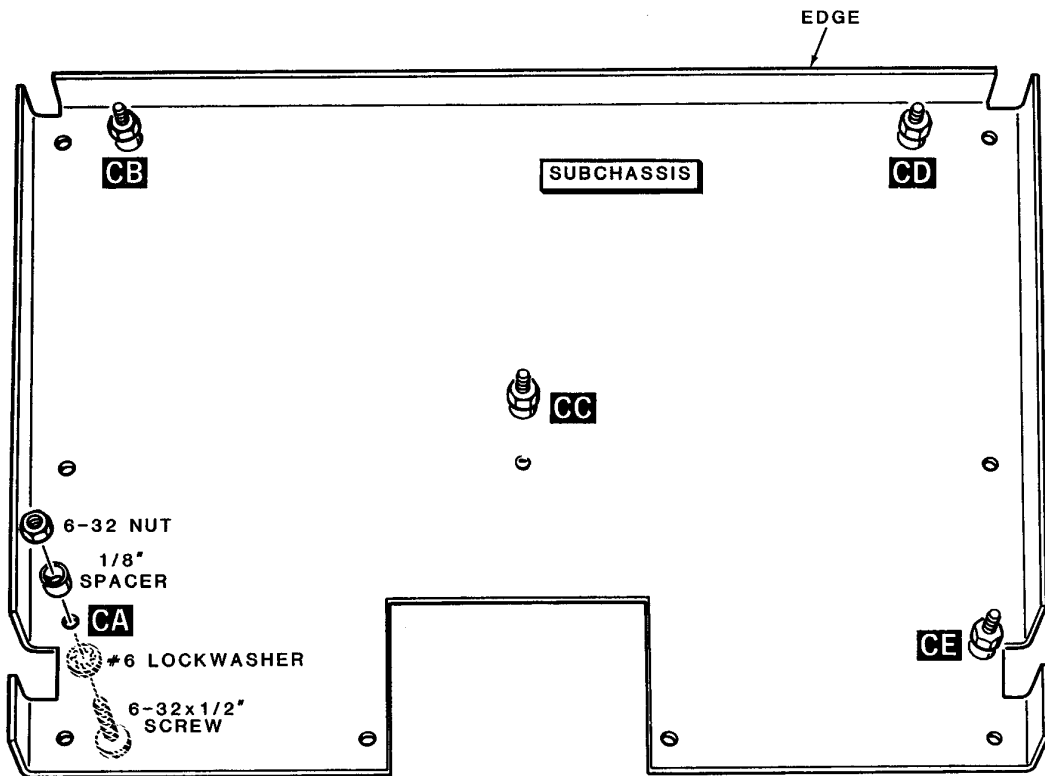

PICTORIAL 3-3

Heathkit®

Refer to Pictorial 3-3 for the following steps.

- () Position the subchassis as shown in the Pictorial (note that the edge on the subchassis faces upward).

NOTE: Only the screw size is called out in the following steps. When a step calls for "6-32 × 1/2" hardware," for example, it means you should use a 6-32 × 1/2" screw, one or more #6 lockwashers, and a 6-32 nut. The Pictorial or Detail referred to in the step shows the proper number and use of the lockwashers.

- () Use 6-32 × 1/2" hardware to mount a 1/8" spacer to the subchassis at CA as shown. Only tighten the hardware finger tight at this time.
- () Similarly, mount 1/8" spacers to the subchassis at CB, CC, CD, and CE. Tighten the hardware finger tight.
- () Refer to Detail 3-3A and temporarily position the T/R circuit board onto the subchassis hardware. Hold the circuit board in place while you tighten the hardware at CA, CB, CC, CD, and CE. Then remove the circuit board and set it aside. NOTE: If you could not tighten the hardware at one or more of the locations, tighten the corresponding nut after you remove the circuit board.

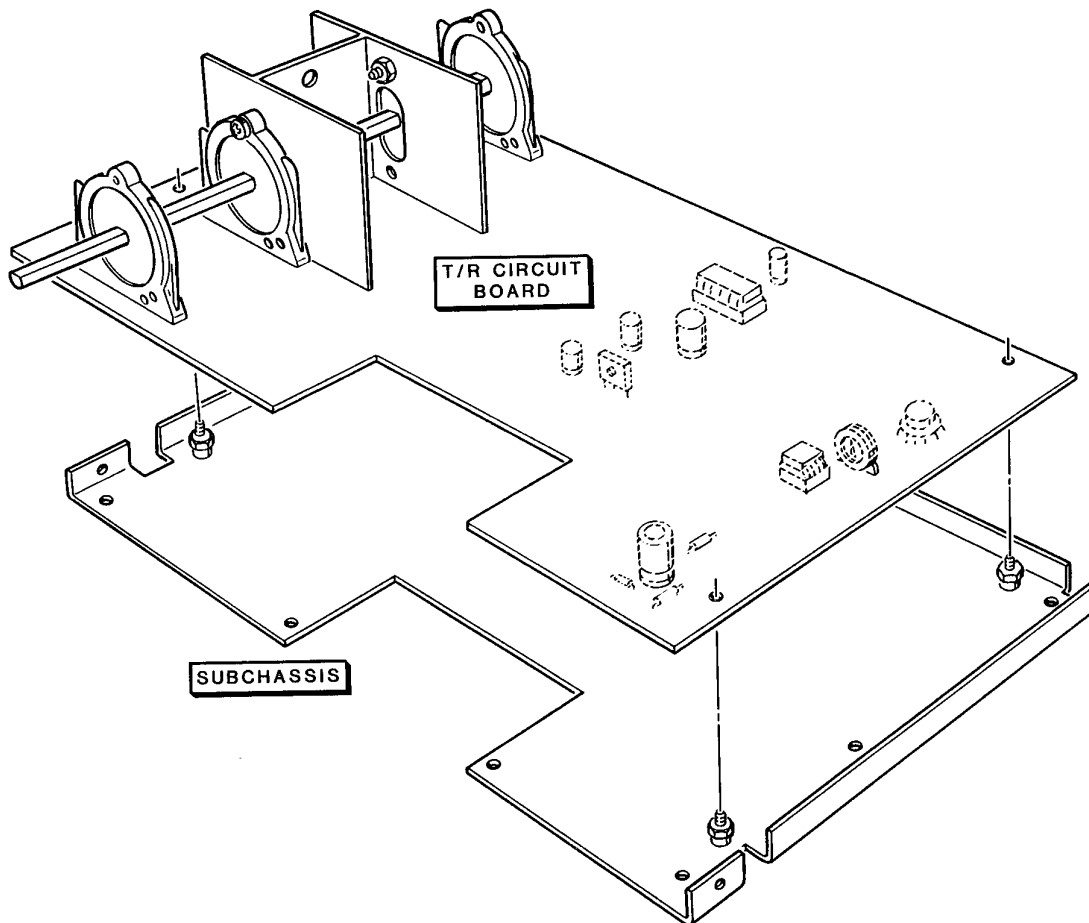

Detail 3-3A

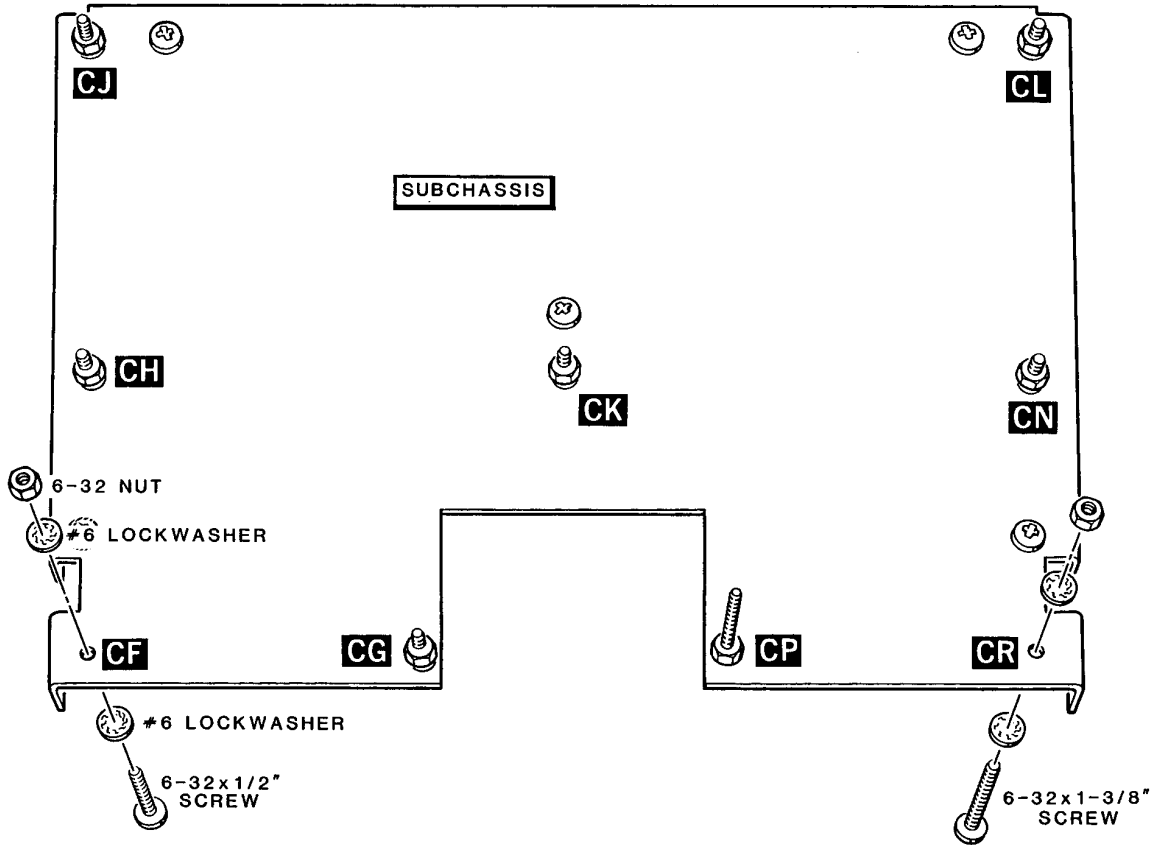

PICTORIAL 3-4

Heathkit®

Refer to Pictorial 3-4 for the following steps.

- () Reposition the subchassis as shown in the Pictorial (note that the edge on the chassis faces downward).
- () Mount 6-32 \times 1/2" hardware to the subchassis at CF, CG, CH, CJ, CK, CL, and CN. Tighten the hardware finger tight.

- () Similarly, mount 6-32 \times 1-3/8" hardware to the subchassis at CP and CR. Tighten the hardware finger tight.
- () Refer to Detail 3-4A and temporarily position the oscillator circuit board onto the subchassis hardware. Hold the circuit board in place while you tighten the hardware at CF, CG, CH, CJ, CK, CL, CN, CP, and CR. Then remove the circuit board and set it aside. NOTE: If you could not tighten the hardware at one or more of the locations, tighten the corresponding nut after you remove the circuit board.

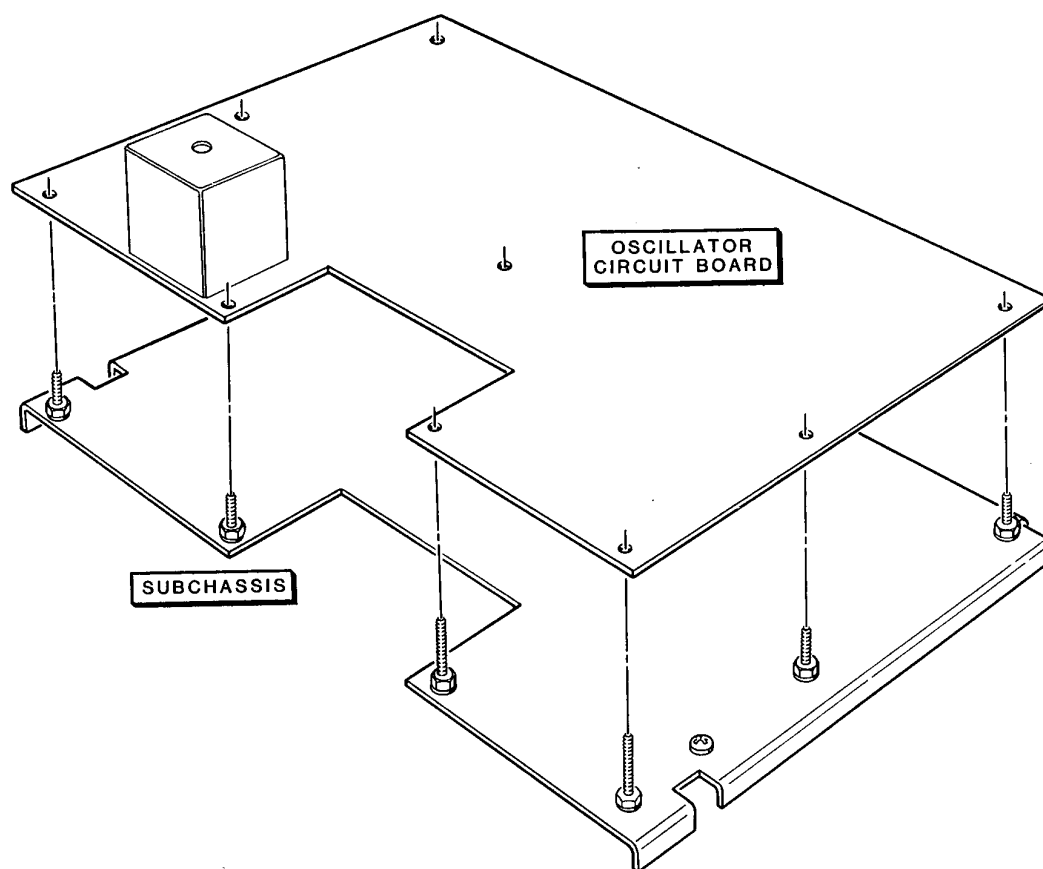

Detail 3-4A

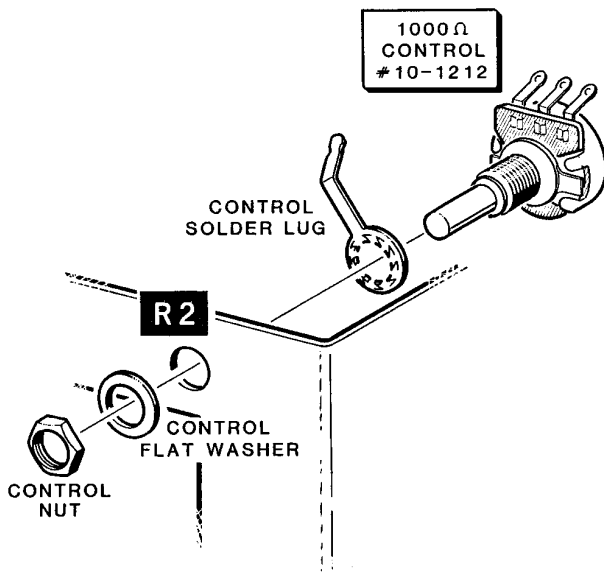

Detail 3-5A

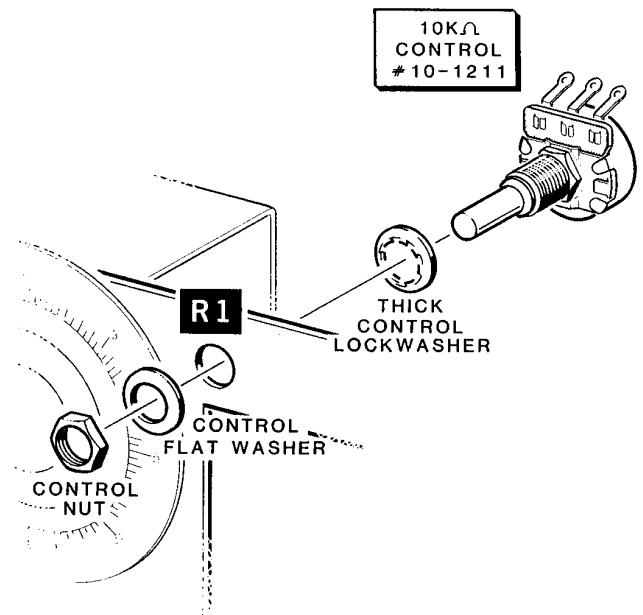

Detail 3-5B

Refer to Pictorial 3-5 (Illustration Booklet, Page 21) for the following steps.

() Use the following procedure to mount the subchassis to the main chassis:

1. Position the main chassis so the four larger round holes on the front are upward.
2. Position the subchassis into the main chassis so the edges are upward. Then use four 6-32 × 1/4" sheet metal screws to secure the subchassis to the main chassis at FF, FG, FH, and FJ.

() R2: Refer to Detail 3-5A and mount the 1000 (1 k) Ω control (#10-1212) to the chassis at R2 as shown. Use a control solder lug, a control flat washer, and a control nut. Be sure to position the solder lug and the control as shown before you tighten the hardware.

() R1: Refer to Detail 3-5B and mount the 10 kΩ control (#10-1211) to the chassis at R1 as shown. Use a **thick** control lockwasher, a control flat washer, and a control nut. Be sure to position the control as shown before you tighten the hardware.

() R3/SW2: Refer to Detail 3-5C and mount the 10 kΩ control with switch (#19-756) to the chassis at R3/SW2 as shown. Use a control solder lug, a control flat washer, and a control nut. Be sure to position the solder lug and the control as shown before you tighten the hardware.

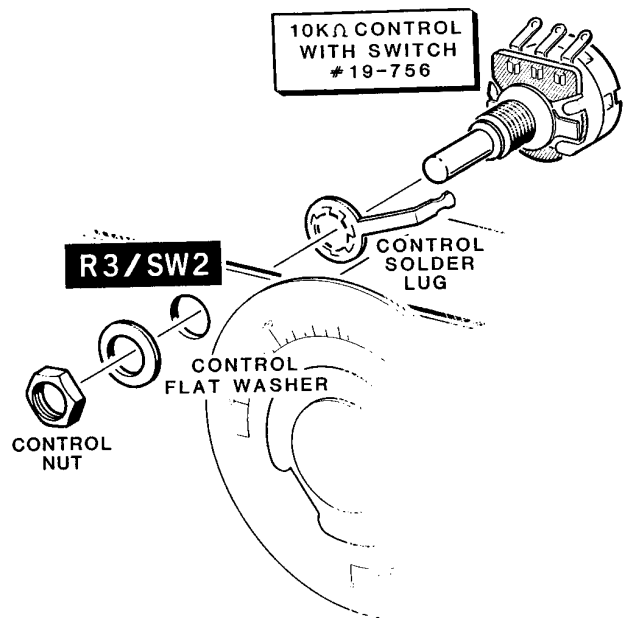

Detail 3-5C

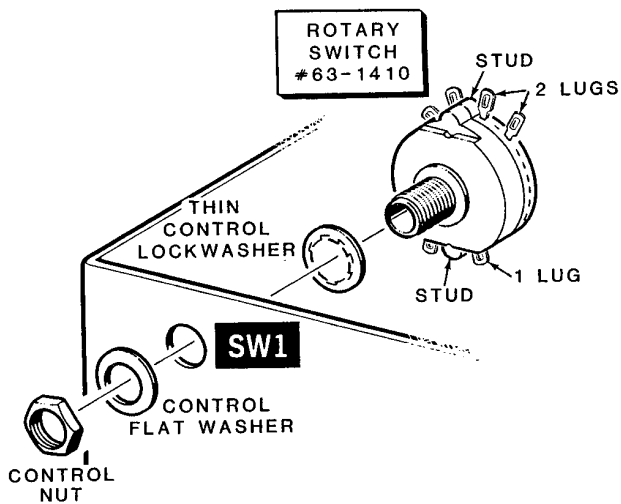

Detail 3-5D

() SW1: Refer to Detail 3-5D and mount the rotary switch (#63-1410) to the chassis at SW1 as shown. Use a **thin** control lockwasher, a control flat washer, and a control nut. Be sure to position the switch as shown before you tighten the hardware (note the positions of the lugs). Also make sure the switch studs are perpendicular to the subchassis.

() Set the chassis assembly aside temporarily.

Refer to Pictorial 3-6 (Illustration Booklet, Page 22) for the following steps.

() Position the T/R circuit board as shown in the Pictorial.

NOTES:

1. In the following steps you will be directed to prepare wires and cables and connect one end to the circuit board. The other ends of these wires and cables will be connected later.

2. When a step directs you to prepare a stranded wire, first cut the wire to the indicated length and remove 1/4" of insulation from each end.

Tightly twist together the wire strands at each end. Then melt a small amount of solder on these ends to hold the strands together.

() Prepare a 7" large red stranded wire. Then connect and solder one end of the wire to circuit board hole 12V/IN. Cut off any excess wire end.

() Prepare the following shielded cables. They are listed in the order in which you will use them. NOTE: To prepare these cables, use the same procedure that you used when you prepared shielded cables for the T/R circuit board.

3-1/2"	13"
14"	19-1/2"
14"	6"
16-1/2"	8"

Connect and solder one end of the shielded cables to the circuit board as follows:

() 3-1/2" cable: Inner lead to hole ANT, shield wires to nearby hole GND.

() 14" cable: Inner lead to hole NARROW/OUT, shield wires to nearby hole GND.

() 14" cable: Inner lead to hole WIDE/OUT, shield wires to nearby hole GND.

() 16-1/2" cable: Inner lead to hole BFO/IN, shield wires to nearby hole GND.

() 13" cable: Inner lead to hole TX/IN, shield wires to nearby hole GND.

() 19-1/2" cable: Inner lead to hole INJ/IN, shield wires to nearby hole GND.

() 6" cable: Inner lead to hole AUDIO/IN, shield wires to nearby hole GND.

() 8" cable: Inner lead to hole AUDIO/OUT, shield wires to nearby hole GND.



NOTE: In the following steps you will be directed to label some of the shielded cables coming from the T/R circuit board. You can use masking tape or something similar that you can easily write on. This will make it easier for you to identify these cables later. When you connect the free ends of these cables, you can remove the tape, if you desire.

- () Label the cable coming from Narrow/Out "NARROW/OUT."
- () Label the cable coming from Wide/Out "WIDE/OUT."
- () Label the cable coming from TX/In "TX/OUT."
- () Label the cable coming from INJ/In "INJ/OUT."
- () Label the cable coming from BFO/In "BFO/OUT."
- () Set the T/R circuit board aside temporarily.
- () Cut a 24" length of 8-wire cable Then refer to Detail 3-6A Part A (Illustration Booklet, Page 23) and use the following procedure to prepare one end of the cable:

1. Separate the brown and red wires (as a pair) from the rest of the wires for a length of 9". Then shorten these wires by 8". Now separate the brown and red wires from each other for a length of 1". Save the cut-off 2-wire cable for use later.
2. Separate the orange, yellow, green, and blue wires from the rest of the wires and each other for a length of 2".
3. Separate the violet and gray wires from the other wires and each other for a length of 7-1/4". Then shorten these wires by 6-1/2". Save the cut-off wires for use later.
4. Remove 1/4" of insulation from each wire at this end of the cable and prepare the ends.

NOTE: This end of the cable will be referred to as "end A."

- () Refer to Detail 3-6A Part B and use the following procedure to prepare the other end of the 8-wire cable:

1. Separate the brown, red, orange, yellow, and green wires (as a group) from the rest of the wires for a length of 11-1/2". Then shorten these wires by 3". Now separate the five wires from each other for a length of 1".
2. Separate the violet and gray wires (as a pair) from the blue wire for a length of 8". Then shorten this 2-wire pair by 5". Now separate the two wires from each other for a length of 1".
3. Remove 1/4" of insulation from the end of each wire at this end of the cable and prepare the ends.

NOTE: This end of the cable will be referred to as "end B."

Connect the wires at **end A** of the 8-wire cable to the T/R circuit board as follows. Solder each wire to the foil as you connect it and cut off any excess wire end.

- () Orange wire to hole +R.
- () Blue wire to hole KEY.
- () Green wire to either hole 9V **near the center of the circuit board.**
- () Yellow wire to hole YEL.

NOTE: The other wires at this end of the cable and the wires at end B will be connected later.

- () Locate the brown-red 2-wire cable you set aside earlier. Separate the wires at one end of this cable for 1" and separate the wires at the other end for 1-1/2". Then prepare the ends.

Connect the wires at the end of the 2-wire cable that has the wires separated for 1-1/2" to the T/R circuit board as follows. Solder each wire to the foil as you connect it and cut off any excess wire end.

- () Brown wire to METER -.

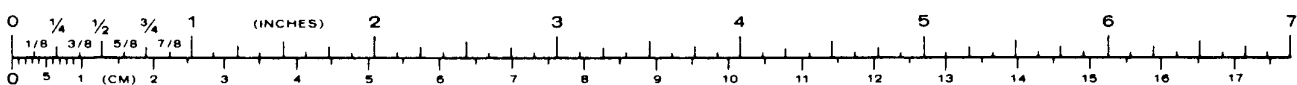

Heathkit®

- () Red wire to METER +.
- () Cut a 14" length of 8-wire cable. Set this cable aside for use later. Then separate the wires from the remaining length of 8-wire cable. Use these wires whenever a small stranded wire is called for.
- () Prepare the following **small** stranded wires:
 - 10" brown
 - 7" green
 - 9" orange
 - 7" red

Connect one end of the prepared wires to the T/R circuit board as follows. Solder each wire to the foil and cut off any excess wire end as you connect it. The free ends of these wires will be connected later.

- () Brown wire to hole + T.
- () Green wire to the remaining hole labeled 9V near the center of the circuit board.
- () Orange wire to hole 9V (toward the right edge of the circuit board).
- () Red wire to hole 12V.

Refer to Pictorial 3-7 (Illustration Booklet, Page 24) for the following steps.

- () Position the chassis as shown in the Pictorial.
- () Refer to Detail 3-7A (Illustration Booklet, Page 24) and use the following procedure to mount the T/R circuit board to the subchassis:
 1. Place a #6 lockwasher on each of the screws at CA, CB, CC, CD, and CE.
 2. Pull the 7" shaft all the way out of the rotary switches that are mounted on the T/R circuit board.
 3. Position the T/R circuit board onto the screws extending from the subchassis.

Be careful not to pinch any wires between the circuit board and the subchassis.

4. Use five 6-32 nuts to secure the circuit board to the screws.
5. Slide the 7" shaft back into the rotary switches. Make sure the flat on one side of the shaft is positioned as shown in the Pictorial.
6. Turn the 7" shaft three positions clockwise. Then pull the shaft back out of rotary switch SW404.
7. Start an 8-32 × 1/8" setscrew into the collar. Then slide the collar onto the end of the 7" shaft (between rotary switches SW403 and SW404).
8. Slide the shaft back into rotary switch SW404 as far as possible, position the collar against the back of rotary switch SW403, and tighten the setscrew (against the flat on the shaft).
9. Position transformer T401 so it is not touching the lugs of switch SW2.

NOTES:

1. In the following steps, (NS) means not to solder the connection because you will add other wires later. "S-" with a number, such as (S-2), means to solder the connection. The number following the "S-" tells you how many wires should be at the connection. This helps you check your work for errors as you go.
2. You may wish to turn the chassis over to make the connections in the next two steps.
 - () Connect the free end of the green wire, coming from hole 9V of the T/R circuit board, to switch SW1 lug 12 (NS).
 - () Connect the free end of the orange wire, coming from hole 9V of the T/R circuit board, to switch SW1 lug 12 (S-2).

- () Connect the free end of the large red wire, coming from hole 12V/IN of the T/R circuit board, to switch SW2 lug 2 (NS).
- () Bend the solder lugs at controls R3/SW2 and R2 away from the chassis enough to allow you to route wires between them and the chassis in the following steps.
- () Connect the free end of the red wire, coming from hole 12V of the T/R circuit board, to switch SW2 lug 2 (S-2).
- () Connect the free end of the brown wire, coming from hole +T of the T/R circuit board, to control R2 lug 3 (NS). Route this wire as shown in the Pictorial.
- () Connect a 1" bare wire between control R1 lugs 1 (S-2) and 2 (S-1).
- () Connect a 1" bare wire from control R2 lug 1 (NS) to the nearby solder lug (S-1).
- () Connect one end of the 8" large red wire to switch SW2 lug 1 (S-1). The other end of this wire will be connected later.
- () C3: Cut both leads of a .01 μ F (103) glass ceramic capacitor to 1/2". Then connect the capacitor between control R2 lugs 1 (NS) and 2 (S-2).
- () C4: Cut both leads of a .01 μ F (103) glass ceramic capacitor to 5/8". Then connect the capacitor between control R2 lugs 1 (NS) to 3 (NS).

Refer to Pictorial 3-8 (Illustration Booklet, Page 25) for the following steps.

- () Route the 8-wire cable coming from the T/R circuit board around the VFO assembly, along the front of the chassis, and down the corner to the other side of the chassis as shown in the Pictorial.

Connect some of the wires coming from the free end of the 8-wire cable as follows:

- () Violet wire to control R1 lug 1 (NS).
- () Gray wire to control R1 lug 3 (S-1).
- () Red wire to control R2 lug 2 (NS).
- () Brown wire to control R2 lug 3 (NS).
- () Prepare the following wires:

three 1" **small** bare

one 8" **large** red stranded

- () Connect a 1" bare wire from control R3 lug 3 (NS) to the nearby solder lug (S-1).

- () R5: Cut both leads of a 1000 Ω (brn-blk-red) resistor to 1/2". Then connect the resistor between control R2 lugs 1 (S-4) and 3 (S-4).
- () Route the brown-red 2-wire cable across the circuit board and out through the large rectangular hole in the front of the chassis as shown in the Pictorial. The free ends of these wires will be connected later.
- () Connect the free end of the shielded cable, coming from holes Audio/In and GND on the T/R circuit board, to control R3 as follows:

Inner lead to lug 2 (S-1).

Shield wires to lug 3 (NS).

- () Prepare an 8" shielded cable. Then connect the wires at one end of the cable to control R3 as follows:

Inner lead to lug 1 (S-1).

Shield wire to lug 3 (S-3).

- () Route the free end of the cable coming from control R3 as shown in the Pictorial; it will be connected later.

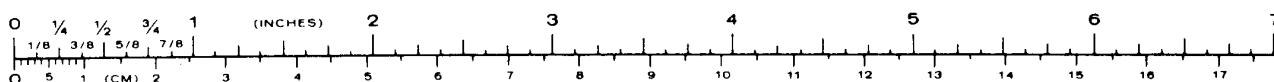

Heathkit®

Refer to Pictorial 3-9 (Illustration Booklet, Page 26) for the following steps.

- () Locate the 14" 8-wire cable that you set aside earlier. Then refer to Detail 3-9A (Illustration Booklet, Page 26) and use the following procedure to prepare one end of the cable:

1. Separate the wires for a length of 2-1/2".
2. Shorten each wire to the length shown.
3. Remove 1/4" of insulation from each wire at this end of the cable and prepare the ends.

NOTE: This end of the cable will be referred to as "end A."

- () Refer again to Detail 3-9A and use the following procedure to prepare the other end of the 14" cable:

1. Separate the wires for a length of 2-1/2".
2. Shorten each wire to the length shown.
3. Remove 1/4" of insulation from each wire at this end of the cable and prepare the ends.

NOTE: This end of the cable will be referred to as "end B."

Position the cable as shown in the Pictorial. Then refer to the inset drawing on the Pictorial and connect the wires at end A (the end with the short brown wire) to switch SW1 as follows. NOTE: Some of the following switch lugs are hard to get to. You may find it easier to turn the chassis over to make some connections.

- () Brown wire to lug 1 (S-1).
- () Red wire to lug 2 (S-1).
- () Orange wire to lug 3 (S-1).
- () Yellow wire to lug 4 (S-1).
- () Green wire to lug 5 (S-1).
- () Blue wire to lug 6 (S-1).
- () Violet wire to lug 7 (S-1).
- () Gray wire to lug 8 (S-1).

NOTE: End B of this cable will be connected later.

- () Route the free ends of the cables labeled "Narrow/Out" and "Wide/Out" as shown in the Pictorial so they are between switch SW1 and control R3/SW2.

- () Route the free ends of the cables labeled "TX/Out", "INJ/Out", and "BFO/Out" and the cable coming from control R3 as shown in the Pictorial so they are in the corner of the chassis next to switch SW1.

Set the chassis assembly aside temporarily.

Refer to Pictorial 3-10 (Illustration Booklet, Page 27) for the following steps.

- () Position the rear panel as shown in the Pictorial.
- () Use the following procedure to mount a ground post onto the rear panel:
 1. Scrape or sand any excess paint from around hole RA on the inside of the panel.
 2. Use 6-32 × 1/2" hardware to mount a #6 solder lug to the panel at RA. Position the solder lug as shown in the Pictorial. Then tighten the hardware securely.
 3. Slide two #6 flat washers onto the end of the 6-32 × 1/2" screw. Then use a 6-32 wingnut to secure these washers. Only tighten this nut finger tight.

NOTE: Scrape or sand any excess paint from around the mounting holes on the inside of the rear panel when you mount the jacks and socket in the next three steps. This will insure a good ground.

- () J4: Refer to Detail 3-10A and mount the coaxial jack onto the **outside** of the rear panel at J4. Use 4-40 × 3/8" hardware.

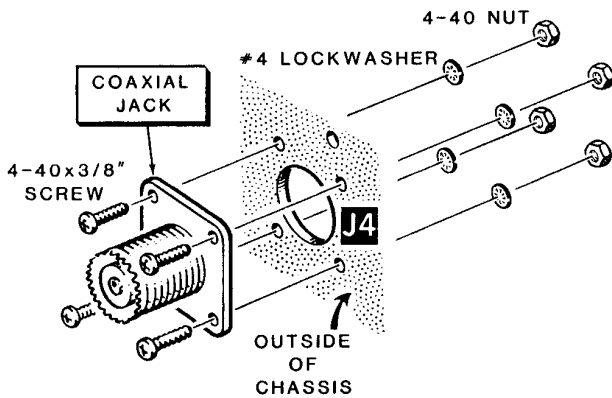

Detail 3-10A

- () J3: Mount a phono socket onto the inside of the rear panel at J3. Use 6-32 × 1/4" hardware. Be sure to position the socket as shown.
- () J2: Mount the phone jack onto the inside of the rear panel at J2. Use a **thick** control lock-washer, a control flat washer, and a control nut. Be sure to position the jack as shown before you tighten the hardware.
- () S1: Refer to Detail 3-10B and bend back the tabs on the 2-pin socket shell as shown. Then push the socket shell into rear panel hole S1 until it locks into place. Be sure the pointed side of the socket shell is toward the right as shown.

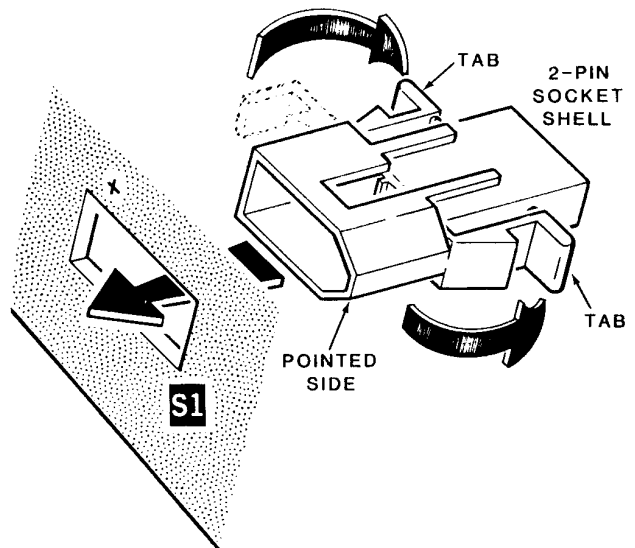

Detail 3-10B

Refer to Pictorial 3-11 (Illustration Booklet, Page 28) for the following steps.

- () Position the rear panel near the chassis assembly as shown. Then use six #6 × 1/4" sheet metal screws to secure the panel to the chassis. Start all six screws before you tighten them. Be careful not to pinch any wires or cables between the panel and the chassis.

Connect the free end of the shielded cable coming from T/R circuit board holes ANT and GND as follows:

- () Inner lead to coaxial jack J4 lug 1 (S-1).
- () Shield wires to solder lug RA (S-1).
- () Refer to Detail 3-11A and install a male connector pin on the free end of the large red wire coming from switch SW2. Then push this connector pin into socket S1 hole 1 until it locks in place.
- () Prepare a 4" large black stranded wire.
- () Install a male connector pin on one end of the prepared wire. Then push this connector pin into socket S1 hole 2 until it locks into place. Connect the free end of this wire to socket J3 lug 2 (NS).
- () R4: Cut both leads of a 47 Ω (yel-viol-blk) resistor to 5/8". Then connect the resistor between jack J2 lugs 1 (NS) and 3 (NS). Position the resistor as shown in the Pictorial. Be sure the leads of this resistor do not touch anything other than the lugs to which they are connected.
- () Prepare a 4" shielded cable. Then connect one end of the cable to socket J3 as follows:

Inner lead to lug 1 (S-1).

Shield wires to lug 2 (S-2).

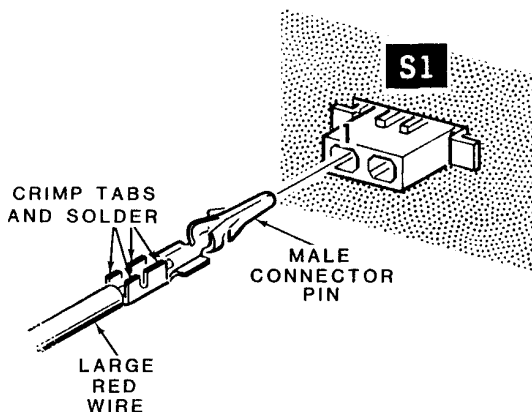

Detail 3-11A

- () Connect the free end of the 4" shielded cable to jack J2 as follows:
 - Inner lead to lug 2 (S-1).
 - Shield wires to lug 1 (NS).
- () Connect the free end of the shielded cable, coming from T/R circuit board holes Audio/Out and GND to jack J2 as follows:
 - Inner lead to lug 3 (S-2).
 - Shield wires to lug 1 (S-3).
- () Position the wires and cables that are connected to the T/R circuit board and the rear panel as neatly as possible. Then refer to the inset drawing on the Pictorial and install cable ties on some of these wires and cables in the areas shown.
- () Check the shield wires on jack J2. Make sure these wires only touch lug 1.

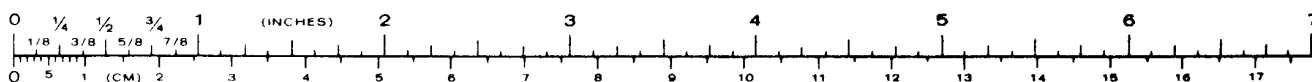

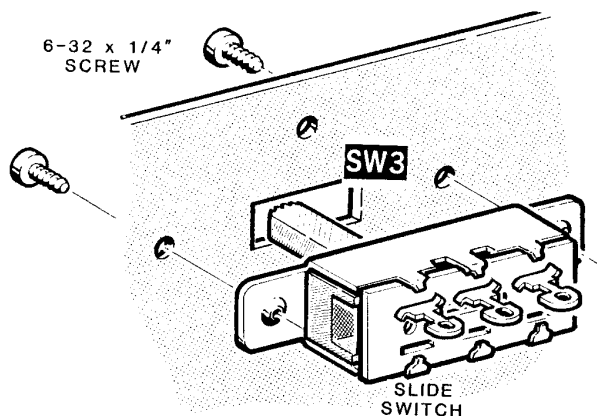

Detail 3-12A

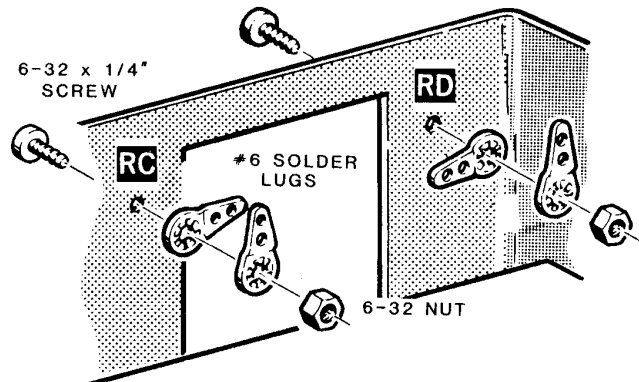

Detail 3-12C

Refer to Pictorial 3-12 (Illustration Booklet, Page 29) for the following steps.

- () Turn the chassis assembly over (T/R circuit board down) and position it as shown in the Pictorial.
- () SW3: Refer to Detail 3-12A and mount the slide switch to the front of the chassis at SW3. Use two 6-32 × 1/4" screws. Be sure to position the switch so the lugs are closest to the top edge of the chassis.
- () Refer to Detail 3-12B and mount a #6 solder lug to the chassis at RB. Use a 6-32 × 1/4" screw and a 6-32 nut. Be sure to position the solder lug as shown in the Pictorial before you tighten the hardware.

- () Refer to the inset drawing on the Pictorial and flatten four #6 solder lugs. Use these solder lugs in the next two steps.
- () Refer to Detail 3-12C and mount two #6 solder lugs to the front of the chassis at RC. Use a 6-32 × 1/4" screw and a 6-32 nut. Be sure to position each solder lug as shown in the Pictorial before you tighten the hardware.
- () Similarly, mount two #6 solder lugs to the front of the chassis at RD. Be sure to position the solder lugs as shown in the Pictorial before you tighten the hardware.
- () Route the cable labeled "INJ/Out" across the front of the chassis so it is between switch SW3 and solder lug RB. The free end of this cable will be connected later.

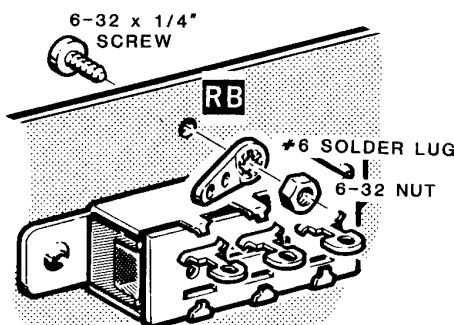

Detail 3-12B

NOTE: When you connect the cables to switch SW3 and solder lug RB, in the following steps, be careful not to burn the insulation on any nearby cables.

Connect some of the cables coming from the right front corner of the chassis as follows:

- () Cable labeled "Narrow/Out": Inner lead to switch SW3 lug 3 (S-1); shield wires to solder lug RB (NS).
- () Unlabeled cable: Inner lead to switch SW3 lug 2 (S-1); shield wires to solder lug RB (NS).

Heathkit[®]

- () Cable labeled "Wide/Out": Inner lead to switch SW3 lug 1 (S-1); shield wires to solder lug RB (S-3).
- () Prepare a 2-1/2" shielded cable. NOTE: Cut off the shield wires at **one end** of this cable.
- () Refer to Detail 3-12D and connect the inner lead at the end of the prepared shielded cable that does not have a shield to variable capacitor C1 lug 1 (S-1). The free end of this cable will be connected later.

- () Refer again to Detail 3-12D and use the following procedure to mount the VFO shield onto the VFO chassis:

1. Refer to Part A of the Detail and slide the VFO shield onto the VFO chassis. Make sure all the edges of the shield are on the outside of the VFO chassis. Also make sure the shielded cable coming from the variable capacitor extends through the indicated slot in the VFO shield.
2. Turn the chassis assembly over so the T/R circuit board is up. Then refer to Part B of the Detail, bend over the two tabs on the VFO shield, and solder them to the VFO chassis.

PART A

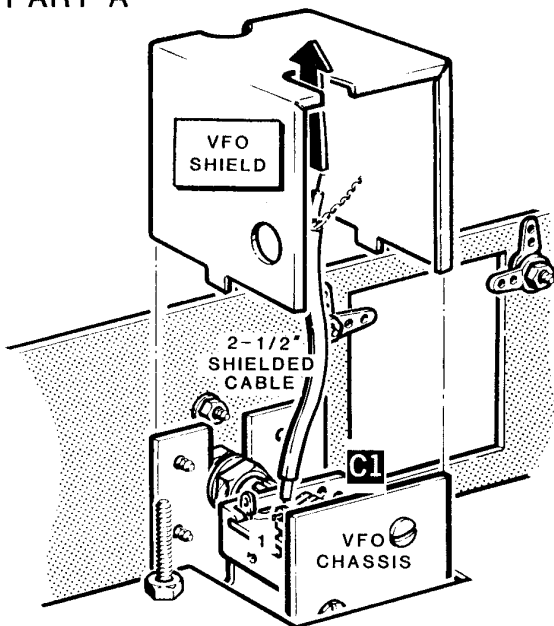

PART B

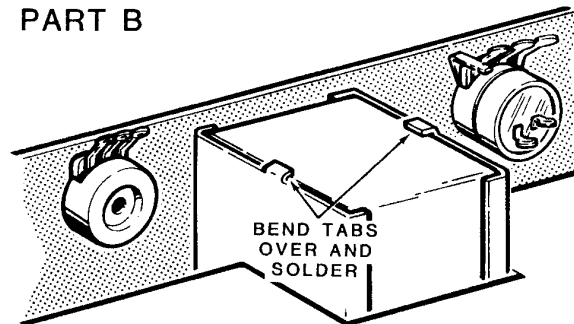

Detail 3-12D

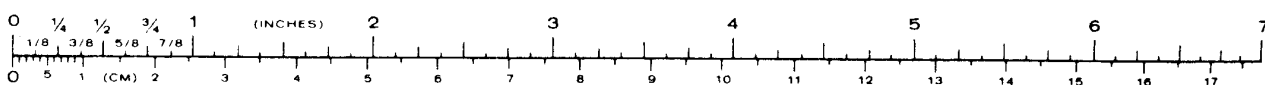

Refer to Pictorial 3-13 (Illustration Booklet, Page 30) for the following steps.

- () Position the chassis assembly as shown in the Pictorial so the T/R circuit board is down, if this has not already been done.
- () Position the oscillator circuit board near the chassis. Then connect the violet wire of the 8-wire cable coming from the front left corner of the chassis to oscillator circuit board hole D (S-1).
- () Connect the gray wire of the 8-wire cable coming from the left front corner of the chassis to oscillator circuit board hole C (S-1).
- () Refer to Detail 3-13A Part A and install a spring connector on the free end of the brown, red, orange, yellow, and green wire of the 8-wire cable coming from the left front corner of the chassis.

Position the 5-pin socket shell as shown in Detail 3-13A Part B. Then push the spring connectors on the wires into the holes of the socket shell as follows. Be sure to push on each wire until it locks into place.

- () Yellow wire into hole 1.
- () Orange wire into hole 2.
- () Brown wire into hole 3.
- () Green wire into hole 4.
- () Red wire into hole 5.
- () Push the 5-pin socket onto oscillator circuit board plug P101. Be sure the yellow wire is at 12V as shown in the Pictorial.
- () Connect the free end of the shielded cable labeled "INJ/Out" to the oscillator circuit board as follows:

Inner lead to hole INJ/OUT (S-1).

Shield wires to nearby hole GND (S-1).

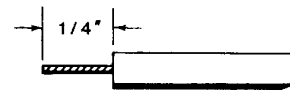

PART A

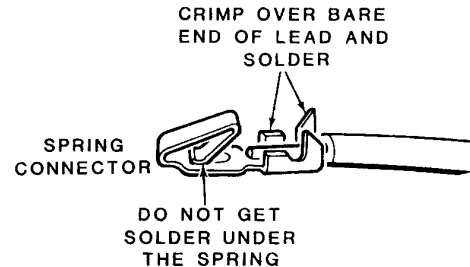

PART B

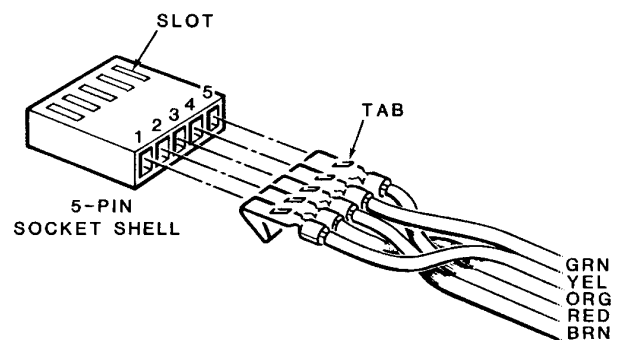

Detail 3-13A

- () Connect the free end of the shielded cable labeled "TX/Out" to the oscillator circuit board as follows:
 - Inner lead to hole TX/OUT (S-1).
 - Shield wires to nearby hole GND (S-1).
- () Connect the free end of the shielded cable labeled "BFO/Out" to the oscillator circuit board as follows:
 - Inner lead to hole BFO/OUT (S-1).
 - Shield wires to nearby hole GND (S-1).

Heathkit[®]

Connect the wires at the free end of the 8-wire cable coming from the right front corner of the chassis to the oscillator circuit board as follows:

- () Gray wire to hole 10 (S-1).
- () Violet wire to hole 12 (S-1).
- () Blue wire to hole 15 (S-1).
- () Green wire to hole 17 (S-1).
- () Yellow wire to hole 20 (S-1).
- () Orange wire to hole 30 (S-1).
- () Red wire to hole 40 (S-1).
- () Brown wire to hole 80 (S-1).

Refer to Pictorial 3-14 (Illustration Booklet, Page 31) for the following steps.

- () Refer to Detail 3-14A (Illustration Booklet, Page 31) and turn an additional 6-32 nut onto each of the nine screws extending from the subchassis (at CF, CG, CH, CJ, CK, CL, CN, CP, and CR). Then place a #6 lockwasher onto each of these screws.

- () Position the oscillator circuit board into the chassis so the nine screws extending from the subchassis pass through the nine corresponding holes in the circuit board. Then use nine 6-32 nuts to secure the circuit board in place.
- () Refer to Detail 3-14B and use the following procedure to mount the BFO shield onto the oscillator circuit board:
 1. Position the shield as shown in Part A of the Detail. Then melt a bead of solder along the each of the four corner seams in the shield.
 2. Slide the BFO shield onto the two long screws at CP and CR as shown in Part B of the Detail. Then use two #6 lockwashers and two 6-32 nuts to secure the shield. Tighten the nuts only until they are snug.
- () Connect the free end of the shielded cable coming from variable capacitor C1 as follows:

Inner lead to PCB pin E (S-1).

Shield wires to nearby wire socket GND (S-1).

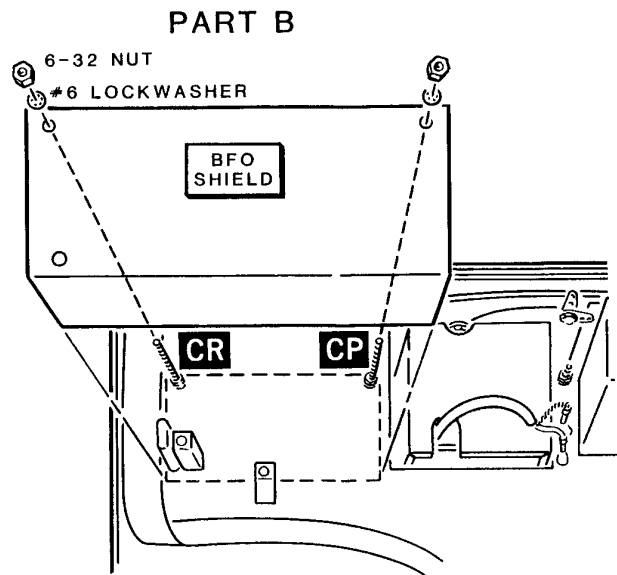
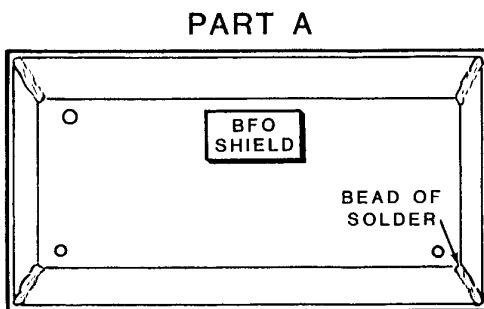

Detail 3-14B

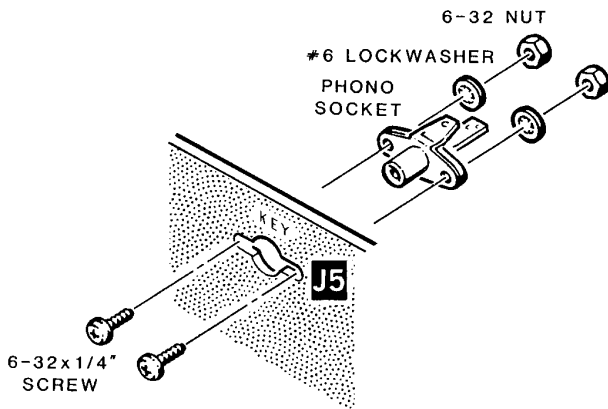

Detail 3-14C

NOTE: Scrape or sand any excess paint from around the mounting holes on the inside of the rear panel when you mount the socket in the next step.

- () J5: Refer to Detail 3-14C and mount a phono socket onto the rear panel at J5 as shown. Use 6-32 × 1/4" hardware. Be sure to position the socket as shown in the Pictorial.
- () Connect the free end of the blue wire coming from the 8-wire cable (near the left side of the chassis) to phono socket J5 lug 1 (S-1).
- () Route the wires and cables that are connected to the oscillator circuit board and the rear panel as shown. Then position the 8-wire cable and the shielded cable that run along the front of the chassis behind the indicated solder lugs at RC and RD. **NOTE:** Bend these solder lugs as necessary so they hold the cables in place.

Refer to Pictorial 3-15 (Illustration Booklet, Page 32) for the following steps.

- () Refer to Detail 3-15A and use the following procedure to install the dial window on the inside of the front panel:
 1. Position the front panel as shown so the side with the printing is down.

2. Draw a pencil line across the center of the front panel.
3. Carefully peel the backing paper strips from the dial window. Then position the window so the line on it lines up with the pencil line on the front panel. Also be sure the edge of the window is flush with the edge of the front panel. Then press the window into place.

- () Carefully inspect the lugs of the meter for a fine shorting wire that may be wrapped around the lugs. Remove any wire that you find.

M1: Position the meter near the front of the chassis. Then connect the 2-wire cable that extends through the large rectangular hole in the front of the chassis to the meter lugs as follows:

- () Brown wire to the negative (−) or unmarked lug (S-1).
- () Red wire to the positive (+) or dot marked lug (S-1).
- () Use the following procedure to mount the front panel onto the chassis:

1. Position meter M1 in the rectangular cut-out in the front panel as shown.
2. Hold the meter in place while you slide the front panel onto the four shafts at R2, R1, R3/SW2, and SW1. Make sure the knob on the slide switch passes through its hole in the front panel. Also make sure the meter lugs clear the T/R circuit board and the subchassis.
3. Use four control nuts to secure the front panel at R2, R1, R3/SW2, and SW1. Tighten these nuts only until they are snug.

Heathkit®

- () Start a 6-32 × 1/8" setscrew into each of the four small knobs and two setscrews into the large knob.
- () Turn the shaft of the CW LEVEL control fully counterclockwise. Then install a small knob on the shaft of this control. Be sure the knob pointer lines up with the line on the front panel at the 7-o'clock position before you tighten the setscrew.
- () Turn the shaft of the RIT control to the center of its rotation (detent position). Then install a small knob on the shaft of this control. Be sure the knob pointer lines up with the "0" on the front panel before you tighten the setscrew.
- () Turn the shaft of the AF GAIN control fully counterclockwise until it clicks, if this has not already been done. Then install a small knob
- on the shaft of this control. Be sure the knob pointer lines up with the line at "OFF" on the front panel before you tighten the setscrew.
- () Turn the shaft of the BAND switch fully counterclockwise. Then install a small knob on the shaft of this switch. Be sure the knob pointer lines up with "80" on the front panel before you tighten the setscrew.
- () Install a large knob on the main tuning shaft and tighten both setscrews.
- () Shake out any loose clippings or solder splashes that may be lodged in the wiring. Also carefully check the chassis connections to make sure they are all soldered properly.
- () Set the chassis aside temporarily.

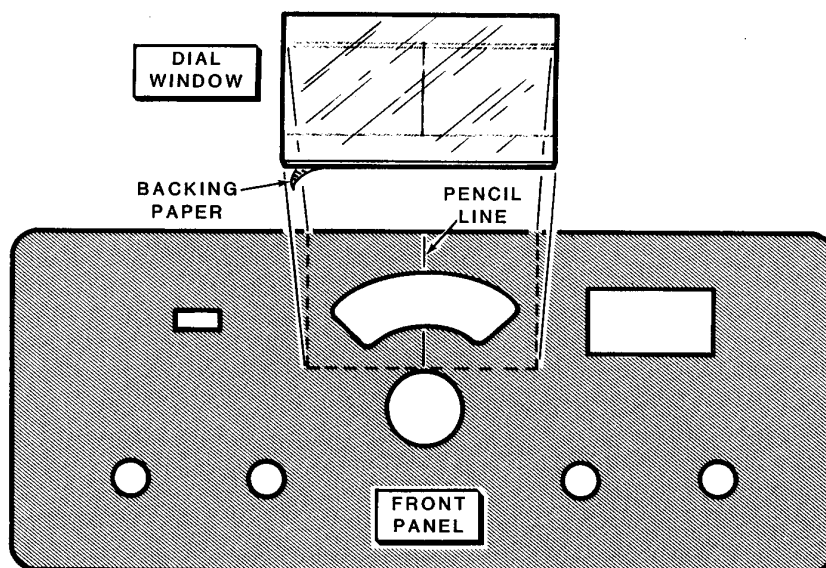

Detail 3-15A

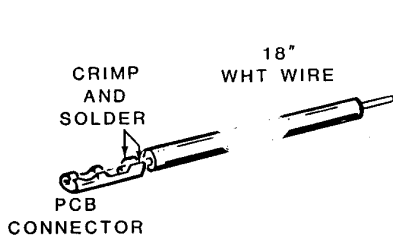

PICTORIAL 3-16

Refer to Pictorial 3-16 for the following steps.

- () Prepare an 18" white solid wire.
- () Solder a PCB connector onto one end of the prepared wire as shown in the Pictorial.

NOTE: This wire will be referred to as the "test lead" during the "Initial Tests."

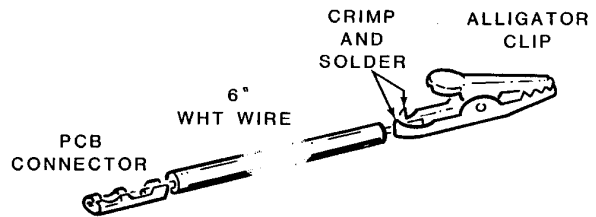

PICTORIAL 3-17

Refer to Pictorial 3-17 for the following steps.

- () Prepare a 6" white solid wire.
- () Solder a PCB connector on one end of the prepared wire.
- () Solder an alligator clip onto the other end of the prepared wire as shown in the Pictorial.

NOTE: This wire will be referred to as the "meter test lead" during the "Initial Tests."

Before you can perform the "Alignment," you may have to install a connector on the ends of your power supply leads, if this has not already been done. Refer ahead to "DC Power" in the "Installation and Operation" section of this Manual (Page 87) and install a connector (supplied) on your power supply leads. Then proceed to "Initial Tests."

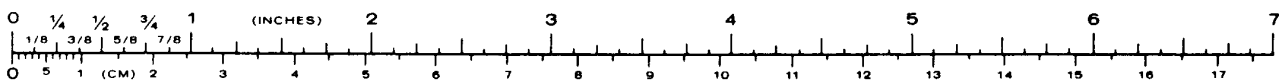

INITIAL TESTS

The following resistance tests will help assure you that there are no wiring errors or other problems that might prevent your unit from operating properly, or even damage components. You will need an ohmmeter to make these tests.

If you do not achieve the indicated results as you perform a test, locate and correct the problem before you proceed to the next test. A possible cause is listed for each test. Refer to the "In Case of Difficulty" section for help in locating more difficult problems.

RESISTANCE TESTS

The following resistance tests will help determine if there are any wiring errors, solder bridges, or other problems in your Transceiver. Perform all of the tests before you connect your Transceiver to a power source.

Set the front panel controls and switches as follows:

- CW LEVEL – fully counterclockwise.
- RIT – center of rotation (detent position).
- AF GAIN – fully counterclockwise (off).

- BAND switch – 80.
- SELECTIVITY – WIDE.
- Set your ohmmeter to the $R \times 100$ range and connect its common lead to the Transceiver chassis.

NOTE: If you do not obtain the correct meter readings in the next step, interchange the meter leads and recheck the readings.

- Touch the ohmmeter test probe to the points indicated in the following chart and observe the reading. Then change the BAND switch position and move the test probe to the next test point, etc.

Refer to Pictorial 4-1 (Illustration Booklet, Page 33) for the location of the following test points.

NOTE: With the BAND switch in any position other than the one indicated in the step, the resistance should measure approximately 1000 Ω higher than shown. If you do not have the accessory bands (30-, 17-, 12-, or 10-meters) installed, omit the tests marked with an asterisk.

<u>BAND</u>	<u>TEST POINT</u>	<u>OHMMETER READING</u>	<u>POSSIBLE CAUSE</u>
() 80	R107	350 to 700	A. 9-volt line (U402).
() 40	R109	350 to 700	B. Bandswitch wiring.
() 30*	R111	350 to 700	C. Short in corresponding mixer filter (L101 – L117)
() 20	R113	350 to 700	D. P101 wiring.
() 17*	R115	350 to 700	
() 15	R117	350 to 700	
() 12*	R119	350 to 700	
() 10*	R121	350 to 700	
()	Return the BAND switch to 80 before you make the following tests.		

<u>TEST POINT</u>	<u>OHMMETER READING</u>	<u>POSSIBLE CAUSE</u>
() Point E (wire socket).	300 to 700	A. 9-volt line. B. Main tuning capacitor C1. C. P101 wiring.
() Unplug P101.		
() Point E (wire socket).	300 to 700	A. VFO circuit, L118, Q102—Q106.
() 12 V pin (plug P101).	300 to 600	A. 12-volt line. B. BFO circuit, Q102. C. Mixer output, Q101. D. HFO output, Q111.

<u>TEST POINT</u>	<u>OHMMETER READING</u>	<u>POSSIBLE CAUSE</u>
() Set your ohmmeter to R × 1000.		
() R12 pin.	15 kΩ to 30 kΩ	A. Q103 circuit.
() Set your ohmmeter to R × 100.		
() T12 pin.	800 to 1800	A. T12 foil shorted. B. BFO circuit, D141, Q114, Q115.
() CWL.	3000 to 6000	A. D143 reversed or faulty.
() Reconnect plug P101.		
() 12 V pin.	300 to 600	A. Short on 12 V line, T/R board.
() R12 pin.	300 to 700	A. Short on R12 line. B. P101 wired wrong.
() T12 pin.	300 to 700	A. T12 line. B. CW LEVEL control wiring.
() 9 V pin.	300 to 800	A. T/R board. B. U301, T302.
() CWL.	300 to 700**	A. CW LEVEL control wiring. B. T12 line from C/R board.
() TP104.	infinite	A. Shorted cable at OSC or BFO/IN.
() Turn the Transceiver over as shown in Pictorial 4-2 (Illustration Booklet, Page 33) and set your ohmmeter to the R × 1000 range. Then make the following tests.		

** This indication should decrease as you turn the CW LEVEL control clockwise.

<u>TEST POINT</u>	<u>OHMMETER READING</u>	<u>POSSIBLE CAUSE</u>
() AF GAIN (lug 2).	0 to 10 k Ω as you rotate the control clockwise.	A. Shorted cable. B. Wiring of AF GAIN control or SELECTIVITY switch.
() Sidetone In cable (inner lead).	Infinite	A. Shorted cable.
() Be sure the SELECTIVITY switch is in the WIDE position.		
() Wide out cable (inner lead).	8 k Ω to 15 k Ω	A. Shorted cable. B. Selectivity switch wiring.
() Set the SELECTIVITY switch to NARROW.		
() Narrow out cable (inner lead).	8 k Ω to 15 k Ω	A. Switch wiring or cable.
() Set your ohmmeter to R \times 100.		
() Case of Q424.	300 to 500	A. Soldering, or Q424.
() Tx/In cable (inner lead).	300 to 500	A. Cable shorted or open. B. Oscillator board L137 shorted or open.

This completes the Initial Tests. Proceed to the "Alignment" section.

ALIGNMENT

An RF detector circuit is built into the Transceiver to aid you in the alignment procedure. The only equipment you will need is a VTVM or DVM with a 1 to 2 volts scale and a 15 volt scale, and a frequency counter with a range to 10 MHz and an accuracy of .01%.

INITIAL CONTROL SETTINGS

Refer to Pictorial 5-1 (Illustration Booklet, Page 34) and set the front panel controls and switches as follows:

- () CW LEVEL – fully counterclockwise.
- () RIT – center (detent) position.
- () AF GAIN – fully counterclockwise (OFF).
- () BAND switch – 80.
- () TUNING DIAL – 250 KHz.

Refer to Pictorial 5-2 (Illustration Booklet, Page 34) and set the T/R circuit board controls as follows (as viewed from the front of the Transceiver):

- () METER ZERO (R333) – 12 o'clock position.
- () MUTE DELAY (R445) – 3 o'clock position.
- () SIDETONE LEVEL (R368) – 3 o'clock position.
- () AGC SET (R329) – 3 o'clock position.

Refer to Pictorial 5-3 (Illustration Booklet, Page 35) and set the oscillator circuit board controls as follows:

- () TRANSMIT RETURN (R131) – 9 o'clock position.
- () HFO Level (R173) – 3 o'clock position.

HFO ALIGNMENT

During the alignment, you will use the two test wires that you prepared earlier.

Refer to Pictorial 5-3 (Illustration Booklet, Page 35) for the following steps.

- () Push the PCB connector on one end of the meter test lead (with an alligator clip on the other end) onto the circuit board pin at METER on the oscillator board.
- () Connect the alligator clip of this test wire to the positive (+) lead of your VTVM (or DVM). Then connect the negative or common lead of your meter to the Transceiver chassis.
- () Set your meter to measure 4-volts DC and turn the meter on.
- () Push the PCB connector on one end of the test lead (assembled earlier) onto the pin at RF.

When a test point is called out in a step, insert the bare end of the test lead wire into the wire socket at that test point on the circuit board.

- () Connect the Transceiver to a 12.6-volt DC source. Then turn the AF GAIN control on the Transceiver clockwise until it clicks on.
- () Connect the free end of the test lead wire to TP103 (near HFO Level control R173).

NOTES:

1. When you adjust the coils in the following steps, be careful not to exert any downward pressure on the slugs. Also do not turn the slugs more than two turns clockwise. Too much pressure, or turning the slug too far clockwise, could dislodge the slug from the coil.

2. Adjustments **must** be made in the following sequence for proper alignment. Use the small end of the red alignment tool to adjust each coil, in order, for a maximum reading on your meter (you may not have a reading when you start). Set the BAND switch to the band indicated for each adjustment. Some adjustments may seem very sharp; make them slowly and carefully. No coil should require more than 1-1/2 turns in either direction. Increase the range of your voltmeter as necessary. If you do not have the optional bands installed, omit the steps that have an asterisk.

	<u>BAND</u>	<u>ADJUST</u>
()	80	L124
()	40	L125
()	30*	L126
()	20	L127
()	17*	L128
()	15	L129
()	12*	L131
()	10*	L132

- () Repeat the preceding steps until no further increase is indicated on your meter. Then disconnect the RF wire and your meter, and return the BAND switch to the 80 Meter position.

VFO ALIGNMENT

- () Refer to Pictorial 5-2 (Illustration Booklet, Page 34) and use the blade of the shorter alignment tool to turn the trimmer of main tuning capacitor (C1) clockwise until it is just snug. Then turn the trimmer counterclockwise one full turn.
- () Position all wires in the area of the VFO circuit away from coil L118 and the VFO tuning capacitor.
- () Connect your frequency counter to test point TP102.

NOTE: The coil that you will adjust in the next step has been preset close to its correct setting at the factory. When you adjust this coil, be sure the slug remains in the lower half of the coil.

- () Set the Transceiver TUNING DIAL at the 250 mark and adjust L118 for a reading of 5.7493 MHz.
- () Turn the dial to the zero mark and adjust the trimmer of tuning capacitor (C1) for a reading of 5.9993 MHz.
- () Repeat the previous two steps until your frequency counter indicates exactly 5.7493 MHz with the dial at 250, and 5.9993 MHz at zero. Then disconnect your frequency counter.

TRANSMIT RETURN ADJUSTMENT

- () Set your VTVM or DVM to a 15 volt range and connect its positive (+) test lead to the lead of 33 k Ω resistor R127 nearest TRANSMIT RETURN control R131.
- () Make sure the CW LEVEL control (on the front panel) is fully counterclockwise, and the RIT control is in the detent at the center of rotation. Then note the voltage indication on your meter.
- () Key the transmitter by shorting the KEY input on the rear panel, or by holding down a regular key connected to the KEY input.
- () Adjust TRANSMIT RETURN control R131 until the transmit voltage equals the voltage you observed in the receive mode. Then disconnect your meter.

This completes the VFO alignment and Transmit Return adjustment. Proceed to "BFO Alignment."

BFO ALIGNMENT

Refer to Pictorial 5-3 (Illustration Booklet, Page 35) for the location of the test point and adjustment used in the BFO alignment.

- () Connect your frequency counter to TP104 on the upper right-hand side of the BFO shield.
- () Insert your alignment tool through the L135 access hole in the top of the BFO shield and into the core of L135.

- () Key the transmitter and adjust L135 for a frequency counter indication of 8.8307 MHz.
- () Unkey the transmitter and the frequency indication should be about 8.8314 MHz. Disconnect the frequency counter from TP104 and remove the alignment tool.

MIXER FILTER ALIGNMENT

- () Push the PCB connector on one end of the meter test lead (with an alligator clip on the other end) onto the circuit board pin at METER on the oscillator board.
- () Connect the alligator clip of this test lead to the positive (+) lead of your VTVM (or DVM). Then connect the negative or common lead of your meter to the Transceiver chassis.
- () Set your meter to measure 1.5 volts DC.
- () Push the PCB connector of the test lead onto the pin at RF and insert the bare end of the RF wire into the wire socket at TP101.

To align the mixer filters (L101 through L117), you will first adjust two coils for the 80 Meter band; L101 with the dial set at zero and L102 with the dial set at 250. Then you will repeat the two adjustments until the VTVM or DVM reading shows no further improvement before you proceed to adjust the next band. NOTE: The two readings on each band may or may not be the same.

Coils L101 through L106 will peak when the slugs are approximately 1/16" down from the top of the coil form. Coils L107 through L117 will peak with their slugs approximately 1/8" down. Preset these slugs in the following manner before you begin the filter alignment.

- () Insert the alignment tool into the slug of the coil and turn the slug counterclockwise until it is even with the top of the coil form. Then turn the slug clockwise two complete turns for 1/16" (L101 through L106), or four turns for 1/8" (L107 through L117).

NOTE: If you do not have the optional bands installed, omit the steps that are marked with an asterisk.

BAND	DIAL <u>0</u>	DIAL <u>250</u>	
80	() L101	() L102	() Repeat
40	() L103	() L104	() Repeat
30*	() L105	() L106	() Repeat
20	() L107	() L108	() Repeat
17*	() L109	() L111	() Repeat
15	() L112	() L113	() Repeat
12*	() L114	() L115	() Repeat
10*	() L116	() L117	() Repeat

This completes the alignment of the circuits on the oscillator circuit board. Disconnect the test leads. Then proceed with "T/R Board Adjustments."

T/R BOARD ADJUSTMENTS

RECEIVE IF ALIGNMENT

This adjustment is located on the transmit/receive (T/R) circuit board as shown in Pictorial 5-4 (Illustration Booklet, Page 35).

- () Connect a speaker to the SPEAKER jack on the rear panel, or connect headphones to the PHONES jack on the rear panel.
- () Use the alignment tool to turn the slug in transformer T301 for the loudest noise. Then turn the slug counterclockwise 1/4 turn. NOTE: You may have to use an external antenna to hear a noticeable change in the noise (this is a broad adjustment).
- () Adjust the AF GAIN control (on the front panel) until you hear noise in your speaker or headphones.
- () Adjust transformer T302 for the loudest noise.

AGC ADJUSTMENT

- () Observe the front panel meter and adjust METER ZERO control R333 until the meter pointer indicates zero.
- () Slowly adjust AGC SET control R329 counterclockwise until the meter pointer just indicates above zero. Then turn the control clockwise until the meter again indicates zero. Now turn the control about 1/8-turn further clockwise.
- () Turn the Transceiver off.

TRANSMIT BANDPASS ALIGNMENT

While you adjust the transmitter circuits in the following steps, we recommended that you connect a dummy load to the ANTENNA jack. This will reduce the possibility that you will cause interference on the air.

- () Connect a 50-ohm load to the ANTENNA jack on the rear panel.
- () Push the PCB connector on one end of the meter test lead (with the alligator clip on the other end) onto the pin marked "Meter" on the oscillator board. Then connect the alligator clip to the positive (+) lead of your VTVM or DVM.
- () Connect your meter's common or negative lead to the chassis and set the meter to measure 15 volts DC.
- () Push the PCB connector on one end of the test lead onto the pin marked "RF" on the oscillator board.
- () Insert the bare end of the RF wire into the wire socket at TP on the T/R circuit board.
- () Set the BAND switch to 80, the TUNING DIAL to 100, and the CW LEVEL control fully counterclockwise.
- () Turn the Transceiver on.
- () Key the transmitter as you observe your VTVM. If the meter indicates less than 1 volt, switch to a lower range or increase the CW LEVEL slightly. Then unkey the transmitter.

In the following steps you will adjust a pair of coils for each band. If you do not have the optional bands installed, omit the steps that have an asterisk.

Leave the dial set at 100 for all of these steps. Set the BAND switch as indicated, and then key the transmitter and adjust the listed coils alternately for a peak voltage reading. Repeat each step at least once until there is no further increase. Unkey the transmitter between steps while you change to the next band.

<u>BAND</u>	<u>ADJUST</u>
() 80	L401, L402
() 40	L403, L404
() 30*	L405, L406
() 20	L407, L408
() 17*	L409, L411

NOTE: For access to the 15-meter band coils, you must remove the shaft from the BAND switch. To do this, Refer to Detail 5-4A and perform the following steps.

- () Turn the Transceiver off.
- () Turn the BAND switch to 15 and loosen the setscrew in the collar on the bandswitch shaft.
- () Carefully slide the shaft part way out through the front panel and remove the collar from the shaft. Then slide the shaft out until coils L412 and L413 are exposed.
- () Turn the Transceiver on.
- () Adjust L412 and L413 for a maximum reading on your meter.
- () Reinsert the bandswitch shaft all the way into the wafers. Do not reinstall the collar yet.

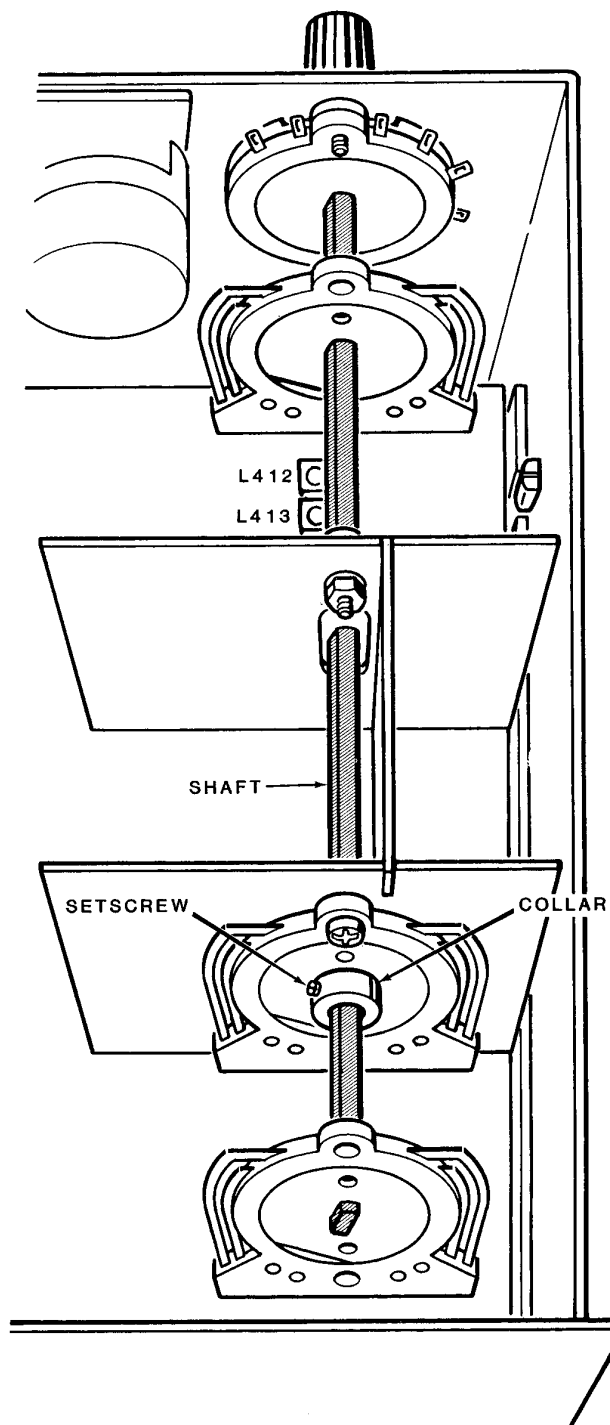

Detail 5-4A

Heathkit®

NOTE: If you do not have the accessory bands installed, omit the next two steps.

- () Turn the BAND switch to 12 and adjust L414 and L415 for a maximum indication on your meter.
- () Turn the BAND switch to 10 and adjust L416 and L417 for a maximum indication.
- () Turn the BAND switch to 80.

In the following steps, you will readjust coils L401 through L417, in pairs, with the dial alternately set at 250 and zero. For each step, select the band and set the dial at 250. Then key the transmitter and adjust the indicated coil. Change the dial to zero, key the transmitter, and adjust the second coil of the pair. Repeat the step until your meter readings are as high as possible and the two readings are nearly equal before you perform the next step. If the two readings are not close when you finish adjusting them, adjust the coil at the end of the band that produced the higher reading for a slightly lower reading (at its end of the band). Then readjust the other coil at the end of the band that produced the lower reading. When the readings at both ends of the band are nearly equal, proceed to the next step. Omit the steps that have an asterisk if you do not have the accessory bands installed.

BAND	DIAL 250	DIAL 0	
80	() L402	() L401	() Repeat
40	() L404	() L403	() Repeat
30*	() L406	() L405	() Repeat
20	() L408	() L407	() Repeat
17*	() L411	() L409	() Repeat

- () Turn the BAND switch to 15 and slide the band switch shaft out through the front panel to expose coils L413 and L412.

15 () L413 () L412 () Repeat

- () Turn the Transceiver off.

- () Reinsert the bandswitch shaft into the switch wafers, with the collar on the shaft as shown. Press the collar against the wafer and tighten the setscrew.

- () Turn the Transceiver on.

12* () L415 () L414 () Repeat

10* () L417 () L416 () Repeat

- () Disconnect the test leads from the Transceiver.

This completes the bandpass alignment. Proceed to "BFO Filter adjustment."

BFO FILTER ADJUSTMENT

- () Set the BAND switch to 80 and the CW LEVEL control to the center of its rotation.

- () Key the transmitter and adjust the CW LEVEL control until you obtain a meter reading. Then adjust L137 (on the oscillator circuit board) until the front panel meter indicates as high as possible. Then adjust the coil in the opposite direction until the needle just starts to move down scale. Unkey the transmitter.

- () Turn the Transceiver off.

HFO LEVEL ADJUSTMENT

- () Tune in a clear signal on any band and set the AF GAIN control for a normal listening level.

- () Turn control R173 (on the oscillator circuit board) counterclockwise until the received signal disappears. Now turn the control clockwise until the signal reappears. Continue turning the control clockwise to a point where there is no further increase, and 1/8 turn beyond. NOTE: Do not turn this control any further clockwise than the 3 o'clock position (as viewed from the front of the control).

This completes the Alignment of your Transceiver. Proceed to "Final Assembly."

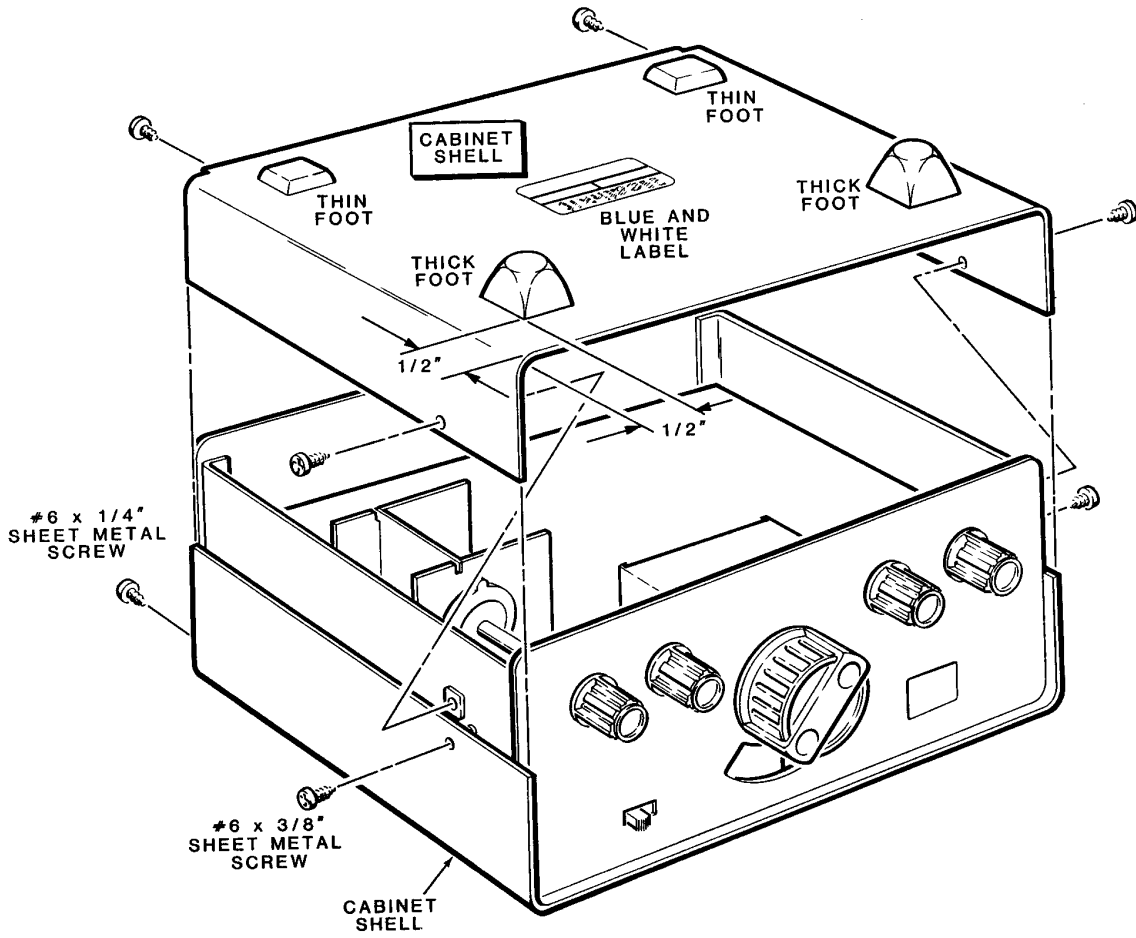

PICTORIAL 6-1

FINAL ASSEMBLY

Refer to Pictorial 6-1 for the following steps.

- () Position one of the cabinet shells onto the bottom of the chassis as shown in the Pictorial. Then use two #6 × 1/4" and two #6 × 3/8" sheet metal screws to secure the shell onto the chassis as shown. Use the #6 × 1/4" screws in the back edge of the cabinet shell and the #6 × 3/8" screws in the sides.
- () Carefully peel the backing paper from one of the thick feet. Then press the foot onto the bottom cabinet shell near one of the front corners as shown.
- () Similarly press a thick foot onto the bottom cabinet shell near the remaining front corner.
- () Similarly press thin feet onto the bottom cabinet shell near the two rear corners.
- () Carefully peel the backing paper from the blue and white label. Then press the label onto the bottom cabinet shell in the area shown. Be sure to refer to these numbers in any communications you may have with the Heath Company about your kit.
- () Turn the chassis over and install the remaining cabinet shell onto the chassis. Use two #6 × 1/4" and two #6 × 3/8" sheet metal screws. Use the #6 × 1/4" screws in the back edge of the cabinet shell and the #6 × 3/8" screws in the sides.

This completes the assembly and adjustment of your QRP Transceiver. Proceed to "Installation and Operation."

INSTALLATION AND OPERATION

This section of the Manual first describes the connections on the rear panel of your Transceiver and then describes the operation of the front panel controls. If you install and operate your unit as described, you will achieve the greatest satisfaction from your Transceiver.

REAR PANEL CONNECTIONS

Refer to Pictorial 7-1 (Illustration Booklet, Page 36) for the locations of the following rear panel connections.

GROUND

This binding post is provided so you can ground your Transceiver. Use #18 (or heavier) wire and connect it securely to a grounded water pipe or other earth ground. If you use a water pipe, be sure there are no plastic pipes or connectors between the Transceiver and the earth.

ANTENNA

This Transceiver will provide satisfactory results with almost any dipole or inverted vee antenna that has a 50- to 75-ohm impedance and a low VSWR. Such antennas are easy to construct from lightweight hookup wire, and they are inexpensive. However, antennas of the beam or quad type will provide a significant improvement in performance. An efficient antenna will produce more reliable and enjoyable contacts.

METER ZERO

This control is accessible through a hole in the rear panel and allows you to set the S-meter pointer to zero when no signal is being received.

MUTE DELAY

This control is accessible through a hole in the rear panel and allows you to set the delay between the time you release the CW key and the receiver unmutes.

SIDETONE LEVEL

This control is accessible through a hole in the rear panel and allows you to set the side tone to the desired level.

Heathkit®

Comprehensive reference material about antennas and transmission lines is presented in the ARRL Antenna Handbook and similar publications, available at most electronic hobby stores or public libraries.

Once you have selected and installed your antenna, connect its lead-in to the coaxial jack on the rear panel.

DC POWER

Your Transceiver is designed to operate from a 12.6-volt DC source such as the Heathkit Model PSA-9 Accessory Power Supply, an automobile battery, or other stable source that will supply 12.6 volts at 1 ampere. If you have the Model PSA-9 Power Supply, its output connector will plug directly into the DC POWER connector on the rear panel of your Transceiver.

For connection to a car battery or other 12.6-volt source, refer to Detail 7-1A and perform the following steps.

- () Locate the 2-pin plug shell and two female connector pins that were supplied with your Transceiver kit. Then cut the ears from the connector shell as shown.
- () Prepare a red wire and a black wire (preferably 16 gauge), long enough to reach from the Transceiver to your power source. Remove 1/4" of insulation from one end of each wire and install a female connector pin on the end of each as shown in the Detail.
- () Position the 2-pin plug shell with its point as shown; then insert the pin on the end of the black wire into the hole at the pointed end. The pin is properly seated when it snaps into the shell.
- () Similarly, insert the pin of the red wire into the other hole.
- () Twist the wires to form a 2-conductor cable. Then remove sufficient insulation from the end of each wire to attach whatever battery connectors you will use, or to connect the wires directly to your source terminals.

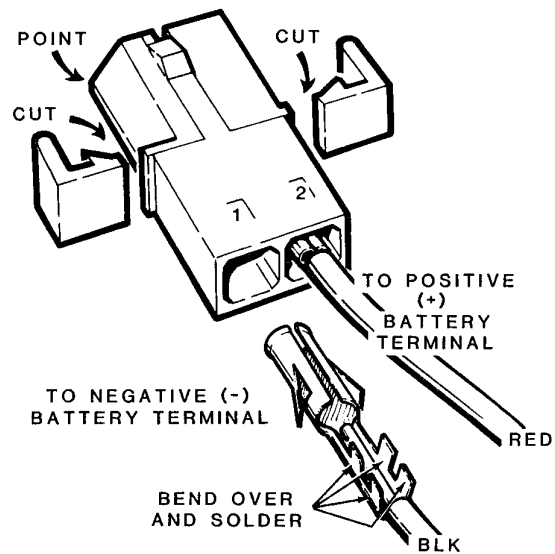

Detail 7-1A

- () Connect the black wire to the negative (-) source and the red wire to the positive (+) source.

CAUTION: Before you connect your power source to the Transceiver, recheck the connections to be sure the negative (-) source connects to the pointed end of the connector and the positive (+) source to the flat end. Reversed polarity will damage the Transistors in your Transceiver.

- () Plug the connector into the DC POWER connector on the rear of your Transceiver.

NOTE: If you use your Transceiver in a boat or car, keep the power supply leads as short as possible to help reduce ignition noises. You may need to install a "hash filter" if the interference is severe. The ARRL Handbook contains valuable information on noise filtering.

SPEAKER

For loudspeaker listening, connect a 4- to 8-ohm speaker to the SPEAKER socket on the rear panel.

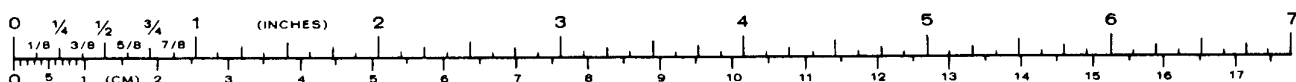

HEADPHONE

For headphone listening, plug your headphones into the HEADPHONE jack. The speaker is automatically cut off when a plug is inserted into the HEADPHONE jack.

KEY

Connect your telegraph key or keyer to the phono socket marked KEY. If one contact of your key connects to its frame, be sure to connect that lead to the outer shell of the phono jack. NOTE: There is a positive voltage present at this jack.

FRONT PANEL CONTROLS

Pictorial 7-2 (Illustration Booklet, Page 36) shows the front panel switches and controls, and briefly describes their function. The following paragraphs discuss the use of these controls in normal operation. As you read this discussion, set each switch and control to the indicated position. Be sure you have connected a power source to the DC POWER connector on the rear panel and have turned on the power source.

AF GAIN/OFF — Turns the Transceiver off and on and sets the audio level for comfortable listening.

Rotate the AF GAIN control clockwise to about the mid-point. You can readjust this control later if the audio level is too loud or too soft.

BAND switch — Selects the band for receiving and transmitting. These are the 80-, 40-, 20-, and 15-meter bands for the basic Transceiver, and also include the 30-, 17-, 12-, and 10-meter bands if you have the Model HWA-9 Accessory installed.

Set the BAND switch to the band you desire.

SELECTIVITY — Selects wide or narrow selectivity as an aid in tuning out unwanted signals on either side of the desired frequency.

Set the SELECTIVITY switch to WIDE for now. You can later change to NARROW to eliminate adjacent channel signals.

RIT — This control allows you to tune your receiver to a frequency that is up to 1 kHz above or below the transmitter frequency.

Set the RIT control to its midposition (detent).

TUNING DIAL — Selects the receive and transmit frequency. This dial is calibrated in divisions from 0 to 250, with each small mark indicating 5 kHz and each longer mark indicating 10 kHz. Thus, on the 80-meter band, for example, a tuning dial setting of zero corresponds to a frequency of 3.500 MHz, while one small division above zero corresponds to 3.505 MHz, etc.

Use the TUNING DIAL to tune in a station. Then calculate its frequency by adding the dial divisions to the band's base frequency.

RELATIVE SIGNAL — This meter is marked 0 to 60 and indicates relative signal level in S-units for received signals, and relative power when transmitting.

CW LEVEL — Adjusts the level of RF output supplied to the antenna.

Key the transmitter and adjust the CW LEVEL control to the point where the meter indication just stops increasing. Never, however, adjust this control so the RELATIVE SIGNAL meter indicates higher than 40. Then release the key. NOTE: An indication of 40 (half scale on 10 meters) results in rated power output (approximate).

Your Transceiver is now ready for "on-the-air" operation. Review the preceding operating control descriptions and become familiar with them by tuning in different stations and trying to make contact.

This completes the "Installation and Operation."

IN CASE OF DIFFICULTY

Begin your search for any trouble that occurs after assembly by carefully following the steps listed below in the "Visual Checks." After you complete the "Visual Checks," refer to the Troubleshooting Charts.

NOTE: Refer to the "Circuit Board X-Ray Views" (Illustration Booklet, Page 37) for the physical location of parts on the circuit boards.

VISUAL CHECKS

1. Recheck the wiring. Trace each lead with a colored pencil on the Pictorial as you check it. It is frequently helpful to have a friend check your work. Someone who is not familiar with the unit may notice something that you have consistently overlooked.
2. About 90% of the kits that are returned to the Heath Company for repair do not function properly due to poor connections and soldering. Therefore, you can eliminate many troubles by reheating all connections to make sure they are soldered as described in the "Soldering" section of the "Assembly Notes" on Page 6. Be sure there are no solder "bridges" between circuit board foils.
3. Check to be sure all transistors and diodes are in their proper locations. Make sure each lead is connected to the proper point. Make sure each diode band is positioned above the band printed on the circuit board.
4. Check electrolytic capacitors to be sure their positive (+) mark is at the correct position.
5. Check to be sure each IC is properly installed in its socket, and the pins are not bent out or under the IC. Also be sure the IC's are installed in their correct positions.
6. Check the values of the parts. Be sure in each step that you wired the correct part into the circuit, as shown in the Pictorial. It would be easy, for example, to install a 68 k Ω (blue-gray-orange) resistor where a 6800 Ω (blue-gray-red) resistor should be installed.
7. Check for bits of solder, wire ends, or other foreign matter which may be lodged in the wiring.
8. A review of the "Circuit Description" may also help you determine where the trouble is.

If you still have not located the trouble after the "Visual Checks" are complete, and a voltmeter is available, check voltage readings against those shown on the Schematic. Read the "Precautions for Troubleshooting" before you make any measurements. NOTE: All voltage readings were taken with a high impedance voltmeter. Voltages may vary as much as $\pm 20\%$.

NOTE: In an extreme case where you are unable to resolve a difficulty, refer to the "Customer Service" information inside the rear cover of this Manual. Your Warranty is located inside the front cover.

PRECAUTIONS FOR TROUBLESHOOTING

1. Use caution when you test IC and transistor circuits. Although they have almost unlimited life when used properly, they are much more vulnerable to damage from excessive voltage or current than other circuit components.
2. Be sure you do not short any terminals to ground when you make voltage measurements. If the probe should slip, for example, and short across terminals or voltage sources, it is very likely to cause damage to one or more IC's, transistors, or diodes.

CHECKING TRANSISTORS AND DIODES

SILICON BIPOLAR TRANSISTORS

To check a transistor accurately, you should use a transistor tester. However, if one is not available, you can use an ohmmeter to determine the general condition of any one of the bipolar transistors in this kit. The ohmmeter you use must have at least 1 volt DC at the probe tips to exceed the threshold of the diode junctions in the transistor you are testing. Most vacuum tube voltmeters meet this requirement.

To check a transistor with an ohmmeter, proceed as follows:

1. Remove the transistor from the circuit.
2. Set the ohmmeter to the $R \times 100$ range.
3. Connect one of the ohmmeter test leads to the base (B) of the transistor. Touch the other meter lead to the emitter (E) and then to the collector (C). Both readings should be the

same, but may be either high or low. If one reading is high and the other low, the transistor should be replaced. (Use the Identification Chart on Page 102 to identify the transistor leads).

4. Interchange the test leads and repeat step 3.

NOTE: In the unusual case when the readings are all low, or all high, no matter which ohmmeter lead is connected to the base, the transistor should be replaced.

MOSFETS

An insulated gate type MOSFET is used at Q107 on the oscillator circuit board. Usually, any defect in these devices is an internal short circuit between the source and one of the gates. You can check them in the circuit with a high impedance voltmeter (10 megohms or higher). An abnormally low source voltage may indicate an internal short circuit.

Heathkit®

DIODES

To check a diode, unsolder one end from the circuit board, pull the lead up and out of the circuit board hole, and proceed as follows:

1. Set the ohmmeter to the $R \times 1000$ range.
2. Connect one of the ohmmeter test leads to the lead at the cathode (banded) end of the diode. Connect the other test lead to the other diode lead. Note the meter reading. Then interchange the meter leads and take another reading. One reading should be high and the other low (at least 10:1). If both readings are either high or low, the diode should be replaced.

TROUBLESHOOTING CHARTS

The following chart lists problems and possible causes of some troubles you might encounter. If a particular part is mentioned (Q103 for example) as a possible cause, check that part and other components connected to it to see that they are installed

and/or wired correctly. Also check for solder bridge and poor connections in the surrounding area. It is also possible, on rare occasions, for a part to be faulty and require replacement.

CONDITION	POSSIBLE CAUSE
-----------	----------------

RIT Problem

No control of RIT.	<ol style="list-style-type: none"> 1. Q103, Q104. 2. Diode D118. 3. Broken wire or poor connection to RIT control or points D or C on the oscillator board.
--------------------	--

S-Meter and Power Indicator Problems

RF out but no power reading, S/Units okay.	<ol style="list-style-type: none"> 1. Missing jumper at W415. 2. D408.
No S/Units or power reading, Transceiver operates okay.	<ol style="list-style-type: none"> 1. Q302. 2. No 9-volt supply to Q302. 3. Meter wiring.
No S/Units reading, Transceiver operates okay.	<ol style="list-style-type: none"> 1. D306.

Sidetone Problems

No sidetone, receiver okay.	<ol style="list-style-type: none"> 1. U304 not seated in socket. 2. D312. 3. Shorted cable, sidetone out. 4. Setting of Sidetone Level control (R368).
-----------------------------	--

General Receiver Problems

No audio output, sidetone present, transmit okay but meter not working in receive.	<ol style="list-style-type: none"> 1. U301. 2. AGC (pin 5 of U301) too high. 3. AGC Threshold (R329) misadjusted. 4. U302, Q301, D301, D302. 5. No R12 Volts on D301. (Q407, Q408). 6. L308 open.
No audio output, sidetone present, transmits okay, meter okay in receive.	<ol style="list-style-type: none"> 1. U303, U304. 2. Shorted cables to Selectivity switch.
No audio or sidetone, meter okay in transmit and receive.	<ol style="list-style-type: none"> 1. U303, U306. 2. Phone jack wiring, cables shorted.
Weak or low audio on all bands, transmits okay.	<ol style="list-style-type: none"> 1. D301, D302, open L303. 2. Q301, U301, FL301. 3. T404 incorrectly wired or shorted. 4. D403, D404, D407. 5. AGC (R329) misadjusted.
Poor receiver sensitivity.	<ol style="list-style-type: none"> 1. Q107. 2. Q301.

General Transmitter Problems

Low or no RF output on all bands, receive and sidetone okay.	<ol style="list-style-type: none"> 1. CW Level control wiring. 2. Low or no TX Out from BFO (see "BFO Problems"). 3. D401, D402, L421. 4. Q401 through Q406.
No RF output or sidetone, receive okay.	<ol style="list-style-type: none"> 1. Q408. 2. No T12 volt supply. 3. Wiring at Key jack or T/R board. 4. Broken lead in key cable.

Transmit and Receive Problems

No transmit or receive on any band, sidetone okay.	<ol style="list-style-type: none"> 1. 9-volt supply, U402. 2. Antenna or cable connection. 3. Bandswitch wafer misaligned. 4. No HFO output (See "HFO Problems"). 5. Q101, Q107. 6. No BFO output (See "BFO Problems"). 7. Mixer filters.
No transmit or receive – one band.	<ol style="list-style-type: none"> 1. HFO oscillator, mixer filter. 2. Band switch or switched 9-volt supply to oscillator. 3. Bandpass filter misaligned.

HFO Problems

No HFO signal, 80, 40, 30*, 20-meter bands.	<ol style="list-style-type: none"> 1. D121 through D128. 2. Q108. 3. Jumpers W101, W102.
No HFO signal, 17*, 15, 12*. 10-meter* bands.	<ol style="list-style-type: none"> 1. D129 through D137. 2. Wrong value capacitors at Q109. 3. Q109. 4. Jumper W104.
No HFO signal on any band.	<ol style="list-style-type: none"> 1. Q111. 2. Open L133. 3. R173 misadjusted.
No HFO signal, one band.	<ol style="list-style-type: none"> 1. Switched 9-volt supply. 2. Diode in defective circuit. 3. Misaligned oscillator tank circuit.

VFO Problems

No VFO output.	<ol style="list-style-type: none"> 1. Q102, Q105, Q106. 2. L118 installed incorrectly. 3. Wrong values, C182 through C187. 4. VFO C1 not connected to hole E, or shorted to shield.
----------------	---

BFO Problems

No BFO signal at TP104.	<ol style="list-style-type: none"> 1. Q112, Q113. 2. D142.
No TX/out signal, okay at TP104.	<ol style="list-style-type: none"> 1. Q114, Q115. 2. D143. 3. CW Level control miswired. 4. No + T12 volts on CW Level control.
Improper or no transmit shift.	<ol style="list-style-type: none"> 1. L134 open. 2. D141. 3. Wrong value of C205.

* WARC bands are part of the Model HWA-9 Accessory.

Mixer Filter Problems

No signal output at INJ/OUT.	<ol style="list-style-type: none">1. Shorted cable to INJ/OUT.2. Q101.3. D101 through D117.
No signal, one band.	<ol style="list-style-type: none">1. Improper alignment.2. Defective filter.3. Solder bridge on coil.4. Diode in defective band.

SPECIFICATIONS

GENERAL

Frequency Readout	Analog dial.
Readout Accuracy	5 kHz divisions.
VFO Frequency Tuning Bandwidth	250 kHz minimum.
Tuning Backlash	Less than 100 Hz.
Frequency Tuning Rate	Approximately 40 kHz per knob revolution.
Frequency Coverage	3.5 MHz – 3.75 MHz.
	7.0 MHz – 7.25 MHz.
	*10.0 MHz – 10.25 MHz.
	14.0 MHz – 14.25 MHz.
	*18.0 MHz – 18.25 MHz.
	21.0 MHz – 21.25 MHz.
	*24.750 MHz – 25.0 MHz.
	*28.0 MHz – 28.25 MHz.
Frequency Stability	Less than 150 Hz per hour after 30-minute warmup.
Power Requirement	11 – 16 VDC at 1 ampere (12.6 V specified).

* WARC bands are part of the Model HWA-9 Accessory.

Operating Temperature Range	0° to 40° C. All specifications referenced to 12.6 VDC at 25° C.
Front Panel Meter	Relative S-units in receive, relative power in transmit.
Modes – Transmit/receive	CW only.
Front Panel Controls	AF Gain with power off/on, Band switch, RIT control, Audio Filter wide/narrow, CW Level (drive), Main Tuning.
Rear Panel Connections	DC Power, Speaker, Headphones, Antenna, Key, Ground.
Optional Accessories	Model PSA-9 Accessory Power Supply. Model HWA-9 Accessory Band Pack.
Dimensions	4-1/4" H × 9-1/4" W × 8-1/2" D (10.8 × 23.5 × 21.6 cm).
Weight	4.7 lbs (2.1 kg).

RECEIVER

Sensitivity	Less than .5 μ V for 10 dB S+N/N. Less than .2 μ V for readable signal.
Selectivity, CW Audio Filter	Narrow – 250 Hz maximum at 6 dB. Wide – 1 kHz maximum at 6 dB.
Passband Center Frequency	700 Hz (approximate).
Audio Output	1 watt into 8-ohm load.
Dynamic Range	85 dB, measured in the Narrow filter mode.
Image rejection	60 dB minimum.
IF Rejection	60 dB minimum.
Internally Generated In-Band Spurious	Typically below 2 μ V except at 3.695, 7.166, 10.150, 14.041, 14.083, 21.195, 21.249, 28.089, and 28.093 MHz.
Audio Hum and Noise	At least 60 dB below maximum output.
RIT	\pm 1 kHz.

TRANSMITTER

RF Output Power	CW, 4 watts on all bands except 3 watts on 10 meters.
Transmitter Frequency Offset	700 Hz lower on all bands (approximate).
Antenna Load Impedance	At least 90% of rated power with less than 2:1 SWR. Protected against high SWR.
Harmonic Radiation	- 35 dB minimum, at rated output.
Spurious Radiation	- 40 dB minimum, at rated output.
T/R Operation	CW : Full break-in.
CW Sidetone	700 Hz (approximate) to speaker or headphones. Output level internally adjustable.

The Heath Company reserves the right to discontinue products and to change specifications at any time without incurring any obligation to incorporate new features in products previously sold.

CIRCUIT DESCRIPTION

Refer to the Schematic (fold-in) while you read the following information. The component numbers are arranged in the following groups to help you locate specific parts on the schematic, circuit boards, and chassis.

- 1 – 99 Parts mounted on the chassis.
- 101 – 299 Parts mounted on the oscillator circuit board.
- 301 – 599 Parts mounted on the T/R circuit board and the RF probe.

RECEIVER SIGNAL FLOW

During receive, the incoming signals that are present at the antenna connector pass through a low-pass filter on the T/R (transmit/receive) circuit board. The Band switch selects the proper filter, which rolls off the high frequencies on each band. A diode switch routes this filtered signal through a bandpass filter. The resulting signal is mixed with a pre-mix signal to produce an 8.83 MHz IF signal.

The 8.83 MHz IF signal is routed through another diode switch; then it is amplified and passed through a 4-pole IF filter. The signal is amplified again before it is routed to the product detector. An AGC (automatic gain control) voltage is produced at this point to keep the 2nd IF amplifier operating linearly.

The product detector converts the 8.83 MHz IF signal to audio frequencies, which then pass through either a wide or a narrow audio-active filter. An audio frequency amplifier then amplifies this filtered signal so it can drive an 8-ohm speaker or a set of headphones.

TRANSMITTER SIGNAL FLOW

Although the transmitter signals flow in a direction that is opposite to the receiver, the stages for both modes are very similar.

During CW transmissions, an 8.8307 MHz signal is coupled to the 2nd mixer where it is mixed with a pre-mix signal from the oscillator circuit board to produce the desired transmitter signal. This signal is then filtered by the same bandpass filters that are used during the receive mode before it is pre-amplified and applied to the power amplifier.

The power amplifier is made up of two transistors in parallel to produce an RF output signal. This signal is filtered by the proper low-pass filter for the selected band to reduce harmonic radiation before it is applied to the antenna.

The following sections describe the operation of each circuit in greater detail.

VFO

FET (field effect transistor) Q102 and its associated components make up a Hartley oscillator. Part of coil L118, Main Tuning capacitor C1, and fixed temperature-compensating capacitors C182 through C188 are used in the frequency-determining circuit of the VFO (variable frequency oscillator). The remaining part of L118 is used to couple back part of the generated signal to the drain (D) of Q102 to help sustain oscillation. The VFO generates frequencies between 5.9993 MHz and 5.7493 MHz.

Diode D119 clamps the positive-going half of the signal to prevent Q102 from reaching high peak operating currents. This helps to keep the VFO from generating harmonic signals.

The signal at the output of Q102 is coupled through C194 to the gate (G) of source follower Q105, which acts as a buffer and impedance-matching device. Q106 is a fixed-tuned amplifier that is followed by a low-pass filter, which reduces the harmonic output of the VFO. The VFO signal is then coupled to gate 1 (G1) of 1st mixer Q107.

RIT

The RIT circuit is in parallel with Main Tuning capacitor C1 of the VFO. This circuit, which is controlled by a +12 VDC switching voltage (+R in receive and +T in transmit) through Q103, causes a small change in the capacitance of D118 by varying the voltage across it. In the receive mode, RIT control R1 is used to vary this voltage, which results in a tuning range of ± 1 kHz (with respect to the receiver frequency). In the transmit mode, Transmit Return control R131 ensures that a constant voltage is applied across D118, regardless of the setting of the RIT control.

HFO

The HFO (heterodyne frequency oscillator) operates on any of eight crystal-controlled frequencies, depending on which band position is selected by Band switch SW1. The HFO signals for 80, 40, 30, and 20 meters are produced by Q108 and its associated circuitry. Q109 and its associated components produce the HFO signals for 17, 15, 12, and 10 meters.

The signal from either HFO transistor is coupled to the base of HFO emitter follower Q111. The HFO signal is then coupled through C175 to gate 2 (G2) of 1st mixer Q107.

1ST MIXER

Q107 produces the appropriate premix signal for the selected band by mixing the VFO and HFO signals. The premix signal is used in both the receive and transmit modes of operation.

PREMIX FILTERS

The unfiltered premix signal is applied to one of the eight diode switched filters and tuned circuits selected by Band switch SW1. The selected filter suppresses all unwanted signals; only the desired premix signal passes through C101 to the base of amplifier Q101. The filtered and amplified signal is then coupled through C103 to 2nd mixer U401 on the T/R circuit board. This circuit will be discussed later.

BFO

This circuit produces an 8.8314 MHz signal in the receive mode, while an 8.8307 MHz signal is generated in the transmit mode. To accomplish this task, Q112 is used in a VXO (variable crystal oscillator) circuit.

In the receive mode, crystal Y109, coil L135, and capacitors C206 through C208 determine the oscillator frequency.

D142 clamps the positive-going half of the signal to prevent Q112 from reaching high-peak operating currents. This helps to keep the oscillator from generating harmonic signals.

C211 couples the oscillator signal from the source (S) of Q112 to the base of emitter follower Q113, which acts as a buffer stage. Part of the signal from Q113 is coupled to product detector U303, which will be discussed later.

In the transmit mode, a +12 volt switching voltage (+T) is fed to resistor R151 to turn on D141. This allows the circuit, which is made up of L134 and C205, to produce a fixed offset frequency of 700 Hz

during transmit. At this time, emitter followers Q114 and Q115 are also turned on by the "+T" switching voltage. The 8.8307 MHz output signal at the emitter (E) of Q115 is coupled through C217, where its amplitude is controlled by CW Level control R2. This controlled level is coupled through C218 to a low-pass filter to suppress the harmonic output of the BFO. The filtered BFO signal is coupled to 2nd mixer U401.

2ND MIXER

U401 is a double-balanced mixer that is used in both the receive and transmit modes of operation.

In transmit, D303 is forward biased and the TX signal is fed from the BFO to U401, where the signal is mixed with the pre-mix signal supplied by Q101 on the oscillator circuit board. At the same time, a +12 volt switching voltage (+R) is removed from the anode end of D301 and D302, and "+T" applies a reverse bias voltage to these diodes.

The signal at the output (pin 1) of U401 is coupled through impedance-matching transformer T401 to the input of the selected bandpass filter (one of eight possible filters). A "+T" voltage is applied to the anode of D401, which permits the signal to be coupled to the base of Q401. At the same time, the "+T" voltage is also applied to the cathode of D403, which isolates the receive line from the transmit line.

From the emitter of amplifier Q401, the signal is fed to the base of amplifier Q402; and from Q402's emitter, the signal is applied to the base of driver Q404. At this time, keying transistor Q403 keeps Q404 turned on. Q404 amplifies the signal, couples it through impedance-matching transformer T402, and then applies the signal to the base of each of the two PA transistors, Q405 and Q406. Zener diode D405 prevents excessive RF voltages on the collectors of these transistors from destroying them under no-load and high-SWR conditions.

From the output of the PA transistors, the amplified RF signal is fed to matching transformer T403 and then coupled to the low-pass filter in use for that band. The resulting filtered signal is then applied to antenna jack J4.

In receive, the signals received by the antenna are coupled through the proper low-pass filter and C443. A "+R" voltage is applied to the anode of D404 and D407, which allow the signal to pass through matching transformer T404 and continue through the selected bandpass filter; thus taking the same path (but opposite direction) as the transmit signal to the 2nd mixer.

At the 2nd mixer, the receive signal is mixed with the pre-mix signal; thus, a resulting 8.83 MHz IF signal is coupled through switching diodes D302 and D301, which are forward biased by the "+R" voltage. This signal is now coupled through matching transformer T301 to the gate of common source IF amplifier Q301, which receives its operating voltage from the switched "+R" line. The resulting IF signal passes through FL301 and is further amplified by 2nd IF amplifier U301. From the output of U301, the amplified signal is coupled to matching transformer T302.

C327 couples a portion of the signal at the output of T302 to the AGC loop. This signal is now rectified by D309 and D311 and filtered by C328. The resulting negative voltage is fed to the input (pin 2) of AGC amplifier U302. A fixed positive reference voltage is applied to pin 3 of U302. When the strength of the signal that the transceiver is tuned to increases, the voltage at pin 2 of U302 decreases (goes more negative). This produces a higher positive voltage at the output (pin 6) of U302. As this voltage increases, D305 starts to conduct. This allows C317 to charge, resulting in a positive voltage being applied to pin 5 of 2nd IF amplifier U301; thus, the gain of U301 is reduced. R312 provides a discharge path for C317.

The amplified 8.83 MHz IF signal is coupled through C326 to the signal input (pin 4) of product detector U303. A signal from the BFO is coupled through C329 to the carrier input (pin 7) of U303. U303 mixes the two input signals and produces sum and difference signals at its output (pin 6). The sum frequency is filtered out by C334 through C336. The difference frequency is an audio signal.

Heathkit®

AUDIO CIRCUITS

After being filtered at the output of product detector U303, the audio signal is coupled to the inverting input (pin 6) of operational amplifier U304B. This stage makes up a low-pass filter with an approximate cutoff frequency of 1 kHz at the 6 dB point. The amplified audio signal at pin 7 of U304B is coupled through C347 to Selectivity switch SW3, and then through R352 and C339 to the input (pin 2 of U304A) of the audio-active filter.

In addition to U304A, U304C makes up the audio-active filter. These operational amplifier sections are cascaded and allow a certain amount of audio frequencies to pass through. The bandwidth for this filter is 300 Hz (between the 6dB points) at a center frequency of 700 Hz. This filter provides sharp selectivity and permits excellent rejection of unwanted, adjacent audio signals in the receive mode. The output of the audio-active filter is coupled through C346 to Selectivity switch SW3. The setting of this switch determines which signal is applied to AF Gain control R3.

The audio signal from the wiper arm of AF Gain control R3 is coupled through R369 to the input (pin 8) of audio power amplifier U306. A signal is coupled from the output (pin 8) of sidetone oscillator U304D to this input. In the transmit mode, Q303 mutes this input by connecting it to ground. The output signal from U306 is coupled through C359 to speaker J3 or phone jack J2.

KEYING CIRCUIT

Q407 through Q409 provide timing and switching of the receive and transmit functions in the Transceiver.

The keying circuit is made up of Q408 (+ T transmit request) and Q409 (+ R receive request). The outputs of these transistors are activated when the CW key is depressed. Q411 and Q412 in the receiver mute delay circuit are activated in the same manner.

When the key is depressed, the base of Q408 goes low. This causes it to conduct, thus establishing a

+ 12 volt output for the "+ T" request lines. At the same time, Q407 conducts and turns off Q409. C574 through C577 provide the proper timing of these lines as they are turned on and off.

RECEIVER MUTING

Q411 and Q412 provide a variable delay for the receiver muting circuit. The emitter of Q411 is connected to ground when the key is being depressed. This effectively puts the collector of Q411 at ground potential, causing mute drive transistor Q412 to conduct and provide +12 volts. The muting of the receive line ceases when the base voltage of Q412 reaches the +B voltage. R445 and C578 provide an adjustable time constant for the muting circuit.

SIDE TONE

When the key is depressed, pin 9 of sidetone oscillator U304D goes high and the oscillator is activated. The 700 Hz signal at the output (pin 8) of U304D is coupled through C351 and applied across Sidetone Level control R368. From the wiper of R368, the sidetone is coupled to the input (pin 8) of audio amplifier U306.

RELATIVE POWER

In the transmit mode, C568 couples a portion of the RF voltage across voltage divider R428 and R429. D408 rectifies the positive half cycle of the voltage across R429. C569 filters this positive voltage, which is coupled to meter M1 through current-limiting resistors R331 and R431.

S-METER



In the receive mode, D306 conducts when the AGC voltage across C317 exceeds a predetermined level. A portion of this voltage is coupled through R314 to the gate of Q302. The resulting, ramped voltage at the source of Q302 is coupled to meter M1 through current-limiting resistor R331. A regulated +9 volt supply powers the meter circuit. Meter zero control R333 allows you to set the meter to zero.

SEMICONDUCTOR IDENTIFICATION CHARTS

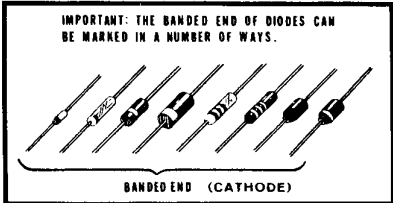
DIODES

CIRCUIT COMPONENT NUMBER	HEATH PART NUMBER	MAY BE REPLACED WITH	IDENTIFICATION
D307, D308, D309, D311	56-20	1N295A	 <p>IMPORTANT: THE BANDED END OF DIODES CAN BE MARKED IN A NUMBER OF WAYS.</p> <p>BANDED END (CATHODE)</p>
D119	56-24	1N458	
D138, D139	56-26	1N191	
D405	56-55	1N4753A	
D141, D142, D303, D305, D306, D312, D401, D402, D403, D404, D406, D407, D408	56-56	1N4149	
D101, D102, D103, D104, D107, D108, D112, D113, D121, D122, D123, D124, D127, D128, D132, D133, D143, D301, D302	56-646	BA-244	
D409	57-27	1N2071	
D118	57-65	1N4002	

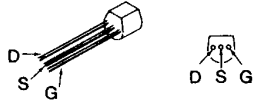
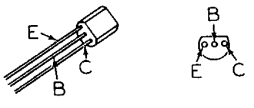
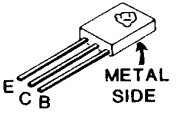
TRANSISTORS

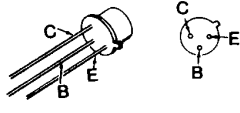
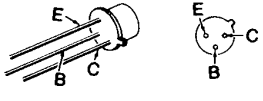
CIRCUIT COMPONENT NUMBER	HEATH PART NUMBER	MAY BE REPLACED WITH	IDENTIFICATION
Q102, Q105, Q112, Q301, Q302	417-169	MPF105	
Q401, Q402	417-172	MPS6521	
Q407, Q412	417-201	X29A829	
Q106	417-234	2N3638A	
Q101, Q108, Q109, Q111	417-293	2N5770	
Q103, Q104, Q113, Q114, Q115, Q303, Q411	417-801	MPSA20	
Q408, Q409	417-819	MJE171	
Q107	417-863	MFE131	
Q404	417-205	2N3866	
Q405, Q406	417-912	MRF237	

INTEGRATED CIRCUITS (IC'S)

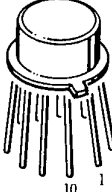
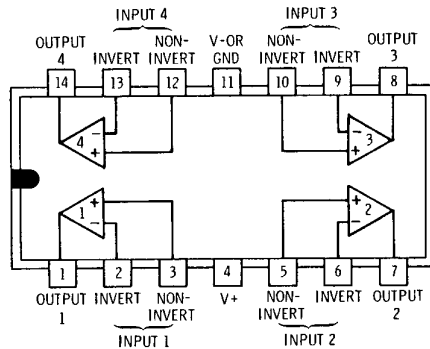
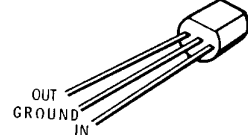
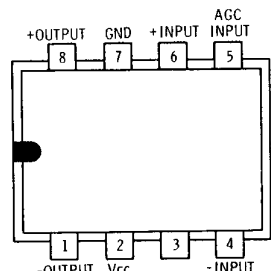
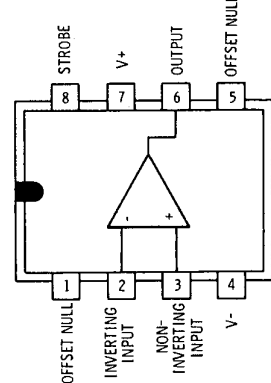
CIRCUIT COMPONENT NUMBER	HEATH PART NUMBER	MAY BE REPLACED WITH	IDENTIFICATION (TOP VIEW)
U303	442-96	MC1496G	
U304	442-602	LM324N	
U402	442-681	78L08	
U301	442-55	MC1349P	
U302	442-715	CA3130	

CIRCUIT COMPONENT NUMBER	HEATH PART NUMBER	MAY BE REPLACED WITH	IDENTIFICATION (TOP VIEW)
U306	442-763		

ILLUSTRATION BOOKLET

Part of 595-3059

Oscillator Circuit Board Parts Pictorial

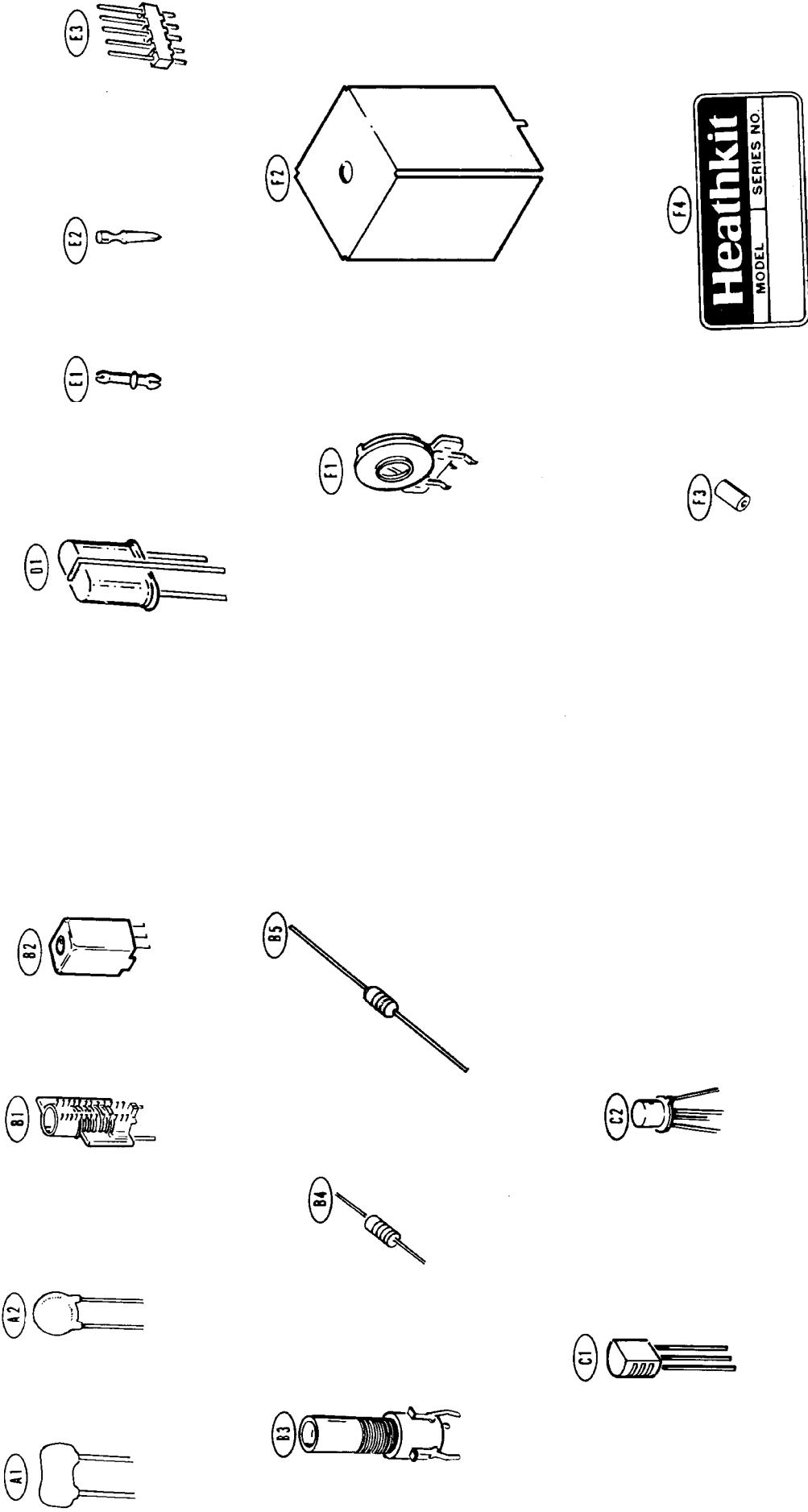

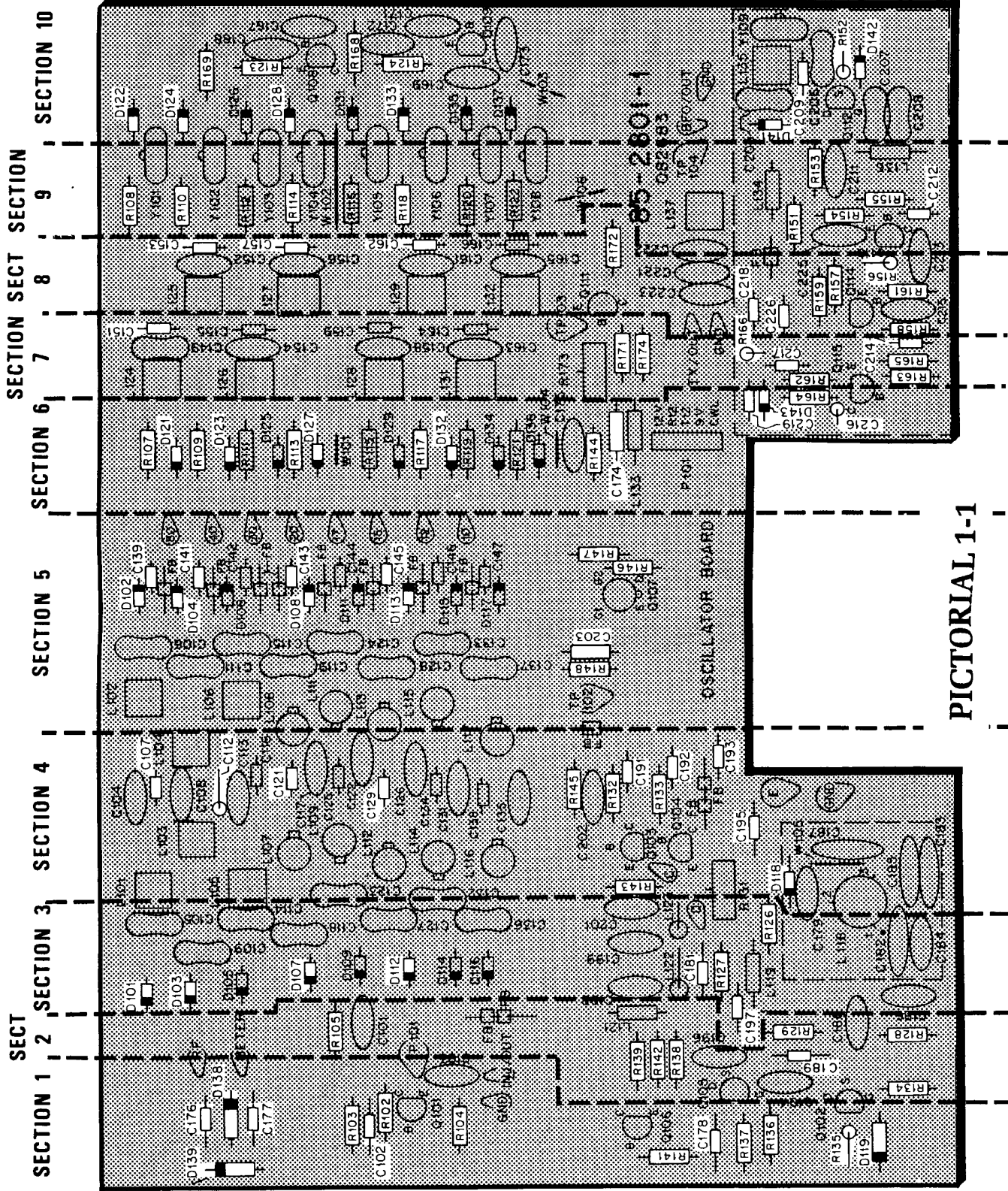

PICTORIAL 1-1

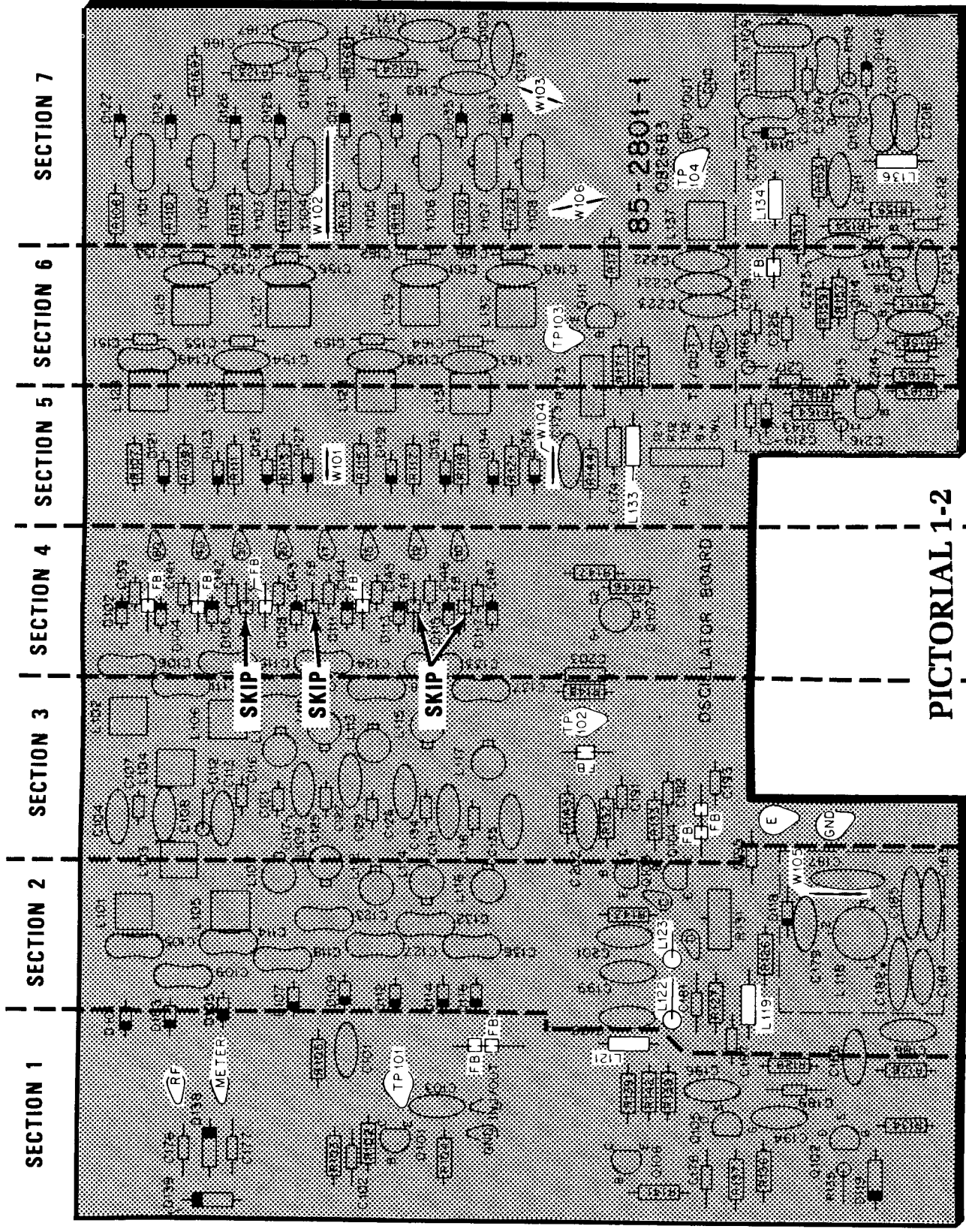

SECTION 1

SECTION 2

SECTION 3

SECTION 4

SECTION 5

SECTION 6

SECTION 7

SKIP

SKIP

SKIP

PICTORIAL 1-2

85-2801-1

SECTION 1 SECTION 2 SECTION 3 SECTION 4 SECTION 5 SECTION 6

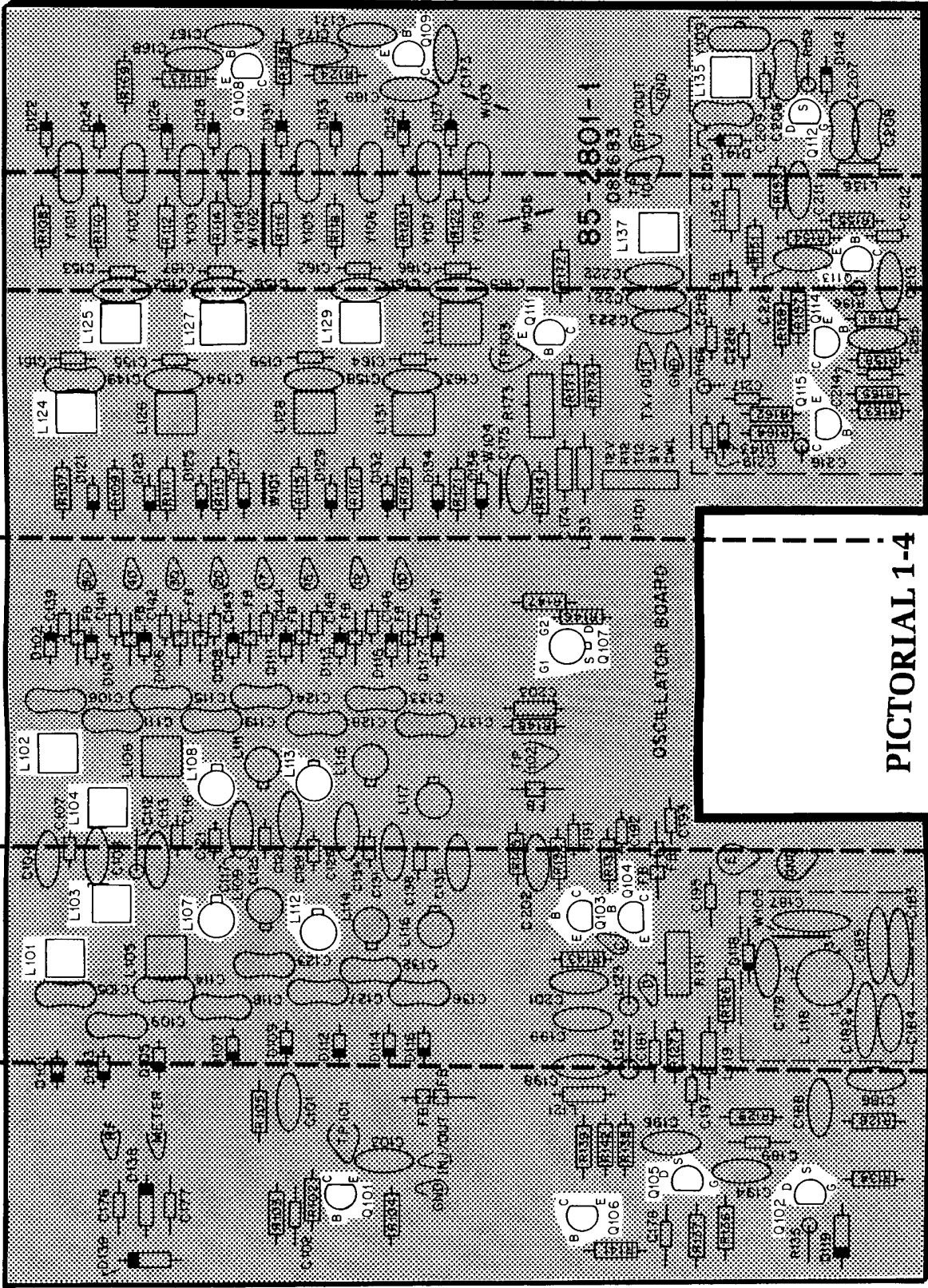

PICTORIAL 1-4

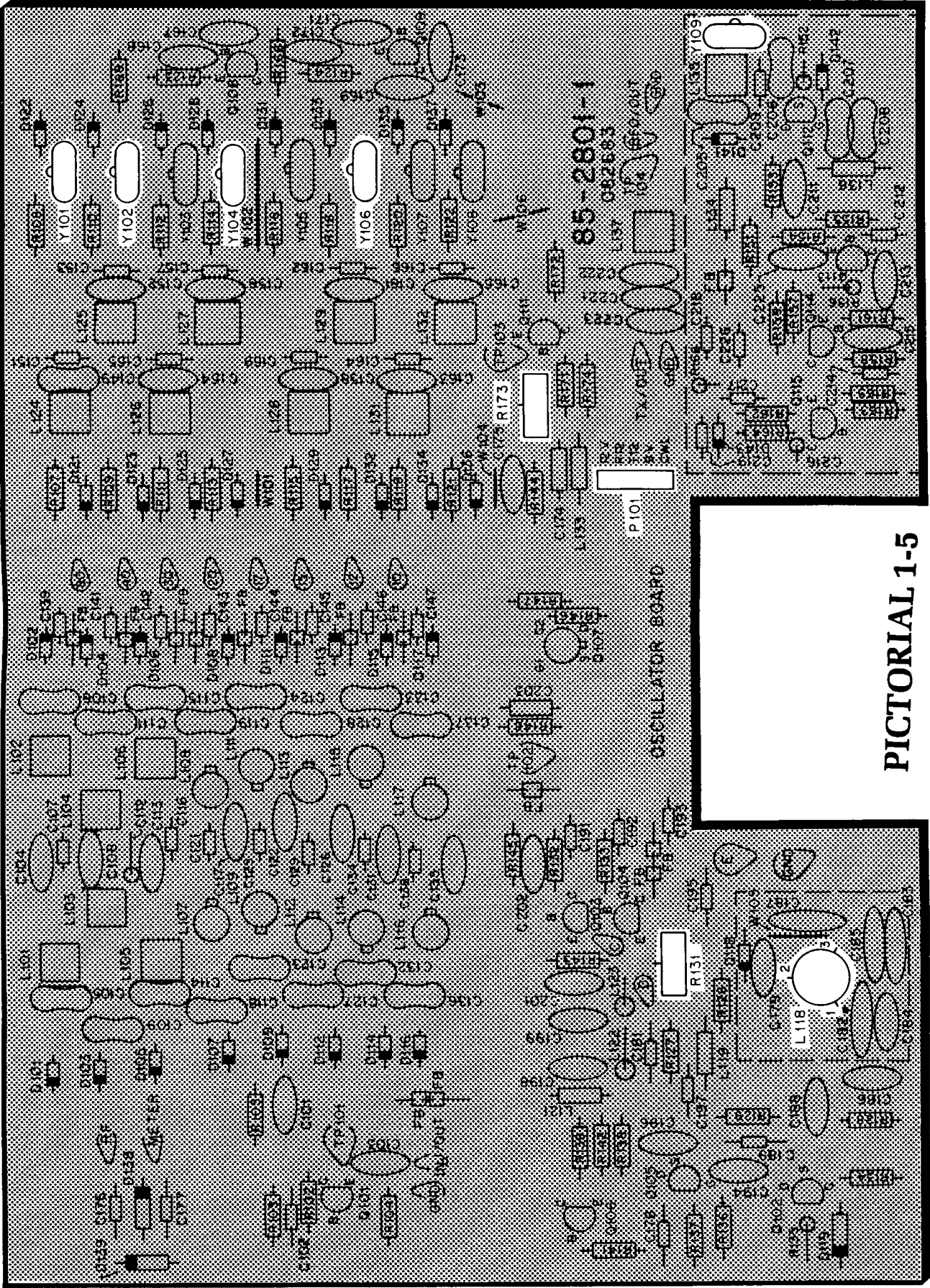

PICTORIAL 1-5

T/R Circuit Board Parts Pictorial

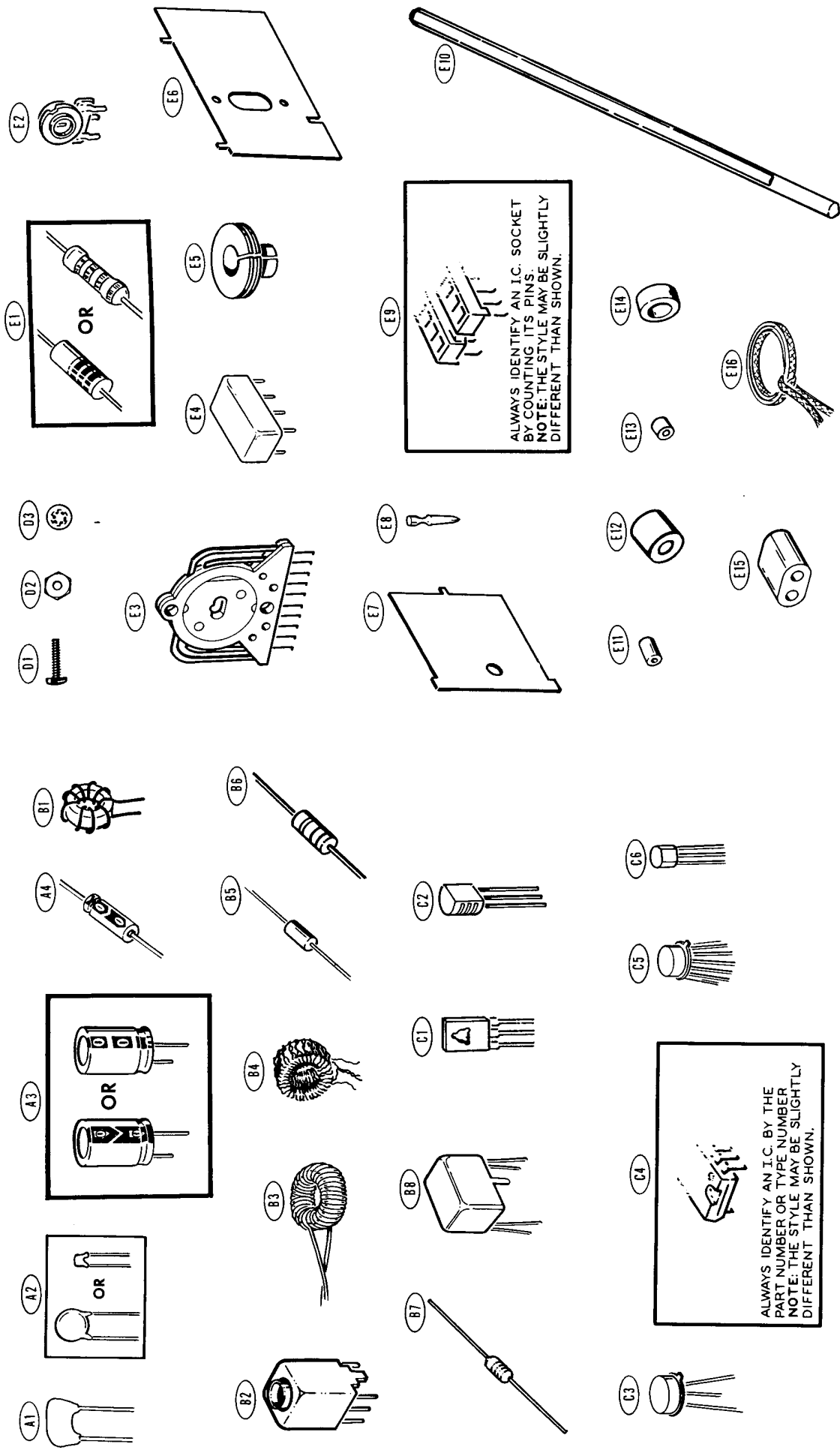

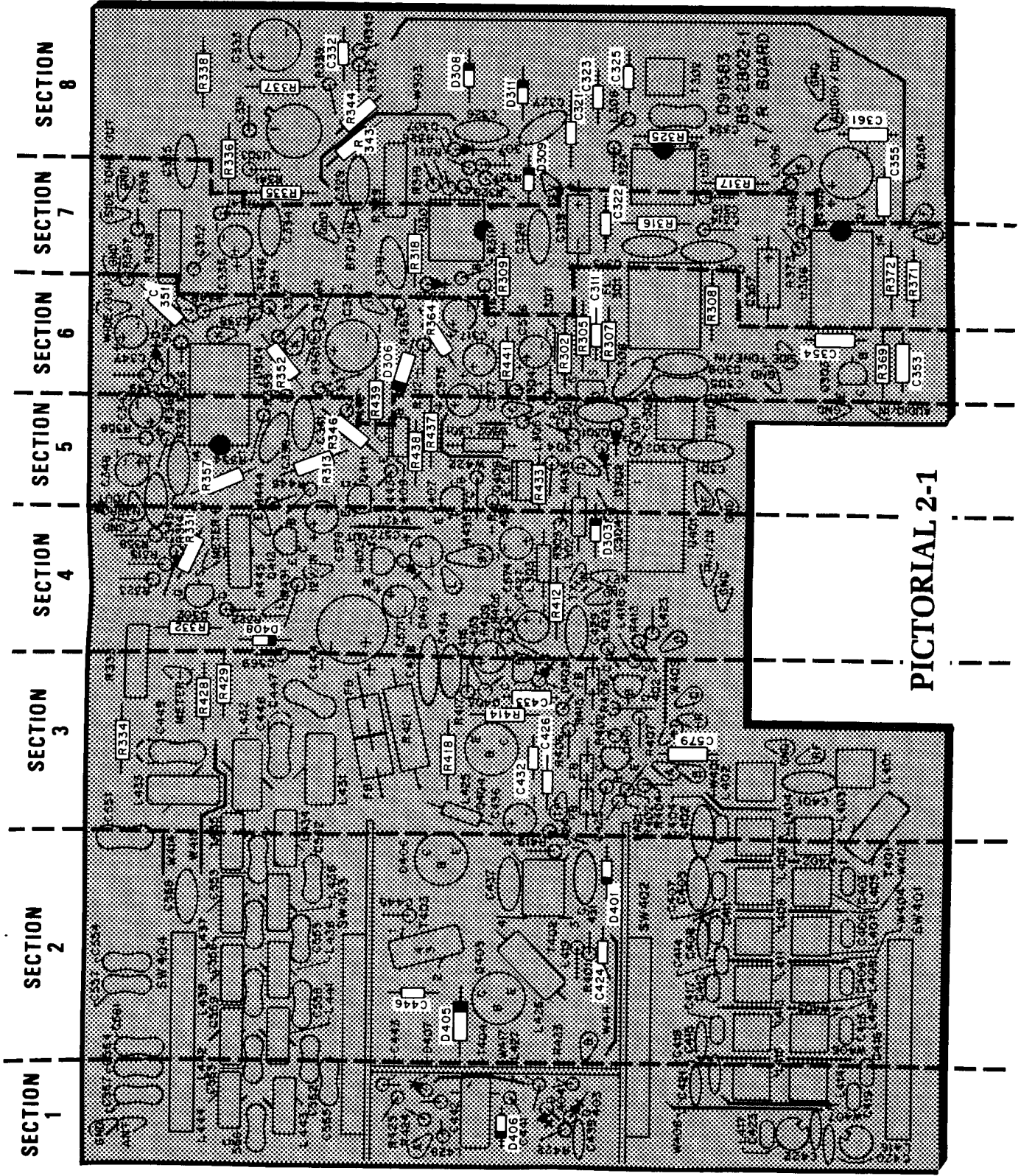

PICTORIAL 2-1

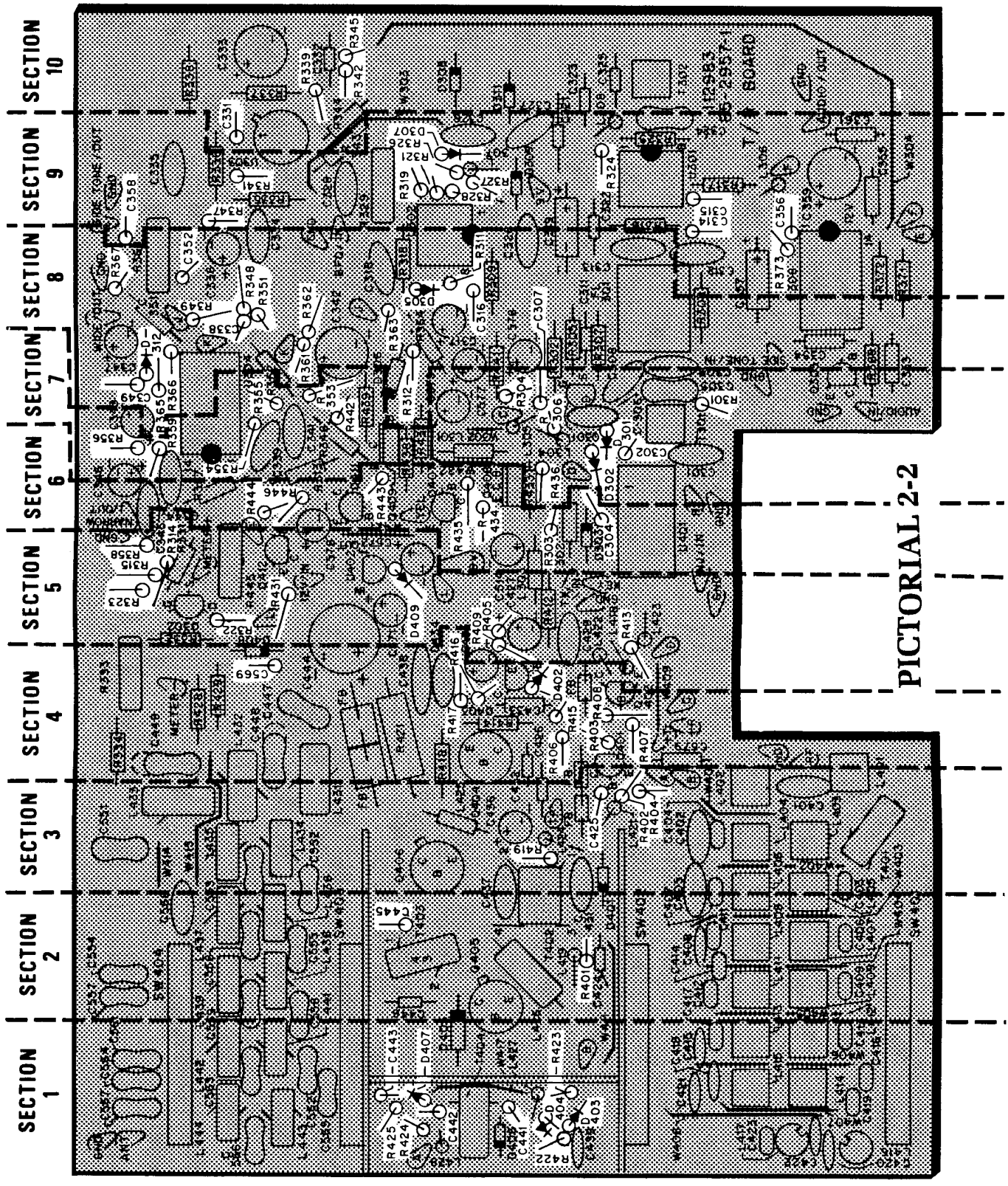

SECTION 1

SECTION 2

SECTION 3

SECTION 4

SECTION 5

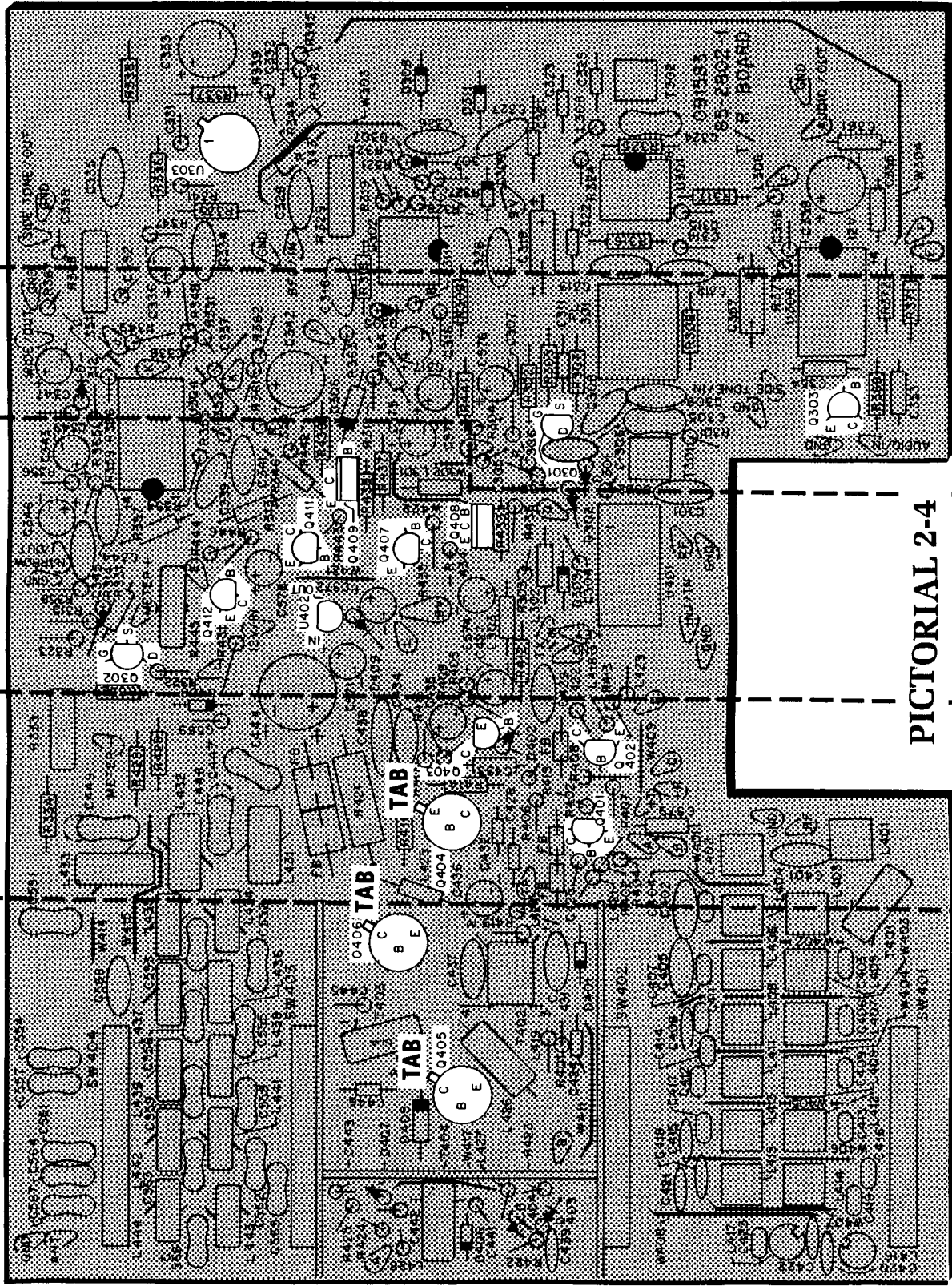

PICTORIAL 2-4

SECTION 1

SECTION 4

SECTION 5

SECTION 6

SECTION 7

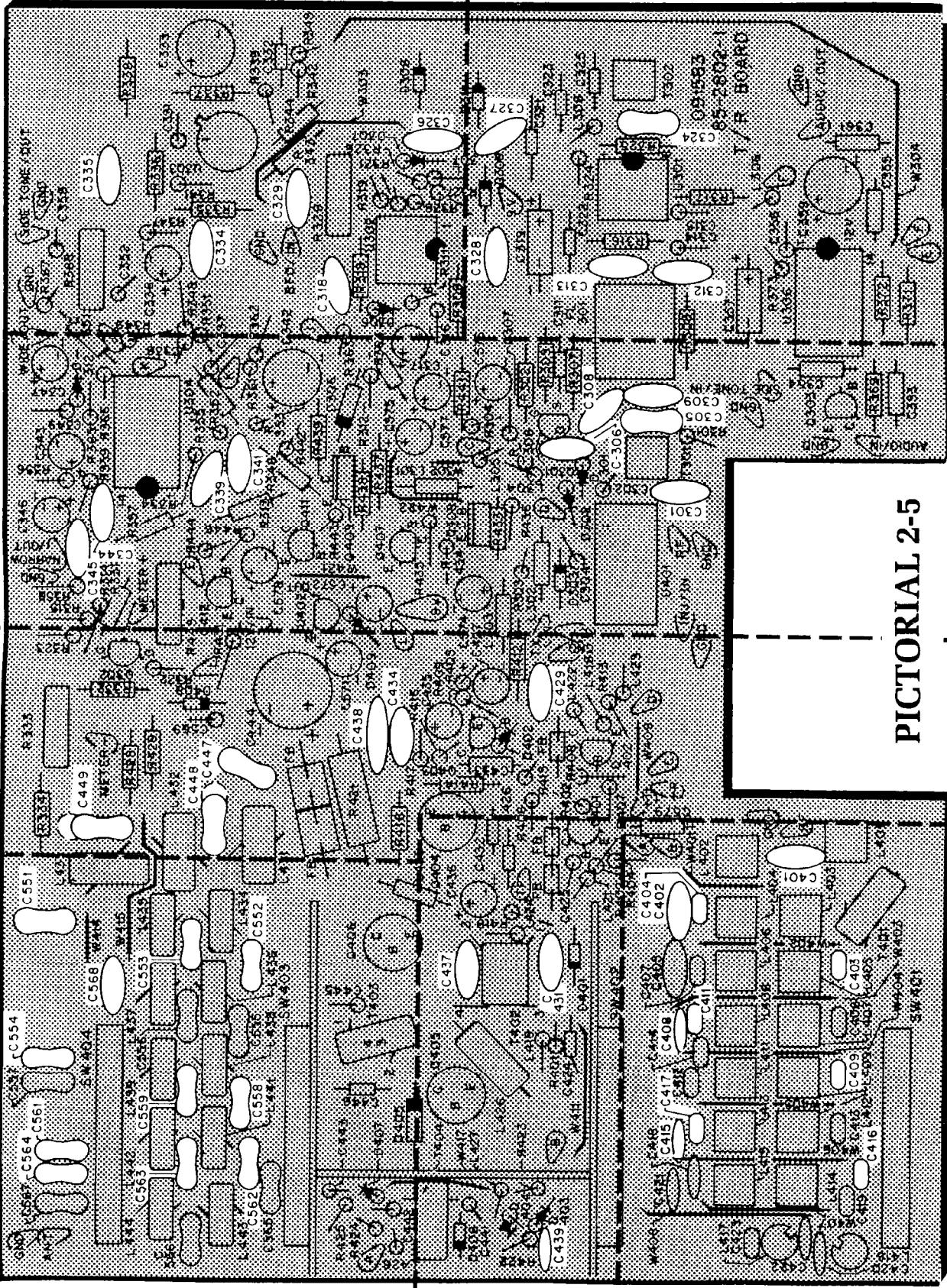

SECTION 2

SECTION 3

PICTORIAL 2-5

SECTION 1

SECTION 2

SECTION 3

SECTION 4

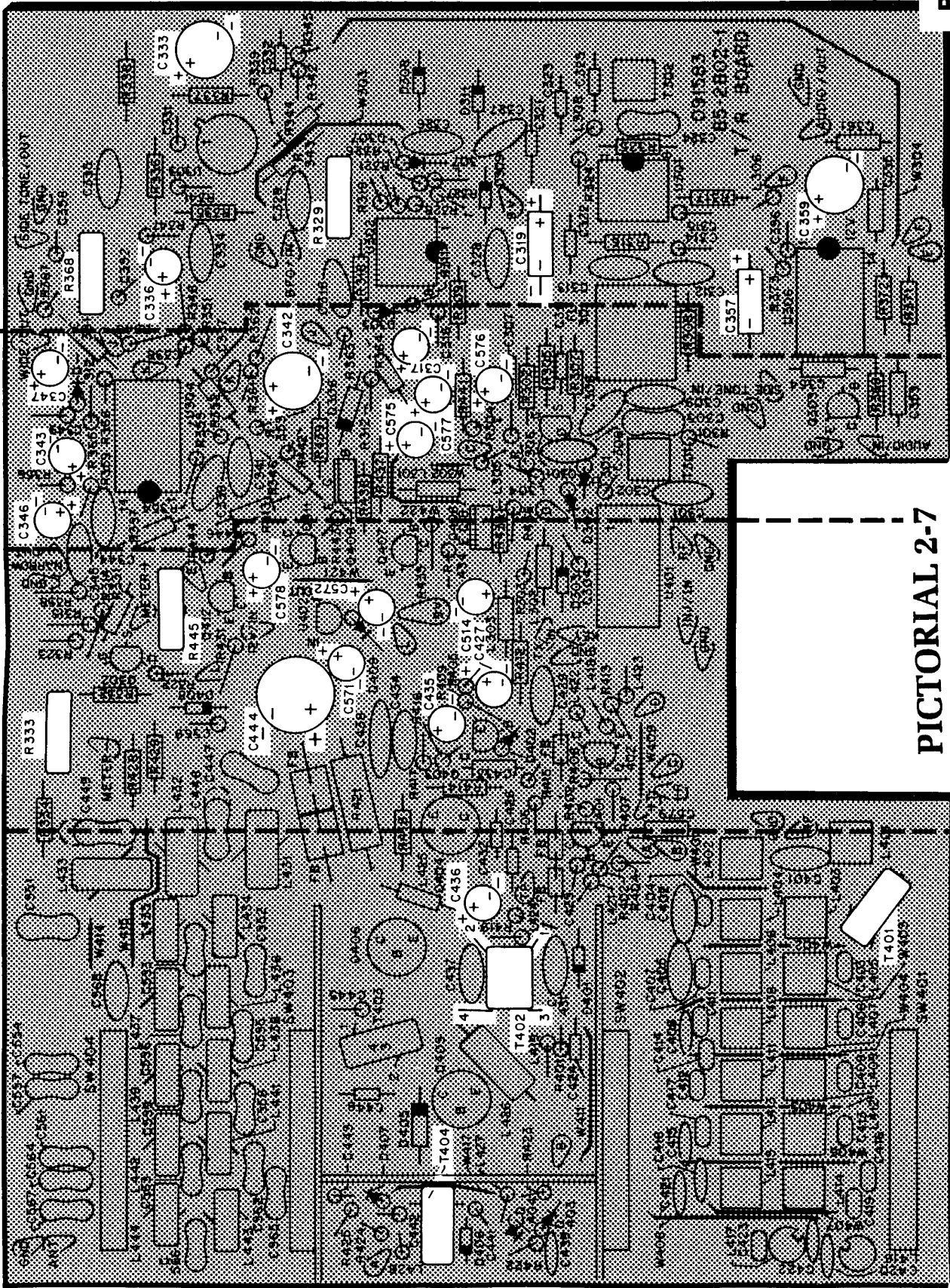

PICTORIAL 2-7

PART A

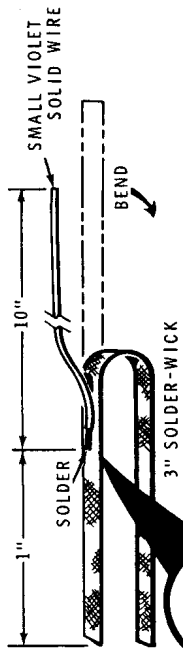

PART B

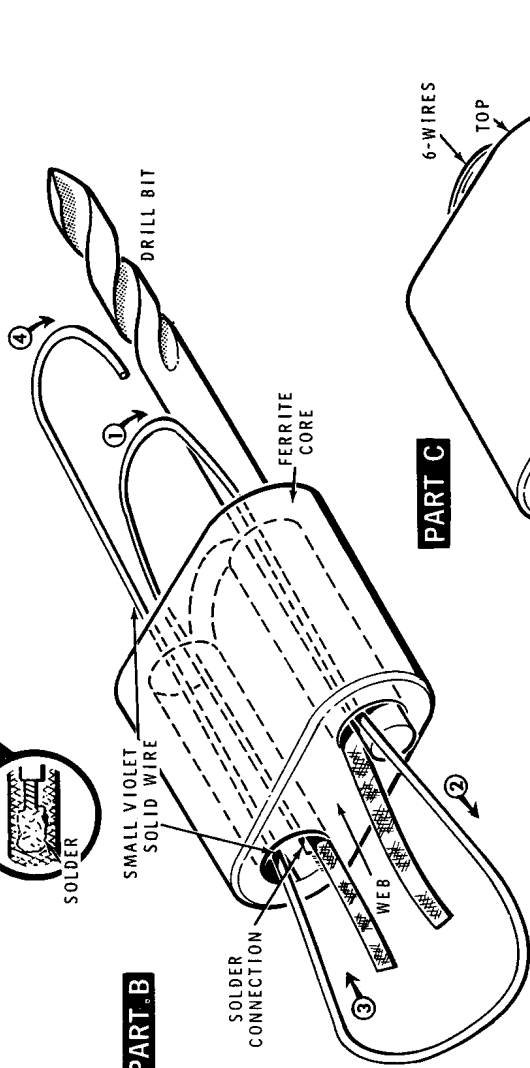

PART C

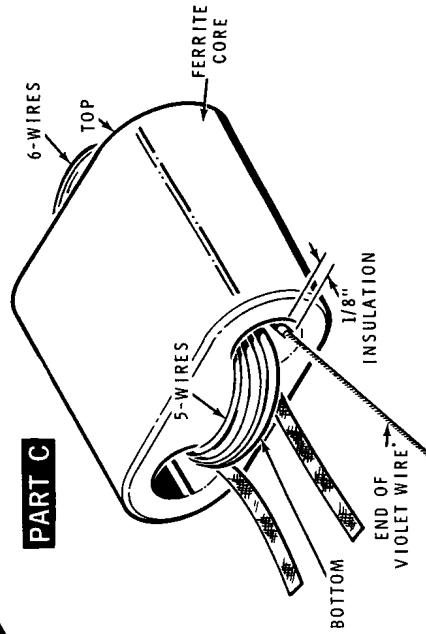

Detail 2-7A

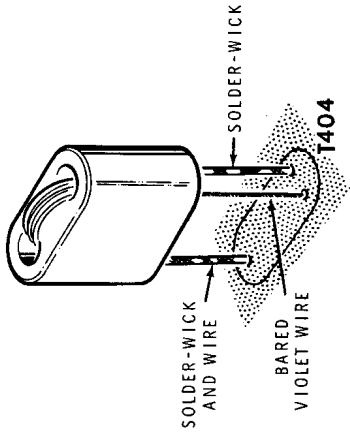

Detail 2-7B

PART A

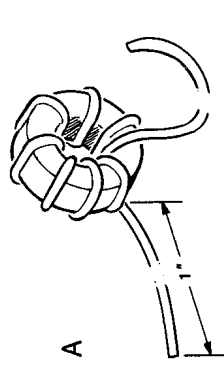

PART B

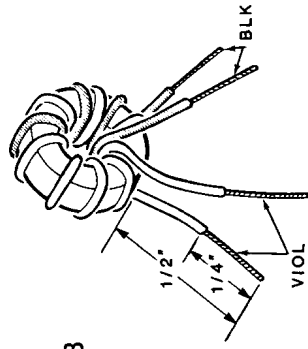

Detail 2-7C

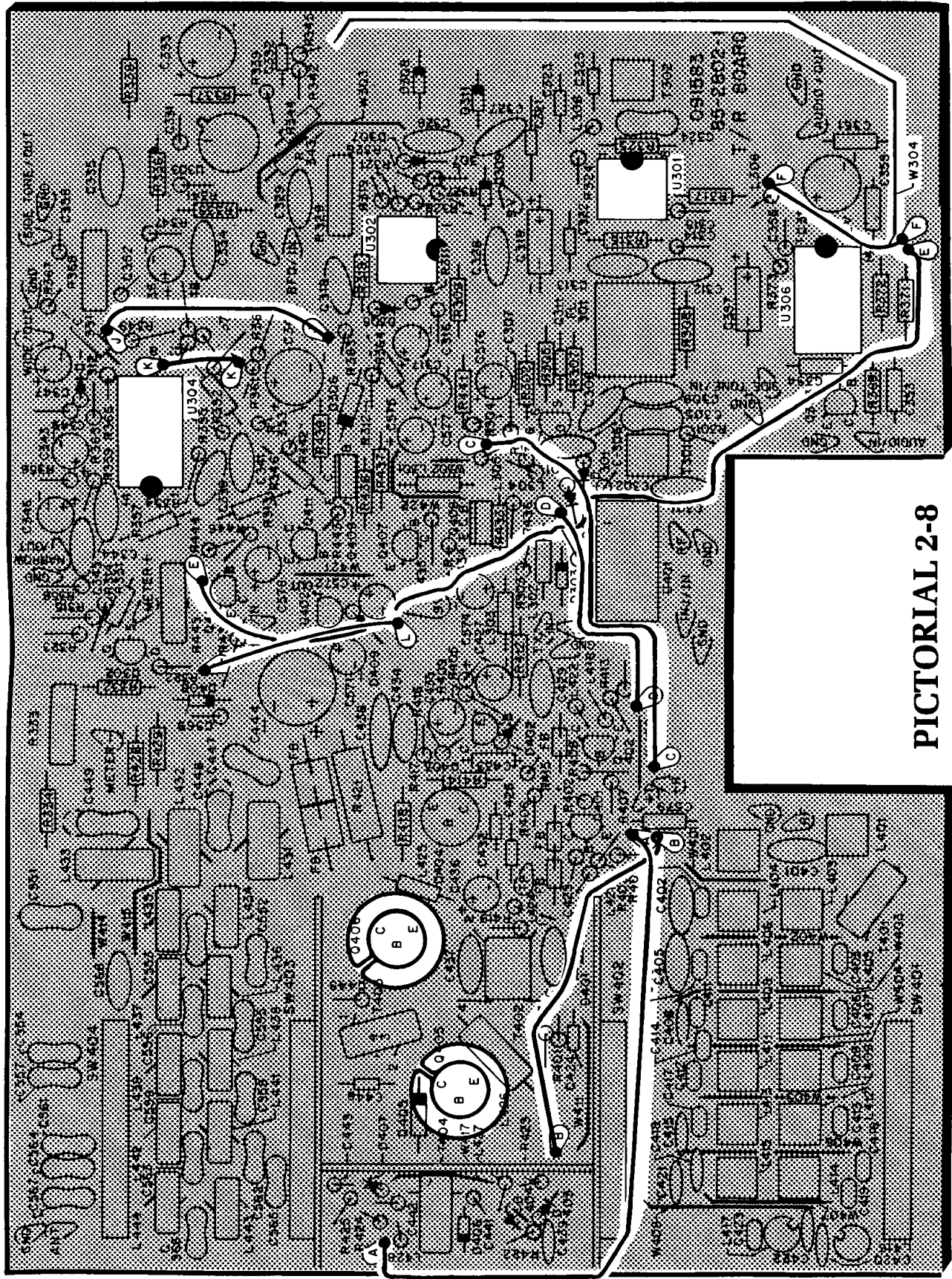

PICTORIAL 2-8

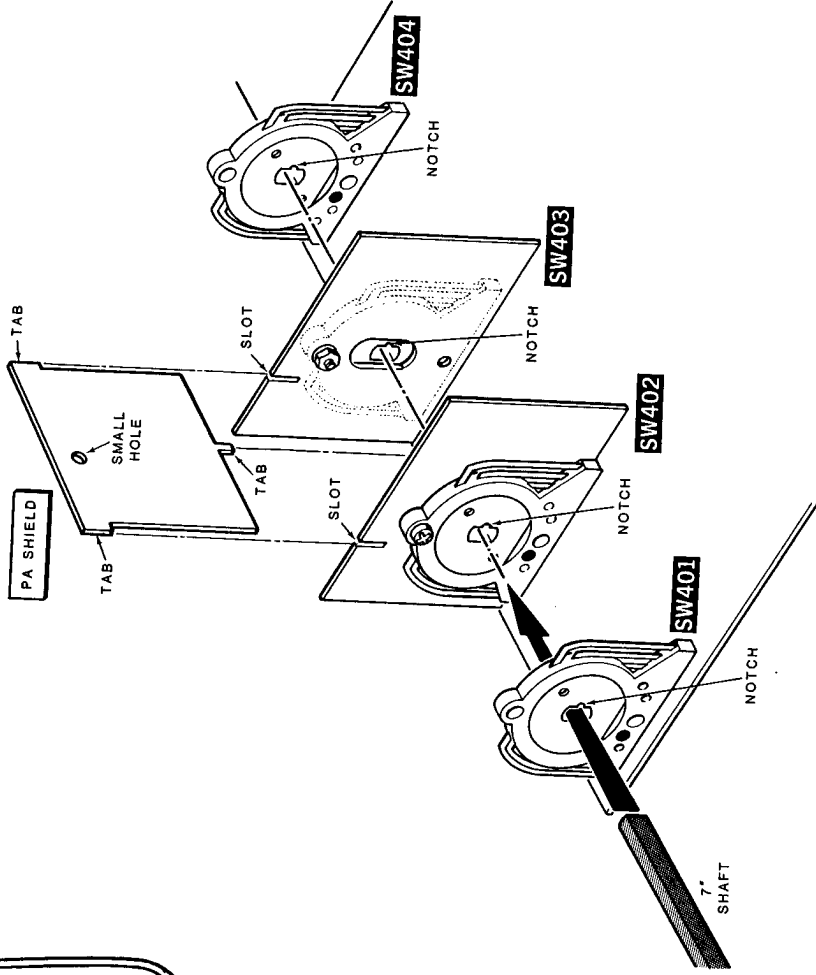
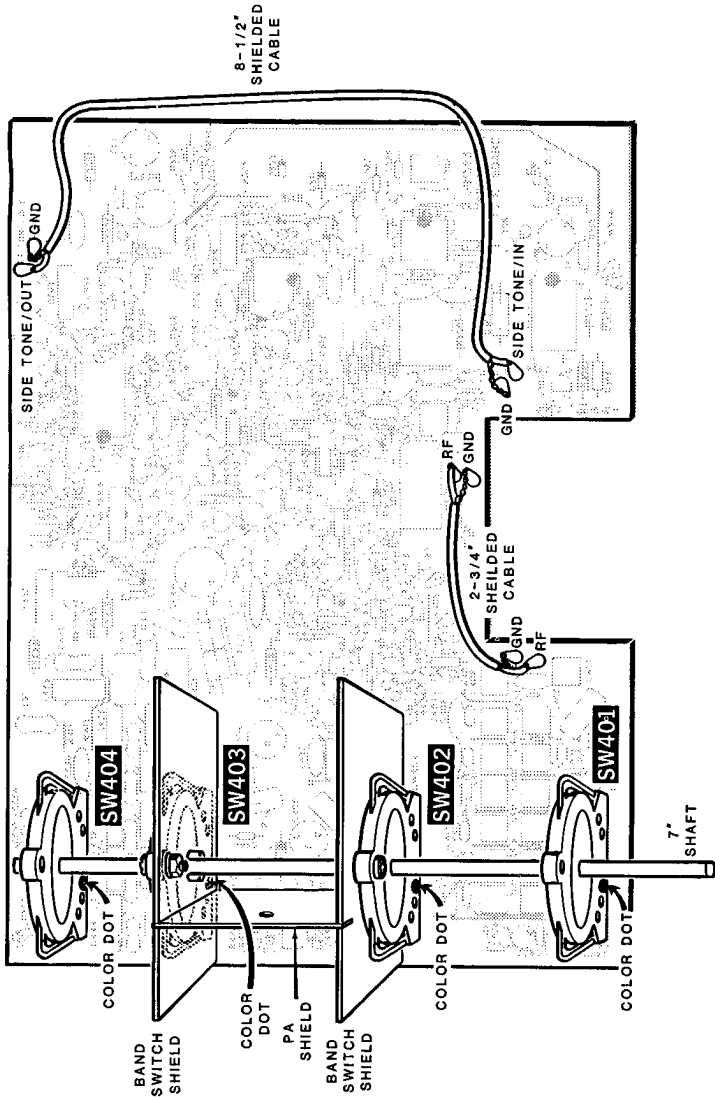

PICTORIAL 2-9

Detail 2-9E

Chassis Parts Pictorial

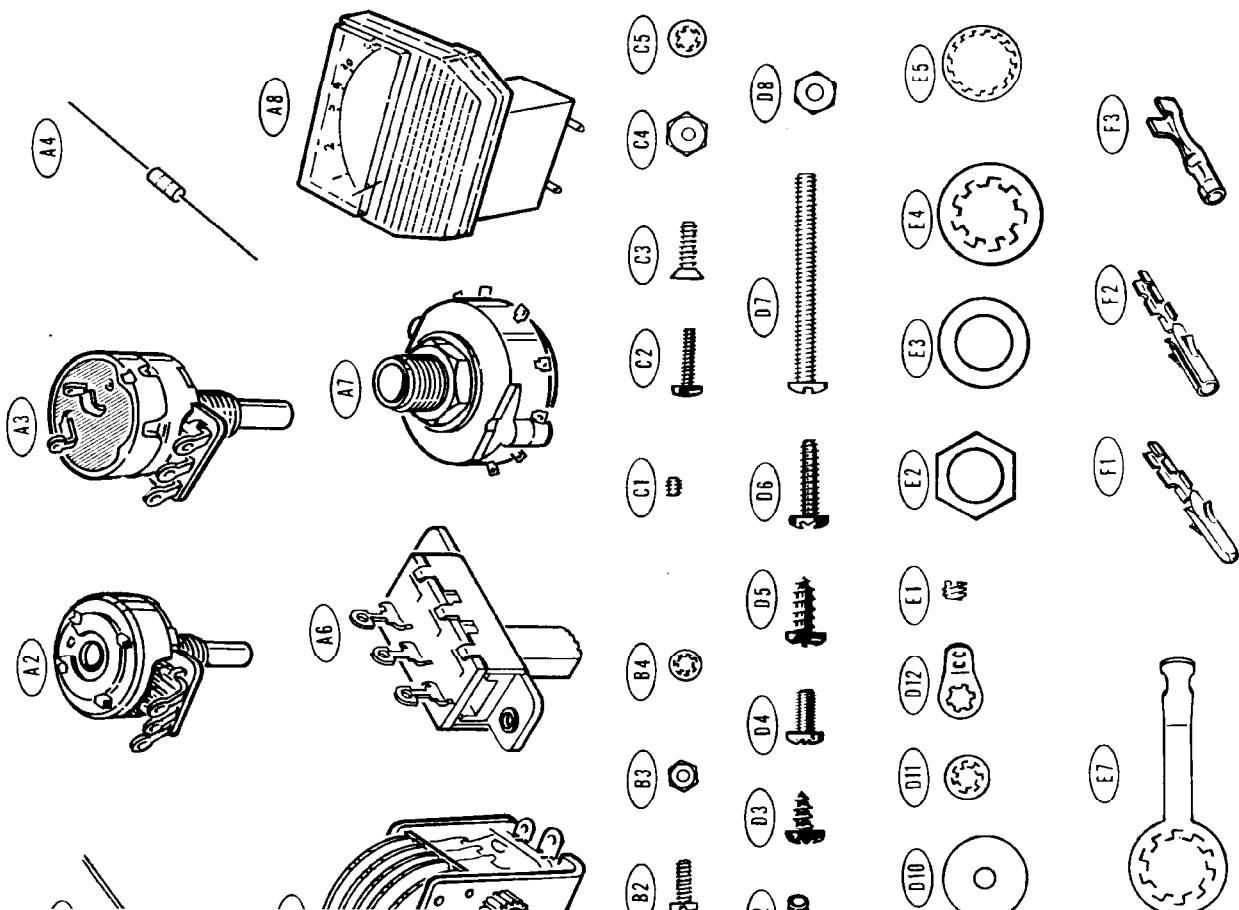
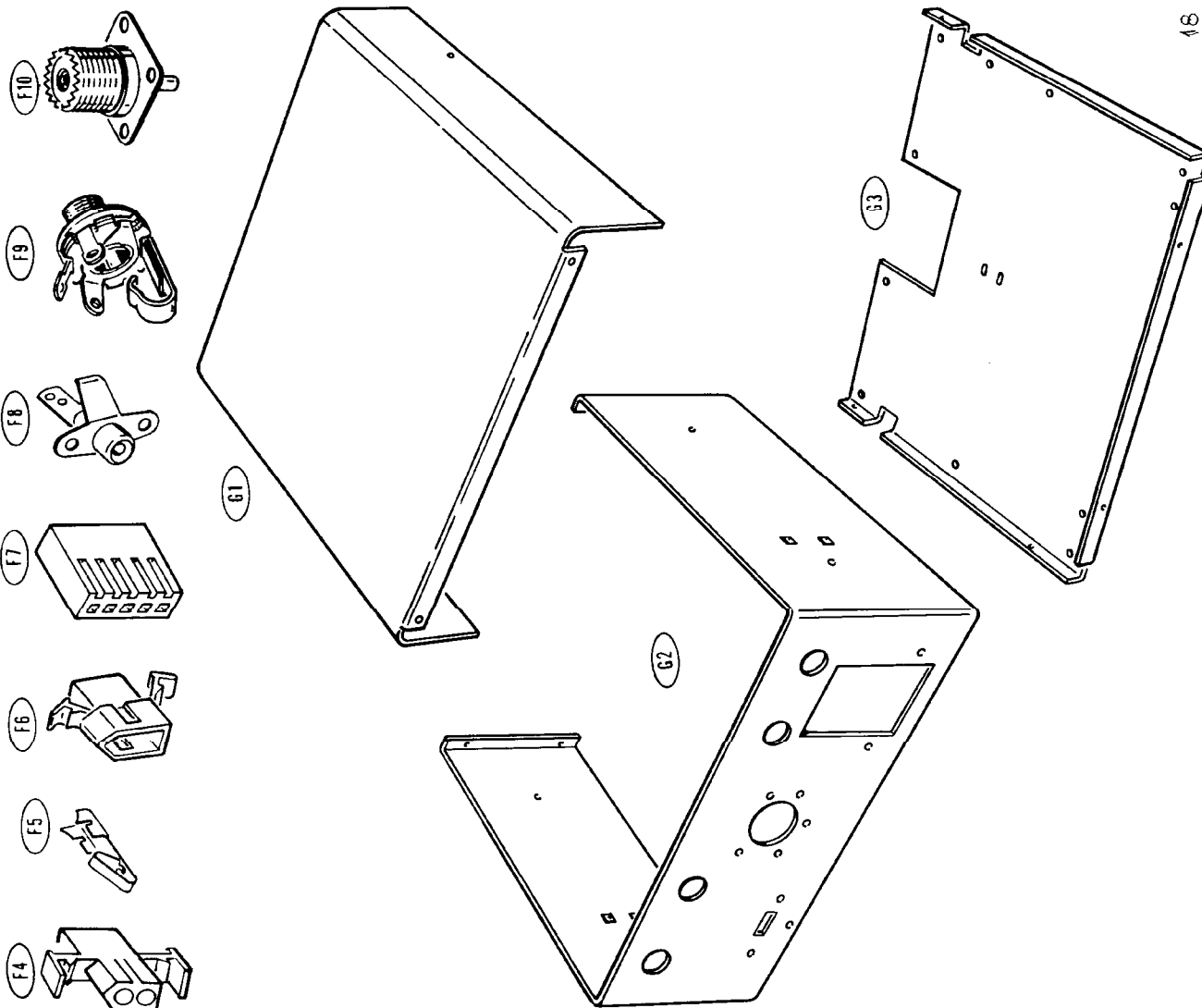

Chassis Parts Pictorial (Cont'd)

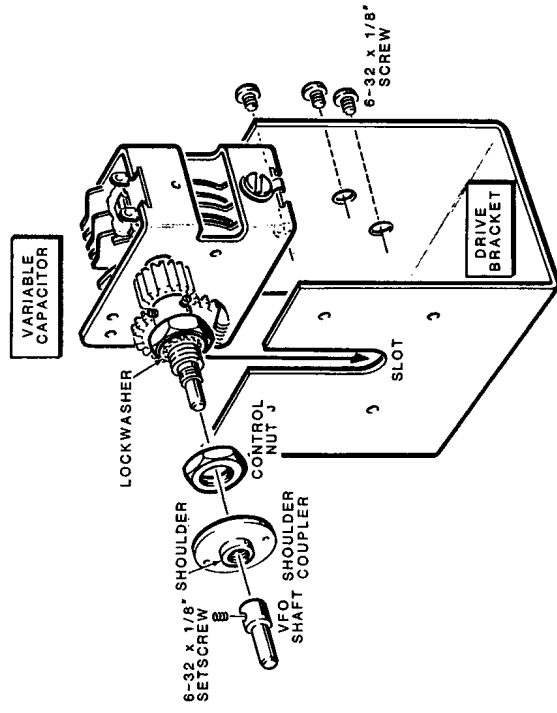
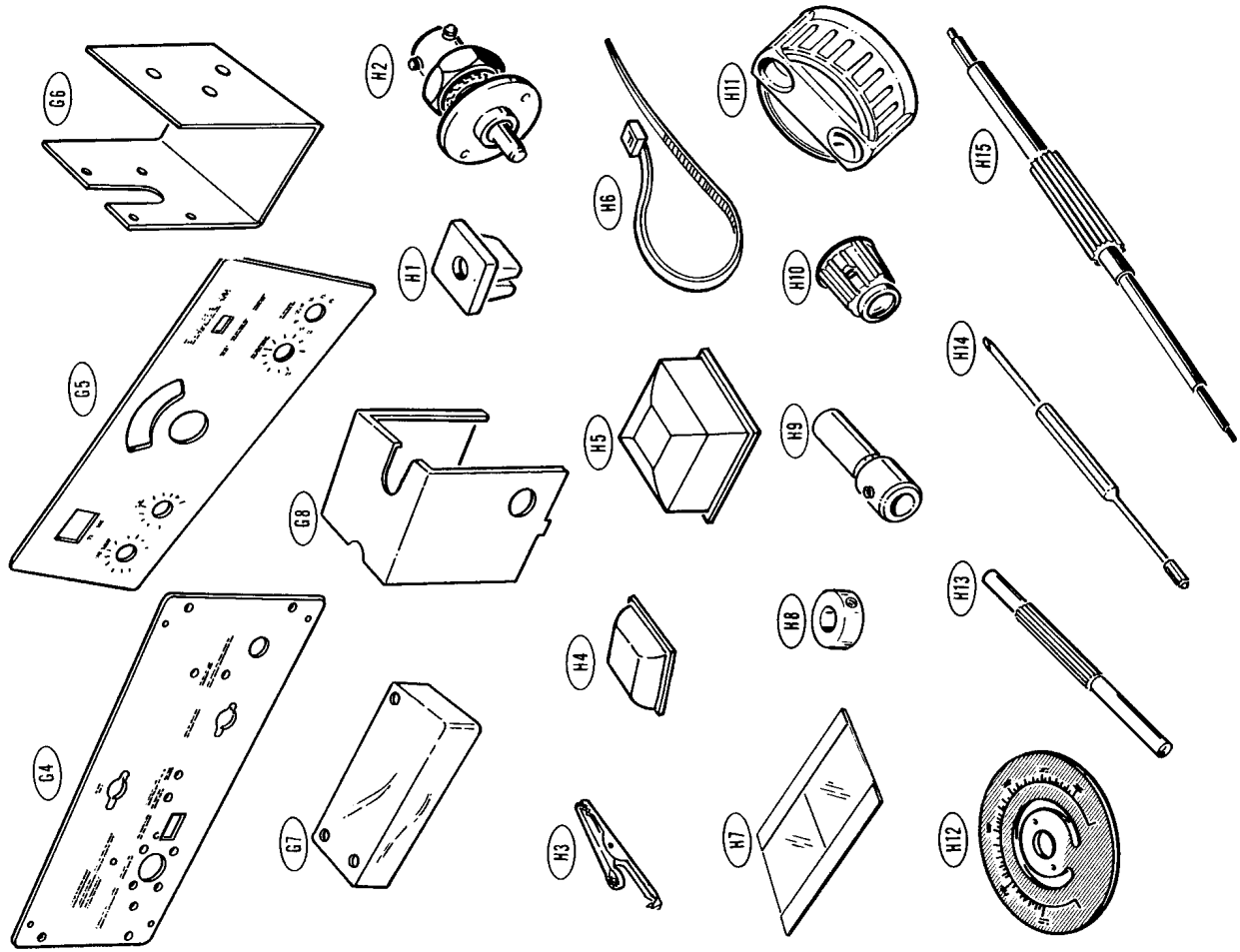

PICTORIAL 3-1

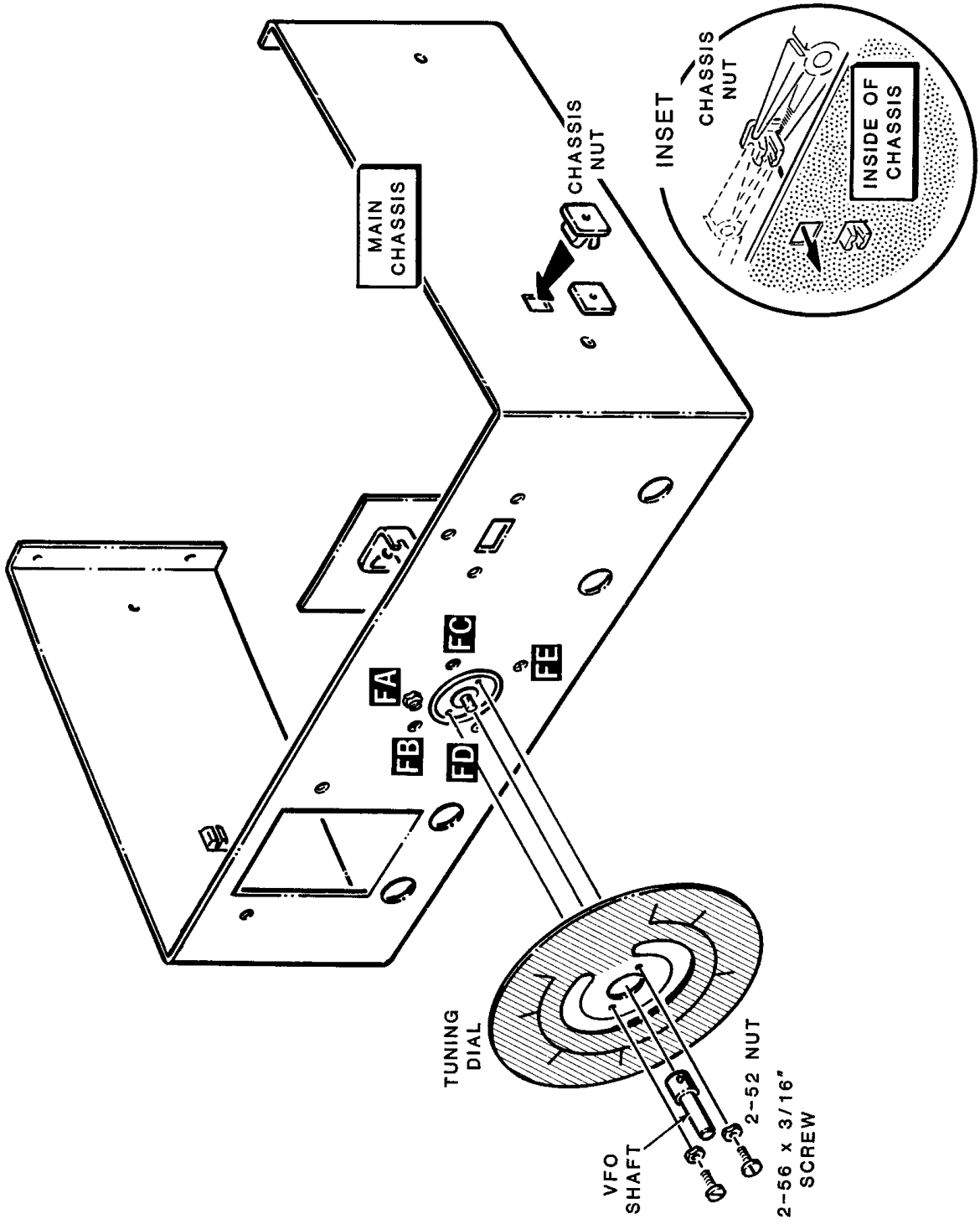

PICTORIAL 3-2

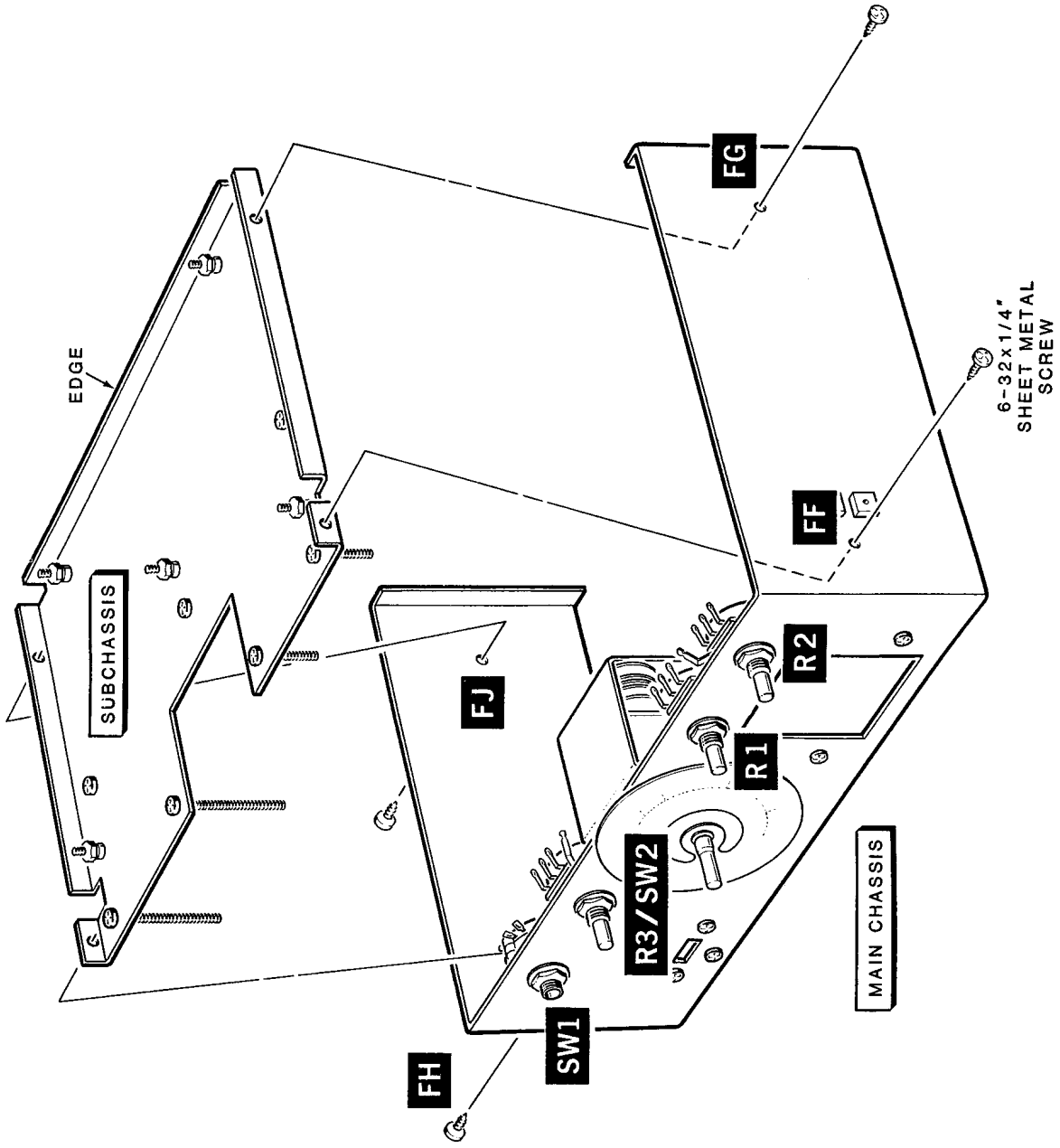

PICTORIAL 3-5

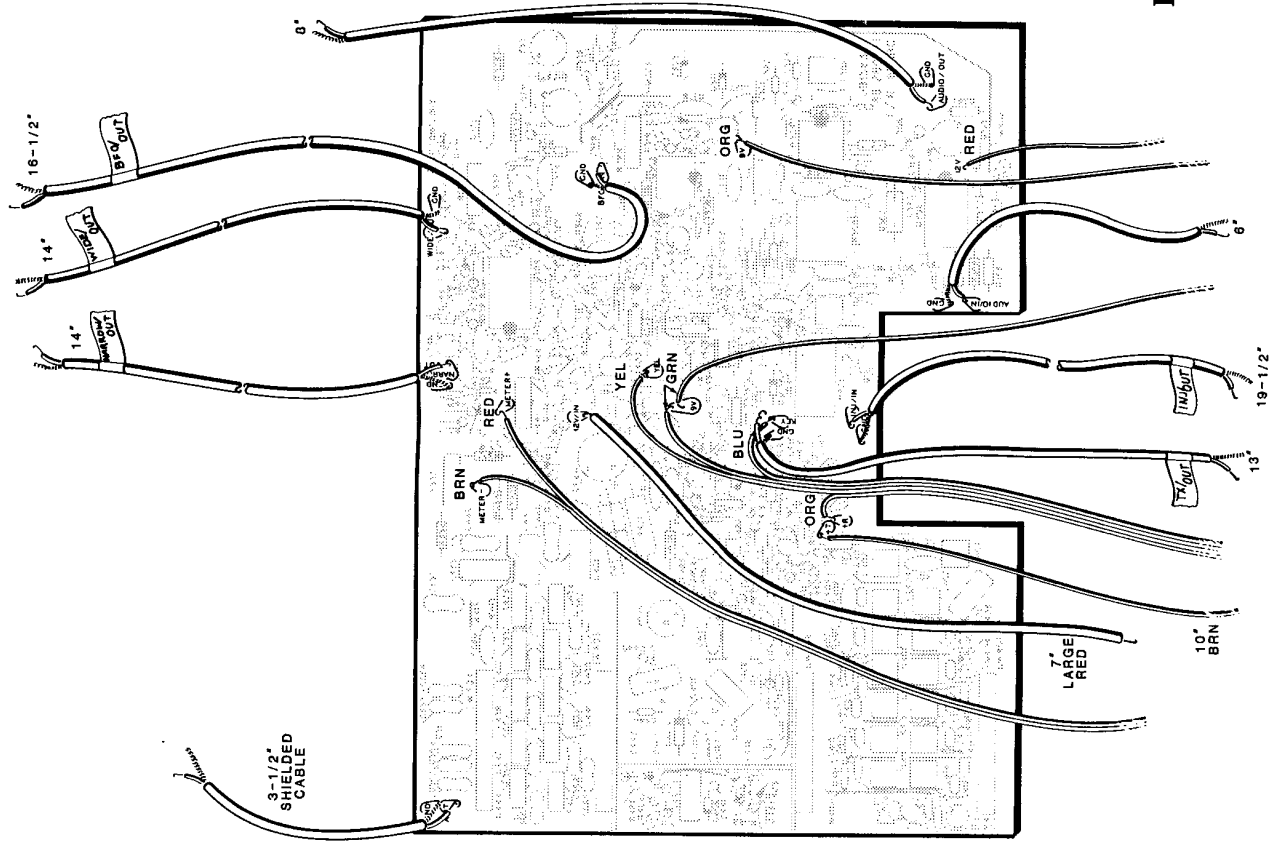

PICTORIAL 3-6

PART A

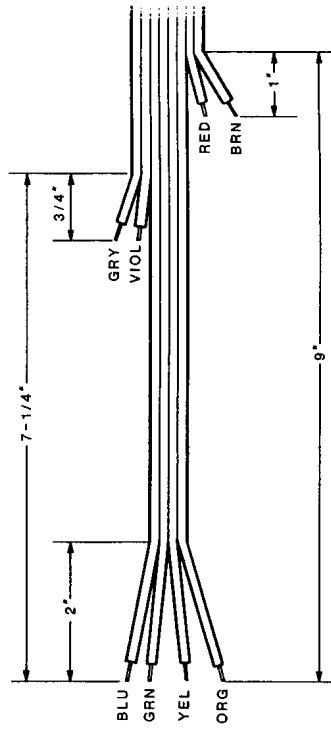

END A

PART B

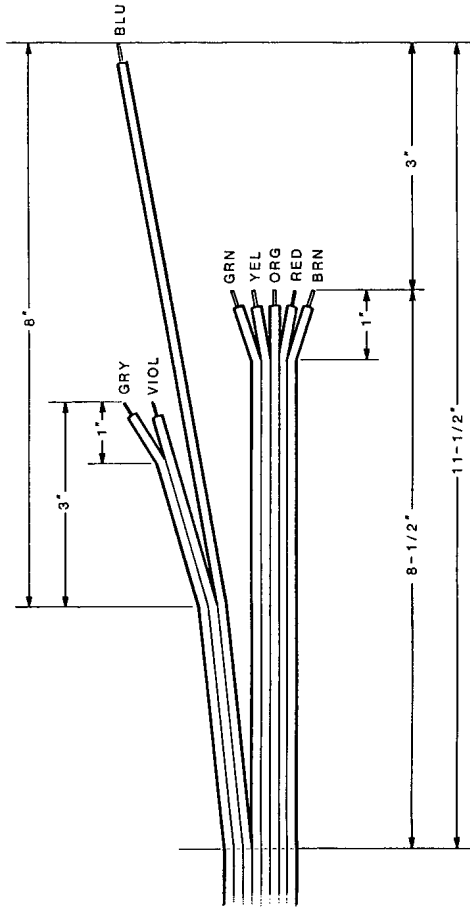

END B

Detail 3-6A

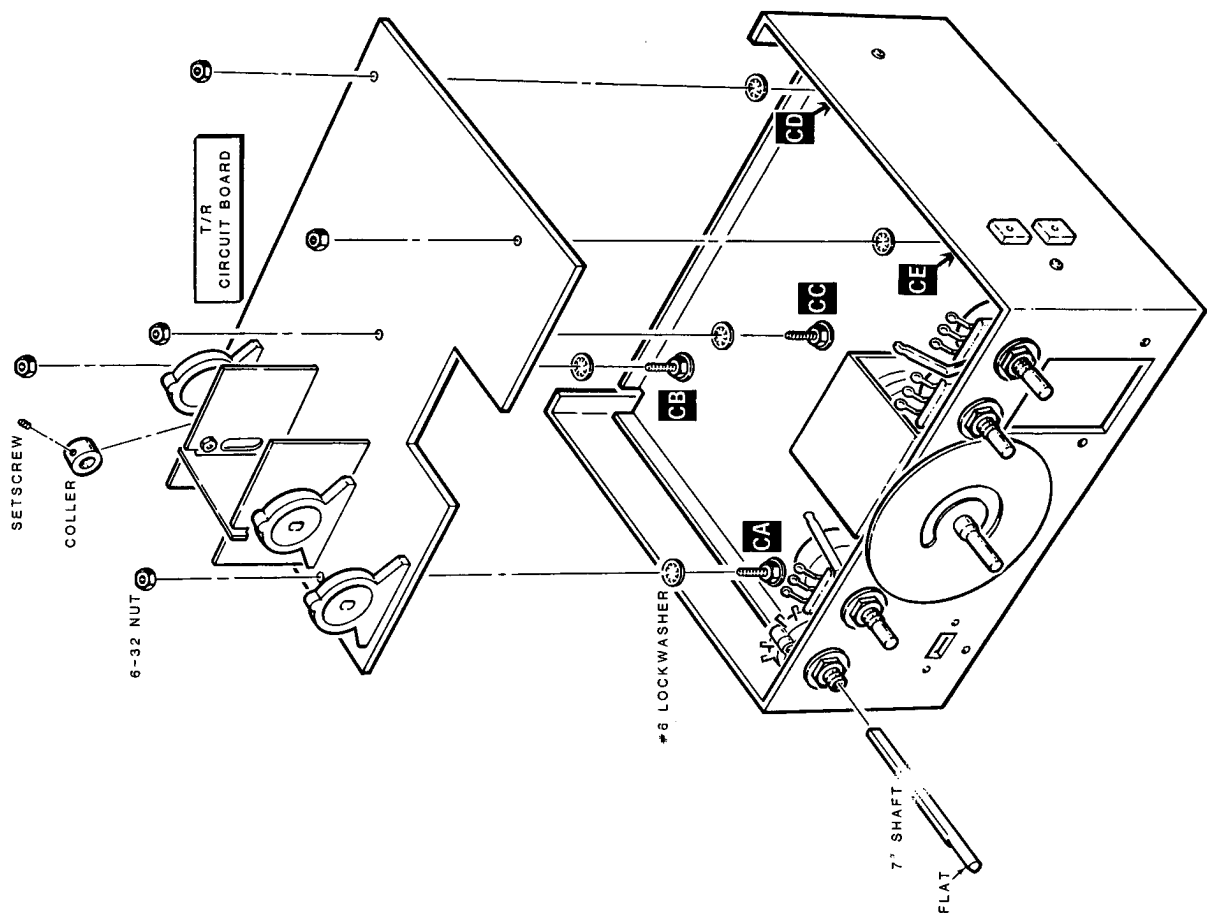

Detail 3-7A

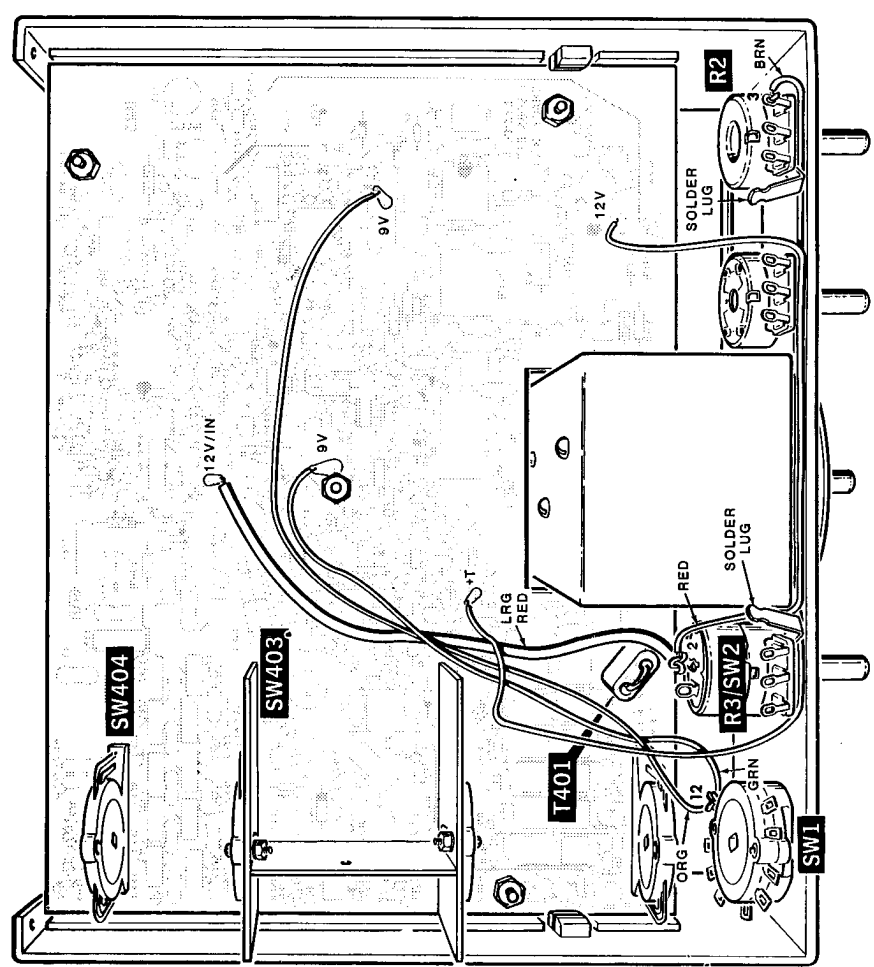

PICTORIAL 3-7

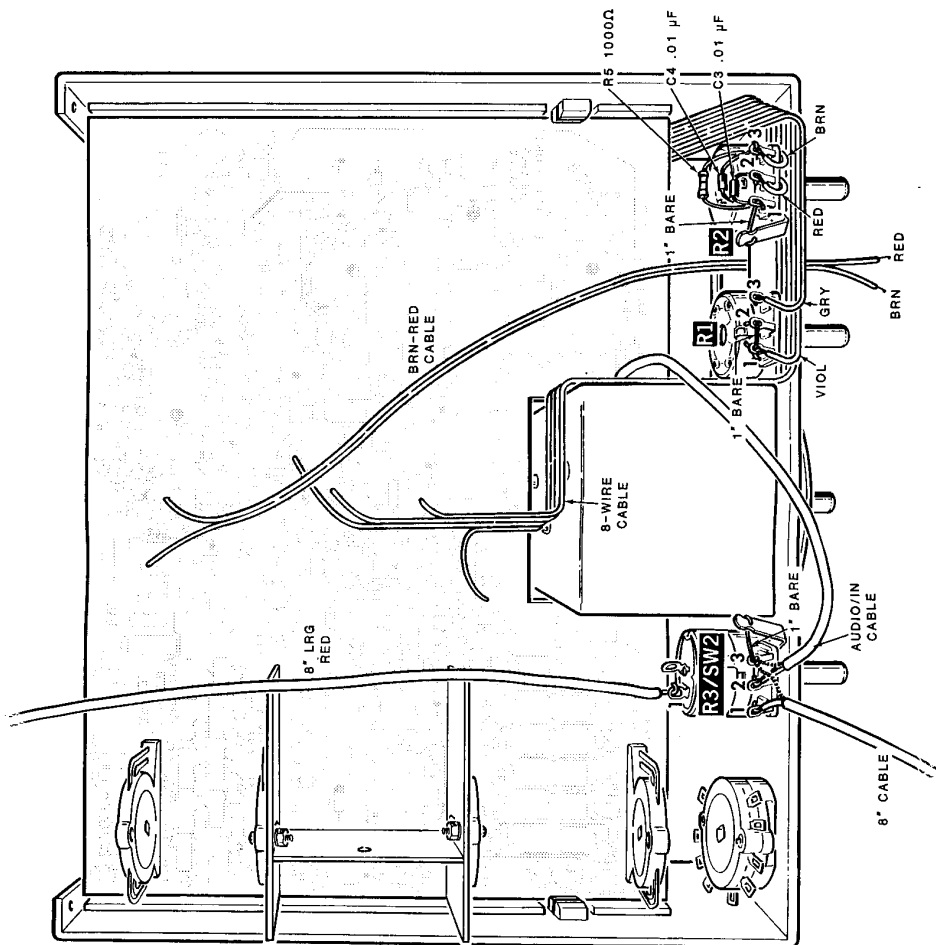

PICTORIAL 3-8

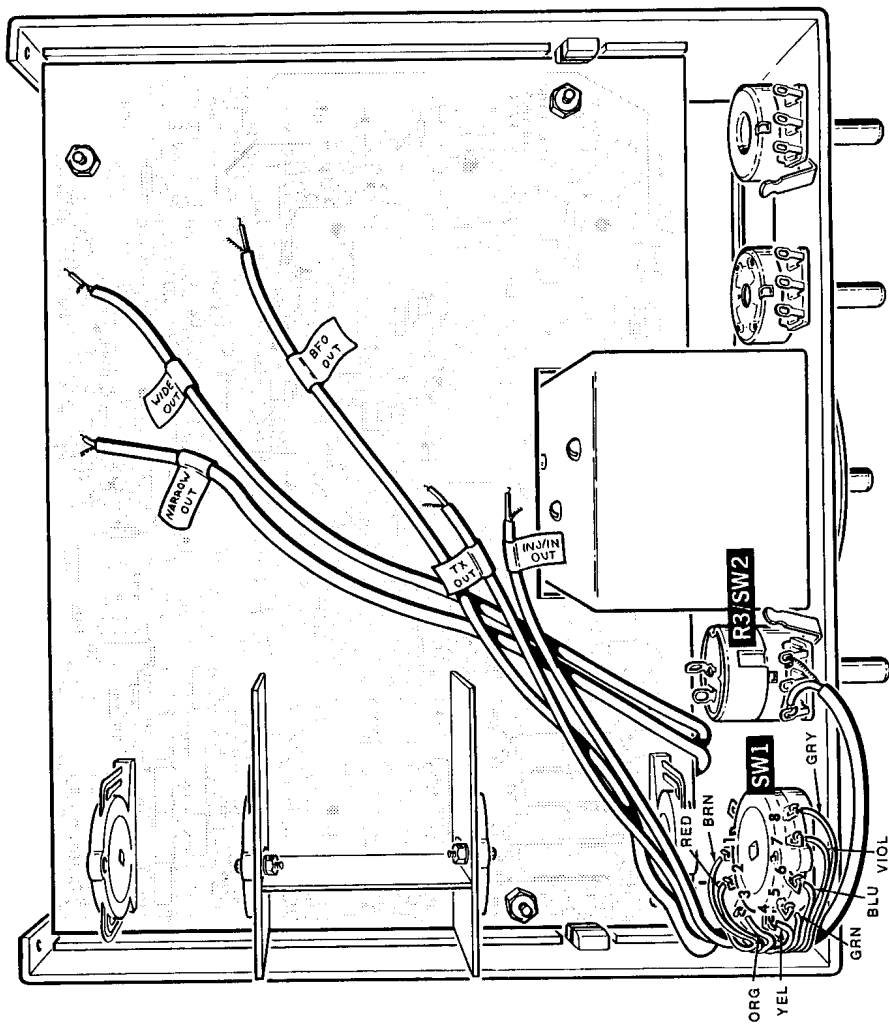

PICTORIAL 3-9

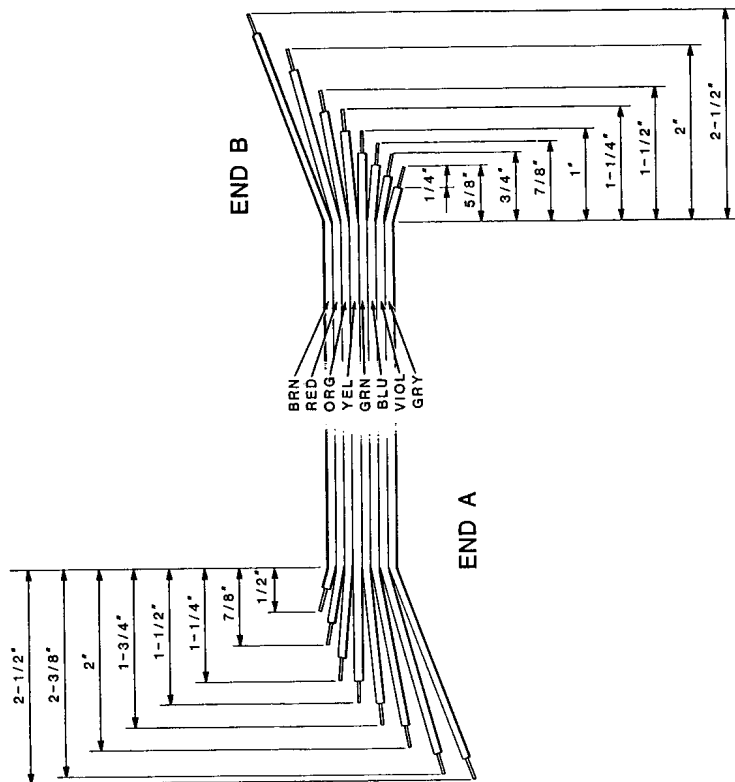

Detail 3-9A

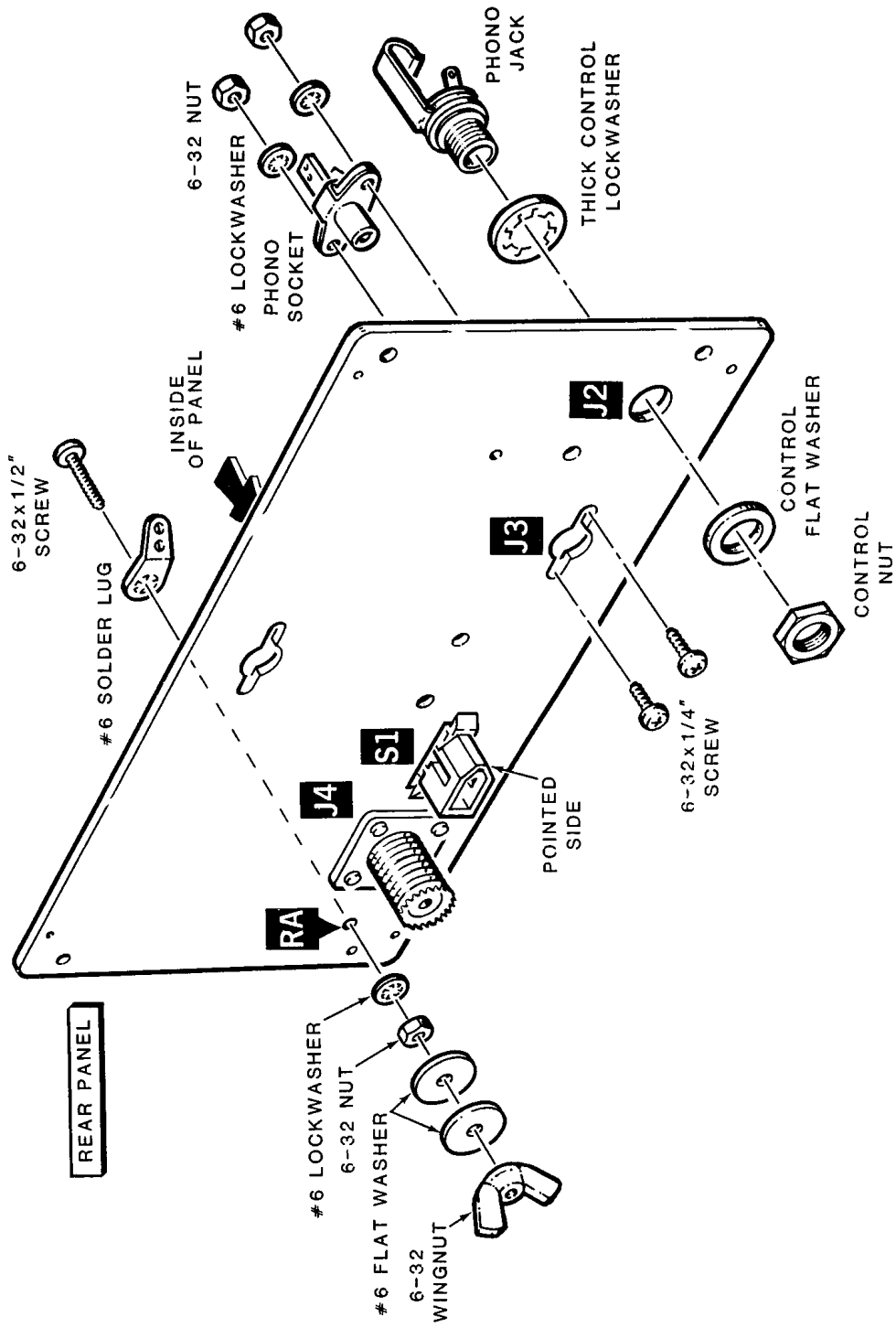

PICTORIAL 3-10

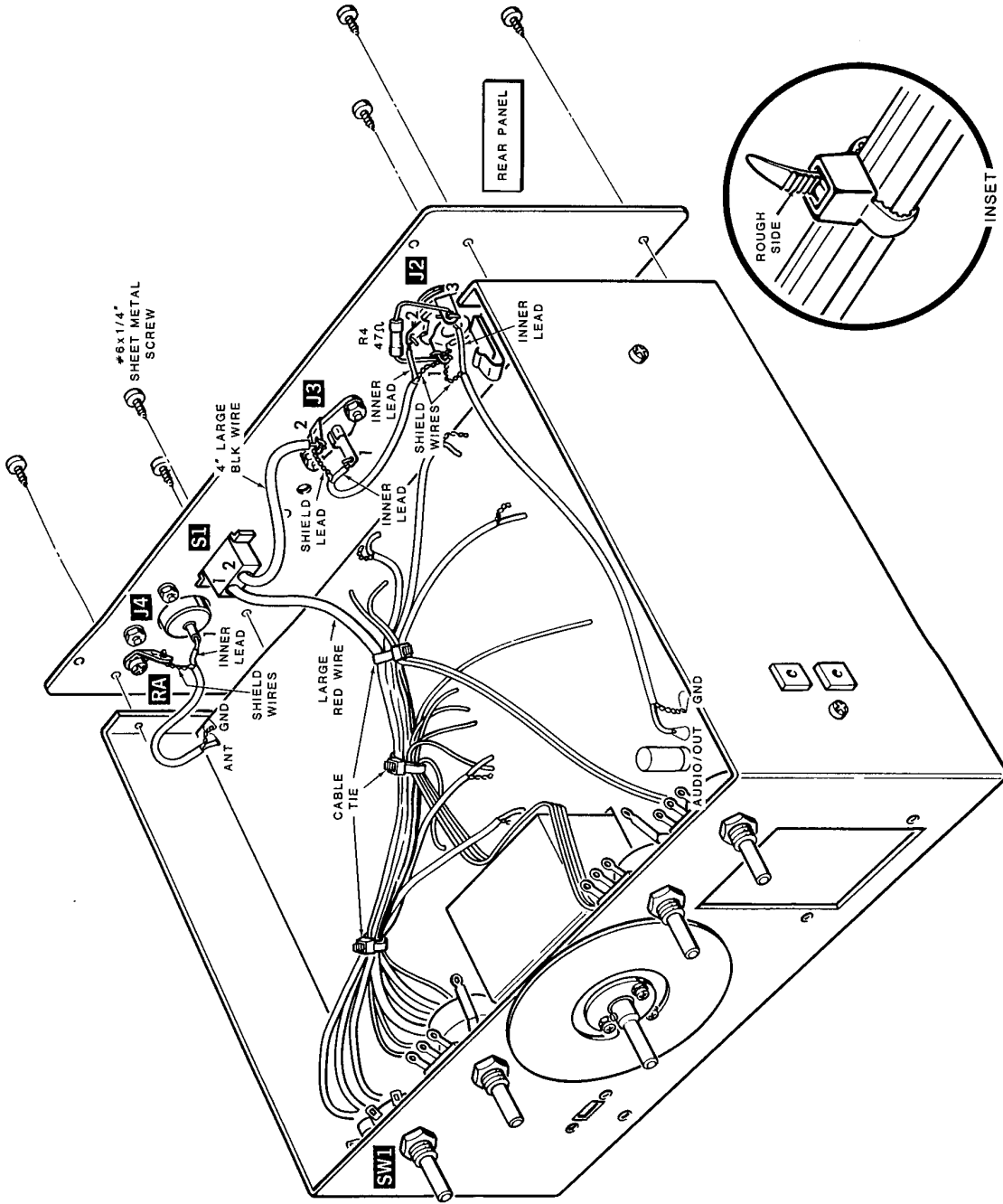

PICTORIAL 3-11

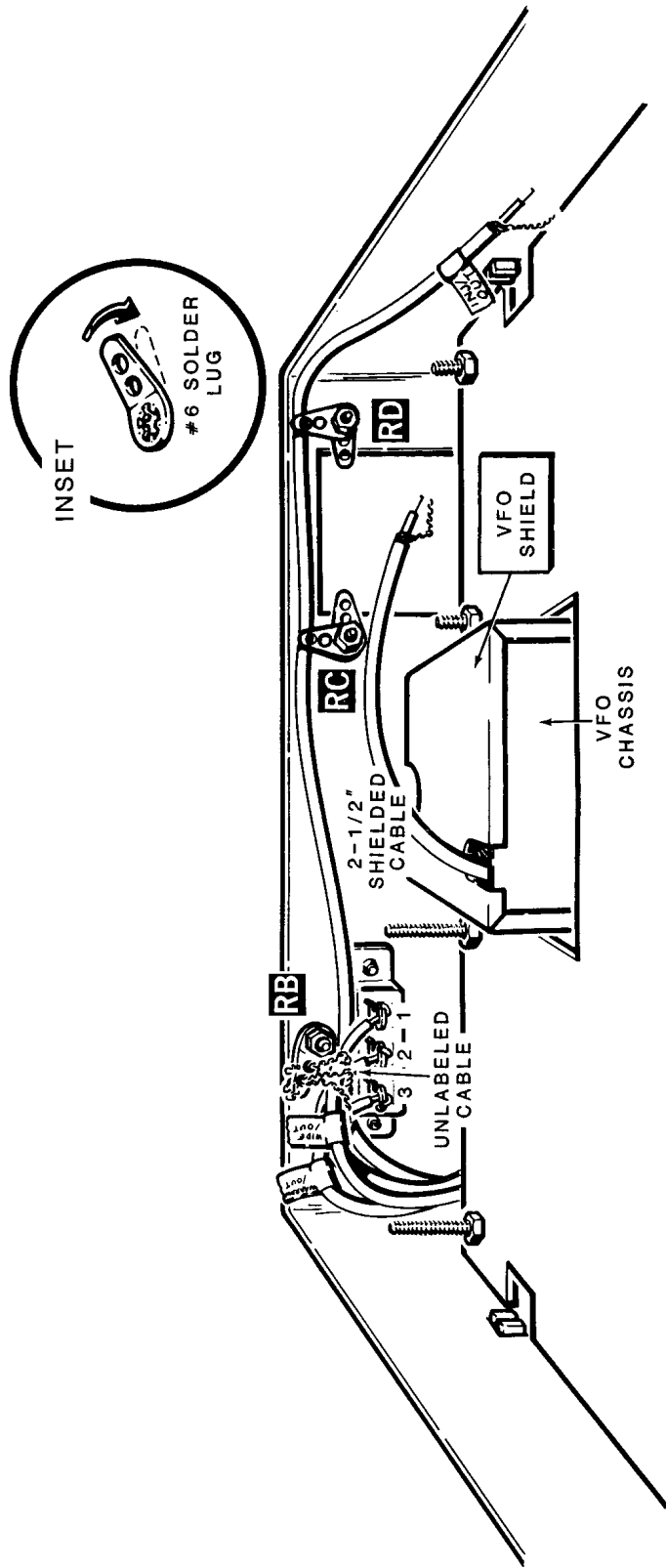

PICTORIAL 3-12

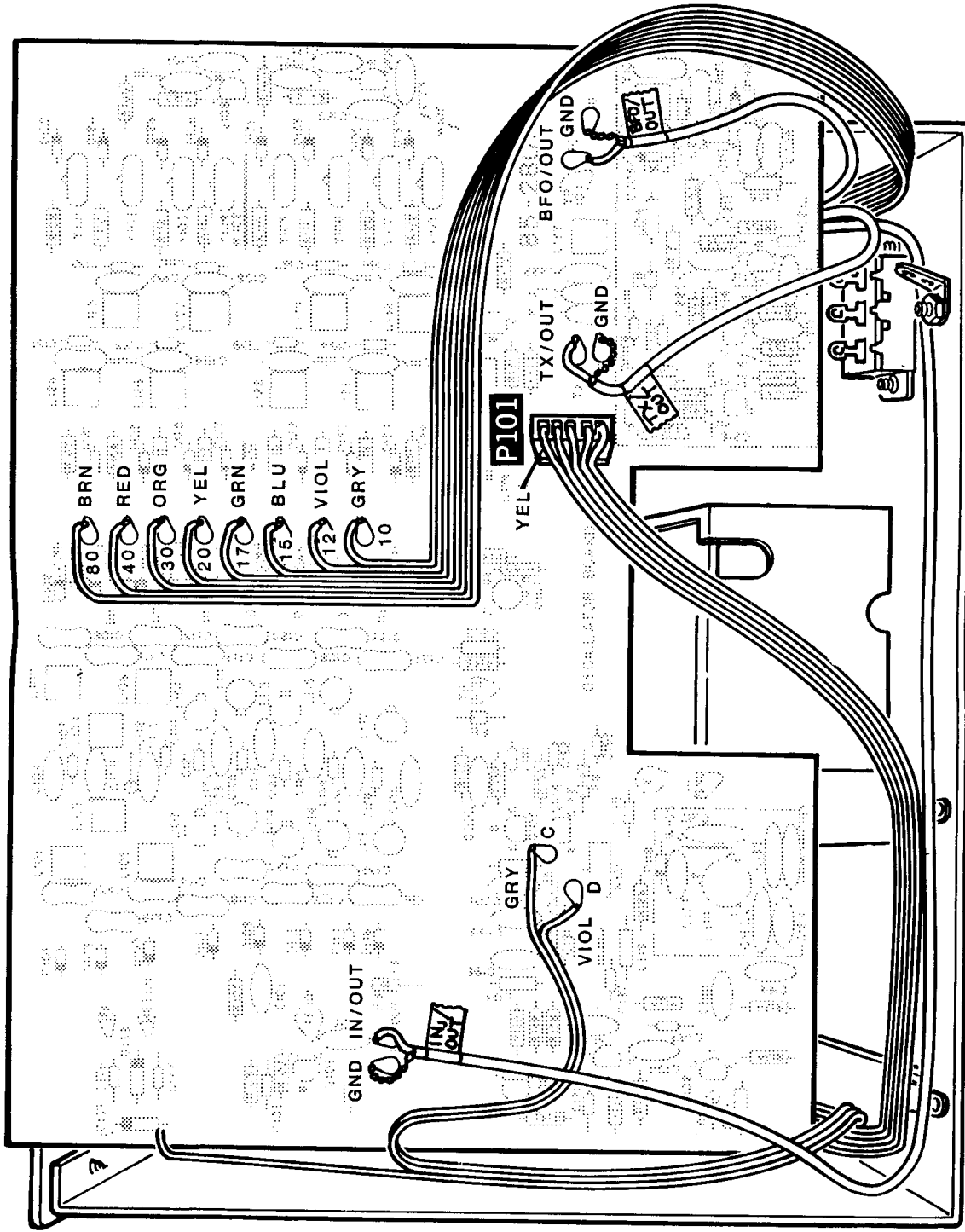

PICTORIAL 3-13

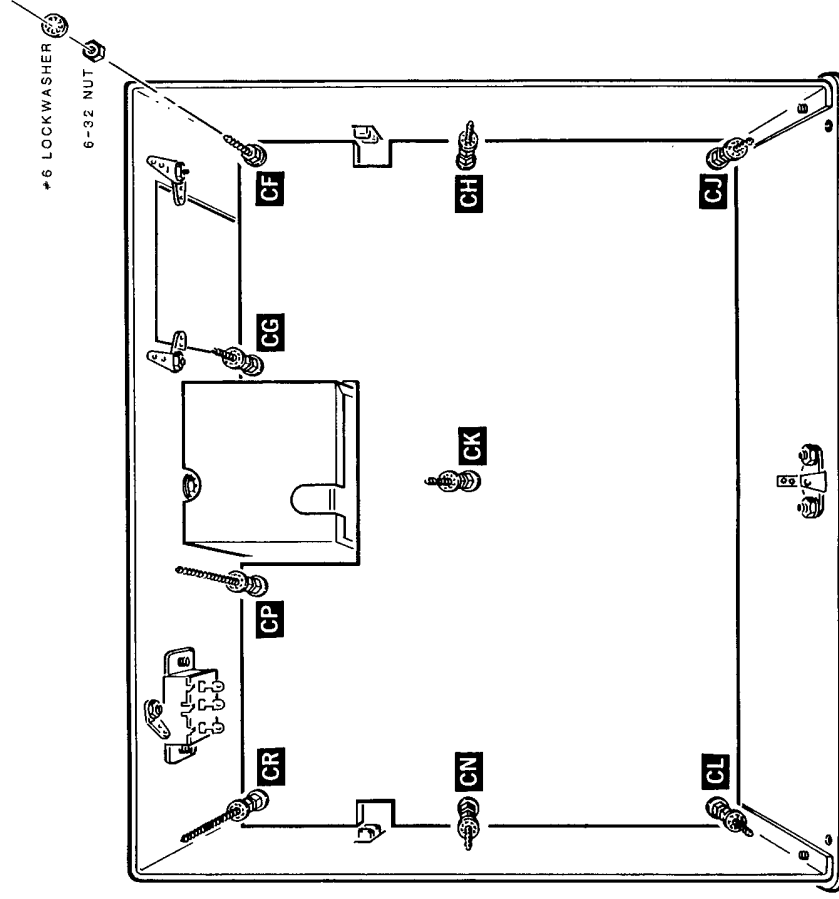
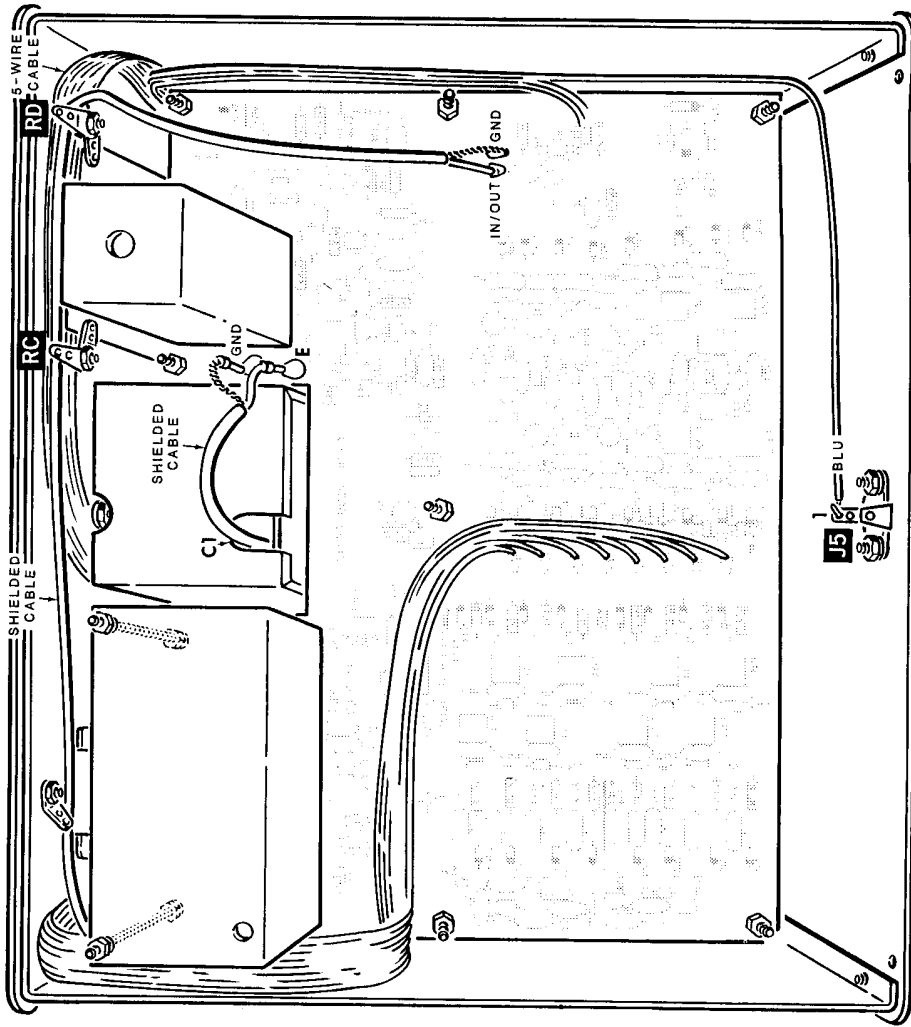

Detail 3-14A

PICTORIAL 3-14

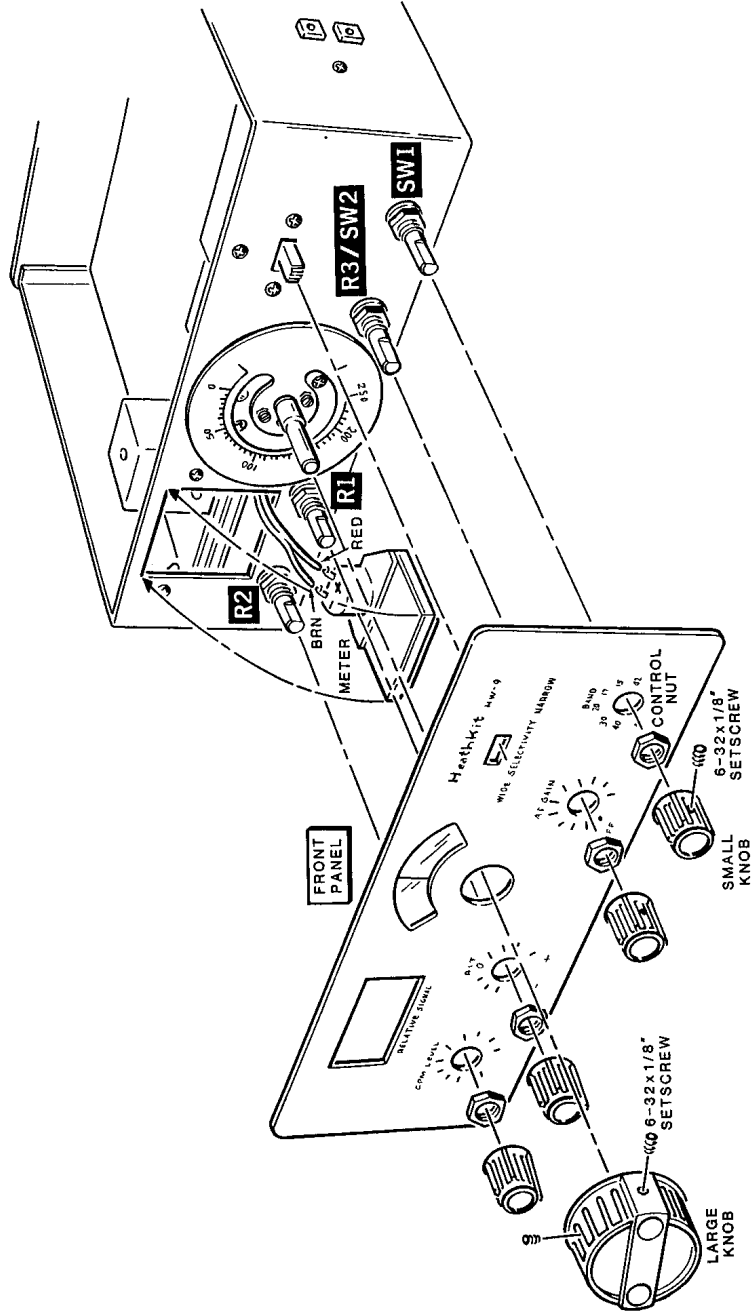

PICTORIAL 3-15

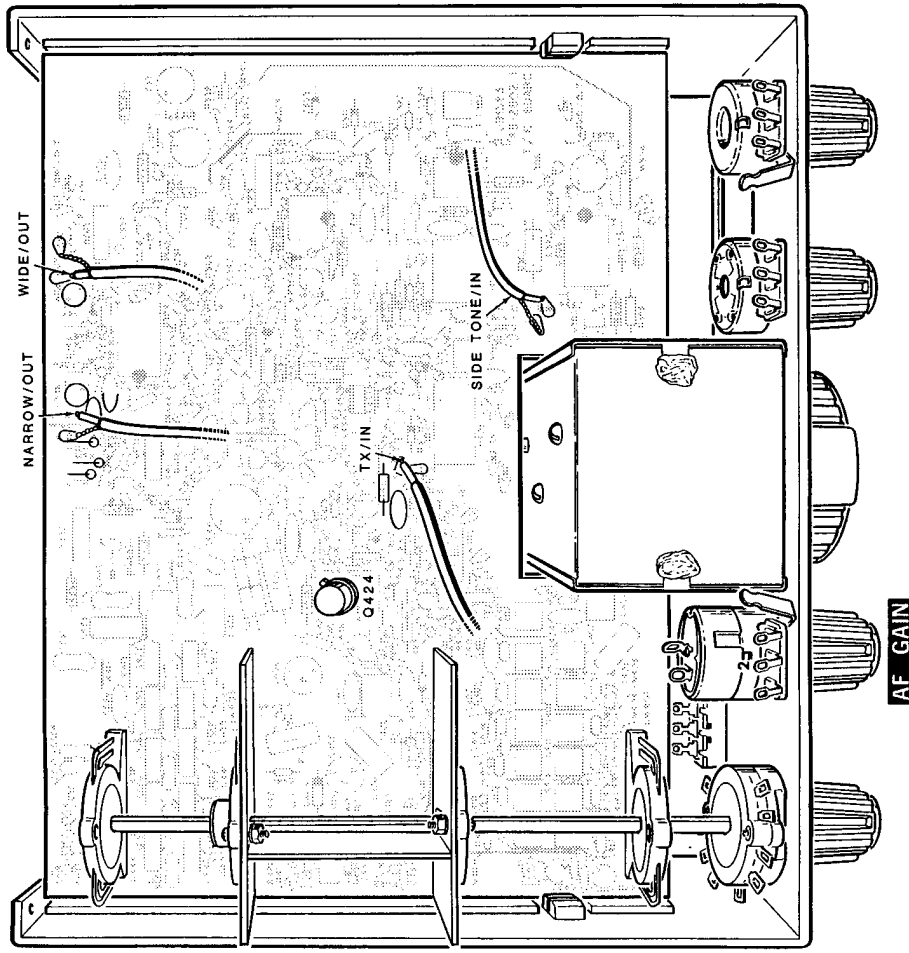

PICTORIAL 4-2

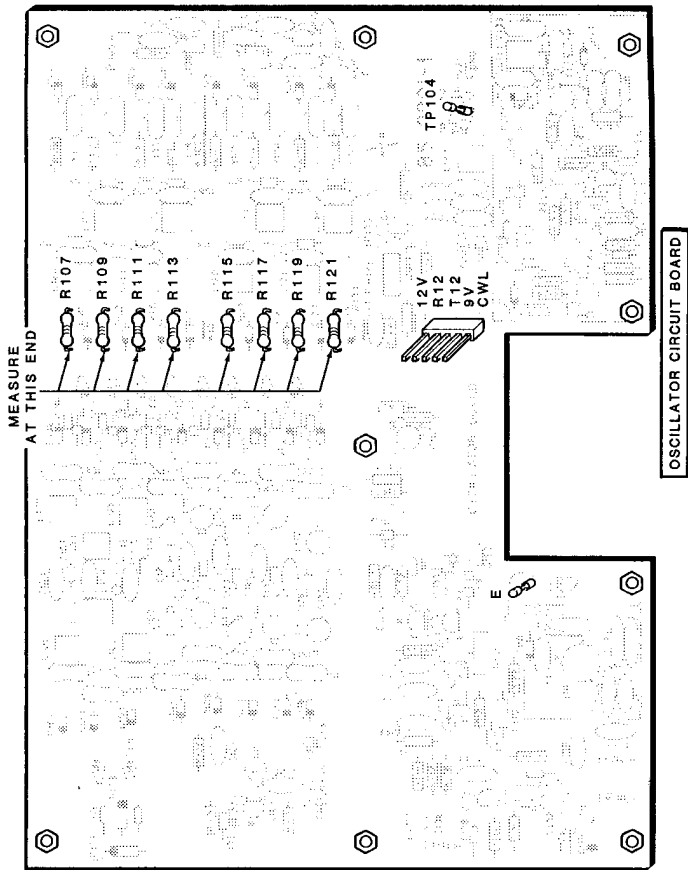

PICTORIAL 4-1

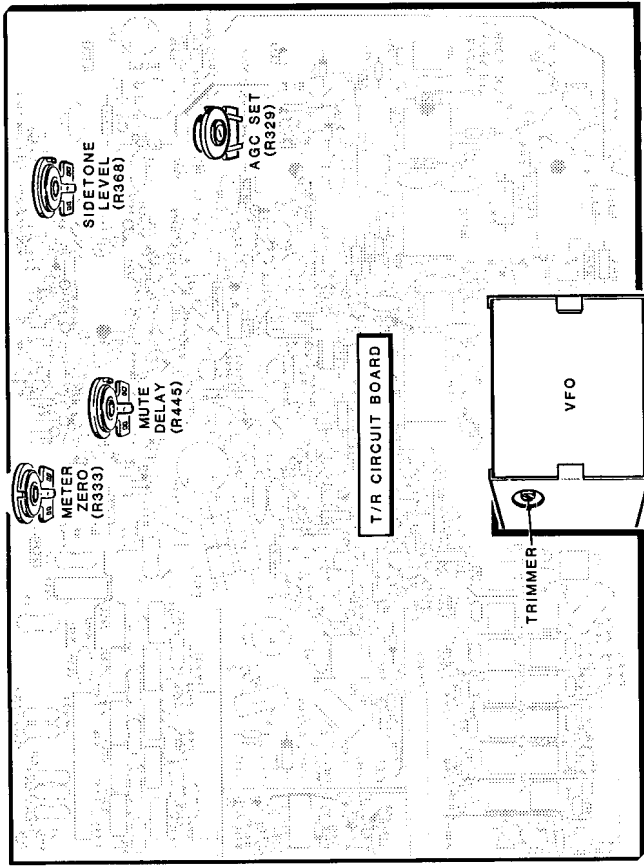

PICTORIAL 5-2

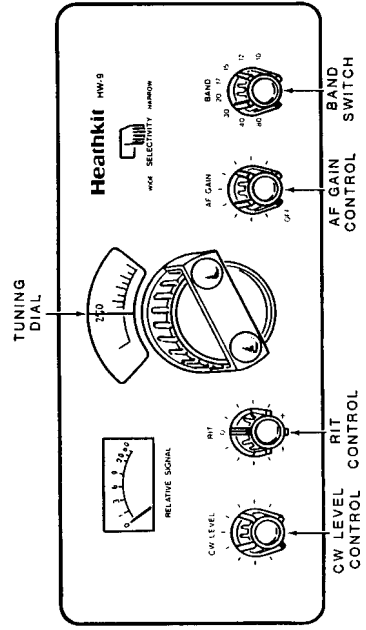

PICTORIAL 5-1

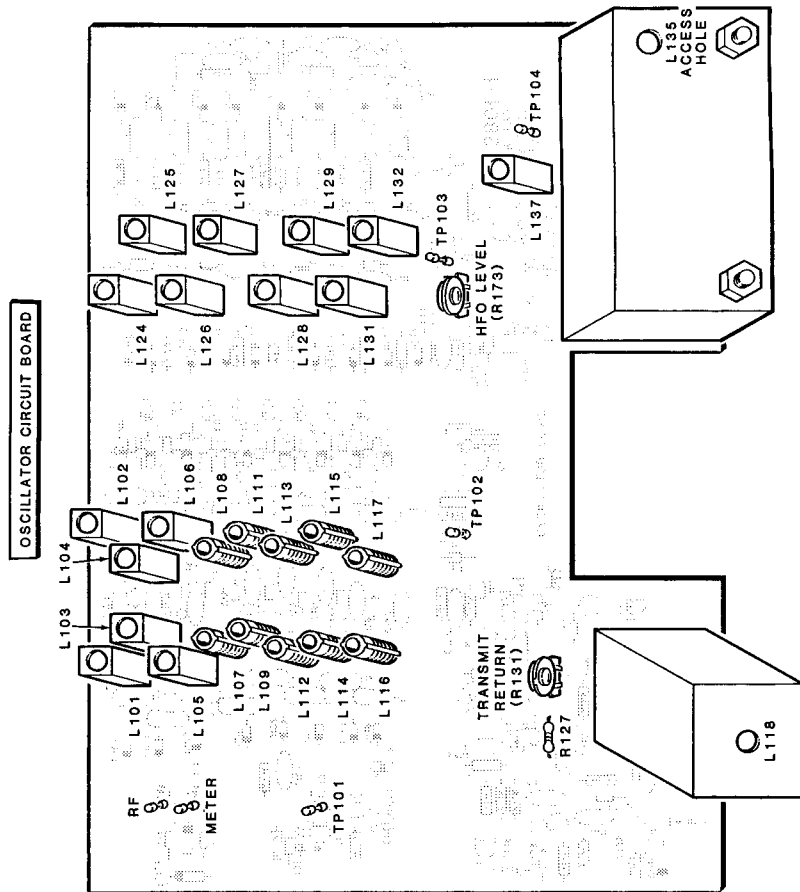

PICTORIAL 5-3

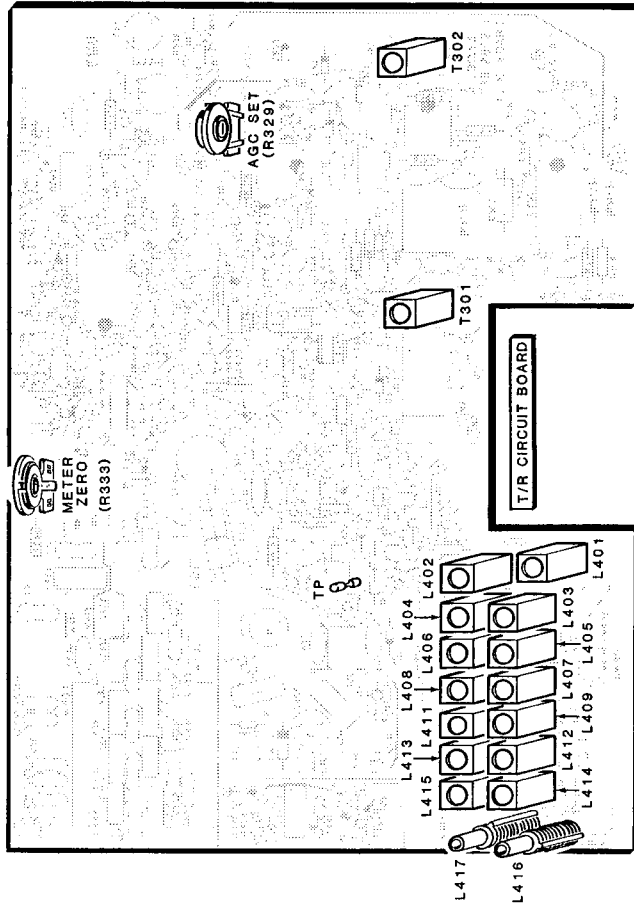

PICTORIAL 5-4

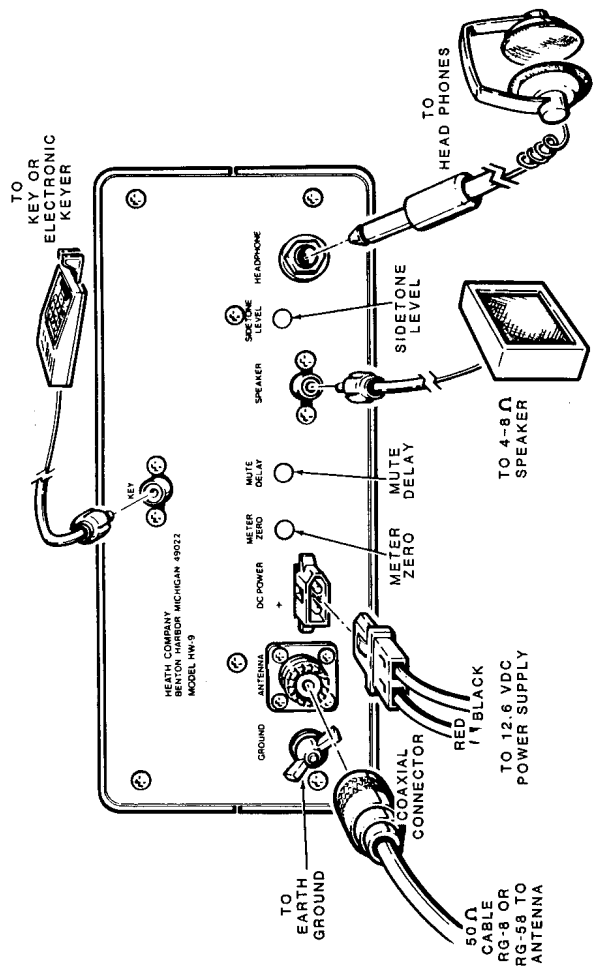

PICTORIAL 7-1

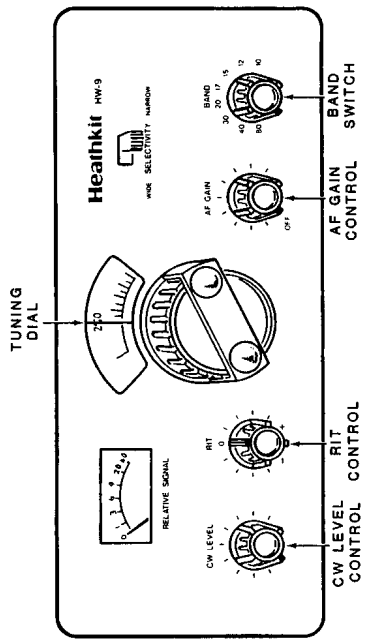

PICTORIAL 7-2

NOTE: To find the PART NUMBER of a component for the purpose of ordering a replacement part:

A. Find the circuit component number (R5, C3, etc.) on the X-Ray View.

B. Locate this same number in the "Circuit Component Number" column of the corresponding "Parts List."

C. Adjacent to the circuit component number, you will find the PART NUMBER and DESCRIPTION which must be supplied when you order a replacement part.

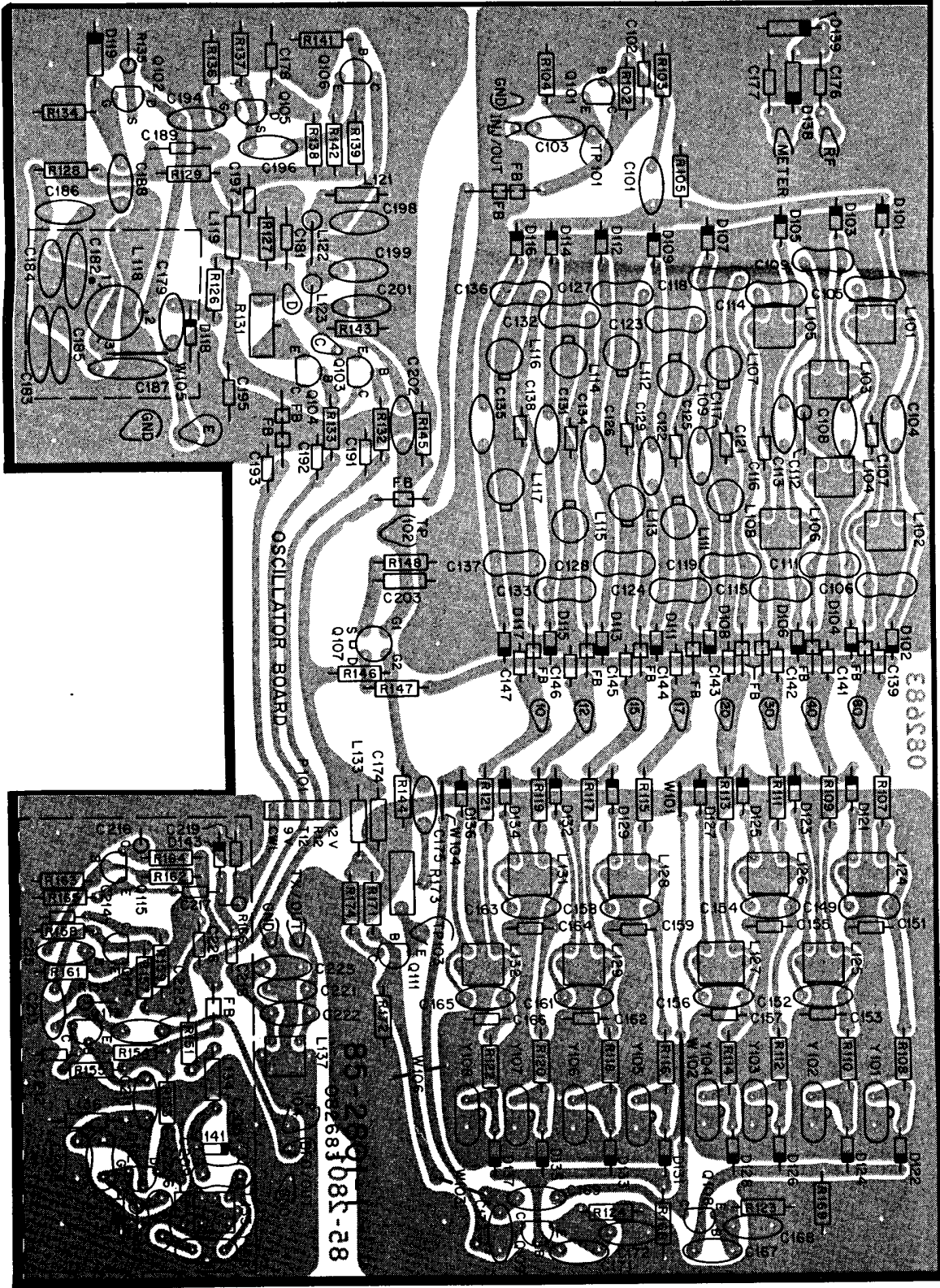

Oscillator Circuit Board
(Shown from the component side.)

CIRCUIT BOARD X-RAY VIEWS

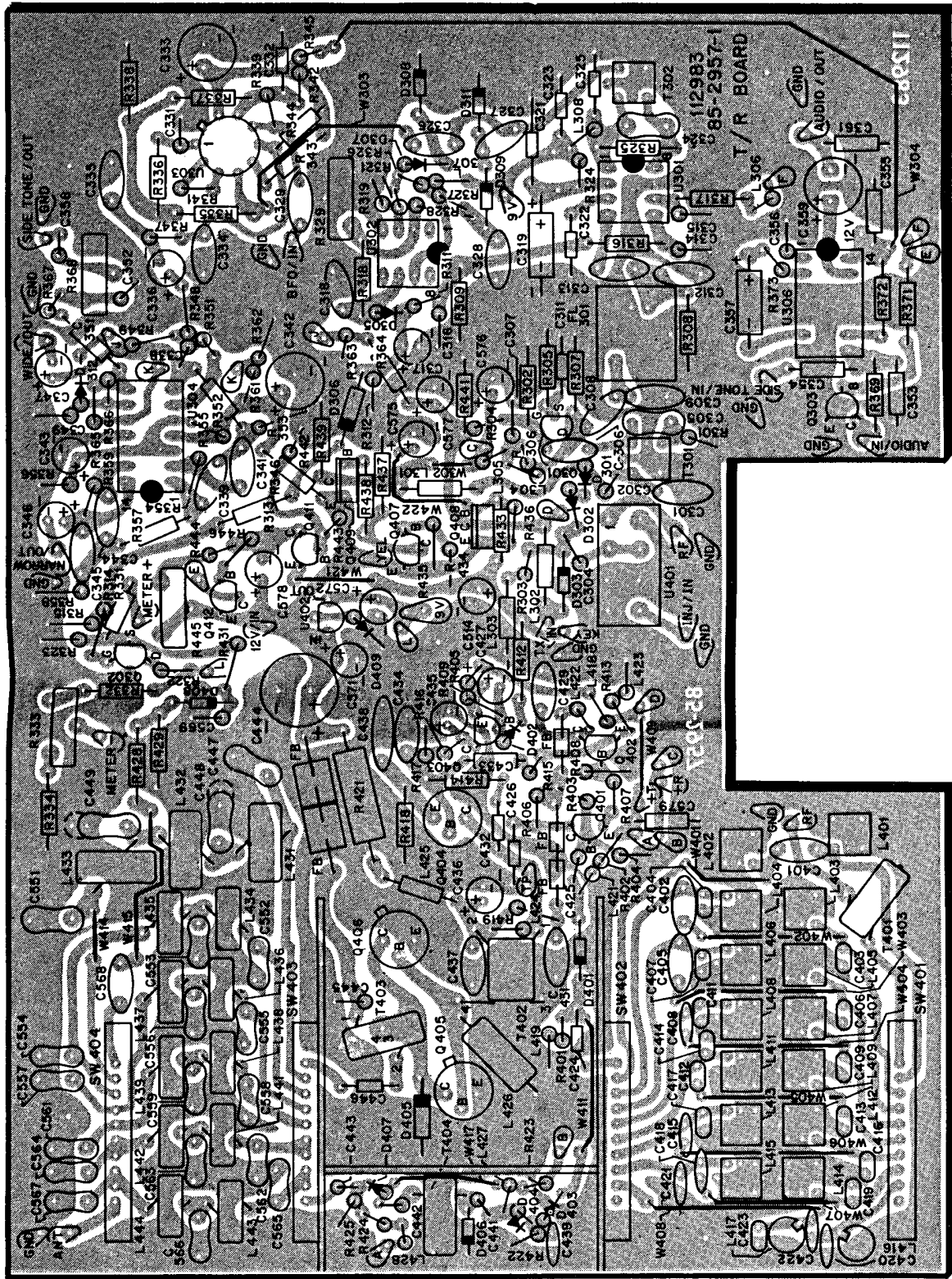

T/R Circuit Board

(Shown from the component side.)

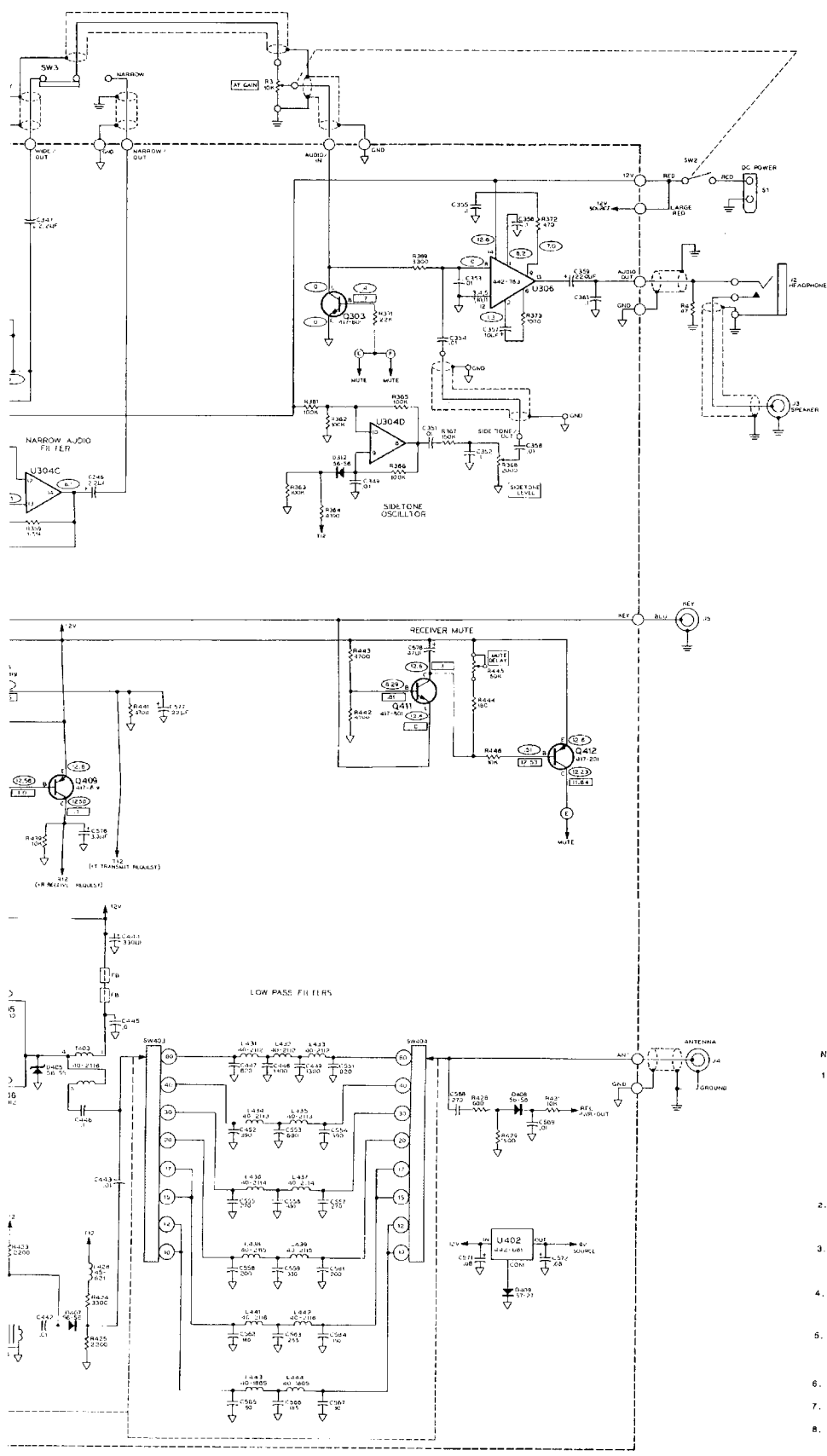

**SCHEMATIC OF THE
HEATHKIT®
DELUXE QRP
CW TRANSCIVER
MODEL HW-9**

NOTES:

1. COMPONENT NUMBERS ARE IN THE FOLLOWING GROUPS:
 1-99 PARTS MOUNTED ON THE CHASSIS.
 100-299 PARTS MOUNTED ON THE OSCILLATOR CIRCUIT BOARD.
 300-399 PARTS MOUNTED IN THE RECEIVER SECTION OF THE T/R CIRCUIT BOARD.
 400-499 PARTS MOUNTED IN THE TRANSMITTER SECTION OF THE T/R CIRCUIT BOARD.
2. ALL RESISTORS ARE RATED AT 1/4-WATT AND HAVE 5% TOLERANCE UNLESS OTHERWISE NOTED. RESISTOR VALUES ARE IN OHMS (K=1000, M=1,000,000).
3. CAPACITOR VALUES LESS THAN 1 ARE IN μ F (MICROFARADS). ALL OTHER CAPACITOR VALUES ARE IN pF (PICOFARADS) UNLESS OTHERWISE NOTED.
4. ○ THIS SYMBOL INDICATES A POSITIVE DC VOLTAGE MEASURED WITH A HIGH IMPEDANCE VOLTMETER FROM THE POINT INDICATED TO CHASSIS GROUND (RECEIVE MODE, NO SIGNAL INPUT).
5. □ THIS SYMBOL INDICATES A POSITIVE DC VOLTAGE MEASURED FROM THE POINT INDICATED TO CHASSIS GROUND (TRANSMIT MODE).
6. ▽ THIS SYMBOL INDICATES CIRCUIT BOARD GROUND.
7. ≡ THIS SYMBOL INDICATES CHASSIS GROUND.
8. ○ THIS SYMBOL INDICATES A SOLDERED CONNECTION TO A CIRCUIT BOARD.
9. ≧ THIS SYMBOL INDICATES A PLUG AND SOCKET.
10. REFER TO THE 'X-RAY VIEWS' FOR THE PHYSICAL LOCATION OF PARTS.

T/R CIRCUIT BOARD

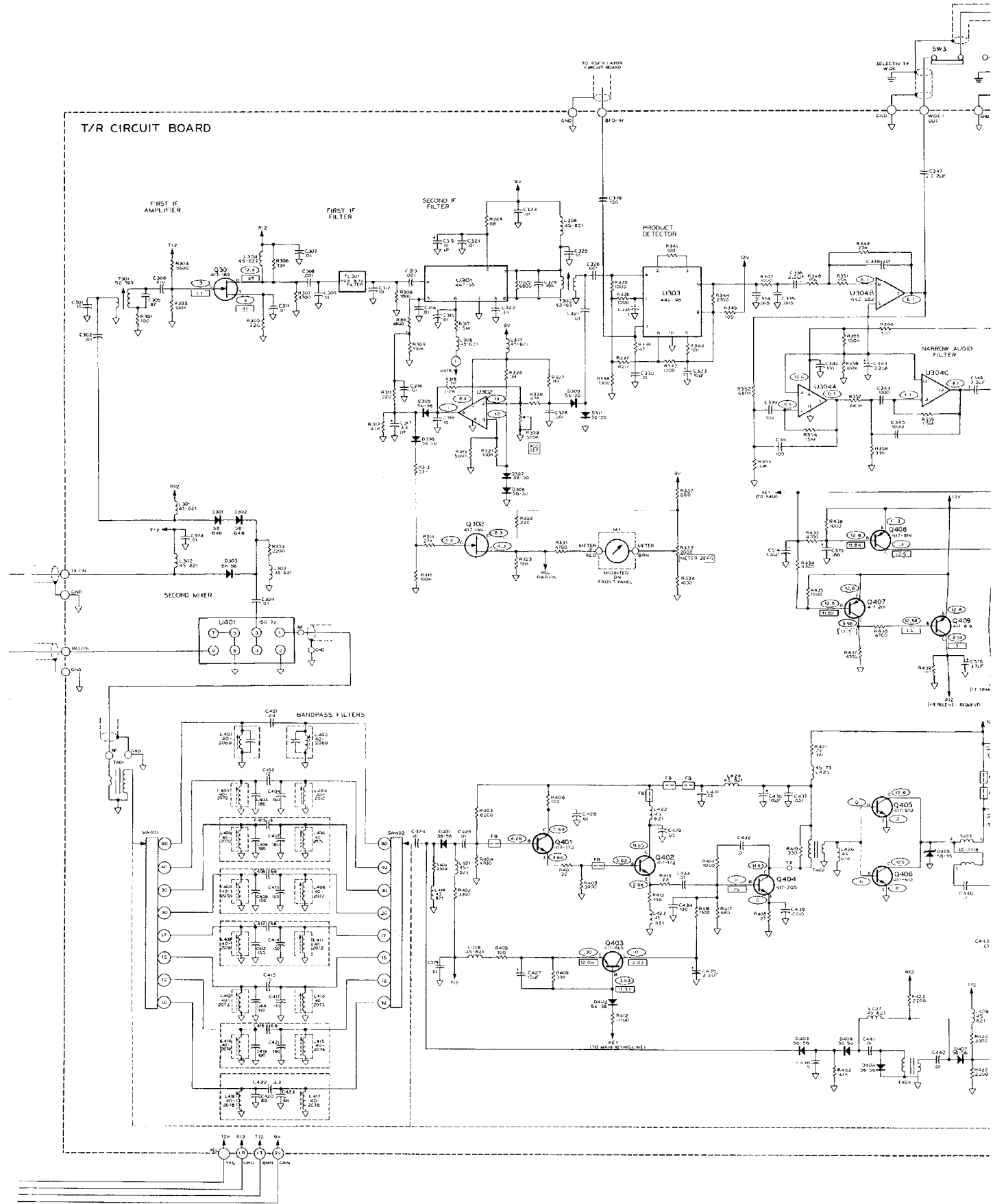

OSCILLATOR CIRCUIT BOARD

