

# ASSEMBLY AND OPERATION OF THE HEATHKIT "COMANCHE" MOBILE RECEIVER MODEL MR-1



## SPECIFICATIONS

8 Tube Superheterodyne Receiver with Intermediate Frequency Band-pass Crystal Filter.

Intermediate Frequency: ..... 3 mc.

**Frequency Coverage:**

80 Meter Band: .....	3.5 - 4.0 mc.
40 Meter Band: .....	7.0 - 7.3 mc.
20 Meter Band: .....	14.0 - 14.35 mc.
15 Meter Band: .....	21.0 - 21.5 mc.
10 Meter Band: .....	28.0 - 29.7 mc.

**Intermediate Frequency Crystal Filter:**

Center Frequency: .....	3.0 mc.
Bandwidth at -6 db: .....	3.0 kc.
Bandwidth at -60 db: .....	10.0 kc maximum.
Hermetically sealed.	

**Panel Controls: .....**

BFO tuning.  
RF gain.  
AF gain - ON - OFF.  
CW - SSB - AM.  
Noise Limiter.  
AVC.  
Main tuning.  
Band switch.  
Antenna trimmer.

Tube Complement: ..... 6BZ6 - RF amplifier.  
 6EA8 - Mixer-oscillator  
 6BZ6 - First IF amplifier.  
 6EA8 - (1/2) Second IF amplifier.  
 6EA8 - (1/2) "S" meter amplifier.  
 6BE6 - Product detector.  
 6T8 - First audio - Detector -  
 AVC - Noise Limiter.  
 6AQ5 - Audio output.  
 OA2 - Voltage regulator.

Signal to Noise Ratio: ..... 10 db at 1 microvolt sensitivity or less.

Power Required: ..... Filaments - 12 V at 1.65 amp AC or DC.  
 6V at 3.3 amp AC or DC.  
 B+ Voltage - ~~300~~ V DC at 125 ma. \*  
 Total power - 57.3 W.

Net Weight: ..... 15 lbs.

Shipping Weight: ..... 19 lbs.

Cabinet Size: ..... 6 1/8" H x 12 1/8" W x 9 15/16" D.

\* DROPPING RESISTOR REMOVED.  
 INTRODUCTION 250 VDC IS NOW REQUIRED.

The Heathkit MR-1 "Comanche" Receiver was designed to provide reliable reception of continuous wave amplitude modulated phone, code and single sideband signals on amateur frequencies in mobile service, under a wide variety of operating conditions.

The "Comanche" Receiver was primarily intended as a companion unit to the new Heathkit MT-1 "Cheyenne" Transmitter for mobile use; however, equally fine results may be attained in fixed station applications when the proper antenna and power sources are provided.

It is a superhetrodyne receiver having a basic sensitivity of less than .1 microvolt with a signal to noise ratio of approximately 10 db for 1 microvolt input on all bands. The receiver features a crystal lattice type filter at an intermediate frequency of 3 mc to obtain sharp selectivity and eliminate image response without resorting to double conversion.

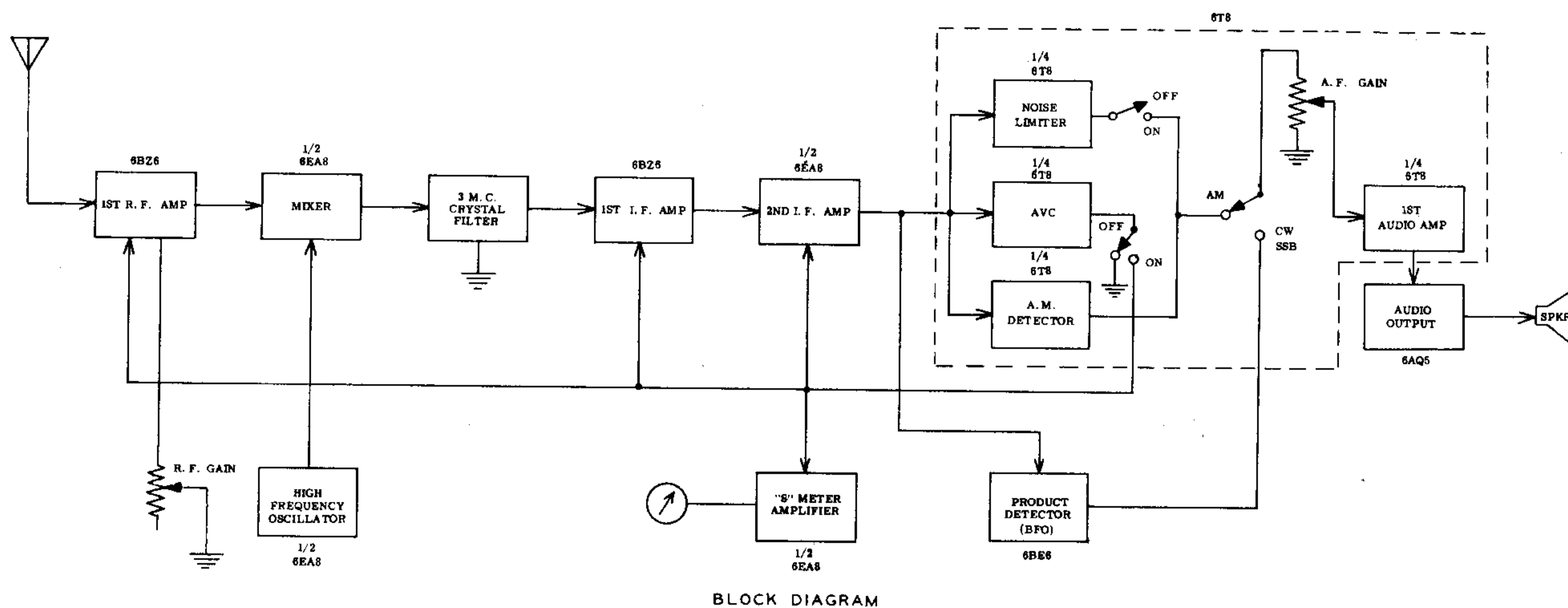

The block diagram above and the following circuit description will be invaluable to the builder in understanding the operation of the Receiver and will aid him in the later step-by-step construction of the unit.

# POWER CABLE CONNECTIONS

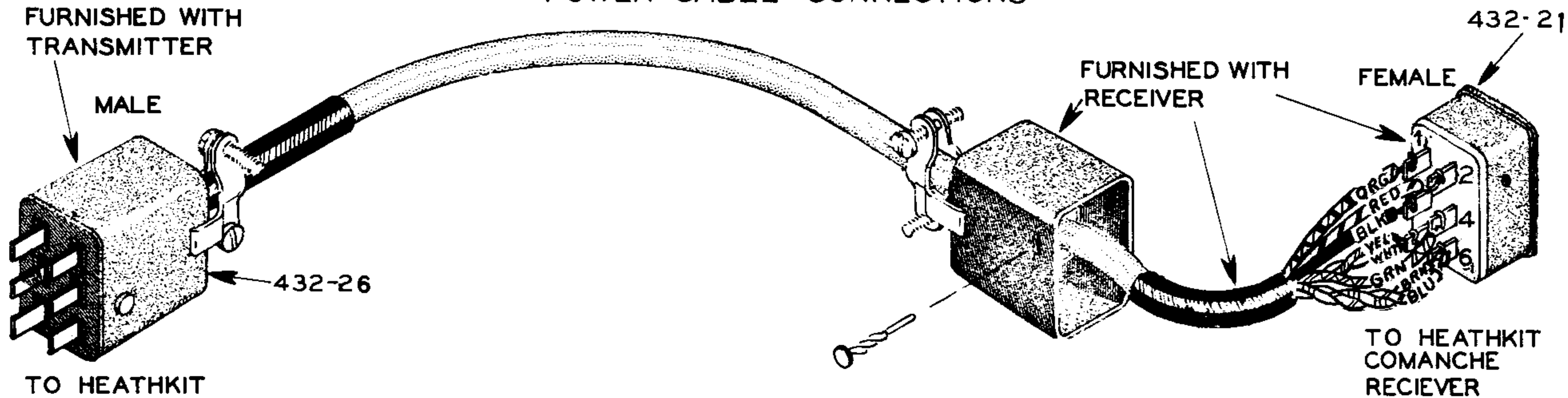

TO HEATHKIT  
CHEYENNE  
TRANSMITTER

A+	TERMINAL #5	YELLOW AND WHITE (TWIST TOGETHER TO FORM A SINGLE LEAD)
GND	TERMINAL #6	BROWN AND BLUE (TWIST TOGETHER TO FORM A SINGLE LEAD)
B+ 600V	TERMINAL #2	RED
B+ 300V	TERMINAL #1	ORANGE
GND	TERMINAL #3	BLACK
RELAY	TERMINAL #4	GREEN

Figure 33

## CIRCUIT DESCRIPTION

### First RF Amplifier

Coaxial connection is made to the input circuit, which was designed for  $52\Omega$  impedance. Three separate rosin-impregnated high Q coils with a cellulose-nitrate protective coating tune each band and all coils have been preset at the factory. The oscillator coils will require slight tuning to bring bandwidths and band edges into proper relation to the calibrated dial drum. The mixer coils require slight adjustment for tracking purposes only. A 6BZ6 remote cutoff pentode is used as a high gain radio frequency amplifier stage. This stage has AVC or MVC applied, a separate RF gain control in its cathode circuit, and both input and output circuits are tuned to provide maximum gain and image rejection. Antenna windings have grounded center taps with both primary and secondary windings switched for band changing. Ceramic band switch wafers are used for all band switching.

### Converter

The pentode section of a 6EA8 high frequency triode-pentode is used as a mixer-oscillator. This tube provides a low mixer noise level. The triode section is used for the high frequency oscillator portion of the Receiver in a tuned-grid, tuned-plate circuit which is coupled to the mixer section only by the interelectrode capacitance of the tube, thus adding to the stability of this stage. In addition, all coils have frequency-determining capacitors mounted directly upon them, and are temperature compensated to reduce drift due to heating. This section is shielded and located away from heat producing elements. Separate coils are provided for each band so that calibration and bandspreading may be done without interaction on the other bands. Each band occupies practically the full dial scale, and a three-section, two-pole ceramic band switch provides complete coverage of amateur bands, 80 through 10 meters. All oscillators have regulated plate voltages applied from the OA2 voltage regulator stage.

### IF Crystal Filter

The lattice type crystal filter, operating at an intermediate frequency of 3 mc, is directly coupled from the plate circuit of the 6EA8 mixer-oscillator stage to the input circuit of the following first IF stage. Shielding of the input and output circuits is provided by the main chassis center frame, and the unit is hermetically sealed. The band-pass characteristic of this filter is 3 kc at 6 db down and 10 kc maximum at 60 db down, with the top effectively flat and the selectivity skirts very sharp. This gives the "Comanche" a high order of selectivity.

### First IF Amplifier

Another 6BZ6 remote cutoff pentode is used in the first IF amplifier stage operating at 3 mc. This high-gain amplifier has AVC or MVC applied, with its gain fixed for optimum performance. Its output circuit is impedance-coupled to the second IF amplifier.

### Second IF Amplifier and "S" Meter Amplifier

Another 6EA8 high frequency triode-pentode is used in the second IF amplifier, with fixed gain adjusted for optimum performance. Its output circuit is impedance-coupled to the following detector stage. The triode section of this stage is used solely as an "S" meter amplifier with regulated plate voltage supplied, and is driven by signal voltage from the AVC line. AVC is selected by proper positioning of the AVC ON-OFF switch.

### Detector-First Audio-AVC-Noise Limiting

A 6T8 triple-diode-triode is used in this stage to provide the multiple functions of AM diode detection, first audio amplification, rectified AVC voltage, and series type selectable noise limiting. When product detection is used, only the triode first audio section and AVC diode in this stage are used.

### Product Detector

A 6BE6 heptode converter is used as product detector, with the IF frequency applied to its #3 grid. The #1 grid is part of a Hartley oscillator circuit which is controlled from the front panel.

The intermediate frequency and local oscillator frequency are mixed in this stage and their product appears in the output as an audio frequency. If the two are nominally zero beat with each other, the oscillator portion replaces the missing carrier for single sideband reception. If the two signals are separated by a frequency in the audible range, this results in the generation of an audible beat note for CW reception. This output is applied to the control grid of the first audio amplifier. Padding capacitors are mounted on the oscillator inductance and temperature compensation is used to hold drift to a minimum. A frequency spread of about 5 kc is available in this oscillator and the plate voltage is regulated.

### Audio Output Amplifier

A 6AQ5 beam power amplifier is used in the audio output stage, working into the audio output transformer with a primary impedance of 5000 ohms, and a secondary impedance of 8 ohms for loudspeaker operation. Audio output to an 8 ohm permanent-magnet type speaker is rated at 2 watts and audio frequencies in the voice range from 300 to 3000 cycles are given preference.

### Voltage Regulator

An OA2 tube, which holds the voltage (over its normal current range of 4 to 30 ma) constant at 150 volts, is used in this circuit to stabilize the HF oscillator and other circuits having critical requirements.

## PRELIMINARY INSTRUCTIONS

This manual is supplied to assist you in every way to complete the Receiver with the least possible chance for error. We suggest that you take a few minutes now and read the entire manual through before any work is started. This will enable you to proceed with the work much faster when construction is begun. The large fold-in pictorials are handy to attach to the wall above your work space. Their use will greatly simplify the completion of the kit. These diagrams are repeated in smaller form within the manual. We suggest that you retain the manual in your files for future reference, both in the use of the Receiver and for its maintenance.

### Proper Soldering Techniques

Only a small percentage of Heathkit purchasers find it necessary to return an instrument for factory service. Of these instruments, by far the largest proportion of malfunctions are due to poor or improper soldering.

Correctly soldered connections are essential if the performance engineered into a kit is to be fully realized. If you are a beginner with no experience in soldering, a half hour's practice with some odd lengths of wire may be a worthwhile investment.

For wiring this kit, a 75 to 100 watt iron or its equivalent in a soldering gun is very satisfactory. A lower wattage iron than this may not heat the connection enough to flow the solder smoothly over the joint. Keep the iron tip clean and bright by wiping it from time to time with a piece of cloth.

- ( ) Place a 1 1/4" knob on the AF gain control and position the red arrow on the knob perimeter over the OFF position when the control is fully counterclockwise.
- ( ) Place a 1 3/4" knob on the main tuning shaft (this knob has two setscrews).
- ( ) Place a 9/16" knob on the antenna trimmer shaft. Position the red dot on the knob perimeter straight up when the capacitor is at half mesh. Turning to the right should increase capacity and to the left should decrease capacity.
- ( ) Place a 1 1/4" knob on the band switch shaft and rotate the shaft to its extreme counterclockwise position. Line up the red arrow on the perimeter of this knob with the 80-meter band indication on the front panel and then secure the knob with the setscrew.
- ( ) Place a 9/16" knob on the noise limiter shaft and position the small red dot on the knob perimeter to coincide with the ON-OFF markings on the front panel.
- ( ) Locate the small plastic lever knob (#462-80) and slide it over the rectangular function switch lever.

NOTE: At this time it will be in order to check the tension and position of the calibrated dial drum with respect to the band switch pulley. Try rotating the band switch knob and note that the red arrow should be opposite each band indication when this band appears in the window of the front panel escutcheon. There should be enough spring tension to rotate the drum from 10 to 80 meters in a positive way. Too much tension, however, may cause the switch shaft to be actuated when not intended.

There are two problems involved in the adjustment of this dial mechanism. First, in order to change or bring into view the proper band on the calibrated dial drum with the band switch knob in its proper position, the pulley on the band switch shaft may be rotated in the proper direction to bring alignment. This pulley should then be retightened permanently.

Second, if the proper bands appear in the front panel escutcheon but there is either not enough or too much spring tension on the dial drum, this tension may be adjusted by loosening the plug button assembly on the dial drum shaft. This is done by holding the plug button and bushing at the spiral spring end of the dial drum and loosening the 6-32 BHMS, then rotating the drum in the proper direction and retightening the bushing setscrew permanently.

These adjustments may be done to suit your personal satisfaction and should be made permanent at this time. Attention to these mechanical details will result in a smooth operating dial mechanism.

- ( ) Locate the label (#390-62) and mount on the rear apron, as shown in Figure 32.

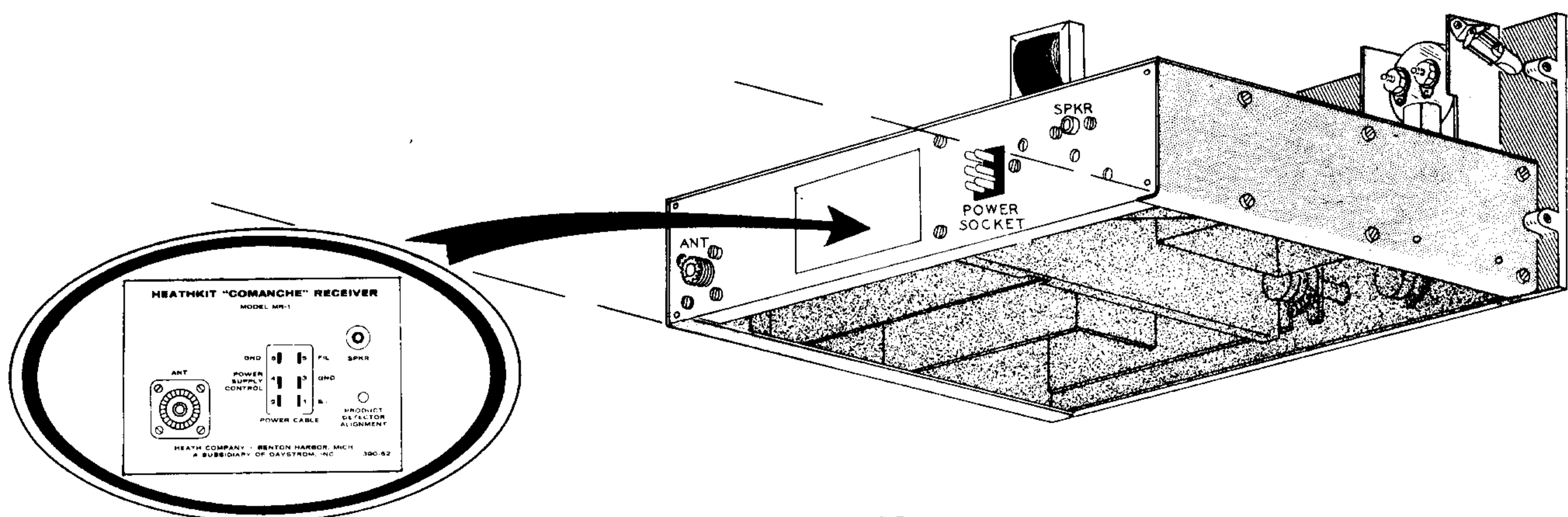
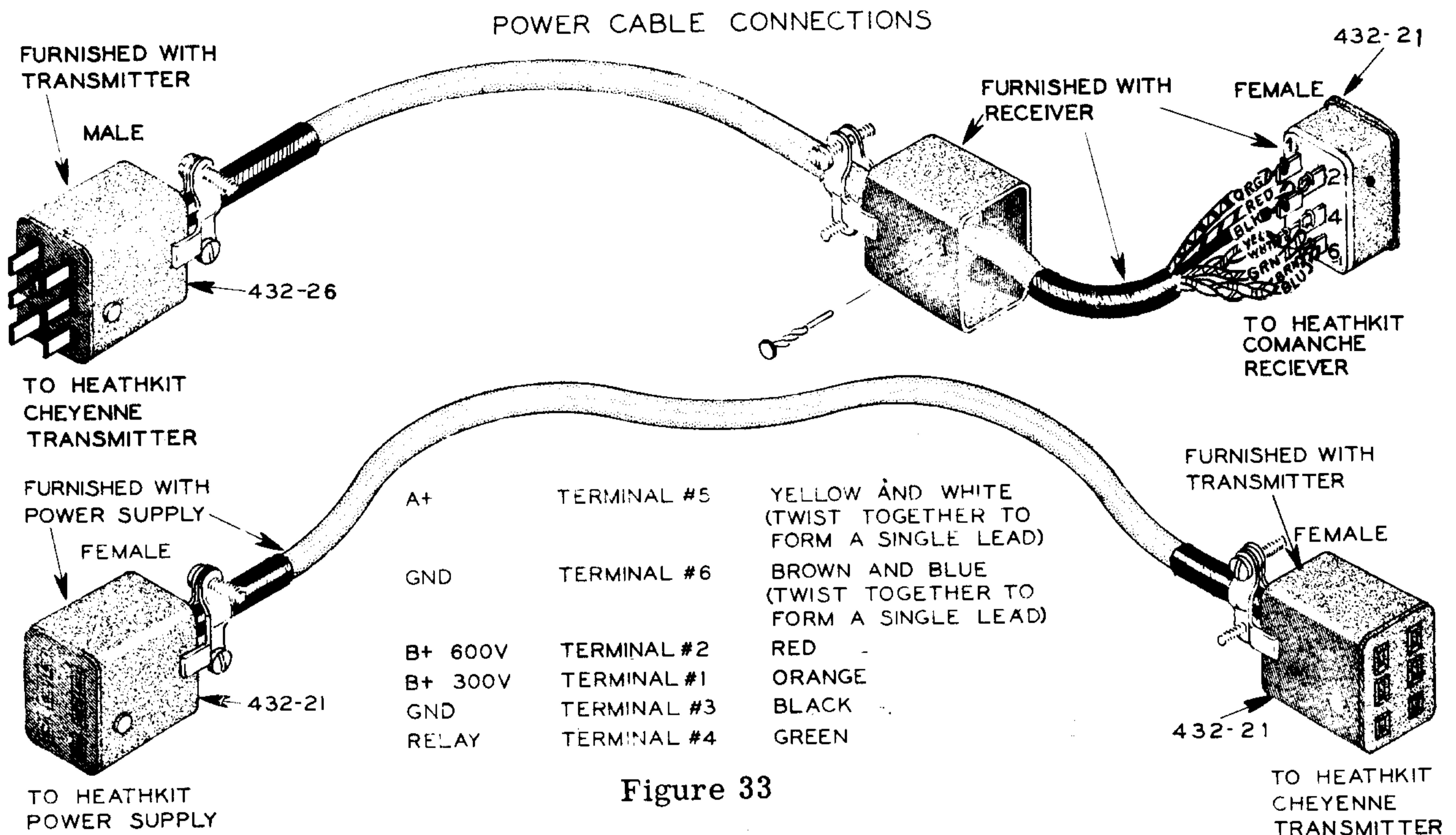

Figure 32



Refer to Figure 33 for the following steps:

- ( ) Locate the Jones 6-prong cable socket (#432-21) and the 3' length of 8-conductor cable.
- ( ) Remove the outer jacket of the 8-conductor cable at both ends, for a length of 3/4".
- ( ) Remove 5/16" on each of the 8 conductors within the jacket. After removing the insulation, tin each conductor lightly to hold the strands together.
- ( ) Remove the cable socket cover pin releasing the socket cover.

NOTE: This drawing shows connection to the Receiver. The female cable socket is furnished with the Receiver, together with a 3' length of 8-conductor cable. If you intend to use the Mobile Power Supply and "Cheyenne" Transmitter with your "Comanche" Receiver, you will find the other cables and plugs (with the exception of coaxial cables and plugs) in the Transmitter kit or in the Transistor Power Supply kit.

The following connections are made to correspond to those which will be made if the kit builder intends using the "Cheyenne" Transmitter and Mobile Power Supply. These same connections may be used for other mobile power supplies and fixed station power supplies.

- ( ) Place a 2" length of 1/4" black insulated sleeving over the cable.
- ( ) Place the socket cover on the cable as shown.
- ( ) Connect the red wire to pin 2 on the cable socket (S-1).
- ( ) Connect the orange wire to pin 1 (S-1).
- ( ) Connect the black wire to pin 3 (S-1).
- ( ) Connect the green wire to pin 4 (S-1).
- ( ) Connect the yellow and white wire to pin 5 (S-2).
- ( ) Connect the brown and blue wire to pin 6 (S-2).

- ( ) Slide the sleeving as close as possible to the cable socket.

- ( ) Replace the socket cover and cover pin. Tighten the cable clamp screws.

An examination of the label on the rear panel will show that pin 1 is B+, pin 3 is ground, pin 5 is the filament supply, pin 6 is ground, and pin 4 is the power supply control which normally starts the transistor power supply into operation when in mobile service. No connection is made to pin 2 in the Receiver and this pin is not used at the Receiver power cable terminal in the Transmitter.

- ( ) The speaker plug (#438-4) fits the speaker jack on the rear panel of the "Comanche" Receiver. See Figure 32. As stated previously, no speaker is furnished with the "Comanche" Receiver, but the kit builder undoubtedly has in mind by this time a speaker of 8 ohms voice coil impedance for use with his kit.
- ( ) Low impedance, single conductor wire with an outer shield braid can be used for connection to the speaker, in which case the center conductor should now be fastened to the center pin of the speaker plug and the outer shield braid should be connected to the outer body of the speaker plug.

DO NOT OPERATE THIS RECEIVER WITHOUT SPEAKER CONNECTED. DAMAGE TO THE OUTPUT TRANSFORMER MAY RESULT.

DO NOT REMOVE TUBES WITHOUT TURNING OFF RECEIVER.

This completes wiring and assembly of your "Comanche" Mobile Receiver MR-1.

#### PRELIMINARY CHECKING

Although the MR-1 "Comanche" Receiver was designed for use with the MP-1 Power Supply primarily, other power supplies may be used provided proper voltages and currents are delivered to the Receiver.

It should be noted here, referring to the power cable connections shown by the label on the rear apron, that if other sources of power are used, B+ must be supplied to pin 1 of the power cable. Filament voltages must be supplied to pin 5 of the power cable, and whether 6 or 12 volt filament operation is contemplated will depend on which of the two values were used to wire the Receiver filament circuit (refer back to the wiring of the filament circuits). Pins 3 and 6 are both ground. Pin 4 is the power supply control and it is the grounding of this pin which turns on the MP-1 Mobile Power Supply.

It is assumed in the following steps that the MP-1 Mobile Power Supply is being used in connection with the MR-1 "Comanche" Receiver and the MT-1 "Cheyenne" Transmitter.

After supplying power to the Jones plug on the rear apron, turn the AF gain control to the right. This control turns the MP-1 Power Supply on and delivers both filament and plate voltage to the Receiver. If nothing unusual happens which might indicate short circuiting of any of the components, then proceed with the following steps covering calibration, final adjustments, installation and operation.

Should trouble develop at this point, refer to the chapter titled, "In Case Of Difficulty-Troubleshooting".

#### "S" METER SETTING

With power applied to the Receiver and the AVC switch in ON position, the "S" meter should swing from the 60 db position to the "O" S unit position. This meter reads current in the cathode of the triode section of the 6EA8 second IF and "S" meter amplifier. The adjusting potentiometer (#11-30) mounted on top of the chassis is in parallel with the "S" meter and is adjusted so that the meter reads "O" S units with no signals applied to the Receiver, and with the RF gain control set fully clockwise. In AVC OFF position, and also when power is removed from the Receiver, the meter pointer normally rests at the 60 db position. The meter adjusting screw, available through the front panel, is used to zero the pointer, if this becomes necessary.

When it has been determined that the pointer is in proper resting position, and power is applied, turn the meter adjusting potentiometer (#11-30) until the pointer indicates "O" S units. Try the AVC ON-OFF switch to determine that this switch functions normally, indicated by the pointer coming to rest in the 60 db position. This completes setting of the "S" meter.



The "S" meter in the "Comanche" Receiver has been designed to show an S9 signal level when the signal strength entering the Receiver is equal to 100 microvolts. This calibration will be approximately the same on all bands.

### FINAL CALIBRATION AND ADJUSTMENT

Preliminary to calibration, make sure that the steps in assembling and aligning the tuning mechanism are properly done. When the main tuning shaft is in extreme counterclockwise position, the plates of the main tuning capacitor should be at full mesh. It is also important at this time that you check the pointer travel so that the pointer will have approximately equal distances at each end when the main tuning shaft reaches its "stop" locations. Make sure also that the pointer is firmly fastened to the dial cord so that it will not move when the following calibration steps are accomplished. Bend the center tab up to secure, being careful not to cut the dial cord.

If the kit builder has access to a frequency standard of the LM or BC surplus series, or an RF signal generator capable of a range of from 3 mc to 30 mc with modulation, these are all excellent instruments with which to calibrate the MR-1 Receiver. It is important to allow the frequency standard and the Receiver to warm up for at least half an hour before beginning calibration. Both units will then be at, or near, operating temperatures and settings will be more reliable and accurate. If a fixed power supply is not available, the MP-1 Power Supply may be connected to the car battery and a charger of 10 amperes capacity connected to the battery to keep it from running down while making adjustments.

Panel controls should be set as follows:

<u>CONTROL</u>	<u>SETTING</u>
AVC .....	ON
Function .....	AM
RF gain .....	Full clockwise
AF gain .....	2/3 clockwise
Tuning .....	Any position
Antenna trimmer .....	Any position
Noise limiter .....	OFF
Band switch .....	80 meters

Note from Figure 30 that trimmer capacitors C10, C15, C20, C40 and C80 are used to determine the frequency spread of their respective coils, as covered on the corresponding bands shown on the dial drum. Coil slugs O10, O15, O20, O40 and O80 are used to set the low frequency point of calibration on the dial drum.

The coil slugs are set to the calibration frequency near the low end of the dial, and the trimmers are adjusted so that the calibration frequency at the high end of each band coincides with its respective dial reading. These two adjustments interact with each other and will, therefore, have to be adjusted alternately until optimum overall calibration is obtained. All of the trimmer capacitors should be set at half-scale (the small arrows in the ceramic rotors 90° away from the mounting screws) before beginning calibration.

Set the signal generator for 3 mc output with modulation, and connect the ground lead to the chassis and the "hot" lead through a .01 mfd blocking capacitor to pin E2 of the 6EA8 mixer. Use the small plastic hexagonal alignment tool furnished to turn the IF transformer slugs AA and AB from the top until a maximum "S" meter reading or audible signal, is obtained.

If you find it difficult to hear an audible signal try tuning the generator a little to both sides of 3 megacycles inasmuch as the crystal filter band width is very narrow and could be missed unintentionally. This completes the alignment of the intermediate frequency stages.

Alignment of the high frequency oscillator will be performed next.

10 Meters - Coil O10 and trimmer capacitor C10 control the frequency and the spread of the oscillator on this band, which tunes from 25 mc to 26.7 mc.

- A. Make sure the band switch is in the 10-meter position and the pointer is over the 28 mc mark on the dial drum. Now apply a 28 mc signal to the antenna terminal. It may be necessary to again "rock" the generator above and below the 28 mc point to get a peak reading on the "S" meter, or to hear an audible signal. Once either a peak reading or an audible signal is obtained, turn the antenna trimmer control until the signal is maximum.
- B. Note whether the signal is above or below the 28 mc on the generator. Adjust coil slug O10, moving the generator signal in the proper direction until the 28 mc signal is audible when the pointer is opposite the 28 mc location on the dial drum. Now tune the Receiver to the high end of the band and determine if the 29.7 mc generator signal point is high or low on the dial. Adjust the trimmer capacitor C10 until the generator signal can again be heard at this setting on the Receiver. After moving the adjusting trimmer capacitor, it will be found that upon returning to the low end of the band the low point may be off frequency, with respect to the dial reading. It will again be necessary to adjust coil slug C10 to bring the low frequency reading to the 28 mc point at which the pointer is set. Again the high frequency reading must be checked to make sure that the pointer is opposite 29.7 mc at the corresponding generator signal reading.

This procedure for calibrating and spreading each band should be repeated until the calibration points at each end are squarely under the pointer at the corresponding frequency readings on the Receiver. As explained previously, the setting of coils and trimmers interact, one with another, and therefore these adjustments are made until the bandspreading and fixed frequency points agree with the dial drum readings.

- C. With the Receiver still set on the 10-meter band, the dial pointer should be set at mid-scale frequency reading and the generator tuned in. Again tune for maximum signal strength with the antenna trimmer control. At this setting, coil slug M10 should be adjusted for maximum signal. This setting will track the mixer stage tuning with the high frequency oscillator so that signal strength will be uniform at the low as well as at the high end of each band. It is possible to obtain two peaks in adjusting this coil. Be sure the peak with the coil slug highest in the coil form is used.
- D. Coil A10 is the 10-meter antenna coil. This antenna coil has been preset and requires no further adjustment.

15 Meters - Coil O15 and trimmer capacitor C15 control the frequency and spread of the oscillator on this band, which tunes from 18 mc to 18.5 mc.

- A. Repeat step A above, making sure that the band switch is in the 15-meter position and that the signal generator is in the 21.0 to 21.5 mc region.
- B. Repeat step B above, with the lower band edge at 21 mc and the upper band edge at 21.5 mc.

- C. Repeat step C above, with the Receiver set at mid-scale on this band. At this setting, coil slug M15 should be adjusted for maximum signal. Again be sure to use the peak with the coil slug highest in the coil form.
- D. Repeat step D. No adjustment of the antenna coil is necessary.

20 Meters - Coil O20 and trimmer capacitor C20 control the frequency and spread of the oscillator on this band, which tunes from 11 mc to 11.35 mc.

- A. Repeat A above, making sure the band switch is in the 20-meter position and that the signal generator is in the region of 14.0 mc to 14.35 mc.
- B. Repeat step B above, with the lower band edge at 14.0 mc and the upper edge at 14.35 mc.
- C. Repeat C above, with the Receiver set at mid-scale on this band. At this setting, coil slug M20 should be adjusted for maximum signal. Again use the peak with the coil slug highest in the coil form.
- D. Repeat step D. No adjustment of the antenna coil slug is necessary.

40 Meters - Coil O40 and trimmer capacitor C40 control the frequency and spread of the oscillator on this band, which tunes from 4.0 mc to 4.3 mc.

- A. Repeat step A above, making sure the band switch is in the 40-meter position and the signal generator is in the region of 7.0 mc to 7.3 mc.
- B. Repeat step B above, with the lower band edge at 7.0 mc and the upper band edge at 7.3 mc.
- C. Repeat step C above, with the Receiver set at mid-scale on this band. At this setting, coil slug M40 should be adjusted for maximum signal.
- D. Repeat step D. No adjustment to the antenna coil slug is necessary.

80 Meters - Coil O80 and trimmer capacitor C80 control the frequency and spread of the oscillator on this band, which tunes from 6.5 mc to 7.0 mc.

- A. Repeat step A above, making sure the band switch is in the 80-meter position and the signal generator is in the region of 3.5 mc to 4.0 mc.
- B. Repeat step B above, with the lower band edge at 3.5 mc and the upper band edge at 4.0 mc.
- C. Repeat step C above, with the Receiver set at mid-scale on this band. At this setting, coil slug M80 should be adjusted for maximum signal.
- D. With the generator and receiver set at 3.5 mc and the antenna trimmer capacitor at full mesh, adjust coil A80 for maximum "S" meter reading.

3 mc Product Detector - Set the band switch to the 20-meter position and insert at the antenna terminal a signal in the 14.0 to 14.35 mc region. Peak the antenna trimmer and set the function switch in AM position, with AVC ON. The signal from the generator should be modulated at this point.

- A. Find the signal from the signal generator by tuning the Receiver so that a peak reading is indicated on the "S" meter. Reduce generator output or Receiver RF gain until a center-scale reading is obtained.
- B. Now, with AVC still ON and with the function switch in the CW position, set the BFO knob on the front panel so that the arrow is straight up to the center mark. At this point the BFO capacitor should be exactly half mesh. Remove modulation from the signal

generator and adjust coil slug OD by inserting an insulated tuning tool through the adjusting hole on the rear apron until the audible note heard is at zero beat with the signal generator. When the frequency of the product detector is only a few cycles away from the generator frequency, it may be possible to see the "S" meter actually "pulse", indicating the difference between the two signals in cycles per second.

When the two signals (generator and BFO) are the same, the product detector will be set at 3 mc in the center of its tuning range. Increasing the tuning capacity will lower its frequency and decreasing the tuning capacity will raise its frequency. Check to see this capacitor moves in the proper direction according to the front panel markings. The white dots to the right and left of center indicate approximately 1500 cycles above and below the 3 megacycle intermediate frequency. The total spread available in this oscillator will be about 5000 cycles.

NOTE: Be sure to recheck the setting of the 3 mc product detector after it is installed in its cabinet. Upon installation in the cabinet, the additional surrounding metal surface will cause the frequency to shift, and the oscillator may be reset to zero beat again by using a tuning tool through the hole available in the rear apron.

This completes calibration and alignment of your MR-1 Mobile Receiver.

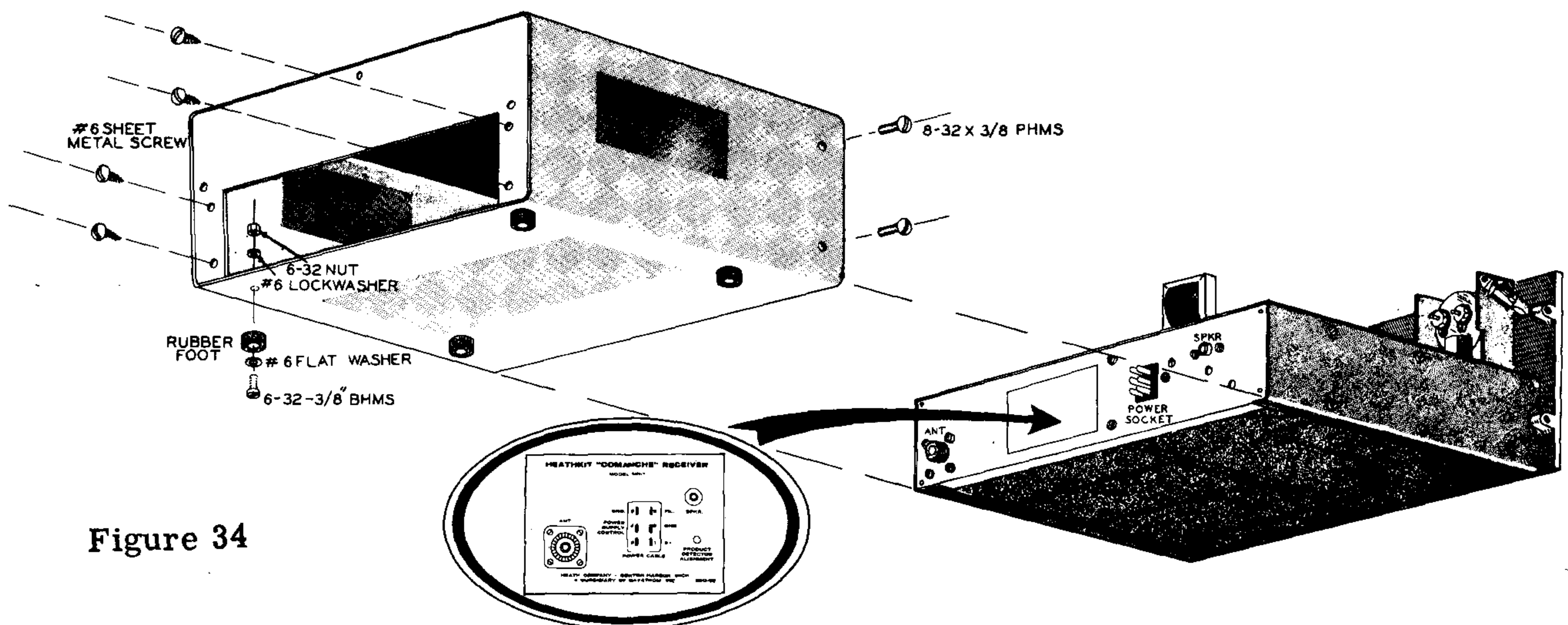

Figure 34

Refer to Figure 34 for the following steps:

- ( ) Locate the cabinet (#90-100) which is furnished for your Receiver and note that there are four screw holes in the bottom to which rubber feet are attached.
  - ( ) Using a 6-32 x 3/8" BHMS, place upon the screw a small #8 flat washer and then a rubber foot, with the screw head into the depression in the foot.
  - ( ) Now place the screw through the hole in the bottom of the cabinet and secure from the inside with a #6 lockwasher and 6-32 nut.
  - ( ) Repeat the above step for each of the other three rubber feet to be mounted.
- NOTE: The pilot light shrouds may be positioned to avoid glare under night driving conditions.
- ( ) Now slide the completed Receiver into the front of the cabinet, using care so that the front panel is not marred during this operation.
  - ( ) Fasten the cabinet to the chassis rear apron with four #6 sheet metal screws, as shown.
  - ( ) Fasten the front panel to the cabinet sides, using four 8-32 x 3/8" pan head machine screws, and tighten securely.

You are now ready to install your Mobile Receiver. Following are some notes on this installation.

## INSTALLATION

The MR-1 "Comanche" Mobile Receiver was designed to be used as a companion unit with the MT-1 "Cheyenne" Transmitter and the MP-1 Transistor Power Supply. The Receiver requires that the source of filament current be applied continuously, and that plate voltage be supplied when in normal receiving condition. The self-contained relay located in the MT-1 "Cheyenne" Transmitter switches the plate power from the Receiver to the Transmitter, as well as switching the antenna from the Receiver to the Transmitter. The MP-1 Transistor Power Supply is turned on initially by the AF gain control on the Receiver.

The Transmitter-Receiver combination will average about 8 amperes from the car battery. The Transmitter may draw as much as 20 amperes on modulation when both are powered by the MP-1 Transistor Power Supply. This Power Supply delivers a dual voltage of 600 volts at 150 ma and 300 volts at 100 ma. The Receiver was designed around the low voltage source, and will be most efficient at this level.

Note that the "Comanche" Receiver and "Cheyenne" Transmitter cabinets are so designed that they may be bolted together and mounted under the dash, and over the center hump, of most automobiles. A method of mounting the two together in this fashion is illustrated in Figure 35. This makes a very neat, attractive and compact installation and is offered only as a suggestion. It is realized that the mounting requirements may vary considerably. For example, the two units could be mounted side by side in some automobiles. This may, however, not be possible in many cases. For most installations, mounting the Transmitter above the Receiver and bolting the cases together, using the Heath mounting bracket Model AK-6 (available from the Heath Company), will provide a convenient means to handle the installation for the average operator. This phase of installation is left to individual choice and usually may be accomplished through the use of simple brackets and average home tools.

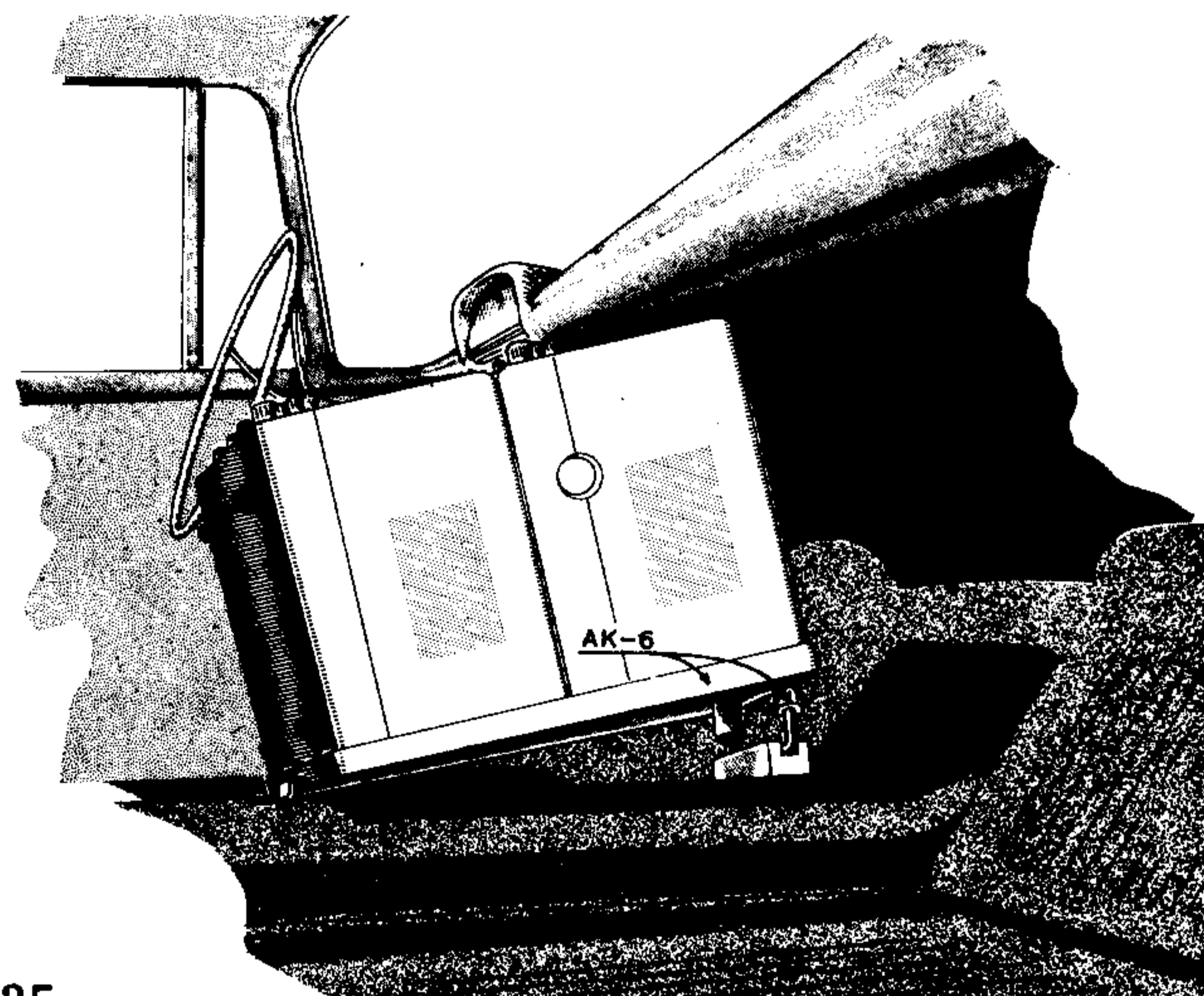
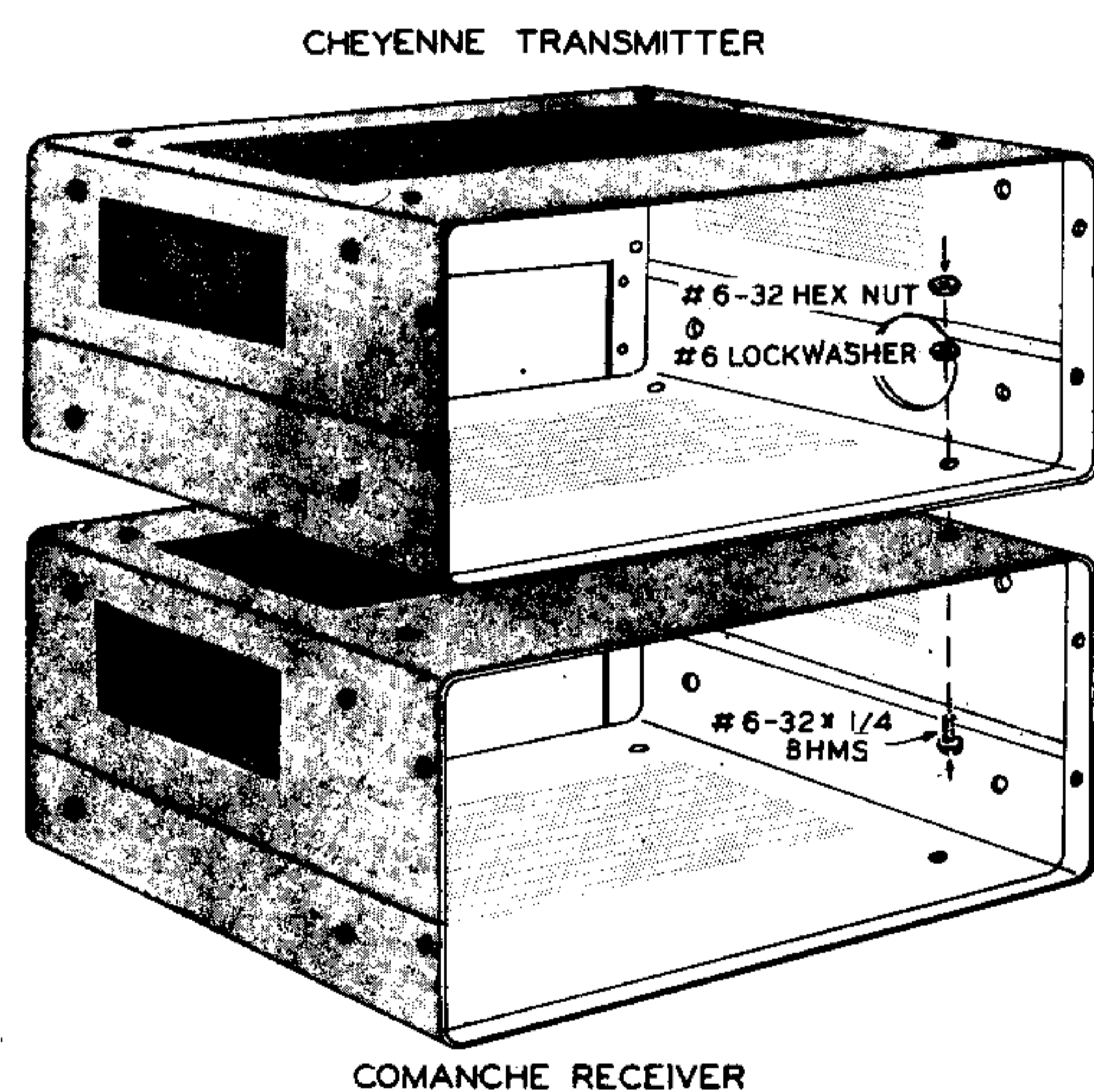

Figure 35

One of the more important things to remember is that the leads running from the car battery to the power supply should be at least #12 wire, and the two filament leads from the power supply to the Receiver should be #18 wire. Two #22 leads are paralleled in the cable supplied with the power supply to provide adequate current carrying capacity. The remainder of the power leads may be as small as #22 wire, with no undue voltage losses. Appropriate cable is included with the MP-1 Transistor Power Supply, as well as Jones type plugs for interconnecting the two.

The most serious problem encountered in mobile installation is that of noise. Such noise may originate from several sources and it is important for the operator to seek these out in a "process of elimination" manner in order to solve the individual problems. Two main sources are the ignition system and the generator-regulator system. Other noises may be generated by primary and secondary electrical circuits of the car, or may originate as static electricity caused by movement of the car. Complete elimination of ignition noise cannot be accomplished since

radio frequencies must be generated by the ignition system or no ignition would result. This noise, however, can be greatly reduced through the use of resistor spark plugs, or suppressors, which are commercially available. This problem may manifest itself to a greater or lesser degree depending on the particular automobile involved, and it is suggested that the new mobile operator consult one of the several mobile handbooks that are readily available. Some late model automobiles come equipped from the factory with suppressor type ignition cable. One method of treating the voltage regulator is shown in Figure 36. It may also be pointed out that both the MR-1 "Comanche" Receiver and the MT-1 "Cheyenne" Transmitter will serve very nicely as fixed station units. Standard dual voltage DC power supplies may be used in fixed station operation. For best results, it is strongly recommended that the antenna and transmission line system present an unbalanced  $50\Omega$  load to the Receiver input circuit. In mobile service this system is required and most commercial or fixed station antennas using beams, verticals and trap antennas are designed to be fed with either 50 or  $75\Omega$  coaxial cable. If an antenna with a balanced feed line is desired, it is recommended that a set of balun coils, such as the Heathkit Model B-1, or an antenna coupler be used.

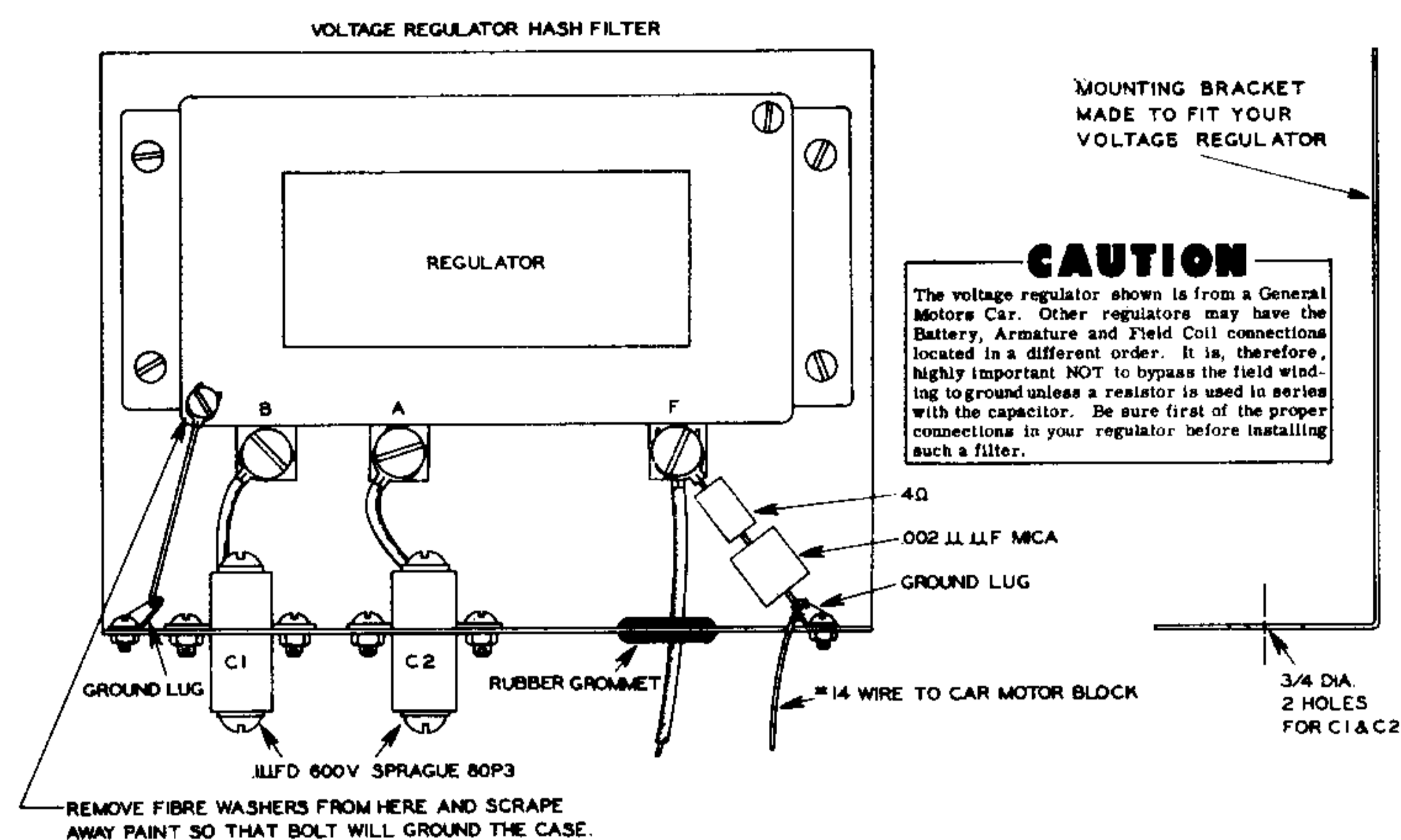

Figure 36

Much has been published on the subject of antennas and excellent articles can be found in the "ARRL Handbook", the "Radio Handbook" and in most issues of "CQ" and "QST".

#### OPERATION

**AUDIO GAIN:** Advancing the control from full counter clockwise position turns on the power supply and controls the audio volume of the Receiver. Upon examination of the schematic, it will be apparent that one set of contacts on the rear of this control closes the filament circuit. The other set of switch contacts grounds the line which leads to the relay located in the MP-1 Transistor Power Supply. When the relay closes, low voltage B+ is supplied to the Receiver. The filament line proceeds directly from the battery through the 8-conductor cable supplied, and the line is fused internally in the Receiver.

**STANDBY RECEIVE:** In normal operation, when this unit is used with the MT-1 "Cheyenne" Mobile Transmitter, simply pressing the microphone button actuates a relay located in the Transmitter, which removes B+ from the Receiver but allows the filament voltage to remain constant. When the microphone button is released, the Transmitter is automatically disabled and low voltage B+ is returned to the Receiver B+ line. Since there is no standby receiver switch on the front of the unit, if the MR-1 Receiver is used in fixed station application without the accompanying MT-1 "Cheyenne" Transmitter, it will be well for the kit builder to provide an external switching arrangement.

**RF GAIN:** This control provides a means of varying the gain of the first RF stage only. In general, especially on AM signals, it should be full ON. However, when copying single sideband or CW signals, or extremely strong AM signals, this control may be backed off to prevent blocking of the Receiver.

**SELECTIVITY:** The crystal lattice type IF filter operating at 3 mc has a band-pass of only 3 kc. The skirts on this filter are extremely sharp, attenuating all signals both sides of center frequency when they fall outside of the band-pass width. This bandwidth provides good quality on AM and single sideband, however, when working CW the selectivity may be made much sharper by varying the BFO control to either side of the IF frequency, depending on the QRM encountered.

**BAND SWITCH:** This control changes oscillator, mixer and antenna coil-capacitor combinations, with the 80-meter band in extreme counterclockwise position and the 10-meter band in extreme clockwise position.

**CALIBRATION:** There is no panel calibration control, however, calibration on each band is independent, one from another, and can be set with the oscillator coil slugs and trimmers to cover the bands individually, including bandspread. Once set, aside from warmup periods, calibration should be no problem. Calibration and alignment are covered in a special section of this manual.

**ANTENNA TRIMMER:** This control tunes the input to the first RF amplifier and should be adjusted for each band as used. On some bands, particularly 80, 15 and 10 meters, it may be necessary to adjust this trimmer when working the extreme ends of the bands, due to the relatively wide coverage in frequency.

**NOISE LIMITER:** A switch on the front of the panel inserts a series type noise limiter to attenuate excessive ignition or line noise. Inasmuch as all noise limiters are essentially clipper circuits with a preset threshold of clipping, they will tend to clip modulation peaks in some cases. Such clipping introduces a small, but unavoidable, amount of distortion, therefore, the noise limiter should be used only when necessary. If the signal is weak, there will be very little distortion, but if the signal is strong the top of the waveform may be flattened, resulting in distortion. In such cases, it is suggested the RF gain be reduced to bring the input signal level below the preset clipping level.

**AVC:** This control allows the Receiver to operate with automatic control of the RF gain, the incoming signal controlling the Receiver sensitivity. In the OFF position, the Receiver is operating at maximum sensitivity, providing the RF gain control is set at maximum. In the "Comanche" AVC system, the incoming signal must reach a predetermined level before the AVC will act. This system permits maximum gain on very weak signals, with the greatest control action taking effect on moderate and strong signals and is, therefore, known as "delayed AVC". The system is so proportioned that it can be left in operation on single sideband and CW signals as well as on AM signals. As long as the AVC switch is in the ON position, the "S" meter will continue to indicate received signal strength. In the OFF position, the AVC control is removed from the line and the "S" meter will fall to its resting position. The "S" meter is actuated from the AVC voltage developed and amplified.

**CW-SSB-AM:** This lever switch changes the form of detection used. In the AM position detection is accomplished in a diode detector which rectifies the incoming signal, removing the audio component from the RF carrier. The audio is then fed to the first audio amplifier and proceeds in a conventional manner through the audio power output amplifier. In the CW-SSB position, a heptode converter is used as a local oscillator and mixer. Within this tube the signal and the local oscillator (BFO) are combined and the product of the two is passed on to the first audio amplifier, hence the name "Product Detector".

**BFO:** This front panel control sets the frequency of the beat frequency oscillator. It may be used in several ways; First, when two CW stations are close in frequency the BFO control may be varied to reduce one or the other signal to zero beat where it becomes inaudible allowing the other signal to be copied. Second, on SSB signals the BFO can be carefully set to the Intermediate Frequency of 3 megacycles and left in this position. Now, upper or lower sideband stations may be copied by simply tuning their upper or lower sideband. Third, the BFO frequency may be set to the upper or lower white panel marking. The full crystal filter bandwidth of 3 kc can be employed in this manner and the attenuation of the other sideband should be maximum in this position. Fourth, when copying CW stations the BFO may be set to either side of the Intermediate Frequency so that a possible heterodyning signal appears at the crystal filter in such a manner as to be greatly attenuated, producing a "single-signal" effect.

### **TUNING AM SIGNALS**

Set the Receiver for AM operation with the lever switch in AM position, the RF gain control full ON, the AVC ON and audio gain control to the desired audio volume. Select the band desired with the band switch, adjusting the antenna trimmer for maximum signal or background noise in the event that no signal is present.

When tuning a station, tune for maximum "S" meter reading. If the signal is covered up with QRM, it is possible to still read the station by varying the tuning to the left or right of center frequency, although the best quality will be in maximum "S" meter reading position. Under conditions of heavy impulse noise similar to auto ignition noise, the noise limiter can be used. Frequency or phase modulated signals can be received by tuning such signals slightly off of the station's frequency. This is known as "slope detection". On extremely strong signals from local stations, the RF gain control can be reduced, together with the audio gain control, to provide a comfortable audio level.

### TUNING SSB SIGNALS

Again, the Receiver is set for the band desired and the lever is set in CW-SSB position. The BFO is adjusted to upper or lower sideband if a 3 kc bandwidth is desired or to the intermediate frequency of 3 mc if a 1.5 kc bandwidth is desired. AVC may be either ON or OFF. Adjust the antenna trimmer for maximum signal or background noise.

The main points in tuning SSB signals are first, to determine which sideband is being transmitted and second, to tune slowly. The Receiver must be tuned to the sideband station's frequency within a few cycles, or distortion will result. In AM station reception, both the carrier and sidebands are received and the carrier is properly oriented in respect to the sidebands. However, with an SSB signal the local receiver oscillator supplies the missing carrier and the received station supplies one sideband. Consequently, the Receiver must be tuned very carefully so that the "local oscillator" is properly oriented with respect to the received sideband signal. If the "local oscillator" is positioned 50 cycles high or low, the sideband modulation will be the resultant 50 cycles high or low, and will produce the "monkey chatter" or "Donald Duck" effect commonly associated with SSB reception.

Remembering that the Receiver local oscillator must be tuned within a few cycles out of several megacycles, the operator must practice careful and slow tuning to receive SSB stations. However, as the operator becomes more familiar with this type of signal, its characteristics and the Receiver controls, properly transmitted SSB signals can sound as good as properly transmitted AM signals. In addition, because the Receiver may be operated at reduced RF gain, much of the noise present in AM reception will be absent in SSB reception. It may be noted here that most SSB stations use the lower sideband on 80 and 40 meters and the upper sideband on 20, 15 and 10 meters. If the Receiver is tuned to the wrong side of the SSB signal or if the beat frequency oscillator is not adjusted properly, it will be impossible to tune such a station clearly. Practice in using these controls will provide more information than can be set forth in this manual. Needless to say, on strong SSB station signals, the RF gain should be reduced for better quality reception.

### TUNING CW SIGNALS

The Receiver is again set up the same as for SSB operation and may be used with AVC ON or OFF. Normally, it will be found more suitable to advance the audio gain to a higher level and reduce the RF gain when receiving CW and SSB signals. The BFO may be used at its center frequency on which it was previously set for SSB reception, or may be moved to one side or the other, depending on the interference encountered from adjacent signals. Many times interfering signals may be attenuated by moving the BFO controls to one side and retuning the signal on the Receiver dial.

### IN CASE OF DIFFICULTY - TROUBLESHOOTING

These subjects will be dealt with first generally, then more specifically in chart form. While both the general comments and specific chart indications will cover some of the trouble more commonly encountered, it must be realized that it is practically impossible to list all of the difficulties which could occur.

Observing a few basic procedures will aid you in correcting troubles not shown on the chart. In this area, service instruments are of value, but not absolutely necessary.



Visually inspect the wiring and soldered connections throughout the Receiver, making sure there are no loose or poorly soldered joints. It is of interest to note that about 90% of kits returned for repair are defective due to poorly soldered connections. Many troubles can be eliminated by reheating such connections, making sure they are soldered in accordance with illustrations found under the section "Proper Soldering Techniques" in the manual.

It is often helpful to have a friend read from the manual while you recheck the connections, and together compare your work with the Step-By-Step Instructions and the Pictorials, since someone not familiar with the unit may notice something consistently overlooked by the kit builder. It is also helpful to mark the Pictorial with a colored pencil as each lead and component is checked to eliminate the possibility of omitting or misplacing a connection or component.

IF transformers are identified by part number and should be checked for proper position. Tube numbers should also be checked to ensure their being in the proper sockets. All tube filaments should light upon application of filament voltage.

Due to the compact arrangement of mobile units and the small terminal strips used, it is very important to make sure that these terminals, or wires leading to or from them, touch no other terminals. Such misplacements would cause trouble which is very difficult to isolate. Other components being small physically may present similar problems unless care has been exercised in the initial wiring.

Since no power supply is incorporated with this unit, all sources of filament and plate power must enter through the 6-prong power plug on the rear apron of the Receiver. The sources of power may easily be checked by measuring them where they enter the Receiver to determine if they are satisfactory at this point.

If difficulty is experienced in securing an audible signal, it may be pointed out that an audio signal applied to the grid of either the 6AQ5 output stage, or the grid of the 6T8 first audio stage, should produce an audible signal in the loudspeaker.

If, after careful checking, the difficulty is still not located and a volt-ohm-milliammeter is available, voltage and resistance readings may be taken and compared with those found on the schematic diagram supplied with this manual. NOTE: All voltage and resistance measurements were taken with a Heathkit Vacuum Tube Voltmeter. Voltage readings may vary  $\pm 10\%$  due to input voltage variations and tolerance of components. Reviewing the "Circuit Description" and "Block Diagrams" will prove helpful in isolating the source of difficulty.

The following chart was compiled to provide suggestions for the solution of service problems based on observed performance of the Receiver.

**CAUTION: REMOVE POWER FROM RECEIVER WHEN MAKING RESISTANCE MEASUREMENTS.**

CONDITION	POSSIBLE CAUSE	CORRECTION
Filaments and/or pilot lights fail to light.	1. Lack of filament voltage.	Check pin 5 of the power socket to the chassis to determine if filament voltage is present.
	2. Error in filament wiring.	Recheck filament wiring.
	3. Terminal strip Q wired wrong.	Recheck wiring of terminal strip Q.
	4. Switch on audio control open.	Replace control.
	5. Blown fuse.	Replace fuse after correcting the cause.

CONDITION	POSSIBLE CAUSE	CORRECTION
Some filaments and/or pilot lights operate-some do not.	1. Error in filament wiring	Recheck Step - By - Step for proper wiring, including connections to terminal strip Q.
	2. Short to ground of half of the filament line.	Check gray, black and brown filament leads for continuity. REMOVE TUBES AND PILOT LIGHTS.
Receiver dead, pilot lights and filaments lit.	1. No B+ for plate power.	Check pin 1 of power socket to determine if B+ is available.
	2. Shorts between socket terminals, leads and components.	Relocate to remove short for proper operation.
	3. High frequency oscillator failure.	Check wiring, resistances and voltages per schematic diagram of the 6EA8 mixer.
	4. Extreme misalignment.	Follow alignment procedure given under "Calibration and Alignment" section.
Hum.	1. Open grid circuit.	Recheck grid wiring.
	2. Heater to cathode leakage in a tube.	Replace tube.
Improper reception.	1. Misalignment.	Realign as covered previously.
Noise but no reception.	1. No antenna	Check connections.
	2. Band switch improperly wired.	Check all band switch wiring. <u>Remove B+.</u>
"S" Meter does not center to the left indication mark after Receiver is ON and warmed up.	1. Meter adjusting potentiometer miswired or not adjusted.	Check wiring. Adjust potentiometer arm until needle is on "O" S units.
	2. Low B+ voltage.	Increase to proper range of 300 volts.
	3. High B+ voltage.	Decrease to 300 V.
	4. Wrong value of resistance in plate circuit.	Check plate resistor of 6EA8 "S" meter amplifier.
	5. Open meter leads.	Check leads for continuity.

CONDITION	POSSIBLE CAUSE	CORRECTION
"S" Meter does not swing to indicate signal strength.	1. Meter adjusting potentiometer miswired or not adjusted.	Check wiring. Adjust potentiometer with no signal to "O" left.
	2. No AVC voltage.	Check AVC circuit wiring.
	3. Defective tube.	Check 6T8.
BFO inoperative.	1. Misalignment.	Align BFO to 3 mc (center of IF frequency) as covered in "Alignment" procedure.
	2. Bad tube.	Replace 6BE6.
	3. No B+ voltage.	Check wiring from OA2 voltage regulator.
	4. Error in wiring function switch.	Recheck wiring of function switch.
No sound - other functions normal.	1. Error in wiring first audio and power amplifier.	Check wiring from 6T8 through to 6AQ5. Check voltages in these stages.
	2. Error in wiring audio output transformer.	Check transformer wiring.
	3. Speaker voice coil open.	Replace.
Operates AM but not CW-SSB.	1. BFO failure.	Check wiring, resistance and voltages per schematic diagram of 6BE6 product detector.

If a signal generator or a signal tracer (such as the Heathkit Signal Tracer) is available, the signal may be traced from the speaker back, one stage at a time, to the antenna. Where the signal stops (no longer can be heard) is undoubtedly the stage in which the difficulty lies and all details may be isolated and checked at that point.

#### ACCESSORY EQUIPMENT

Although not primarily designed for mobile operation there are several pieces of Heathkit equipment which have proven to be very valuable accessories.

**MARINE BATTERY CHARGE INDICATOR:** This unit, which is made for use on either 6 or 12 volt systems, continuously monitors the condition of battery charge. By always being aware of battery condition, the mobileer is less likely to walk home, also, when an external charging source is used to permit parked operation, the required amount of external power is instantly apparent on the charge indicator meter.

**MARINE CONVERTER KIT:** This is a heavy duty charging source operated by 115 VAC, and providing up to 20 amperes at 6 volts, and 10 amperes at 12 volts. As such, it may be used to keep the battery charged while operating when the car is parked, without running the motor. Such conditions normally prevail while making antenna adjustments, or while using the mobile as a temporary fixed station.

**MOBILE TUNING METER:** This kit measures relative RF field strength. It may be mounted on the car dash and will indicate correct transmitter tuning by maximum antenna radiation. This unit was designed for mobile applications and requires no external power source.

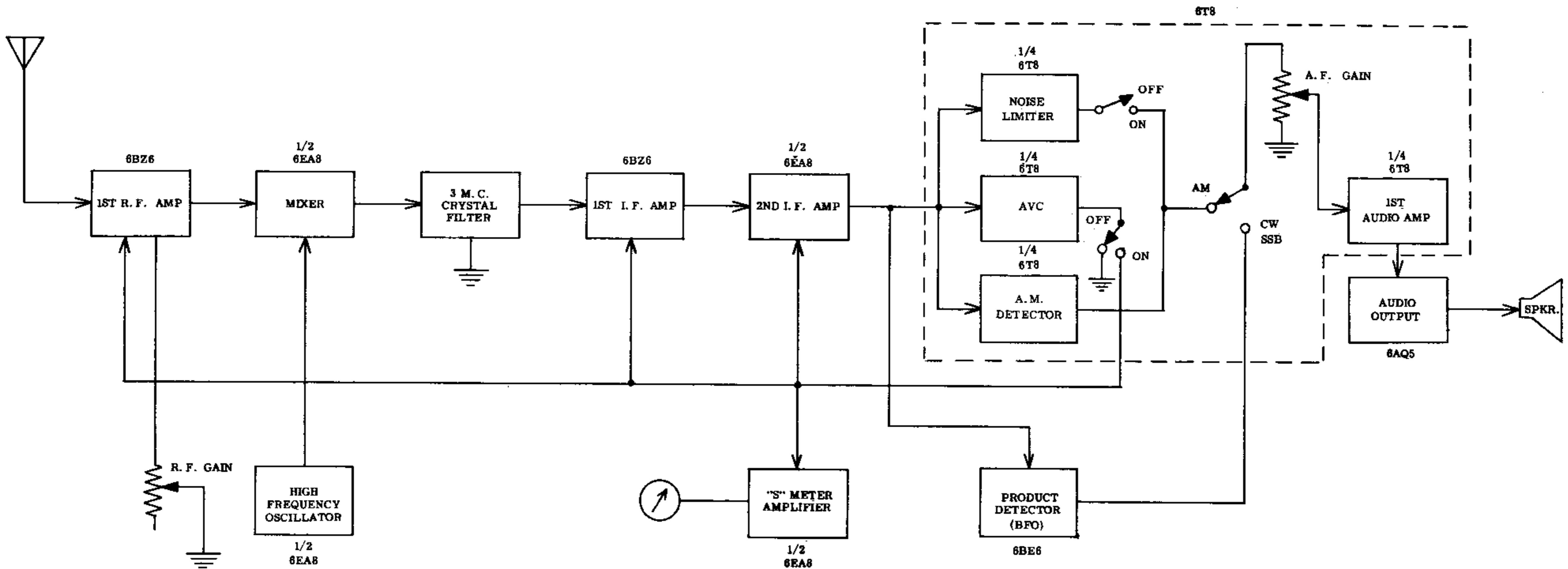

BLOCK DIAGRAM

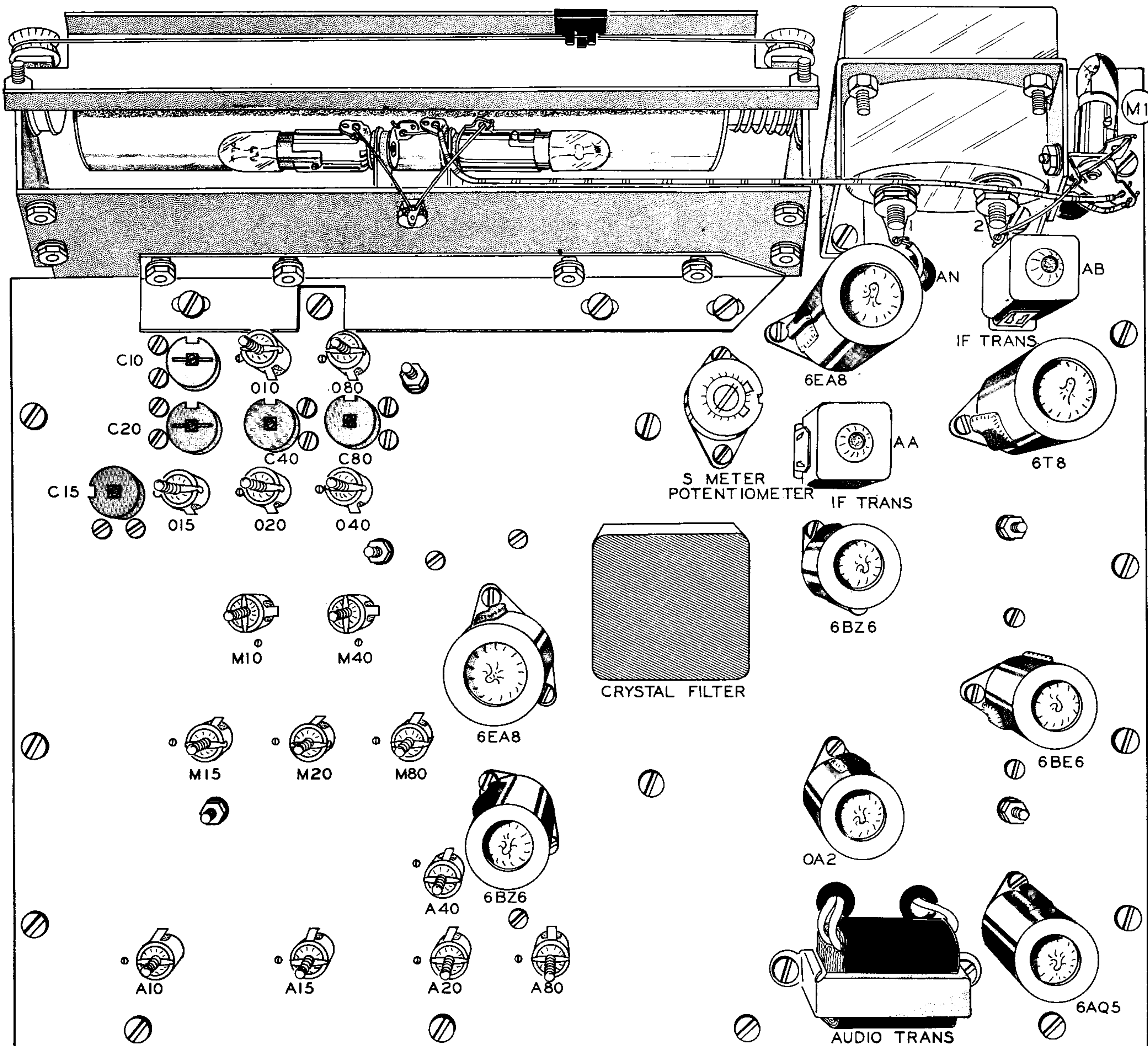
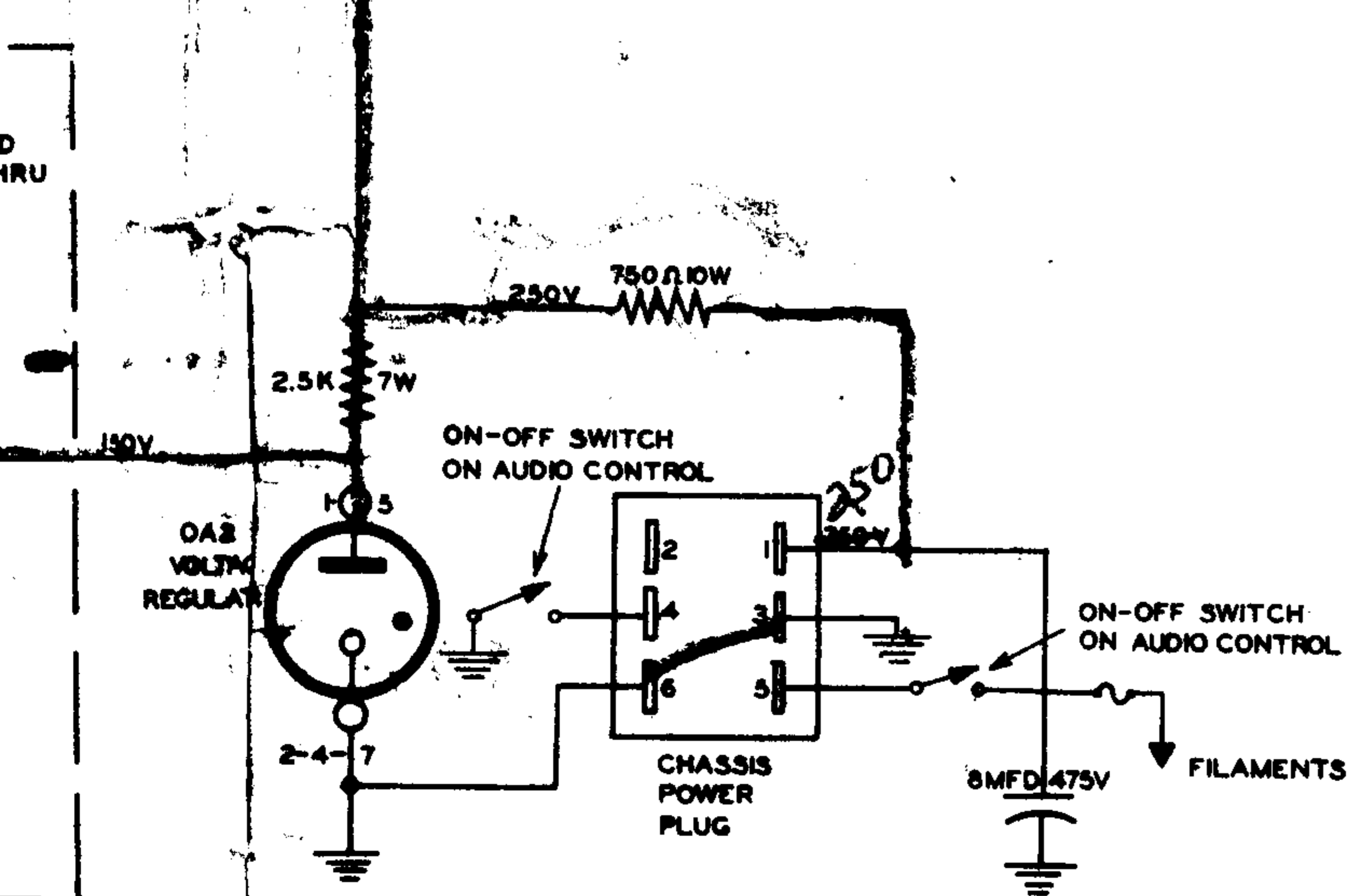
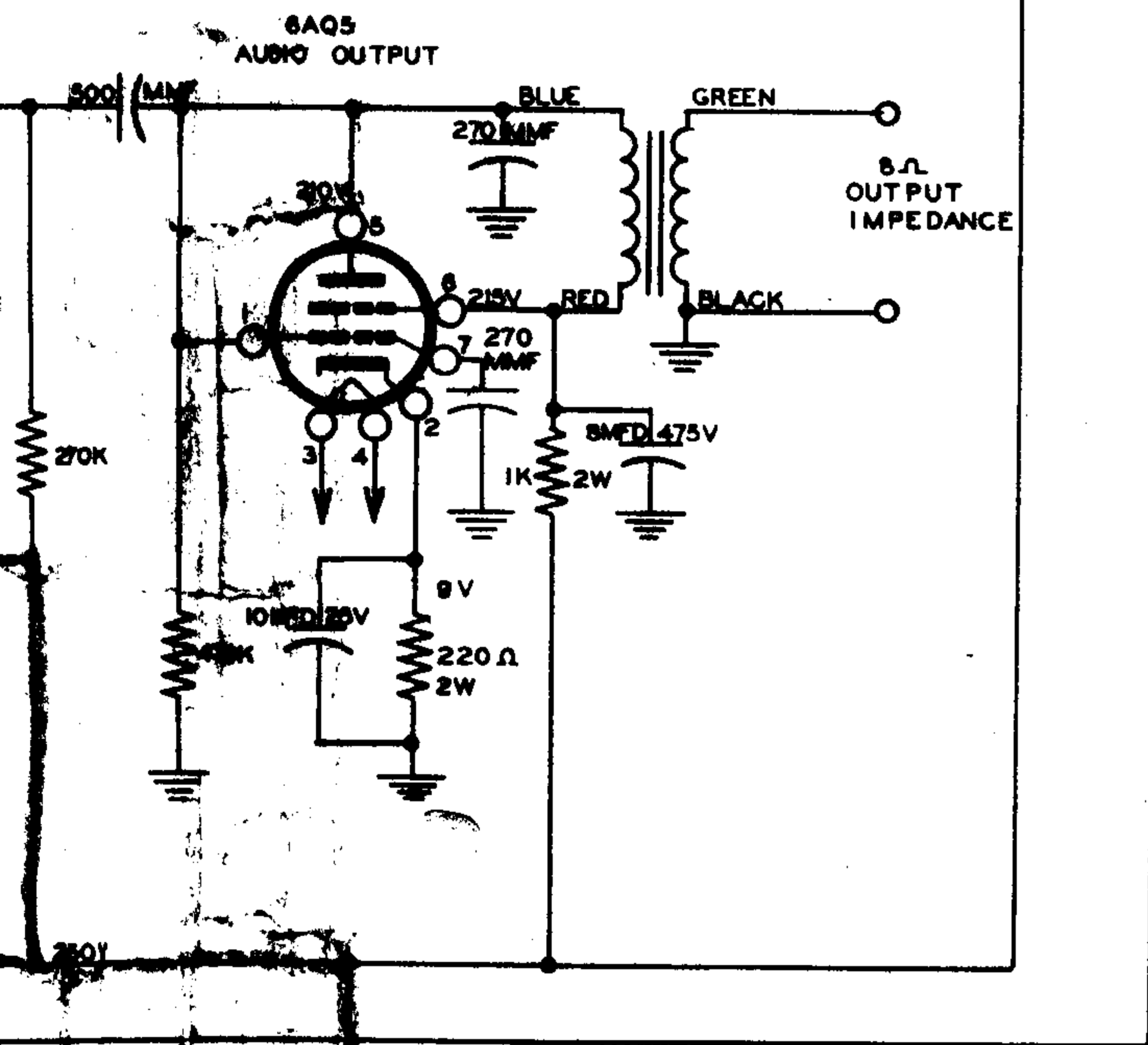
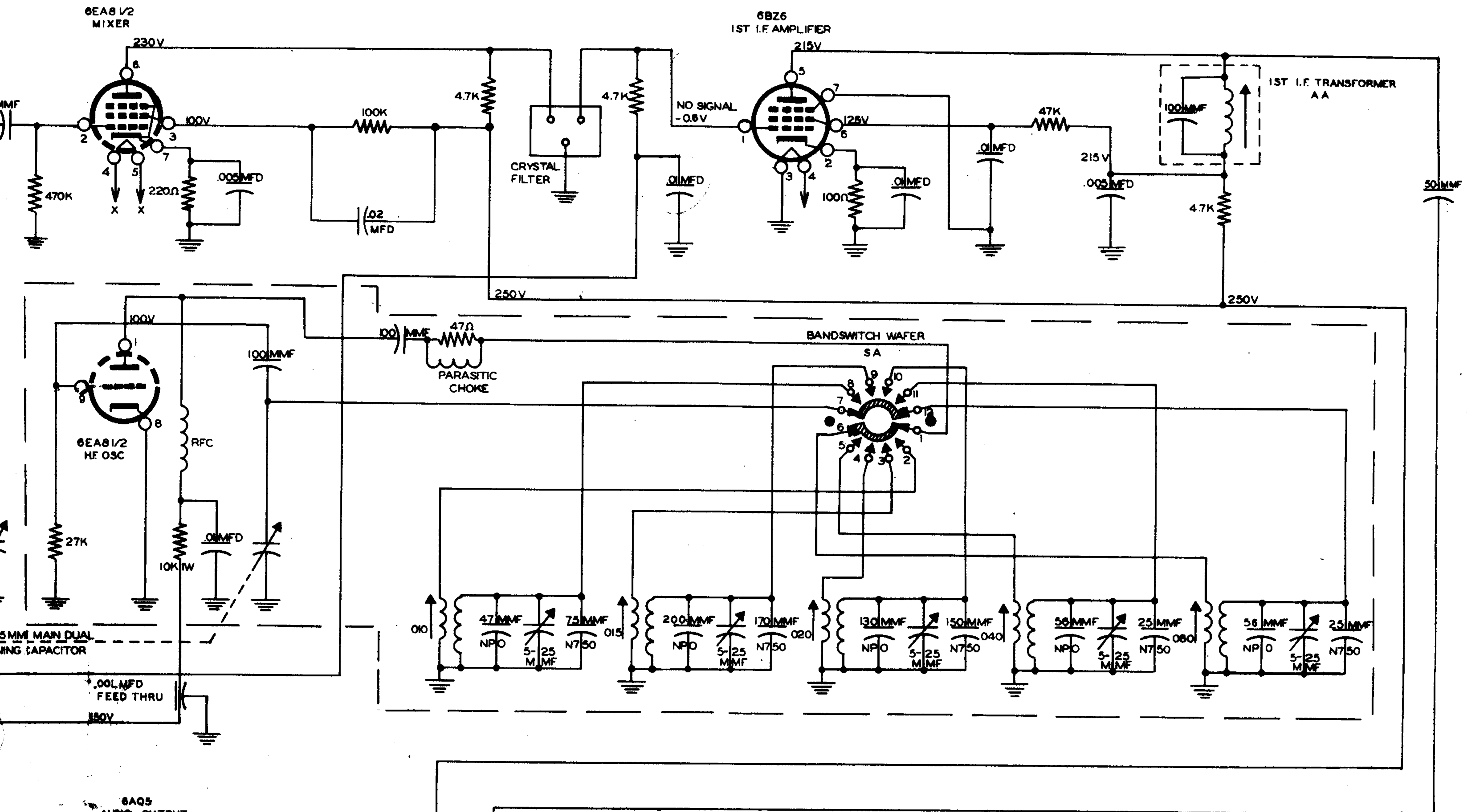

Figure 30



**GENERAL INFORMATION:**

BANDSWITCH WAFERS ARE SHOWN IN 80 METER POSITION.  
 FUNCTION SWITCH IS SHOWN IN AM POSITION.  
 AVC SWITCH IS SHOWN IN OFF POSITION.  
 NOISE LIMITER SWITCH IS SHOWN IN OFF POSITION.

**TROUBLESHOOTING INFORMATION:**

ALL MEASUREMENTS MADE USING A HEATHKIT MODEL V-7A VACUUM TUBE VOLTMETER.  
 10% VARIATION IN READINGS SHOULD BE ALLOWED FOR DIFFERENCES IN METER CALIBRATION.

VOLTAGES SHOWN ARE BASED ON USING THE MP-1 TRANSISTOR POWER SUPPLY.

BATTERY TERMINAL POTENTIAL IS 12.6 VOLTS-VARIATIONS WILL CAUSE CORRESPONDING DIFFERENCES IN READINGS.

ALL VOLTAGES ARE BASED ON "NO SIGNAL" CONDITIONS, WITH R. F. GAIN SET AT MAXIMUM.

THE FOLLOWING OSCILLATOR GRID VOLTAGES ARE MADE WITH AN RF PROBE AT OSCILLATOR PIN 8.

- 80 METERS - 5 V
- 40 METERS - 2 V
- 20 METERS - 6 V
- 15 METERS - 3.5 V
- 10 METERS - 3 V

WIRING SHOWN IS FOR NEGATIVE GROUND VEHICLES.

FOR POSITIVE GROUND VEHICLES SEE MODIFICATION SHEET ENCLOSED BEFORE COMPLETING WIRING OF CHASSIS POWER PLUG.

**PRODUCT DET.**

