

PRICE \$1.00

RECEIVED MAY 28 1951

# HEATHKIT<sup>®</sup> ASSEMBLY MANUAL

HEATH COMPANY NEWTON, MASS.

HEATH COMPANY

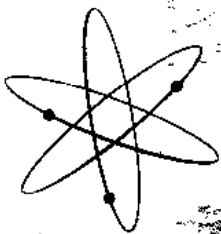
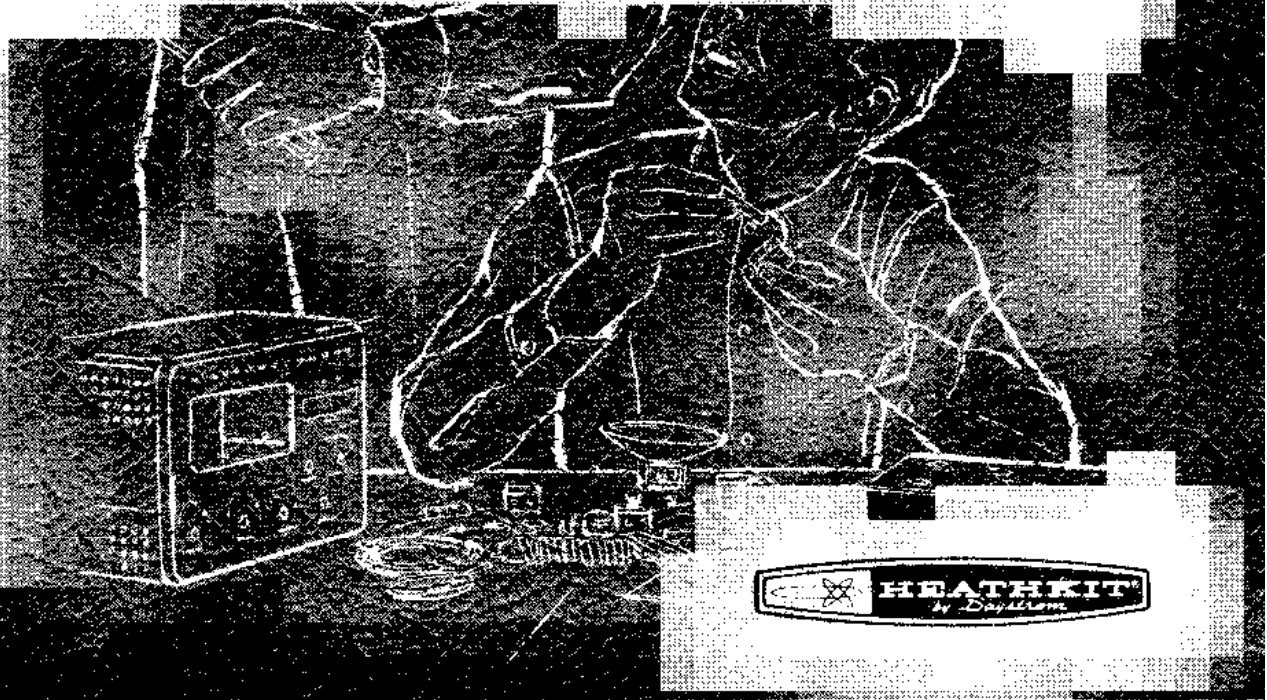

## Q MULTIPLIER

MODEL QF-1

# ASSEMBLY AND OPERATION OF THE HEATHKIT Q MULTIPLIER MODEL QF-1

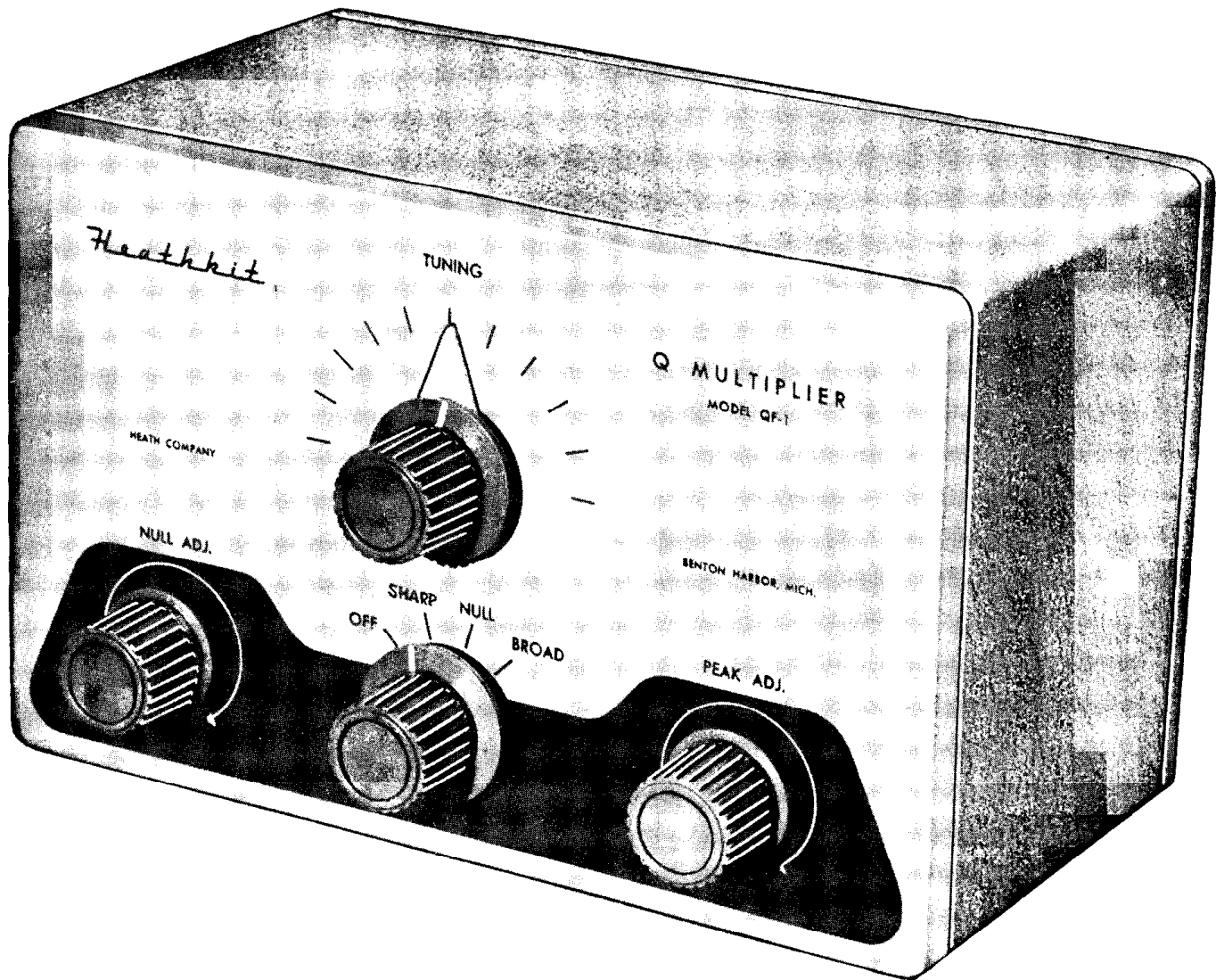

## SPECIFICATIONS

Operating Frequency.....	450-460 kc
Operation.....	OFF - SHARP PEAK - NULL - BROAD PEAK
Tube Complement.....	12AX7 multiplier
Power Requirements.....	6.3 volts AC 300 ma, 150-250 volts DC 2 ma
Cabinet Size.....	7 3/8" wide x 4 11/16" high x 4 1/8" deep
Net Weight.....	1 1/2 lbs.
Shipping Weight.....	.3 lbs.

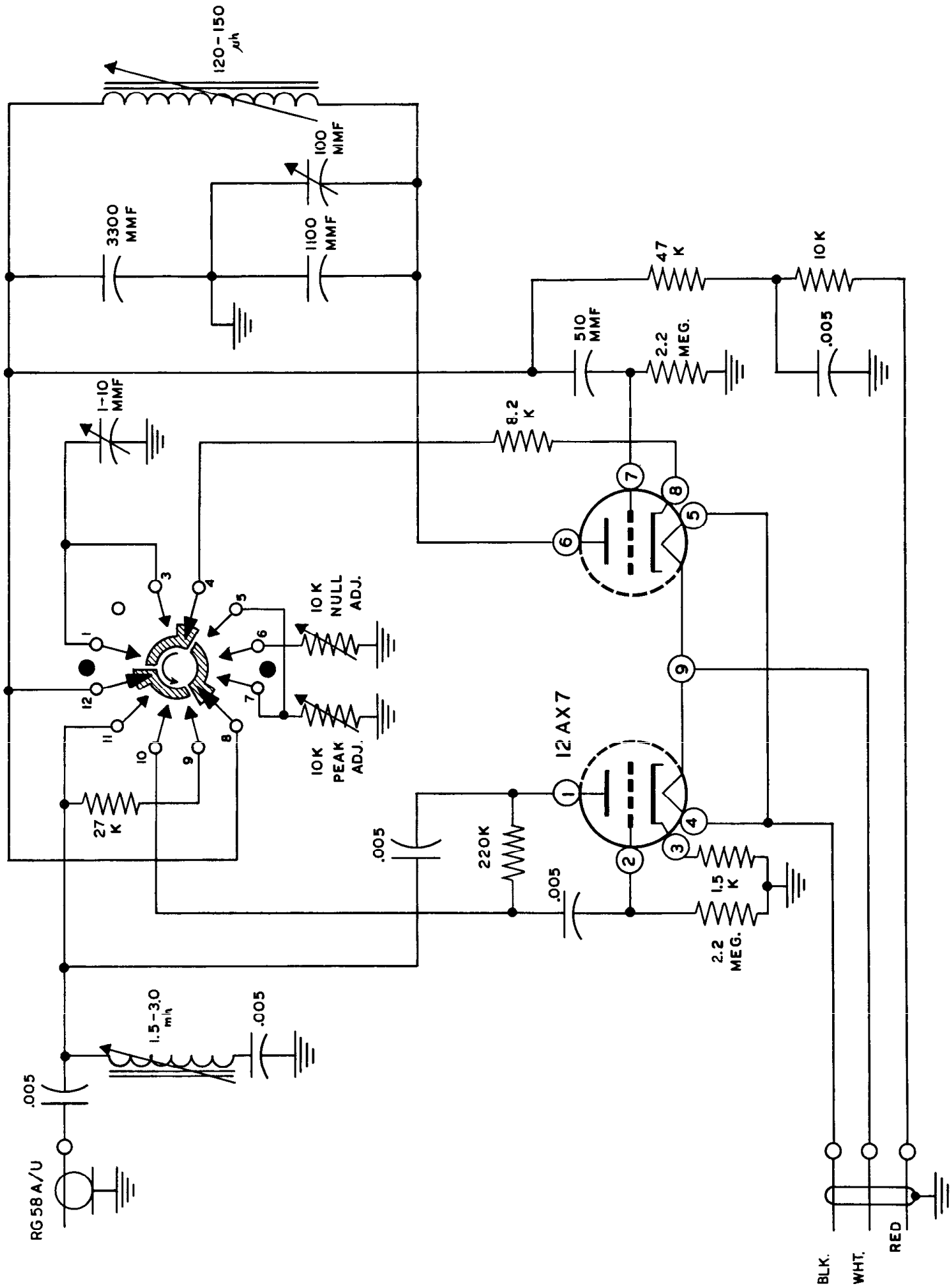

SCHEMATIC OF Q MULTIPLIER QF-1

## INTRODUCTION

The Heathkit model QF-1 Q Multiplier when used with a communications receiver, provides additional selectivity or signal rejection as desired. Because the peak or null effect of the Q Multiplier may be tuned across the receiver's IF bandpass, its operation is more flexible than that of a crystal filter. The Q Multiplier may be used with a receiver which already has a crystal filter to obtain two simultaneous functions. For example, the receiver's crystal filter could be set to peak the desired signal and the Q Multiplier used to null an adjacent signal.

The QF-1 requires very little power in either filament AC or B+, consequently, it can derive its power from any receiver without overloading the receiver power supply. When properly connected and adjusted, it will not decrease the receiver sensitivity and may even increase it. In peak position, an audible gain will be noted on CW signals; on phone signals a carrier gain will be noted on the S meter. However, the audio will be down slightly due to narrowing of the transmitted sidebands.

The reduced sideband reception will tend to attenuate the higher audio frequencies. This is more than compensated for by the increased readability against the surrounding QRM.

### CIRCUIT DESCRIPTION

The Q Multiplier functions as a very high Q circuit coupled in parallel across the IF transformer for peak or by inversion through another triode tube section, in series for null. Any high Q circuit tends to have a very sharp point of resonance as either a series or parallel tuned circuit.

As the Q of the circuit is increased, the side slope of the resonant peak or dip becomes steeper. A parallel circuit has a very high impedance at resonance and a series circuit a very low impedance, consequently when circuits of this type are connected in shunt across the receiver IF circuit, the following action takes place. As a parallel circuit, any signal passing through the IF at the resonant frequency of the Q Multiplier sees a very high shunt impedance and is not attenuated, whereas signals slightly off the resonant frequency fall along the slope or "skirt" of the Q Multiplier bandpass and seeing a relatively low impedance, are shunted to ground. See Figure 1. By means of the variable capacitor in the QF-1, this peak can be tuned to any place in the IF bandpass to peak one signal and attenuate all others.

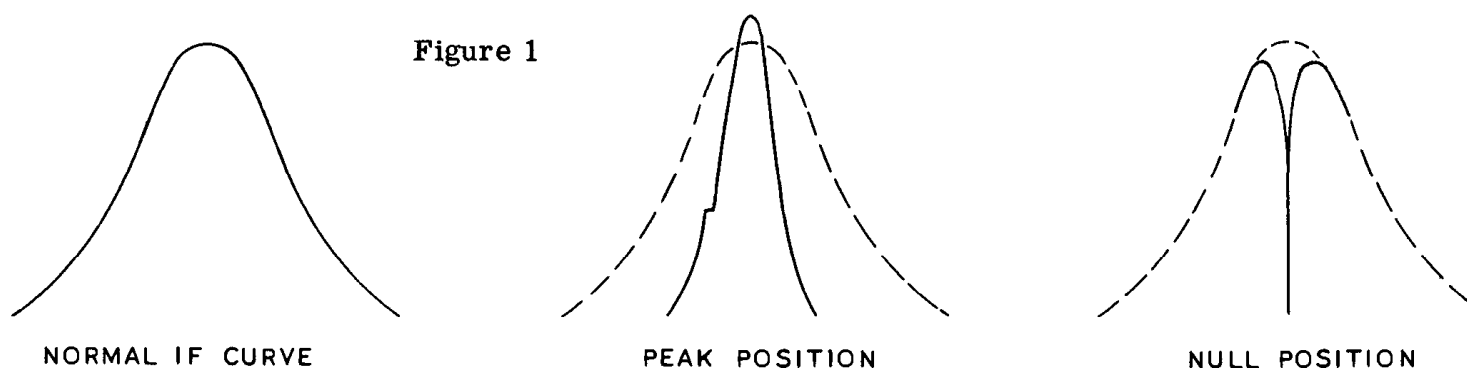

In the null position, any signal passing at the series resonant frequency of the Q Multiplier sees a very low impedance to ground and is rejected at this point. The series resonance can also be moved across the IF pass band, consequently a heterodyne adjacent to the desired signal can be dropped into the notch and eliminated.

Basically, the Q multiplier bears a resemblance to the old regenerative IF but is capable of higher Q and is more versatile. The circuit is centered around a coil having a Q of 200 or more (#40-68) and this coil's Q amplified by positive feedback in one triode section of the 12AX7 tube to an apparent Q of approximately 4000. This compares very favorably with the Q of the quartz crystal used in crystal filters. The other triode section of the 12AX7 tube is switched in as a negative feedback circuit to form the null circuit. The remaining coil (#40-67) is used to tune out the capacity of the coaxial cable connecting the Q Multiplier to the receiver IF stage. This is necessary to prevent detuning the receiver IF by the cable capacity.

- ( ) Place a small pointer knob over the outer shaft of the tuning capacitor. Align the white index with the pointer and tighten the set screw. Be sure the knob and pointer do not bind together.
- ( ) Turn the switch shaft counterclockwise and install the other pointer knob with the index at the OFF position.
- ( ) Install the two round knobs on the peak and null adjust controls. No positioning is necessary here.
- ( ) Insert the 12AX7 tube in the 9-pin socket.

This completes the assembly and wiring of the Q multiplier.

#### CONNECTION TO THE RECEIVER

The QF-1 derives its power from the receiver it is used with, so some provision must be made for this supply. There is no way for the Heath Company to anticipate what type of receiver will be used with the QF-1. However, an octal socket and plug are furnished to aid in making the power connection. Some receivers are furnished with an auxiliary power socket which is usually of the octal type. If this is true in your case, check the receiver schematic to ascertain which contacts provide plate, filament and ground connection and wire the QF-1 3-wire cable to the octal plug in accordance with these. If the receiver has no power outlet, you may mount the octal socket furnished on the receiver and make the appropriate internal connections for power. The 3-wire cable may be wired directly into the receiver, however the former arrangement is more convenient. By the same token, a phono plug and jack are furnished to connect the coaxial cable to the receiver IF stage.

The Model QF-1 can be used with receivers having either a 6 or 12 volt filament supply. If the QF-1 is to be used with a receiver which has a 6 volt filament supply, the filament circuit should be wired as shown in Pictorial 1 on Page 7 of the construction manual. However, if the unit is to be used with a receiver having a 12 volt supply, the filament circuit should be wired in the following manner: One lead should be connected from terminal B4 to pin 4 on the tube socket. The other lead should be connected from terminal B3 to pin 5 of the tube socket. Pins 4 and 5 should not be connected together. Pin 9 will then be left open.

In connecting the 3-wire power cable, the outside shield braid goes to ground, the red wire to B+ 150-250 volts, and the white and black wires to the filament connections. If the receiver has one side of the filament circuit grounded, either the white or black wire should also be grounded.

The QF-1 Q Multiplier kit requires between 150 and 250 volts DC for its plate power. We do not recommend exceeding these figures.

#### CONNECTION FOR USE WITH AR-3 RECEIVER

1. Wire filament for 12 V in QF-1 as stated in the manual.
2. Connect red wire to pin 3 of the plug.
3. The other two wires in the cable are filaments. Select either wire as ground and connect it and the shield to pin 1 of plug.
4. The other wire is connected to pin 8.

In regard to the coaxial cable connection, the outside shield is connected to ground and the inner conductor connected to either the plate side of the input IF transformer or the plate connection of the mixer tube at the socket. This connection should be as short as possible and isolated from other receiver circuits. If the phono jack is mounted on the rear of the receiver, be sure to mount it at a point close to the mixer plate circuit. Shielded lead may be used to connect the phono jack to the IF circuit, in which case the first IF primary should be retuned to compensate for the short shielded lead. Do this before the QF-1 is attached to the receiver.

## ALIGNMENT

For best results, the receiver IF strip should be in good alignment at 455 kc. It would pay to check the receiver alignment before proceeding.

At this point, connect the QF-1 Q Multiplier kit to the receiver. Then, with the selector switch on the QF-1 in the OFF position, tune in a steady phone signal or possibly a broadcast station. Be sure that the signal is centered in the IF band-pass. This can be noted by the greatest S meter reading, maximum audio signal, or by maximum AVC voltage in the receiver. If the receiver, to which the unit is to be connected, does not contain an S meter, it is recommended that a voltmeter be connected between the AVC line in the receiver and ground. This meter should then be placed in a negative DC position and will then act similarly to an S meter. For best results, this meter should have a negative DC range low enough to permit at least a center scale deflection of the meter when the receiver is tuned to a station.

After the above step has been completed, you are ready to align the Model QF-1. First of all, tune the 40-67 coil which is near the top of the QF-1 chassis for the highest S meter reading, loudest signal, or a maximum negative DC reading on the meter mentioned previously (refer to Figure 7). When adjusting this coil, you will notice two different points at which a peak can be obtained; however, one of these points will be with the adjustment slug protruding from the bottom of the coil; therefore, this peak should not be used. The peak which is obtained with the coil slug midway in the coil should be used. This adjustment tunes out the reactance of the coaxial cable and will not have to be changed again.

The next adjustment to be made is a critical adjustment, therefore, it is recommended that this procedure be followed explicitly. Rotate the null and peak adjust controls to the midpoint of their rotation, then revolve the tuning condenser adjustment knob until the plates of the tuning condenser are 50% meshed. Then, rotate the selector switch to the null position and adjust the 40-68 coil which is the coil next to the chassis bottom, for a null on the S meter, minimum signal, or at the least amount of negative DC voltage on the previously mentioned meter. This dip or null will be extremely sharp. With an IF frequency of 455 kc, this null will be found with the null adjusting screw between 1/8" and 1/4" above the coil mounting frame. You might rock back and forth over this point several times to make sure that the maximum null reading is obtained.

At this point, without changing any of the adjustments on either the receiver or the QF-1, change the selector switch on the QF-1 to the peak position and adjust the 1 to 10  $\mu\mu\text{f}$  capacitor for maximum S meter reading or maximum negative DC voltage on the meter. Normally, the adjustment of this trimmer will have very little effect on the actual point of peak. Therefore, if you are unable to obtain a satisfactory peak, it is suggested that you redress the lead between pin 11 of the selector switch and pin 1 of the input coil. This should be dressed either closer or farther from the chassis, depending upon whether an increase or decrease in capacity is required. For best results, the null and peak should be at exactly the same point or dial setting of the QF-1.

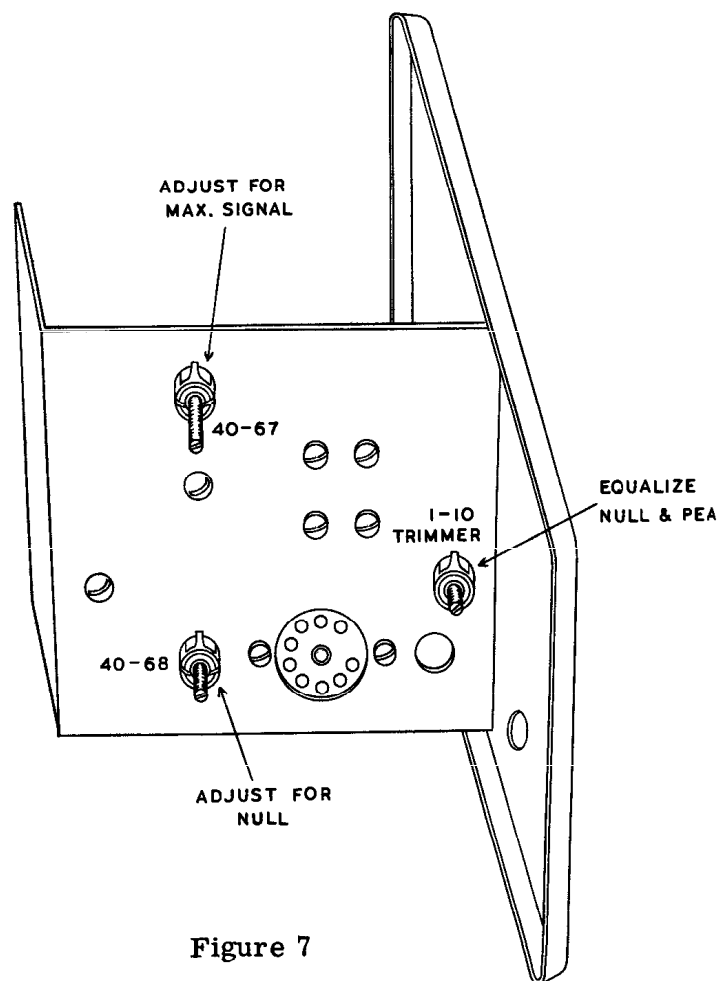

Figure 7

Before installing the QF-1 in the cabinet, experiment with other stations or signals on different frequencies, both as a preliminary familiarization and as a double check on the Q multiplier alignment.

Install rubber feet in the four 1/4" cabinet holes and slide the QF-1 into the cabinet with the cords passing through the large hole in the rear. Secure the instrument to the cabinet with two #6 sheet metal screws through the rear cabinet holes.

## OPERATION

The Q Multiplier is a resonant circuit tuned to the IF of the receiver. It is so arranged that signals slightly removed from the IF will be bypassed to ground. Misalignment will give the effect of deadening the receiver. Actually, due to its regenerative characteristic, it will amplify the desired signal and deaden adjacent unwanted signals.

The Q Multiplier is extremely sensitive to tune and the operator will find that it may take two or three weeks before he becomes proficient in its operation. Proper tuning is of the utmost importance. The Q Multiplier will appear to greatly amplify the sensitivity of the receiver.

As the external core type of coils used with the QF-1 provide their own shielding, the previous alignment will not be affected by the cabinet. Consequently, after reconnecting the QF-1 to the receiver, it is ready for operation.

**OFF position:** In this position, the QF-1 has no effect upon the receiver and it will operate in the usual manner.

**SHARP PEAK:** By varying the PEAK ADJ. control, the receiver selectivity can be changed from broad to extremely sharp. With the control counterclockwise, the bandpass will be quite broad and the receiver gain somewhat decreased. As the control is rotated clockwise, the peak becomes narrower and the gain higher until the sharpest point is reached at just below the point of oscillation. Phone signals may lose some volume due to loss of high frequency response.

With the Q multiplier peaked, the tuning may be varied to accentuate any signal within the receiver IF bandpass and attenuate all others. This is the main advantage the Q multiplier has over a crystal filter. As the receiver does not have to be tuned to peak any particular signal within its bandpass, there is little danger in losing the desired signal.

**NULL:** The NULL position is particularly good for removing heterodynes on phone signals or adjacent CW signals. It is extremely sharp and as such, is very critical to tune. It probably will require a great deal of practice before this function of the Q multiplier can be used to advantage. Besides nulling the interfering signal, it is equally easy to remove the desired signal. Until you become proficient in the operation of the QF-1, the latter effect probably will occur most often.

It may help to remember that the QF-1 tunes toward the high end of the IF bandpass in a clockwise direction, providing the receiver local oscillator is higher in frequency than the incoming signal. Based upon the above premise, a heterodyne higher in frequency than the desired signal would be removed by approaching it in a counterclockwise direction and vice versa. When the undesired signal has been placed in the notch, adjust both the tuning and null adjust controls for maximum null.

**BROAD PEAK:** This position allows a higher gain than the SHARP PEAK when a wider bandpass is desired. It also allows the Q multiplier to be used as a BFO by advancing the peak adjust control to just past the oscillation point.

## IN CASE OF DIFFICULTY

Mistakes in wiring or poorly soldered connections are the most common cause of difficulty. Consequently, the first step is to recheck all wiring against the pictorial and schematic diagram. Often having a friend check the wiring will locate an error consistently overlooked.

With miniature sockets, there is a possibility of shorts between adjacent socket terminals due to the close spacing. This should be checked and if any doubt exists, the terminals should be pried apart until obvious spacing can be seen between them.

There is also the possibility of the coils being open, caused by damage to the wire at the terminals. This may be checked with an ohmmeter **WITH ALL VOLTAGES OFF**. Resistors may have been damaged due to excess heat. These also may be checked with an ohmmeter.

Check the tuning capacitor to see that the plates do not short in any position.

	Pin 1	Pin 2	Pin 3	Pin 4	Pin 5	Pin 6	Pin 7	Pin 8	Pin 9
PEAK	0	0	0	6.3AC	6.3AC	240	0	2.7	0
NULL	100+	-1	.7	6.3AC	6.3AC	210	0	2.5	0

Typical tube socket voltage readings taken with a vacuum tube voltmeter and using a 250 volt supply with one side of the filament grounded.

## REPLACEMENTS

Material supplied with Heathkits has been carefully selected to meet design requirements and ordinarily will fulfill its function without difficulty. Occasionally improper instrument operation can be traced to a faulty tube or component. Should inspection reveal the necessity for replacement, write to the Heath Company and supply all of the following information:

- A. Thoroughly identify the part in question by using the part number and description found in the manual parts list.
- B. Identify the type and model number of kit in which it is used.
- C. Mention date of purchase.
- D. Describe the nature of defect or reason for requesting replacement.

The Heath Company will promptly supply the necessary replacement. Please do not return the original component until specifically requested to do so. Do not dismantle the component in question as this will void the guarantee. If tubes are to be returned, pack them carefully in prevent breakage in shipment as broken tubes are not eligible for replacement. This replacement policy does not cover the free replacement of parts that may have been broken or damaged through carelessness on the part of the kit builder.

## SERVICE

In the event continued operational difficulties of the completed instrument are experienced, the facilities of the Heath Company Service Department are at your disposal. Your instrument may be returned for inspection and repair. Due to the simplicity of this kit, no minimum service fee has been fixed; the charges will be determined by the amount of time needed to service the QF-1, plus the price of any additional parts or material required. However, if the completed kit is returned within the Warranty period, parts charges will be governed by the terms of the Warranty. State the date of purchase, if possible. **THIS SERVICE POLICY APPLIES ONLY TO COMPLETED INSTRUMENTS CONSTRUCTED IN ACCORDANCE WITH THE INSTRUCTIONS AS STATED IN THE MANUAL.** Instruments that are not entirely completed or instruments that are modified in design will not be accepted for repair. Instruments showing evidence of acid core solder or paste fluxes will be returned not repaired.