

PRICE 15/-



Assembling  
and  
Using Your...



**BASIC AMATEUR  
RECEIVER**

**MODEL RA-1**

**DAYSTROM LIMITED**

A Subsidiary of the Daystrom Group,  
Manufacturers of the world's finest  
Electronic Equipment in Kit Form.

**GLOUCESTER, ENGLAND**

Partial manual for British Heathkit 160-10m Hamband receiver.  
Compliments of Dave Gordon-Smith, G3UUR.

This partial copy of the Assembly and Operating Manual for the RA-1 contains the specification, circuit diagram, operating instructions and those parts of the assembly instructions which are relevant to alignment and restoring an RA-1.

Daystrom Ltd, the UK subsidiary of the Heath Company, introduced the RA-1 as an entry-level ham bands receiver in 1963. It has been suggested that the RA-1 is merely a copy of the American Heathkit HR-10. This is simply not true, as a glimpse at the circuit and valve (tube) line-up will show. The front end module of the RA-1 was made by Electroniques of Felixstowe, a well-known company to British home-constructors in the 1960s. The module made for Daystrom Ltd was slightly different to the standard Electroniques ham band front end, in that it has the bands wired in reverse on the bandswitch.

The mains transformer of the RA-1 has taps for 100-125V, as well as 200-250V, as it was intended to sell this receiver anywhere in what remained of the British Empire, where many different mains voltages could be found at either 50 or 60 c/s.

Some modifications have been hand-written over the type-written figures in the Handbook. On Page 3 in the RESISTOR AND CAPACITOR IDENTIFICATION CHART the value of R3 has 270 ohms written over the original value of 1k. On Page 28 the value of R35 mentioned in the note on BFO injection has been altered to 270k - 560k from the original 150k - 270k.

DG-S.

# Assembly and Operation of the Heathkit Basic Amateur Receiver

## MODEL RA-1



### SPECIFICATION

Frequency Coverage:	
160 metre Band .....	1.7 to 2.0 Mc/s
80 metre Band .....	3.5 to 4.0 Mc/s
40 metre Band .....	7.0 to 7.3 Mc/s
20 metre Band .....	14.0 to 14.45 Mc/s
15 metre Band .....	21.0 to 21.5 Mc/s
10 metre Band .....	28.0 to 30.0 Mc/s
Intermediate Frequency: .....	1621 Kc/s ( $\frac{1}{2}$ lattice filter)
Sensitivity: .....	2 microvolts for 10 dB S/N ratio or better
Image Rejection: .....	40 dB or better
Input Impedance: .....	75 $\Omega$ co-axial or terminal
Audio Output Impedance: .....	3 $\Omega$ (speaker), 600 $\Omega$ (phones)
Audio Output: .....	2 watts (for 8 $\mu$ V signal)
Panel Controls: .....	AF GAIN incorporating AC on-OFF
	RF GAIN
	MAIN tuning
	BAND switch
	BFO ON-off
	AVC on-OFF
	USB, O, LSB MODE switch
	CALibrate press-on switch
	CALibrate ADJust
	ANTenna TRIMmer
	NL MIN - max
Valve and Diode Complement: .....	EF183 RF amplifier, ECH81 Mixer oscillator,
	EF183 1st IF amplifier, ECP82 2nd IF amplifier - BFO,
	OA81 Detector, OA81 AVC, EB91 Noise limiter,
	ECL86 1st audio - audio output, EZ81 Rectifier,
	OA2 Stabiliser

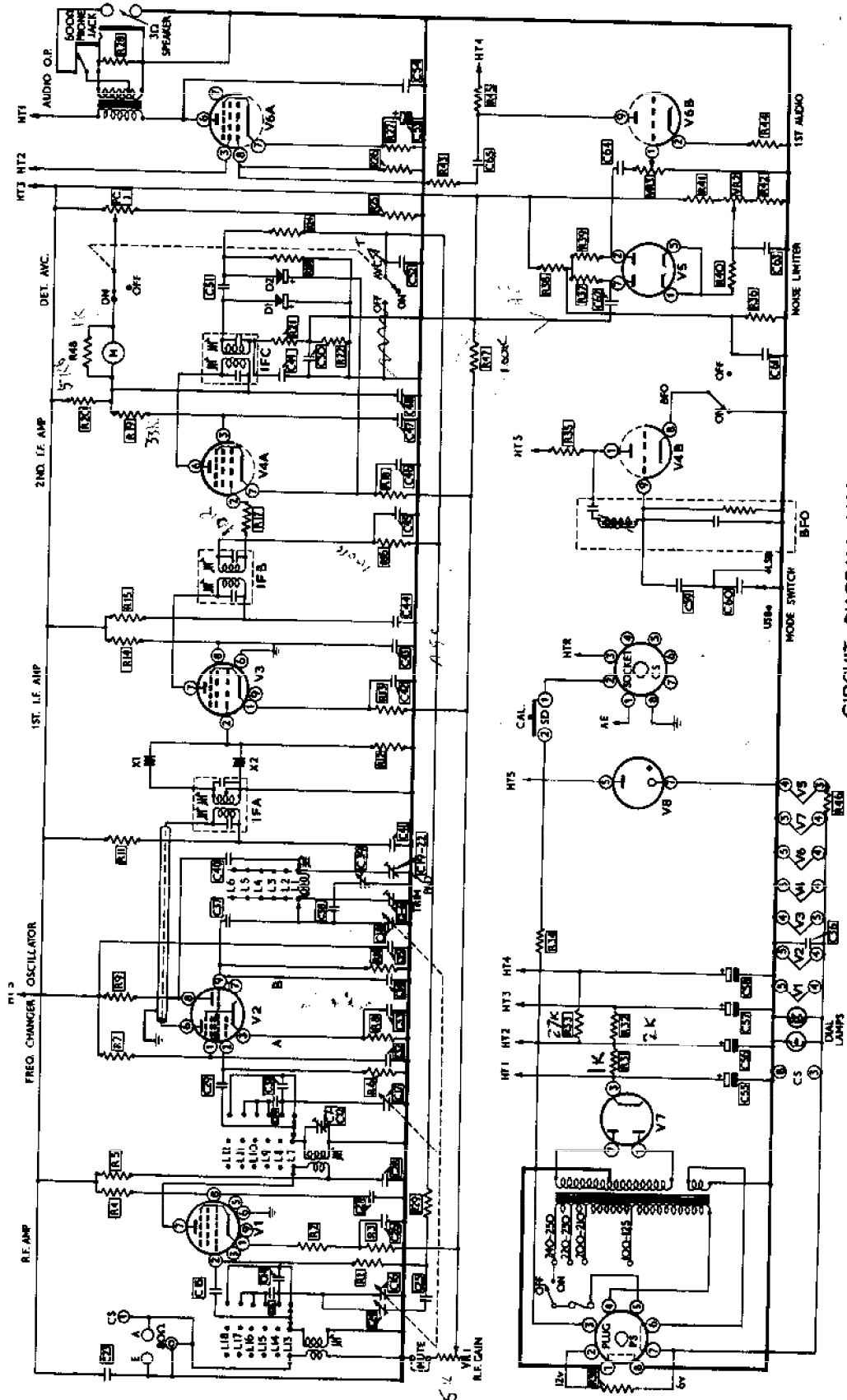

CIRCUIT DIAGRAM, MODEL RA-1

*Handwritten note:* 100K R.F. GAIN

*Handwritten note:* 100K R.F. GAIN

Power Requirements: .....	110-240v AC, 50/60 c/s, 50 watts
For Mobile or Portable Use .....	LT:- 6 or 12v at 3.5 A
	HT:- 250v at 65 mA
Auxiliary Supplies Available: .....	LT:- 6.3v AC at 1 A
	HT:- 250v DC at 25 mA
Cabinet Size: .....	13 $\frac{3}{4}$ " wide x 11 $\frac{1}{2}$ " deep x 6 $\frac{1}{2}$ " high
Net Weight: .....	18 lbs.
Shipping Weight: .....	21 lbs.
General: .....	'S' meter zero adjust
	Muting via RF and IF stages
	Standby via power transformer secondary centre tap return
	Phone jack on front panel
Optional Extras: .....	100 Kc crystal calibrator
	Matching loudspeaker in metal cabinet

### INTRODUCTION

The Heathkit Model RA-1 Basic Amateur Bands Receiver is designed for flexible use as a high performance economical fixed station, portable or mobile receiver.

Frequency coverage of the Receiver is limited for use on the amateur bands 160 to 10 metres. Each band is separately calibrated on a large easy-to-read slide rule scale. The dial is illuminated and provides approximately 5" of band-spread for each band. A slow motion drive is incorporated, that whilst permitting fast traversing of the bands, allows a small section to be tuned at a very slow rate.

The Receiver features a signal strength 'S' meter, a front panel dial calibration control that operates in conjunction with provisions made for a 100 Kc/s calibrator, a tuned RF amplifier stage, a half lattice filter, adjustable noise limiter, plus many other features desirable on an amateur receiver. Provision has been made for 'Q' Multiplier input.

The low-silhouette styling and the green-grey colour combination will prove an attractive addition to any surroundings.

#### RESISTOR AND CAPACITOR IDENTIFICATION CHART (see Circuit Diagram)

C1 .. 4-20 pF	C21 .. 5-25 pF	C41 .. .005 $\mu$ F	C61 .. .25 $\mu$ F	R15 .. 1K	R35 .. 220K
C2 .. 4-20 pF	C22 .. 5-25 pF	C42 .. .1 $\mu$ F	C62 .. .005 $\mu$ F	R16 .. 100K	R36 .. 220K
C3 .. 10-60 pF	C23 .. .01 $\mu$ F	C43 .. .005 $\mu$ F	C63 .. .005 $\mu$ F	R17 .. 10 $\Omega$	R37 .. 100K
C4 .. 6-25 pF	C24 .. 20.5 pF	C44 .. .005 $\mu$ F	C64 .. .005 $\mu$ F	R18 .. 470 $\Omega$	R38 .. 220K
C5 .. 4-20 pF	C25 .. .01 $\mu$ F	C45 .. .005 $\mu$ F	C65 .. .005 $\mu$ F	R19 .. 33K	R39 .. 220K
C6 .. 4-20 pF	C26 .. .01 $\mu$ F	C46 .. .1 $\mu$ F		R20 .. 5.6K	R40 .. 100K
C7 .. 6-25 pF	C27 .. .01 $\mu$ F	C47 .. .005 $\mu$ F	R1 .. 220K	R21 .. 47K	R41 .. 47K
C8 .. 6-25 pF	C28 .. .01 $\mu$ F	C48 .. .005 $\mu$ F	R2 .. 27 $\Omega$	R22 .. 22K	R42 .. 47K
C9 .. 6-25 pF	C29 .. 100 pF	C49 .. 200 pF	R3 .. 270 $\Omega$	R23 .. 2.2M	R43 .. 47K
C10 .. 6-25 pF	C30 .. 15 pF	C50 .. 200 pF	R4 .. 33K	R24 .. 1M	R44 .. 2.2K
C11 .. 6-25 pF	C31 .. 87 pF	C51 .. 15 pF	R5 .. 2.2K	R25 .. 5K	R45 .. 220K
C12 .. 6-25 pF	C32 .. .01 $\mu$ F	C52 .. .01 $\mu$ F	R6 .. 220K	R26 .. 560K	R46 .. 10 $\Omega$
C13 .. 15 pF	C33 .. .01 $\mu$ F	C53 .. 25 $\mu$ F	R7 .. 27K	R27 .. 270 $\Omega$	R47 .. 100K
C14 .. 87 pF	C34 .. 20 pF	C54 .. .005 $\mu$ F	R8 .. 180 $\Omega$	R28 .. 1.5K	R48 .. 1K
C15 .. 100 pF	C35 .. .01 $\mu$ F	C55 .. 60 $\mu$ F	R9 .. 3K	R29 .. 220K	PC1 .. 2K lin
C16) .. 3-gang	C36 .. .01 $\mu$ F	C56 .. 75 $\mu$ F	R10 .. 33K	R30 .. As req'd.	VR1 .. 5K lin
C17) .. 22+22+22	C37 .. 100 pF	C57 .. 20 $\mu$ F	R11 .. 1K	R31 .. 1K	VR2 .. 10K lin
C18) .. variable	C38 .. 3 pF	C58 .. 20 $\mu$ F	R12 .. 3.9K	R32 .. 2K	VR3 .. 500K log
C19 .. 5-25 pF	C39 .. 20.5 pF	C59 .. 7.5 pF	R13 .. 330 $\Omega$	R33 .. 27K	X1 .. 1.6197 crystal
C20 .. 5-25 pF	C40 .. 20 pF	C60 .. 7.5 pF	R14 .. 47K	R34 .. 5K	X2 .. 1.6214 crystal



## CIRCUIT DESCRIPTION

To assist you in understanding the following circuit description, we suggest that you refer frequently to the Block Diagram (Page 33) and the Circuit Diagram. As the BAND switch is quite complex, the circuit will be discussed with the switch in the 160 metre position.

### RF AMPLIFIER - MIXER OSCILLATOR

Assuming that the BAND switch is in the 160 metre position, the signal from the antenna is applied through coil L13, through the BAND switch, to the grid of the RF amplifier valve V1.

V1 amplifies the RF signal which is induced through coil L7 to the grid in the heptode section of valve V2.

Valve V2 is a combination mixer and oscillator. This valve heterodynes or mixes the incoming signal frequency with the oscillator frequency to obtain a difference frequency of 1621 Kc/s.

The position of the BAND switch determines which coils and capacitors are used in conjunction with the triode section of the valve V2B in the oscillator circuit. These coils and capacitors, including the main tuning capacitor, are used to set the oscillator frequency 1621 Kc/s higher than the desired radio station frequency, to which the RF and mixer circuits are tuned. The difference frequency of 1621 Kc/s is called the intermediate frequency or IF signal.

For example:-

	Frequency of oscillator .....	3485 Kc/s
(Subtract)	Frequency of signal at antenna .....	1864 Kc/s
	Frequency of difference signal .....	1621 Kc/s

### IF AMPLIFIER

From the anode of V2A, the signal is coupled through IF transformers IFA via a half lattice crystal filter in the secondary winding, to the grid of the first IF amplifier V3. The half lattice crystal filter is included to provide a narrow bandpass for suppression of unwanted adjacent signals. This provides the Receiver with exceptionally good selectivity.

The amplified IF signal from the anode of V3 is coupled through the second IF transformer IFB to the grid of the second IF amplifier valve V4A. Valve V4A again amplifies the IF signal. At this point in the circuit, the Beat Frequency Oscillator (BFO) signal from V4B may be heterodyned (beat) with the IF signal by turning the BFO switch ON. The introduction of the BFO signal (1621 Kc/s  $\pm$  1 Kc/s) produces an audible signal for Continuous Wave (CW) or Single Sideband (SSB) reception. The output from V4A is coupled through IF transformer IFC to diode D1.

### DETECTOR, AUTOMATIC VOLUME CONTROL, NOISE LIMITER STAGES

Diode D1 is the detector stage. This diode detects (or rectifies) the IF signal, and after the filtering out of the RF component, the audio signal passes through the noise limiter stage V5, which when in use, removes peak pulses caused by ignition etc. The diode D2 is the AVC diode which causes some of the voltage from large signals to be fed back to previous stages, in the form of negative bias, to reduce sensitivity.

### AUDIO STAGES

The audio signal controlled through a manual gain control, is applied to the grid of the triode section of valve V6 and is amplified before being passed from the anode of valve V6B to the grid of the pentode section V6A. This section further amplifies the audio signal and feeds it through the transformer OT to the speaker terminals.

### POWER SUPPLY

The power supply uses valve V7 as a full wave rectifier with power transformer MT1. Filtering of the DC voltage is provided by resistors R31, R32, R33 and capacitors C55, C56, C57, C58. Voltage regulation for the oscillators V2B and V4B is provided by V8.

**FIGURE 4**

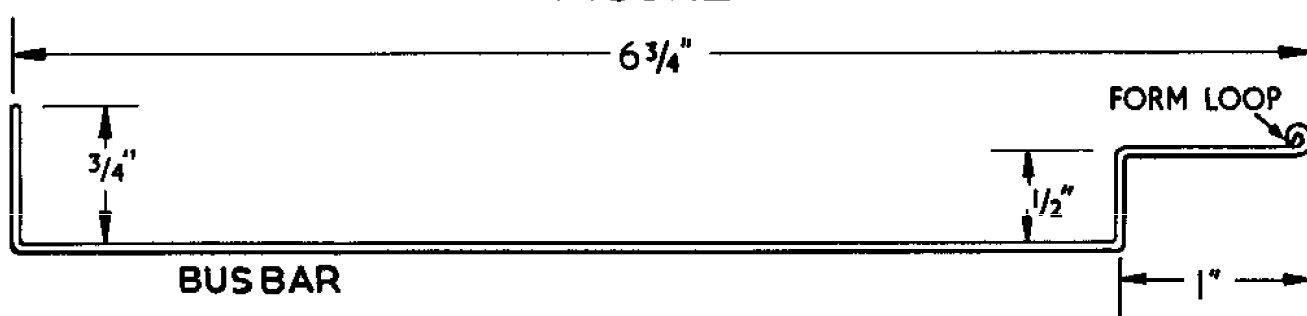

CUT TAGS ET4 AND ET5



**PICTORIAL 2**

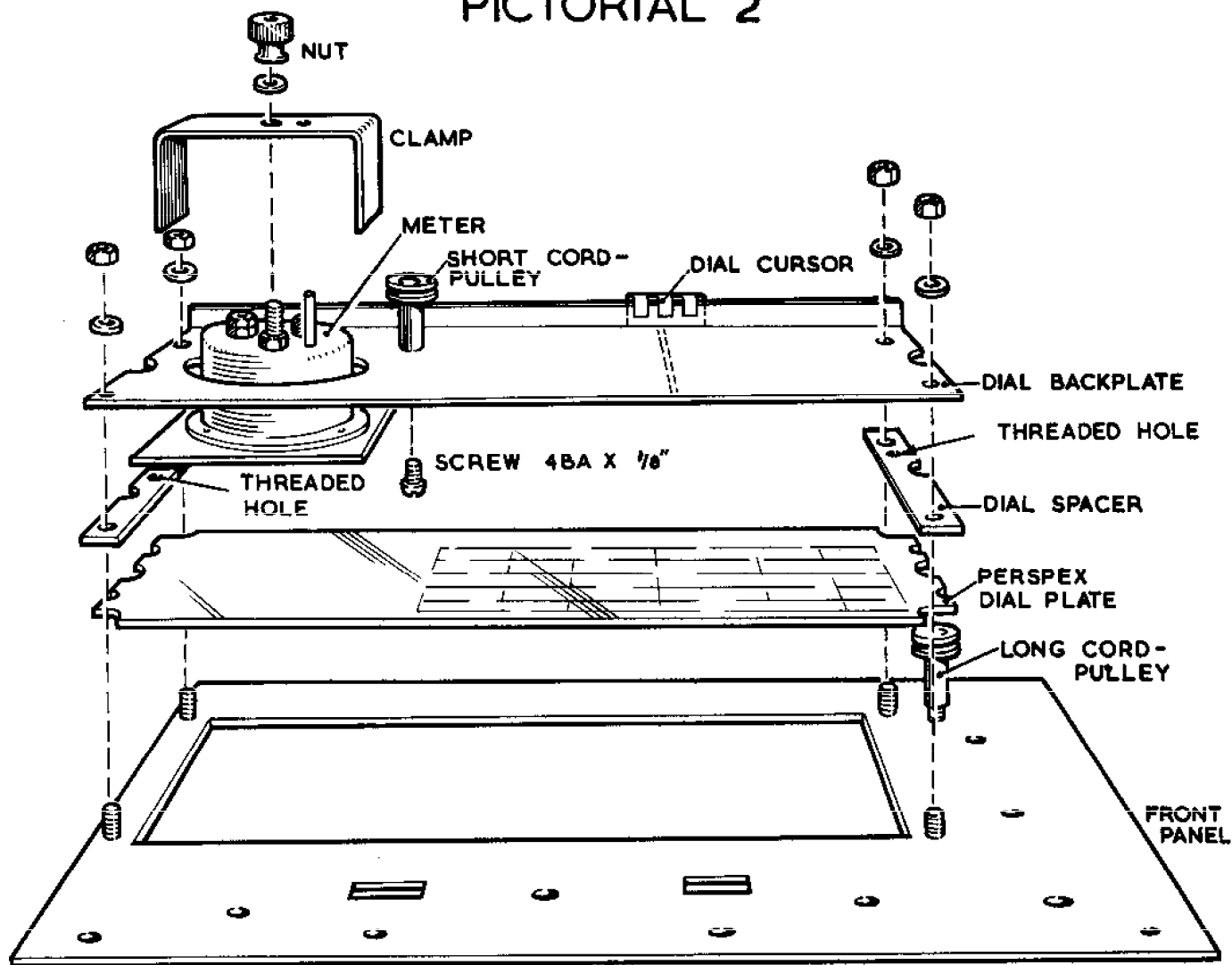

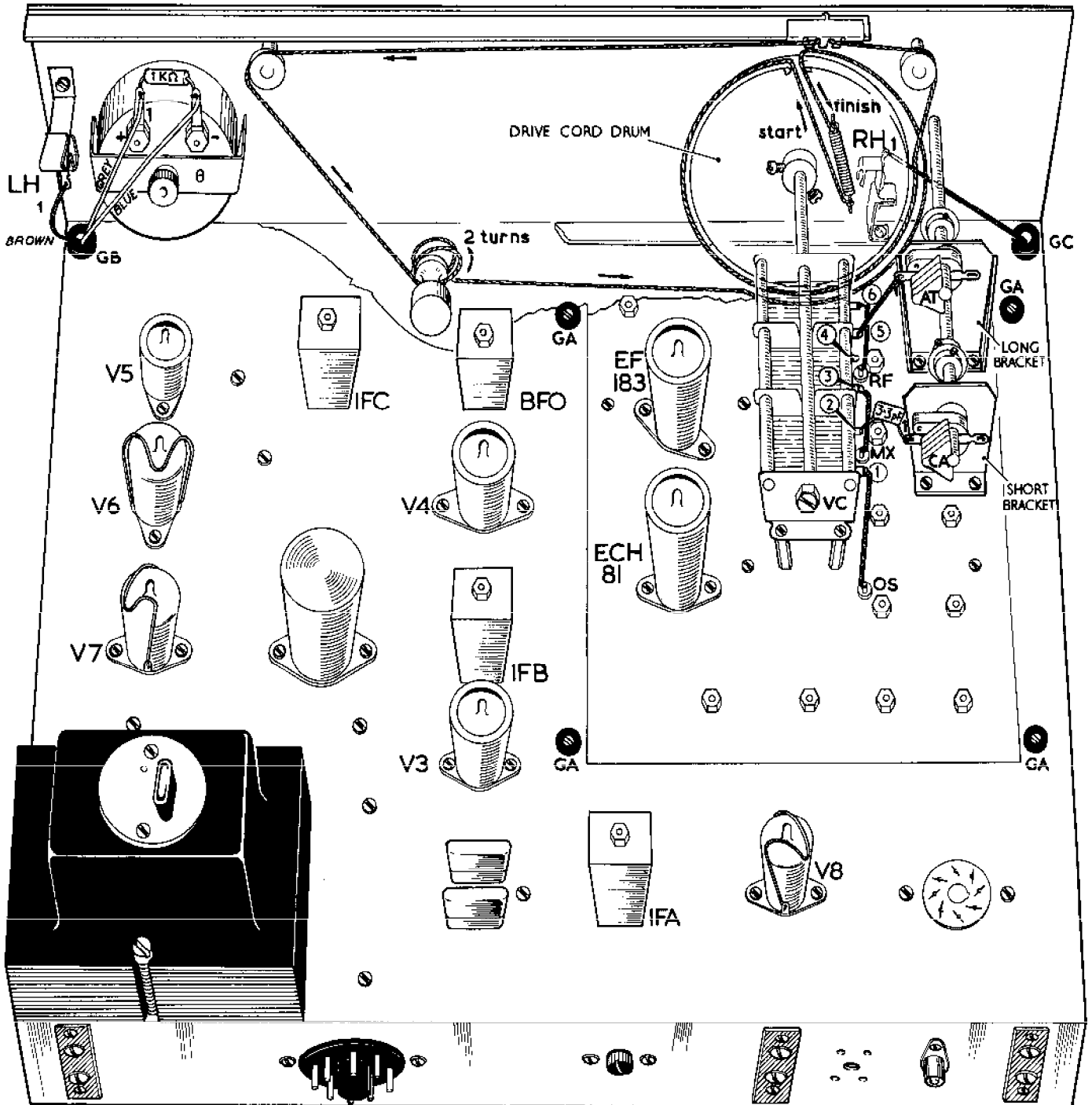

PICTORIAL 3





- (✓) Connect the BROWN wire from grommet GB to LH1 (S-1).
- (✗) Remove one 2BA nut and washer from each meter terminal, fit 2BA solder tags pointing upwards and refit the washers and nuts and tighten.
- (✓) Connect the GREY wire from grommet GB to tag 1 (+) terminal of the meter (NS).
- (✓) Connect the BLUE wire from grommet GB to tag 2 (-) terminal of the meter (NS).
- (✗) Connect a 1 KΩ resistor (BROWN, BLACK, RED) from tag 1 (S-2) to tag 2 (S-2).

#### FITTING DIAL DRIVE CORD AND POINTER

Refer to Pictorial 3 for the following steps:

- (✓) Set the 3-gang capacitor fully meshed and set the slot in the dial drive drum in the 12 o'clock position. Temporarily tighten screws.
- (✓) Locate the dial cord and tie a loop in one end approximately 1" from the end. Place this loop over the tab on the dial drum as shown in Pictorial.
- (✓) Referring to Pictorial, finish stringing the dial cord on the dial drum, dial back plate pulleys, and thence, through hole in chassis, take  $2\frac{1}{2}$  turns around drive spindle and return around drum. Tie the dial cord spring to the free end of cord and attach to tab on dial drum. Do not place too much tension upon spring. Cut off excess cord.
- (✓) Check that the 3-gang capacitor is fully meshed when the slot in the dial drum is at the 12 o'clock position. If necessary, slacken the locking screws and adjust the dial drum on the spindle. At this point ensure that the face of the dial drum is approximately  $1/16$ " clear from the front edge of the chassis aperture. Finally tighten both locking screws.
- (✓) Set the right-hand edge of the pointer body level with the right-hand edge of the dial back plate and slip the cord through the slots in the pointer as shown by Pictorial.

#### ASSEMBLY OF MISCELLANEOUS COMPONENTS

Refer to Pictorial 3 for the following steps:

- (✓) Place a flexible shaft coupler on the spindles of capacitors CA and AT.
- (✓) Place one end of the short shaft (ANT TRIM) through the hole in the front panel and into the open end of the flexible coupler. Tighten grub screw in the coupler.
- (✓) Place one end of the long shaft (CAL ADJ) through the hole in the front panel and front bracket and then into the open end of the flexible coupler. Tighten grub screw in the coupler.
- (✓) Place capacitor plates of CA and AT half meshed. Fit a small pointer knob to each of the control shafts with the pointers upright. Tighten grub screws in the knobs ensuring that the knobs do not rub on the front panel.
- (✓) Set the 3-way rotary switch SC to its mid-position. Fit a small pointer knob to its shaft with the pointer upright (O position). Tighten grub screw.
- (✓) Set the NL control spindle fully anti-clockwise. Fit a small pointer knob to the shaft with the pointer at MIN position. Tighten grub screw.
- (✓) Set the AF and RF GAIN controls fully anti-clockwise. Fit a medium pointer knob to each shaft with the pointer at OFF and MIN positions respectively. Tighten both grub screws.
- (✓) Turn the BAND switch spindle fully anti-clockwise. Fit the remaining medium pointer knob to the shaft with the pointer at 10. Tighten grub screw.
- ( ) Fit a large knob to the TUNING shaft and tighten grub screw.

- ( ) Insert all valves in their respective valveholders and secure with screening cans and retaining springs as indicated in Pictorial.
- ( ) Place a 500 mA fuse in fuse holder FS on underside of chassis.
- ( ) Install a 1.6214 Mc/s crystal in its crystal socket and the 1.6197 Mc/s crystal in its crystal socket.

This completes the assembly of your receiver and it is suggested that at this point, a thorough check is made, to confirm that all steps are in accordance with the Manual and that all joints are properly soldered. You should have a 150 KΩ resistor (BROWN, GREEN, YELLOW) and a 270 KΩ resistor (RED, VIOLET, YELLOW) left after completion. Place these to one side for they may be required for subsequent adjustment of BFO injection.

**INITIAL TEST**

- ( ) Locate the octal socket and octal socket cover. Referring to Figure 6, connect one bare wire link from pin 1 to pin 8 and another link from pin 6 to pin 7. Solder all connections.
- ( ) Connect the mains supply lead to tags 4 and 5 and solder securely. Examine connections to ensure no frayed ends of leads are present to cause accidental short circuits. Use 2½ mm. sleeving.
- ( ) Fit the cover to the socket. **IMPORTANT: THIS MUST BE DONE EVERY TIME ALTERATIONS ARE MADE TO SOCKET CONNECTIONS AS MAINS VOLTAGE IS PRESENT AT TAGS.**
- ( ) Connect a short wirelink between both terminals of the MUTE tagboard at rear of receiver.
- ( ) If an ohmmeter is available, measure the resistance from MP2 to chassis. After approximately 30 secs the resistance should be 30 KΩ or over. If it is lower, refer to the section IN CASE OF DIFFICULTY.
- ( ) Connect the free end of the 5000Ω resistor (from PA1) to TH2 (S-2). Refer to Pictorial 5.
- ( ) Set all front panel controls as follows:-

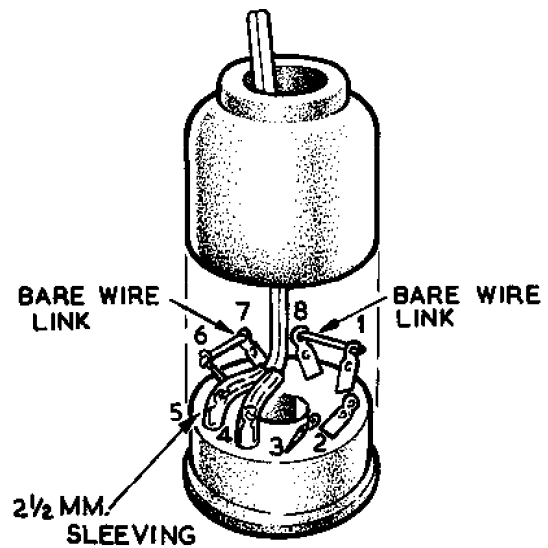

**FIGURE 6**

AF GAIN	OFF
RF GAIN	Maximum clockwise
BFO mode	O
BAND switch	80 metres
NL	MIN
AVC	OFF
BFO	OFF

- ( ) Place the voltage selector plug in the correct tap point to suit your local AC supply voltage. The mains voltage selector board is situated on top of the mains transformer.
- ( ) Connect a 3Ω speaker to the speaker terminals at the rear of the chassis.
- ( ) Fit the octal socket to the octal plug PS at the rear of the chassis.
- ( ) Connect the mains supply lead to an AC mains supply point.
- ( ) Turn the AF GAIN control to the 12 o'clock position. The dial pilot lamps should light immediately. If this is not so, switch off immediately and check heater (BROWN) wiring connections. If bulbs light, the valves will light up slowly. After a few seconds, a rushing noise should be heard in the speaker when the AF GAIN control is turned fully clockwise. If these conditions exist, proceed to the sections FINAL ASSEMBLY and INSTALLATION AND OPERATION. If these conditions do not exist, disconnect from mains supply and refer to the section IN CASE OF DIFFICULTY.

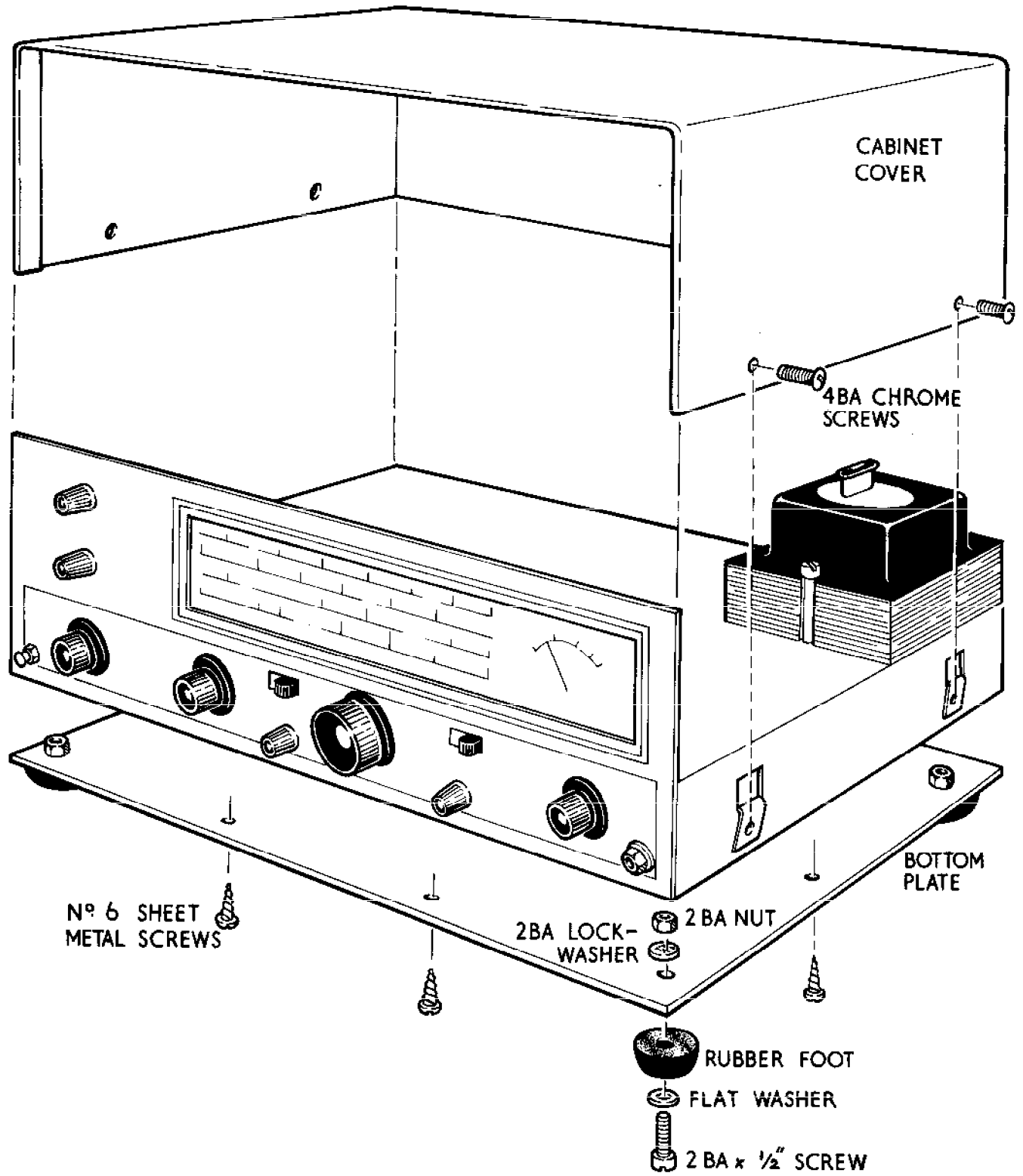

PICTORIAL 6

## FINAL ASSEMBLY AND 'S' METER ZERO ADJUSTMENT

- ( ) Temporarily place a wire link between AE and E terminals.
- ( ) Place the RF GAIN control to maximum clockwise position and switch AVC on. Adjust the meter ZERO ADJUST control on the rear of the receiver for a zero reading on the 'S' meter. Remove the antenna shorting link.
- ( ) Install four rubber feet on the bottom plate as shown in Pictorial 6. Use 2BA x  $\frac{1}{2}$ " screws, lockwashers and nuts.
- ( ) Mount the bottom plate to the chassis with No. 6 sheet metal screws.
- ( ) Place the cabinet cover over the chassis and secure using four chrome plated 4BA screws.

## INSTALLATION AND OPERATION

## Controls

**AF GAIN:** Turns the receiver ON or OFF and varies the volume in the speaker or headphones.

**NL:** When turned to clockwise position, reduces pulse noise interference. Normally used at MIN position.

**RF GAIN:** Varies the amount of gain in the RF and IF amplifier stages.

**USB, O, LSB:** Is controlled by a MODE switch when BFO is switched ON and may be used for SSB (SINGLE SIDE BAND) or CW (CONTINUOUS WAVE) reception. Generally LSB (LOWER SIDE BAND) transmissions are made on the three LF amateur bands (160, 80, 40M) whilst USB (UPPER SIDE BAND) transmissions are made on the three HF amateur bands (20, 15, 10M).

**BAND:** Selects one of the six amateur bands: 160, 80, 40, 20, 15 or 10 metres.

**CAL ADJ:** Provides fine adjustment of the oscillator section of the tuning capacitor for calibration points.

**ANT TRIM:** Peaks the signal at the frequency being received.

**TUNING:** Tunes in the desired station. A slow motion drive is incorporated, that whilst permitting fast traversing, allows a small section to be tuned at a very slow rate.

**MUTING:** Two muting provisions have been incorporated in the receiver. The first is controlled through the MUTE terminals on the rear of the chassis. This condition would be normally used, particularly for CW and SSB operation, for it leaves both the oscillator and BFO stages running and takes the RF and IF stages out of operation. The second provision breaks the total HT supply, and can be employed when a converter is being used and fed from the receiver power supplies. Connection for this facility is made through the octal plug at the rear of the chassis.

## AM OPERATION

BAND switch	Desired band	BFO switch	Off
AVC switch	On	RF GAIN	Maximum clockwise
NL control	MIN	AF GAIN	Comfortable listening level

( ) Rotate the TUNING control until an AM station is tuned in. Proper tuning of the AM signal will be indicated by maximum deflection of the 'S' meter.

( ) Rotate the ANT TRIM control for maximum signal strength.

NOTE: When listening to an extremely strong signal, the RF GAIN control should be turned counter clockwise to prevent blocking.

## CW OPERATION

BAND switch	Desired band	BFO switch	On
MODE switch	O	AVC switch	OFF
AF GAIN	3 o'clock	RF GAIN	3 o'clock



- ( ) Rotate the TUNING control until a CW station is located. See Step 10, Page 29 for BFO adjustment.
- ( ) Adjust RF GAIN control for comfortable listening level.

NOTE: If interfering signals are present, it is, on occasions, an advantage to switch to either USB or LSB to remove unwanted signals and listen under SINGLE SIGNAL condition.

#### SSB OPERATION

For SSB reception, set the controls as explained for CW operation with the following exception - select the wanted sideband using MODE switch. Tune into LSB signals from HF to LF direction on the tuning scale and LF to HF for USB signals. As with CW reception, the listening level should be adjusted with the RF GAIN control, with the AF GAIN control at or near maximum. AVC, if preferred, may be left ON permitting some AGC control.

NOTE: It is possible that due to wiring variations, the BFO injection voltage may require adjustment. This can be achieved by altering R35 (located between tagstrip TB2 and V4 pin 1) in value between 150K $\Omega$  and 360 K $\Omega$  (these resistors are included in the kit). To check for correct injection voltage, tune to a sideband signal on the 20 metre band without BFO switched on. Now switch on BFO. If the station strength decreases BFO injection is too great and R35 should be changed to a higher value. If, however, the signal can only be resolved with considerable reduction of the RF GAIN control, then BFO injection is insufficient and R35 should be changed to a lower value. The BFO must be re-adjusted as outlined in the IF ALIGNMENT section of the Manual.

If the receiver is used for mobile or portable use, power supplies as stated, should be connected to the socket at the rear of the chassis. When used with a 12-14v supply for the heaters, a voltage dropping resistor of 2 ohms 25 watts may be connected between TH1 and TH3, or otherwise external reduction must be made.

#### ANTENNA

The Receiver will operate using a long wire attached to the antenna terminal, however, for the best results, the antenna should have an impedance of 50 to 100 $\Omega$ . This could be a dipole type antenna and constructed for the band that you desire to receive. Naturally, if this Receiver is to be used in conjunction with a transmitter, the transmitting antenna should also be used for reception. For this type of operation, the antenna must be switched from the transmitter to the Receiver. This arrangement would preferably have the input connection to the Receiver earthed down during 'transmit' periods to avoid accidental RF input to the Receiver. If you wish to construct a dipole type of antenna, we suggest that you refer to the R.S.G.B. Radio Amateurs Handbook, available from the Society's Headquarters.

#### RECEIVER ALIGNMENT

The IF transformers and coil pack have been pre-aligned to factory standards, therefore, no further adjustment should be necessary.

Those without instruments are strongly advised not to alter the trimmers on the coil pack, but the IF alignment can be checked by tuning to a weak station, or noise, and adjusting the trimmers on the IF coils for maximum output. Be careful not to screw the cores too far in the coils and so align on the 'inner' peak. *with the exception of the lower core of transformer 1 & 2 allow on inner peak*

The following alignment procedure is recommended for those who wish to check the alignment and have the necessary test equipment.

Refer to Pictorial 3 for the following steps:

#### IF TRANSFORMER ALIGNMENT

Equipment Required: An amplitude modulated RF signal generator and an AC voltmeter.

- ( ) Set all panel controls as follows:-

AF GAIN	12 o'clock	RF GAIN	Maximum clockwise
BFO mode	O	BAND	80 metres
TUNING	3.5 Mc/s	NL	MIN
AVC	OFF	BFO	OFF

- ( ) Connect one lead of the AC voltmeter to the 3 OHM terminal and the other lead to the COMM terminal with the speaker still connected.

- ( ) Connect the positive or 'hot' lead of the signal generator to the AE terminal on rear of chassis and earth lead to E. If convenient this connection may be made co-axially to the co-ax input socket.
- ( ) Turn all the equipment on and let it warm up for approximately 30 minutes to stabilise all circuits.
- ( ) Switch the AC meter to a range between 1 and 3 volts and set the generator for a modulated high output level. The output of the generator should be reduced as the alignment procedure increases the sensitivity of the receiver, to keep the meter readings at approximately  $\frac{3}{4}$  volt.
- ( ) Unscrew core of L19 four turns.
- ( ) Start alignment of the IF transformers by adjusting the signal generator to approximately 1621 Kc/s for maximum indication on the meter. The generator reading at this time may be slightly above or below 1621 Kc/s IF frequency.
- ( ) Adjust the bottom slug of the transformer IFC for maximum meter indication. NOTE: Cores used in the transformers permit the alignment tool to pass through from top to bottom core thus enabling all alignment to be carried out from the top of the receiver. Now adjust top core of IFC for maximum indication. Proceed to transformers IFB and IFA and make a similar adjustment.
- ( ) Swing signal generator for a maximum meter indication, then repeat the IF transformer adjustment as in the preceding step. (Two peaks may be observed indicating each crystal resonance. Set generator to mid-point for final alignment.)
- ( ) Repeat the entire procedure as in the above two steps until further adjustment does not cause an increase in meter reading.
- ( ) Place the BFO switch to the ON position and ensure that mode switch is in the O position. Turn the modulation switch on the signal generator to off. Adjust the core in the BFO coil until you obtain a zero beat.
- ( ) Switch the mode switch to USB and then to LSB which should produce an equal heterodyned pitched note in either position. If the tone is not of the same frequency, re-adjust the BFO coil.
- ( ) Turn the BFO switch to the off position and turn the modulation of the generator on with high level output.
- ( ) Adjust core of L19 for minimum meter reading.
- ( ) This completes the alignment of the IF stages in your receiver. Disconnect the test equipment.

**FRONT END ALIGNMENT**

In order to obtain optimum results from the receiver, the coil pack should be aligned with an accurate amplitude modulated RF signal generator and an AC voltmeter. It is very important that the signal generator be very accurate. Therefore, the generator should be calibrated against a crystal calibrator or a receiver of known accuracy. If the Heathkit Model CL-1 Crystal Calibrator has been purchased, it should be assembled at this time and used to calibrate the signal source.

When performing the following steps, bear in mind that the coil pack has been pre-set by the manufacturer, but due to differences in valves and assembly techniques, some re-alignment may be necessary in order to obtain optimum results. Usually this adjustment will consist of not more than  $\frac{1}{2}$  turn of coil cores or a slight movement of associated capacitors.

- ( ) Set all panel controls as follows:-

AF GAIN	Maximum	RF GAIN	Maximum
BFO mode	O	TUNING	As chart
BAND	As chart	BFO	Off
NL	MIN	AVC	OFF
CAL ADJ	12 o'clock	ANT TRIM	12 o'clock

- ( ) Connect the RF signal generator to the antenna terminals or co-axial socket.
- ( ) Turn all the equipment on and let it warm up for approximately 30 minutes to stabilise all circuits.

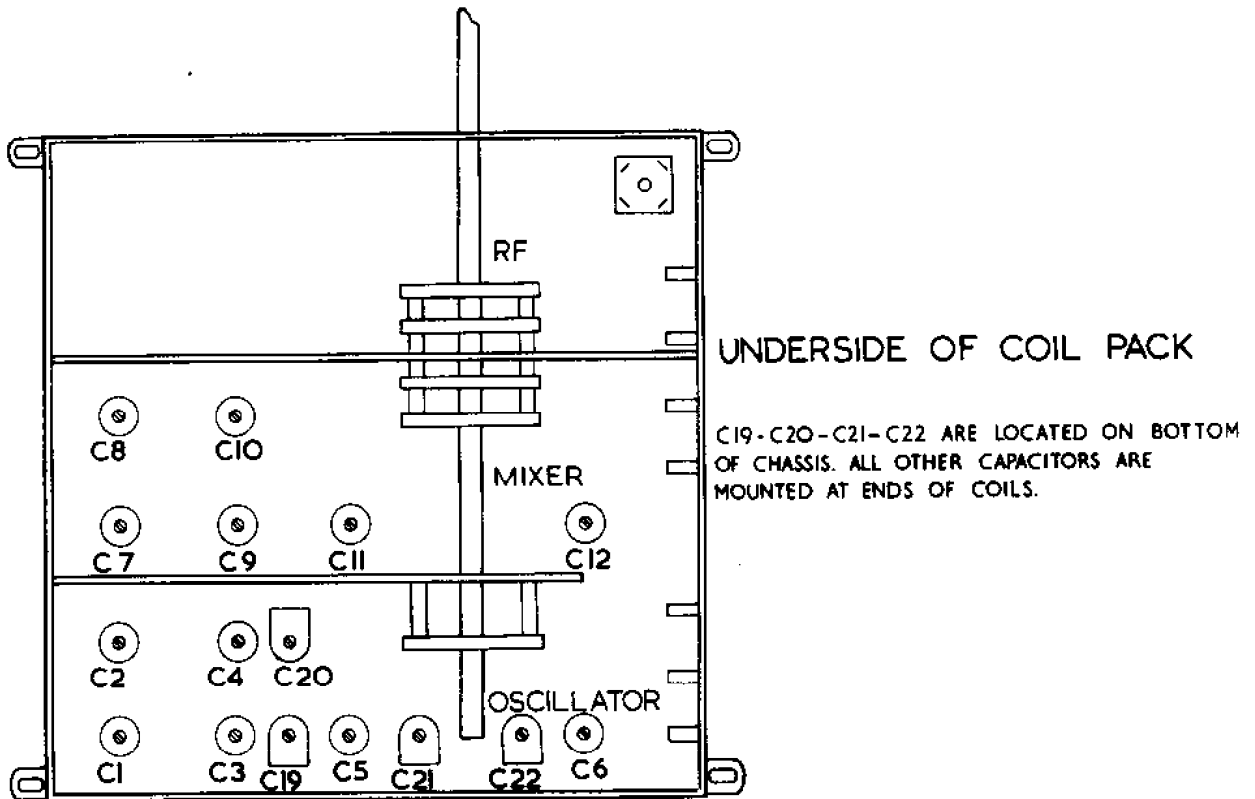
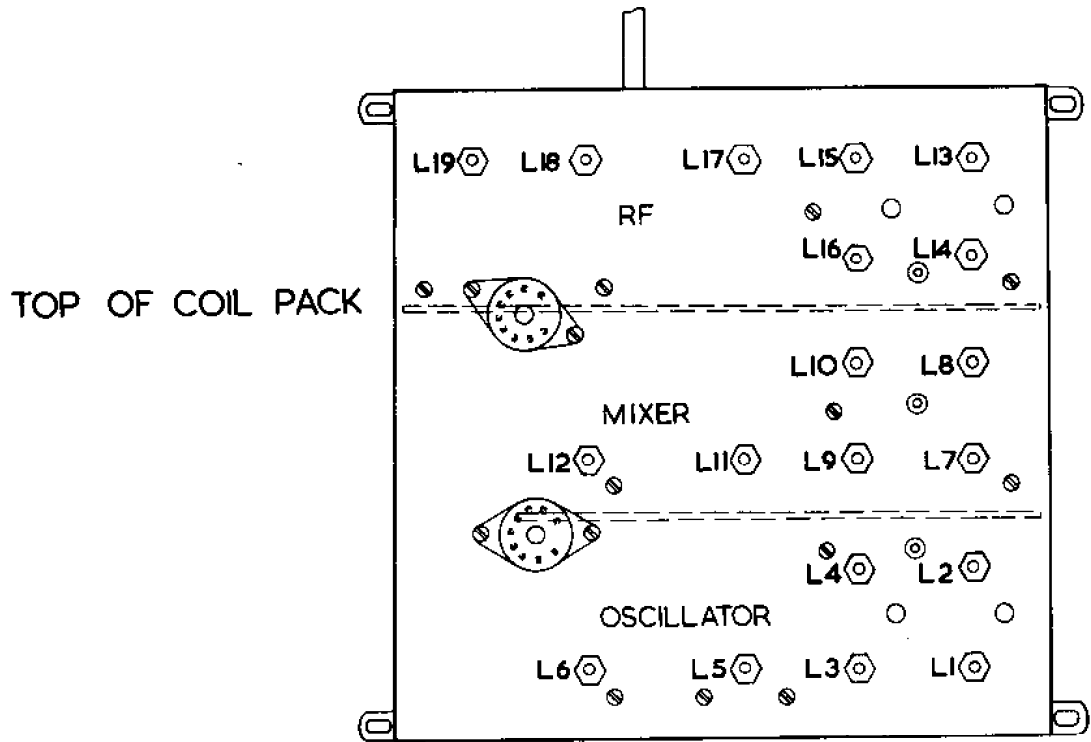

FIGURE 7

- ( ) Connect the AC voltmeter across the speaker terminals with the speaker connected.
- ( ) Set Receiver scale and generator to 1.7 Mc/s. If readings do not coincide, adjust dial cursor on cord.
- ( ) Complete each step as indicated in the following chart. Refer to Figure 7 for the location of each coil and trimmer capacitor. Be sure to keep the signal generator level as low as possible while still obtaining a usable reading of the meter, this should be just above the normal noise level.

## FRONT END ALIGNMENT

BAND SWITCH POSITION	SET RECEIVER AND GENERATOR FREQ TO:-	OSCILLATOR ADJUST FOR SIGNAL	MIXER AND RF ADJUST FOR MAX OUTPUT
160 Metres	1.7 Mc/s 2.0 Mc/s	L1 C1	L7 and L13 C7 and ANT TRIM
80 Metres	3.5 Mc/s 4.0 Mc/s	L2 C2	L8 and L14 C8 and ANT TRIM
40 Metres	7.0 Mc/s 7.3 Mc/s	C19* C3	L9 and L15 C9 and ANT TRIM
20 Metres	14.0 Mc/s 14.40 Mc/s	C20* C4	L10 and L16 C10 and ANT TRIM
15 Metres	21.0 Mc/s 21.5 Mc/s	C21* C5	L11 and L17 C11 and ANT TRIM
10 Metres	28.0 Mc/s 30.0 Mc/s	C22* C6	L12 and L18 C12 and ANT TRIM

\* C19, C20, C21 and C22 are oscillator padding capacitors.

L3, L4, L5 and L6 cores must not be adjusted.

## IN CASE OF DIFFICULTY

1. Recheck the wiring. Trace each lead in coloured pencil on the Pictorial as it is checked. It is frequently helpful to have a friend check your work. Someone who is not familiar with the unit may notice something consistently overlooked by the constructor.
2. It is interesting to note that about 90% of the kits that are returned for repair, do not function properly due to poor connections and soldering. Therefore, many troubles can be eliminated by reheating all connections to make sure that they are soldered as described in the section PROPER SOLDERING PROCEDURE of this manual.
3. Check to be sure that all valves are in their proper locations. Make sure that all valves light up properly.
4. Check the valves with a valve tester or by substitution of valves of the same types and known to be good.
5. Check the values of the parts. Be sure that the proper part has been wired into the circuit, as shown in the Pictorial Diagrams and as called up in the wiring instructions.
6. Check for bits of solder, wire ends or other foreign matter which may be lodged in the wiring.
7. If, after careful checks, the trouble is still not located and a voltmeter is available, check voltage readings against those shown on the Voltage Chart. NOTE: All voltage readings were taken with a 20,000Ω per volt voltmeter. Voltages may vary as much as 10%.
8. A review of the CIRCUIT DESCRIPTION will prove helpful in indicating where to look for trouble.





## SPECIFIC PROBLEMS

PROBLEM	CHECK
<p>Heaters do not light</p> <p>Heaters light, but no sound with GAIN controls fully clockwise</p>	<ol style="list-style-type: none"> <li>1. Check fuse.</li> <li>2. Check heater wiring.</li> <li>3. Open circuit valve heater - Check continuity with an ohmmeter.</li> <li>4. Check power transformer wiring against Pictorial 3.</li> </ol> <ol style="list-style-type: none"> <li>1. Make sure that links (check operating relays if used) are fitted to octal socket, check muting circuit.</li> <li>2. Check wiring of the GAIN controls.</li> </ol> <div style="border: 1px solid black; padding: 5px; margin: 10px 0;"> <p>CAUTION: When making the following checks, do not touch the chassis with your other hand. Be sure that the chassis is not connected to an earthing point and that you touch only the specified pin on the valveholder.</p> </div> <ol style="list-style-type: none"> <li>3. Turn the Receiver on and place the tip of a small screwdriver on pin 8 of V6, then touch your finger to the metal portion of the screwdriver; a low pitched hum should be audible.</li> <li>4. Now place the screwdriver on pin 1 of V6. Again touch your finger to the metal portion, this time the hum should be louder.</li> </ol> <p>If no hum is present check valve voltages against chart and check the components of valve V6 and wiring to speaker.</p>
<p>Audio present - no signals can be heard</p>	<p>Again when making the following tests do not touch the chassis with your hand.</p> <p>Check NL control is in MIN position.</p> <ol style="list-style-type: none"> <li>1. Place a small screwdriver on pin 7 of V5. Touch the metal portion of the screwdriver, a low pitched hum should be heard.</li> </ol> <p>If no hum is present check valve voltages against chart and check components around V5.</p> <ol style="list-style-type: none"> <li>2. Similarly make the screwdriver test on pin 2 of V4. A loud click should be heard.</li> <li>3. Similarly repeat the screwdriver test on pin 2 of V3. A loud click should be heard.</li> <li>4. Similarly repeat the screwdriver test on pin 2 of V2. A loud click should be heard.</li> <li>5. Similarly repeat the screwdriver test on pin 2 of V1. A loud click should be heard.</li> </ol> <p>If no hum or click is heard or if the hum level does not increase check valve voltages against the chart and check components around valveholder.</p>

VALVE VOLTAGE CHART

TYPE	VALVE REF.	Pin 1	Pin 2	Pin 3	Pin 4	Pin 5	Pin 6	Pin 7	Pin 8	Pin 9
EF183	V1	4v	-	-	6.3v*	-	-	135v	105v	-
ECH81	V2	70v	-	1.7v	6.3v*	-	140v	-	135v	-
EF183	V3	1.8v	-	-	-	6.3v*	-	135v	70v	-
ECF82	V4	20v	-	90v	6.3v*	-	125v	1.7v	-	-
EB91	V5	60v	58v	4v*	-	60v	-	61v	-	-
ECL86	V6	-	1v	230v	6.3v*	-	300v	7v	-	115v
EZ81	V7	275v*	-	300v	6.3v*	-	-	275v*	-	-
OA2	V8	-	-	-	-	150v	-	-	-	-

\* Indicates AC.

Measurement pin 1 of V4 with BFO ON.

Measurement taken for DC voltages with meter sensitivity of 20,000Ω per volt.

HT MEASUREMENTS AT POINTS INDICATED IN CIRCUIT DIAGRAM

HT1 - 300 volt,    HT2 - 235 volt,    HT3 - 150 volt,    HT4 - 220 volt,    HT5 - 150 volt.

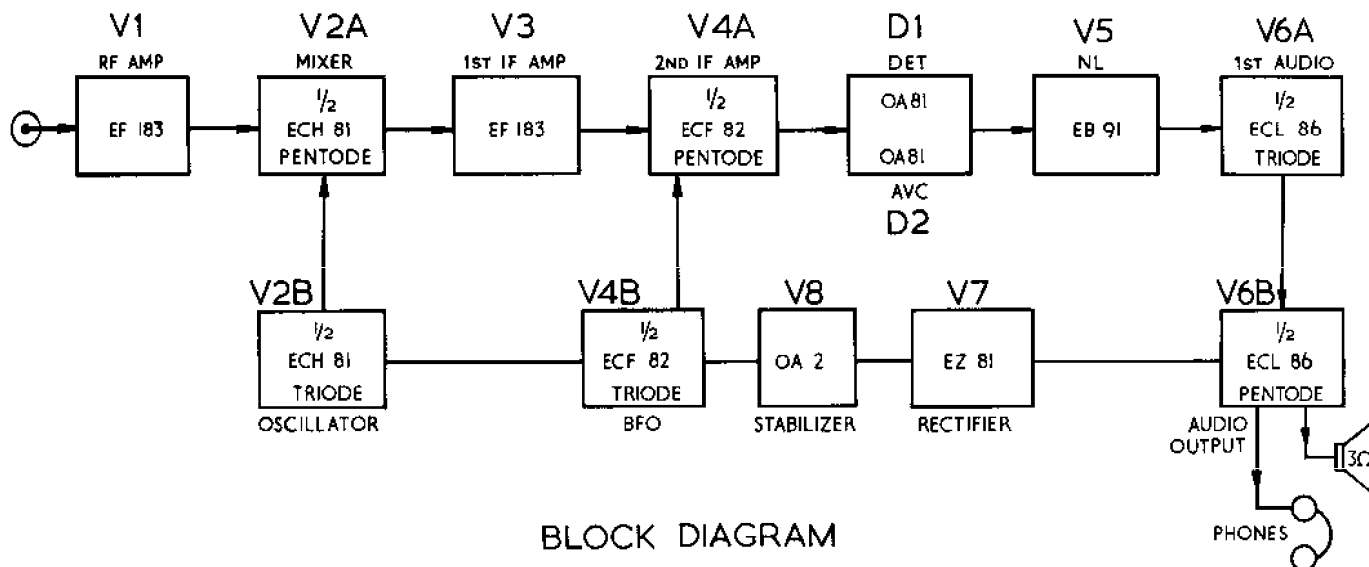



## PARTS LIST

PART No.	PARTS Per Kit	DESCRIPTION	PART No.	PARTS Per Kit	DESCRIPTION
Resistors ( $\frac{1}{2}$ watt, 10%, carbon)			Valves, Diodes, Meter (cont'd.)		
H-100C10	✓	10 $\Omega$ (Brown, Black, Black)	✓411-512	1	EZ81 valve
H-331C10	✓	330 $\Omega$ (Orange, Orange, Brown)	✓411-515	1	OA2 or equivalent
H-471C10	✓	470 $\Omega$ (Yellow, Violet, Brown)	Metalwork		
H-102C10	✓	1 K $\Omega$ (Brown, Black, Red)	90-525	1	Cabinet
H-222C10	✓	2.2 K $\Omega$ (Red, Red, Red)	✓200-544	1	Chassis
H-392C10	✓	3.9 K $\Omega$ (Orange, White, Red)	✓203-55	1	Front panel
H-562C10	✓	5.6 K $\Omega$ (Green, Blue, Red)	✓205-545	1	Dial back plate
H-223C10	✓	22 K $\Omega$ (Red, Red, Orange)	205-544	2	Spacer
H-333C10	✓	33 K $\Omega$ (Orange, Orange, Orange)	204-568	1	Ant trim bracket
H-473C10	✓	47 K $\Omega$ (Yellow, Violet, Orange)	204-569	1	Cal Adj bracket
H-104C10	4	100 K $\Omega$ (Brown, Black, Yellow)	204-567	1	Drive bracket
H-154C10	✓	150 K $\Omega$ (Brown, Green, Yellow)	204-566	1	L.H. lamp bracket
H-224C10	✓ 6 5	220 K $\Omega$ (Red, Red, Yellow)	204-565	1	R.H. lamp bracket
H-274C10	✓	270 K $\Omega$ (Red, Violet, Yellow)	✓601-501	1	Bottom plate
H-564C10	✓	560 K $\Omega$ (Green, Blue, Yellow)	Metal Parts		
H-105C10	✓	1 megohm (Brown, Black, Green)	434-545	2	Dial lampholder
H-225C10	✓	2.2 megohm (Red, Red, Green)	456-501	2	Spindle coupler
Resistors (1 watt, 10% carbon)			453-517	1	Short shaft, 1.5/8"
1-100C10	✓	10 $\Omega$ (Brown, Black, Black)	453-518	1	Long shaft, 3.1/2"
1-271C10	✓	270 $\Omega$ (Red, Violet, Brown)	606-503	1	Slow motion drive
1-152C10	✓	1.5 K $\Omega$ (Brown, Green, Red)	455-502	1	3/8" x 1/4" panel bush and nut
1-273C10	✓	27 K $\Omega$ (Red, Violet, Orange)	481-502	1	Capacitor mounting plate
Resistors (wire-wound)			463-510	1	Dial pointer, 3.1/2"
8-102W5	✓	1000 $\Omega$ 8 watt	100-543	1	Long cord pulley assembly
8-202W5	✓	2000 $\Omega$ 8 watt	100-541	1	Short cord pulley assembly
8-502W5	✓	5000 $\Omega$ 8 watt	435-501	1	Spring retaining ring
Capacitors (all types)			206-502	1	B9 valve screen can (long)
20-501	2	200 pF silver mica	206-501	3	B9 valve screen can (short)
20-540	1	15 pF silver mica moulded	206-506	1	B7 valve screen can
20-52	2	7.5 pF silver mica	258-508	2	B9 valve retaining spring (long)
21-542	1	3.3 pF tubular ceramic (maybe coded Black, Orange, Orange, White, Orange)	258-506	1	B7 valve retaining spring (short)
21-522	12	5000 pF disc ceramic (.005 $\mu$ F)	100-544	1	Dial drum with (2) screws
21-544	1	.01 $\mu$ F encapsulated (coded Brown, Black, Orange, Black)	258-503	1	Dial cord spring
21-545	3	.1 $\mu$ F encapsulated (coded Brown, Black, Yellow, Black)	Controls, Switches		
23-517	1	.005 $\mu$ F tubular paper, 600v	19-519	1	500 K $\Omega$ potentiometer with switch
23-525	1	.25 $\mu$ F tubular paper, 150v	10-546	1	10 K $\Omega$ potentiometer
25-531	2	20 $\mu$ F electrolytic, 350v	10-547	1	5 K $\Omega$ potentiometer
25-501	1	25 $\mu$ F electrolytic, 25v	10-548	1	2 K $\Omega$ pre-set potentiometer
25-535	1	60+75 $\mu$ F electrolytic, 450v	636-502	1	Press switch
26-503	2	20.5 pF variable trimmer	63-549	1	3-way rotary switch
26-525	1	3-gang variable tuning	60-512	1	SPST slide switch
Valves, Diodes, Meter			60-513	1	DPST slide switch
✓407-509	1	'S' meter	Plugs, Sockets, Valveholders		
✓56-501	2	OA81 diode	434-544	2	Crystal holder
✓411-533	2	EF183 valve	436-507	1	Phone jack
✓411-530	1	ECH81 valve	432-506	1	Co-axial socket
✓411-534	1	ECF82 valve	438-504	1	Co-axial plug
✓411-532	1	ECL86 valve	434-539	1	Octal plug chassis mounting
✓411-40	1	EB91 valve	434-540	1	Octal socket (with cover)
			434-503	1	Octal valveholder
			434-516	1	7-pin valveholder
			434-517	1	7-pin skirted valveholder
			434-502	2	9-pin valveholder

## PARTS LIST (cont'd.)

PART No.	PARTS Per Kit	DESCRIPTION	PART No.	PARTS Per Kit	DESCRIPTION
Plugs, Sockets, Valveholders (cont'd.)			Tagstrips (cont'd.)		
434-501	2	9-pin skirted valveholder	431-524	1	6-way tagstrip (double fixing)
			431-518	3	2-lug screwed terminal
Coils, Transformers			Hardware		
✓52-513	1	IF transformer (Red spot)	253-501	6	3/8" flat washer
✓52-514	1	IF transformer (Yellow spot)	250-512	4	2BA x 1/2" binderhead screw
✓52-515	1	IF transformer (Green spot)	252-503	4	2BA nut
✓40-589	1	BFO coil	254-502	6	2BA lockwasher
✓54-507	1	Mains transformer	259-507	2	2BA solder tag
✓51-519	1	Output transformer	250-567	4	4BA special shouldered screw
✓100-545	1	Coil pack	250-513	23	4BA x 1/4" binderhead screw
			250-514	4	4BA x 3/8" b'hd. chrome screw
Crystals			250-530	2	4BA x 1/8" ch.hd. screw
✓404-502	1	1.6214 Mc/s	252-3U	31	4BA nut
✓404-503	1	1.6197 Mc/s	254-1	28	4BA lockwasher
Wire, Cable			259-504	6	4BA solder tag
343-503	1 length	Co-axial cable	250-568	2	6BA x 3/8" ch.hd. nylon screw
343-3	1 length	Screened cable	250-527	4	6BA x 1/4" c'sk. hd. screw
344-501	1 length	Brown connecting wire	250-501	23	6BA x 1/4" binderhead screw
344-506	1 length	Blue connecting wire	250-545	2	6BA x 1/8" c'sk.hd. chrome screw
344-508	1 length	Grey connecting wire	252-501	25	6BA nut
344-521	1 length	Pink connecting wire	254-501	20	6BA lockwasher
344-502	1 length	Red connecting wire	253-503	4	6BA plain washer
344-505	1 length	Green connecting wire	259-505	9	6BA solder tag
344-500	1 length	Black connecting wire	250-8	8	No.6 sheet metal screw, 3/8"
344-509	1 length	White connecting wire	Miscellaneous		
344-507	1 length	Violet connecting wire	100-546	1	Wiring harness
344-504	1 length	Yellow connecting wire	73-504	6	1/4" grommet
344-503	1 length	Orange connecting wire	261-501	4	Rubber feet
340-503	1 length	18 swg. bare copper wire	423-504	1	Fuse holder
340-501	1 length	22 swg. bare copper wire	421-507	1	500 mA fuse
331-501	1 length	18 swg. solder	412-4	2	Dial lamp, 6.3v x 110 mA
346-1	1 length	1 mm. sleeving	✓320-513	1	Perspex dial
346-502	1 length	2 1/2 mm. sleeving	462-523	1	Large plain knob (1.9/16")
89-1	1 length	Mains lead	462-506	3	Medium pointer knob (1.1/8")
			462-520	4	Small pointer knob (9/16")
Tagstrips			252-527	4	4BA speed nut
431-501	1	1-way tagstrip	349-501	1 length	Dial cord
431-10	2	3-way tagstrip	630-501	1	Nut starter
431-519	1	4-way tagstrip	✓490-503	1	Hexagon trimmer
431-532	1	5-way tagstrip	✓595-565	1	Manual
431-506	2	7-way tagstrip			