

SPECIFICATIONS

RECEIVER

Sensitivity.	Less than 0.5 microvolt for 10 db signal-plus-noise to noise ratio for SSB operation.
SSB Selectivity.	2.1 kHz minimum at 6 db down, 5 kHz maximum at 60 db down (3.395 MHz filter). (2:1 nominal shape factor at 60:6 db.)
CW Selectivity (With SBA-301-2 CW Filter Installed).	400 Hz minimum at 6 db down, 2.0 kHz maximum at 60 db down.
Input.	Low impedance for unbalanced coaxial input.
Output Impedance.	8 Ω speaker, and high impedance headphone.
Power Output.	2 watts with less than 10% distortion.
Spurious Response.	Image and IF rejection better than 50 db. Internal spurious signals below equivalent antenna input of 1 microvolt.

TRANSMITTER

DC Power Input.	SSB: (A3a emission) 180 watt P.E.P. (normal voice: continuous duty cycle). CW: (A1 emission) 170 watts (50% duty cycle).
RF Power Output.	100 watts on 80 through 15 meters; 80 watts on 10 meters (50 Ω nonreactive load).
Output Impedance.	50 Ω to 75 Ω with less than 2:1 SWR.
Oscillator Feedthrough Or Mixer Products.	55 db below rated output.
Harmonic Radiation.	45 db below rated output.
Transmit-Receive Operation.	SSB: PTT or VOX. CW: Provided by operating VOX from a keyed tone, using grid-block keying.
CW Side-Tone.	Internally switched to speaker or headphones, in CW mode. Approximately 1000 cps tone.
Microphone Input.	High impedance with a rating of -45 to -55 db.
Carrier Suppression.	50 db down from single-tone output.
Unwanted Sideband Suppression.	55 db down from single-tone output at 1000 Hz reference.
Emissions not possible or not recommended.	A0, A2, A3, A3b, A4 through A9, F0 through F9, and P0 through P9.



Third Order Distortion.	30 db down from two-tone output.
RF Compression (TALC*).	10 db or greater at .1 ma final grid current.

GENERAL

Frequency Coverage.	3.5 to 4.0; 7.0 to 7.3; 14.0 to 14.5; 21.0 to 21.5; 28.0 to 28.5; 28.5 to 29.0; 29.0 to 29.5; 29.5 to 30.0 (megahertz).
Frequency Stability.	Less than 100 hertz per hour after 20 minutes warmup from normal ambient conditions. Less than 100 Hz for $\pm 10\%$ line voltage variations.
Modes Of Operation.	Selectable upper or lower sideband (suppressed carrier) and CW.
Visual Dial Accuracy.	Within 200 Hz on all bands.
Electrical Dial Accuracy.	Within 400 Hz after calibration at nearest 100 kHz point.
Dial Mechanism Backlash.	Less than 50 Hz.
Calibration.	100 kHz crystal.
Audio Frequency Response.	350 to 2450 Hz.
Phone Patch Impedance.	8 Ω receiver output to phone patch; high impedance phone patch input to transmitter.
Front Panel Controls.	Main (LMO) tuning dial. Driver tuning and Preselector. Final tuning. Final loading. Mic and CW Level control. Mode switch. Band switch. Function switch. Freq Control switch. Meter switch. RF Gain control. Audio Gain control. Filter switch.

*Triple Action Level Control™

Internal Controls.	VOX Sensitivity. VOX Delay. ANTI-TRIP. Carrier Null (control and capacitor). Meter Zero control. CW tone volume. Relative Power Adjust control. Bias. Phone Vol (headphone volume). Neutralizing.
Tube Complement.	OA2 Regulator (150 V). 6AU6 RF amplifier. 6AU6 1st receiver mixer. 6AU6 Isolation amplifier. 6AU6 1st IF amplifier. 6AU6 2nd IF amplifier. 6BN8 Product detector and AVC. 6CB6 LMO. 6CB6 2nd transmitter mixer. 6CL6 Driver. 6EA8 Speech Amplifier and cathode follower. 6EA8 1st transmitter mixer and crystal oscillator. 6EA8 2nd receiver mixer and relay amplifier. 6EA8 CW side-tone oscillator and amplifier. 6GW8 Audio amplifier and audio output. 12AT7 Heterodyne oscillator and cathode follower. 12AT7 VOX amplifier and calibrator oscillator. 12AU7 Sideband oscillator. 6146 Final amplifiers (2).
Diode Complement.	6 Germanium Diodes: Balanced modulator, RF sampling, and crystal calibrator harmonic generation. 9 Silicon Diodes: ALC rectifiers, anti-trip rectifiers, and DC blocking. 1 Zener Diode: cathode bias.



Rear Apron Connections.	CW Key jack, 8 Ω output, Phone patch input, ALC input, Power and accessory plug, RF output, Antenna switch, Receiver Antenna, Spare A. Spare B.
Power Requirements.	700 to 850 volts at 250 ma with 1% maximum ripple, 300 volts at 150 ma with .05% maximum ripple, -115 volts at 10 ma with .5% maximum ripple, 12 volts AC/DC at 4.76 amps.
Cabinet Dimensions.	14-7/8" wide x 6-5/8" high x 13-3/8" deep
Net Weight.	17-1/2 lbs.
Equipment Used To Prepare Specifications.	Heath HN-31 "Cantenna," Heath SB-610 Monitor Scope, Heath IM-11 VTVM, Heath MM-1 VOM, Heath IG-72 Audio Generator, Heath HDP-21A Microphone, Hewlett-Packard Electronic Counter, Model 524B, Tektronix Oscilloscope, Model 581A, Hewlett-Packard Signal Generator, Model 606A, Panoramic Radio Products Inc., "Panalyzer," Model SB-12A, Boonton RF Voltmeter, Model 91-CA, Dynascan Digital Voltmeter, Model 111.

The Heath Company reserves the right to discontinue instruments and to change specifications at any time without incurring any obligation to

incorporate new features in instruments previously sold.

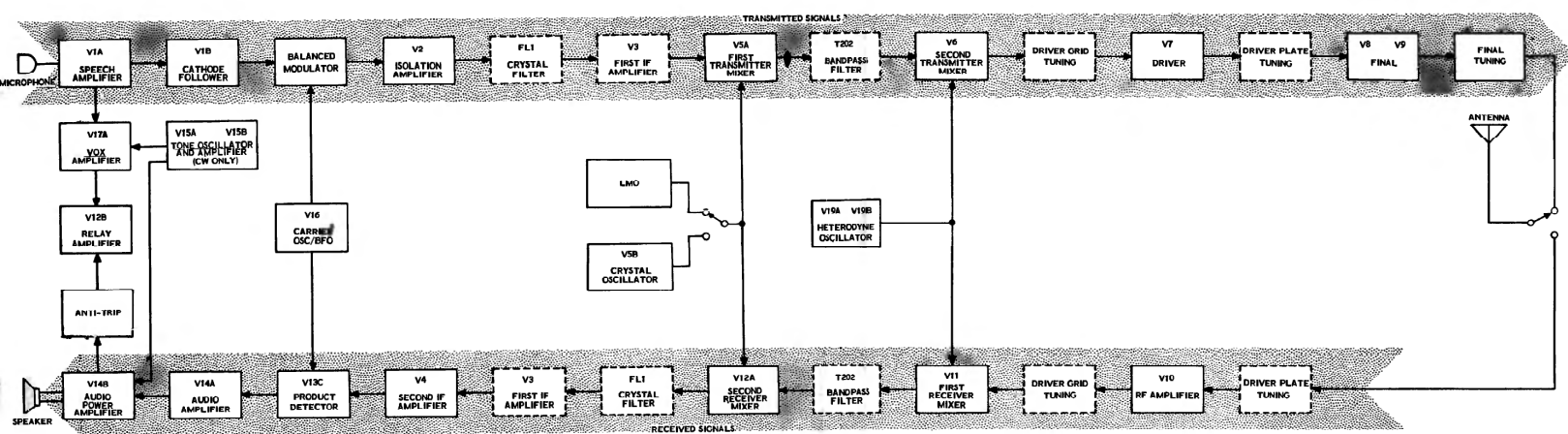

THESE BLOCKS ARE FOR THE CIRCUITS THAT ARE USED IN BOTH THE TRANSMITTER AND RECEIVER MODES OF OPERATION.

BLOCK DIAGRAM



CIRCUIT DESCRIPTION

Refer to the Block Diagram (fold-out from Page 124) and to the Schematic (fold-out from Page 151) while reading the Circuit Description. Small sections of the Schematic are also included in this Description to make the circuits easier to follow.

Note that the receiver circuits are across the bottom, and the transmitter circuits are across the top of the Schematic and Block Diagrams. Also, several of the circuits that are used for transmitting are also used for receiving (such as the crystal filter and the first IF amplifier). These circuits, which are shown in both the transmitter and receiver portions of the Block Diagram, are identified in the Block Diagram by dotted lines.

Each rotary switch wafer is identified by the front panel name of the switch, and by a letter-number designation that shows the position of that wafer in the switch. See Figure 2-1.

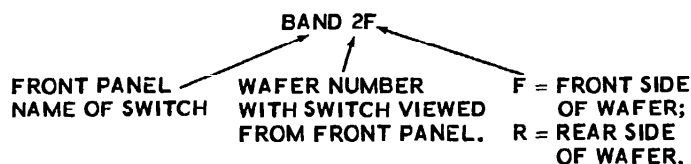

Figure 2-1

BAND	CARRIER OSCILLATOR (3393.6 kHz plus 1400 Hz modulation), CRYSTAL FILTER AND IF FREQUENCIES	LMO FREQUENCY (BETWEEN 5 AND 5.5)	SIGNAL FREQUENCY AT BANDPASS FILTER (BETWEEN 8.395 AND 8.895)	HETERODYNE OSCILLATOR FREQUENCY (CRYSTAL FIXED)	TRANSMITTED SIGNAL FREQUENCY
3.5 to 4	3.395	5.105	8.5	12.395	3.895
7 to 7.5	3.395	5.3	8.695	15.895	7.2
14 to 14.5	3.395	5.3	8.695	22.895	14.2
21 to 21.5	3.395	5.2	8.595	29.895	21.3
28 to 28.5	3.395	5.4	8.795	36.895	28.1
28.5 to 29	3.395	5.3	8.695	37.395	28.7
29 to 29.5	3.395	5.3	8.695	37.895	29.2
29.5 to 30	3.395	5.4	8.795	38.395	29.6

All frequencies are in MHz.

Figure 2-2

Letter number designations for the resistors, capacitors, coils, etc., are placed in the following groups:

0- 99	Parts on modulator circuit board.
100-199	Parts on IF circuit board.
200-299	Parts on bandpass circuit board.
300-399	Parts on audio circuit board.
400-499	Parts on RF-driver circuit board.
500-599	Parts on crystal circuit board.
600-699	Parts on heterodyne oscillator circuit board.
700-799	Parts on driver grid circuit board.
800-899	Parts on driver plate circuit board.
900-999	Parts mounted on the chassis.

TRANSMITTER CIRCUITS

The chart in Figure 2-2 lists the various frequencies that will be found throughout the transmitter on each band. The transmitted lower sideband frequency of 3.895 MHz, modulated with a 1400 hertz audio tone, which is shown on the first line, will be used when tracing through the transmitter circuits. The other frequencies referred to in this Circuit Description will also be found on the first line.

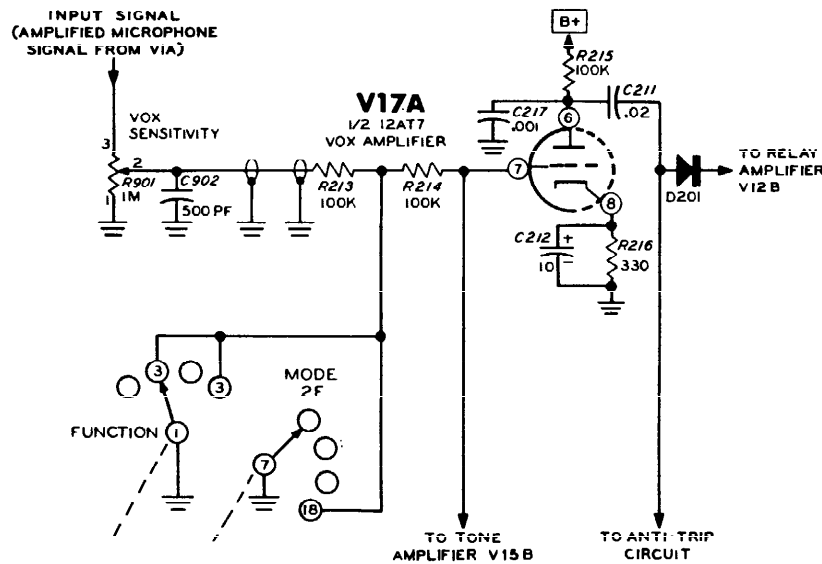

Figure 2-3

VOX Amplifier (Figure 2-3)

The Transceiver can be switched from receive to transmit by either the VOX (voice operated transmitter) or the push-to-talk method. The VOX circuit works in the following manner:

The audio signal from the microphone is coupled through speech amplifier V1A and capacitor C9 to the VOX Sensitivity control. From the arm of this control, for VOX operation, the signal is coupled through resistors R213 and R214 to the grid of VOX amplifier V17A. The signal is amplified in V17A. It is then coupled through capacitor C211, rectified by diode D201, and applied to relay amplifier V12B, which actuates the transmit-receive relays.

In the PTT and Calibrate positions of the Function switch, and in the CW position of the Mode switch, the lead from the VOX Sensitivity control to the grid of V17A is connected to ground. This keeps stray microphone signals from activating the VOX circuit during PTT and CW operation, or during calibration.

Relay Amplifier (Figure 2-4)

Relay amplifier V12B is held in cutoff during receive operation by the positive voltage that is maintained at its cathode by zener diode D202. V12B is made to conduct for transmit operation by the VOX voltage at its grid, or by the push-to-talk switch on the microphone which shorts the cathode to ground. (The cathode of V12B is also shorted to ground by wafer 2F of the Mode switch in the Tune position.) Diode D201 rectifies the audio signal from the VOX amplifier so that a positive voltage appears at the grid of relay amplifier V12B. The positive voltage at the grid causes the relay amplifier to conduct, and the plate current of V12B causes relays RL1 and RL2 to close and place all circuits in the transmit mode of operation.

The VOX hold-in time is adjusted by varying the discharge time for capacitor C213 with the VOX Delay control.

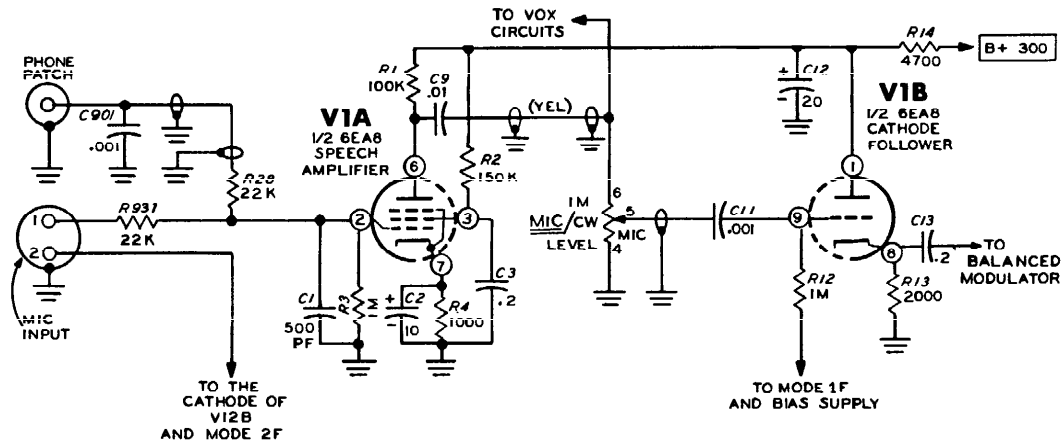

Figure 2-6

Speech Amplifier And Cathode Follower (Figure 2-6)

The audio signal from the microphone is coupled directly from lug 1 of the Microphone input socket to the grid of speech amplifier V1A. Lug 2 of the Microphone input socket is returned to ground through the push-to-talk switch on the microphone. The cathode of relay amplifier V12B is also connected to lug 2 so it will be returned to ground when the push-to-talk switch is depressed, to operate the transmit relays.

Capacitor C1, at the grid of V1A, limits the high frequency response of this stage and passes to ground any RF signals present at this point. The amplified signal from the plate of V1A is coupled through capacitor C9 to the Microphone Level section of the Mic/CW Level control and also to the VOX amplifier circuit.

The setting of the Microphone Level control determines the amount of modulation since it adjusts the amount of speech signal that is coupled through cathode follower V1B to the balanced modulator circuit. For LSB and USB operation, V1B grid resistor R12 is returned to ground through wafer 1F of the Mode switch and contacts 6 and 10 of relay RL2. When the

Mode switch is in the Tune or CW position, cathode follower V1B is cut off by a bias voltage that is supplied to it from the junction of bias voltage divider resistors R308 and R309.

Carrier Oscillator (Figure 2-7)

The carrier oscillator consists of two Colpitts crystal oscillators. These oscillators supply an RF signal to the balanced modulator for transmit operation, and a heterodyne signal to product detector stage V13 for receive operation. Tube V16A and crystal Y1 (3396.4 kHz) serve as the USB (upper sideband) carrier oscillator, and tube V16B with crystals Y2 (3393.6) and Y3 (3395.4 kHz) acts as the LSB (lower sideband) and CW carrier oscillator.

The desired carrier oscillator, V16B for the transmitted frequency being used in this Description (3393.6 kHz), is placed in operation by wafer 1R of the Mode switch which connects its plate circuit to B+. Wafer 2R of the Mode switch connects the proper crystal to the grid of V16B: Y2 for LSB operation and Y3 for tune or CW transmit operation.

When the Mode switch is in the CW position, B+ is connected through part of relay RL1 to either V16A or V16B.

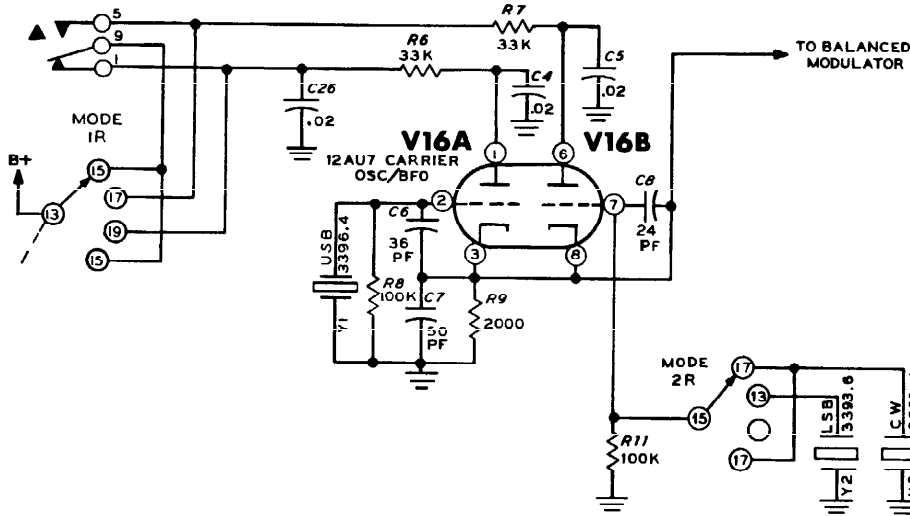

Figure 2-7

V16A

For receiving CW signals, lugs 9 and 1 of relay RL1 place tube (V16B) and crystal Y1 in operation. For transmitting CW, lugs 9 and 5 of relay RL1 place tube V16B and Crystal Y3 in operation.

When receiving CW signals, the receiver is automatically tuned 1 kHz below the incoming signal (this signal is zero beat against your transmitting frequency) by V16A and crystal Y1, which are used as a BFO (beat frequency oscillator). When transmitting, tube V16B and crystal Y3 cause the output signal of the Transceiver to be at the same frequency as the incoming signal from the other station.

Balanced Modulator (Figure 2-8)

Diodes CR1, CR2, CR3, and CR4, are connected in a ring type balanced modulator circuit. When the audio signal from cathode follower V1B and the RF signal from carrier oscillator V16 are applied to this balanced modulator, two additional frequencies are produced: one is equal to the sum of the audio and carrier frequencies; and the other is equal to the difference between them. These sum and difference frequencies are the upper and lower sidebands; and only these upper and lower sideband signals appear at the output of the balanced modulator circuit.

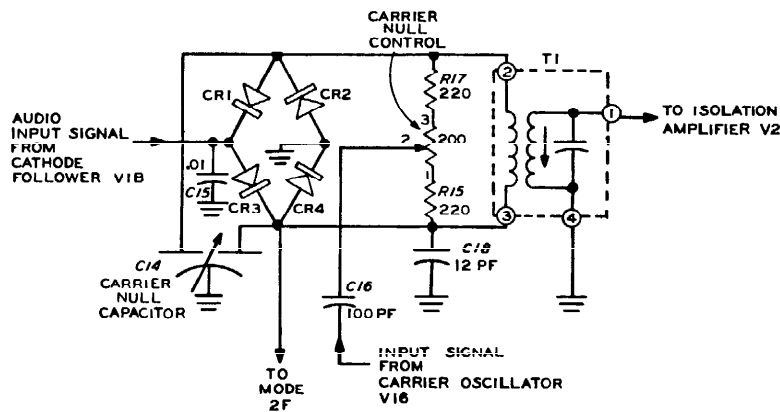

Figure 2-8

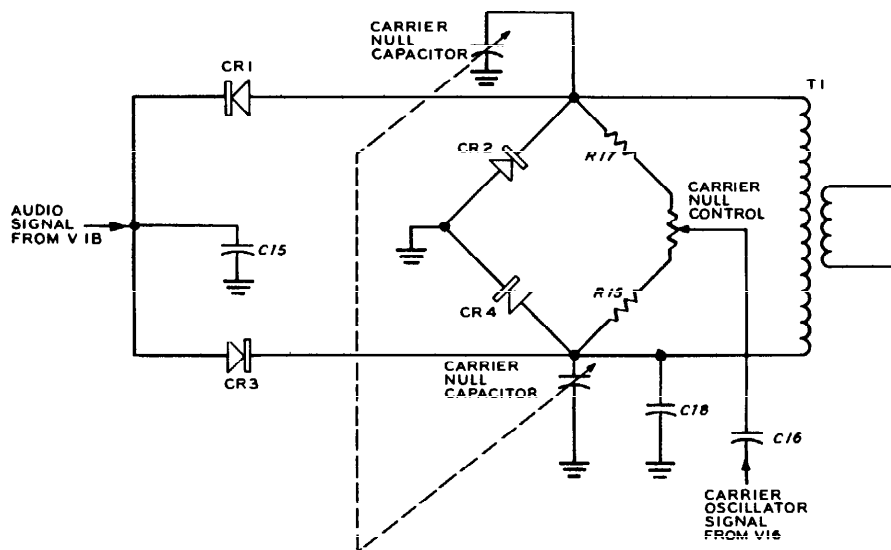
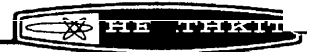

Figure 2-9

The 3393.6 kHz carrier oscillator signal is applied through capacitor C16 and across a bridge circuit that consists of the Carrier Null control, resistors R15 and R17, and diodes CR1, CR2, CR3 and CR4 of the modulator diode ring. See Figure 2-9. The carrier signal is balanced out by the Carrier Null control and the Carrier Null capacitor; so there is no output signal from this circuit (until an audio signal is applied).

The audio signal that is coupled to diodes CR1, CR2, CR3, and CR4 from cathode follower V1B unbalances the modulator at an audio rate, causing the sum and difference sideband frequencies to appear at the output of balanced modulator transformer T1. When no audio signal appears at the input, there is no output signal from the balanced modulator circuit. Capacitor C15 is an RF bypass.

When the Mode switch is turned to the CW position, wafer 2F connects one side of the diode ring to ground. This ground connection unbalances the nulled circuit and the unbalance causes an RF output signal to be produced at the secondary of balanced modulator transformer T1. This signal is then coupled through capacitor C22 to isolation amplifier V2. The secondary of transformer T1 is tuned to the CW carrier frequency.

Isolation Amplifier (Figure 2-10)

Both the upper and lower sideband signals from the balanced modulator circuit are coupled through capacitor C22 to the cathode of isolation amplifier V2. V2 isolates the balanced modulator circuit from the crystal filter, and provides proper impedance matching to the crystal filter. The gain of isolation amplifier V2 is varied by the ALC (automatic level control) voltage that is connected to its grid circuit through resistors R21 and R22. The complete ALC circuit will be described later under the heading ALC Circuit.

When transmitting, the output of V2 is coupled through capacitor C506 to the crystal filter. In the CW mode of operation, the gain of V2 is controlled by the CW section of the Mic/CW Level control. This control supplies a variable negative bias to the grid of V2 through wafer 1R of the Mode switch and resistors R22 and R21.

B+ is supplied to the screen of V2 in the transmit mode only, through resistor R937 and contacts 7 and 11 of relay RL2.

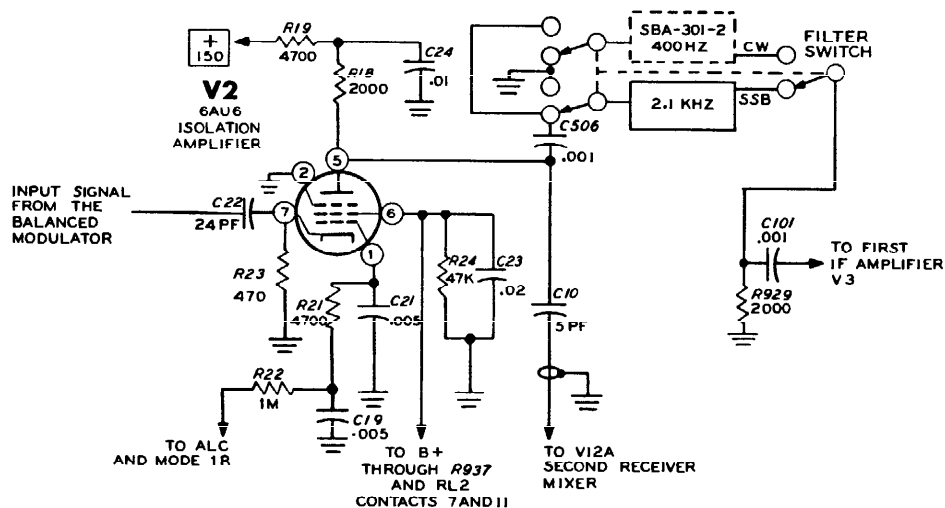

Figure 2-10

Crystal Filter (Figure 2-11)

Crystal filter FL1 has a center frequency of 3395 kHz and a usable bandwidth of 2.1 kHz (3393.95 kHz to 3396.05 kHz at the 6 db points). See Figure 2-11. This filter, in the LSB mode of operation, passes only the sum frequencies (the 3393.6 kHz carrier frequency plus all the audio frequencies from 350 to 2450 Hz), which contain the upper sideband intelligence. The carrier frequency itself, as shown in Figure 2-11, is further reduced 20 db by the crystal filter. This attenuation plus the attenuation of the balanced modulator gives an ultimate carrier attenuation of at least 50 db. (The apparent frequency discrepancy here in sidebands and carrier is overcome later, when the sidebands are inverted in the second mixer.)

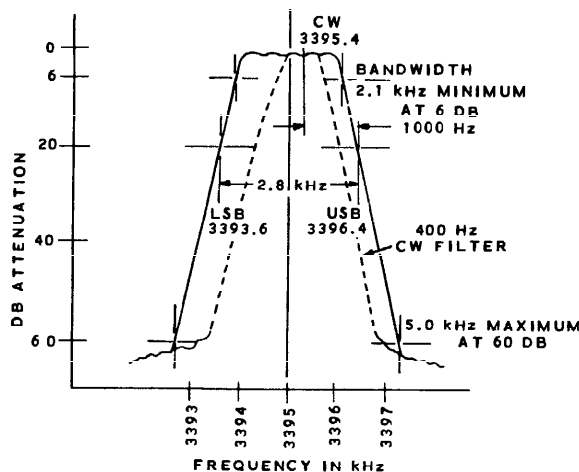

Figure 2-11

USB- 3396,42
 LSB 3393,28

In the USB Mode, the filter passes only the difference frequencies (the 3396.5 kHz carrier oscillator frequency minus the audio frequencies from 350 to 2450 Hz); this contains the lower sideband intelligence. In the CW Mode, a carrier of 3395.4 kHz passes through the crystal filter with no attenuation.

If the SBA-301-2 Accessory CW Crystal Filter is installed, the signal also passes through it when the Filter switch is in CW. The 400 Hz bandpass of the CW Filter will not pass the normal audio range, therefore making SSB signals unintelligible.



Figure 2-12

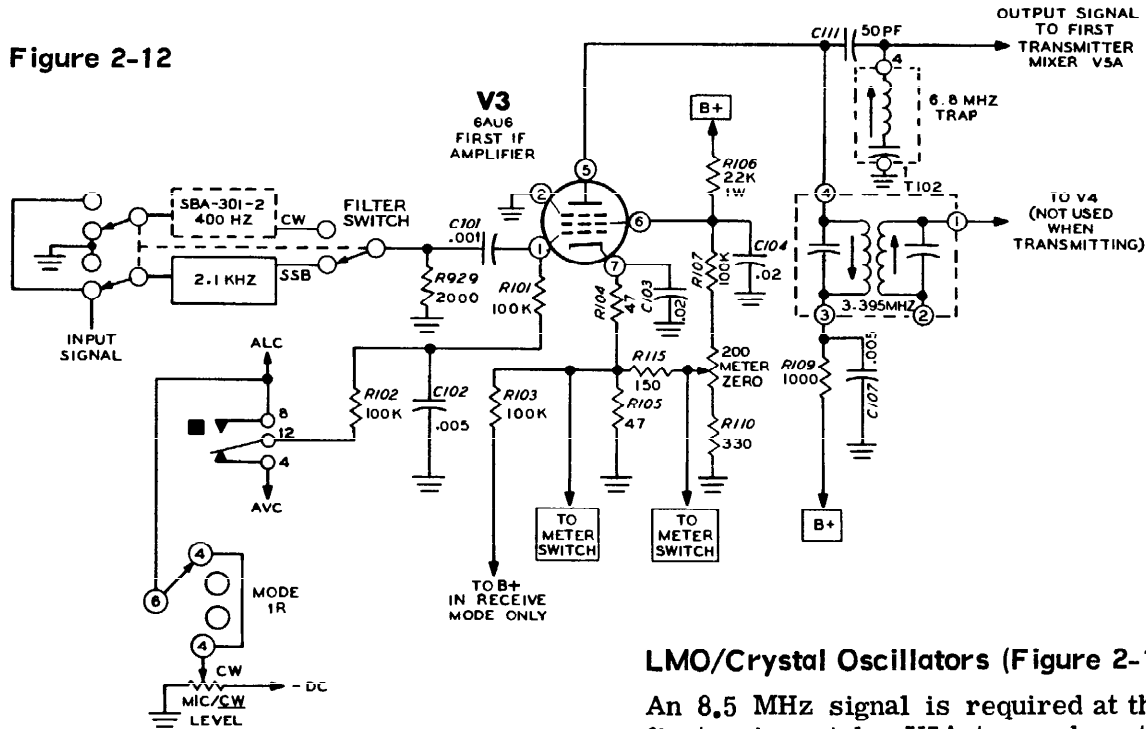

IF Amplifier (Figure 2-12)

IF Amplifier V3 amplifies the signal received from crystal filter FL1. The second IF amplifier, V4, is not used in transmit operation. IF transformer T102, which is tuned to 3,395 mc, acts as the plate load for V3. The output signal from V3 is then coupled through capacitor C111 to the grid of first transmitter mixer stage V5A. The 6,8 MHz trap is used to remove the second harmonic of the 3,395 MHz signal.

ALC voltage is applied through lugs 8 and 12 of relay RL2 to the grid circuit of V3 to provide automatic level control for the transmitted signal. When the Mode switch is in the CW and Tune positions, the gain of IF amplifier V3 is controlled by a variable DC bias applied to its grid. This bias voltage, which originates at the arm of the Mic/CW Level control, is coupled to V3 through wafer 1R of the Mode switch, and through lugs 8 and 12 of relay RL2.

The front panel meter, in the ALC position, is connected in a DC bridge between the screen and cathode circuits of V3. The meter circuits are explained separately on Page 144 of this Circuit Description.

LMO/Crystal Oscillators (Figure 2-13)

An 8,5 MHz signal is required at the output of first mixer tube V5A to produce the correct output frequency on the 3,5 to 4 MHz band, which is being used in this Circuit Description. This 8,5 signal is obtained by mixing the 3,395 MHz IF signal at the grid of V5A with the oscillator signal that is applied to its cathode from the Freq control switch.

The Freq Control switch receives signals from the LMO (linear master oscillator), or from crystal oscillator V5B. The LMO is a very stable variable oscillator that can be continuously tuned linearly over a frequency range of 5 to 5,5 MHz. Crystal controlled Colpitts oscillator V5B may be switched into the circuit in place of the LMO for crystal controlled operation of the Transceiver.

The Freq Control switch performs the following functions: In the LMO position, the signal is connected from the LMO to first transmitter mixer V5A and to first receiver mixer V11. In the Locked AUX position the output of crystal oscillator V5B is connected to first transmitter mixer V5A and to second receiver mixer V12A. In the Unlocked AUX position, the output of crystal oscillator V5B is connected to first transmitter mixer V5A, and the LMO output is connected to second receiver mixer V12A.

The term Locked means that the transmitter and receiver sections are controlled by a common oscillator. This causes them to always be locked on identical frequencies.

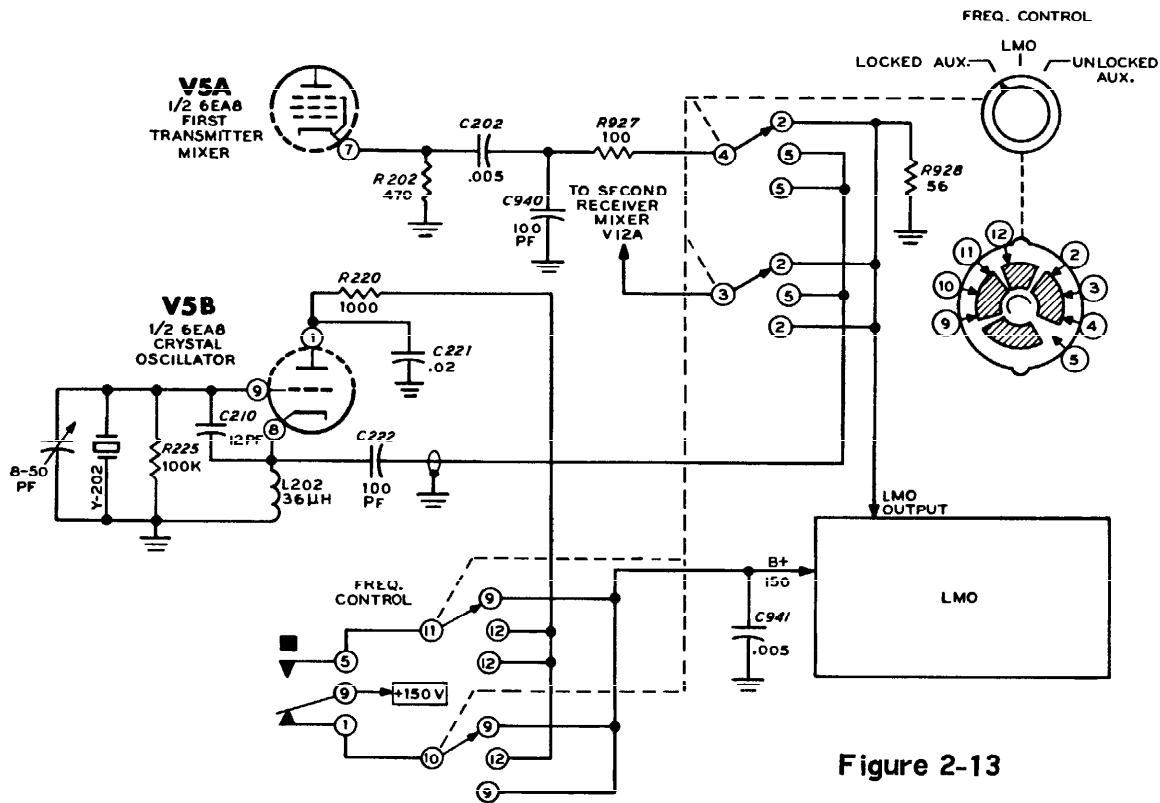

Figure 2-13

The term Unlocked means that the Transmitter and receiver sections are controlled by separate oscillators and their frequencies may differ.

First Transmitter Mixer (Figure 2-14)

The 3.395 MHz IF signal at the grid, and the 5,105 MHz LMO signal (or crystal oscillator signal) at the cathode, are mixed in first transmitter mixer tube V5A to produce sum and difference frequencies. The 8.5 MHz sum of these two signals is coupled from the plate of V5A through bandpass filter T202 to second transmitter mixer V6.

The Bandpass filter T202 is tuned to pass only those signal frequencies between 8,395 and 8,895 MHz; all other frequencies are attenuated. Only the 8.5 MHz sum of the IF and LMO signals falls within this frequency range, so it only is passed on to the second mixer.

First transmitter mixer V5A, second transmitter mixer V6, and driver V7 are cut off during the receive mode of operation by a negative voltage that is applied to their grids through diode D301 and resistor R301. This negative voltage is removed for the transmit mode by contacts 6 and 10 of relay RL2, which cause the cathode side of diode D301 to be grounded.

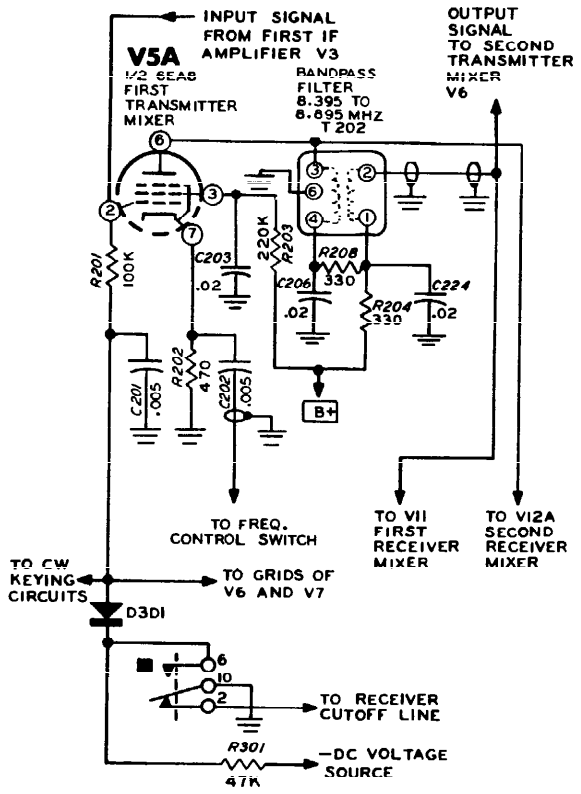

Figure 2-14

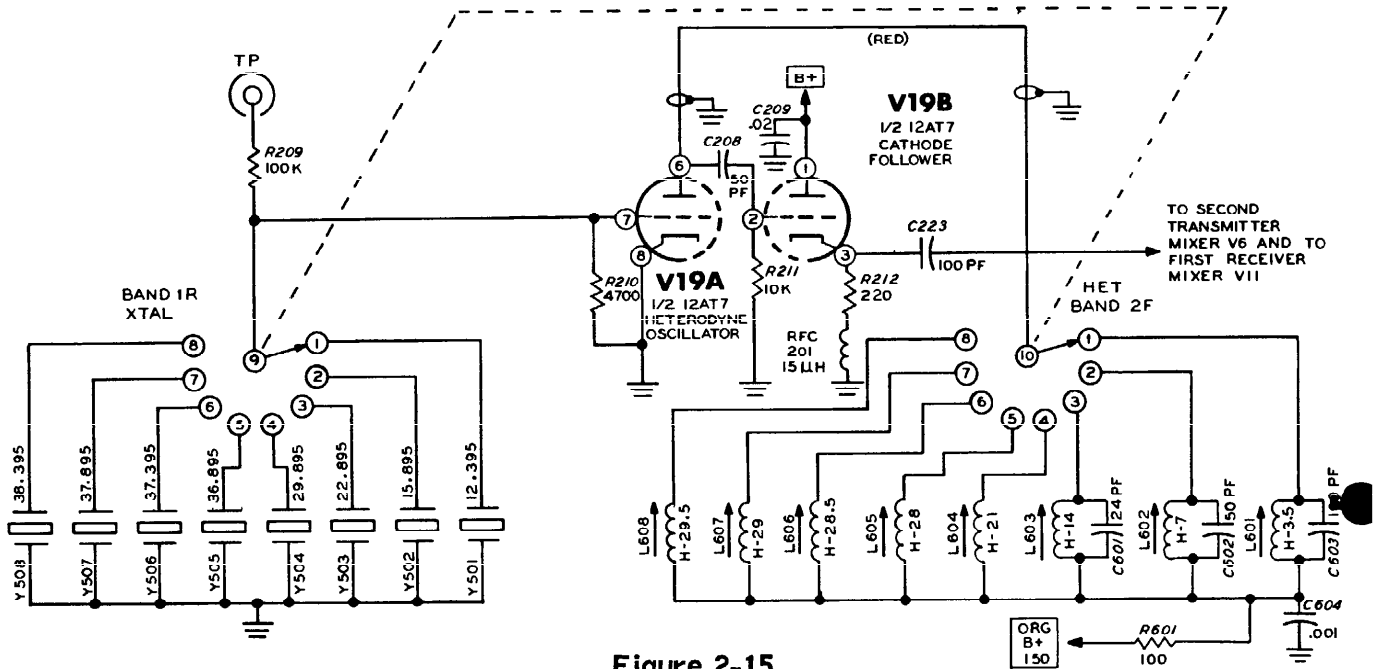

Figure 2-15

Heterodyne Oscillator and Cathode Follower (Figure 2-15)

Heterodyne Oscillator V19A operates as a tuned-plate crystal oscillator. The proper plate coil for each band, L601 through L608, is selected by wafer 2F on the Band switch. The output signal from the plate of the oscillator is coupled through cathode follower V19B to the cathode of second transmitter mixer V6 and to the cathode of first receiver mixer V11. The correct oscillator crystal for each band is selected by wafer 1R of the Band switch. The crystals below 20 mc are fundamental cuts, and the higher frequency crystals operate on their third overtones.

The grid voltage of V19A can be metered at TP to check oscillator activity.

Second Transmitter Mixer (Figure 2-16)

The 8.5 MHz signal from the first transmitter mixer and bandpass filter is coupled to the grid of second mixer tube V6. The 12.395 MHz output from the heterodyne oscillator is coupled to the cathode of V6. These signals are mixed in V6 to produce the operating frequency.

The frequency of the tuned plate circuit of second mixer V6 is the operating frequency. All other frequencies are shorted to ground.

In this instance, the difference between the 8.5 MHz input frequency and the 12,395 MHz heterodyne oscillator frequency results in a second mixer output frequency of 3,895 MHz. This output signal is coupled to the grid of driver stage V7.

The 3.5 MHz plate tuning coil, L701, is connected across the plate tuned circuit on all bands, along with the fixed and variable tuning capacitors. Band switch wafer 3F connects the correct amount of inductance in parallel with L701 to tune each band, except the 3.5 MHz (80 meter) band, which uses coil L701 only.

Tuning capacitor C421B is connected across the tuned circuit on all bands. Tuning capacitor C421A is connected in parallel with C421B on the 80 meter band only, by Band switch wafer 3R.

Driver (Figure 2-17)

Driver stage V7 amplifies the 3.895 MHz signal from second transmitter mixer V6 to a level that is sufficient to drive the final amplifiers.

Final Amplifiers (Figure 2-18)

Final amplifier tubes V8 and V9 are connected in parallel and function as class AB1 linear amplifiers. A fixed negative bias is applied to the grids of these tubes through resistor R916 and choke L903. This bias limits zero-signal plate current. B+ is removed from the screen grids under receive conditions, by lugs 7 and 11 of relay RL2 to reduce the plate current to zero and cut off the tubes. RF driving voltage is developed across RF choke L903. Plate voltage is shunt fed through RF choke L901.

For the LSB and USB modes of operation, the peak driving voltage is controlled by the Microphone level control (in the grid circuit of V1B) and the limiting action of the ALC (automatic level control) voltage. This ALC voltage is fed back to isolation amplifier V2 and IF amplifier V3.

The output signal from V8 and V9 is coupled through RF parasitic chokes L904 and L902 and through capacitor C915 to the final tuning capacitor C925 and plate tank coils L905 and L906. The parasitic chokes eliminate any tendency toward VHF parasitic oscillation.

Wafer 5R of the Band switch connects the proper portion of the plate tank coil in the circuit for each band by shorting out the unused section. Wafer 5R also selects the proper combination of final tank tuning and loading capacitors for each band.

Neutralization of the final amplifier is accomplished by feeding a portion of the plate signal back to the grid through neutralizing capacitors C913 and C914, and across C801 in a bridge circuit.

The output signal from the final tank coil is coupled through lugs 8 and 12 of relay RL1 to the RF Out socket. The antenna switch allows separate transmit and receive antenna circuits to be used, so the Rec Ant socket can be connected to an external relay for use with linear amplifiers that do not have built-in antenna switching.

ALC Circuit (Figure 2-18)

The ALC (automatic level control) bias voltage is developed from a small portion of the signal in the final amplifier stage. This signal is then rectified, filtered, and fed back to the preceding stages to adjust their gain automatically, as needed. ALC voltage assures maximum transmitter output without overloading.

The ALC voltage for this Transceiver is developed in the Heath TALC™ (Triple Action Level Control) circuit. This circuit keeps the transmitter from overloading, without causing the voice peaks to be flat-topped, by compressing the speech waveform. The triple action of this circuit is described below in paragraphs 1, 2, and 3.

1. Any peak voltages at the grids of final tubes V8 and V9 that drive the grids positive into grid current will develop bursts of voltage across resistor R916. This forms an audio-frequency AC that is coupled through capacitor C911 to voltage doubler rectifiers D902 and D903. The rectified negative output voltage goes to the ALC line.
2. The variations that occur in the final amplifier screen supply voltage on speech peaks produce a varying voltage which is coupled through capacitor C908 to rectifiers D902 and D903. This second voltage source produces additional ALC voltage.
3. The ALC voltage that is obtained from an external linear power amplifier can be applied through the ALC connector to rectifiers D902 and D903. With proper conditions, this source should have predominate control, thus holding down the drive in the Transceiver for best operation.

The rectified voltage from diode D903 is applied to an RC network consisting of resistors R914 and R915, and capacitors C931 and C932. This network filters the DC bias voltage, and allows it to build up quickly and decay slowly.

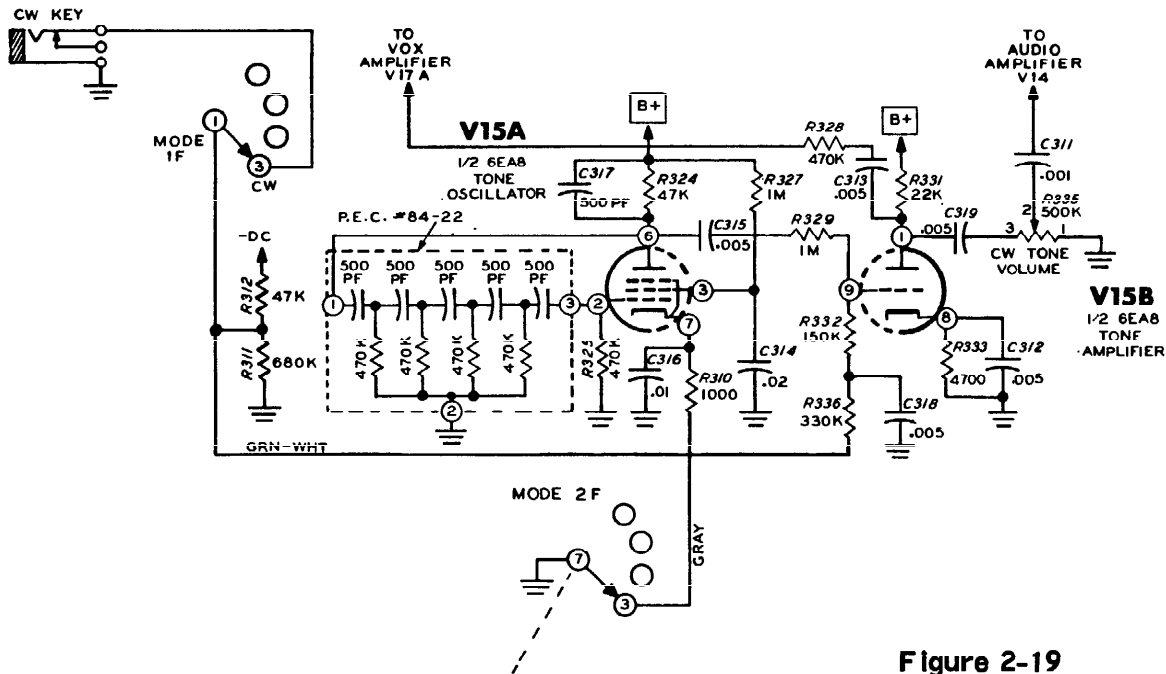

Figure 2-19

From the RC filter network, the ALC voltage is applied to the grid of isolation amplifier V2, where it limits the output, thus reducing the drive available to the final amplifiers. The ALC voltage is also coupled through lugs 8 and 12 of relay RL2 to IF amplifier V3.

ALC voltage is not developed for CW operation. Adjustable bias from the Mic/CW Level control is used instead.

Tone Oscillator and Amplifier (Figure 2-19)

The tone oscillator circuit, V15, generates a 1000 Hz audio signal that is used for CW operation only. This tone is inserted into the VOX circuit to turn on the transmitter. It is also coupled to the receiver audio amplifier so the operator can monitor his transmitted signal.

Tone oscillator V15A is turned on when its cathode is connected to ground through wafer 2F of the Mode switch. The output frequency of V15A is determined by the phase-shift network (P.E.C. #84-22) in its grid circuit. From the plate of V15A, the 1000 Hz tone is coupled through capacitor C315 and resistor R329 to the grid of tone amplifier V15B.

Tone amplifier V15B is normally cut off by a negative bias that is applied to its grid from the junction of resistors R311 and R312. When the CW key is closed, this cut-off bias is removed (resistor R311 is shorted out through Mode switch wafer 1F and the key), and V15B conducts.

From the plate of V15B, the 1000 cps tone is coupled to the CW Tone Volume control, and from there to audio amplifier V14B. The 1000 cps tone is also coupled through capacitor C313 and resistor R328 to the grid of VOX amplifier V17A, where it causes the transmitter to be turned on.

CW Operation

When the Mode switch is turned to the CW position, the following circuit changes occur:

1. Cathode follower V1B is cut off and the arm of VOX Sensitivity control is grounded so stray microphone signals do not reach the balanced modulator or VOX circuits.
2. CW crystal Y3 is connected to the grid of carrier oscillator V16B.
3. The balanced modulator circuit is unbalanced so it will produce an output signal (see Mode switch wafer 2F).
4. The transmitted CW signal will pass through either the Accessory CW Filter or the SSB Filter.
5. The drive to the final amplifiers is controlled by the CW section of the MIC/CW Level control, which adjusts the bias of isolation amplifier V2 and IF amplifier V3.
6. Cut off bias is applied to the grids of transmitter mixers V5A and V6, and to the grid of driver amplifier V7, through Mode switch wafer 1F and diode D904.
7. Tone oscillator V15A is turned on.

When the key is closed, the 1000 Hz tone signal is coupled to the VOX circuit, where it causes the relays to be switched to the transmit position. The relays stay in this position for a length of time that is determined by the setting of the VOX Delay control.

At the same time, the key shorts out the cut-off bias that is applied to the transmitter mixer stages and to the driver amplifier stage, allowing them to conduct and place the transmitter on the air.

The RF output signal from CW carrier oscillator V16B is coupled to the balanced modulator stage. The unbalanced condition of this stage causes the RF signal to be coupled through transformer T1 to isolation amplifier V2. From V2, the signal proceeds through the transmitter in the same manner as the LSB and USB signals.

Switching (Figure 2-20)

Figure 2-20 shows the position and assigns an identifying number to each of the relay section on the main schematic. The numbers will be used in the following paragraphs to explain how each section is used.

1. This section applies B+ voltage to the correct half of carrier oscillator tube V16 in the Tune and CW positions of the Mode switch.
2. This section is connected to the power plug for external use with linear amplifiers and other devices. The contacts have a rating of 3 amperes at 117 VAC or 30 VDC.
3. These contacts apply B+ voltage to the screens of V2, V7, V8, and V9 in the transmit mode, and to the screen of V4, V10 and V11 in the receive mode of operation.
4. These contacts ground out the receiver cut-off bias in the receive mode. In the transmit mode they ground out the cut-off bias that is applied through diode D301 to transmitter stages V5A, V6, and V7.

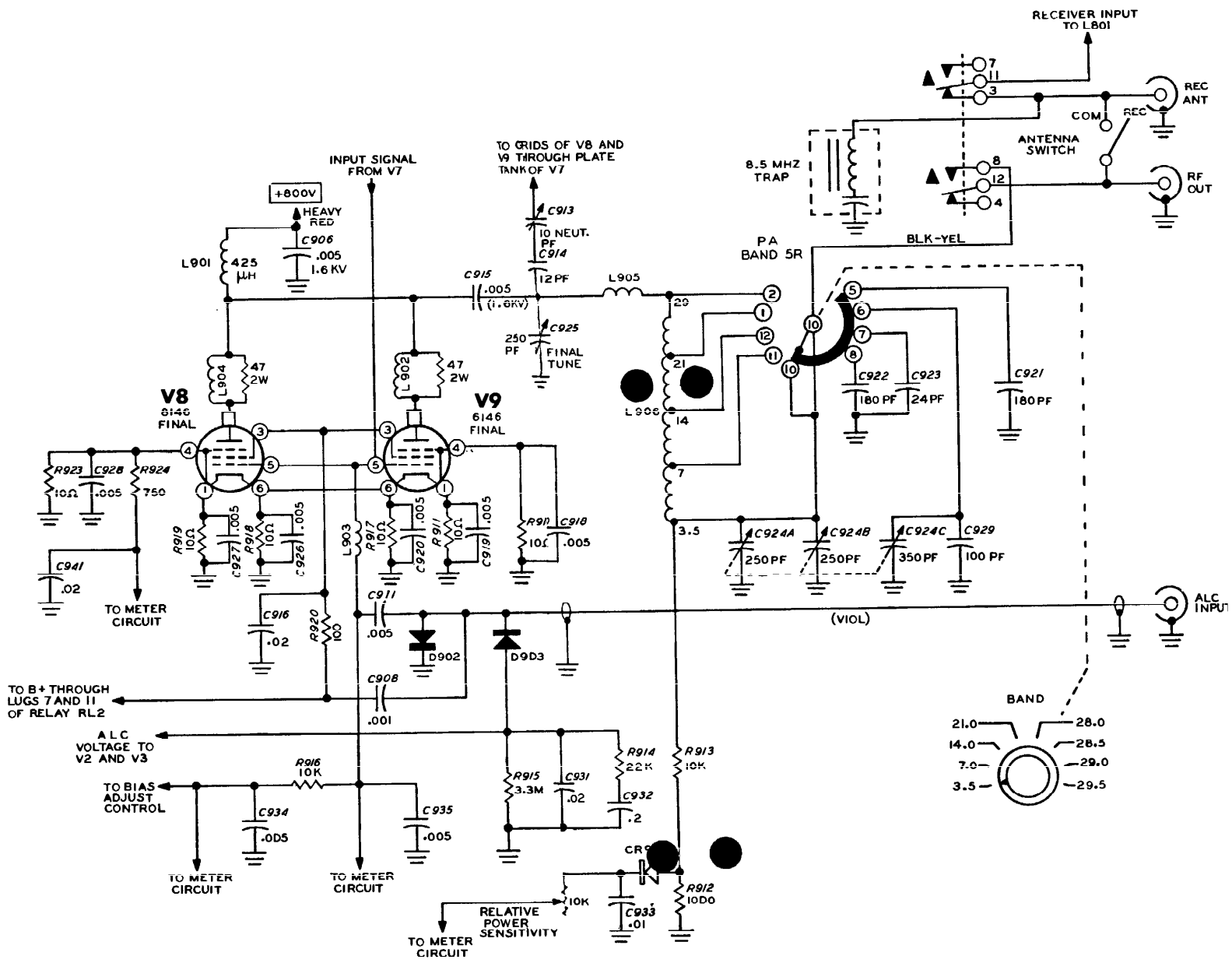

FIGURE 2-18

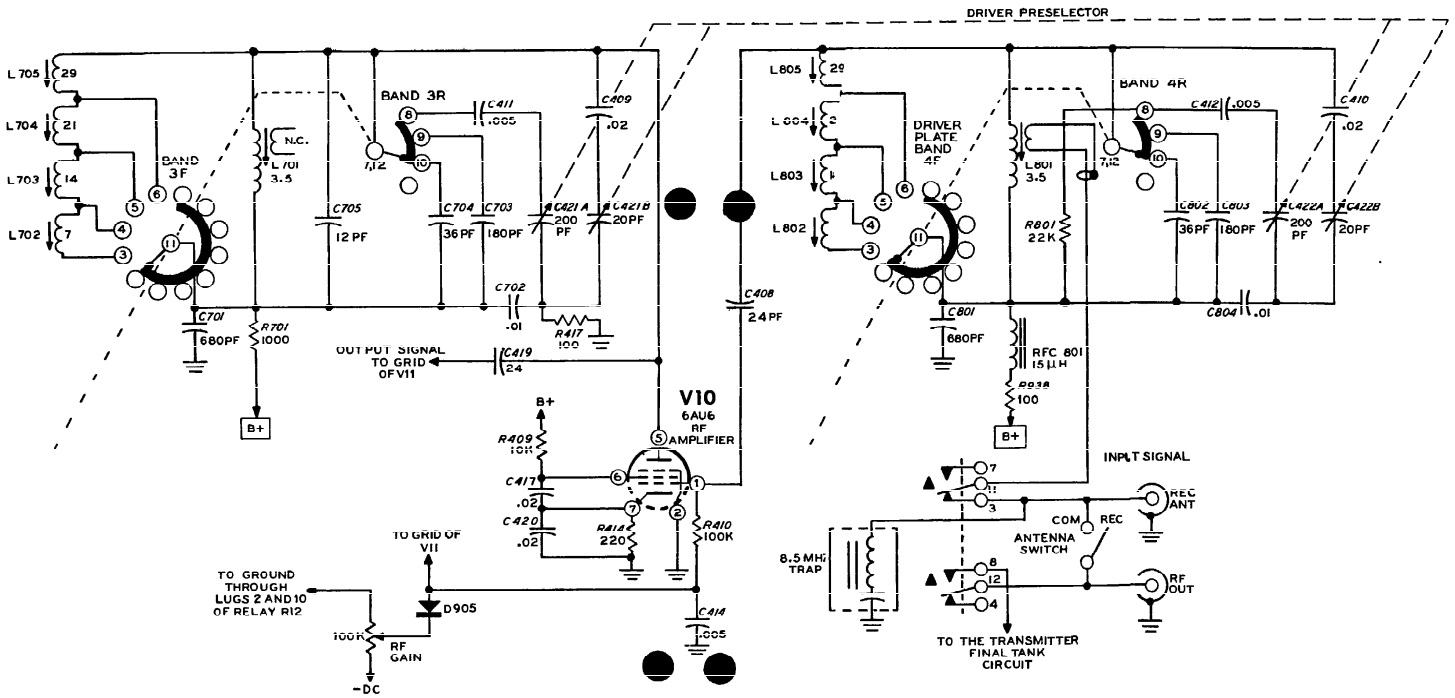

FIGURE 2-22

RELAY POSITIONS

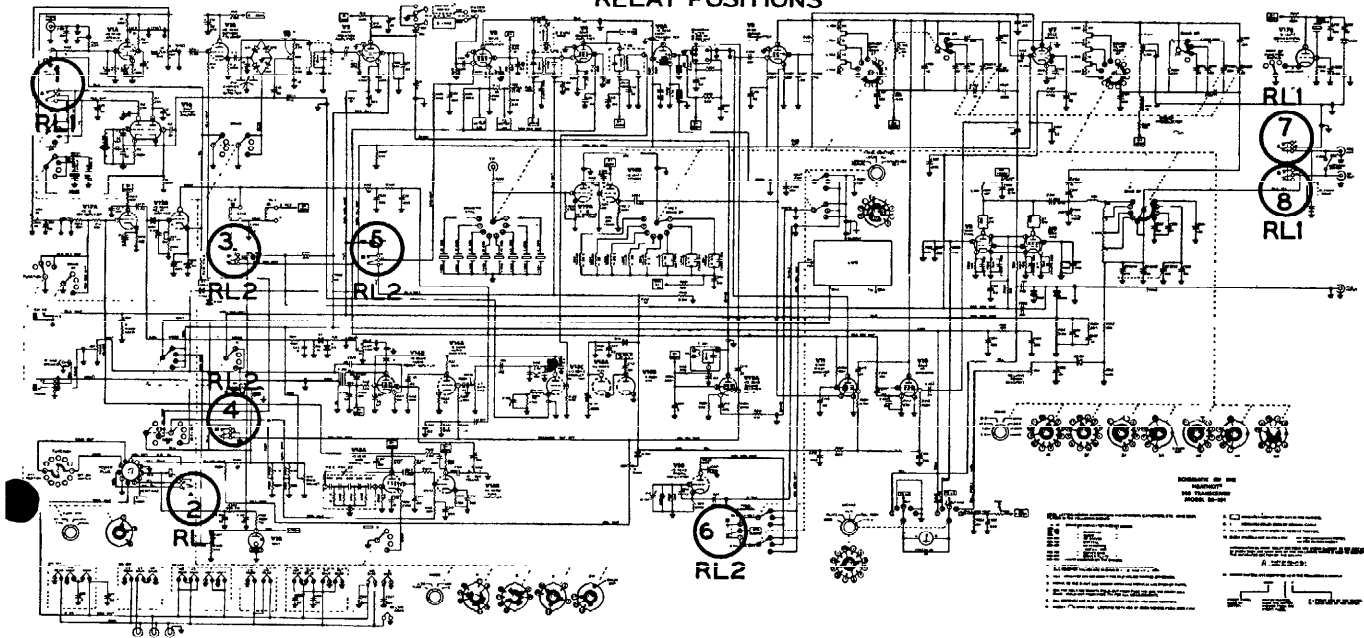

Figure 2-20

5. In the transmit mode, these contacts apply ALC voltage (or CW bias) to the grid of V3. In the receive mode they apply AVC voltage to V3.
6. This section applies +150 V B+ voltage through the Freq Control switch to either the LMO or crystal oscillator V5B.
- 7,8. These contacts switch the antenna between the receive and transmit circuits.

When the Transceiver is in the transmit mode, a large negative bias (approximately -90 volts) is applied through the RF Gain control and diode D905 to the grids of RF amplifier V10, and first receiver mixer V11. Smaller amounts of negative bias are also applied to second receiver mixer V12A, second IF amplifier V4, and audio amplifier V14A. The large bias is necessary at V10 to keep the transmitter signal at the

driver plate from causing V10 to conduct on large voltage peaks. (If this happens, spikes will appear at the peaks of the envelope on the transmitted signal.)

First audio amplifier V14B is cut off by the bias voltage to quiet the receiver audio stages when LSB or USB signals are being transmitted. A negative pulse is also applied to the grid of V14A to cut it off before the relay contacts close. This is done so the switching transients, which cause a "popping" sound, will not be heard in the speaker.

The negative pulse that is applied to V14B is formed by the sudden voltage change that occurs at the plate of relay amplifier V12B when that stage is turned on by the VOX circuit. This pulse is shaped by a network that consists of resistors R337, R338, R339, and R340 and capacitors C320, C321, C322, and C323.

BAND	RECEIVED SIGNAL FREQUENCY	HETERODYNE OSCILLATOR FREQUENCY (CRYSTAL)	SIGNAL FREQUENCY AT BANDPASS FILTER (BETWEEN 8.395 AND 8.895)	2ND RECEIVER MIXER, CRYSTAL FILTER AND IF FREQUENCIES	LMO FREQUENCY (BETWEEN 5 AND 5.5)
3.5 to 4	3.895	12.395	8.5	3.395	5.105
7 to 7.5	7.2	15.895	8.695	3.395	5.3
14 to 14.5	14.2	22.895	8.695	3.395	5.3
21 to 21.5	21.3	29.895	8.595	3.395	5.2
28 to 28.5	28.1	36.895	8.795	3.395	5.4
28.5 to 29	28.7	37.395	8.695	3.395	5.3
29 to 29.5	29.2	37.895	8.695	3.395	5.3
29.5 to 30	29.6	38.395	8.795	3.395	5.4
All frequencies in MHz.					

Figure 2-21

RECEIVER CIRCUITS

NOTE: Figure 2-21 shows the various frequencies that will be found throughout the Transceiver on the different bands. A received signal (lower sideband) frequency of 3.895 MHz, shown on the first line of the chart, will be used when tracing through the receiver circuits. The other associated frequencies used in this Description are also shown on the first line.

RF Amplifier (Figure 2-22, fold-out from Page 138)

The 3.895 MHz input signal from the antenna is coupled through lugs 3 and 11 of the antenna relay (RL1) to the link winding of coil L801. The secondary of L801, part of the Driver Preselector capacitor, and the other components in the driver plate tank circuit, are also used as the input tuned circuit for RF amplifier V10. From L801, the signal is coupled through capacitor C408 to the grid of V10.

The received signal is amplified in V10, and then coupled through capacitor C419 to first receiver mixer V11. The plate tuned circuit of V10 consists of coil L701, part of the Driver Preselector capacitor, and the other components of the second transmitter mixer plate tank circuit.

The gain of RF amplifier V10 and first receiver mixer V11 are controlled by the AVC voltage, and an adjustable negative bias that is coupled to their grids from the RF Gain control.

First and Second Receiver Mixers (Figure 2-23)

The amplified 3.895 MHz signal from RF amplifier V10 is coupled through capacitor C419 to the grid of V11, the first receiver mixer. At the same time, a crystal controlled 12.395 MHz signal is coupled to the cathode of V11 from V19B, the heterodyne oscillator cathode follower. These two signals are then mixed together in V11 and coupled with the sum and difference frequencies to the bandpass filter.

The bandpass filter, which passes only the frequencies between 8.395 and 8.895 MHz, allows the 8.5 MHz difference frequency to pass on from V11 to the grid of second mixer tube V12A.

A 5.105 MHz signal is coupled from either the LMO or crystal oscillator V5B, through the Freq Control switch to the cathode of V12A. The 8.5 MHz signal at the grid and the 5.105 MHz signal at the cathode are then mixed together in tube V12A and the 3.395 MHz difference frequency is coupled through crystal filter FL1 to the IF amplifiers.

The Filter switch selects either crystal filter FL1 for SSB use or FL2 for CW use. Crystal filter FL1 sets the IF bandwidth at just 2.1 KHz wide (see Figure 2-11 on Page 131). This narrow, steep sided passband permits good selectivity for SSB reception in crowded amateur bands. Crystal filter FL2 can be switched in for CW reception. FL2 sets the IF bandwidth at just 400 Hz wide. This narrow bandwidth is good for CW reception only.

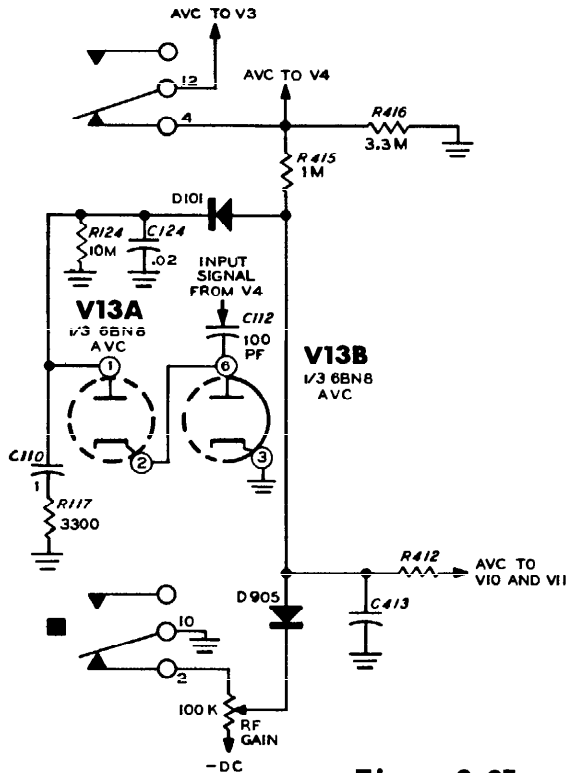

Figure 2-25

AVC Circuit (Figure 2-25)

The negative bias at the control grids determines the amount of amplification that will be obtained from RF amplifier V10, first receiver mixer V11, and IF amplifiers V3 and V4. The DC bias for these stages comes from the following two sources: from the -DC voltage at the arm of the RF Gain control; and from the AVC voltage. These two voltage sources are connected to diodes D101 and D905, which act as a diode gate. This diode gate permits either voltage to control the gain (of V10, V11, etc.) without interacting with each other.

From this point, the bias voltage is coupled through resistor R412 to the grids of V10 and V11, and through resistor R415 to the grids of V3 and V4. Voltage divider resistors R415 and R416 cause only one half of the total bias voltage to be coupled to the grids of IF amplifiers V3 and V4.

AVC voltage is obtained by coupling part of the IF signal through capacitor C112 to AVC diodes V13A and V13B. These diodes produce a negative DC voltage at pin 1 of V13A that is proportional to the signal strength. This negative voltage is developed across resistors R124 and R117, and capacitors C110 and C124. Capacitor C124 charges quickly to the peak voltage so the AVC will respond quickly to keep large signals from being distorted in V3, V4, V10, and V11. Capacitor C110 charges more slowly, and causes the AVC voltage to be proportional to the average signal level of the received signal. This produces a fast-attack, slow-release AVC characteristic.

An incoming signal that produces a negative AVC voltage that is significantly higher than the bias voltage from the RF Gain control causes the gain of V10, V11, V3, and V4 to be reduced. This keeps the output of the RF and IF amplifier stages at a nearly constant level despite wide amplitude changes in the received signal.

Product Detector (Figure 2-26)

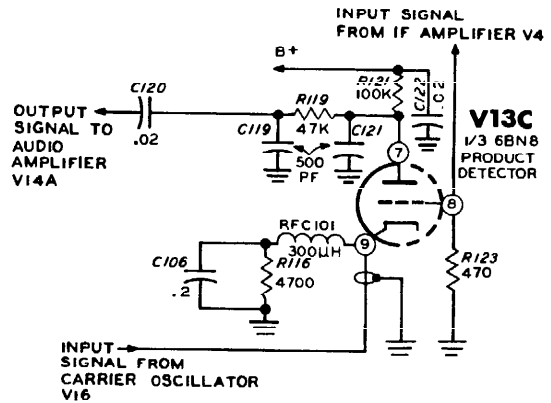

Figure 2-26

The 3.395 MHz signal from IF amplifier V4 is coupled to the grid of product detector tube V13C. At the same time, the signal from carrier oscillator V16 is fed to the cathode of V13C (3.3936 MHz for the lower sideband, or 3.3964 MHz for the upper sideband). These two signals are then mixed together in V13C, resulting in an audio output signal which is the

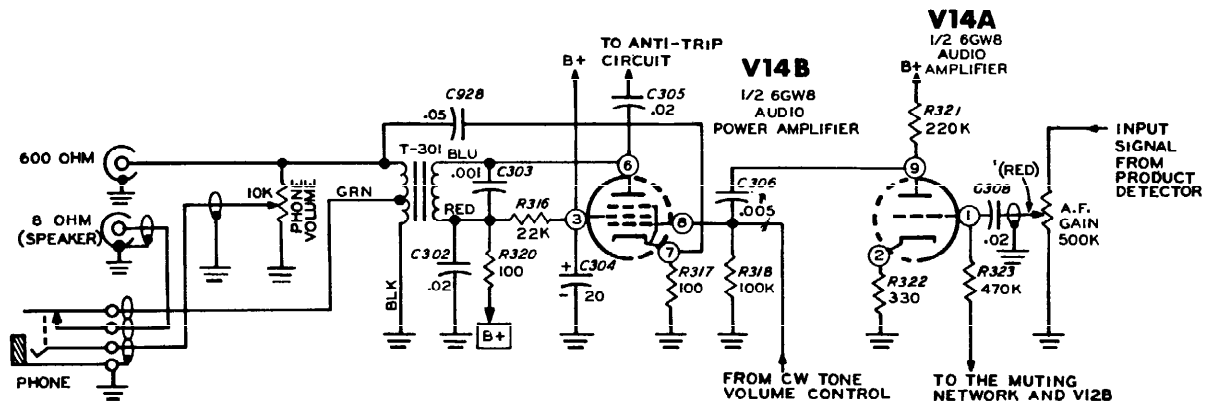

Figure 2-27

difference frequency between these two signals. Capacitors C119 and C121, and resistor R119 are connected in a filter network that bypasses any RF signal coming from V13C to ground, but permits the audio signal to pass through to audio amplifier V14A.

Audio And Power Amplifier (Figure 2-27)

The signal from the product detector is applied to the AF Gain control to determine the amount of signal that will be coupled through capacitor C308 to the grid of audio amplifier V14A. The audio signal is amplified in V14A and then coupled to power amplifier V14B. Tube V14B amplifies the signal further and supplies the audio power through output transformer T301 to the output connectors. Capacitor C928 couples a portion of the output back to the cathode of V14B as negative feedback for less distortion.

Three outputs are provided by the secondary of transformer T301: a headphone output, a 600 Ω output, and an 8 Ω speaker output. Audio power to the 8 Ω speaker jack is rated at 2 watts maximum.

An audio signal is also supplied to the anti-trip network from the plate of V14B.

CRYSTAL CALIBRATOR (Figure 2-28)

Crystal calibrator stage V17B is connected as a Pierce crystal oscillator. When the Function switch is placed in the Calibrate position, the

cathode of V17B is grounded, and an accurate 100 kHz signal is connected through capacitor C218 and diode CR201 to the antenna input of the receiver. The harmonics of this signal are then used for dial calibration checks.

Calibrate Crystal capacitor C220 may be adjusted to set the crystal calibrator to exactly 100 kHz using some standard such as WWV.

The Calibrate position of the Function switch also connects the grid of VOX amplifier V17A to ground to avoid accidental energizing of the transmitter when using the crystal calibrator.

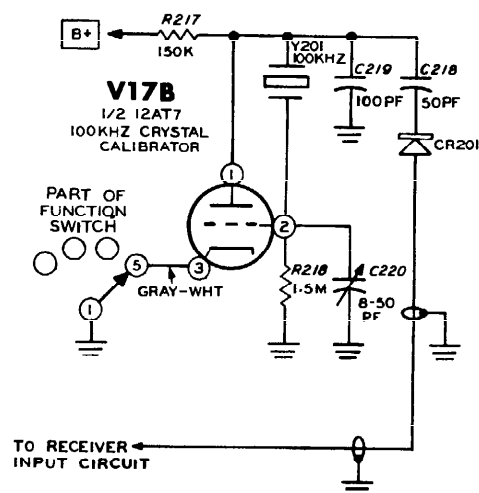

Figure 2-28



METERING CIRCUITS (Figure 2-29)

For the transmitting mode of operation, there are five different settings of the Meter switch: final Grid current, final Plate current, ALC voltage, Relative Power output, and High Voltage. In the ALC position, in the receive mode, the meter operates as an S-Meter.

To measure the grid current for final amplifiers V8 and V9, the meter is shunted across resistor R916 in the grid circuit of these tubes. The meter will then read from 0 to 1 ma of grid current.

To measure final amplifier plate current, the meter is connected between the cathodes of the finals and ground, in parallel with the cathode resistors. Plate current can then be read on the 0 to 500 ma range of the meter.

To measure ALC voltage, the meter is connected between the cathode and screen circuits of IF amplifier V3. The meter zero control is adjusted for zero current flow through the meter with no signal input. When V3 receives a signal, the resulting current fluctuations in the cathode are indicated on the meter. Since the ALC voltage at the grid controls the gain of V3, the cathode current of V3 gives a relative indication of the ALC voltage level.

For Relative Power measurements, a small portion of the transmitter output signal is developed across resistor R912, rectified by diode CR901, and filtered by capacitor C933. The resulting DC voltage, is then indicated by the meter. The Relative Power Sensitivity control allows the operator to set his full power output indication at a convenient meter reading.

The high voltage is brought down to a measurable level by a precision multiplier resistor, R921. 0-1000 volts can be read on the 0-10 scale of the meter. Resistor R922 keeps the open circuit voltage at a safe level when the Meter switch is in other positions.

When the Transceiver is in the receive condition, and the Meter switch is at ALC, the meter indicates the relative strength of the received signal in S-units. The circuit operates just as it does when it measures ALC voltage, except that the current in V3 is now controlled by the AVC voltage at the grid of V3.

The Meter Zero control is adjusted for a zero indication on the meter with the antenna disconnected and RF Gain control at the full clockwise position. The decrease in plate current (due to a larger AVC voltage) that occurs when a signal is received by tube V3 then appears as indications on the S-Meter.

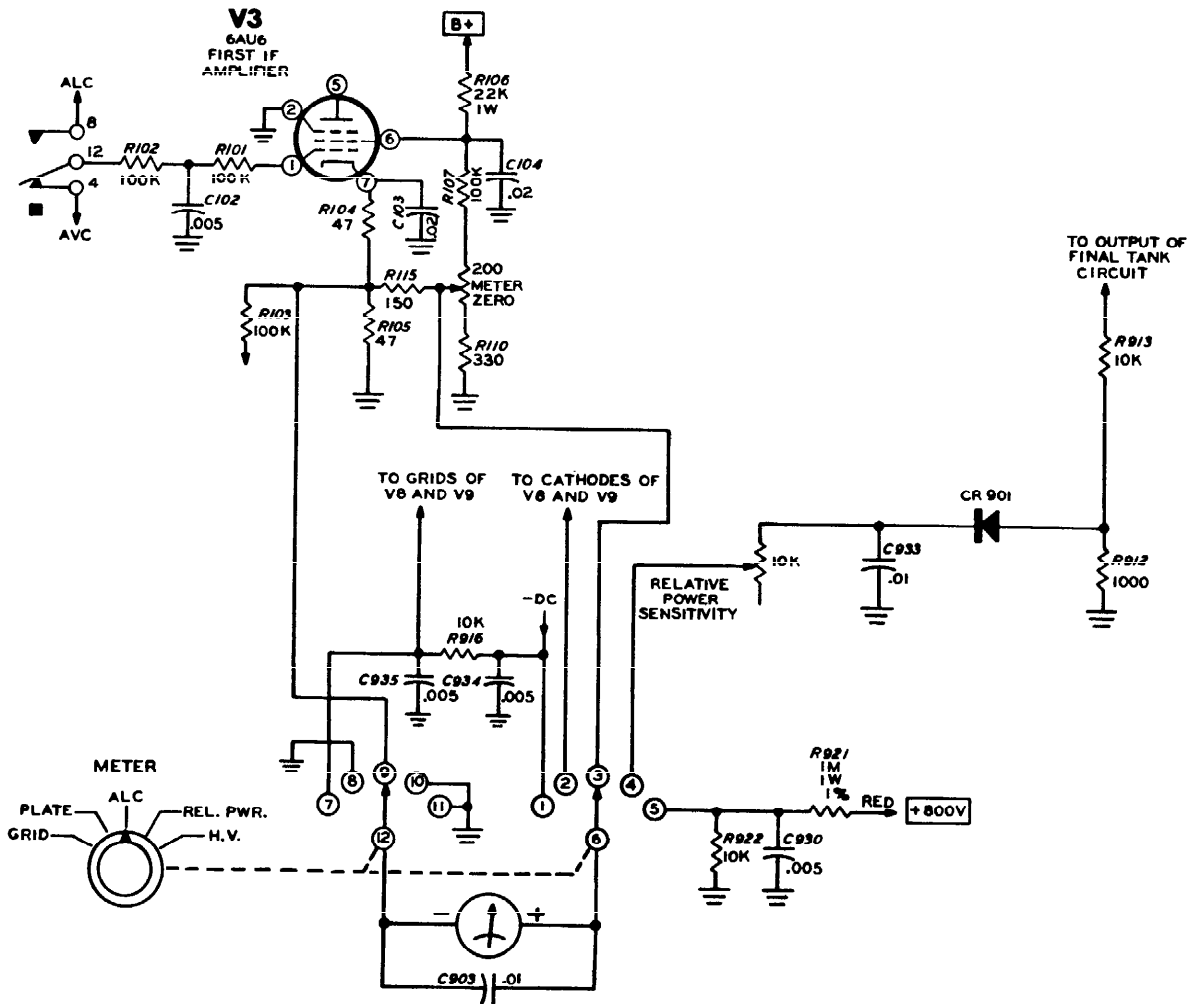
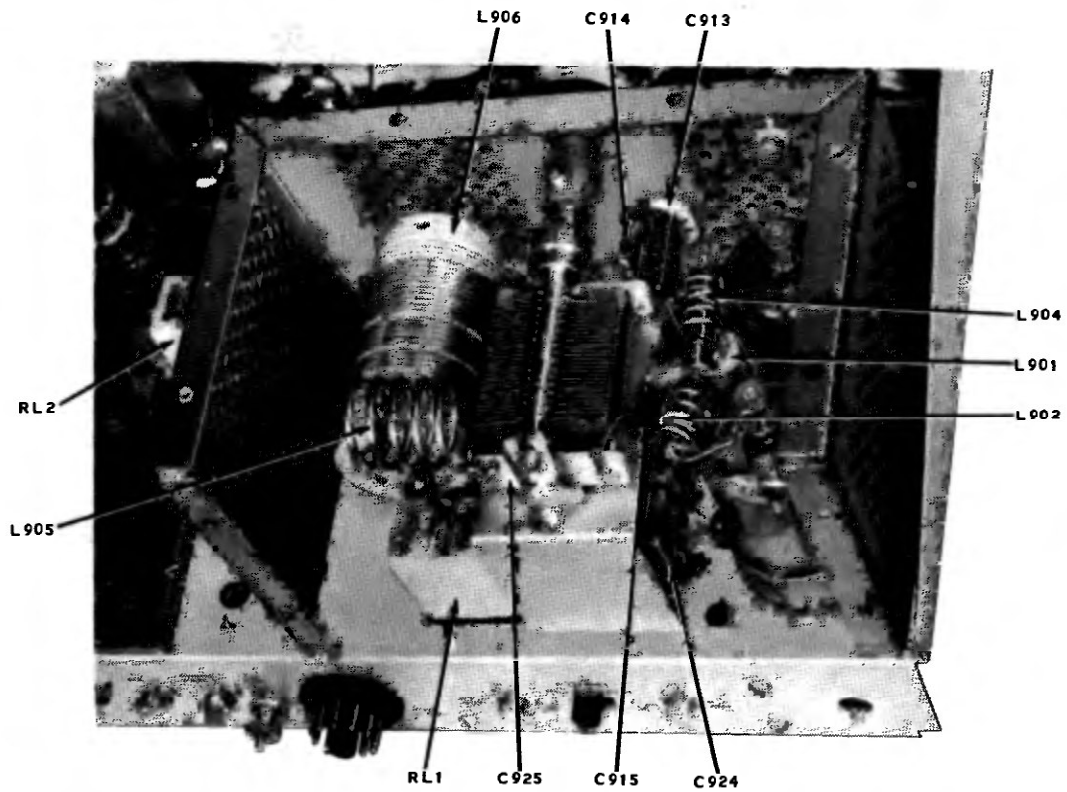
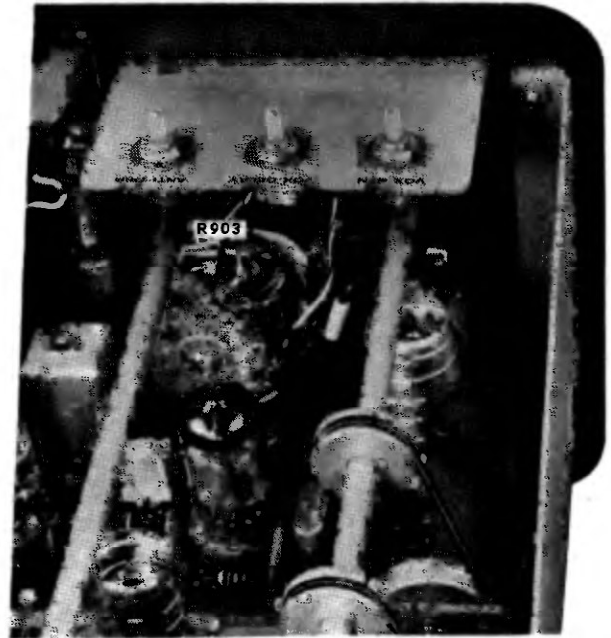
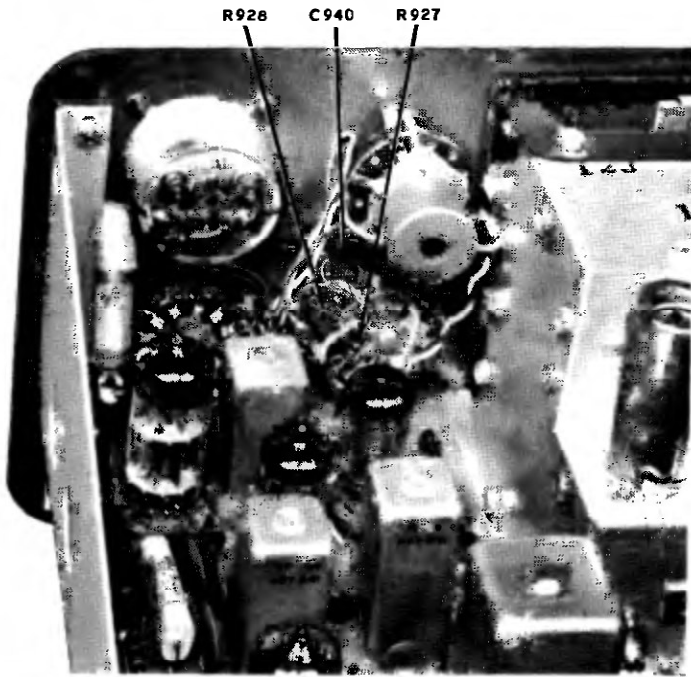
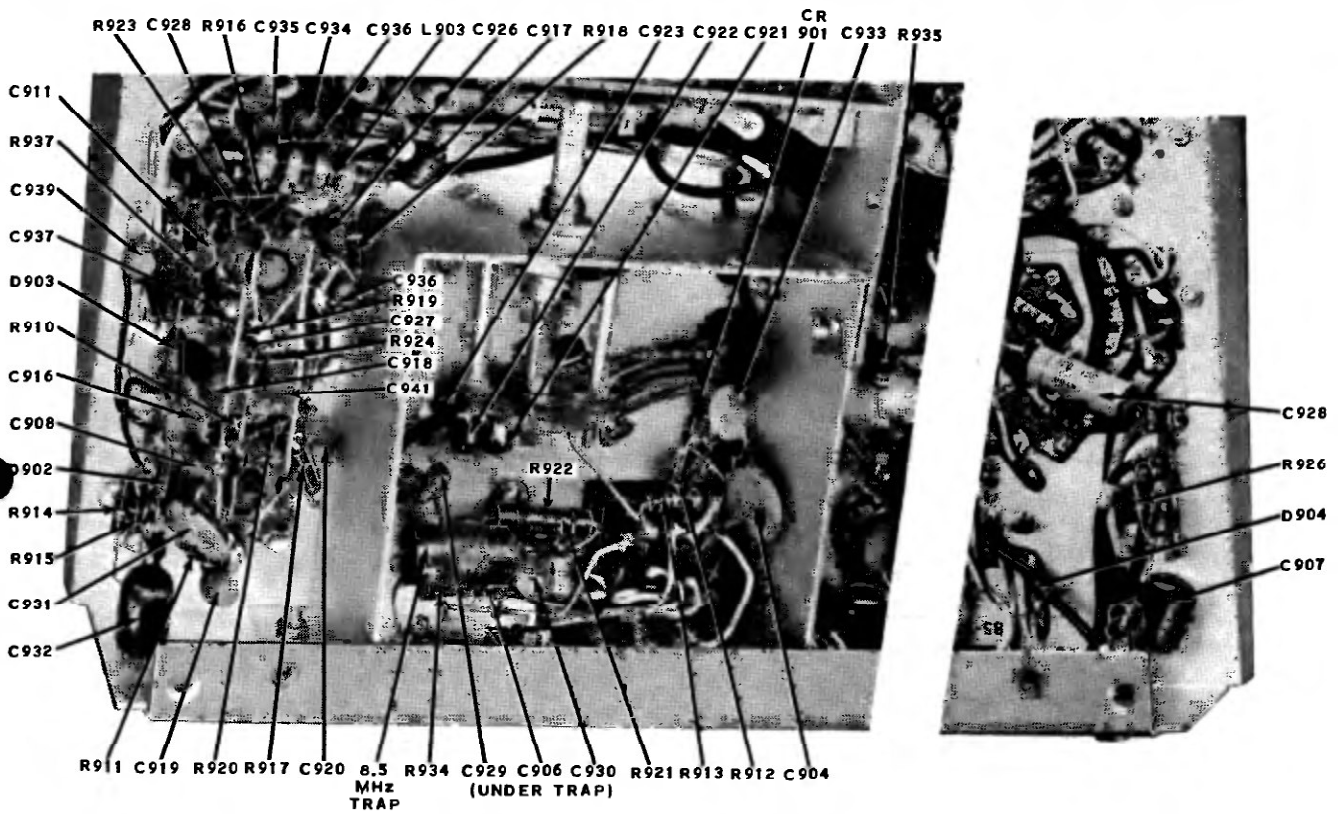
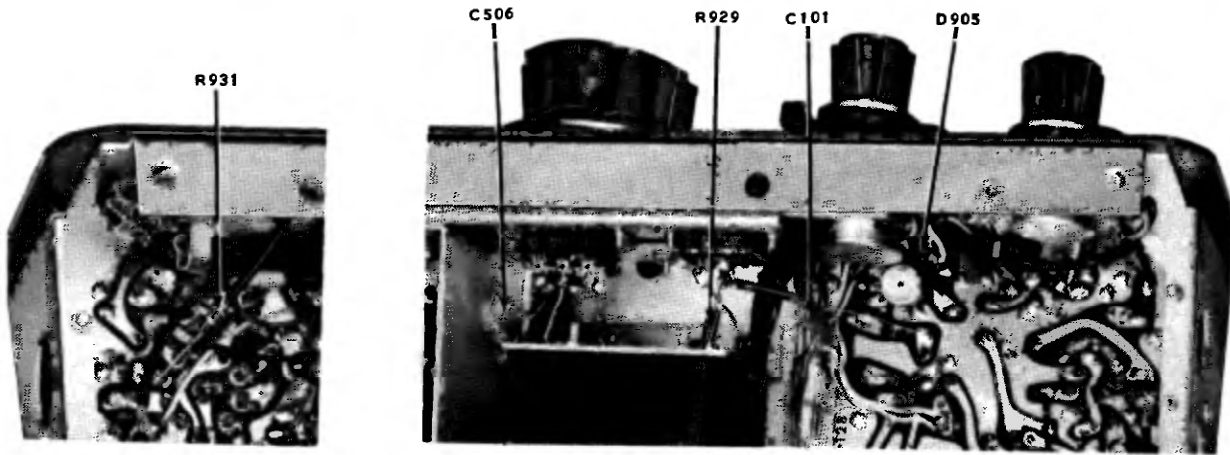

Figure 2-29

CHASSIS PHOTOGRAPHS



TOP VIEW



BOTTOM VIEW

CIRCUIT BOARD X-RAY VIEWS (VIEWED FROM FOIL SIDE)

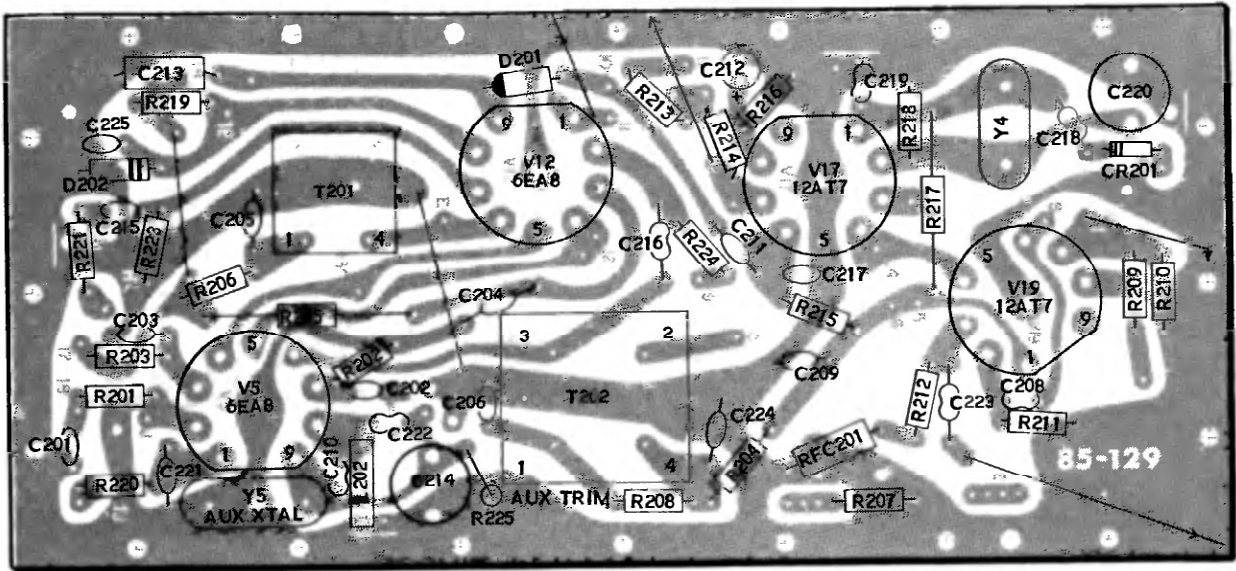

BANDPASS CIRCUIT BOARD
#85-129-2

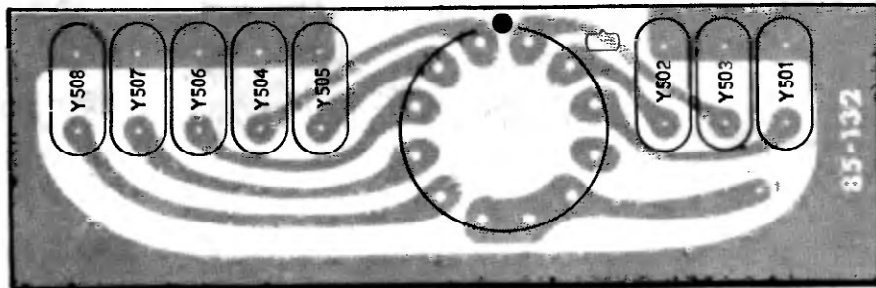

CRYSTAL CIRCUIT BOARD
#85-132-1

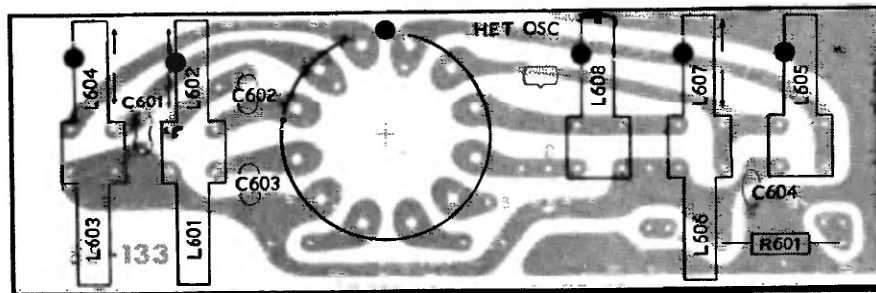

HETERODYNE OSCILLATOR CIRCUIT BOARD
#85-133-1

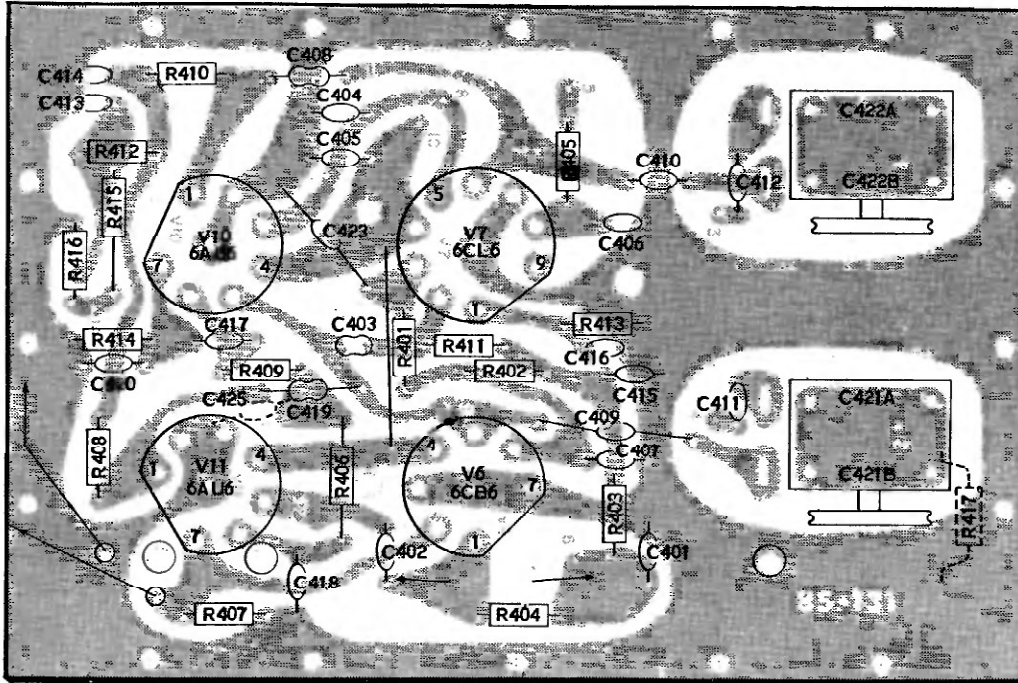

RF-DRIVER CIRCUIT BOARD
#85-131-1

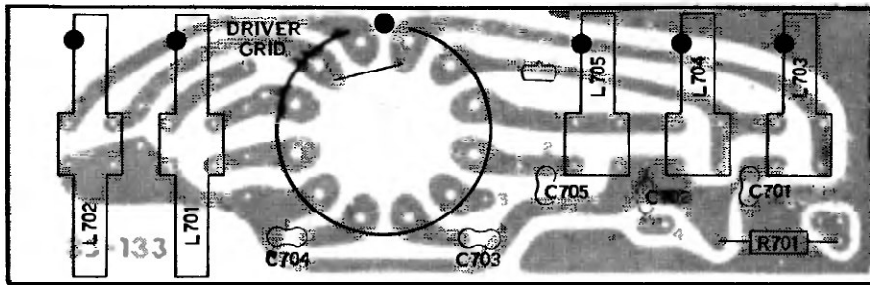

DRIVER GRID CIRCUIT BOARD
#85-133-2

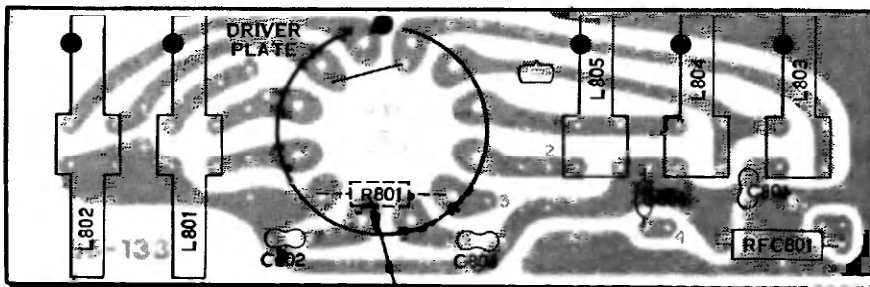

THIS RESISTOR LOCATED
ON SWITCH WAFER.

DRIVER PLATE CIRCUIT BOARD
#85-133-3

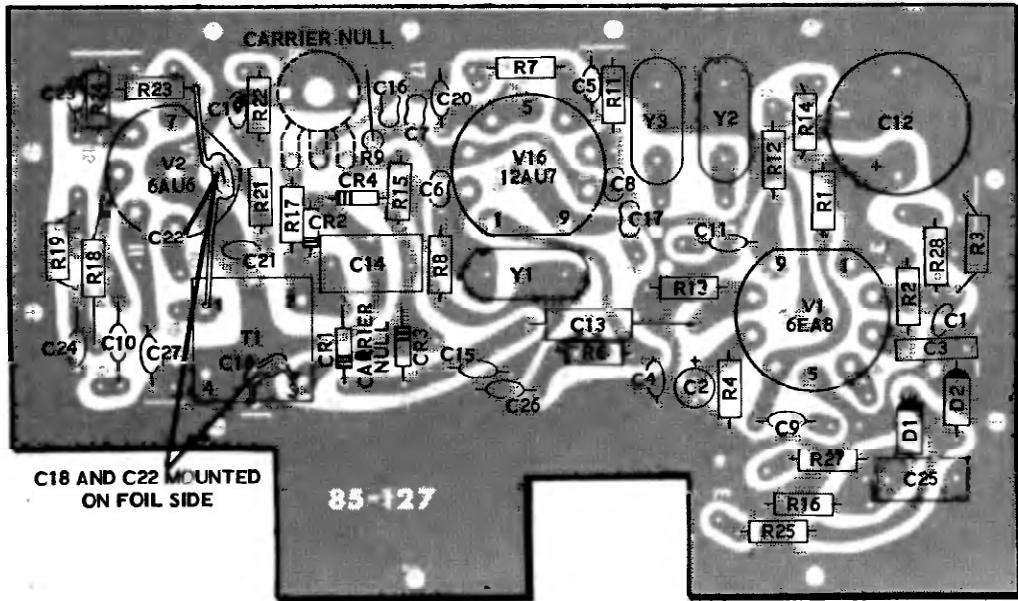

MODULATOR CIRCUIT BOARD
#85-127-1

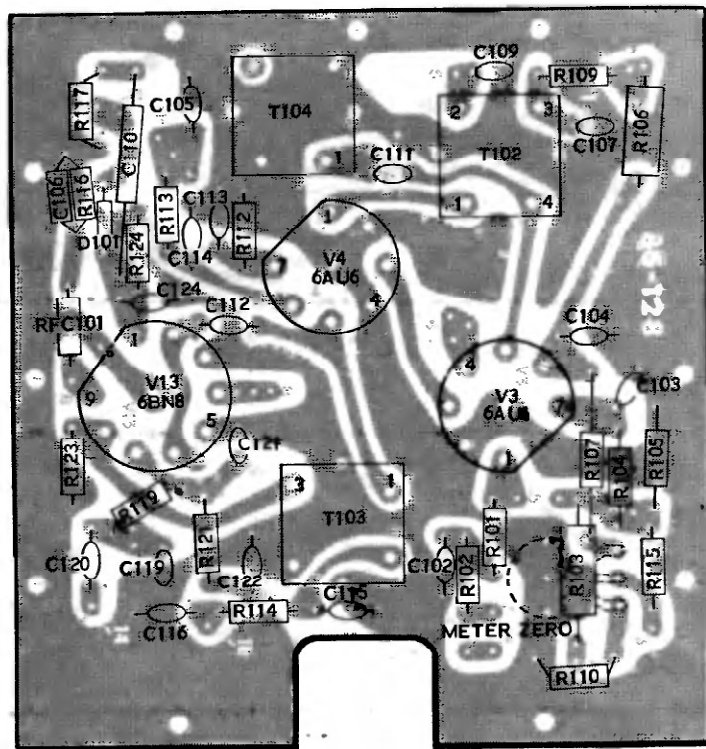

IF CIRCUIT BOARD
#85-128-2

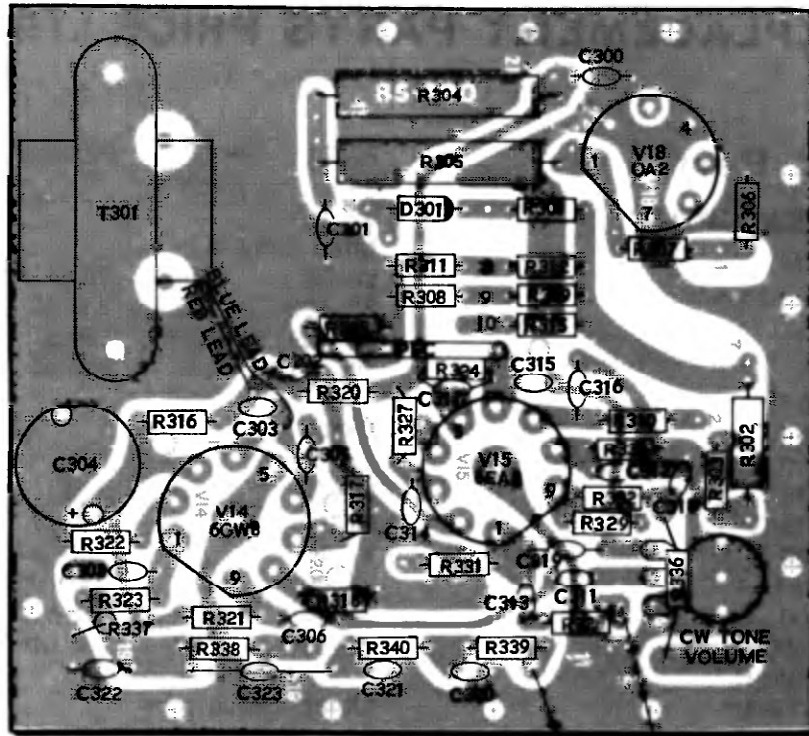

AUDIO CIRCUIT BOARD
#85-130-1

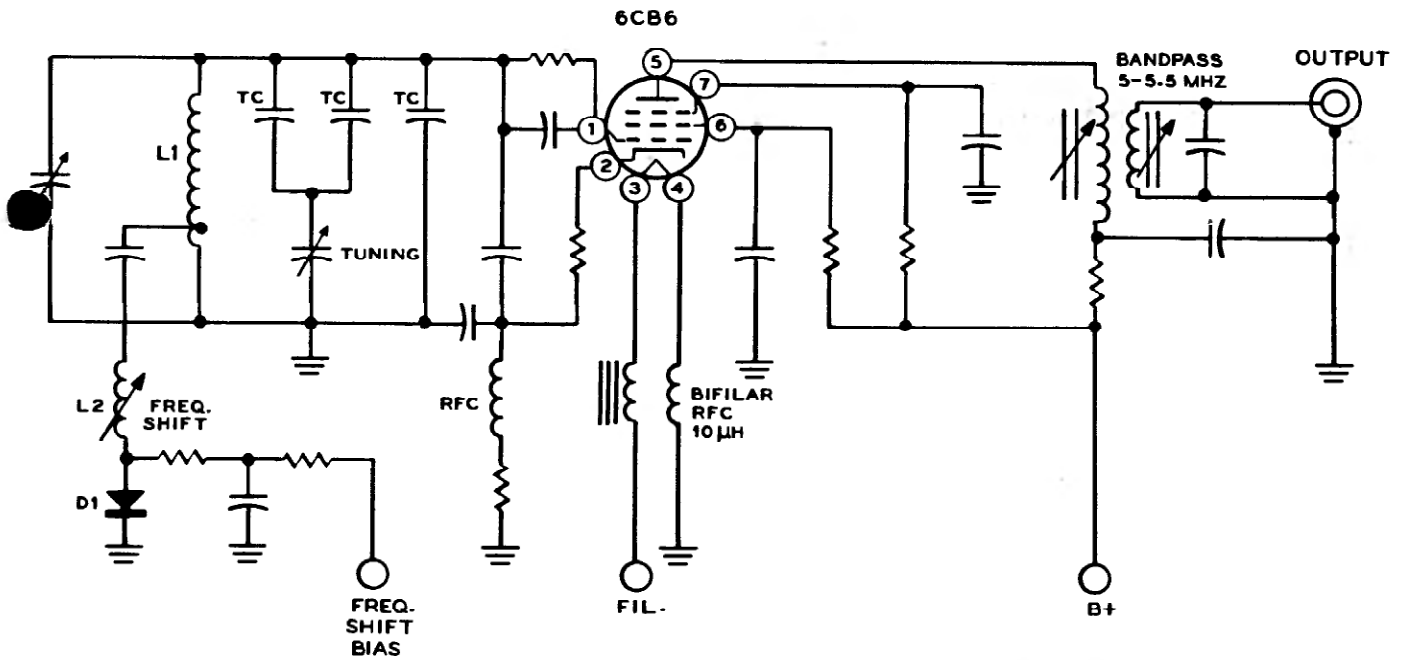

LMO SCHEMATIC

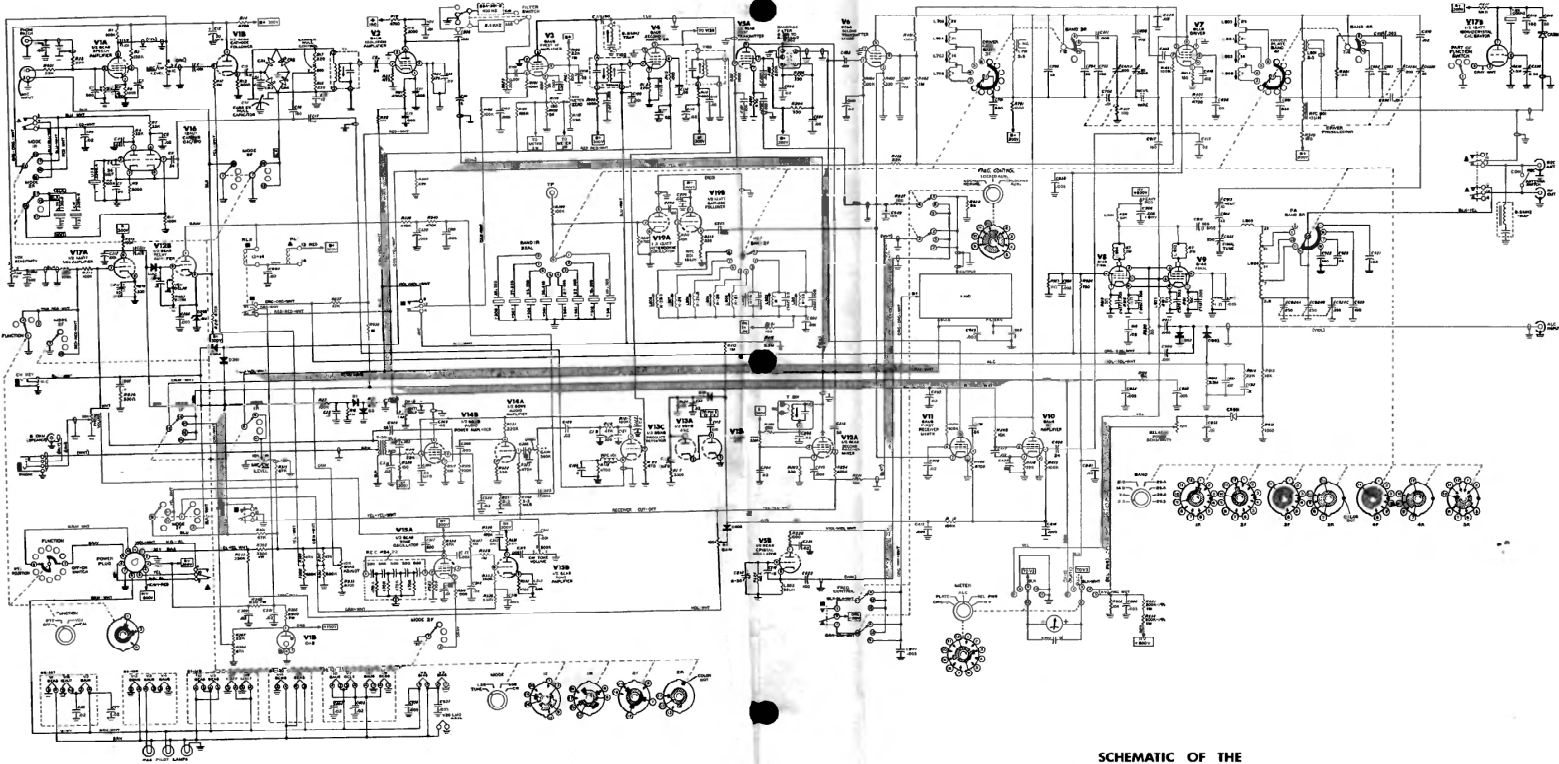

**SCHEMATIC OF THE
HEATHKIT®
SSB TRANSCEIVER
MODEL SB-101**

NOTE: LETTER-NUMBER DESIGNATIONS FOR RESISTORS, CAPACITORS, ETC., HAVE BEEN PLACED IN THE FOLLOWING GROUPS:

- | | |
|---------|-----------------------------------|
| 0 - 99 | PARTS ON MODULATOR CIRCUIT BOARD. |
| 100-199 | " |
| 200-299 | " |
| 300-399 | BANDPASS |
| 400-499 | AUDIO |
| 500-599 | RF-DRIVER |
| 600-699 | CRYSTAL |
| 700-799 | HETERODYNE |
| 800-899 | OSCILLATOR |
| 900-999 | DRIVER PLATE |
| 000-999 | PARTS MOUNTED ON THE CHASSIS. |

1. ALL RESISTORS ARE 1/2 WATTY UNLESS MARKED OTHERWISE. ALL RESISTOR VALUES ARE IN OHMS (K - 1000, MEG - 1,000,000).
2. ALL CAPACITOR VALUES OVER 1 ARE IN μ UNLESS MARKED OTHERWISE.
3. REFER TO THE X-RAY AND CHASSIS VIEWS FOR PHYSICAL LOCATION OF PARTS.
4. SEE THE VOLTAGE CHARTS (FOLD-OUT FROM PAGE 112) AND THE RESISTANCE CHART (FOLD-OUT FROM PAGE 113) FOR ALL MEASUREMENTS.
5. ALL SWITCHES ARE IN THE POSITION INDICATED BY THE KNOB POINTERS.
6. ARROW (\curvearrowright) INDICATES CLOCKWISE ROTATION OF KNOB (VIEWED FROM KNOB END).

7. \square INDICATES HOOKUP WIRE NOT IN THE HARNESS.
8. () INDICATES COLOR CODE OF COAXIAL CABLE.
9. ALL RELAY CONTACTS SHOWN IN RECEIVE POSITION.
10. DIODE SYMBOLS ARE AS FOLLOWS: $\text{—}|$ FOR GERMANIUM DIODES. $\text{—}|$ FOR SILICON DIODES.
11. FOR GREATER CLARITY, RELAY SECTIONS ARE SHOWN CLOSEST TO THE CIRCUITS IN WHICH THEY ARE USED. ONE OF THE FOLLOWING MARKS IS USED TO IDENTIFY THE SEPARATED SECTION OF THE RELAYS:
 \triangle = PART OF RELAY RL1
 \square = PART OF RELAY RL2
12. SWITCH WAFERS ARE IDENTIFIED AS IN THE FOLLOWING EXAMPLE:

FRONT PANEL NAME OF SWITCH. WAFER NUMBER WITH THE SWITCH VIEWED FROM THE FRONT PANEL. F - FRONT SIDE OF THE WAFER. R - REAR SIDE OF THE WAFER.



REPLACEMENT PARTS PRICE LIST

Circuit Board Parts

PART No.	PRICE Each	DESCRIPTION
----------	------------	-------------

RESISTORS

1/2 Watt

1-83	.15	56 Ω
1-3	.10	100 Ω
1-111	.10	150 Ω
1-45	.10	220 Ω
1-4	.10	330 Ω
1-6	.10	470 Ω
1-9	.10	1000 Ω
1-90	.10	2000 Ω
1-14	.10	3300 Ω
1-16	.10	4700 Ω
1-20	.10	10 K Ω
1-22	.10	22 K Ω
1-24	.10	33 K Ω
1-25	.10	47 K Ω
1-26	.10	100 K Ω
1-27	.10	150 K Ω
1-29	.10	220 K Ω
1-31	.10	330 K Ω
1-33	.10	470 K Ω
1-34	.10	680 K Ω
1-35	.10	1 megohm
1-36	.10	1.5 megohm
1-37	.10	2.2 megohm
1-38	.10	3.3 megohm
1-40	.10	10 megohm

1 Watt

1-3-1	.10	3300 Ω
1-5-1	.10	22 K Ω

7 Watt

3-15-7	.15	1000 Ω
3-16-7	.15	2500 Ω

CAPACITORS

Mica

20-130	.15	12 pf
20-77	.15	24 pf
20-96	.15	36 pf

PART No.	PRICE Each	DESCRIPTION
----------	------------	-------------

Mica (cont'd.)

20-97	.15	50 pf
20-102	.15	100 pf
20-105	.20	180 pf
20-107	.40	680 pf

Disc

21-78	.10	5 pf
21-13	.10	500 pf
21-14	.10	.001 μ fd
21-27	.10	.005 μ fd
21-16	.10	.01 μ fd
21-31	.10	.02 μ fd

Other Capacitors

25-115	.45	10 μ fd electrolytic
25-135	.75	20 μ fd tubular electrolytic
26-94	1.85	13 pf differential
26-122 (109)	2.05	2-section variable
27-34	.25	.2 μ fd resin
27-19	1.50	1 μ fd tubular
31-36	.85	8-50 pf trimmer

COILS

40-484	.15	36 μ h
40-487	.20	300 μ h
40-587	1.25	6.6 MHz trap
40-686	.50	7 MHz
40-687	.50	14/21 MHz
40-693	.80	28 MHz
40-688	.50	29 MHz
40-692	.80	29.5 MHz
40-685	.65	3.5 MHz
40-689	.95	3.5/7 MHz
40-690	.65	14/21 MHz
40-691	.95	28.5/29 MHz

TRANSFORMERS

52-65	5.90	8.4-8.9 MHz bandpass
52-73	1.35	3.395 MHz IF
52-79	.80	3.395 MHz

PART No.	PRICE Each	DESCRIPTION
----------	------------	-------------

DIODES

56-25	3.00	Zener, 15 V, 1 W (1N4166A)
56-26-1	.35	1N191 germanium
57-27	.60	Silicon 750 ma 500 PIV

CONTROLS

10-147	.75	200 Ω
10-149	.60	500 K Ω

SWITCHES

63-396	.90	Rotary wafer
63-397	.85	Rotary wafer

CRYSTALS

404-43	5.00	100 kHz
404-205	5.00	3393.6 kHz
404-215	4.50	3395.4 kHz
404-206	5.00	3396.4 kHz
404-207	4.35	12.395 MHz
404-208	4.35	15.895 MHz
404-209	4.35	22.895 MHz
404-210	4.35	29.895 MHz
404-211	4.35	36.895 MHz
404-212	4.35	37.395 MHz
404-213	4.35	37.895 MHz
404-214	4.35	38.395 MHz

CIRCUIT BOARDS

85-127-1	2.15	Modulator
85-128-2	1.55	IF
85-129-2	2.00	Bandpass
85-130-1	1.70	Audio
85-131-2	2.10	RF-driver
85-132-1	.85	Crystal
85-133-1	.85	Heterodyne oscillator
85-133-2	.85	Driver grid
85-133-3	.85	Driver plate

MISCELLANEOUS

45-51	.25	15 μ h choke
84-22	.60	P.E.C. (printed electronic circuit)
250-133	.05	3-48 x 7/16" screw
252-1	.05	3-48 nut
254-7	.05	#3 lockwasher
344-50	.05/ft	Black hookup wire

PART No.	PRICE Each	DESCRIPTION
----------	------------	-------------

Miscellaneous (cont'd.)

346-1	.05/ft	Small sleeving
434-74	.15	Crystal socket
434-129	.15	7-pin tube socket
434-130	.15	9-pin tube socket
490-5	.05	Nut starter
331-6	.10	Solder
595-840	2.00	Manual

Chassis Parts

PART No.	PRICE Each	DESCRIPTION
----------	------------	-------------

RESISTORS**1/2 Watt**

1-41	.10	10 Ω
1-83	.15	56 Ω
1-3	.10	100 Ω
1-4	.10	330 Ω
1-96	.10	750 Ω
1-9	.10	1000 Ω
1-90	.10	2000 Ω
1-16	.10	4700 Ω
1-20	.10	10 K Ω
1-22	.10	22 K Ω
1-25	.10	47 K Ω
1-35	.10	1 megohm
1-37	.10	2.2 megohm
1-38	.10	3.3 megohm

Precision (1/2 Watt)

2-76	.25	500 K Ω 1%
------	-----	-------------------

CAPACITORS**Mica**

20-130	.15	12 pf
20-77	.15	24 pf
20-102	.15	100 pf
20-105	.20	180 pf

Disc

21-14	.10	.001 μ fd
21-27	.10	.005 μ fd
21-44	.15	.005 μ fd 1.6 KV
21-16	.10	.01 μ fd
21-31	.10	.02 μ fd



<u>PART No.</u>	<u>PRICE Each</u>	<u>DESCRIPTION</u>	<u>PART No.</u>	<u>PRICE Each</u>	<u>DESCRIPTION</u>
Other Capacitors			TERMINAL STRIPS		
26-24	2.20	20 pf variable	431-62	.10	3-lug miniature
26-77	5.00	250 pf variable	431-12	.10	4-lug
26-109	1.95	2-section variable	431-11	.10	5-lug
26-92	2.85	3-section variable	431-45	.10	6-lug
23-59	.20	.05 μ fd tubular	CONNECTORS-JACKS-PLUGS		
27-34	.25	.2 μ fd resin	432-38	1.10	Male connector
COILS			432-39	1.10	Female connector
40-546	.60	8.5 MHz trap coil	436-4	.35	3-lug jack
40-549	.45	10-meter coil	436-21	.95	4-lug jack
40-548	4.00	Final tank coil	438-4	.10	Phono plug
CHOKES			438-29	.40	11-pin plug
45-41	.95	425 μ h	SOCKETS		
45-30	.40	.5 mh	434-39	.15	Octal
45-53	.40	Parasitic	434-42	.10	Phono
DIODES			434-44	.15	Pilot lamp
56-26-1	.35	1N191 germanium	434-118	.40	11-pin
57-27	.60	Silicon 750 ma 500 PIV	434-143	1.00	Relay
CONTROLS			SHIELDS		
10-57	.35	10 K Ω tab mount	206-77	.15	Small tube, 1-3/4" long
10-208	1.95	100 K Ω with switch lever	206-68	.10	Large tube, 1-3/4" long
10-68	.65	500 K Ω	206-206	.15	Large tube, 2" long
10-153	.75	1 megohm miniature	206-86	.10	Pilot lamp
10-154	.75	10 megohm miniature	TUBES-PILOT LAMP		
12-48	1.50	10 K Ω and 1 megohm dual	411-59	1.35	OA2 tube
SWITCHES			411-11	1.00	6AU6 tube
60-2	.25	DPDT slide	411-128	1.60	6BN8 tube
60-4	.20	SPDT slide	411-67	1.05	6CB6 tube
60-1	.15	SPST slide	411-63	1.90	6CL6 tube
63-395	1.10	Rotary wafer (blue dot)	411-124	1.50	6EA8 tube
63-400	1.80	3-position single wafer	411-173	1.55	6GW8 tube
63-94	1.10	5-position single wafer	411-24	1.45	12AT7 tube
63-349	2.40	4-position single wafer with snap switch	411-25	1.20	12AU7 tube
63-399	2.10	4-position double wafer	411-75	4.35	6146 tube
INSULATORS			412-14	.15	#44 pilot lamp
71-4	.45	Standoff	HARNESSES-WIRE-SLEEVING		
73-3	.10	1/2" rubber grommet	134-121	5.00	Wire harness
73-46	.10	5/16" plastic grommet	134-122	5.00	Coaxial cable harness
			340-3	.05/ft	Small bare wire

PART No.	PRICE Each	DESCRIPTION
----------	------------	-------------

Harnesses-Wire-Sleeving (cont'd.)

340-2	.05/ft	Large bare wire
346-2	.05/ft	Large sleeving
343-7	.05/ft	Coaxial cable (RG-174/U)
344-51	.05/ft	Brown hookup wire
344-59	.05/ft	White hookup wire
344-21	.05/ft	Large red hookup wire

SHAFTS-BUSHINGS-SHAFT COUPLING

453-146	1.00	8-1/4" long tubular shaft
453-17	.15	9" long shaft
453-125	.25	9-3/8" long shaft
453-147	.65	11-1/4" long shaft
455-11	.10	Split bushing
455-15	.10	1/4" shaft collar
455-10	.10	3/8" long bushing
455-18	.15	9/16" long bushing
455-44	.15	Nylon bushing
456-4	.70	Shaft coupling

KNOBS-KNOB INSERT

462-175	.15	7/16" diameter aluminum
462-191	.70	1-1/8" diameter
462-193	1.05	2-1/2" diameter
462-218	.25	Lever
455-52	.10	Knob insert

DIAL PARTS

268-7	.25	Rubber belt
446-40	.70	Dial escutcheon
466-6	.10	3/4" diameter pulley
100-19	.20	Dial pulley with 1/4" hole
100-458	.25	Dial pulley with 9/32" hole

#100-450 Packaged Dial Drive Assembly, consisting of the following:

204-553	.55	Dial mounting bracket
100-443	1.00	Dial pointer assembly
464-30-1	.25	Plastic dial window
100-447	.50	Dial pointer drive arm
250-63	.05	3-48 x 1/8" screw
266-74	.10	Nylon spiral follower
100-445	.45	Zero set drive pulley (small)
100-449	2.50	Circular dial
100-444	1.65	Dial drive pulley (large)
455-42	.90	Drive shaft bushing package

PART No.	PRICE Each	DESCRIPTION
----------	------------	-------------

METAL PARTS

90-341	20.80	Cabinet
100-554	2.00	RF cage
consisting of the following:		
		RF cage rear plate
		RF cage top plate
		RF cage
204-573	.25	Capacitor bracket
204-588-1	.25	Control bracket
200-479-1	5.00	Chassis
203-358-2	5.00	Front panel
204-560	.25	Support rail
204-677	.10	Comb bracket
206-281	.55	Final shield
206-282	.50	Switch shield
206-280	.70	Center shield
204-737	.15	Crystal filter bracket
204-738	.15	Switch bracket
205-493-1	.55	Coil cover
266-97	.10	Slide switch actuator

TOOLS

490-1	.10	Alignment
490-19	.30	Open-end wrench
490-23	.10	#4 allen wrench
490-85	.15	#8 allen wrench

HARDWARE**#3 Hardware**

250-172	.05	3-48 x 3/8" screw
250-251	.20	3-48 x 3/8" flat head screw
252-1	.05	3-48 nut
254-7	.05	#3 lockwasher
258-5	.10	#3 spring clip

#6 Hardware

250-56	.05	6-32 x 1/4" screw
250-89	.05	6-32 x 3/8" screw
250-276	.05	6-32 x 3/8" flat head screw
250-218	.05	6-32 x 3/8" phillips head screw
250-284	.05	#6 x 1/2" sheet metal screw
250-26	.05	6-32 x 5/8" screw
250-40	.05	6-32 x 1-1/2" screw
252-3	.05	6-32 nut
253-1	.05	#6 fiber flat washer



<u>PART No.</u>	<u>PRICE Each</u>	<u>DESCRIPTION</u>	<u>PART No.</u>	<u>PRICE Each</u>	<u>DESCRIPTION</u>
#6 Hardware (cont'd.)			Other Hardware (cont'd.)		
253-2	.05	#6 fiber shoulder washer	260-39	.05	Anode clip (may vary in appearance)
253-60	.05	#6 flat washer	435-1	.10	11-pin plug retaining ring
254-1	.05	#6 lockwasher	435-10	.10	Relay socket retaining ring
255-79	.10	Threaded shoulder spacer			
259-6	.05	Small #6 solder lug			
259-1	.05	Large #6 solder lug			
#8 Hardware			MISCELLANEOUS		
250-93	.05	#8 x 1/4" setscrew	51-123	2.05	Output transformer
250-260	.05	8-32 x 1/4" oval head screw	69-35	5.80	4PDT relay
250-72	.05	8-32 x 3/4" screw	74-6	.25	Masking tape
252-4	.05	8-32 nut	110-40	72.70	LMO (linear master oscillator)
252-28	.10	8-32 knurled nut	255-59	.15	Foot spacer
253-45	.05	#8 flat washer	261-9	.05	Rubber foot
254-2	.05	#8 lockwasher	266-85	.40	Rotary switch detent
259-2	.05	#8 solder lug	390-147	.10	High voltage label
1/4" Control Hardware			391-49	.30	SB-101 nameplate
252-39	.05	1/4-32 nut	404-283	37.00	2.1 kHz crystal filter
253-36	.05	1/4" dished washer	407-101	8.30	Meter
253-39	.05	1/4" flat washer	440-1	.20	11-pin socket cap
253-49	.10	1/4" nylon flat washer	352-13	.15	Silicone grease
75-18	.10	1/4" nylon shoulder washer	263-7	.05	Felt pad
253-62	.05	1/4" fiber flat washer			
259-12	.05	1/4" solder lug			
3/8" Control Hardware					
252-7	.05	3/8-32 nut			
253-10	.05	3/8" flat washer			
254-5	.05	3/8" lockwasher			
259-10	.05	3/8" solder lug			
Other Hardware					
252-15	.05	4-40 nut			
254-9	.05	#4 lockwasher			
250-156	.10	4-40 x 1/8" setscrew			
207-22	.10	Cable clamp			

The above prices apply only on purchases from the Heath Company where shipment is to a U.S.A. destination. Selling prices elsewhere in U.S.A. may be slightly higher to offset transportation and local taxes. Outside the U.S.A. parts and service are available from your local Heathkit source and will reflect additional transportation, taxes, duties and rates of exchange.