

HEATHKIT[®] MANUAL

for the

LINEAR AMPLIFIER

Model SB-201

595-2207-02



HEATH COMPANY • BENTON HARBOR, MICHIGAN



Heathkit[®] Manual

for the

LINEAR AMPLIFIER

Model SB-201

595-2207-02

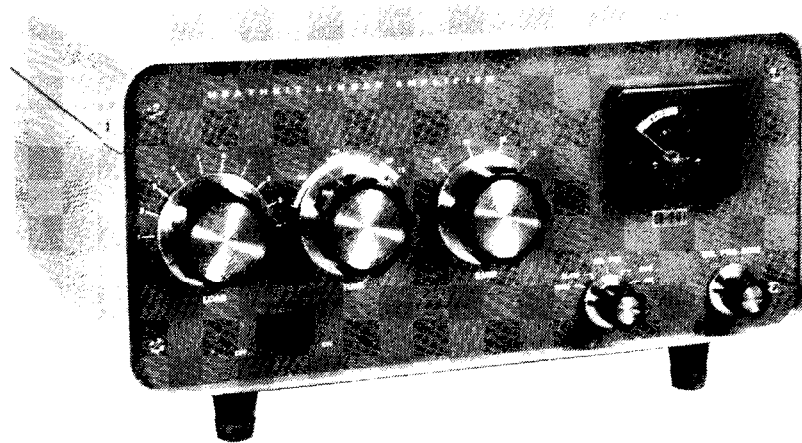

HEATH COMPANY
BENTON HARBOR, MICHIGAN 49022

Copyright © 1978
Heath Company
All Rights Reserved
Printed in the United States of America

"Federal Communications Commission requirements prescribe type acceptance of linear power amplifiers operating below 144 MHz in Part 97 of the Rules and Regulations. This Linear Amplifier will meet these requirements when constructed in strict accordance with the instructions in this manual, using only components and materials supplied with the kit or the exact equivalent thereof. You will be instructed to sign, date, place your amateur call sign, class of license, expiration date of license on the enclosed label and affix the label to the linear amplifier certifying that you have constructed this linear amplifier in accordance with the above mentioned instructions. In order to meet legal requirements, be certain to follow the instructions exactly as they are stated in this Manual.

CAUTION

Use extreme care during initial testing and all subsequent operation of this Linear Amplifier. While the SB-201 Linear Amplifier is designed for maximum safety, never lose respect for the high voltage present in this unit. Protect yourself always against lethal or severe electric shock.

HEATH COMPANY

WARNING

When you operate this Linear Amplifier, always make sure it is in its normal operating position. Never operate the Amplifier on its side. To do so may cause the filament to short to the grid, destroying the tubes and associated amplifier circuitry.



TABLE OF CONTENTS

Introduction	4	Initial Test	42
Construction Notes	4	Final Assembly	42
Parts List	5	Installation	44
Proper Soldering Techniques	8	Operation	45
Circuit Board Wiring and Soldering	10	In Case of Difficulty	48
Step-by-Step Procedure	11	Specifications	49
Step-by-Step Assembly		Circuit Description	50
Circuit Board Assembly	12	Schematic	(Illustration Booklet, Page 10)
Parts Mounting-Chassis	13	Warranty	Inside front cover
Parts Mounting-RF Shield	18	Customer Service	Inside rear cover
Wiring-RF Shield	23		
Wiring-Chassis Bottom	26		
Wiring-SWR Bridge	30		
Wiring-Chassis Top	33		
Final Wiring	37		

INTRODUCTION

The Heathkit Model SB-201 Linear Amplifier is a completely self-contained, grounded-grid, table top amplifier for use on the 80, 40, 20 and 15 meter amateur bands. The Amplifier is rated at a power input of 1200 watts peak envelope power (P.E.P.) for voice operation on SSB, and at 1000 watts on CW.

The Amplifier is designed to be used with exciters which deliver 100 watts output. It can be used with lower driving power, but its output power will be less.

A broad-band, tuned input circuit for each band feeds the two 572-B (or two T-160-L) triode tubes connected in grounded grid configuration. The tubes are cooled by a fan to prolong tube life.

An ALC circuit develops negative voltage to be fed back to the exciter to reduce its gain when the Amplifier is overdriven.

The antenna change-over relay is normally actuated by exciter relay contacts to switch the Amplifier to the transmit mode.

The Amplifier can be operated from either 120 VAC or 240 VAC 50/60 Hz lines and can be easily changed from one to the other. Operation from a 240 volt line is recommended, but not required. Each side of the line cord is equipped with a circuit breaker to protect against overloads.

CONSTRUCTION NOTES

This manual is supplied to assist you in every way to complete your kit with the least possible chance for error. The arrangement shown is the result of extensive experimentation and trial. If followed carefully, the result will be highly stable and dependable performance. We suggest that you retain the manual in your files for future reference, both in the use of the equipment and for its maintenance.

UNPACK THE KIT CAREFULLY AND CHECK EACH PART AGAINST THE PARTS LIST. In so doing, you will become acquainted with the parts. If some shortage or parts damage is found in checking the Parts List, please read the Replacements section and supply the information called for therein.

Resistors generally have a tolerance rating of 10% unless otherwise stated in the Parts List. Tolerances on capacitors are generally even greater. Limits of +100% and -20% are common for electrolytic capacitors.

We suggest that you do the following before work is started:

1. Lay out all parts so that they are readily available.

2. Provide yourself with good quality tools. Basic tool requirements consist of a screwdriver with a 1/4" blade; a small screwdriver with a 1/8" blade; phillips screwdriver; long-nose pliers; wire cutters, preferably separate diagonal cutters; a penknife or a tool for stripping insulation from wires; a soldering iron (or gun) and rosin core solder. A set of nut drivers and a nut starter, while not necessary, will aid extensively in construction of the kit.

Most kit builders find it helpful to separate the various parts into convenient categories. Muffin tins or molded egg cartons make convenient trays for small parts. Resistors and capacitors may be placed with their lead ends inserted in the edge of a piece of corrugated cardboard until they are needed. Values can be written on the cardboard next to each component. The illustration shows one method that may be used.

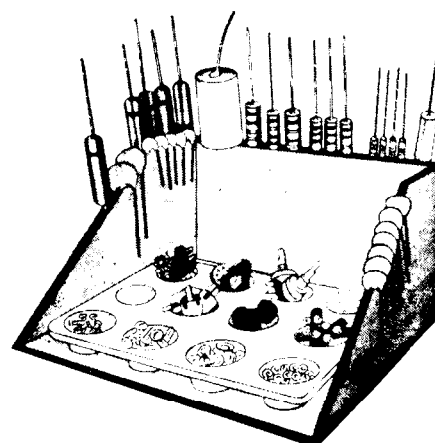



PARTS LIST

Check each part against the following list. Any part that is packed in an individual envelope should be returned to the envelope after it has been identified. Keep these parts in the envelopes until they are called for in the assembly step. Do not discard any packing materials until you account for all the parts. The key numbers correspond to the numbers on the Parts Pictorial (Illustration Booklet, Page 1).

To order a replacement part, use the Parts Order Form furnished with this kit. If a Parts Order Form is not available, refer to "Replacement Parts" inside the rear cover of the Manual. Your Warranty is located inside the front cover. For prices, refer to the separate "Heath Parts Price List."

KEY No.	HEATH Part No.	QTY.	DESCRIPTION
---------	----------------	------	-------------

RESISTORS

1/2 WATT

1	6-159	1	1.5 Ω (brown-green-gold-gold)
	6-101	2	100 Ω (brown-black-brown)
	6-472	2	4700 Ω (yellow-violet-red)
	6-153	1	15 k Ω (brown-green-orange)
	2-121	1	3600 Ω (3.6k), 1% precision

1-WATT

2	1-14-1	3	33 Ω (orange-orange-black)
	1-3-1	1	3300 Ω (orange-orange-red)
	1-38-1	3	4.7 megohm (yellow-violet-green)

OTHER RESISTORS

3	1-3-2	1	10 k Ω , 2-watt (brown-black-orange)
4	3-25-5	1	1 Ω , 1%, 5-watt
	3-12-7	1	700 Ω , 7-watt
	3-14-7	1	2000 Ω (2k), 7-watt
	5-2-7	6	30 k Ω , 7-watt
5	3-2-17	1	465 Ω , 15-watt

CAPACITORS

6	20-711	1	500 μmf 2 kV (2000V) mica
7	20-105	1	180 μmf mica
	20-108	2	200 μmf mica
	20-185	1	240 μmf mica
	20-114	1	270 μmf mica
	20-113	1	470 μmf mica
8	21-78	1	5 μmf ceramic
	21-60	1	18 μmf ceramic
	21-72	2	.005 μfd 1.4 kV ceramic

KEY No.	HEATH Part No.	QTY.	DESCRIPTION
---------	----------------	------	-------------

Capacitors (cont'd.)

	21-90	1	.001 μfd kV ceramic
	21-31	13	.02 μfd ceramic
9	21-109	1	100 μmf 5 kV tubular ceramic
	21-165	1	1000 μmf 6 kV tubular ceramic
10	25-39	1	2 μfd 150 V electrolytic
	25-19	1	20 μfd 150 V electrolytic
11	25-34	6	125 μfd 450 V electrolytic
	26-96	1	150 μmf , 3 kV, variable
	26-160	1	850 μmf variable

CONTROLS — SWITCHES

12	10-12	1	100 k Ω control
13	61-14	1	DPST rocker switch
	63-1340	1	3-wafer rotary switch
	63-352	1	1-wafer rotary switch
14	65-15	2	8-ampere circuit breaker
	69-5	1	DPDT 110 V AC relay

COILS— CHOKES — TRANSFORMERS

15	40-98	1	RF driver element
16	40-99	2	RF pickup element
17	40-591	1	80 meter input coil
	40-1980	1	40 meter input coil
	40-593	1	20 meter input coil
	40-727	1	15 meter input coil
18	40-1962	1	15 meter final coil
19	40-1666	1	20, 40, and 80 meter final coil
20	45-4	1	1.1 mh RF choke
21	45-60	1	10 μh RF choke
22	45-18	1	28 μh RF choke
23	45-61	1	50 μh RF choke
24	45-53	2	Parasitic RF choke
	54-151	1	Power transformer



KEY No.	HEATH Part No.	QTY.	DESCRIPTION
---------	----------------	------	-------------

DIODES—TUBES

25	56-26	2	1N191 crystal diode (brown-white-brown)
26	56-24	1	1N458 silicon diode, blue with a black band or (yellow-green-gray)
27	57-27	17	Silicon diode
	411-198	2	572-B tube or T160-L*

INSULATORS—GROMMETS—TERMINAL STRIPS—SOCKETS

28	71-5	1	Ceramic standoff insulator with 6-32 stud
	73-4	2	5/16" grommet
	73-1	4	3/8" grommet
	73-3	1	1/2" grommet
29	75-29	1	Line cord strain relief
30	431-50	1	1-lug terminal strip
31	431-16	1	2-lug terminal strip
	431-10	1	3-lug terminal strip
32	431-11	1	5-lug terminal strip
33	431-77	1	5-lug terminal strip
	431-45	1	6-lug terminal strip
	431-35	1	7-lug terminal strip
	431-13	1	Screw type terminal strip
34	434-9	2	4-lug tube socket
35	434-42	2	Phono socket
36	436-5	2	Coaxial socket
37	438-9	2	Coaxial plug
38	438-12	2	Coaxial plug insert
39	438-4	2	Phono plug

WIRE—CABLE—SLEEVING

89-22	1	Line cord
134-1056	1	Cable assembly
340-1	6'	Bare wire
344-52	1'	Red solid hookup wire
344-54	2'	Yellow solid hookup wire
344-55	2'	Green solid hookup wire
344-58	4'	Gray solid hookup wire
344-13	1'	Large blue hookup wire
343-2	6'	Large shielded cable (RG-58 A/U)
343-3	8'	Small shielded cable
346-4	1'	Small sleeving
346-3	2"	Large sleeving

KEY No.	HEATH Part No.	QTY.	DESCRIPTION
---------	----------------	------	-------------

HARDWARE**Screws**

40	250-213	10	4-40 × 5/16"
41	250-8	23	#6 × 3/8" sheet metal
42	250-138	2	6-32 × 3/16"
43	250-56	35	6-32 × 1/4"
44	250-89	19	6-32 × 3/8"
45	250-218	4	6-32 × 3/8" phillips head
46	250-32	9	6-32 × 3/8" flat head
47	250-26	1	6-32 × 5/8"
48	250-29	4	6-32 × 3/4"
49	250-40	2	6-32 × 1-1/2"
50	250-260	2	8-32 × 1/4"
51	250-43	9	8-32 × 1/4" setscrew
52	250-1237	1	6-32 stud
53	250-126	6	10-32 × 1/2"
54	250-331	1	10-32 × 1"
55	251-1	2	6-32 spade bolt

Nuts

56	252-15	10	4-40
57	252-3	59	6-32
58	252-5	6	10-32
59	252-163	1	10-32 wingnut
60	252-7	3	Control

Washers

61	253-27	2	5/16" steel flat
62	253-8	4	7/16" brass flat
63	253-60	8	3/8" steel flat
64	253-1	2	3/8" fiber flat
65	253-3	4	1/2" fiber flat
66	253-7	2	1/2" fiber shoulder
67	253-10	3	Flat control
68	253-19	4	3/4" steel flat
69	254-9	10	#4 lockwasher
70	254-1	64	#6 lockwasher
71	254-3	5	#10 lockwasher
72	254-4	3	Control lockwasher

*Be sure to save the tube manufacturer's warranty packed with the tube. This warranty information must be included with the tube if it is returned for warranty replacement.



KEY	HEATH	QTY.	DESCRIPTION
No.	Part No.		

OTHER HARDWARE

73	259-1	18	#6 solder lug
74	259-5	2	#10 solder lug
75	259-10	1	Control solder lug
76	260-34	2	Anode clip
77	435-1	2	Socket ring

SPACERS

78	255-42	4	3/4" phenolic spacer
79	255-12	3	Plastic spacer
80	255-59	2	Tapered spacer

METAL PARTS

81	40-100	1	Coaxial cavity
	90-341	1	Cabinet
	200-1343-1	1	Chassis
	203-1973-1	1	Front panel
82	205-492	1	Capacitor mounting bracket
83	204-560	2	Angle bracket
84	204-611	1	Circuit breaker mounting bracket
	100-1742	1	RF shield (with filter assembly)

KEY	HEATH	QTY.	DESCRIPTION
No.	Part No.		

Metal Parts (cont'd.)

85	206-255	1	Power supply shield
	205-438	1	Top plate

MISCELLANEOUS

	85-88-2	1	Circuit board
86	258-6	1	Clip
87	261-9	4	Rubber foot
88	266-900	1	Fan blade
	390-147	2	DANGER label
	390-1499	1	FCC label
	391-34	1	Blue and white label
	391-616	1	Nameplate
	407-103	1	Meter
	420-3	1	Motor
	462-191	2	Small knob
	462-210	3	Large knob
	490-5	1	Nut starter
	597-260	1	Parts Order Form
		1	Manual (See front cover for part number.)
			Solder

PROPER SOLDERING TECHNIQUES

Only a small percentage of customers find it necessary to return equipment for factory service. By far the largest portion of malfunctions in this equipment are due to poor or improper soldering.

If terminals are bright and clean and free of wax, frayed insulation and other foreign substances, no difficulty will be experienced in soldering. Correctly soldered connections are essential if the performance engineered into a kit is to be fully realized. If you are a beginner with no experience in soldering, a half hour's practice with some odd lengths of wire may be a worthwhile investment.

For most wiring, a 25 to 100 watt iron is very satisfactory. A lower wattage iron than this may not heat the connection enough to flow the solder smoothly. Keep the iron tip clean by wiping it from time to time with a cloth.

CHASSIS WIRING AND SOLDERING

1. Unless otherwise indicated, all wire used is the type with colored insulation (hookup wire). In preparing a length of hookup wire, 1/4" of insulation should be removed from each end unless directed otherwise in the assembly step.
2. To avoid breaking internal connections when stripping insulation from the leads of transformers or similar components, care should be taken not to pull directly on the lead. Instead, hold the lead with pliers while it is being stripped.
3. Leads on resistors, capacitors, and similar components are generally much longer than need be to make the required connections. In these cases, the leads should be cut to proper length before the part is installed. In general, the leads should be just long enough to reach their terminating points.
4. Wherever there is a possibility of bare leads shorting to other parts or to the chassis, the leads should be covered with insulating sleeving. Where the use of sleeving is specifically intended, the phrase "use sleeving" is included in the associated assembly step. In any case where there is the possibility of an unintentional short circuit, sleeving should be used. Extra sleeving is provided for this purpose.
5. Crimp or bend the lead (or leads) around the terminal to form a good joint without relying on solder for physical strength. If the lead is too large to allow bending or if the step states that it is not to be crimped, position it so that a good solder connection can still be made.

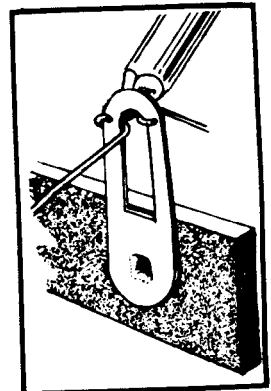
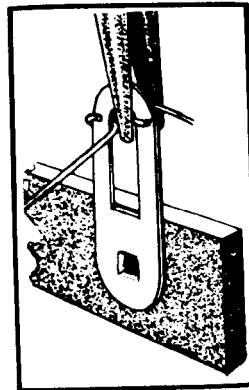

6. Position the work, if possible, so that gravity will help to keep the solder where you want it.
7. Place a flat side of the soldering iron tip against the joint to be soldered until it is heated sufficiently to melt the solder.



8. Then place the solder against the connection and it will immediately flow over the joint; use only enough solder to thoroughly wet the junction. It is usually not necessary to fill the entire terminal with solder.
9. Remove the solder and then the iron from the completed joint. Use care not to move the leads until the solder is solidified.

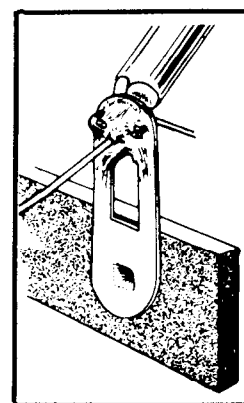
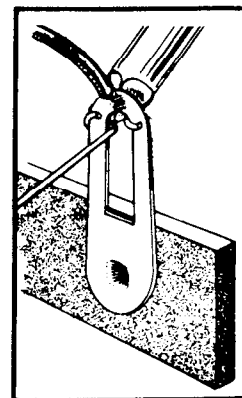

A poor or cold solder joint will usually look crystalline and have a grainy texture, or the solder will stand up in a blob and will not have adhered to the joint. Such joints should be reheated until the solder flows smoothly. In some cases, it may be necessary to add a little more solder to achieve a smooth, bright appearance.

ROSIN CORE SOLDER HAS BEEN SUPPLIED WITH THIS KIT. THIS TYPE OF SOLDER MUST BE USED FOR ALL SOLDERING IN THIS KIT. ALL GUARANTEES ARE VOIDED AND WE WILL NOT REPAIR OR SERVICE EQUIPMENT IN WHICH ACID CORE SOLDER OR PASTE FLUXES HAVE BEEN USED. IF ADDITIONAL SOLDER IS NEEDED, BE SURE TO PURCHASE ROSIN CORE (60:40 or 50:50 TIN-LEAD CONTENT) RADIO TYPE SOLDER.

CIRCUIT BOARD WIRING AND SOLDERING

Before attempting any work on the circuit board, read the following instructions carefully and study the Figures. It is only necessary to observe the following basic precautions to insure proper operation of the unit the first time it is turned on.

Proper mounting of components on the board is essential for good performance. A good general rule to follow is that all components on the board should be mounted tightly to the board, unless instructions state otherwise. All leads should be kept as short as possible to minimize the effects of stray capacity in the wiring. Proper and improper methods of mounting are illustrated in the accompanying Figures.

NOTE: Exercise care not to damage resistors or capacitors when bending the leads as shown.

Tubular capacitors and resistors will fit properly if the leads are bent as shown. Components with lugs normally require no preparation unless the lugs appear to be bent, in which case they can be straightened with pliers.

Parts should be inserted as instructed, and the leads bent outward, as illustrated, to lock them in place. When a group of parts have been installed on a circuit board, solder each lead to the foil pattern and clip off the excess wire.

The actual technique of soldering leads to a circuit board is quite simple. Position the tip of the soldering

iron so that it firmly contacts both the circuit board foil and the wire or lug to be soldered, as shown. The iron should be held so that solder is not likely to flow to adjacent foil conductors or connections. The solder should immediately be placed between the iron and the joint to be soldered. Remove the length of solder as soon as its end begins to melt and flow onto the lead and foil. Hold the tip of the iron in place only until the solder begins to flow outward over the foil; then remove the iron quickly.

Avoid overheating the connection. A soldering pencil or small iron (approximately 25 watts) is ideal for use in circuit board work. If only a high wattage iron or soldering gun is available, precautions must be taken to avoid circuit board damage due to overheating and excess solder.

The use of excessive amount of solder will increase the possibility of bridging between foil conductors or plugging holes which are to be left open for wires which may be added later on. If solder is accidentally bridged across insulating areas between conductors, it can be cleaned off by heating the connection carefully and quickly wiping or brushing the solder away with a soft cloth or clean brush. Holes which become plugged can be cleared by heating the area immediately over the hole while gently pushing the lead of a resistor through the hole from the opposite side, and withdrawing the lead before the solder rehardens. Do not force the lead through; too much pressure before the solder has time to soften may separate the foil from the board.

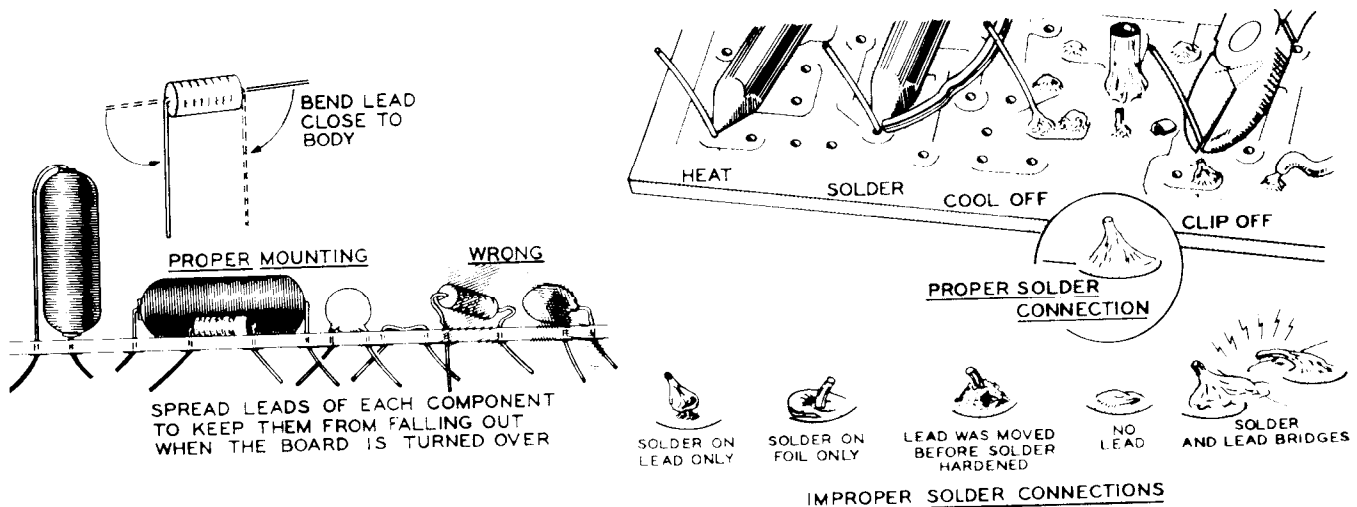



STEP-BY-STEP PROCEDURE

The following instructions are presented in a logical step-by-step sequence to enable you to complete your kit with the least possible confusion. Be sure to read each step all the way through before beginning the specified operation. Also read several steps ahead of the actual step being performed. This will familiarize you with the relationship of the subsequent operations. When the step is completed, check it off in the space provided. This is particularly important as it may prevent errors or omissions, especially if your work is interrupted. Some kit builders have also found it helpful to mark each wire and part in colored pencil on the Pictorial as it is added.

ILLUSTRATIONS

A separate Illustration Booklet, contains illustrations (Pictorials, Details, etc.) that are too large for the Assembly Manual. The illustrations are arranged in number sequence. When an illustration is referred to, and is not on either of the open pages of the Assembly Manual, the illustration will be found in the Illustration

Booklet. Place the Illustration Booklet in a convenient location and keep it with the Assembly Manual.

SOLDERING

The abbreviation "NS" indicates that a connection should not be soldered yet as other wires will be added. When the last wire is installed, the terminal should be soldered and the abbreviation "S" is used to indicate this. Note that a number will appear after each solder instruction. This number indicates the number of leads that are supposed to be connected to the terminal in point before it is soldered. For example, if the instruction reads, "Connect a wire to lug 1 (S-2)," it will be understood that there will be two wires connected to the terminal at the time it is soldered. (In cases where a wire passes through a terminal or lug and then connects to another point, it will count as two wires, one entering and one leaving the terminal.)

STEP-BY-STEP ASSEMBLY

CIRCUIT BOARD ASSEMBLY

- (1) Locate the circuit board and position it as shown in Pictorial 1; then complete the steps around this Pictorial. Be sure to read Page 10 of the manual before beginning assembly of the kit.

- (2) Install sixteen silicon diodes. Position the banded end of each diode as shown. Solder and cut off the excess leads except the indicated lead of the first diode.

IMPORTANT: THE BANDED END OF DIODES CAN BE MARKED IN A NUMBER OF WAYS.

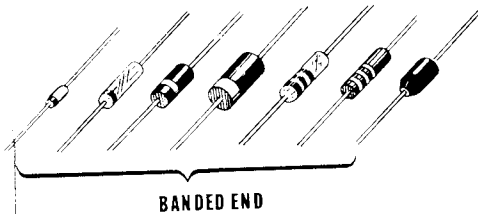

CUT THIS LEAD TO APPROXIMATELY 1/2" LONG.

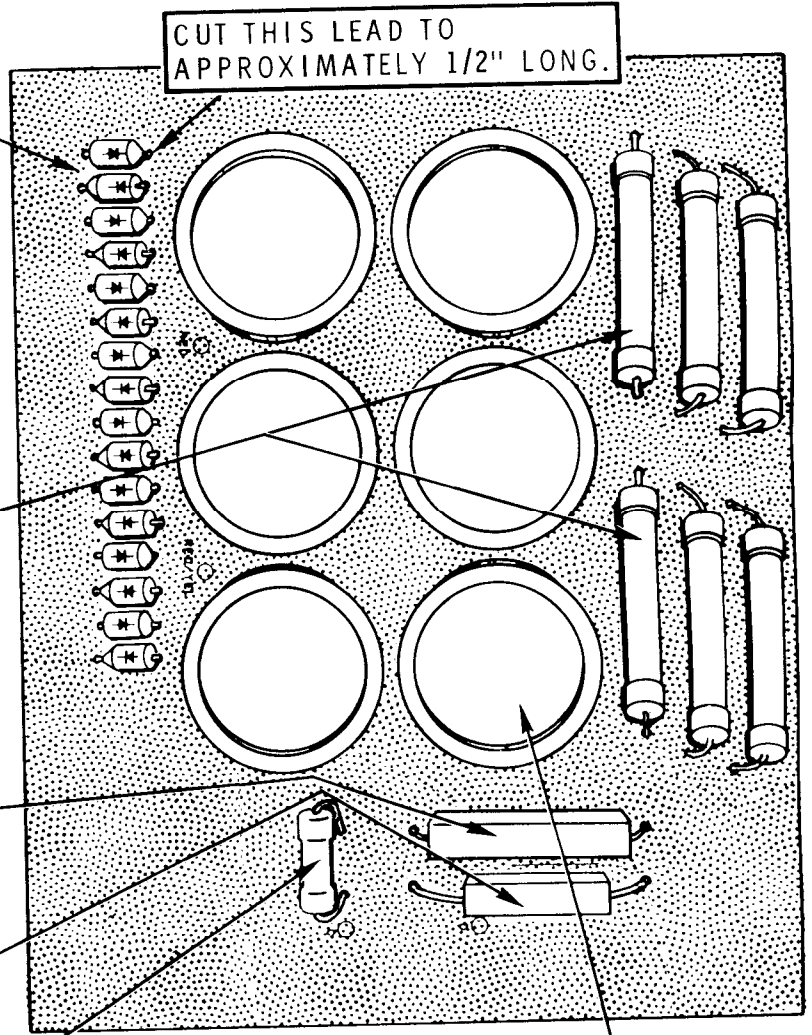

- (3) Install the six 30 kΩ (30,000 Ω) 7 watt resistors. Use the 500 μf mica capacitor as a temporary spacer between each resistor and the circuit board. Solder and cut off the excess leads as each resistor is installed. Space these resistors so they do not touch the electrolytic capacitors, the circuit board or each other.

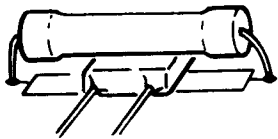

- (4) Install the 700Ω 7 watt resistor, using the 500 μf mica capacitor as a temporary spacer between the resistors and circuit board. Solder and cut off the excess leads.

- (5) In a like manner, install the 1 Ω 5 watt precision resistor, using the same capacitor as a spacer. Solder and cut off the excess leads.

- (6) Install the 3600 Ω 1/2 watt precision resistor. Solder and cut off the excess leads.

- (7) Install the six 125 μfd electrolytic capacitors. Position the center lug in the large center hole and the four other lugs in outside holes in the circuit board for each capacitor. Bend the center lugs over against the foil and twist the outside lugs 1/8 turn. Solder all lugs which extend through foil.

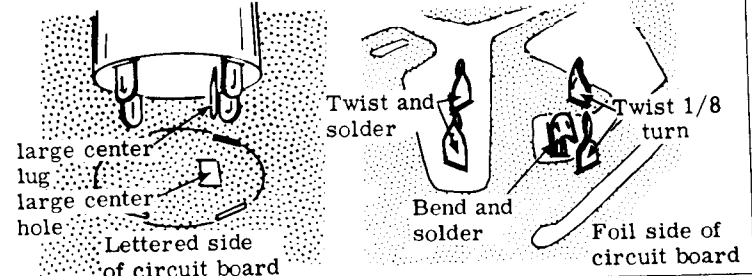

PICTORIAL 1

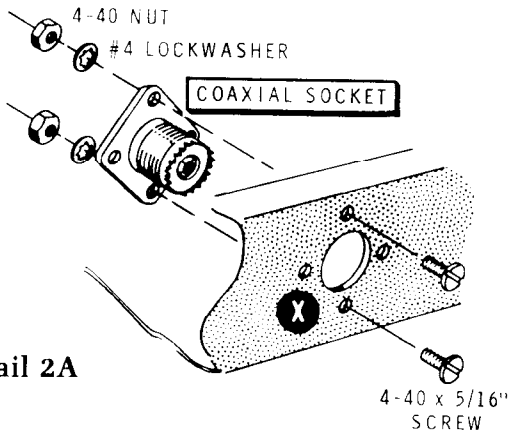

Detail 2A

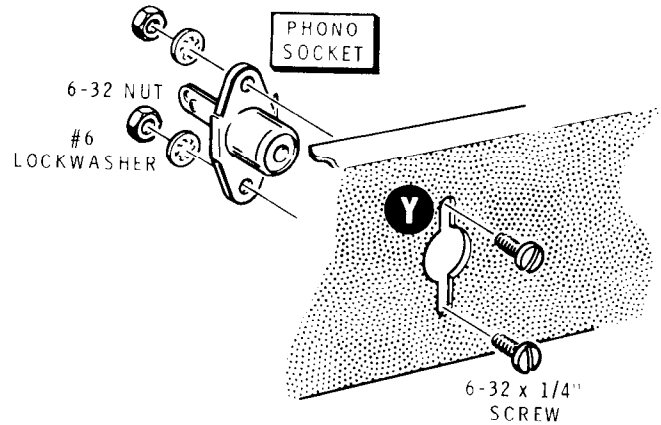

Detail 2C

PARTS MOUNTING — CHASSIS

Refer to Pictorial 2 (Illustration Booklet, Page 2) for the following steps.

NOTES:

1. Lockwashers and nuts will be used with all screws in mounting parts, unless stated otherwise in the assembly steps. Consequently, the following steps will call out only the size and type of hardware to be used. For example, the phrase "6-32 x 1/4" hardware" means to use 6-32 x 1/4" screws, #6 lockwashers and 6-32 nuts.
 2. Use the plastic nut starter provided with this kit to hold and start 4-40 and 6-32 nuts on screws.
- (✓) Refer to Detail 2A and install a coaxial socket at X. Use 4-40 x 5/16" hardware in the two holes shown. The remaining hardware for this socket will be installed later.

- (✓) Refer to Detail 2B and install a coaxial socket on the rear chassis apron at T. Use 4-40 x 5/16" hardware.
- (✓) Refer to Detail 2B and locate the ceramic insulator with the 6-32 stud. Cut off the tip as shown.
- (✓) Mount the ceramic insulator at U. Use a #6 lockwasher and a 6-32 nut.
- (✓) Refer to Detail 2C and install a phono socket at Y. Use 6-32 x 1/4" hardware. Position the socket as shown in the Pictorial.
- (✓) Similarly mount a phono socket at Z using 6-32 x 1/4" hardware.
- (✓) Refer to Detail 2D and install the 10-32 x 1" screw at W. Use #10 lockwashers, a 10-32 nut, 3/4" steel flat washers, and a 10-32 wingnut.

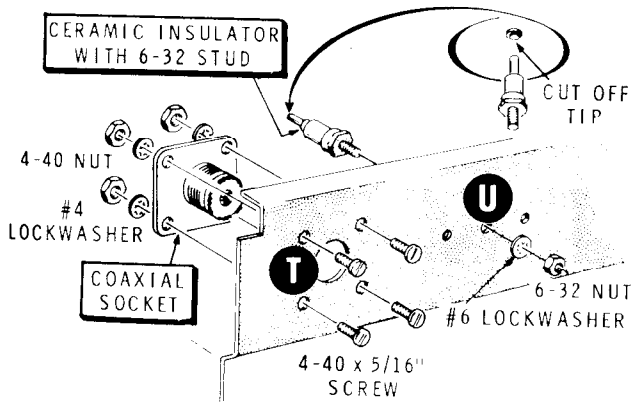

Detail 2B

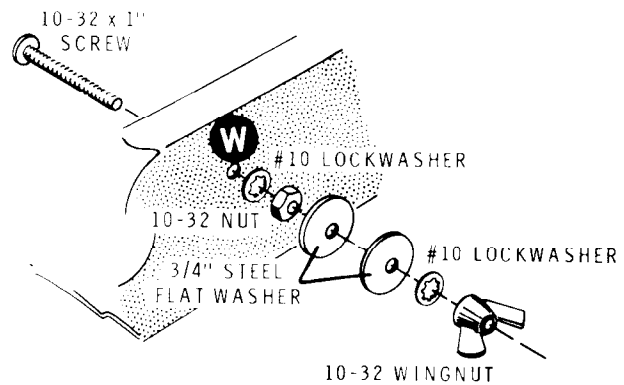

Detail 2D

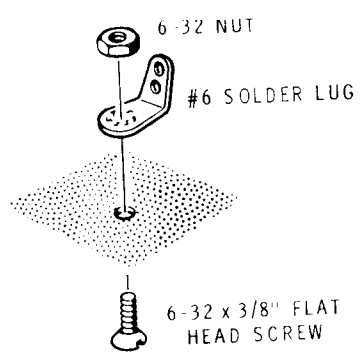

Detail 2E

- (✓) Refer to Detail 2E and install a #6 solder lug at BB. Use a 6-32 x 3/8" flat head screw and a 6-32 nut. Position the solder lug as shown on the Pictorial.
- (✓) Refer to Detail 2F and secure two 3/4" phenolic spacers at S. Use #6 solder lugs, 7/16" brass flat washers, and 6-32 x 3/8" flat head screws. Do not overtighten the screws as the spacer threads could be stripped.

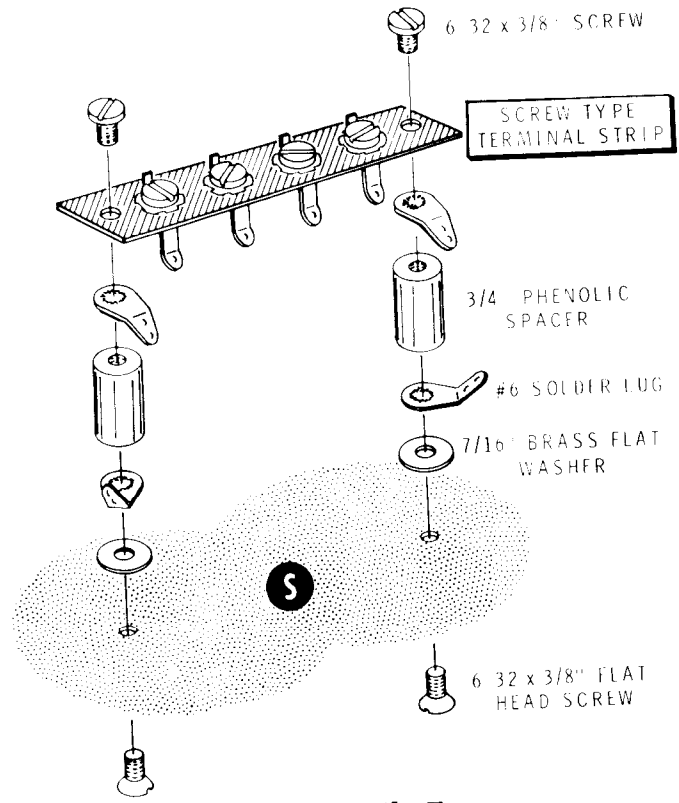

Detail 2F

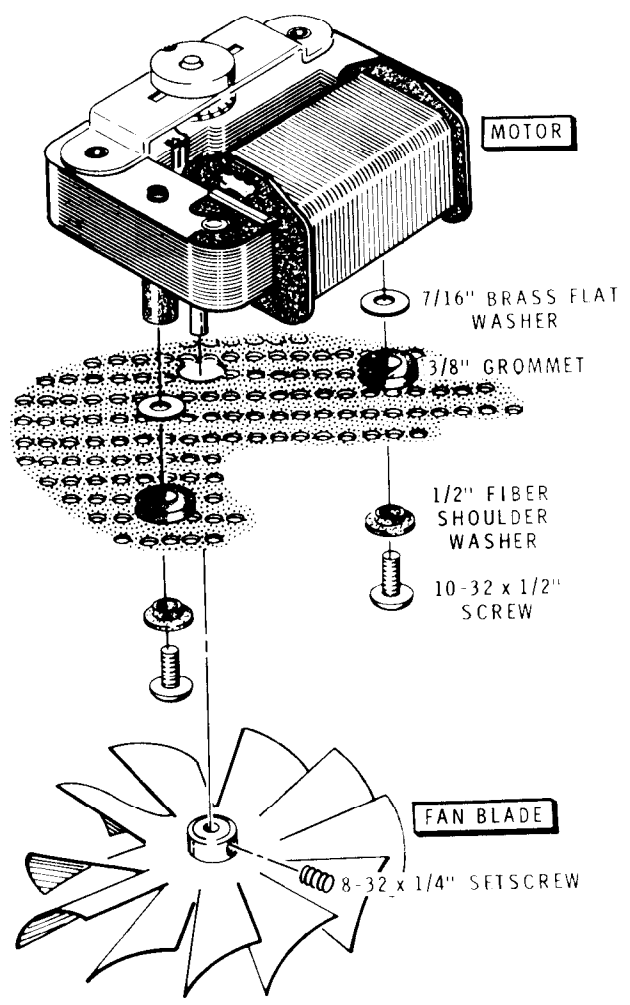

Detail 2G

- (✓) Secure the screw type terminal strip to the other end of the phenolic spacers, using #6 solder lugs and 6-32 x 3/8" screws.
- (✓) Refer to Detail 2-G and install the motor to the chassis. Use 3/8" grommets, 7/16" brass flat washers, 1/2" screws. Position the motor as shown in the Pictorial.
- (✓) Locate the fan blade and start an 8-32 x 1/4" setscrew into the fan bushing.
- (✓) Place the fan blade over the motor shaft so the shaft is flush with the edge of the fan blade bushing. Then tighten the setscrew.

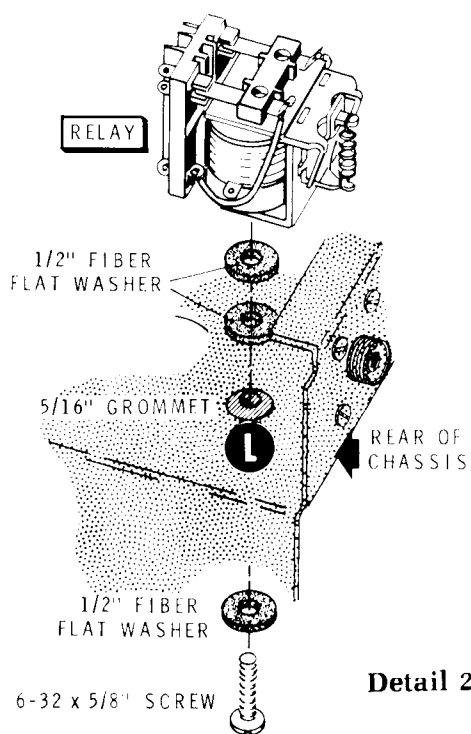

Detail 2H

(✓) Refer to Detail 2H and install the relay (#69-5) at L. Use a 5/16" rubber grommet, three 1/2" fiber flat washers, and a 6-32 × 5/8" screw.

(✓) Refer to Detail 2J and install a 100 kΩ control (#10-12) at C. Use a control lockwasher and a control nut. Position the control lugs as shown.

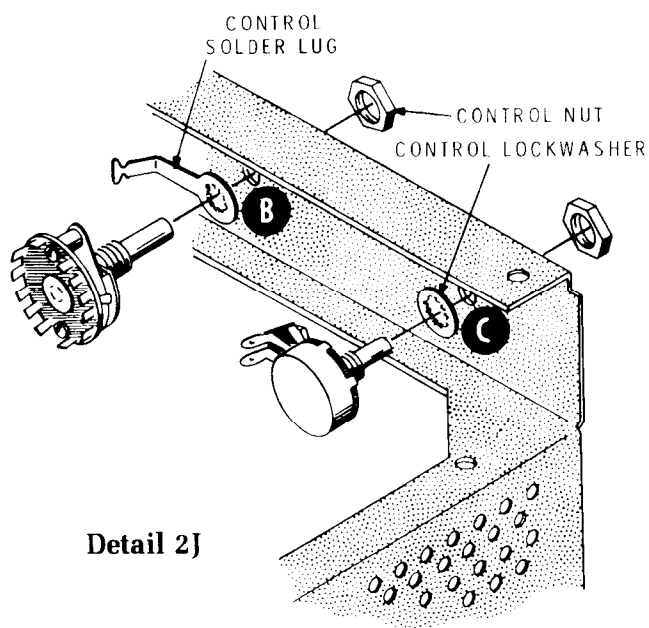

Detail 2J

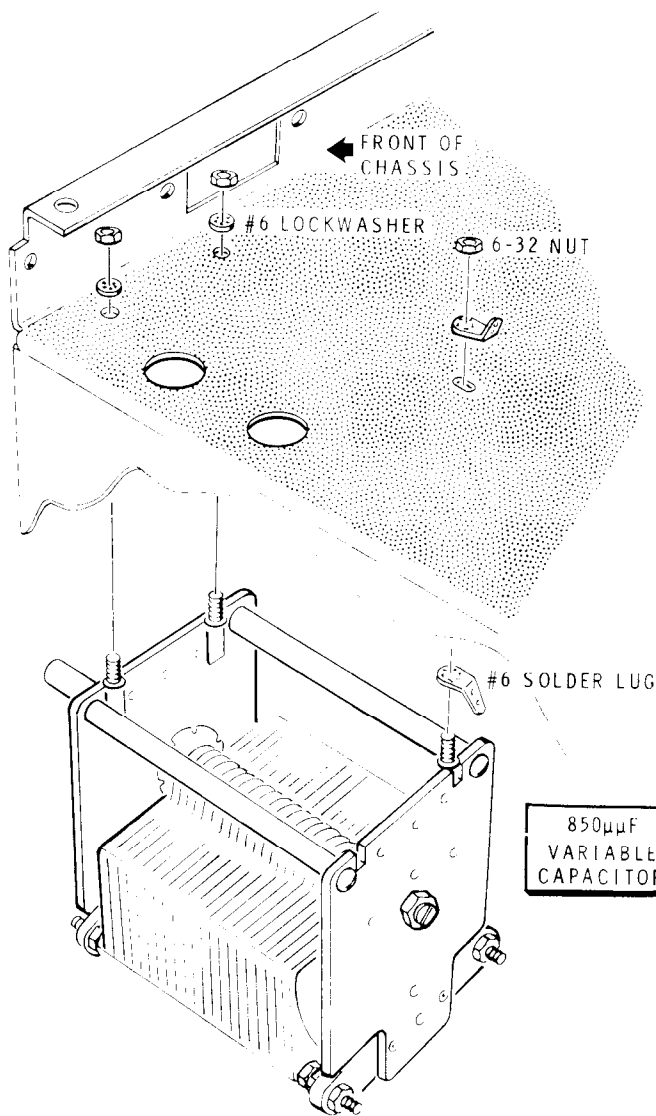

Detail 2K

(✓) Similarly, install the 1-wafer rotary switch (#63-352) at B. Use a control solder lug and a control nut. Position the switch lugs and solder lug as shown in the inset drawing in Pictorial 2.

NOTE: Be sure to keep the plates of the variable capacitors fully meshed (closed) at all times to prevent damage during handling.

(✓) Refer to Detail 2K and install the 850 μμf variable capacitor (#26-160) on the top of the chassis at D. Use #6 lockwashers, 6-32 nuts and two #6 solder lugs at the locations shown.

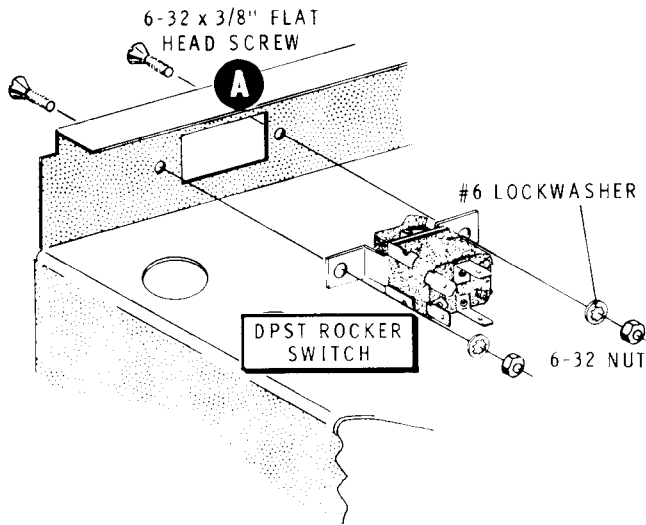

Detail 2L

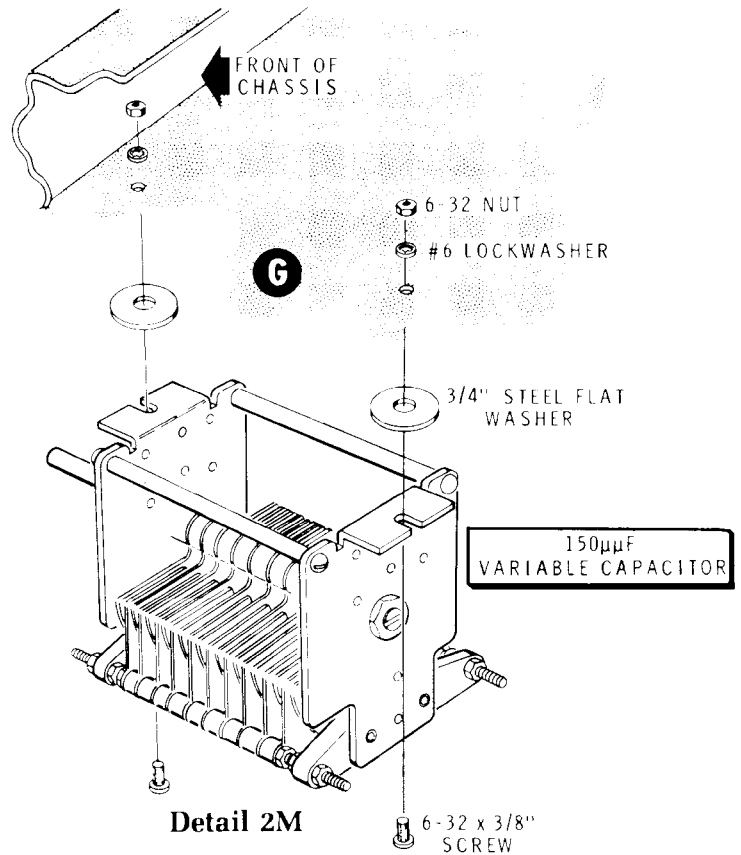

Detail 2M

- () Refer to Detail 2L and install the DPST rocker switch at A. Use 6-32 × 3/8" flat head hardware. Be sure to position the switch lugs as shown. Operate the rocker switch to see that it functions properly.
- () Install a 5/16" rubber grommet at F.
- () Install a 1/2" rubber grommet at P.
- () Install a 3/8" rubber grommet at I.
- () Install a 3/8" rubber grommet at BA.
- () Install the 150 μμf variable capacitor (#26-96) on top of the chassis at G. Use 6-32 × 3/8" hardware with two 3/4" steel flat washers as shown in Detail 2M. Position the capacitor as shown.

Refer to Detail 2N for the following steps.

- () Locate the power transformer and cut the leads to the following lengths. Measure the leads from where they come out of the transformer.

<u>LEAD COLOR</u>	<u>LENGTH</u>
Both green	9-1/2"
Either blue	7-1/2"
Red-yellow	7"
Black-red	6"
Black	6-1/2"
Red	5-1/2"
Other blue	3"
Black-green	3"
Black-yellow	3"
Green-yellow	3"

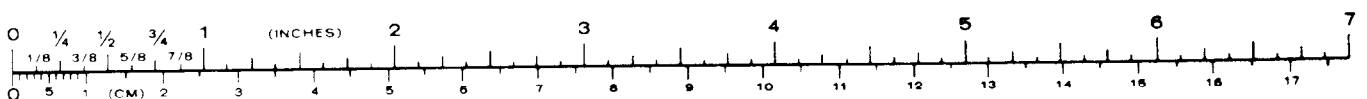

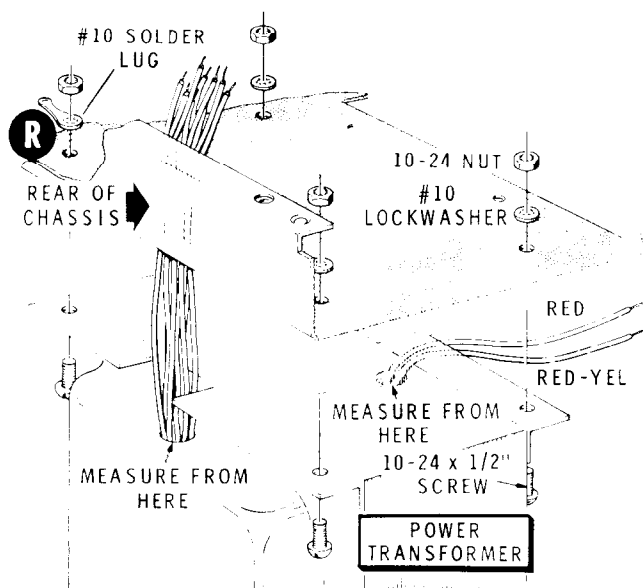

Detail 2N

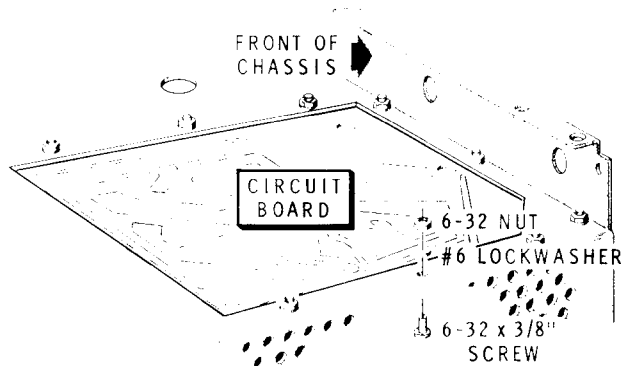

Detail 2P

- (✓) Strip 1/4" insulation from the end of each transformer lead. Twist the fine strands together and melt a small amount of solder on the exposed lead end to hold the small wire strands together.
- (✓) Position the power transformer as shown. Place the chassis over the top of the transformer with the red and the red-yellow leads toward the front of the chassis and the remaining leads through the large hole in the chassis as shown.
- (✓) Secure the power transformer to the chassis, using 10-24 x 1/2" hardware with a #10 solder lug at R.
- (✓) Refer to Detail 2P and install the circuit board on the top of the chassis. Use 6-32 x 3/8" hardware. Be sure to position the circuit board as shown.
- (✓) Refer to Detail 2R and install a 1-lug terminal strip at V. Use 6-32 x 1/4" hardware. Position the terminal strip as shown.

Temporarily set the chassis aside.

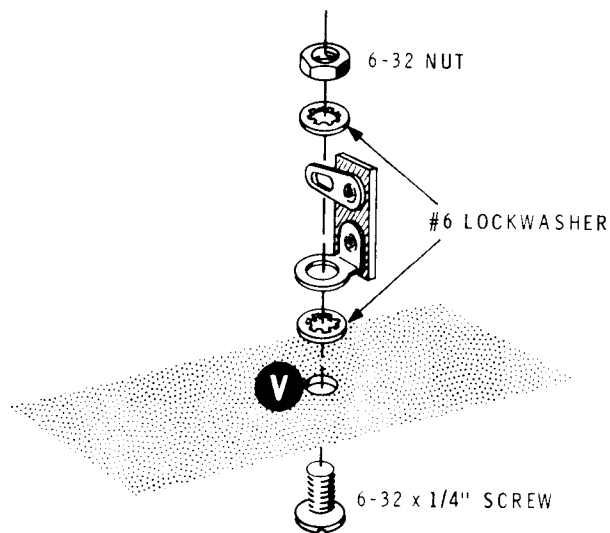

Detail 2R

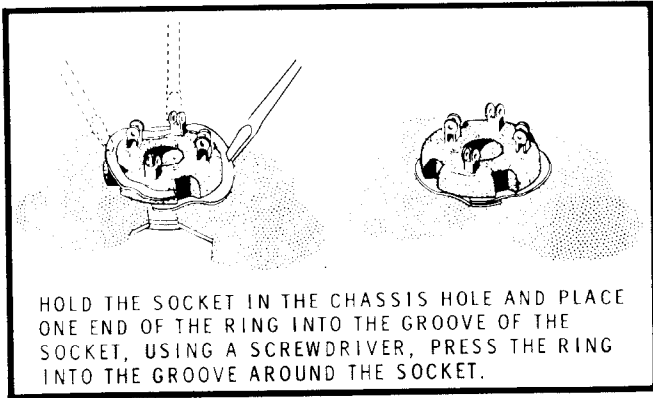

Detail 3A

PARTS MOUNTING—RF SHIELD

Refer to Pictorial 3 (Illustration Booklet, Page 3) for the following steps.

- (✓) Locate the RF shield and position it as shown.
- (✓) Install #6 $\times 3/8$ " sheet metal screws at BA and BB from the inside of the RF shield.
- (✓) Refer to Detail 3A and use socket rings to install 4-lug tube sockets at V1 and V2. Place each socket so lug 1 is positioned as shown in the Pictorial.
- (✓) Refer to Detail 3B and install a 7-lug terminal strip at AA on the RF shield with two #6 solder lugs at AB and one #6 solder lug at AC. Use 6-32 $\times 1/4$ " hardware. Position the solder lugs as shown in the Pictorial.
- (✓) Refer to Detail 3C and install a 5-lug terminal strip (#431-77) at M. Use 6-32 $\times 1/4$ " hardware.
- (✓) Refer to Detail 3D and install two #6 solder lugs at AD. Use 6-32 $\times 1/4$ " hardware. Position the solder lugs as shown in the Pictorial.
- (✓) Locate the 3-wafer rotary switch (#63-1340) and slide the rear wafer off the switch shaft.
- (✓) Place a control lockwasher on the knob end of the shaft.

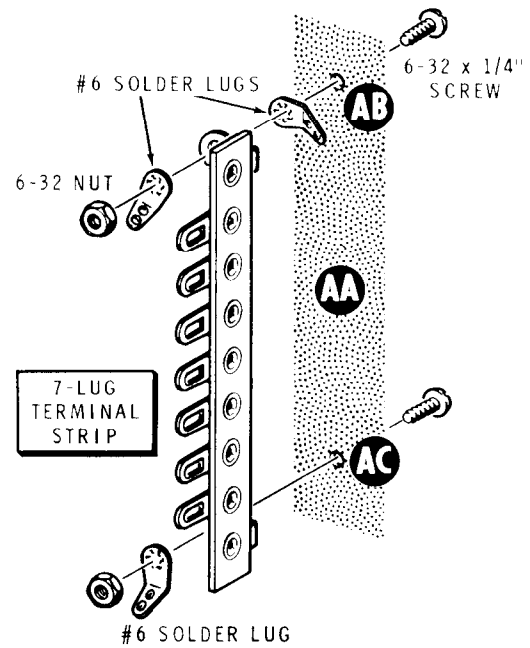

Detail 3B

- (✓) Refer to Detail 3E and position the switch as shown in the RF shield. Place the shaft through the hole in the rear of the bracket and then position the knob end of the switch through hole AK as shown.
- (✓) Temporarily secure the switch to the RF shield with a control nut. Do not tighten the control nut at this time.
- (✓) Turn the shaft of the switch fully counter-clockwise.

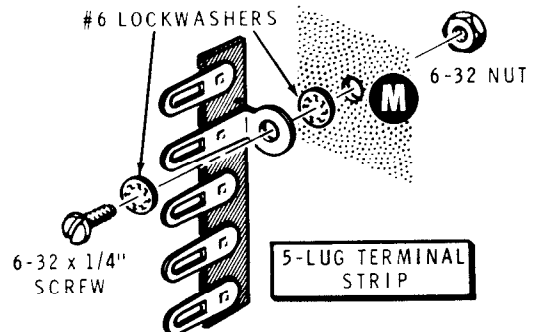

Detail 3C

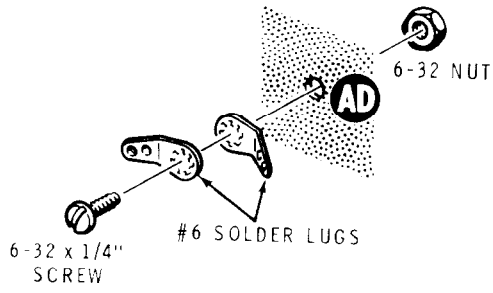

Detail 3D

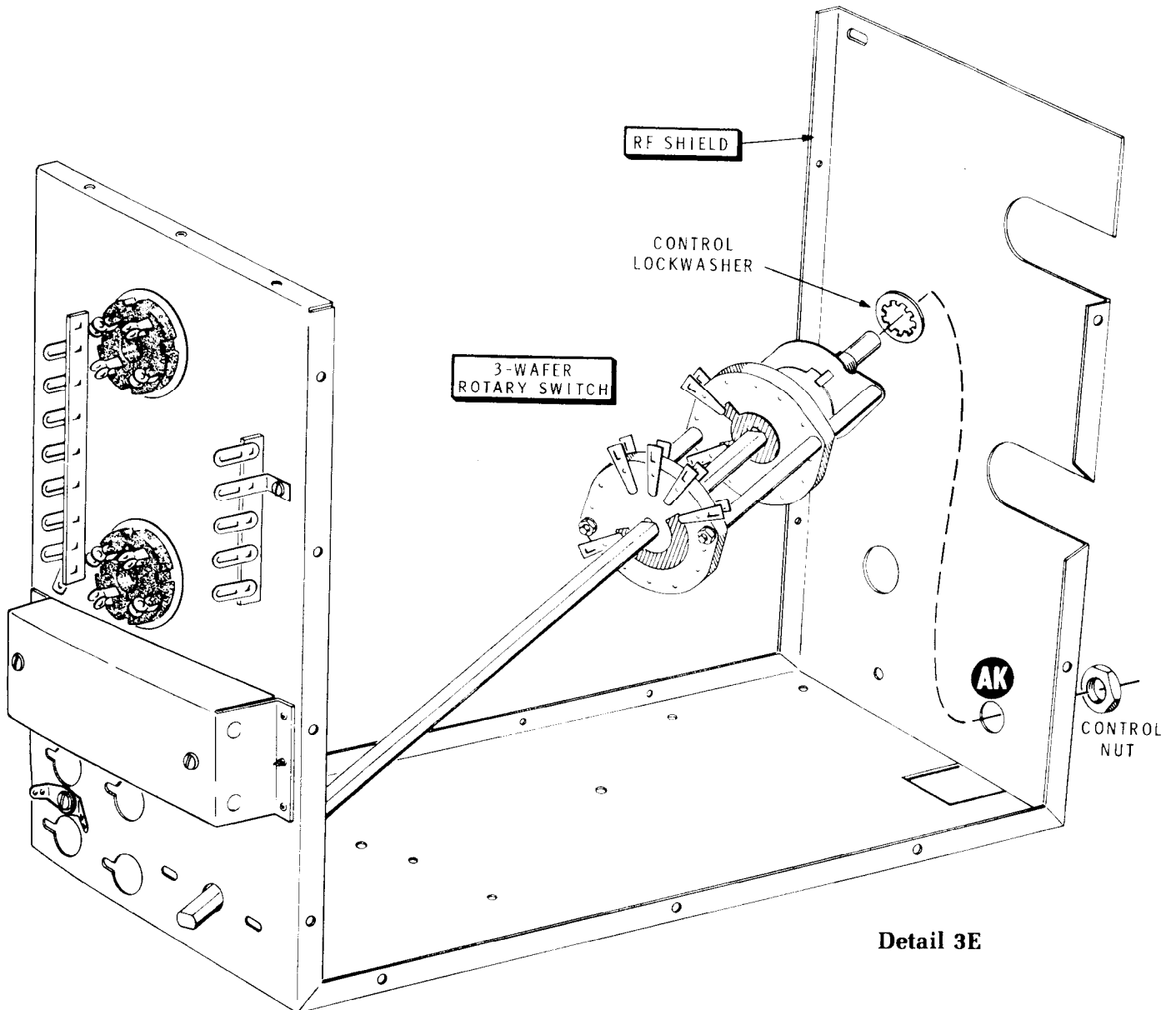

Detail 3E

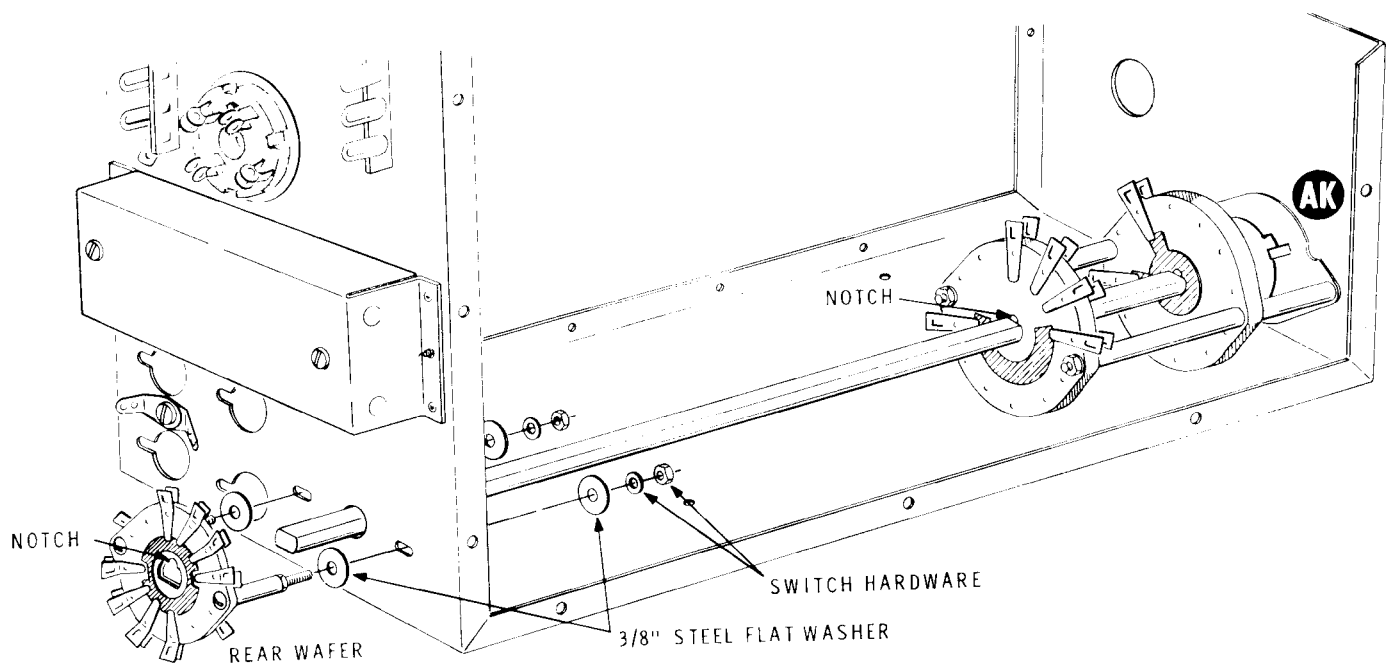

Detail 3F

- (✓) Refer to Detail 3F and install the rear wafer of the switch on the bracket by removing one nut and one lockwasher from each mounting screw. This should leave one lockwasher and nut on each mounting screw. Position the movable wiper of this wafer as shown and place a 3/8" flat steel washer on each mounting screw.
- () Secure the rear wafer of the switch to the RF shield. Use two 3/8" steel flat washers, the clip, and the switch hardware at AE. Position the clip against the switch shaft as shown in the inset drawing on Pictorial 3. Use two 3/8" steel flat washers and the switch hardware at AF. Be sure the notch of the rear wafer rotor is aligned with the notch of the rotors of the other two wafers.
- (✓) Now tighten the control nut securing the switch at AK.
- (✓) Refer to Detail 3G and mount a #6 solder lug at AJ on the RF shield with a 6-32 × 1/4" screw and a 6-32 nut. Position the solder lug as shown.

Refer to Detail 3H for the following steps.

NOTE: Do not overtighten the phenolic spacers in the following steps, as the threads could strip out easily.

- (✓) Install 3/4" phenolic spacers to the indicated side of the 20, 40, and 80 meter final coil (#40-1666). Use 6-32 × 3/8" screws and 3/8" fiber flat washers as shown.
- (✓) Now mount this final coil to the RF shield bracket at AG. Use 6-32 × 3/8" screws and #6 lockwashers. Be sure to position the end with the most turns toward tube sockets V1 and V2.
- (✓) Refer to Detail 3J and install the circuit breaker mounting bracket on the RF shield. Use 6-32 × 1/4" hardware with a #6 solder lug at AH.

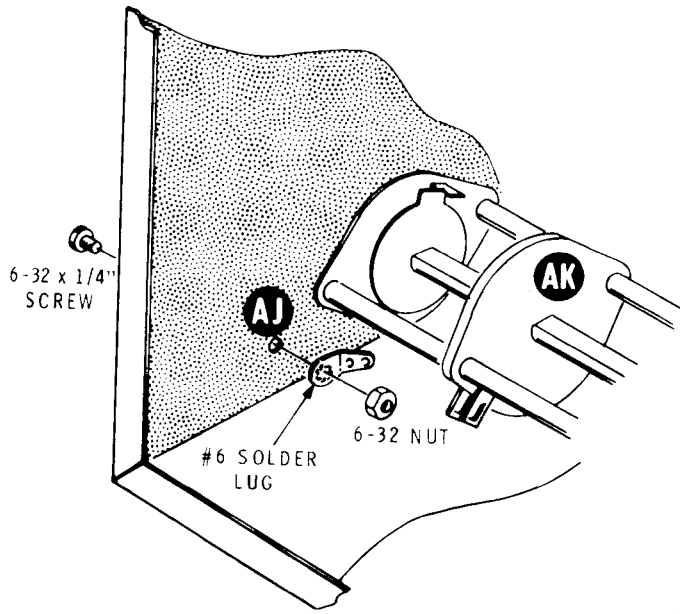

Detail 3G

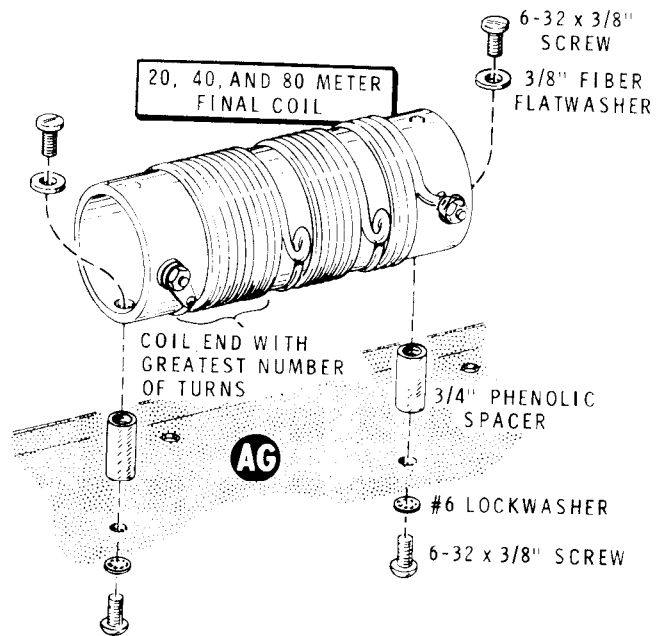

Detail 3H

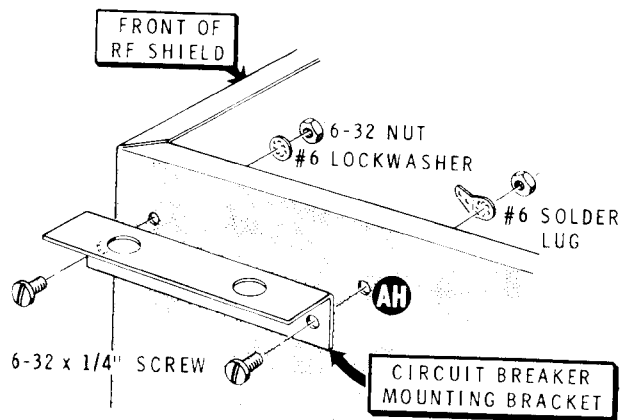

Detail 3J

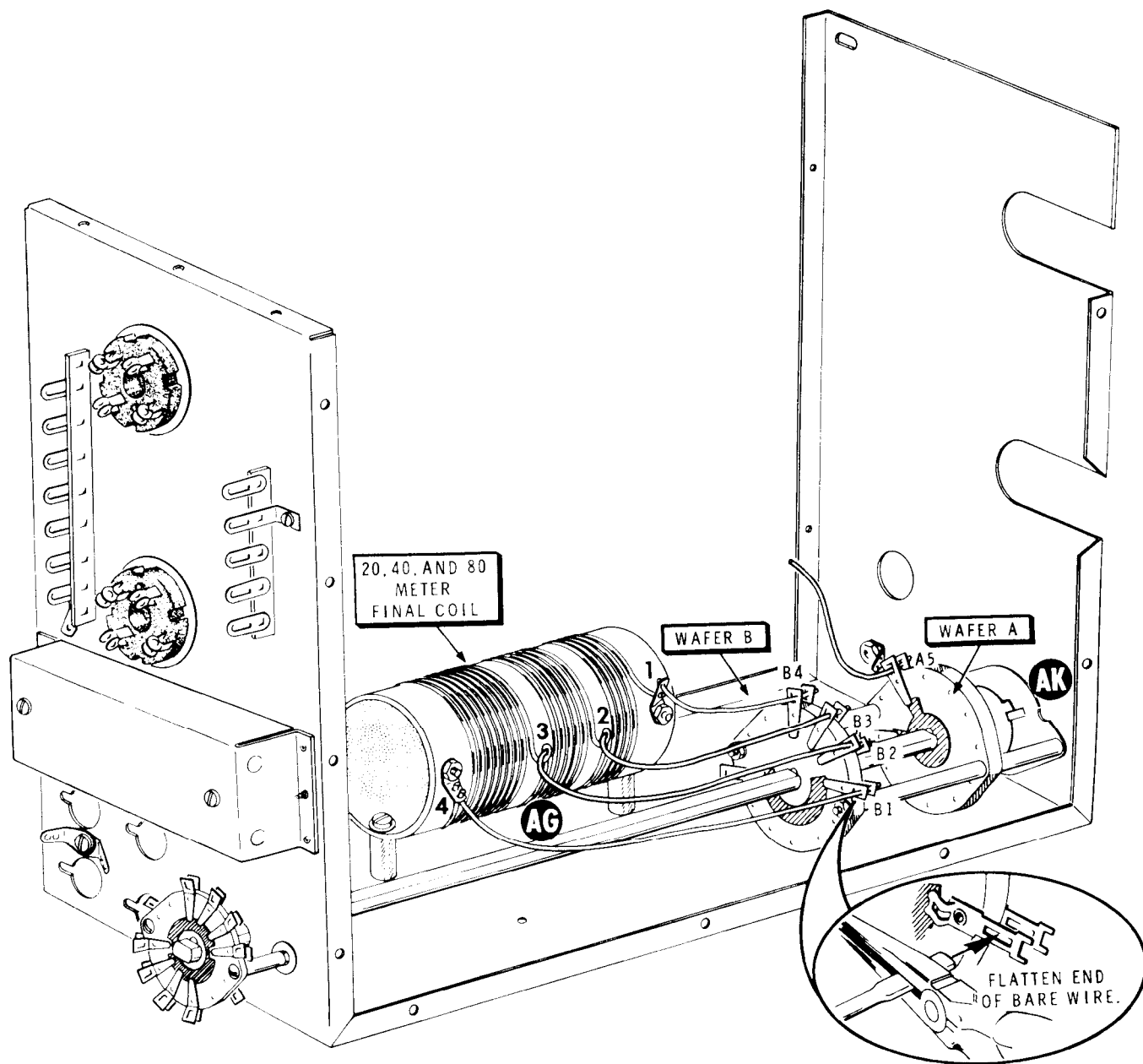

PICTORIAL 4

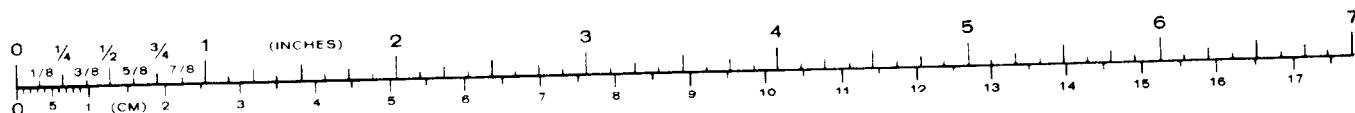

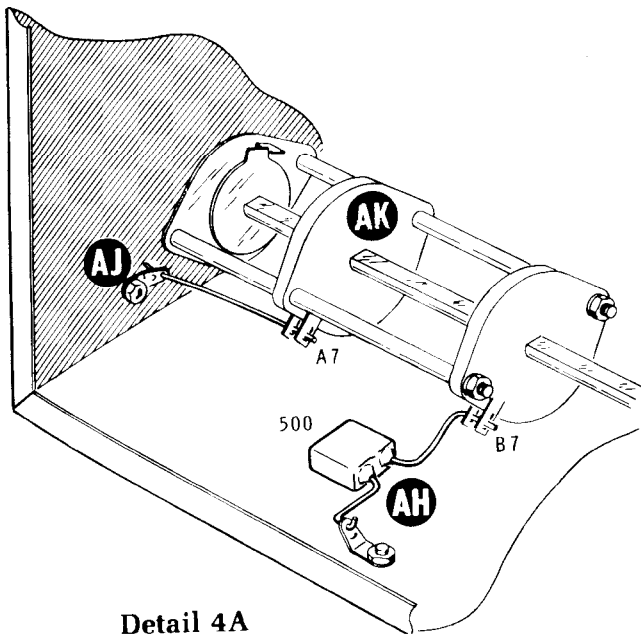

Detail 4A

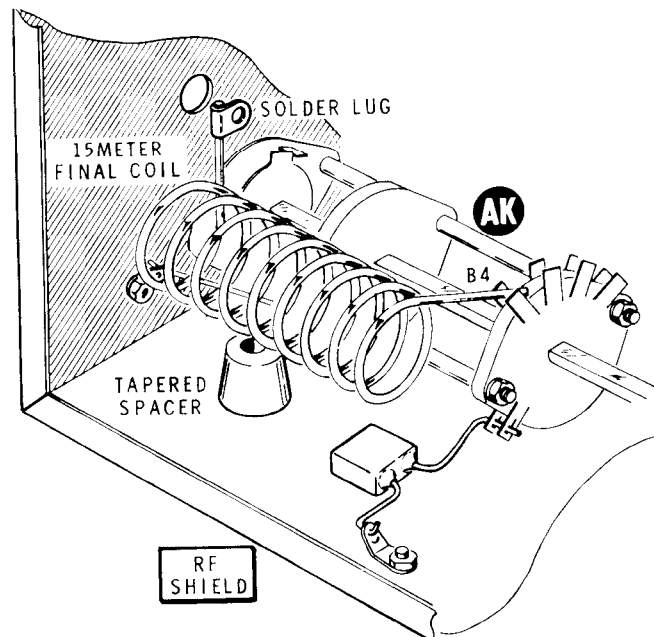

Detail 4B

WIRING — RF SHIELD

Refer to Pictorial 4 for the following steps.

NOTE: The bare wire is too large to fit into the switch lugs. Therefore the end going to the switch lugs should be flattened as shown in the inset drawing of the Pictorial. Pass the wire through both lugs at each position on the switch. Do not attempt to bend this wire around the coil or switch lugs as the coil or switch could be damaged. When soldering connections at switch AK, be sure to solder both lugs at each connection.

- (✓) Connect a 2" bare wire from lug 1 of coil AG (S-1) to lugs B4 of switch AK (NS).
- (✓) Connect a 3" bare wire from lug 2 of coil AG (S-1) to lugs B3 of switch AK (S-1).
- (✓) Connect a 4-1/4" bare wire from lug 3 of coil AG (S-1) to lugs B2 of switch AK (S-1).
- (✓) Connect a 6" bare wire from lug 4 of coil AG (S-1) to lugs B1 of switch AK (NS).
- (✓) Connect one end of a 2" bare wire to lugs A5 of switch AK (S-1). The other end will be connected later.

Refer to Detail 4A for the following steps.

- (✓) Connect a 1-1/2" bare wire from solder lug AJ (S-1) to lugs A7 of switch AK (S-1).
- (✓) Connect a 500 $\mu\mu\text{f}$ 2 kV mica capacitor from solder lug AH (S-1) to lugs B7 of switch AK (S-1).

Refer to Detail 4B for the following steps.

- (✓) Locate the 15 meter final coil (#40-1962).
- (✓) Position a tapered spacer between the RF shield and the coil.

NOTE: In the next step, line up the hole in the solder lug at one end of the coil with the hole in the RF shield as shown in the Pictorial.

- (✓) Position the end of the coil, opposite the solder lug, between lugs B4 of switch AK (S-2).
- (✓) Remove the tapered spacer.

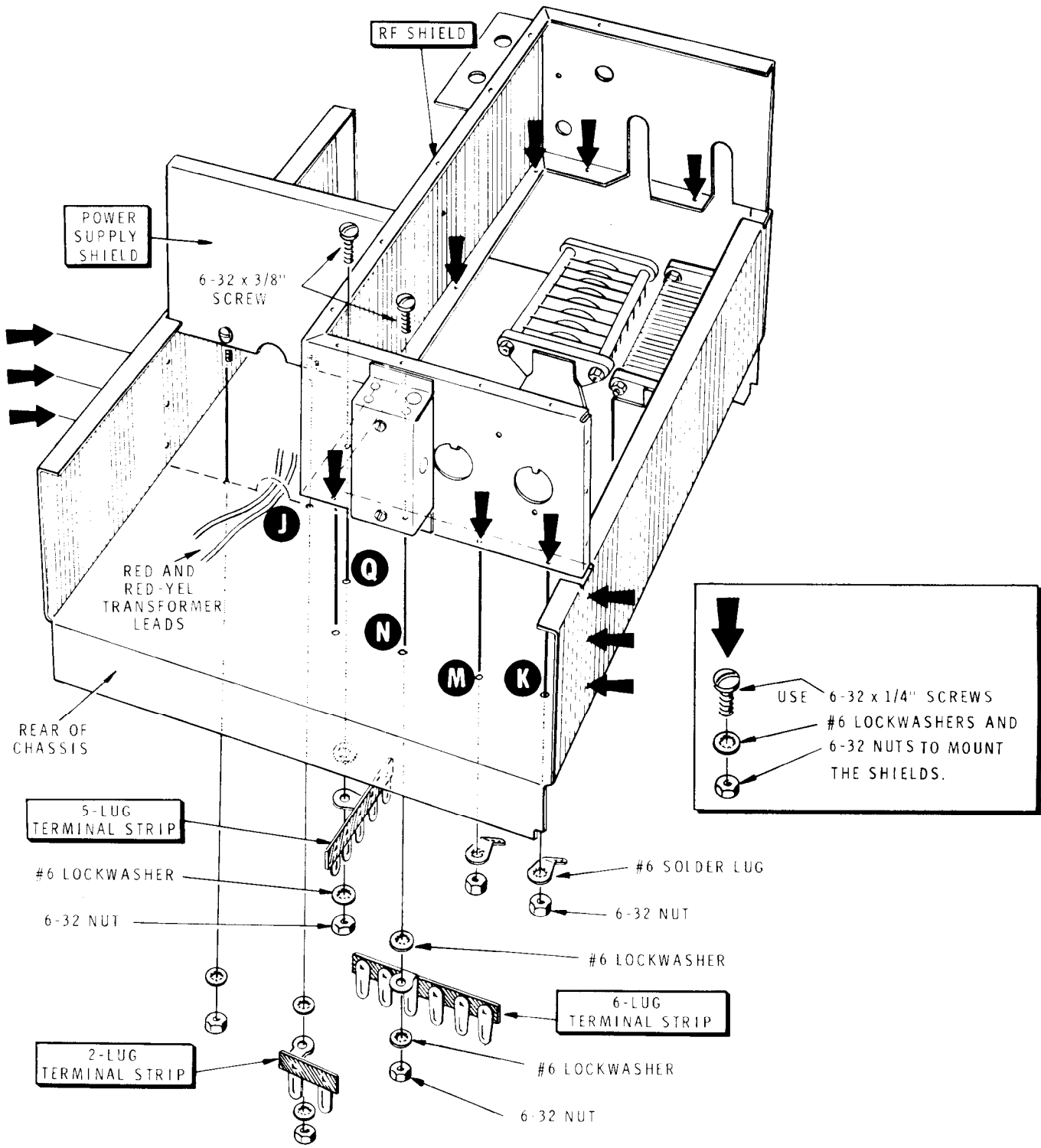

PICTORIAL 5

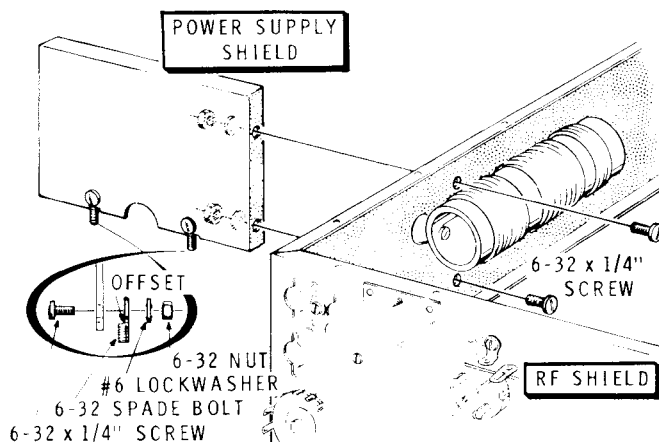

Detail 5A

Refer to Detail 5A and Pictorial 5 for the following steps.

- (✓) Install 6-32 spade bolts on the power supply shield at the locations shown. Use 6-32 × 1/4" hardware. Position the offset in each spade bolt as shown.
- (✓) Install the power supply shield on the RF shield, using 6-32 × 1/4" hardware.

Refer to Pictorial 5 for the following steps.

- (✓) Position the chassis as shown and fit the RF and power supply shield assembly down on the chassis. Be sure to position the red and red-yellow power transformer leads in the notch of the power supply shield. Note: You may have to push the RF shield slightly towards the front of the Amplifier to fit the lip on the shield under the front mounting bracket of the "Tune" capacitor.

- (✓) Secure the RF shield to the chassis. Use 6-32 × 1/4" hardware at all holes indicated by the arrows, with a #6 solder lug at K and M.

- () Install a 6-lug terminal strip at N and a 5-lug terminal strip at Q, using 6-32 × 3/8" hardware. It will be easier to perform this step if the chassis is tipped up on the side next to the transformer. If available, use a magnetized screwdriver to start screws in the hard-to-reach locations.

- () Secure the power supply shield to the chassis, using 6-32 × 1/4" hardware in the holes indicated by the arrows, and #6 lockwashers and 6-32 nuts on the spade bolts with a 2-lug terminal strip at J.

WIRING — CHASSIS BOTTOM

Refer to Pictorial 6 (Illustration Booklet, Page 4) for the following steps.

- () Position the two green power transformer leads through grommet P for connection later.

Connect the remaining power transformer leads as follows:

- (✓) Black-green to lug 2 of terminal strip S (S-1).
- (✓) Black-yellow to lug 3 of terminal strip S (NS).
- (✓) Green-yellow to ground lug 8 of terminal strip S (NS).
- (✓) Shorter blue to ground lug 8 of terminal strip S (NS).
- (✓) Longer blue to lug 5 of terminal strip Q (NS).
- (✓) Black to lug 4 of terminal strip Q (NS).
- (✓) Black-red to lug 2 of terminal strip Q (NS).
- (✓) Position the transformer leads as shown.

NOTE: Use the small solid hookup wire in all wiring steps, unless directed otherwise. Cut the specified color of wire to the length given in the step. Then strip 1/4" of insulation from each wire end, unless directed otherwise.

- (✓) Strip 1/2" of insulation from one end and 1/4" of insulation from the other end of a 4-1/4" gray wire.
- (✓) At the end of this wire with the most insulation removed, pass the wire through lug 10 (S-2) to lug 9 (S-1) of switch B. Connect the other end of the wire to lug 2 of control C (S-1).
- (✓) Connect a 2-1/2" gray wire from lug 13 of switch B (S-1) to lug 3 of control C (S-1).

- (✓) Strip 2-3/4" of insulation from one end and 1/4" of insulation from the other end of a 5" gray wire.
- (✓) At the end with the most insulation removed, pass the wire through lug 3 (S-2), through lug 4 (S-2), through lug 5 (S-2), and through lug 8 (S-2) of switch B to the control solder lug (NS). Connect the other end of the wire to lug 1 of control C (S-1). Be sure the bare portion of the wire does not touch any other lugs or the switch assembly bolt.
- (✓) Connect one end of a 9" gray wire to lug 6 of switch B (S-1). Pass the other end through hole H in the circuit board for connection later.
- (✓) Connect one end of a 7" red wire to lug 12 of switch B (S-1). Pass the other end through hole H in the circuit board for connection later.
- (✓) Connect one end of a 4" yellow wire to lug 2 of switch B (S-1). Pass the other end through hole H in the circuit board for connection later.
- (✓) Connect a 4-3/4" yellow wire from lug 2 of terminal strip N (NS) to lug 4 of relay L (S-1).
- (✓) Connect a 4" yellow wire from lug 5 of terminal strip N (NS) to lug 3 of relay L (NS).
- (✓) Connect a 3" yellow wire from lug 6 of terminal strip N (NS) to the lug of terminal strip V (NS).
- () Connect one end of a 7" green wire to lug 1 of terminal strip N (NS). Pass the other end through grommet P for connection later.
- (✓) Refer to the inset drawing on Pictorial 6 and connect one end of a 10" large blue wire to the diode lead (point A) extending from the circuit board (S-1). Pass the other end through grommet F for connection later. Cut off the excess diode lead.
- (✓) Locate the cable assembly and position it on the chassis as shown.





Connect the wires from BO (Breakout) #1 to switch A as follows:

- (✓) Shorter red to lug 1 (S-1).
- (✓) Longer red to lug 2 (S-1).
- (✓) Shorter black to lug 3 (S-1).
- (✓) Longer black to lug 4 (S-1).
- (✓) Pass all the wires from BO#2, except the blue, green, yellow, and the two shielded cables, down through hole H in the circuit board for connection later.

Connect the wires from BO#2 to switch B as follows:

- (✓) Green to lug 1 (S-1).
- (✓) Yellow to lug 7 (S-1).
- (✓) Bend lugs 5, 6, and 7 of switch B over as they are shown in the inset drawing. Be sure lugs 6 and 7 do not touch the mounting screw.

NOTE: When soldering the shielded cable connections, do not overheat the connection as the insulation on the inner conductor will melt and permit a short to the shield. It may be easier to make these connections if the switch nut is loosened and the switch turned temporarily. Return the switch to the proper position after the connections are soldered.

- (✓) Inner lead of the unmarked shielded cable to lug 15 (S-1) and the shield to the control solder lug (NS).
- (✓) Inner lead of the shielded cable with red band to lug 14 (S-1) and the shield to the control solder lug (S-3).
- (✓) Blue to lug 11 (S-1).
- (✓) Connect the blue wire from BO#3 to lug 2 of terminal strip J (NS).

Connect the wires from BO#4 to terminal strip Q as follows:

- (✓) Red to lug 2 (S-2).
- (✓) Both black to lug 4 (S-3).
- (✓) Inner lead from the shielded cable to lug 1 (NS) and the shield to lug 3 (NS).

Connect the following wires from BO#5 to terminal strip S.

- (✓) Yellow to lug 7 (NS).
- (✓) Red to lug 4 (NS).
- (✓) Small black to lug 3 (S-2).
- (✓) Large black to lug 1 (NS).
- (✓) Violet to lug 6 (NS).
- (✓) Pass the violet, gray, brown, and white wires from BO#6 through grommet P for connection later.

Connect the following wires from BO#6 to terminal strip N.

- (✓) Inner lead of the shielded cable to lug 3 (NS) and the shield to lug 4 (NS).
- (✓) Both yellow to lug 2 (NS).
- (✓) Green to lug 1 (NS).
- (✓) Twist together the two black wires from BO#6 as shown. Connect either wire to lug 1 (S-1) and the other to lug 2 (S-1) on the motor.

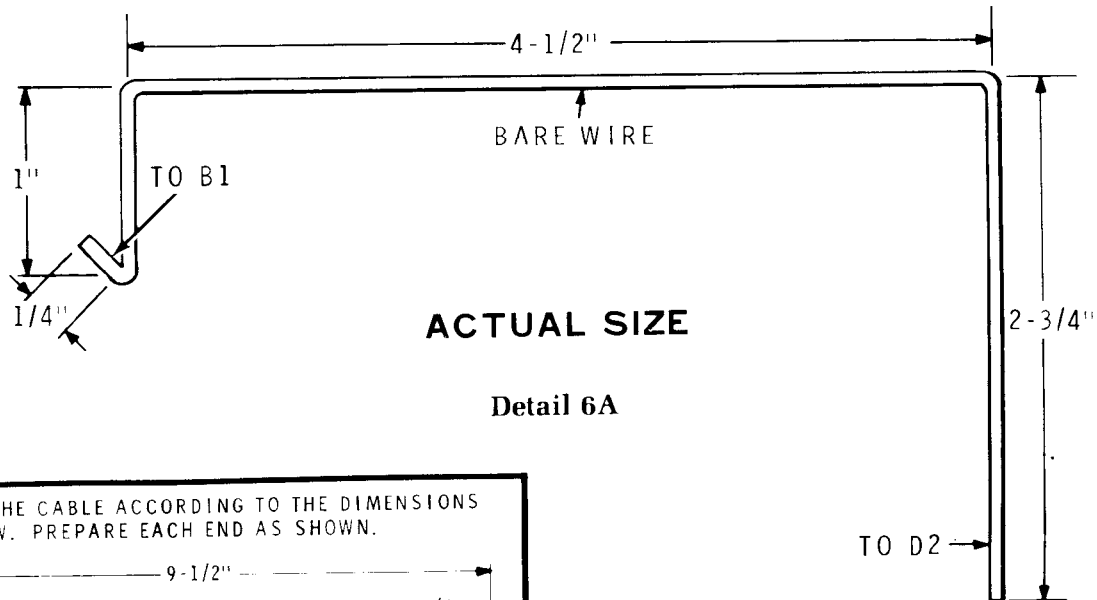

ACTUAL SIZE

Detail 6A

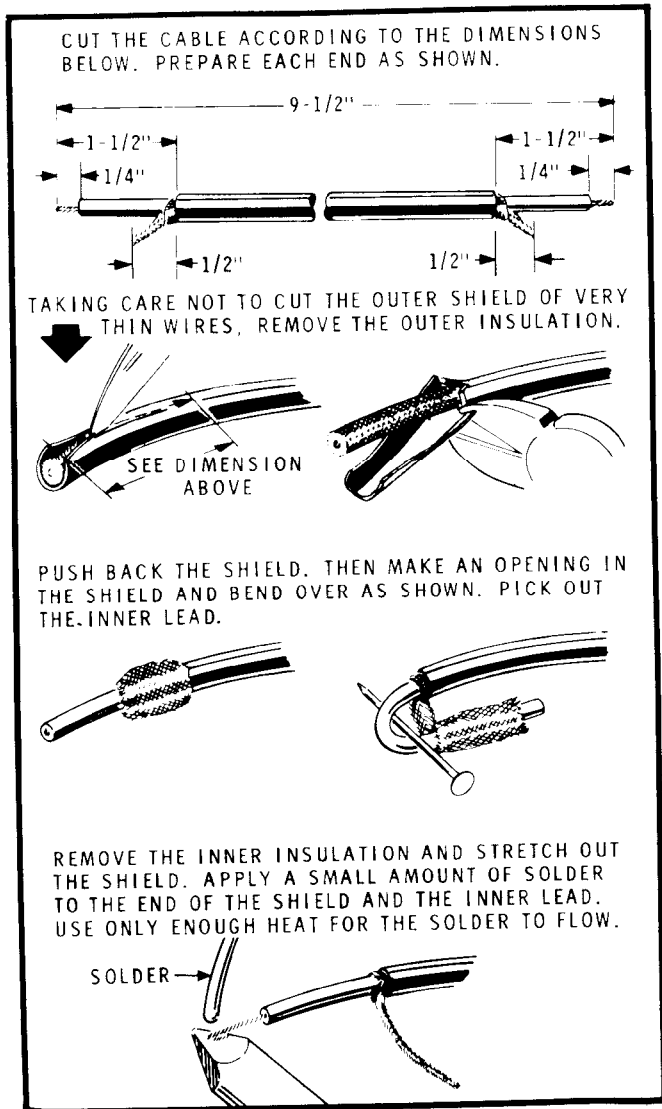

Detail 6B

- (✓) Refer to Detail 6A and bend an 8-1/2" length of bare wire to the shape shown. The Detail is full-size and may be used as a pattern.
- (✓) Connect the end with the short bend, through the hole in the chassis, to lugs B1 of switch AK (S-2).
- (✓) Route the other end through grommet I. It will be connected later.

CAUTION: Be sure the bare wire just installed does not touch the chassis.

- (✓) Refer to Detail 6B and prepare a 9-1/2" length of large (RG-58A/U) shielded cable.
- (✓) At either end of the prepared cable, connect the inner lead to lug 7 of relay L (S-1) and the shield to solder lug K (NS).
- (✓) At the other end of the cable, connect the inner lead to the bare wire near grommet I (S-1) and the shield to solder lug E (NS), as shown.



CUT THE CABLE ACCORDING TO THE DIMENSIONS BELOW. PREPARE EACH END AS SHOWN.

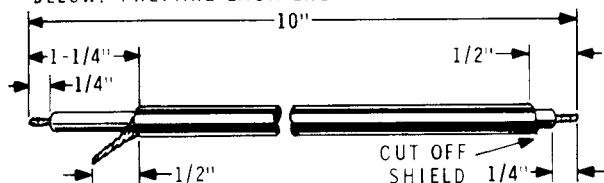

Detail 6C

- (✓) Refer to Detail 6C and prepare a 10" length of large (RG-58A/U) shielded cable.
- (✓) At the end of the prepared cable with shield, connect the inner lead to lug 8 of relay L (S-1) and the shield to solder lug K (S-2).
- (✓) Pass the other end of the cable behind relay L and through grommet BA for connection later.
- (✓) Connect the 1.1 mh RF choke (#45-4) from the bare wire (S-1) to solder lug E (S-2). Position the choke as shown with about 1/2" spacing between it and the chassis.

- (✓) Connect a .02 μ fd ceramic capacitor between lugs 3 (NS) and 4 (NS) of terminal strip N.

Refer to Pictorial 7 (Illustration Booklet, Page 5) for the following steps.

NOTE: All resistors are 1/2 watt, unless specified otherwise.

- (✓) Connect a 4700 Ω (yellow-violet-red) resistor from lug 1 of phono socket Z (NS) to lug 6 of terminal strip S (S-2).
- (✓) Connect a .02 μ fd ceramic capacitor between lugs 1 (S-2) and 2 (S-1) of phono socket Z.
- (✓) Connect a .02 μ fd ceramic capacitor between lugs 1 (NS) and 2 (S-1) of phono socket Y.
- (✓) Connect a .005 μ fd 1.4 kV ceramic capacitor between lugs 5 (S-1) and 1 (NS) of terminal strip S.

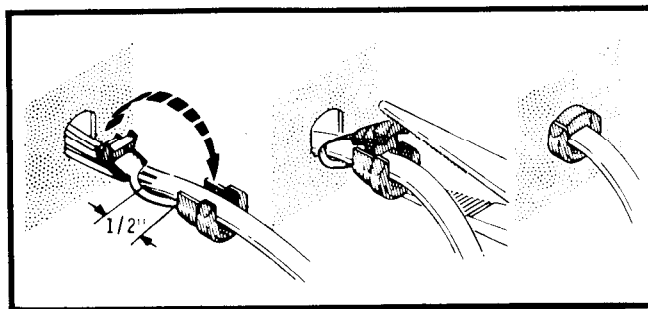

Detail 7A

- (✓) Connect a .005 μ fd 1.4 kV ceramic capacitor between lugs 4 (NS) and 8 (S-3) of terminal strip S.
- () Locate the line cord and separate the three leads for 4".
- (✓) Refer to Detail 7A and install the line cord in the large hole in the rear corner of the chassis. Use the line cord strain relief. Position the strain relief approximately 1/2" from the point where the wires separate.

Connect the leads of the line cord as follows. Cut each lead to the required length to reach its connecting point.

- (✓) Green to solder lug BB (S-1).
- (✓) Either gray (or black) to terminal strip S lug 1 (S-3).
- (✓) Other gray (or black) to terminal strip S lug 4 (S-3).
- (✓) Connect a 33 Ω 1 watt (orange-orange-black) resistor from lug 1 of phono socket Y (S-2) to lug 7 of terminal strip S (S-2).
- (✓) Connect a .02 μ fd ceramic capacitor between lugs 1 (NS) and 3 (NS) of terminal strip Q.
- (✓) Connect the positive (+) lead of a 20 μ fd electrolytic capacitor to lug 3 of terminal strip Q (S-3) and the other lead to lug 5 of terminal strip N (NS). Use small sleeving on the lead to terminal strip N.

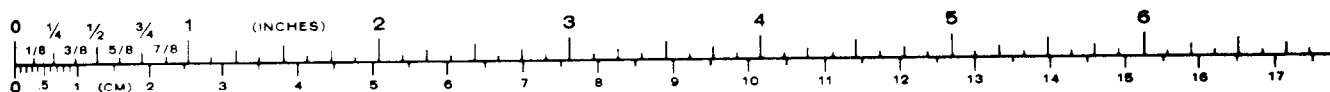

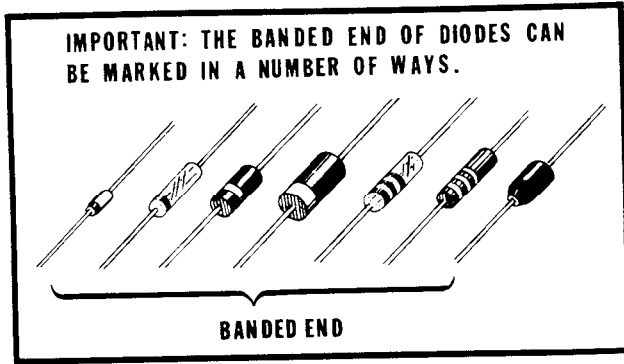

Detail 7B

- (✓) Refer to Detail 7B and connect the lead from the banded end of a silicon diode #57-27 to lug 6 (S-2) and the other lead to lug 5 (NS) of terminal strip N.
- (✓) Connect the positive (+) lead of a 2 μ fd electrolytic capacitor to lug 4 (NS) and the other lead to lug 2 (NS) of terminal strip N.
- (✓) Connect a 10 k Ω (brown-black-orange) 2 watt resistor between lugs 4 (S-4) and 5 (S-4) of terminal strip N.
- () Connect a 1.5 Ω (brown-green-gold-silver) resistor between lugs 2 (NS) and 1 (NS) of terminal strip N.
- () Connect a .02 μ fd ceramic capacitor between lug 1 of terminal strip N (S-4) and solder lug M (NS).
- (✓) Refer to Detail 7C and prepare a resistor combination using three 4.7 megohm (yellow-violet-green) 1 watt resistors and the large sleeving.
- (✓) Connect this resistor combination from lug 2 of terminal strip J (NS) to point B on the foil of the circuit board. Solder the lead directly to the foil. Use sleeving on the lead to the circuit board.

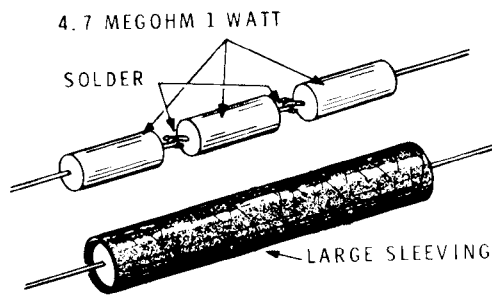

Detail 7C

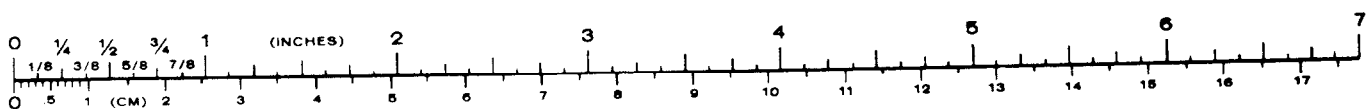

- (✓) Connect a 15 k Ω (brown-green-orange) resistor between lugs 1 (S-1) and 2 (S-3) of terminal strip J.

This Linear Amplifier may be operated from either 120 volts or 240 volts AC. Perform one of the following two steps, depending on the line voltage to be used. Refer to the inset drawing on Pictorial 7.

- (✓) For 120 volt AC operation, connect one bare wire under screws 1 and 2, and another bare wire under screws 3 and 4 of terminal strip S.
- () For 240 volt AC operation, connect a bare wire under screws 2 and 3 of terminal strip S.

WIRING — SWR BRIDGE

NOTE: Position the chassis on the rear apron for the following steps.

- (✓) Refer to Pictorial 8 (Illustration Booklet, Page 6) and Detail 8A, and install the coaxial cavity using 4-40 \times 5/16" hardware and two 5/16" steel flat washers. Be sure no wires are pinched between the cavity and the chassis.

Refer to Pictorial 8 (Illustration Booklet, Page 6) and Detail 8B for the following steps.

- (✓) Slide the three plastic spacers on the RF driver element. Be sure the two small holes in each spacer are positioned correctly. Position the spacers approximately as shown.
- (✓) Insert the two RF pickup elements through the plastic spacers as shown. Then position this assembly in the coaxial cavity.
- (✓) Refer to the inset drawing of Detail 8B and solder the RF driver element to coaxial socket X (S-1) and standoff U (S-1).
- (✓) Refer to the inset drawing on Pictorial 8 and cut the flexible lead at lug 10 of relay L. Cut it as close to the lug as possible.
- (✓) Carefully remove the sleeving from this lead. Then cut the lead to 1-1/4" and the sleeving to 1" in length. Replace the sleeving on the lead.

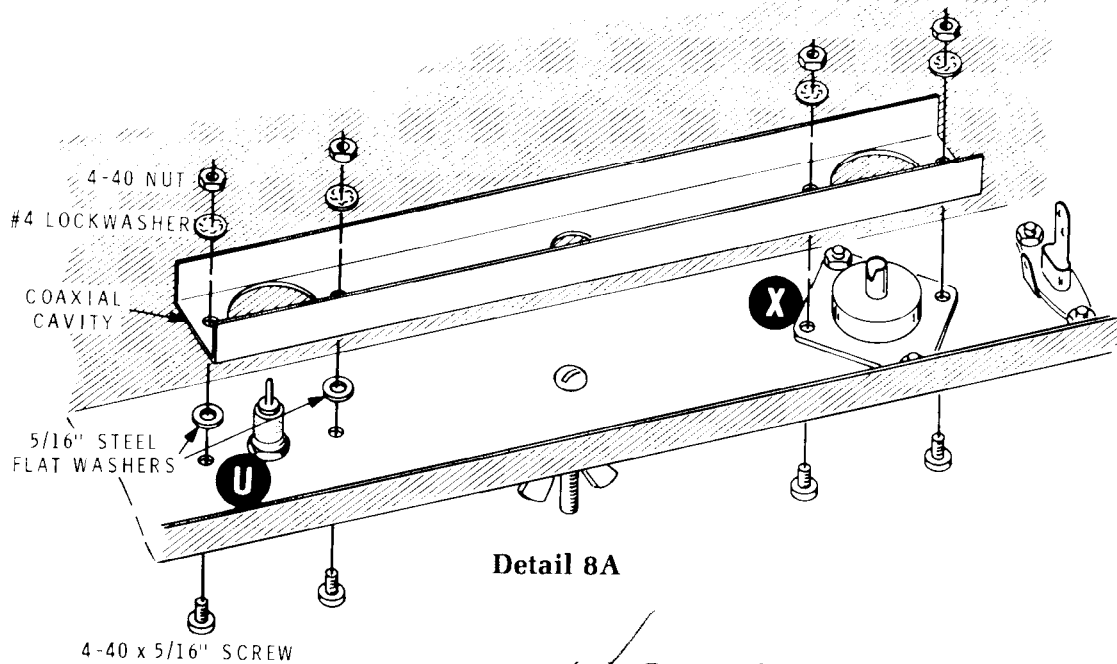

Detail 8A

- (✓) Connect this lead to coaxial socket T (S-1).
- (✓) In a like manner, cut the flexible lead at lug 9 of relay L.
- (✓) Remove the sleeving from this lead. Then cut the lead to 1-1/4" and the sleeving to 1" in length. Replace the sleeving on this lead.

- (✓) Connect the end of this lead in the hole at 5 of the RF driver element (S-1).
- (✓) Connect a 1-1/2" bare wire between lugs 5 (S-1) and 6 (S-1) of relay L. Be sure this wire is positioned below the top edge of the relay so it will not short to the cabinet later.

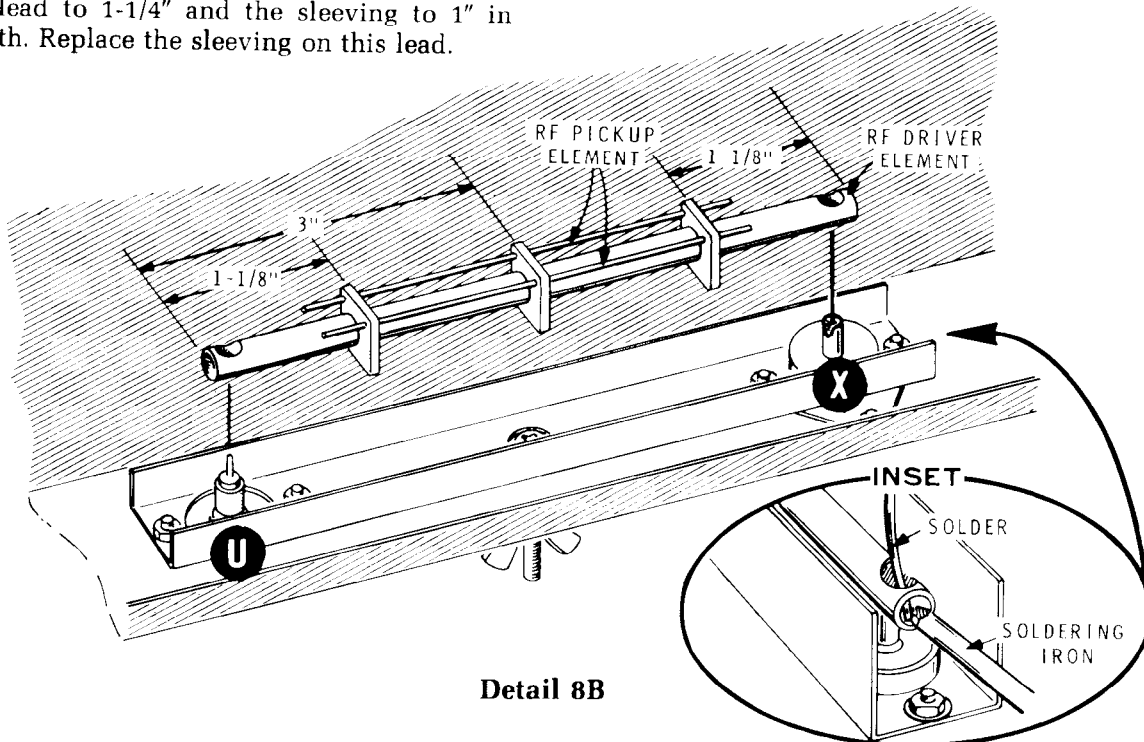

Detail 8B

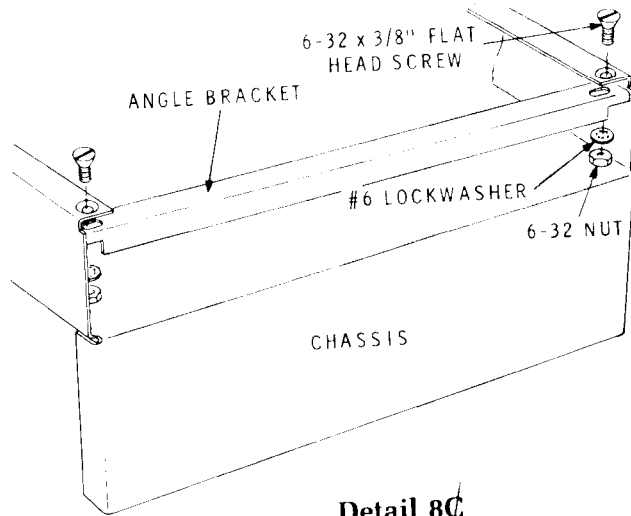

Detail 8C

NOTE: When soldering leads to the RF pickup elements in the next four steps, slide the plastic spacer away from the area being soldered. Then, reposition the spacer after the connection has cooled to prevent melting the spacers. **Be sure to connect the component leads to the proper RF pickup element.**

- () Connect a 100 Ω (brown-black-brown) resistor from #1 on the RF pickup element (S-1) to solder lug R (S-1). Connect the resistor lead at the very end of the RF pickup element. Position the resistor as shown.

CAUTION: When soldering the leads of the small silicon and crystal diodes, grip the lead between the connection and the body of the diode with a pair of long-nose pliers. This will protect the diodes from heat damage. By placing a rubber band around the handles of the pliers and clipping the pliers onto the diode lead, you will have both hands free for soldering.

- () Cut both leads of a crystal diode (brown-white-brown) to 1/2". Connect the cathode (color band end) lead to lug 1 of terminal strip Q (S-3) and the other lead at #2 of the RF pickup element (S-1). Be sure the diode lead is positioned 5/8" from the end of the RF pickup element.

- () Connect a 100 Ω (brown-black-brown) resistor from #4 of the RF pickup element (S-1) to the solder lug M (S-2). Connect the resistor lead at the very end of the RF pickup element. Position the resistor as shown.

- (✓) Cut both leads of a crystal diode (brown-white-brown) to 5/8". Connect the cathode (color band end) lead to lug 3 of terminal strip N (S-3) and the other lead at #3 of the RF pickup element (S-1). Be sure the diode lead is positioned 5/8" from the end of the RF pickup element.

- (✓) Connect a 465 Ω 15 watt resistor from lug 5 of terminal strip Q (S-2) to the lug of terminal strip V (S-2).

- (✓) Connect a 2000 Ω 7 watt resistor from lug 2 of terminal strip N (S-6) to lug 3 of relay L (S-2). Position the body of the resistor down against the chassis.

- () Refer to Detail 8C and install the angle brackets using 6-32 × 3/8" flat head hardware.

- (✓) Remove the protective backing from a DANGER label and press it firmly in place on the underside of the chassis as shown.

This completes the wiring under the chassis. Check to see that all connections are soldered. Shake out any wire clippings and solder splashes.

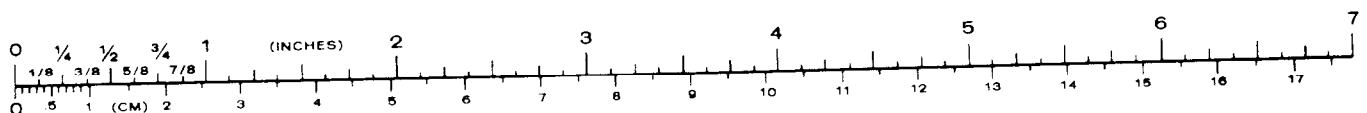

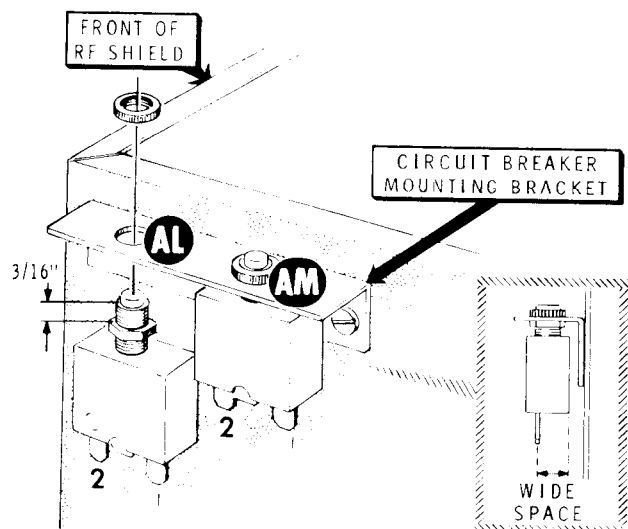

Detail 9A

WIRING — CHASSIS TOP

Refer to Pictorial 9 (Illustration Booklet, Page 7) for the following steps.

Connect the power transformer leads to the circuit board as follows:

- () Red to RED (S-1).
- () Red-yellow to RED-YEL (S-1).

Connect the wires extending from hole H of the circuit board as follows:

- () Short gray coming from the cable assembly to hole D of the circuit board (S-1).
- () Yellow coming from switch B to hole C of the circuit board (S-1).

NOTE: The circuit breakers will be mounted after they are wired.

- () Either large black coming from the cable assembly to lug 1 of the circuit breaker (S-1).
- () Other large black to lug 2 of this circuit breaker (S-1).
- () Either large red coming from the cable assembly to lug 1 of the other circuit breaker (S-1).
- () Other large red to lug 2 of this circuit breaker (S-1).

Refer to Detail 9A for the following steps.

- () Remove the round nut from both circuit breakers.
- () Adjust the hex nut so it is 3/16" from the end of the threaded bushing on each circuit breaker.
- () Install the circuit breaker with the black wires connected to it, at AM on the circuit breaker mounting bracket. Use the round nut removed from the circuit breaker. Be sure the wide space is between the circuit breaker lug and the bracket.
- () In a like manner, install the circuit breaker with the red wires connected to it at AL of the circuit breaker bracket. Again position the wide space between the lug and bracket.
- () Locate the 100 μf tubular capacitor and mount a #6 solder lug with a 6-32 \times 3/16" screw to one end of this capacitor as shown in Detail 9B.
- () Now mount this capacitor to the capacitor mounting bracket, using a 6-32 \times 1/4" screw and a #6 lockwasher as shown in Detail 9B.
- () Place the capacitor mounting bracket on the bolt at #1 of variable capacitor G.
- () Fit the solder lug on the end of the 15 meter final coil on the bolt at #1 of variable capacitor G. Secure it and the capacitor mounting bracket with a #6 lockwasher and a 6-32 nut.
- () Connect the end of the wire coming from lugs A5 of switch AK to the lug of the 100 μf tubular capacitor mounted on lug 1 of variable capacitor G (S-1).

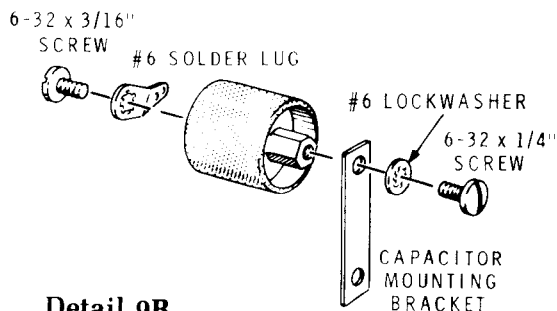

Detail 9B

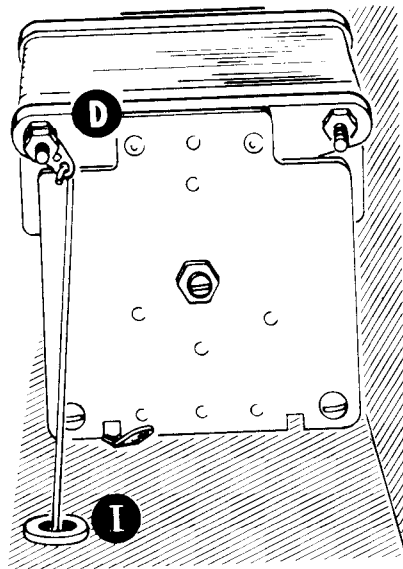

Detail 9C

Refer to Detail 9C and install a #10 solder lug on the indicated lug of capacitor D with a 10-32 nut. Then connect the bare wire coming through grommet I to this solder lug (S-1).

Refer to Detail 9D and install a 1000 μmf tubular capacitor onto the bolt at #2 of variable capacitor G as follows:

1. Place a #6 lockwasher onto the bolt.
2. Turn a 6-32 stud onto the bolt.
3. Thread the 1000 μmf tubular capacitor onto the stud.

Install a #6 solder lug at AP on the tubular ceramic capacitor, using a 6-32 \times 3/16" screw. Position the solder lug as shown.

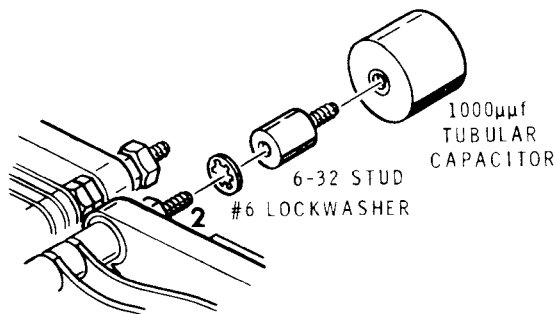

Detail 9D

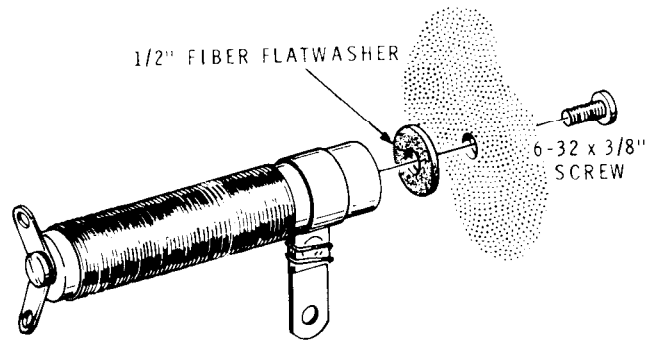

Detail 9E

Cut one lead of a .001 μfd 3 kV ceramic capacitor to 1/2".

Connect the 1/2" lead of this capacitor to solder lug E (S-1). The other lead will be connected later.

Refer to Detail 9E and install the 50 μH RF choke (#45-61) at AN, using a 6-32 \times 3/8" screw and a 1/2" fiber flat washer. NOTE: Use the hole closest to the rear of the Amplifier.

Connect the lead of the .001 μfd ceramic capacitor coming from solder lug E to lug 1 of RF choke AN (NS).

Connect the end of the large blue wire coming from grommet F to lug 1 of RF choke AN (S-2).

Connect a 1-1/4" bare wire from lug 2 of RF choke AN (S-1) to solder lug AP (NS).

Refer to Detail 9F and prepare two anode clip and RF choke combinations. Use anode clips and parasitic RF chokes (#45-53) as shown.

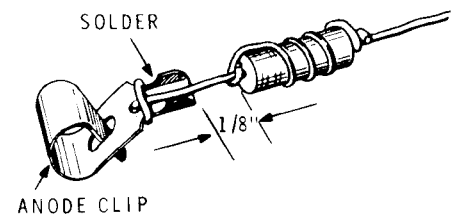

Detail 9F

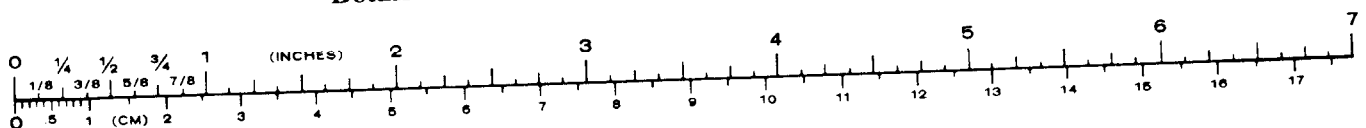

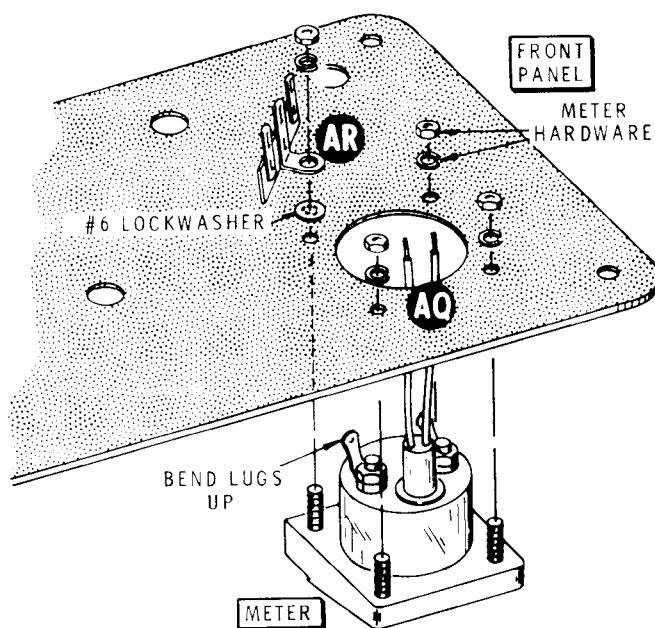

Detail 9G

- (✓) Install the 572-B or T160-L tubes in tube sockets V1 and V2.
 - (✓) Install an anode clip and RF choke combination on the cap of each tube as shown in the inset drawing in Pictorial 9.
 - (✓) Connect the free choke lead of one of these combinations to solder lug AP (NS). Position the combination as shown.
 - (✓) Connect the free choke lead of the other combination to solder lug AP (S-3). Position the combination as shown.
 - (✓) Refer to Detail 9G and install the meter at AQ on the front panel with a 3-lug terminal strip at AR. Use a #6 lockwasher plus the lockwashers and nuts supplied with the meter. Bend the lugs of the meter upward, as shown.
 - (✓) Remove the shorting clip from between the meter lugs.
 - (✓) Connect a .02 μ fd ceramic capacitor between lugs 1 (NS) and 2 (NS) of meter AQ.
 - () Remove the control nuts from the two switches and the control on the front of the chassis.
 - () Position the front panel in front of the chassis.
- Connect the wires extending from hole H of the circuit board as follows:
- () Red to lug 2 of meter AQ (S-2).
 - () Long gray to lug 1 of meter AQ (S-2).
 - (✓) White to lug 1 of terminal strip AR (NS).
 - (✓) Brown to lug 3 of terminal strip AR (NS).
 - (✓) Connect the white lead from the meter pilot lamp socket to lug 1 of terminal strip AR (S-2).
 - () Connect the black lead from the meter pilot lamp socket to lug 3 of terminal strip AR (S-2).

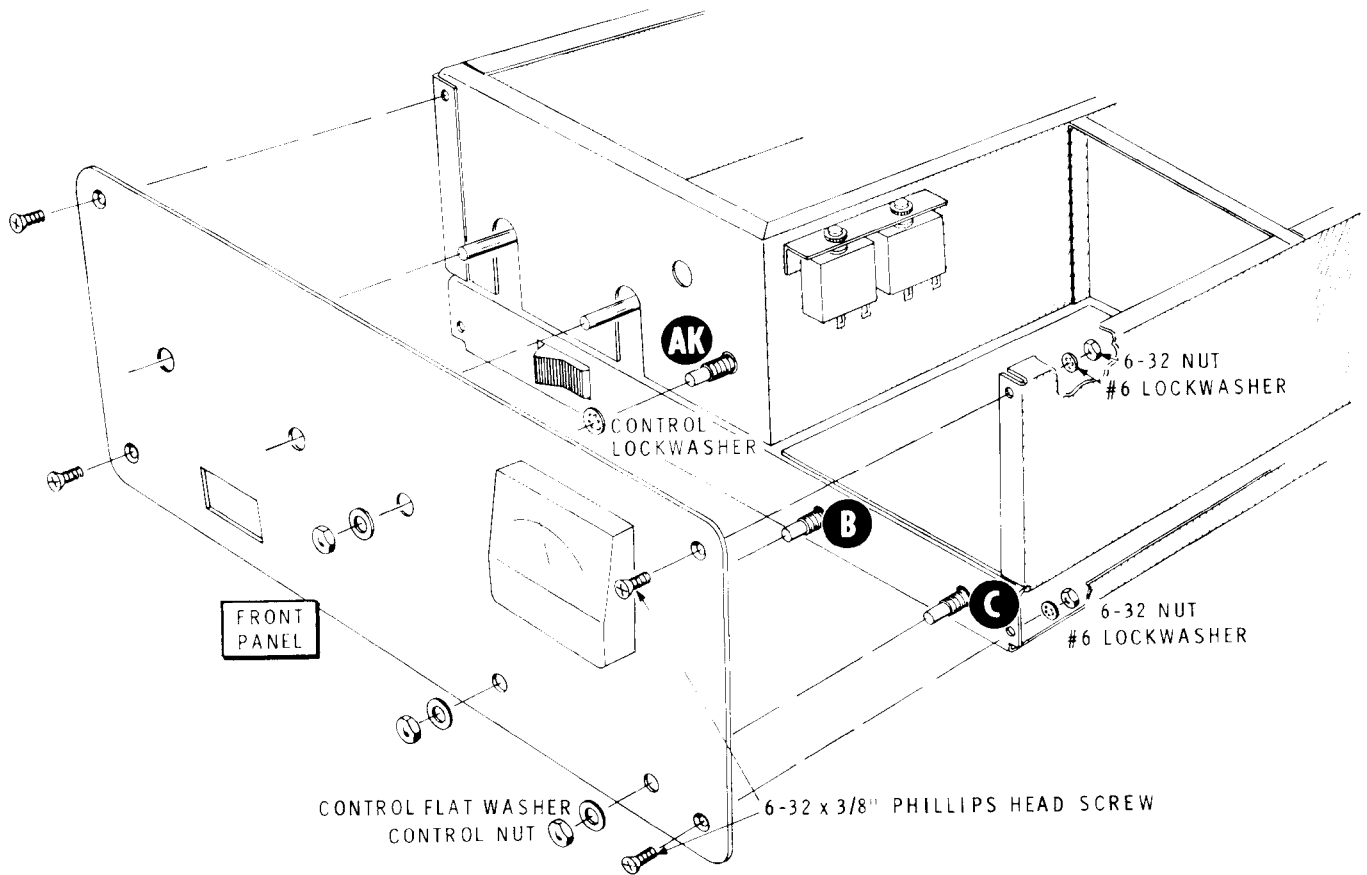

Detail 9H

- () 1. Refer to Detail 9H for the next three steps. Install the front panel on the chassis with a control lockwasher, a control flat washer, and a control nut at AK, and with control flat washers and control nuts at B and C. Do not tighten the nuts at this time.
- () 2. Secure the four corners of the front panel to the chassis, using 6-32 × 3/8" phillips head hardware. Do not tighten at this time.
- () 3. Now center the front panel so the rocker switch works freely. Tighten the three control nuts and the hardware at the corners of the front panel.

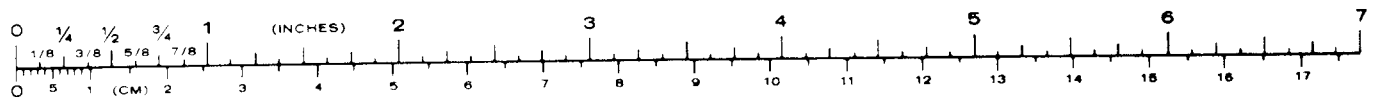



FINAL WIRING

Refer to Pictorial 10 (Illustration Booklet, Page 7) for the following steps.

- (✓) Connect the wire coming from grommet BC to lug C6 of switch AK (S-1).
- (✓) Connect the wire coming from grommet BD to lug 2 of tube socket V2 (NS).
- (✓) Connect the inner lead of the shielded cable coming from grommet BA to lug C12 of switch AK (S-1). The shield is not used at this end of the cable.

Connect the wires coming from grommet P as follows:

- (✓) Either green power transformer lead to lug 3 of terminal strip M. Use the **lower** hole of lug 3 (S-1).
- (✓) Other green power transformer lead to lug 5 of terminal strip M. Use the **lower** hole of lug 5 (S-1).
- (✓) Brown to lug 3 of terminal strip M (NS).
- (✓) White to lug 5 of terminal strip M (NS).
- (✓) Green to lug 7 of terminal strip AA (NS).
- (✓) Violet to lug 3 of terminal strip AA (NS).
- (✓) Gray to lug 2 of terminal strip AA (NS).
- (✓) Connect a 33 Ω (orange-orange-black) 1 watt resistor from lug 3 of tube socket V2 (NS) to lug 4 of terminal strip AA (NS).
- (✓) Connect one end of a 33 Ω (orange-orange-black) 1 watt resistor through lug 2 (NS) to lug 3 (S-1) of tube socket V1. Connect the other end to lug 4 of terminal strip AA (NS).
- (✓) Connect a 4700 Ω (yellow-violet-red) resistor between lugs 1 (NS) and 3 (NS) of terminal strip AA.
- (✓) Connect the cathode (band end) lead of a 1N458 silicon diode (yellow-green-gray) to lug 2 (NS) and the other lead to lug 1 (NS) of terminal strip AA.

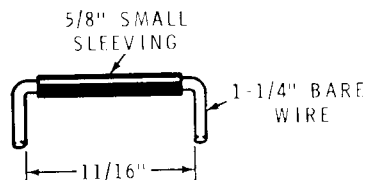

Detail 10A

- (✓) Connect a 5 μf ceramic capacitor from lug 1 of terminal strip AA (NS) to lug 2 of tube socket V1 (NS).

- ~~(✓)~~ Connect a 3300 Ω (orange-orange-red) 1 watt resistor between lugs 4 (NS) and 7 (NS) of terminal strip AA.

- (✓) Connect the 28 μh RF choke (#45-18) between lugs 4 (S-4) and 7 (NS) of terminal strip AA.

- (✓) Cut a bare wire to 1-1/4". Place a 5/8" length of small sleeving on this wire. Refer to Detail 10A and bend the ends of the wire down as shown. Then connect this wire between lug 2 and lug 4 of terminal strip M. Use the lower holes of each lug. Solder both connections.

- (✓) Connect a .02 μfd ceramic capacitor between lugs 4 (S-1) and 5 (NS) of terminal strip M.

- (✓) Refer to Detail 10B, and install the (#40-1980) coil at CA. Press on the coil until the retaining clips snap into place.

- (✓) In a like manner, install the (#40-593) coil at CB.

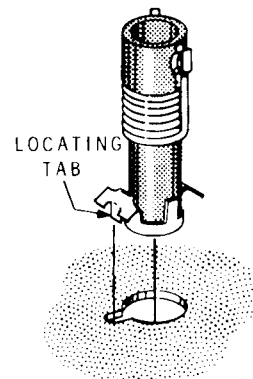

Detail 10B

- Install the (#40-727) coil at CC.
- Install the (#40-591) coil at CD.
- Connect a 270 $\mu\mu\text{f}$ mica capacitor from lug 1 of coil CD (NS) to lug 2 of solder lug AD (NS).
- Connect a 240 $\mu\mu\text{f}$ mica capacitor from lug 2 of coil CB (NS) to lug 2 of solder lug AD (S-2).
- Connect a 470 $\mu\mu\text{f}$ mica capacitor from lug 1 of coil CA (NS) to lug 1 of solder lug AD (NS).
- Connect a 180 $\mu\mu\text{f}$ mica capacitor from lug 1 of coil CB (NS) to lug 1 of solder lug AD (S-2).

NOTE: When you connect wires to the remaining lugs of switch AK, be sure to solder both lugs at each location.

- Connect a 1-1/4" gray wire from lug 2 of coil CD (S-1) to lugs C7 of switch AK (S-1).
- Connect a 3" gray wire from lug 2 of coil CB (S-2) to lugs C3 of switch AK (S-1).
- Connect a 3-1/4" gray wire from lug 2 of coil CA (S-1) to lugs C2 of switch AK (S-1).
- Connect a 2-1/4" gray wire from lug 2 of coil CC (S-1) to lugs C4 of switch AK (S-1).

Refer to Pictorial 11 for the following steps.

- Connect a 3-1/2" gray wire from lug 1 of coil CA (S-2) to lugs C8 of switch AK (S-1).
- Connect a 3" gray wire from lug 1 of coil CD (S-2) to lugs C1 of switch AK (S-1).
- Connect a 2-1/4" gray wire from lug 1 of coil CC (S-1) to lugs C10 of switch AK (S-1).
- Connect a 3-1/4" gray wire from lug 1 of coil CB (S-1) to lugs C9 of switch AK (S-1).
- Connect a 200 $\mu\mu\text{f}$ mica capacitor from lug 3 of tube socket V2 (S-2) to solder lug AC (NS).
- Connect a .02 μfd ceramic capacitor between lug 2 of terminal strip AA (S-3) and lug 1 of solder lug AB (NS).

- Connect a .02 μfd ceramic capacitor between lug 3 of terminal strip AA (S-3) and lug 1 of solder lug AB (NS).
- Connect an 18 $\mu\mu\text{f}$ ceramic capacitor between lug 1 of terminal strip AA (S-4) and lug 1 of solder lug AB (S-3).
- Connect a .02 μfd ceramic capacitor between lug 7 of terminal strip AA (S-4) and solder lug AC (S-2).
- Connect a 2-1/4" bare wire from lug 4 of tube socket V2 (NS) to lug 1 of tube socket V1 (NS).
- Connect a 2-1/4" bare wire from lug 1 of tube socket V2 (NS) to lug 4 of tube socket V1 (NS).
- Connect a .02 μfd ceramic capacitor between lugs 1 (NS) and 4 (S-2) of tube socket V2.
- Connect a .02 μfd ceramic capacitor between lugs 1 (S-3) and (S-2) of tube socket V2.
- Connect a 200 $\mu\mu\text{f}$ mica capacitor from lug 2 of tube socket V1 (S-4) to solder lug AB (S-1).
- Connect a .02 μfd ceramic capacitor between lug 2 (S-1) and lug 3 (NS) of terminal strip M.

NOTE: In the following steps, bend the leads of the 10 μh RF choke (#45-60) to reach their proper connecting points, then cut off any excess lead lengths. Bend the leads very carefully so as not to damage the coil form. Also, do not allow the choke to extend over the rear edge of the chassis.

- At one end of the coil, connect lead 1 to lug 3 (S-3) and lead 2 to lug 5 (S-3) of terminal strip M.
- At the other end of the coil, connect lead 4 to lug 4 (S-2) and lead 3 to lug 1 (S-2) of tube socket V1.

This completes the wiring. Carefully check to see that no wiring errors were made and that all connections are soldered. Shake out any wire clippings and solder splashes.

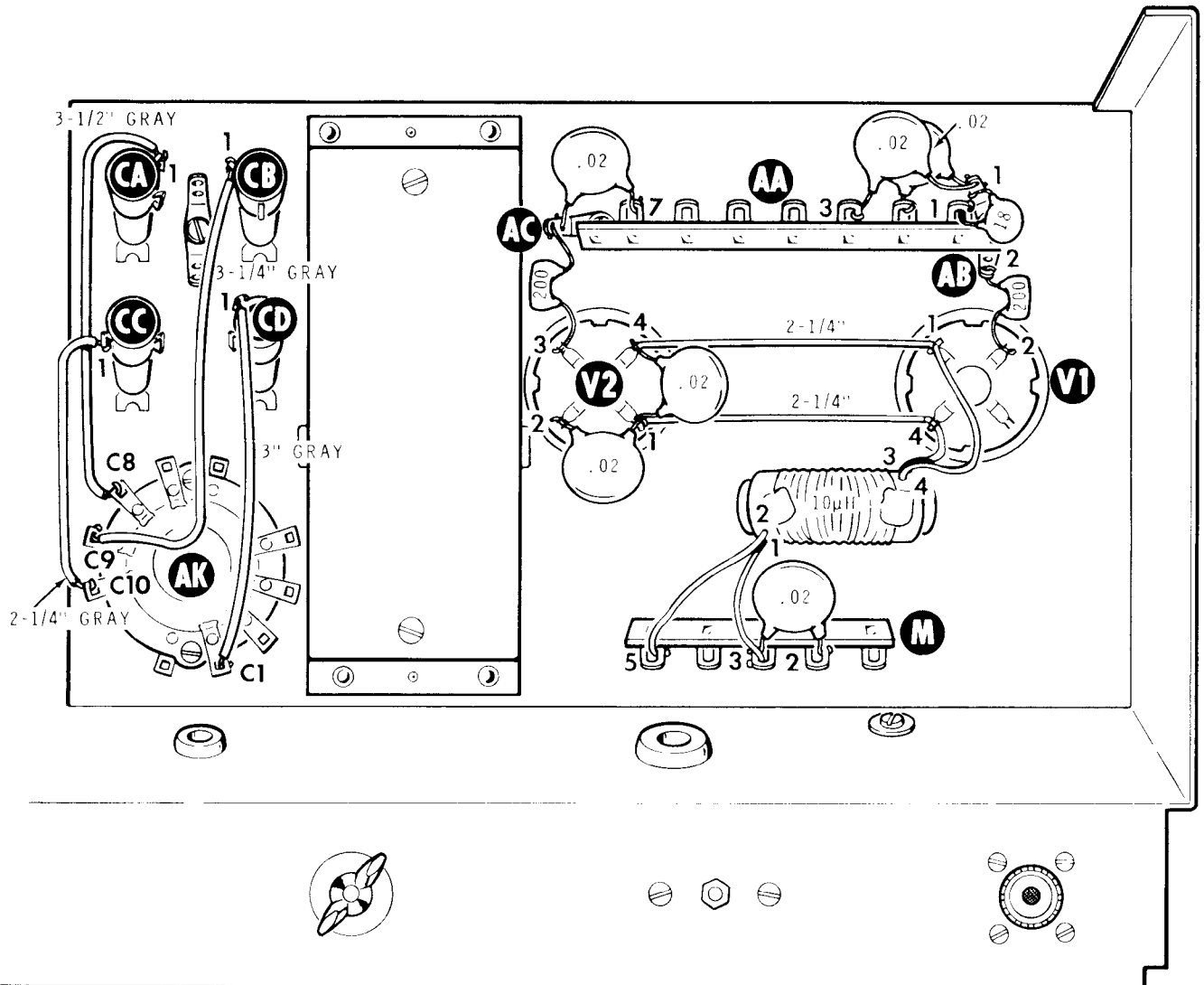

PICTORIAL 11

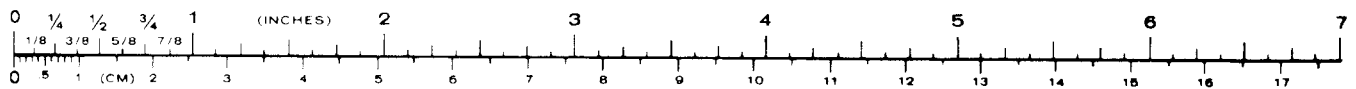

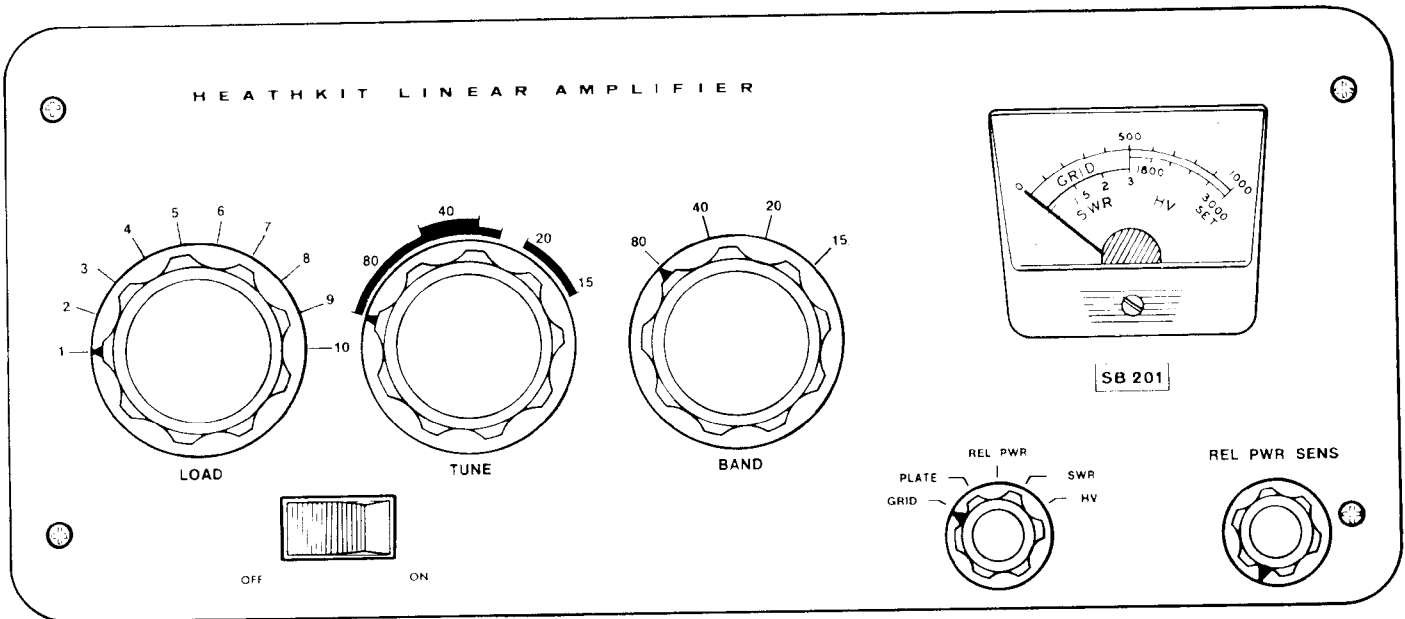

PICTORIAL 12

Refer to Pictorial 12 for the following steps.

- (✓) Rotate all switch and control shafts fully counterclockwise, except the TUNE and LOAD capacitors which should be rotated until the plates are fully meshed (closed).
- (✓) Refer to Detail 12A and install 8-32 × 1/4" setscrews in each of the five knobs.
- (✓) Install small knobs at the Meter and REL PWR SENS locations. Position the pointers as shown.
- (✓) Install the large knobs at the LOAD, TUNE, and BAND locations, using 8-32 × 1/4" setscrews. Position the pointers as shown.
- (✓) Remove the protective backing from the nameplate and press it firmly in place directly under the meter. The nameplate should cover the printed outline at the nameplate location.

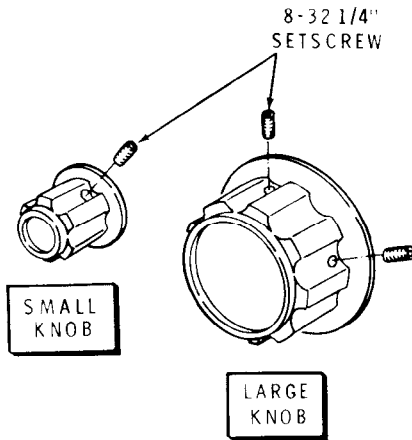

Detail 12A

- (✓) Refer to Pictorial 13 and prepare a 4 foot long cable to reach between the Linear Amplifier and your exciter. Use the large shielded cable (RG-58A/U) and a phono plug connected at one end. It will be necessary to install the proper type connector to the other end of this cable to match the antenna connector of your exciter.

NOTE: If it is necessary to install a coaxial connector to any of the cables, refer to Pictorial 14, for proper installation.

PREPARE EACH END AS SHOWN.

TAKING CARE NOT TO CUT THE OUTER SHIELD OF VERY THIN WIRES, REMOVE THE OUTER INSULATION.

SEE DIMENSION ABOVE

PUSH THE SHIELD BACK AS FAR AS IT WILL GO AND REMOVE THE SPECIFIED LENGTH OF INSULATION FROM THE INNER LEAD.

SOLDER

PLACE THE PHONO PLUG ON THE CABLE FIRMLY AGAINST THE INNER INSULATION. SOLDER THE INNER LEAD.

SOLDER

PUSH THE SHIELD UP ON THE BASE OF THE PLUG AND SOLDER, THEN TRIM THE INNER INSULATION AND SOLDER, THEN TRIM THE INNER LEAD FROM THE TIP.

PICTORIAL 13

INSERT

COAXIAL PLUG

1/4"

3/4"

SOLDER

PICTORIAL 14

PREPARE EACH END AS SHOWN.

SHIELD

1"

5/8"

1/4"

1/2"

TAKING CARE NOT TO CUT THE OUTER SHIELD OF VERY THIN WIRES, REMOVE THE OUTER INSULATION.

SEE DIMENSION ABOVE

TWIST THE SHIELD WIRES INTO ONE STRAND. REMOVE THE INNER INSULATION. THEN APPLY A SMALL AMOUNT OF SOLDER TO THE END OF THE INNER LEAD AND THE SHIELD.

SOLDER

INSERT THE INNER LEAD THROUGH THE PLUG AND WRAP THE SHIELD AROUND THE PLUG.

APPLY HEAT TO THE TIP OF THE PIN ONLY LONG ENOUGH FOR THE SOLDER TO BE DRAWN UP INTO THE PIN BY CAPILLARY ACTION.

SOLDER THE SHIELD ONTO THE PLUG.

CUT OFF EXCESS WIRE FROM THE TIP OF THE PIN.

SOLDER

PICTORIAL 15

() Refer to Pictorial 15 and prepare two 4 foot long cables to reach between the Linear Amplifier and the exciter. Use the small shielded cable with a phono plug connected at one end. It will be necessary to install the proper type of connector to the other ends of these cables to connect to the exciter. One of these cables connects between the ANT RELAY jack of the Linear Amplifier and the LINEAR RELAY jack of the exciter. The other cable connects between the ALC jack of the Linear Amplifier and the ALC input of the exciter, if your exciter has provisions for ALC input from a Linear Amplifier.



INITIAL TEST

The input coils are factory adjusted and do not require any further alignment.

RESISTANCE CHECK

- (✓) The resistance between either anode clip and the chassis should measure approximately 180 k Ω after the meter stabilizes.
- () The resistance between lug 3 of either tube socket V1 or V2 and the chassis should measure between 5000 Ω and 15,000 Ω .

If you encounter any difficulty in obtaining either of these resistance readings, refer to the In Case Of Difficulty section of the manual on Page 50.

CAUTION: LETHAL VOLTAGES ARE PRESENT IN THIS UNIT. USE EXTREME CARE WHEN MAKING ANY TESTS.

If at any time during the testing and operation the Linear Amplifier does not perform as described, unplug the Linear Amplifier line cord and refer to the In Case Of Difficulty section of the manual.

- () Rotate all knobs to their fully counterclockwise positions, except the TUNE knob which should be at its 9 o'clock position. Place the OFF-ON switch in the OFF position.

- (✓) Plug the line cord plug into the power source for which the unit is wired, either 120 volts or 240 volts AC.

- (✓) Push the OFF-ON switch to ON.

- (✓) Check to see that the tube filaments and meter pilot lamp light, and that the fan operates.

- (✓) Rotate the meter switch through all of its positions. There should not be a meter indication in any position, except for HV which should read approximately 2400 volts.

- (✓) Push the OFF-ON switch to OFF and unplug the line cord.

- (✓) To insure the discharge of the filter capacitors and reduce the shock hazard, short the anode clip of one of the tubes to the chassis, using a screwdriver with an insulated handle.

FINAL ASSEMBLY

Refer to Pictorial 16 for the following steps.

- () Install the top plate, using #6 \times 3/8" sheet metal screws.
- () Remove the protective backing from a DANGER label and press it firmly in place on the top plate, as shown.
- (✓) Slide the chassis into the cabinet.

- (✓) Install rubber feet at the rear of the cabinet, using 6-32 \times 3/4" screws and 3/8" flat steel washer.

- (✓) Install rubber feet and tapered spacers at the front of the cabinet, using 6-32 \times 1-1/2" screws and 3/8" flat steel washers. NOTE: If you wish to have the Linear Amplifier set flat, extra 6-32 \times 3/4" screws are supplied for mounting feet at the front only.

INSTALLATION

LOCATION

Although the Linear Amplifier has a built-in fan for cooling purposes, avoid excessively warm locations such as those near radiators and heating vents. The unit should be placed in a location that provides adequate space around it, permitting free air circulation through the cabinet openings.

POWER SOURCE

The Linear Amplifier is designed to operate from either a 120 volt or 240 volt AC, 60 Hertz power source, depending on the jumper installation on terminal strip S. The AC power outlet used should be properly fused and fed with not smaller than #14 wire.

The plug on the power cord for this kit is for standard 120 VAC outlets. For 240 VAC operation in the U.S.A. cut off this plug and replace it with a permanent plug that matches your 240 VAC receptacle. Be sure your power connection conforms with section 210-21 (b) of the National Electric Code, which reads in part:

“Receptacles connected to circuits having different voltages, frequencies or types of current (AC or DC) on the same premises shall be of such design that attachment plugs used on such circuits are not interchangeable.”

When you install a new plug, make sure it is connected according to your local electrical code. Keep in mind that the green line cord wire is connected to the amplifier chassis.

EXCITER

The Linear Amplifier can be driven by most commercial or home-built exciters with a power output of approximately 100 watts. The Heathkit SB-400 or SB-401 Transmitter or the SB-100, SB-101, SB-102, or SB-104 Transceiver is ideal for use with this Linear Amplifier.

Exciters in the 40 to 60 watt output class will not drive the Linear Amplifier to a full kilowatt, however, the

Linear Amplifier will operate quite efficiently at lower power levels.

ANTENNA

The pi-network output is designed to work into a 50 to 75 Ω transmission line. Most commercial and home-built antennas are designed to be fed with 50 or 72 Ω coax. RG-8/U or RG-11/U coaxial cable is recommended for the transmission line, and every effort should be made to get the SWR of the antenna down to less than 2 to 1.

SWR MEASUREMENTS

- (✓) Connect the amplifier to the exciter and the antenna. **Do not turn the Linear Amplifier ON**, thus permitting the exciter to feed through the Linear Amplifier to the antenna.
- (✓) Place the Linear Amplifier Meter switch in the REL PWR position.
- (✓) Load the exciter to full output. The meter of the Linear Amplifier may be used for this purpose, as it will function in both the REL PWR and SWR positions without the Linear Amplifier being turned ON.
- (✓) Adjust the REL PWR SENS control of the Linear Amplifier for a SET (full-scale) indication on the meter.
- (✓) Turn the meter switch to SWR and read the standing wave ratio directly from the meter (1 to 3 scale).

NOTE: SWR checks can also be made with the Linear Amplifier operating at full power (1000 watts); however, due to the nonlinear characteristics of crystal diodes in the SWR circuit, the most accurate SWR readings are obtained at low power (70 to 100 watts) levels using only the exciter. If the exciter alone will not give full scale relative power readings, the Linear Amplifier may be used. However, limit the drive from the exciter to no more than necessary.



EQUIPMENT INTERCONNECTIONS

Interconnections between this Amplifier and other Heath equipment are shown in Pictorials 17 through 20 (Illustration Booklet, Pages 8 and 9). Other makes of equipment should be connected to the Linear Amplifier in a similar manner.

Observe in Pictorial 20 that an external antenna relay with extra contacts is necessary to obtain proper antenna switching when you connect the Linear Amplifier to transmitters that do not have a built-in antenna relay.

NOTE: The ANT RELAY jack of the Linear Amplifier must be grounded by the exciter to place the Linear Amplifier into operation. (See the Circuit Description.) This grounding is accomplished by the VOX relay or a transmit-receive switch in the exciter.

OPERATION

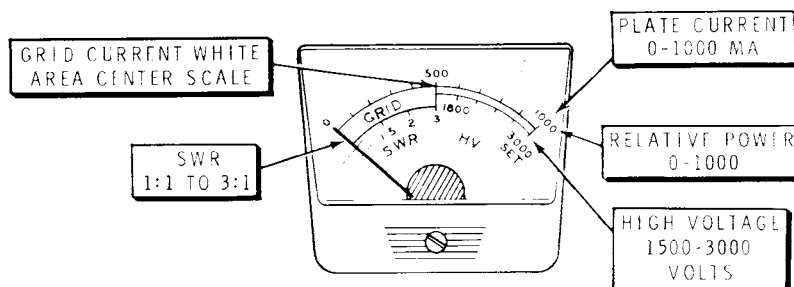

PICTORIAL 21

METER READINGS

Refer to Pictorial 21 and study the meter scale. Note how it indicates for the various positions of the Meter switch.

Interpret the meter scales as follows:

METER SWITCH POSITION	MEASURES	SCALE READING
GRID	Grid current	GRID (White area represents 0-100 mA)
PLATE	Plate current	0-1000 mA
REL PWR	Relative power output	0-1000
SWR	Standing wave ratio	1:1 to 3:1
HV	High voltage	1500-3000



OPERATING PROCEDURE

Make sure the Linear Amplifier is connected to your exciter properly.

() Set all switches and controls as follows:

SWITCH OR CONTROL	SWITCH OR CONTROL POSITION	COMMENTS
OFF-ON	OFF	Linear amplifier line cord connected to proper power source.
LOAD	<u>80 meter segment</u>	Or desired band segment. Note desired position for antenna used and preset next time. position for antenna used next time.
BAND	80 meters	Or desired band.
TUNE	80 meter segment	Or desired band segment.
METER	REL PWR	
REL PWR SENS	FULLY CLOCKWISE	Adjust to keep meter pointer on scale.

- () Adjust the exciter for full CW output at the desired frequency. NOTE: With the Linear Amplifier turned OFF, the exciter output is fed through the Linear Amplifier to the RF OUTPUT jack. Also, the REL PWR and SWR functions of the Meter may be used to aid in tuning the exciter.
- () Reduce the drive level of the exciter to a minimum.
- () Place the Meter switch of the Linear Amplifier in the PLATE position and push the OFF-ON switch to ON. With no driver output from the exciter, the Linear Amplifier meter should show idling plate current of approximately 90mA.
- () Advance the drive level of the exciter for a 200 mA plate current indication on the meter of the Linear Amplifier.
- () Quickly switch the Linear Amplifier Meter switch to REL PWR. If necessary, reduce the REL PWR SENS control setting to keep the meter pointer within the scale.
- () Adjust the TUNE and LOAD controls for a maximum REL PWR meter indication.
- () Increase the drive level from the exciter to full output.
- () Again, adjust the TUNE and LOAD controls for a maximum REL PWR meter indication.
- () Check the GRID and PLATE meter readings. If the grid reading is greater than midscale, reduce the drive level of the exciter to bring grid current within the GRID range of the meter. If the plate current reading is higher than 500 mA, reduce loading by turning the LOAD control counterclockwise.



This procedure of tuning the Linear Amplifier should take only a few seconds after you go through it a few times. Note the LOAD control position so it can be preset next time a particular band is used.

The Linear Amplifier is now loaded for operation at maximum input power. If an oscilloscope is being used for monitoring, a display similar to that shown in Pictorial 22 should be obtained.

Turn the exciter to standby to remove drive from the Linear Amplifier.

The Linear Amplifier is now ready for SSB or CW transmission. An example of a proper oscilloscope pattern is shown in Pictorial 23. Note that there are sharp distinct peaks. The number of patterns or "christmas trees" will depend on the individual voice and the scope sweep speed. Set the scope for about a 30 Hertz sweep.

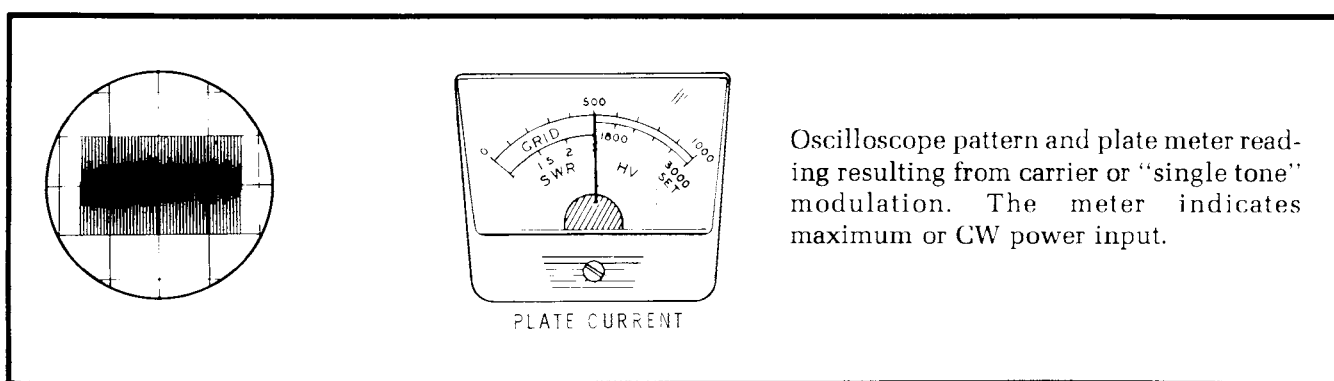

Oscilloscope pattern and plate meter reading resulting from carrier or "single tone" modulation. The meter indicates maximum or CW power input.

PICTORIAL 22

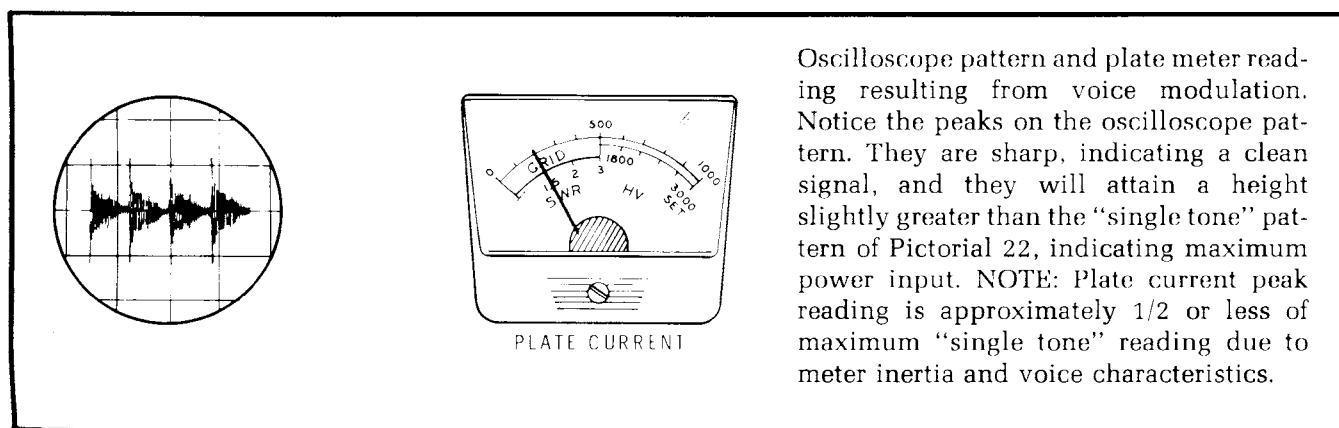

Oscilloscope pattern and plate meter reading resulting from voice modulation. Notice the peaks on the oscilloscope pattern. They are sharp, indicating a clean signal, and they will attain a height slightly greater than the "single tone" pattern of Pictorial 22, indicating maximum power input. NOTE: Plate current peak reading is approximately 1/2 or less of maximum "single tone" reading due to meter inertia and voice characteristics.

PICTORIAL 23

Note that the meter reading on voice peaks will not be high; however, the height of the oscilloscope pattern is slightly greater than that shown in Pictorial 22. This increase in peak power is due to dynamic characteristics of the power supply and allows the Linear Amplifier to develop approximately 20% greater peak envelope power for a given level of CW input. The meter will indicate only one-half or less of the single

tone level, depending on the individual's voice, before "flat topping" occurs.

Pictorial 24 shows the same voice pattern but with extreme "flat topping." The oscilloscope shows that no more useful power is being developed. The meter reads higher, but only distortion is developed.

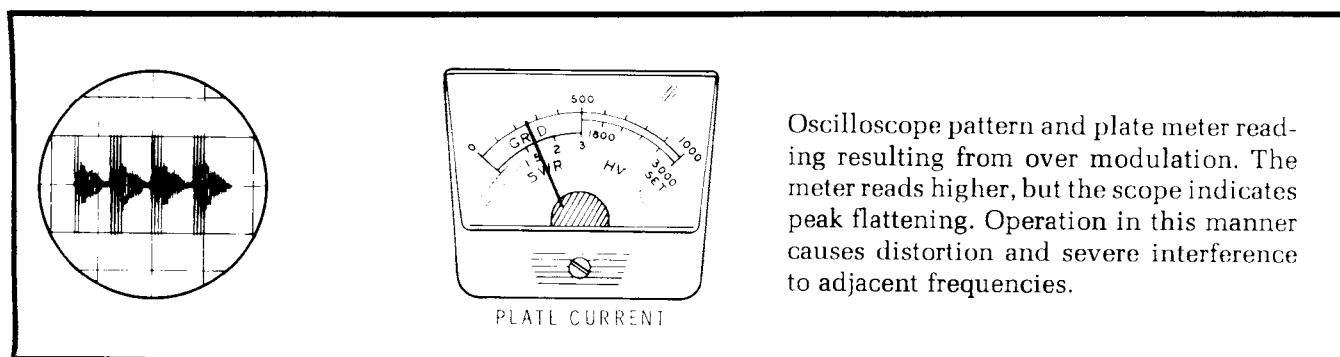

Oscilloscope pattern and plate meter reading resulting from over modulation. The meter reads higher, but the scope indicates peak flattening. Operation in this manner causes distortion and severe interference to adjacent frequencies.

PICTORIAL 24

IN CASE OF DIFFICULTY

1. Recheck the wiring. Trace each lead in colored pencil on the Pictorial as it is checked. It is frequently helpful to have a friend check your work. Someone who is not familiar with the unit may notice something consistently overlooked by the constructor.
2. It is interesting to note that about 90% of the kits that are returned for repair, do not function properly due to poor connections and soldering. Therefore, many troubles can be eliminated by reheating all connections to make sure that they are soldered as described in the Proper Soldering Techniques section of this manual.
3. Make sure that the tubes light up properly.
4. Check the tubes with a tube tester or by substitution of tubes of the same types and known to be good.
5. Check the values of the parts. Be sure that the proper part has been wired into the circuit, as shown in the Pictorial Diagrams and as called out in the wiring instructions.
6. Check for bits of solder, wire ends or other foreign matter which may be lodged in the wiring.
7. If, after careful checks, the trouble is still not located and a voltmeter is available, check voltage readings against those shown on the Schematic Diagram. NOTE: All voltage readings were taken with an 11 megohm input vacuum tube voltmeter. Voltages may vary as much as 10% .
8. A review of the Circuit Description will prove helpful in indicating where to look for trouble.

NOTE: In an extreme case where you are unable to resolve a difficulty, refer to the "Customer Service" information inside the rear cover of the Manual. Your Warranty is located inside the front cover.



SPECIFICATIONS

Band Coverage	80, 40, 20, and 15 meters.
Maximum Power Input	SSB: 1200 watts P.E.P. CW: 1000 watts.
Driving Power Required	100 watts.
Duty Cycle	SSB: continuous voice modulation. CW: 50% (keydown time not to exceed 5 minutes).
Third Order Distortion	-30 db or better at 1000 watts P.E.P.
Output Impedance	50 to 75 Ω unbalanced; variable pi-output circuit. SWR not to exceed 2:1.
Input Impedance	52 Ω unbalanced; broad-band pretuned input circuit requires no tuning.
Meter Functions	0-100 mA grid current (white area). 0-1000 mA plate current. 0-1000 relative power. 1:1 to 3:1 SWR. 1500-3000 volts high voltage.
Front Panel Controls	LOAD: 1 to 10 TUNE: 80, 40, 20, and 15 meters. BAND: 80, 40, 20, and 15 meters. RELative Power SENSitivity. Meter Switch: GRID, PLATE, REL PWR, SWR, and HV. Power Switch: OFF, ON.
Tube Complement	Two 572-B (or two T-160-L) in parallel.
Power Requirements	120 volts AC at 16 amperes (maximum). 240 volts AC at 8 amperes (maximum).
Cabinet Size	14-7/8" wide \times 6-5/8" high \times 13-3/8" deep. (37.8 \times 16.8 \times 34.0 cm)
Net Weight	35 lbs. (15.9 kg)

The Heath Company reserves the right to discontinue products and to change specifications at any time without incurring any obligation to incorporate new features in products previously sold.



CIRCUIT DESCRIPTION

POWER SUPPLY

The power supply uses a power transformer which has dual-primary and triple-secondary windings. The primary winding may be connected for either 120 or 240 volt AC operation. The blower fan is connected across one-half of the primary winding. The transformer is protected against overload by reset type circuit breakers CB1 and CB2.

One secondary winding of the power transformer supplies 6.3 volts AC for the tube filaments and the pilot lamp in the meter. Another secondary winding is used with silicon diodes D1 through D16 and electrolytic capacitors C4 through C9 in a full-wave voltage-doubler circuit to provide plate voltage for the tubes. Resistors R5 through R10 insure that the voltage across each of the electrolytic capacitors is equalized; these resistors also serve as a bleeder network.

Resistor R11 at the bottom of the bleeder network provides an ALC threshold voltage of approximately 10 volts DC. Resistor R12 provides a means of measuring plate current independently, without also measuring bleeder current.

The third secondary winding, with resistors R1 and R2, capacitor C3, and silicon diode D17 forms a half-wave rectifier circuit. This circuit provides antenna relay control voltage and cutoff bias voltage for the grids of the amplifier tubes.

INPUT CIRCUIT

Tubes V1 and V2 are connected in parallel in a cathode-driven (grounded grid), class B configuration. Driving power for each band is coupled through a broad-band network, consisting of a coil and associated capacitors, and through capacitor C16 to the cathodes of tubes V1 and V2. Coils L1 through L4 with their associated capacitors are used to make up these impedance-matching networks, which reduce distortion and increase efficiency.

The correct input network, as well as the correct output circuit coil tap, for each band is selected with the Band switch. (The coils in the input networks are factory aligned and require no further adjustment.)

To keep the capacitance of the transformer filament winding from shunting the RF driving power to ground, the filament winding is isolated from the cathode circuit by a bifilar-wound filament choke. Also, this choke provides a cathode current path to ground.

OUTPUT CIRCUIT

High voltage is applied to the plates of tubes V1 and V2 through RF choke RFC1 and parasitic chokes PC1 and PC2. Tuning capacitor C25 is connected on the input side of final coils L5 and L6. C26 is switched in parallel with the Tuning capacitor on the 80 meter band.

Loading capacitor C28 is on the output side of final coils L5 and L6. Capacitor C27 is switched in parallel with the Loading capacitor on the 80 meter band. Output power is applied through antenna change-over relay RL1 and through the SWR (standing wave ratio) bridge circuit to the RF Output connector. The SWR bridge consists of L7, L8, L9, capacitors C20 and C23, resistors R19 and R20, and crystal diodes CR1 and CR2.

ANTENNA CHANGE-OVER AND CUTOFF BIAS CIRCUITS

Antenna change-over relay RL1 is controlled by a VOX (voice operated transmitter) relay in the exciter used with the Linear Amplifier. The relay in the exciter is connected to the Antenna Relay jack of the Linear Amplifier. When transmitting, the VOX relay grounds the Antenna Relay; when receiving, the Antenna Relay is ungrounded.

While receiving, cut-off bias voltage from the power supply bias circuit is applied through the coil of relay RL1, and through resistor R15 and choke RFC2, to the grids of tubes V1 and V2. The Antenna Relay jack is ungrounded and no current will flow through the coil of relay RL1, which allows the relay to remain open. Thus it connects the RF Output jack (antenna) to the RF Input jack of the Linear Amplifier.



When transmitting, the Antenna Relay jack is grounded by the VOX relay of the exciter. This allows current to flow through the coil of relay RL1 and actuate the relay. When actuated, relay RL1 connects the RF Output jack (antenna) to the output circuit of the Linear Amplifier. Grounding the Antenna Relay jack also grounds the grids of tubes V1 and V2 through RFC2, and resistors R15 and R16. This removes all but -2 volts from the grids of the tubes. This -2 volts is operating bias, which limits resting plate current to approximately 90 milliamperes.

When operating with the Linear Amplifier turned OFF, there is no bias voltage to operate relay RL1 and the RF Input jack remains connected to the antenna, through RF Output jack. This permits low power operation directly from the exciter into the antenna without changing any cables. Because silicon rectifiers and instant-heating-filament tubes are used in the Linear Amplifier, you can go to high power operation as soon as the Linear Amplifier is turned ON.

METERING CIRCUITS

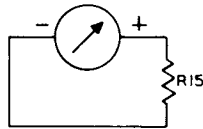

Figure 1-1

GRID— Figure 1-1

In the Grid position of the meter switch, the meter is connected to measure the voltage across grid resistor R15. The voltage across this resistor is directly proportional to the grid current which flows through it; therefore, the meter will indicate grid current. Since grid current in tubes V1 and V2 should not exceed 100 mA, only half (white area) of the 0-200 mA meter scale is used for this measurement.

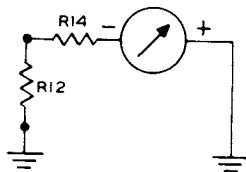

Figure 1-2

PLATE — Figure 1-2

Plate current is read on the top scale of the meter. This scale is divided into 20 mA divisions from 0 to 1000 mA. Plate current readings are obtained by measuring the voltage across resistor R12, through series resistor R14.

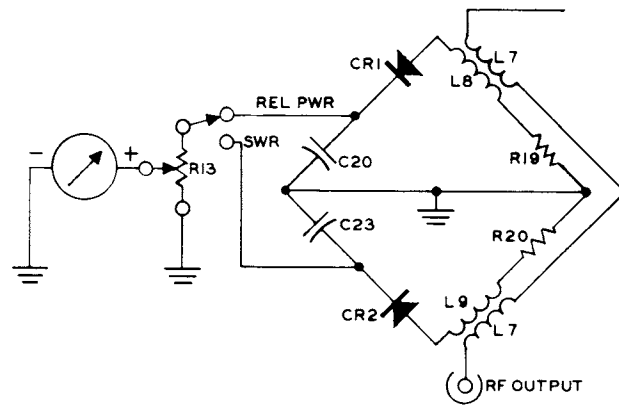

Figure 1-3

REL PWR And SWR — Figure 1-3

Relative Power and Standing Wave Ratio are measured with a bridge circuit, consisting of coils L7, L8, and L9, diodes CR1 and CR2, resistors R19 and R20, and capacitors C20 and C23. Relative Power Sensitivity control R13 sets the sensitivity of the meter. The REL POWER position is used when adjusting the TUNE and LOAD controls for maximum output of the Linear Amplifier; this meter function is also used to establish a "set" meter level for making SWR measurements.

Because coil L7 of the bridge circuit is connected in series between the RF Output jacks when the Linear Amplifier is turned OFF, the meter can be used to measure REL PWR and SWR when operating the exciter alone. This method of checking SWR is recommended for accurately determining antenna performance.

In the bridge circuit, RF current is inductively and capacitively coupled from L7, to L8 and L9. The RF currents in L8 and L9 are rectified by diodes CR1 and CR2, and then filtered by capacitors C20 and C23.

For REL PWR measurements, the rectified RF voltage from L8 is applied to the meter. For SWR (reflected power) measurements, the rectified RF voltage from L9 is applied to the meter.

HV — Figure 1-4

High Voltage is measured with a voltage divider network consisting of resistors R3 and R4. The voltage across resistor R4 is applied to the meter. High voltage is read on the lower right-hand meter scale (1500 to 3000).

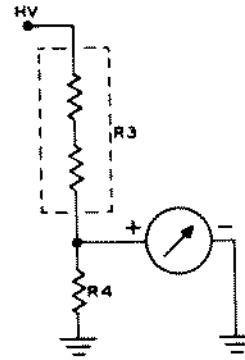
**Figure 1-4**

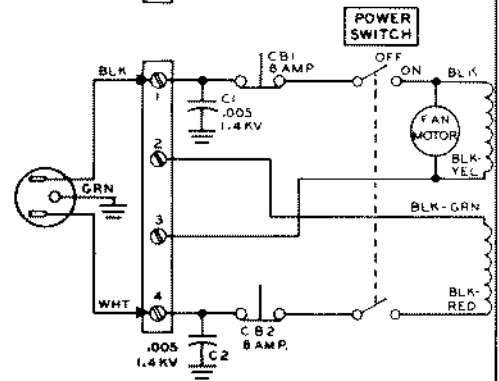
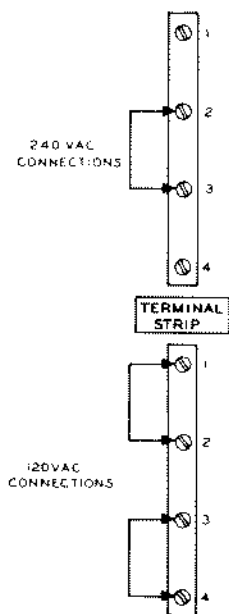

**SCHEMATIC OF THE
HEATHKIT®
LINEAR AMPLIFIER
MODEL SB-201**

NOTES:
 ALL RESISTORS ARE 1/2 WATT UNLESS MARKED OTHERWISE.
 ALL RESISTOR VALUES ARE IN OHMS (K=1000, MEG=1,000,000).
 ALL CAPACITOR VALUES ARE IN μFD UNLESS MARKED OTHERWISE.
 ALL VOLTAGE MEASUREMENTS ARE TO BE TAKEN WITH NO SIGNAL INPUT.
 ALL VOLTAGE MEASUREMENTS ARE POSITIVE UNLESS MARKED OTHERWISE.
 ALL VOLTAGE MEASUREMENTS ARE TO BE TAKEN FROM POINT INDICATED TO CHASSIS GROUND.
 EXCEPT AS NOTED, ALL MEASUREMENTS ARE TO BE TAKEN FROM POWER TRANSFORMER WINDINGS.
 VOLTAGE READINGS ARE TO BE TAKEN WITH AN 11 MEGOHM INPUT VTVM.
 VOLTAGE MEASUREMENTS ARE TO BE TAKEN WITH THE METER SET TO 300.
 ALL SWITCHES ARE TO BE TAKEN FROM THE REAR (UNLESS MARKED OTHERWISE) AT
 FULL COUNTERCLOCKWISE ROTATION.
 ARROW INDICATES COUNTERCLOCKWISE ROTATION OF KNOB.

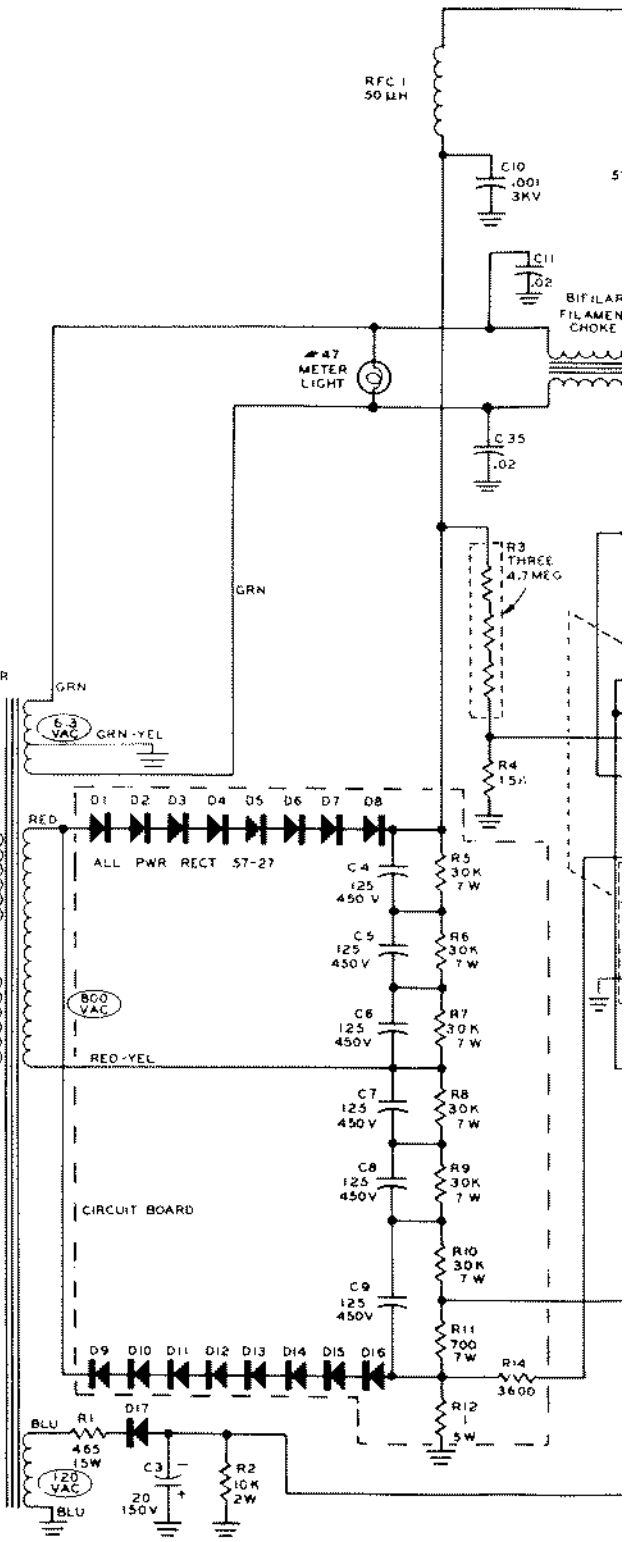

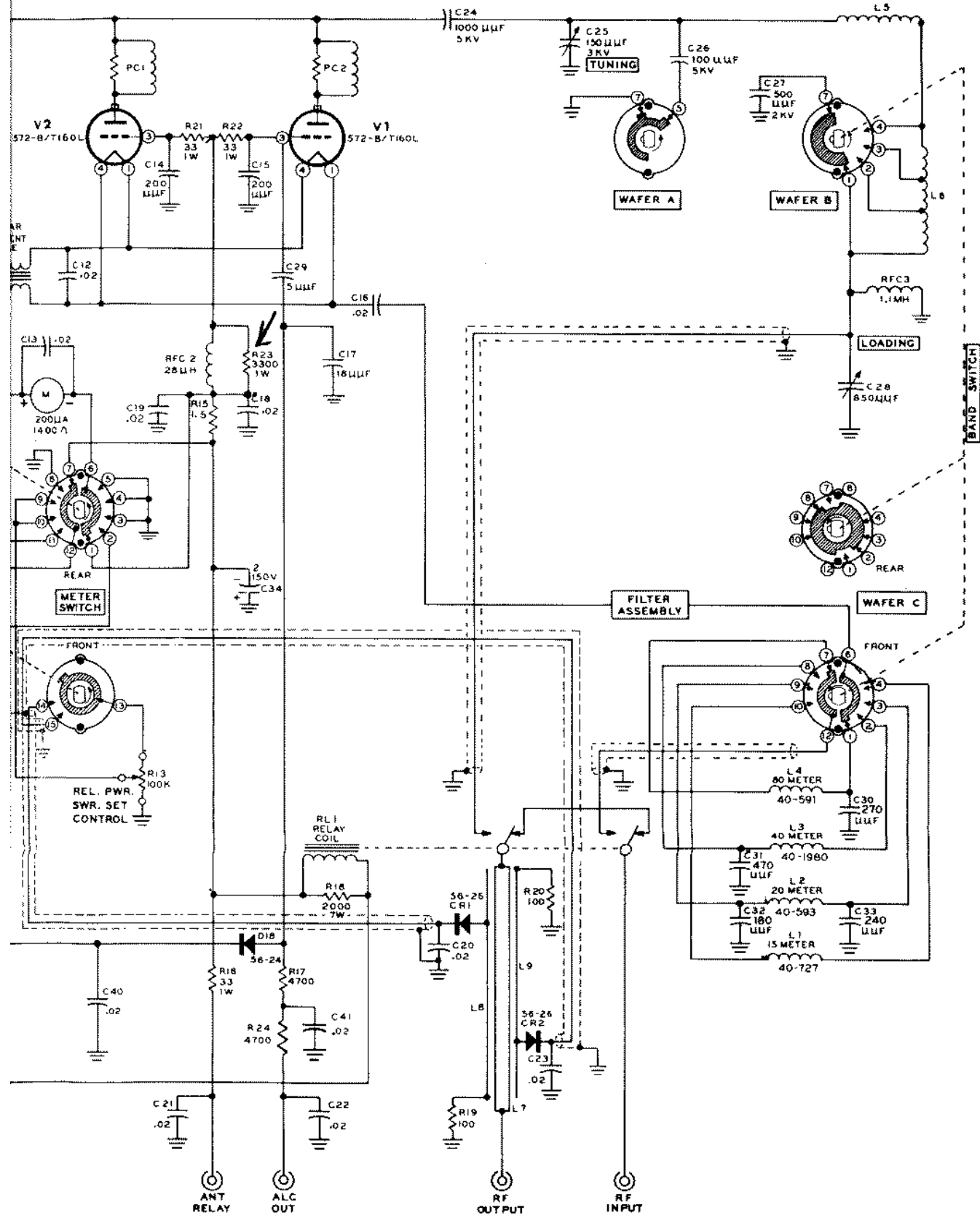



HEATH COMPANY • BENTON HARBOR, MICHIGAN 49022
TLX 72-9421

IMPORTANT NOTICE

Use the following information and the bracket supplied with this Notice as you mount the circuit board to the chassis on Page 17 in your Manual.

NOTE: The purpose of the corner bracket is to strengthen the corner of the chassis. Install this bracket to the underside of the chassis at the same time you mount the circuit board.

Thank you,

HEATH COMPANY

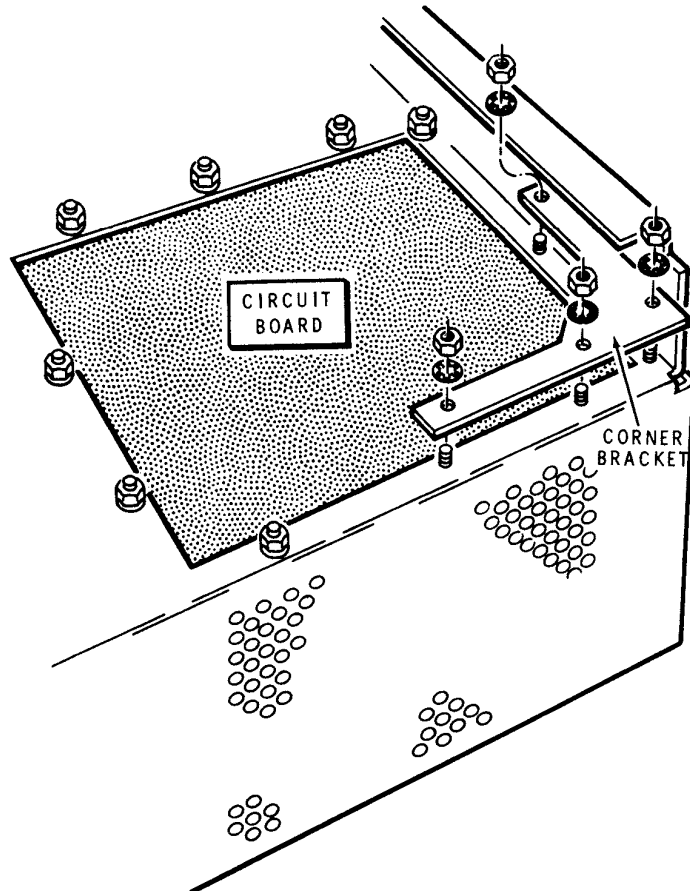

SB-201/595-2207-02
591-3237

