

# BLOCK

AGC

\* OPTIONAL (AVAILABLE FROM CRYSTAL FILTER SUPPLIER)

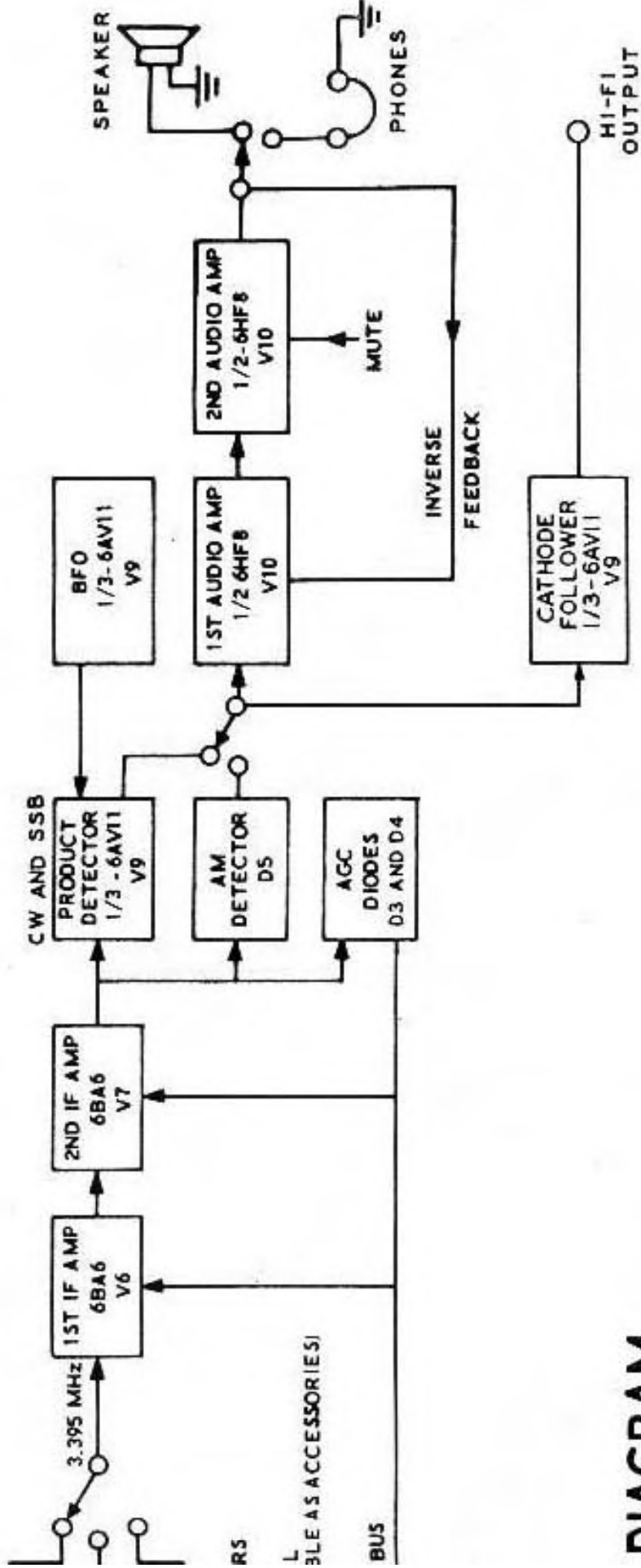

**DIAGRAM**

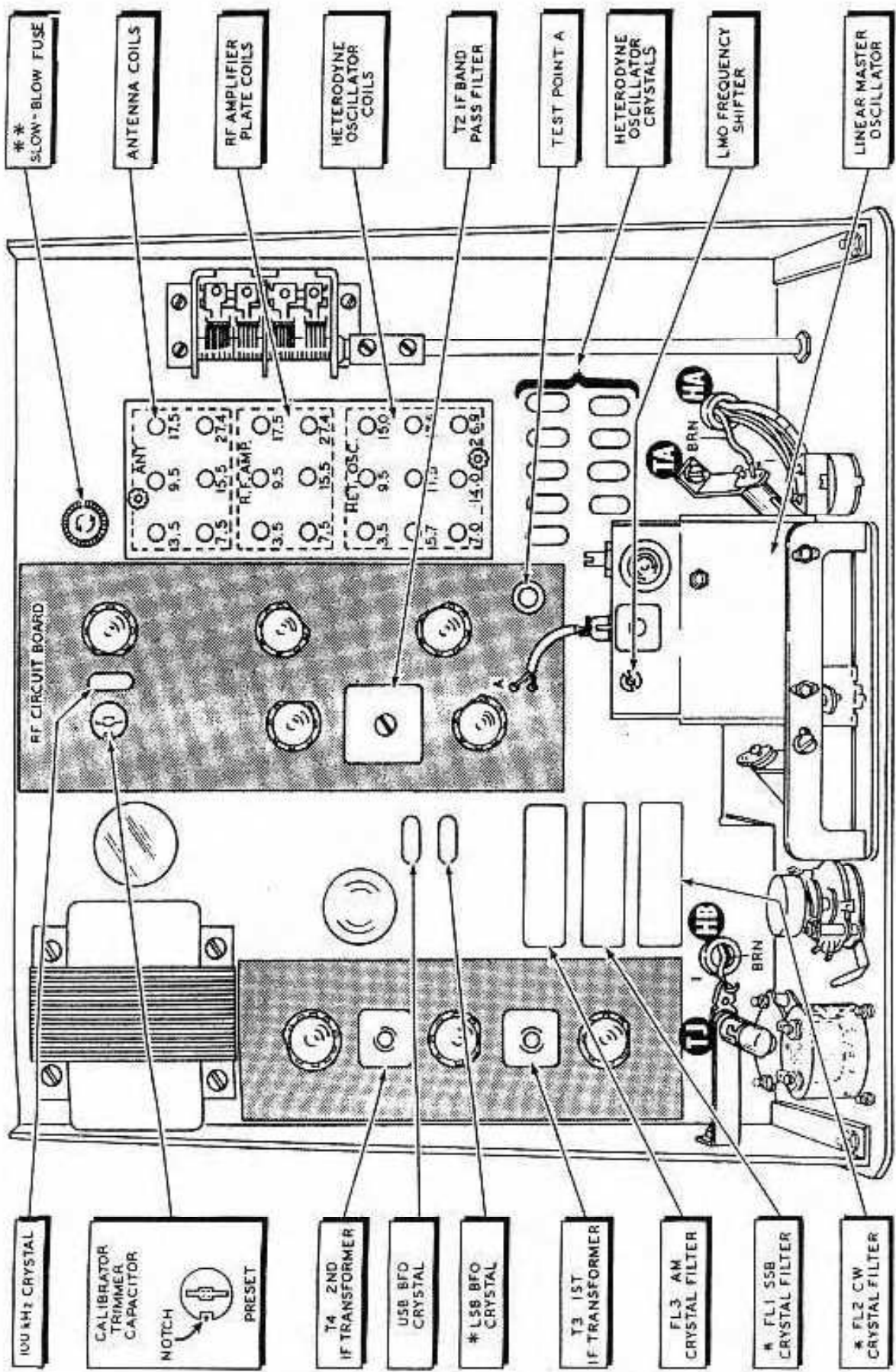

\*\* 120 VAC: 2 AMPERE  
240 VAC: 1 AMPERE

\* ACCESSORY

FIGURE 1-2

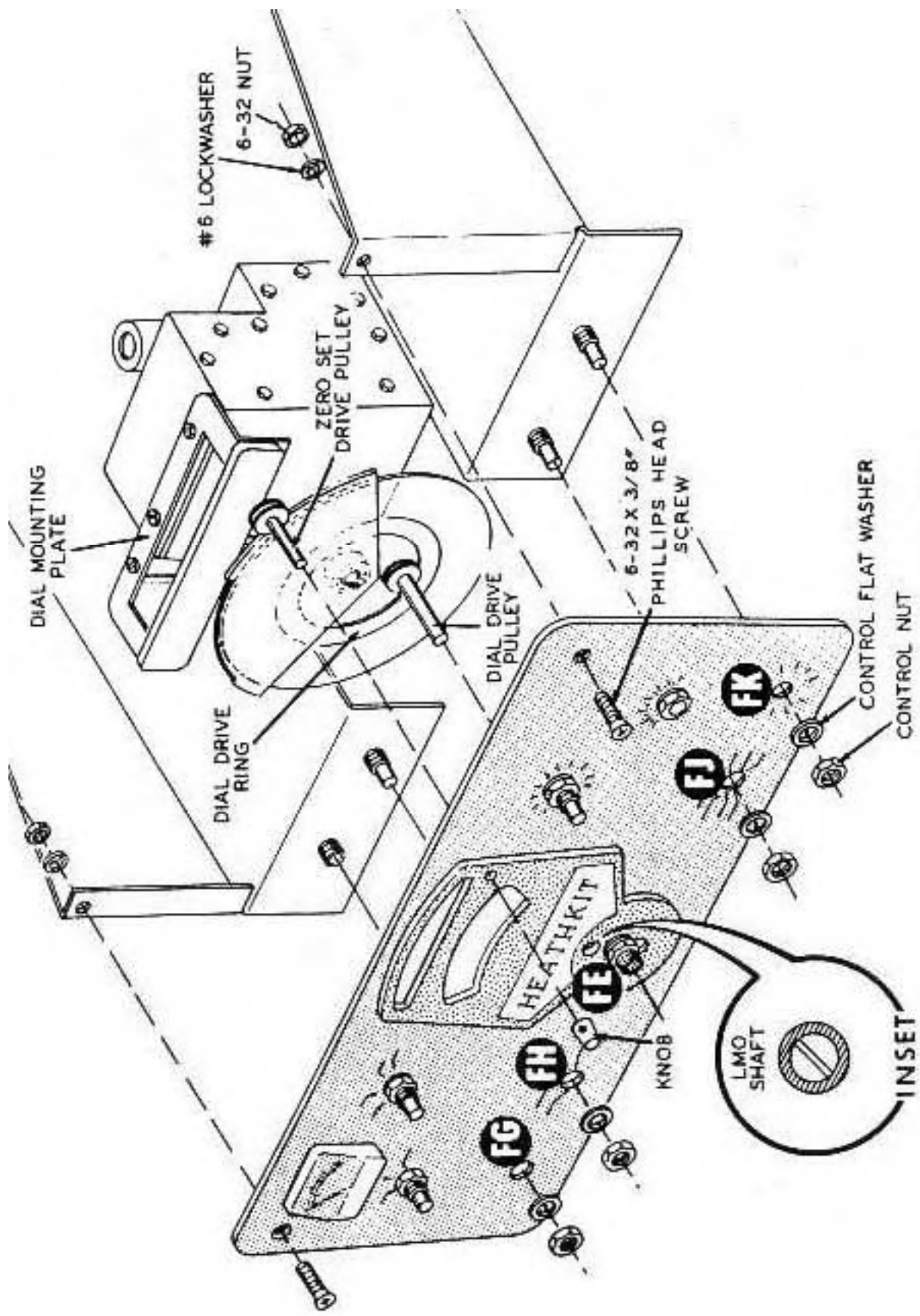

**Detail 5-4B**

# CIRCUIT BOARD X-RAY VIEWS (VIEWED FROM FOIL SIDE)

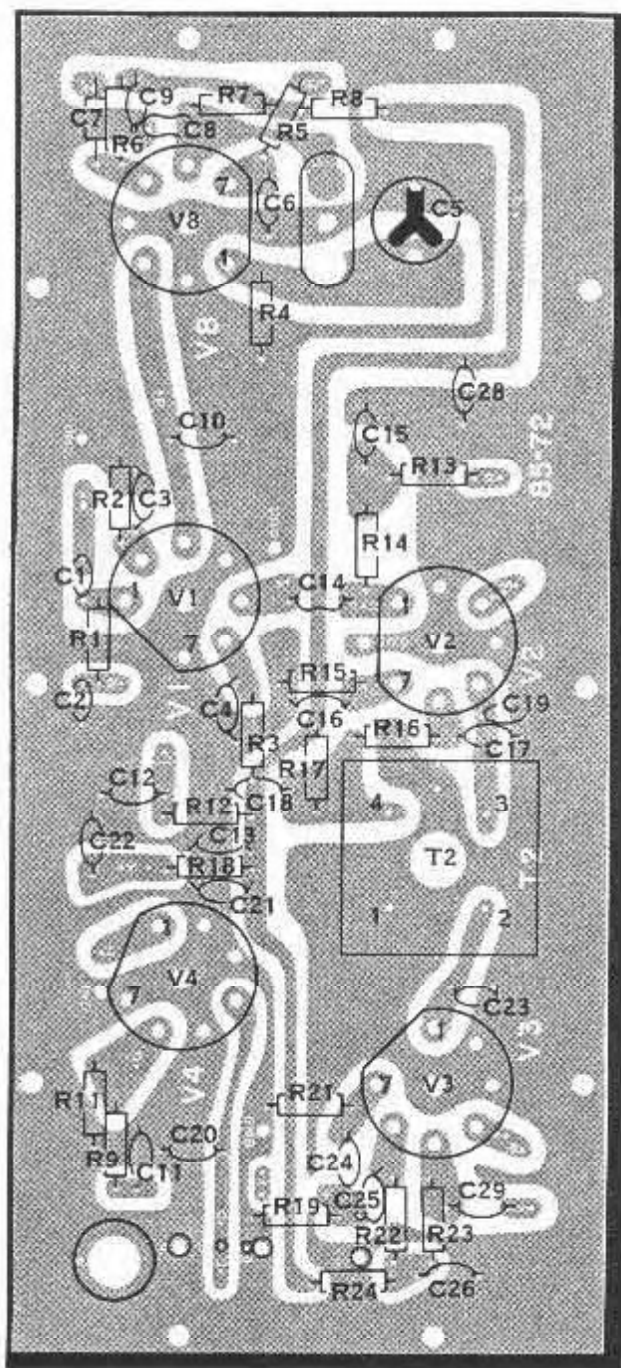

RF CIRCUIT BOARD

Figure 7-1

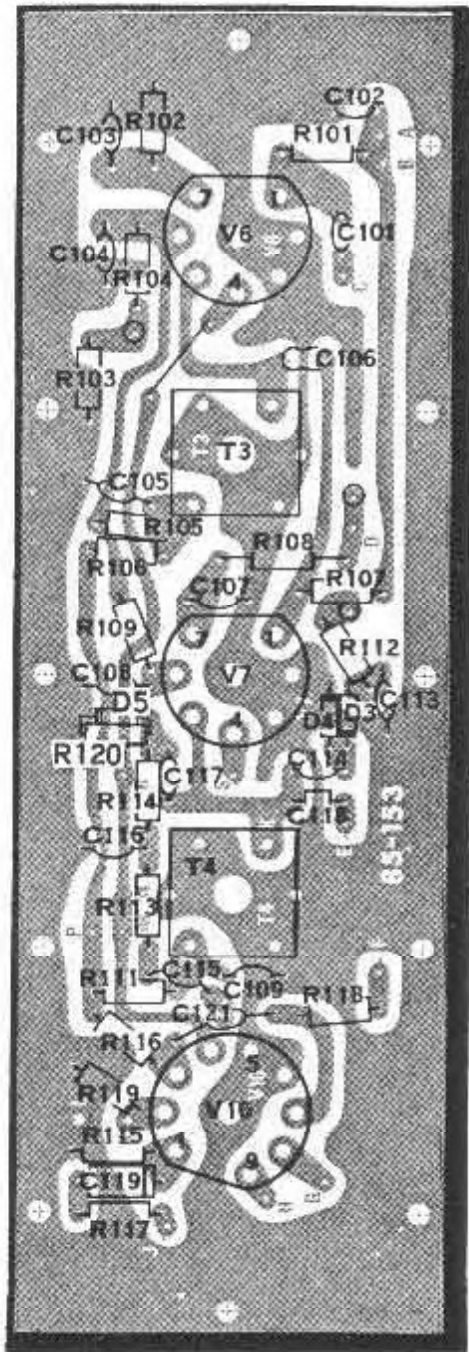

IF CIRCUIT BOARD

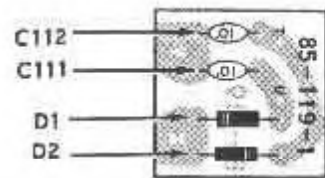

NOISE LIMITER CIRCUIT BOARD

Figure 7-2

# ALIGNMENT

## READING RECEIVER FREQUENCY

To read frequency, add to the BAND switch setting in megahertz, the dial pointer setting in hundreds of kilohertz, and the circular dial setting in kilohertz.

For example (see Pictorial 5-5 on Page 68): If the BAND switch is set to 3,5, the dial pointer is between 2 and 3, and the circular dial is set to 50, the frequency is 3,750 MHz. If the BAND switch is set to 5,7, the dial pointer between 0 and 1, and the circular dial is set to 12, the frequency is 5,712 MHz.

In some of the following steps you will be instructed to set the MAIN TUNING dial at "0 MHz". This means to turn the MAIN TUNING dial so the dial pointer is at "0" on the upper scale, and the circular dial is at "0".

NOTE: A speaker or headphones should be connected whenever the Receiver is turned on.

## HETERODYNE OSCILLATOR PRESET ADJUSTMENT

- ( ) Turn the FUNCTION switch to OPR.
- ( ) Connect a vacuum tube voltmeter with an 11 megohm input impedance between the chassis and test point A on the RF circuit board. Use the voltmeter 5 volt scale to read negative DC volts.

Refer to the following chart and complete each step by adjusting the indicated coil for a -2,7 volts DC indication on the voltmeter. Use the adjustment tool supplied. On one side of the

voltage peak, the voltage will rise and drop in a slow, linear fashion. Use this side of the slope. On the wrong side of the peak, the voltage will drop rapidly. The frequency of each coil is marked on the coil cover in the area designated HET OSCILLATOR. In general, it should not be necessary to turn any coil cores more than 3 turns, from the starting point, to obtain the voltages on the chart.

<u>BAND SWITCH POSITION</u>	<u>ADJUST HET OSCILLATOR COIL</u>
( ) 3,5	3,5
( ) 5,7	5,7
( ) 7,0	7,0
( ) 9,5	9,5
( ) 11,5	11,5
( ) 14,0	14,0
( ) 15,0	15,0
( ) 17,5	17,5
( ) 26,9	26,9

Recheck the adjustment of each coil for proper voltage.

- ( ) Disconnect the vacuum tube voltmeter from the Receiver.

## ZERO BEAT

The term "zero beat" is used several times in this alignment procedure (for example: "tune to zero beat" and "tune to one side of zero beat"). This term can be briefly explained as follows:

When two radio frequencies meet in a circuit, a third frequency is produced (and a fourth that we are not concerned with here) that is equal to the difference between the two original frequencies. This difference frequency decreases and can be heard as an audible tone that decreases in pitch

as the two original frequencies come closer together. When the two original frequencies coincide, no difference frequency (or tone) is produced; at this point, the two frequencies are zero beat with each other. Then as you continue to turn the knob, the tone begins to increase again.

During the alignment of this Receiver, when you zero beat a signal you will have the FUNCTION switch in the CAL position and the MODE switch in CW or USB. You will thus be zero beating the Receiver's crystal calibrator signal against the BFO signal.

## ANTENNA-RF COIL ALIGNMENT

A very accurate but simple way to align the coils of your Receiver is to use the 100 kHz crystal calibration oscillator which is built into the Receiver. However, there may be some who prefer to use a signal generator. Instructions for both methods of coil alignment are given in this section.

To avoid interfering signals, be sure the antenna is disconnected during the Antenna-RF Coil Alignment.

### ALIGNMENT WITH 100 kHz CRYSTAL CALIBRATOR

During alignment with the 100 kHz crystal calibrator you may hear two signals approximately 5 kHz apart near the 0 point, or some of the 100 kHz markings, on your dial. It is important to ALWAYS use the higher frequency signal.

### IF Alignment

NOTE: If at any time during the alignment the S-Meter needle reaches maximum deflection before a peak indication in coil adjustment is obtained, turn the AGC switch to OFF, and continue the adjustment.

( ) Set the front panel controls as follows:

PRESELECTOR - To the proper setting for the band being aligned. See Figure 2-2 (fold-out from Page 70).

RF GAIN - Full clockwise.

BAND - 3.5.

AF GAIN - 3 o'clock.

AGC - FAST.

FUNCTION - CAL.

MODE - USB.

MAIN TUNING - 0 MHz.

( ) Refer to Figure 1-2 (foldout from Page 69) and preset the calibrator trimmer capacitor by positioning the notch as shown.

( ) Tune the MAIN TUNING knob to one side of zero beat, until you obtain a maximum indication on the S-Meter.

( ) Use the alignment tool to adjust IF transformers T3 and T4 for a maximum audio output or S-Meter reading.

### Antenna And RF Amplifier Alignment

NOTE: Be sure to adjust the PRESELECTOR properly during the rest of this Alignment procedure. The proper PRESELECTOR knob setting for each band is shown in Figure 2-2.

( ) All front panel controls should be set as described previously for Alignment With 100 kHz Crystal Calibrator.



Refer to Figure 2-1 (fold-out from Page 70) and complete each step on the Antenna-RF Coil Alignment Chart. For the Receiver Frequency column in each step, first turn the MAIN TUNING to the listed frequency. Then adjust the MAIN TUNING to the side of zero beat that gives a maximum indication on the S-Meter. NOTE: The MAIN TUNING knob must be tuned carefully to keep the signal in the center of the crystal filter's passband. This is indicated by a maximum S-Meter reading.

### OPTIONAL ALIGNMENT USING A SIGNAL GENERATOR

#### IF Transformer Alignment

- ( ) Set the front panel controls as follows:

PRESELECTOR - Anyplace.  
 RF GAIN - Full clockwise.  
 BAND - 3.5.  
 AF GAIN - 3 o'clock.  
 AGC - FAST.  
 FUNCTION - OFF.  
 MODE - AM.  
 MAIN TUNING - 0 MHz.

- ( ) Turn the FUNCTION switch to the OPR (Operate) position and allow the tubes to warm up.
- ( ) Connect the RF output of the signal generator through a .01  $\mu$ f or .001  $\mu$ f disc capacitor to lug 1 of tube socket V6. Use a 1 millivolt signal level. Set the generator for a 3.395 MHz unmodulated signal.
- ( ) Adjust IF transformers T3 and T4 for maximum S-Meter reading. Alternate from T3 to T4 until no further increase can be noticed in the S-Meter reading.

## CRYSTAL CALIBRATOR ALIGNMENT

The crystal calibrator circuit is provided to enable you to accurately calibrate (adjust) your tuning dial every 100 kHz. Two methods of accurately adjusting this circuit are given in this section: Calibration Direct to WWV, and Calibration Using Another Receiver. The WWV method is preferred.

Whenever the FUNCTION switch is placed in the

- ( ) Turn the Receiver OFF and disconnect the signal generator.

### ANTENNA AND RF AMPLIFIER ALIGNMENT

NOTE: It is very important that the PRESELECTOR be adjusted properly during the rest of the Alignment procedure. The proper PRESELECTOR knob settings for the various bands are shown in Figure 2-2.

- ( ) All front panel controls should be set as follows:

PRESELECTOR - To the proper setting for the band being aligned, See Figure 2-2.  
 RF GAIN - Full clockwise.  
 BAND - In accordance with the chart in Figure 2-1.  
 AF GAIN - 3 o'clock.  
 AGC - FAST.  
 FUNCTION - Operate.  
 MODE - USB.  
 MAIN TUNING - In accordance with Figure 2-1, Antenna-RF Alignment Chart (fold-out from Page 70).

- ( ) Connect the RF output of the signal generator to the ANTENNA jack on the rear of the Receiver.
- ( ) Adjust the coils designated in Figure 2-1 for maximum S-Meter reading or maximum audio. Use the alignment tool furnished. Usually, not more than three turns will be required.

CAL position, you should be able to hear a harmonic (multiple) of the calibration oscillator at each 100 kHz dial marking.

- ( ) Refer to Figure 1-2 (fold-out from Page 69) and be sure the notch of the Calibration Trimmer capacitor on the RF Circuit Board is set as shown.

## RADIO STATION WWV

Radio station WWV is operated by the National Bureau of Standards and is located near Fort Collins, Colorado. It transmits extremely accurate frequency and time signals which are widely used as standards by both science and industry.

The signals of station WWV are most easily identified as a steady signal (carrier), frequently modulated with tones of 440 or 600 Hz, and further modulated by a "tick" at one second intervals. Other modulation is also used. Identify the station positively by the voice announcements every five minutes.

## CALIBRATION DIRECT TO WWV

( ) Set the front panel controls as follows:

RF GAIN - Fully clockwise,  
 BAND - 15,  
 AF GAIN - 3 o'clock,  
 AGC - FAST,  
 FUNCTION - OPR,  
 MODE - USB,  
 MAIN TUNING - 0,  
 PRESELECTOR - 15.5 MHz (Figure 2-2).

( ) Connect the antenna to the rear apron phono socket. Use one of the phono plugs provided.

( ) Peak the PRESELECTOR for maximum noise or signal.

( ) Turn the MAIN TUNING knob back and forth. Station WWV should be heard very close to the 0 mark on the circular dial (within 1 to 3 kHz).

( ) Adjust the MAIN TUNING knob so that the tone from WWV goes lower in frequency and just disappears.

( ) Turn the FUNCTION switch to CAL. The tone from the calibrator should be heard.

( ) Adjust the Trimmer Capacitor (Figure 1-2, fold-out from Page 69) on the RF Circuit Board so the calibrator tone descends in frequency and just disappears. The calibration oscillator is now in zero beat with

WWV. Set the FUNCTION switch to OPR and then back to CAL to be sure you have a true zero beat.

## CALIBRATION USING ANOTHER RECEIVER

( ) Set the front panel controls as follows:

PRESELECTOR - Anyplace,  
 RF GAIN - Full clockwise,  
 BAND - 3.5 MHz,  
 AF GAIN - 3 o'clock,  
 AGC - FAST,  
 FUNCTION - OFF,  
 MODE - USB,  
 MAIN TUNING - 3.5 MHz.

( ) Couple the antenna connector of the SB-310 Receiver to the antenna connector of another receiver capable of receiving WWV at 2.5 MHz, 5 MHz, 10 MHz, or 15 MHz. If this is not possible, a receiver tuned to a standard broadcast station, operating at an even multiple of 100 kHz, can be used.

( ) Turn ON the SB-310 Receiver and the other receiver. Set the FUNCTION switch of the SB-310 Receiver to the CAL position. Turn the SB-310 Receiver AUDIO GAIN control fully counterclockwise.

( ) Tune the other receiver to WWV or a standard broadcast station as described above. Adjust the Calibrator Trimmer capacitor on the RF circuit board, with an insulated screwdriver for a "zero beat" in the other receiver. When WWV is used, the period when no tone modulation is present allows easier identification of the zero beat. Zero beat is the point at which a harmonic of 100 kHz corresponds to the frequency of the station tuned in on the receiver. As zero beat is approached, a tone that decreases in frequency until it finally stops, will be heard from the receiver. Set the FUNCTION switch to OPR and then back to CAL to be sure you have a true zero beat.

## LMO SHIFTER AND DIAL ADJUSTMENTS

### LMO SHIFTER ADJUSTMENT

This adjustment can be made only when the SSB crystal filter and the LSB BFO crystal are installed. If you have not installed these accessory items, proceed to Dial Calibration; however, you should remember to make the LMO Shifter Adjustment should the accessory filter and BFO crystal be purchased at some future time.

The purpose of this adjustment is to insure that the LMO remains at zero beat when it is shifted from one sideband to the other.

- ( ) Set the Main Tuning for 3.8 MHz.
- ( ) Turn the FUNCTION switch to CAL, and the MODE switch to USB. Carefully zero beat the calibrator signal, using the Main Tuning knob, and peak the PRESELECTOR.
- ( ) Turn the MODE switch to the LSB position. Be careful not to touch the Main Tuning dial. Now note that the calibrate signal may or may not be exactly at zero beat in the LSB position. Turn the FREQUENCY SHIFT adjustment (on the LMO) for an exact zero beat in the LSB mode. Recheck the zero beat in the USB mode to be certain of the adjustment. Repeat the procedure if necessary.

### DIAL CALIBRATION

- ( ) Zero beat the crystal calibrator at 3.8 MHz.

- ( ) Set the adjustable index line in the center of the circular dial window.
- ( ) Remove the knob from the MAIN TUNING shaft without disturbing the zero beat.
- ( ) Place a screwdriver through the hole in the dial escutcheon directly above the MAIN TUNING shaft and into the LMO dial drive shaft.
- ( ) Hold the LMO drive shaft on zero beat and loosen the setscrew in the circular dial bushing. Turn the circular dial until the 0 is directly under the adjustable index line. Now tighten the setscrew.
- ( ) Make sure that the circular dial turns freely and that the nylon spiral follower is properly engaged in the spiral before proceeding.
- ( ) Replace the knob on the MAIN TUNING shaft.
- ( ) Readjust the Heterodyne Oscillator coils for maximum S-Meter reading. Be sure to adjust the coil on the side of the peak with the slow rise and fall of voltage.

This completes the Alignment of your Heathkit SB-310 Receiver.

# CIRCUIT DESCRIPTION

Refer to the Block Diagram (fold-out from Page 92) and the Schematic (fold-out from Page 105) when reading the Circuit Description. To help you locate parts on the Schematic, the letter-number designations for the parts have been coded as follows:

- 1 to 99 Parts on the RF Circuit Board.
- 100 to 199 Parts on the IF Circuit Board.
- 200 to 299 Parts on the Chassis .

NOTE: To make the various functions of the Receiver easier to understand, a lower sideband frequency of 3,895 megahertz will be used when tracing through the circuit in this description. All switches are shown in appropriate positions on the Schematic. The following chart lists the various frequencies that will be found throughout the Receiver. The first line indicates the frequencies referred to in the Circuit Description.

BAND	HETERODYNE OSCILLATOR FREQUENCY	RECEIVED SIGNAL FREQUENCY	PASSBAND SIGNAL FREQUENCY	LMO MIXER OUTPUT	LMO
3.5 to 4.0	12.395	3.895	8.5	3.395	5.105
5.7 to 6.2	14.595	6.0	8.595	3.395	5.2
7.0 to 7.5	15.895	7.2	8.695	3.395	5.3
9.5 to 10.0	18.395	9.8	8.595	3.395	5.3
11.5 to 12.0	20.395	11.6	8.795	3.395	5.4
14.0 to 14.5	22.895	14.2	8.695	3.395	5.3
15.0 to 15.5	23.895	15.2	8.695	3.395	5.3
17.5 to 18.0	26.395	17.5	8.895	3.395	5.5
26.9 to 27.4	35.795	27.4	8.395	3.395	5.0

Frequencies in Megahertz

## RF AMPLIFIER

The received signal is connected from the antenna to BS5R (band switch, wafer 5, rear of wafer). BS5R selects the primary of the antenna coil and BS4F (band switch, wafer 4, front of wafer) selects the secondary of the antenna coil for the band being used. Each tuned circuit consists of a coil and capacitor combination which resonates at frequencies within the band in use. The signal, after passing through coil L1, is connected to C201C and C201D by a tie pin that connects the selector contacts of BS4F and the entire rotor portion of BS4R. Capacitors C201C and C201D are adjusted by the Preselector control to tune the grid circuit of V1, the RF amplifier, to the desired frequency in the 3.5 megahertz band. Only capacitor C201C is used on the 14.0, 15.0, 17.5, and 26.9 MHz bands.

The plate circuit of V1 is tuned to the same frequency as the grid circuit by capacitors C201A and C201B, and coil L7. The plate coil for the band being used is selected by BS3F, and the appropriate tuning capacitor is selected by the use of a tie pin to BS3R. Plate voltage is supplied to this stage through the same tie pin. Only capacitor C201A is used for the 14.0, 15.0, 17.5, and 26.9 MHz bands.

## HETERODYNE OSCILLATOR AND FIRST MIXER

The amplified signal from V1 is coupled through capacitor C14 to the grid of V2, the first mixer. Also being fed to the grid of V2 is a highly stable crystal-controlled signal from V4, the heterodyne oscillator. BS1R selects the proper crystal for the band being used. In this case Y1 is switched into the grid circuit of V4 to produce an oscillator frequency of 12.395 megahertz.

The plate circuit of V4 is tuned by coils L13 through L21. The proper coil is connected to BS2R and through a tie pin at BS2F to the plate of tube V4. B+ voltage follows this same path.

The received signal of 3.895 megahertz and the oscillator signal are mixed in V2 to produce the sum and difference frequencies of 16.29 and 8.5 megahertz, respectively. Passband coupler T2 is designed to pass only frequencies in a range

between 8.395 and 8.895 megahertz, and to greatly attenuate all other frequencies. The 16.29 megahertz frequency, being too high, is attenuated, whereas the difference frequency of 8.5 megahertz passes through T2 without attenuation.

## LINEAR MASTER OSCILLATOR (LMO) AND SECOND MIXER

The 8.5 megahertz signal from T2 is coupled to the grid of V3, the second mixer. Coupled to the cathode of V3 is a signal from the tunable LMO. The LMO, consisting of tube V5 with its associated circuit, forms a very stable linear oscillator that operates over a frequency range of 5 to 5.5 megahertz. Varying the Main Tuning changes the frequency of the LMO and thus changes the operating frequency of the Receiver. The frequency at which the LMO operates is always the difference between the output frequency from the passband filter, T2, and the 3.395 megahertz IF frequency.

In this instance, a signal at 3.895 megahertz beating with the heterodyne oscillator frequency of 12.395 megahertz produces an output frequency of 8.5 megahertz. An LMO frequency of 5.105 megahertz is required to obtain the 3.395 megahertz IF frequency.

The output signal from V3 is passed through the crystal filter for bandwidth selectivity. The input and output of SSB (single sideband), CW, or AM crystal filters are selected by MS2R (Mode switch, wafer 2, rear of wafer) and MS1F respectively.

Only the AM filter is furnished with the Receiver. The CW and SSB filters may be obtained as accessories. See Figure 6-1 for the bandpass characteristic of each filter, and Page 82 for their operational use.

## IF AMPLIFIERS

The signal is then fed through capacitor C101, and through stages V6 and V7, the first and second IF amplifiers. These stages are high gain voltage amplifiers. T3 and T4 are tuned for maximum gain per stage.

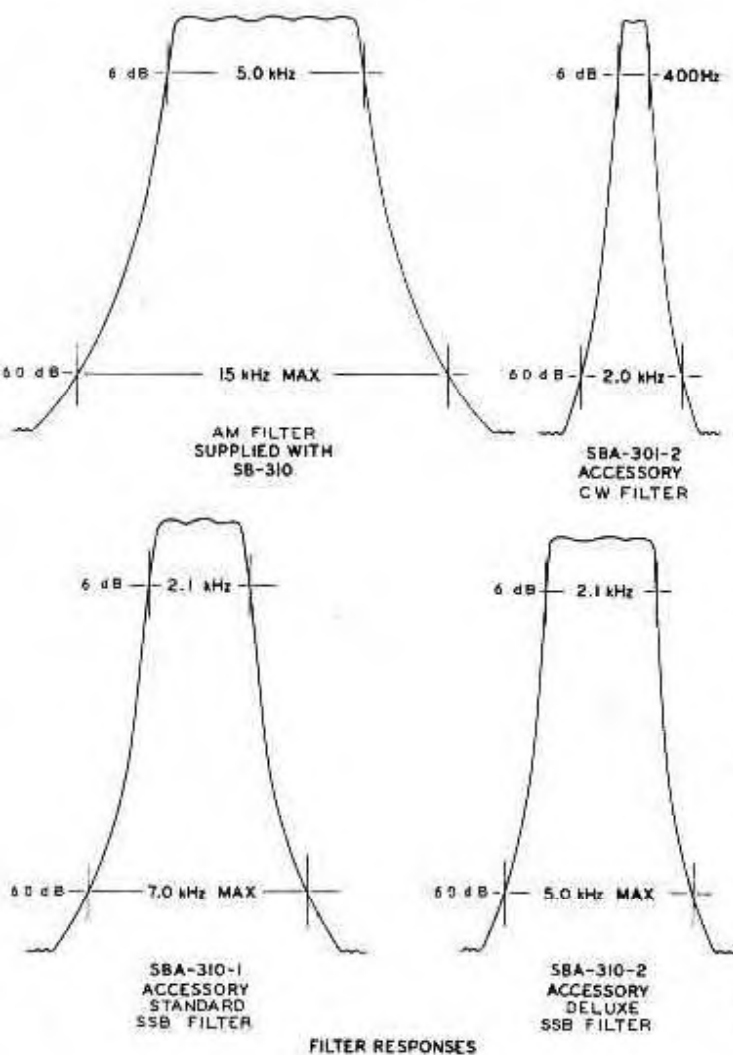

Figure 6-1

The "S" meter is connected in the IF circuits to indicate received signal strength. The S-Meter Adjust control is adjusted for zero S-units with the antenna disconnected and the RF Gain control fully clockwise.

## NOISE LIMITER

The noise limiter circuit, which consists of diodes D1 and D2, capacitors C111 and C112, and resistor R235, is a full-wave, shunt-type diode limiter. The limiter is self-biased and automatically adjusts itself to the degree of modulation of the received signal.

The advantage of this self-biasing type of limiter is that as the signal level moves up or down, the point at which it starts to limit also moves up or down. The ANL (automatic noise limiter) switch is located on the AF Gain control. The control knob is pulled out to turn the limiter on.

## AGC

The desired amount of amplification for the RF and IF amplifiers is determined by the negative grid bias set by the RF Gain control. Also present on this same line is the AGC (automatic gain control) voltage. This voltage is obtained by coupling a portion of the IF output signal through capacitor C114 to AGC diodes D3 and D4. These diodes produce a negative DC voltage proportional to the signal strength. A signal producing a negative AGC voltage higher than the preset bias voltage causes the gain of V1, V6, and V7 to be reduced below the preset level. This produces an output level from the first RF and IF amplifier stages that remains nearly constant in spite of wide changes in the amplitude of the received signal.

The AGC action is instantaneous. However, the length of time it remains in control is determined by capacitors C114 and C228 along with resistor R112. These capacitors are charged by the AGC voltage when a higher than normal signal is received; C114 has a fast rate of discharge, and C228 a slow rate of discharge. The capacitors discharge through resistors R208 and R214, and the RF Gain control. Because resistor R208 is so much larger than R214 and the RF Gain control, changing the setting of the RF Gain control has very little effect on the discharge time of capacitors C114 and C228. The AGC switch places only one of these capacitors in the circuit at a time.

## PRODUCT DETECTOR/BFO

Tube V9 is made up of three triodes. The IF output signal in the LSB, USB, and CW modes is fed through capacitor C118 to the grid of the product detector, V9A. V9B serves as a BFO (beat frequency oscillator). The frequency at which V9B oscillates is determined by crystals Y10 and Y11. These crystals are selected by MS4R.



With the Mode switch in the LSB position, crystal Y10 is selected to produce a carrier frequency of 3393.6 kHz.

If USB (upper sideband) operation is desired, the Mode switch is placed in the USB position. MS4R switches crystal Y11 into the circuit, increasing the operating frequency of the BFO by 2.8 kilohertz. When this is done, the LMO frequency must also be changed 2.8 kilohertz, but in the opposite direction. These frequency changes result in changing to the upper sideband without changing the receiver main tuning. The change in operating frequency of the LMO is done by a switching diode in the LMO.

### AF AMPLIFIERS

The audio output signal results from mixing the IF and BFO frequencies in the Product Detector.

The audio signal is coupled through capacitor C242 to MS4R. From MS4R the signal is fed

to the grid of V10A, the first audio amplifier. This amplified signal is coupled through capacitor C121 to V10B, the second audio amplifier. The signal is then coupled through output transformer T5 to a speaker or headphones. From the secondary of T5, an 8  $\Omega$  output is available for speaker operation, and a high impedance output is available for headphone operation. A 500  $\Omega$  audio output is also available. Resistor R117 and capacitor C119 from the secondary of T5 to the cathode of V10A form a negative feedback circuit. The negative feedback circuit is used to provide a low distortion, stable audio output power of 1 watt.

### AM DETECTION

In the AM mode, the BFO is turned off and the Product Detector is disconnected from the audio amplifier by MS4R. The IF output signal is coupled through capacitor C117 to D5, the AM detector diode. RF signals are bypassed to ground through capacitor C116. The resulting amplitude-detected audio signal is routed

by MS4R to the AF Gain control and to audio amplifier stages V10A and V10B. The setting of the AF Gain control determines the audio output level from the Receiver. The detected audio from either the product detector or the AM detector is also fed to the grid of cathode follower V9C. The cathode follower maintains a low level, low impedance output suitable for the "tuner" input of a hi-fi amplifier.

### CRYSTAL CALIBRATOR

The 100 kHz signal produced by V8, the crystal controlled calibrator stage, is coupled to the Receiver input. This signal can be used at any time to check dial calibration by placing the Function switch in the CAL position, and the Mode switch in the LSB or USB position. Zero beat cannot be heard in the CW mode due to the narrow passband of the CW filter, nor in the AM mode due to the absence of BFO injection.

### MUTE JACK

The Mute jack on the rear of the Receiver is used to bias receiver tube stages V1, V2, V6, V7, and V10B to cutoff for muting.

To use the Mute feature, the Function switch is placed in the STBY position. Then, when the Mute line is grounded, the Receiver changes to the OPR condition.

### POWER SUPPLY

The power supply uses a transformer for isolation from the AC line. Diodes D6 and D7 are used in a full-wave rectifier circuit. The B+ voltage is filtered by four-section capacitor C232 and resistors R215, R216, and R217. Diode D8 is used to develop negative voltage for use as bias. Transformer T1 includes a separate secondary winding for the tube filament and pilot lamp voltage. It has two primary windings which may be wired for either a 120 or 240 volt supply line.



## CHASSIS PHOTOGRAPHS

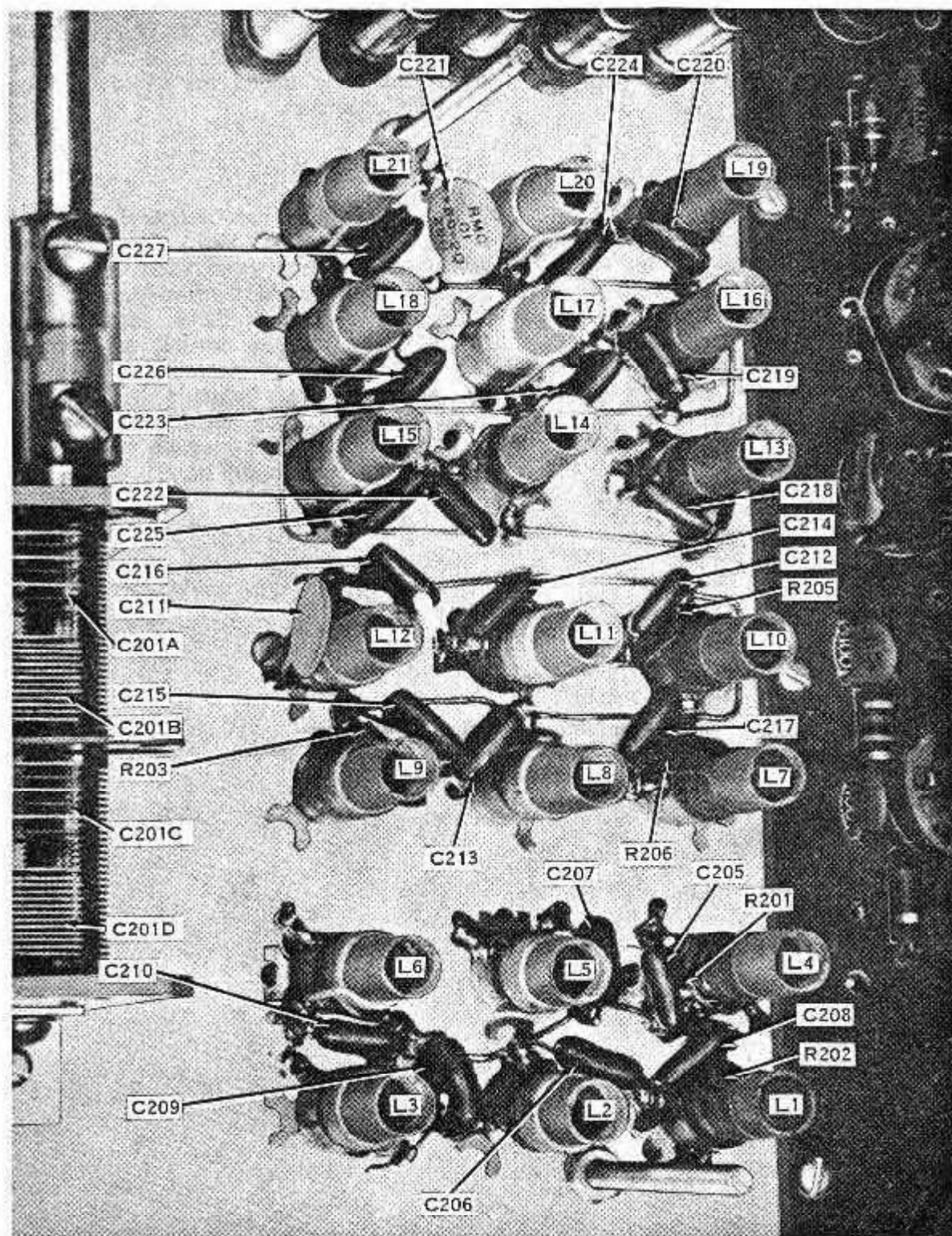

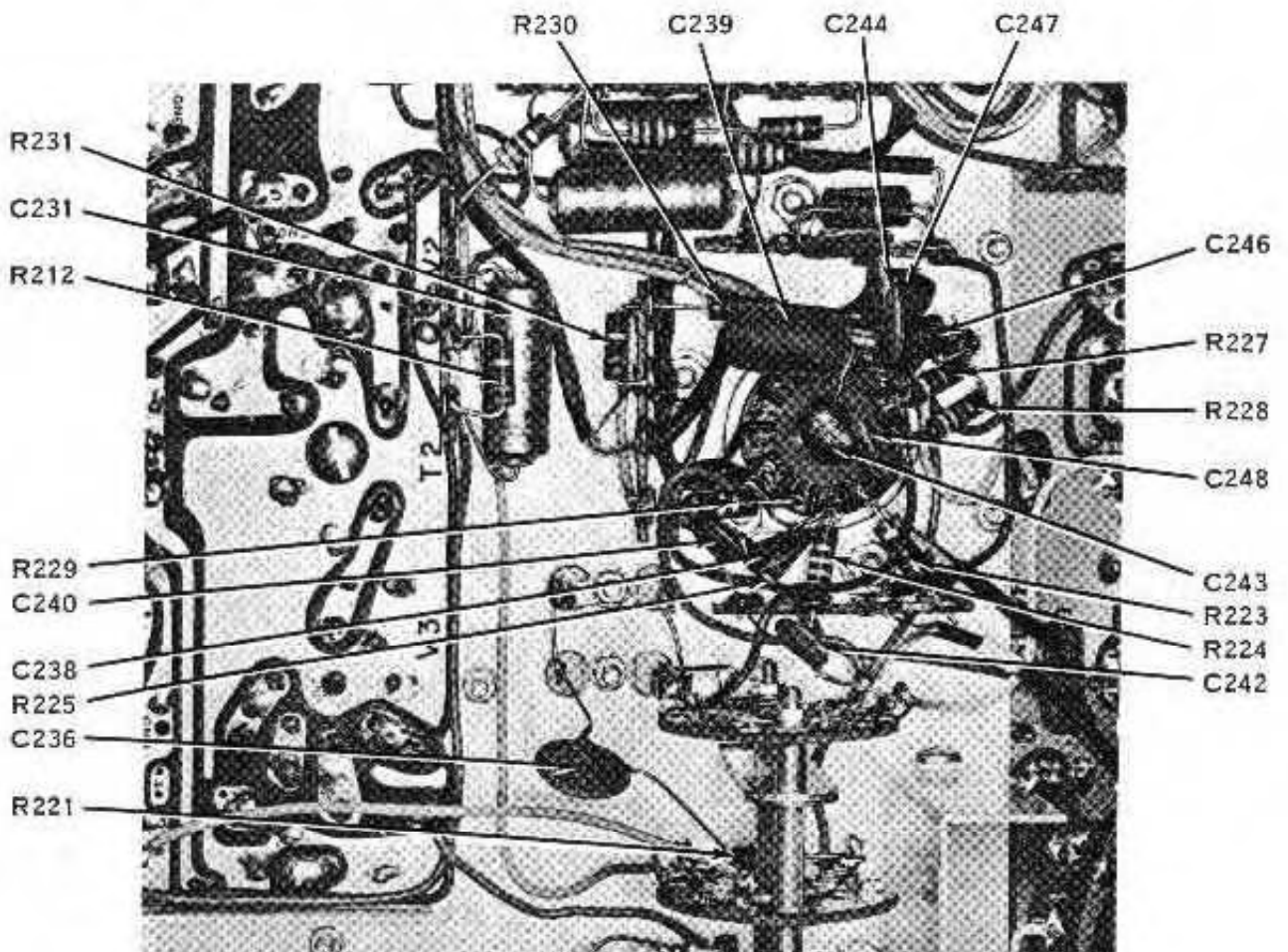
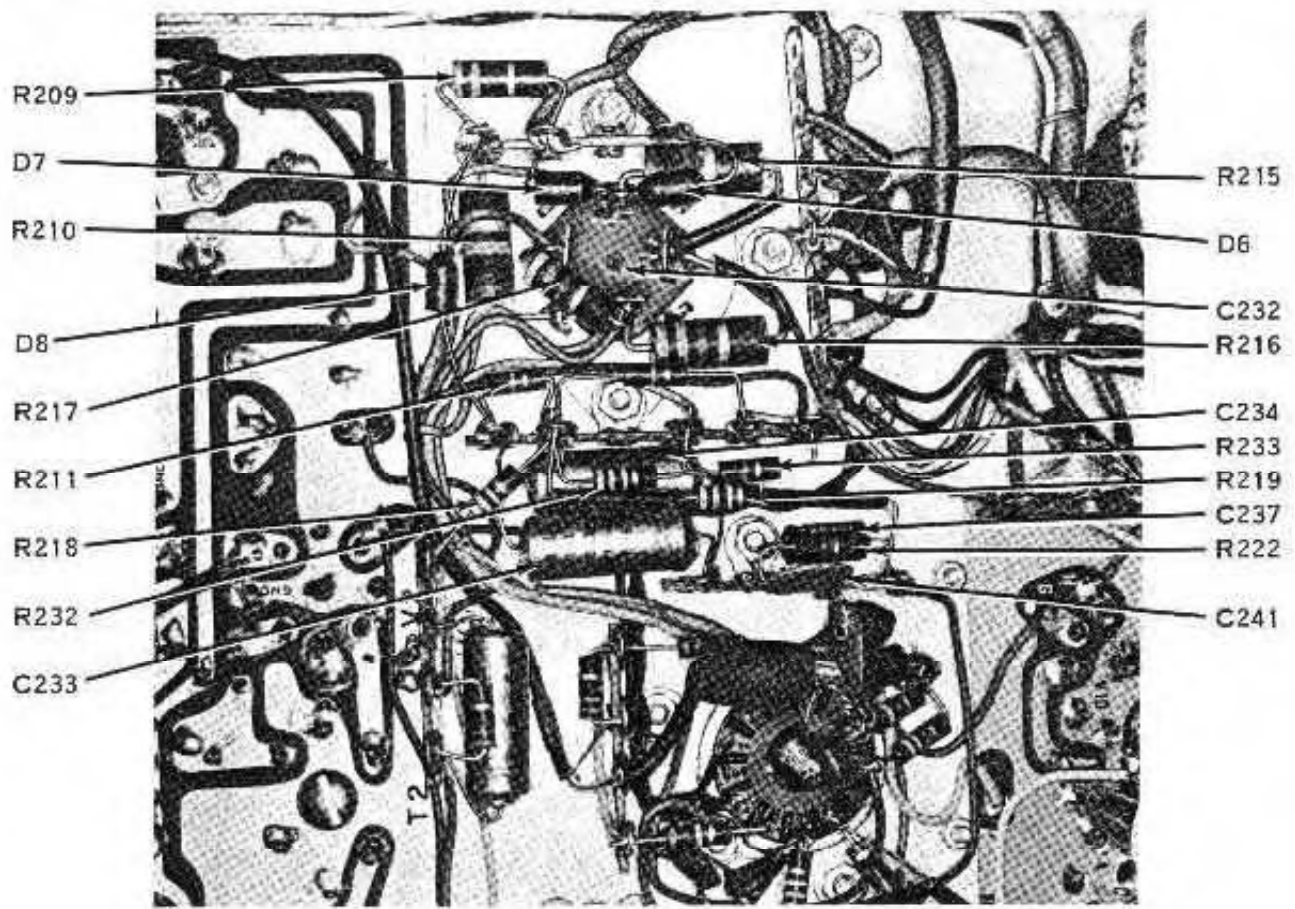

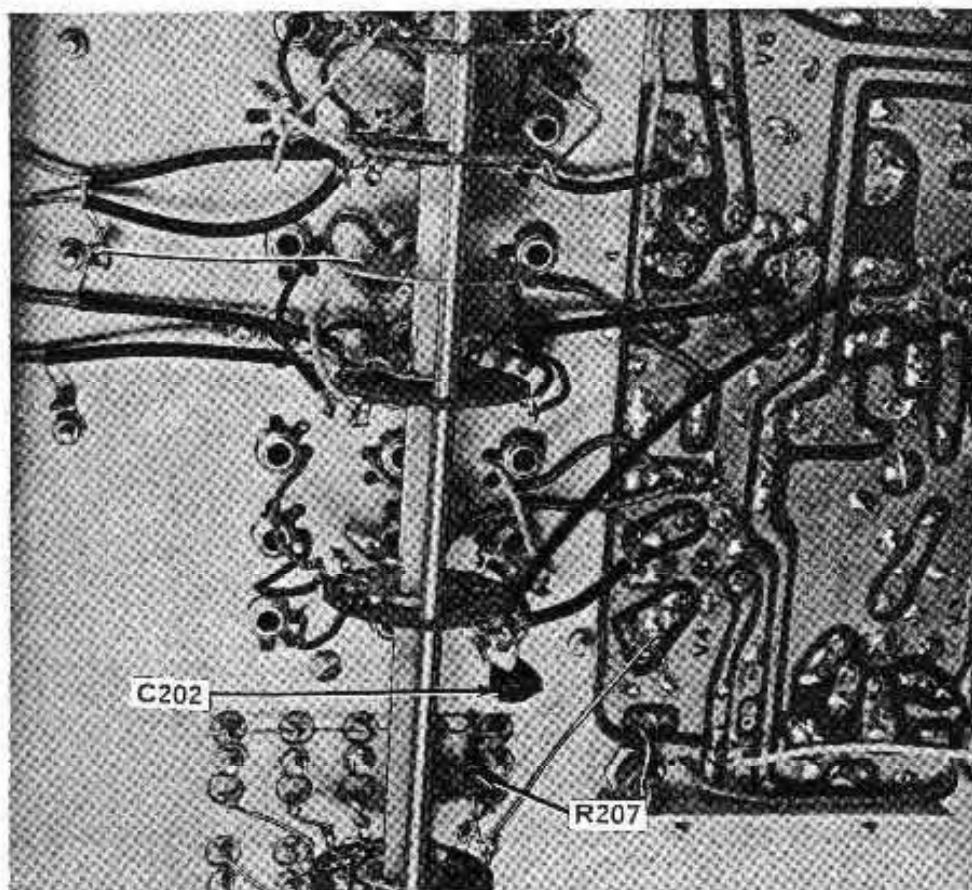
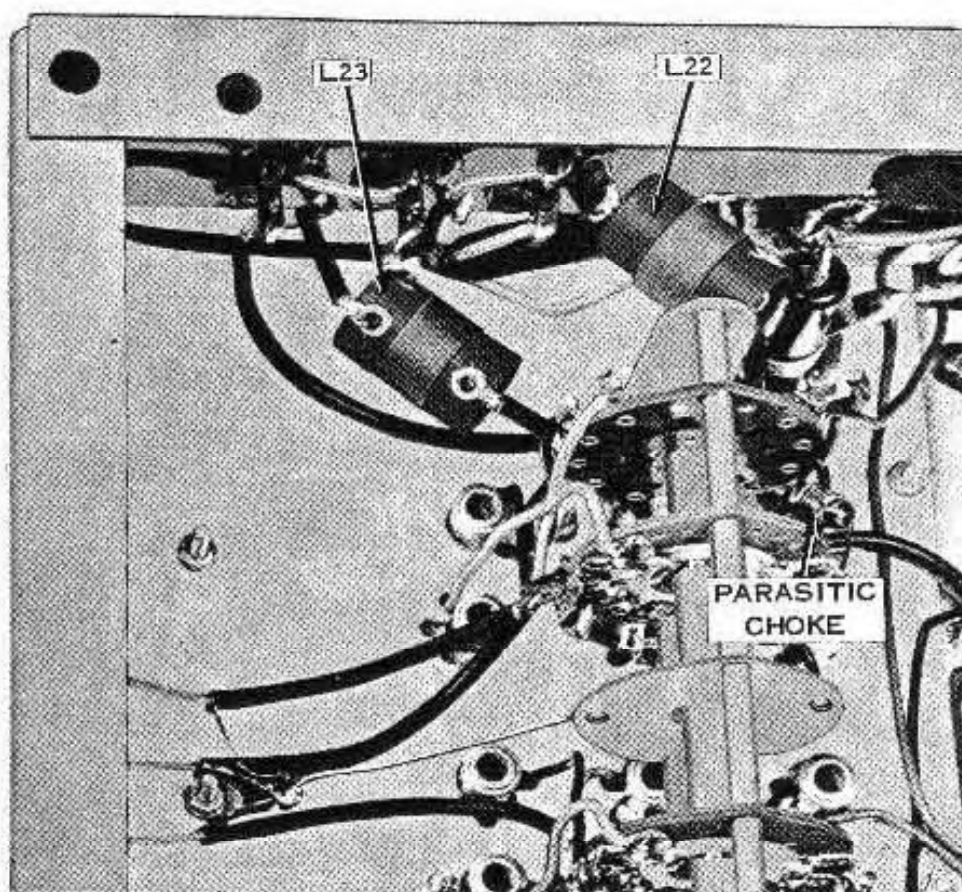

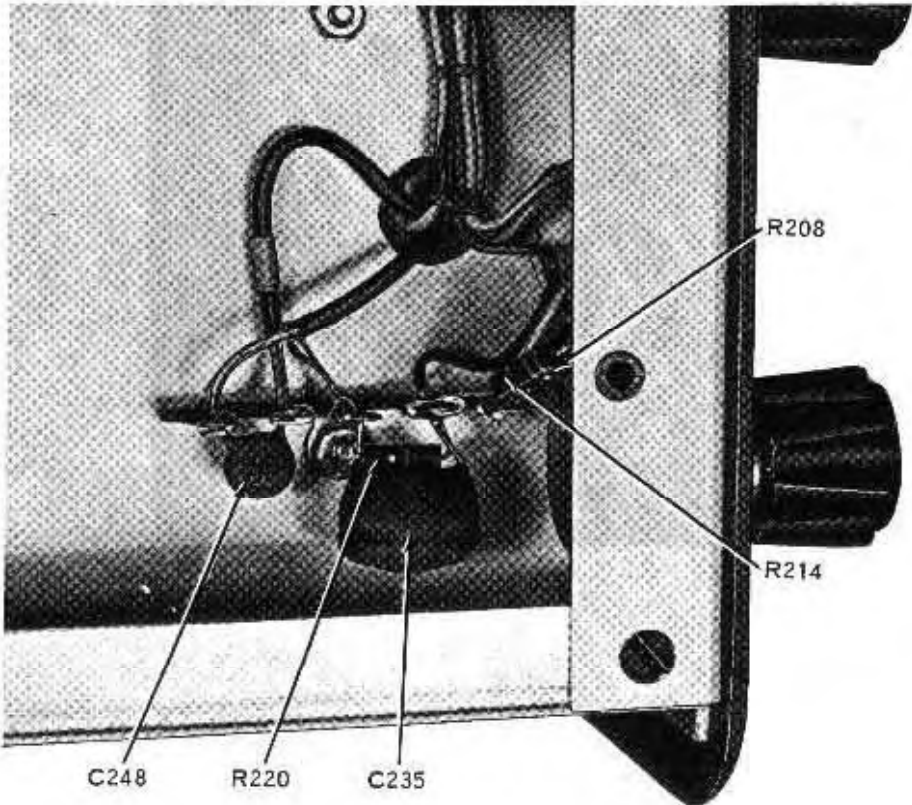
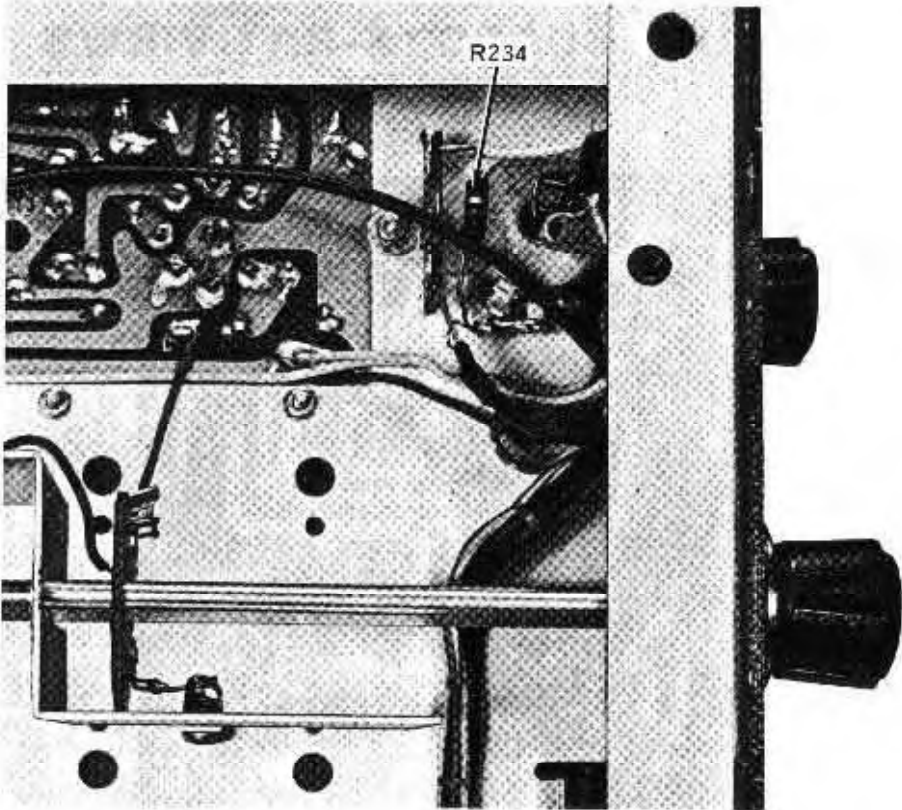

### LMO SCHEMATIC

6CB6

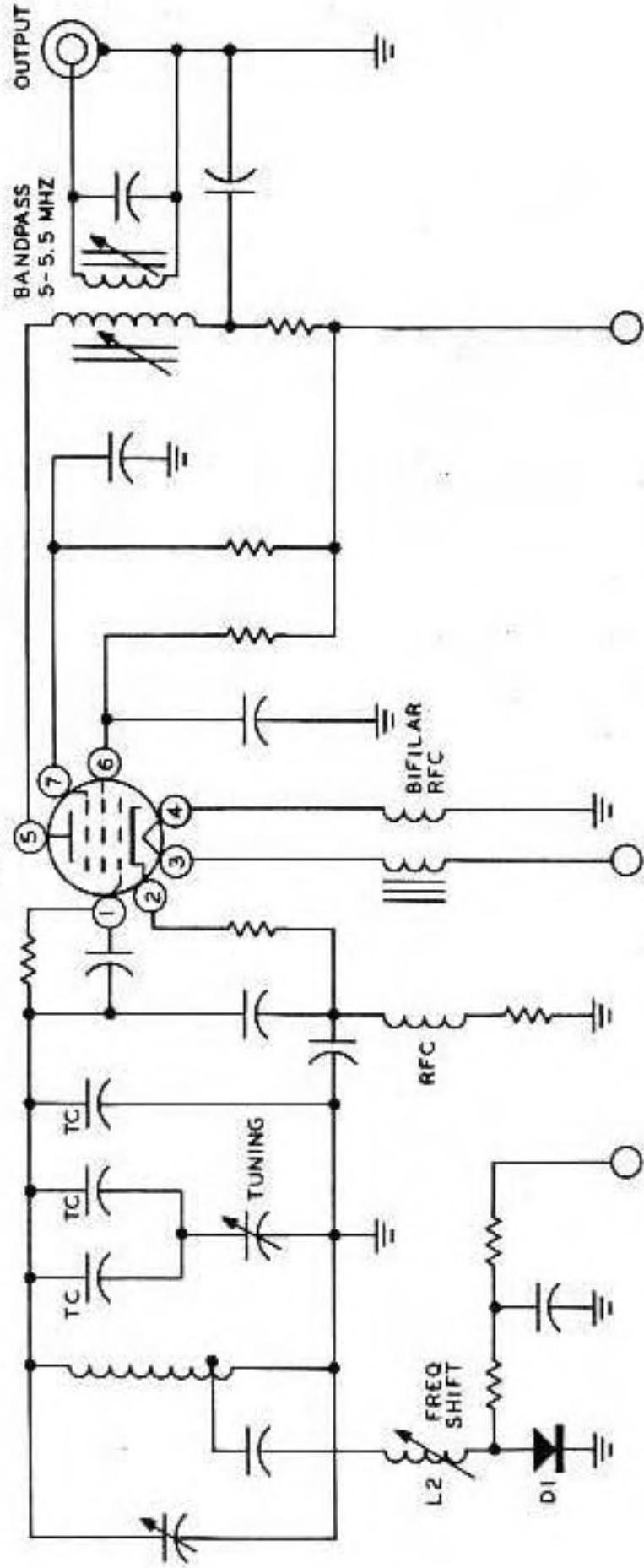

# ANTENNA-RF COIL ALIGNMENT CHART

SET BAND SWITCH TO	RECEIVER FREQUENCY	SET PRESELECTOR* FOR	ADJUST FOR MAXIMUM
( ) 3.5 MHz	3.5 MHz	3.5	ANTENNA coil 3.5
( ) **3.5 MHz	3.5 MHz	3.5	RF AMPLIFIER coil 3.5
( ) 7.0 MHz	7.5 MHz	7.5	ANTENNA coil 7.5
( ) 7.0 MHz	7.5 MHz	7.5	RF AMPLIFIER coil 7.5
( ) 9.5 MHz	9.5 MHz	9.5	ANTENNA coil 9.5
( ) 9.5 MHz	9.5 MHz	9.5	RF AMPLIFIER coil 9.5
( ) 15.0 MHz	15.5 MHz	15.5	ANTENNA coil 15.5
( ) 15.0 MHz	15.5 MHz	15.5	RF AMPLIFIER coil 15.5
( ) 17.5 MHz	17.5 MHz	17.5	ANTENNA coil 17.5
( ) 17.5 MHz	17.5 MHz	17.5	RF AMPLIFIER coil 17.5
( ) 26.9 MHz	27.4 MHz	27.4	ANTENNA coil 27.4
( ) 26.9 MHz	27.4 MHz	27.4	RF AMPLIFIER coil 27.4

\* See Figure 2-2.

\*\* Upon completion of this step, readjust transformers T3 and T4 for maximum to compensate for any error in the preceding IF Alignment.

This completes the IF antenna, and RF alignment of the Receiver. The signal generator, if one was used, should be disconnected from the Receiver. Now perform the steps under Crystal Calibrator Alignment.

FIGURE 2-1

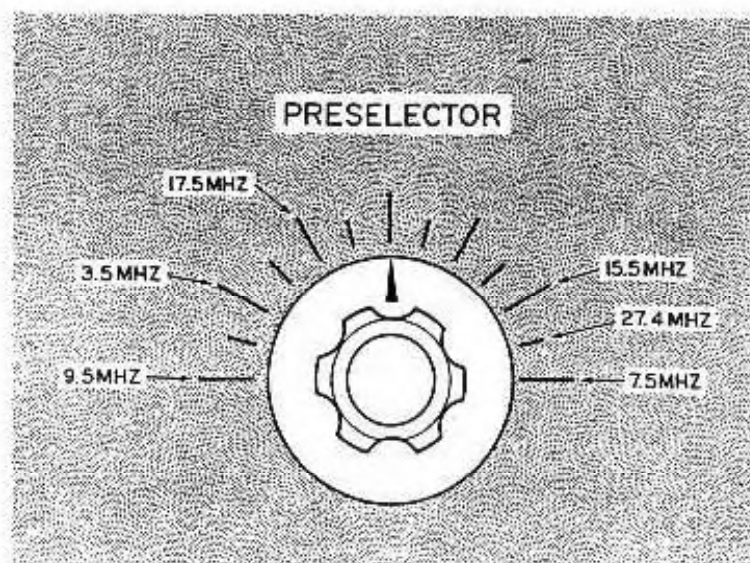
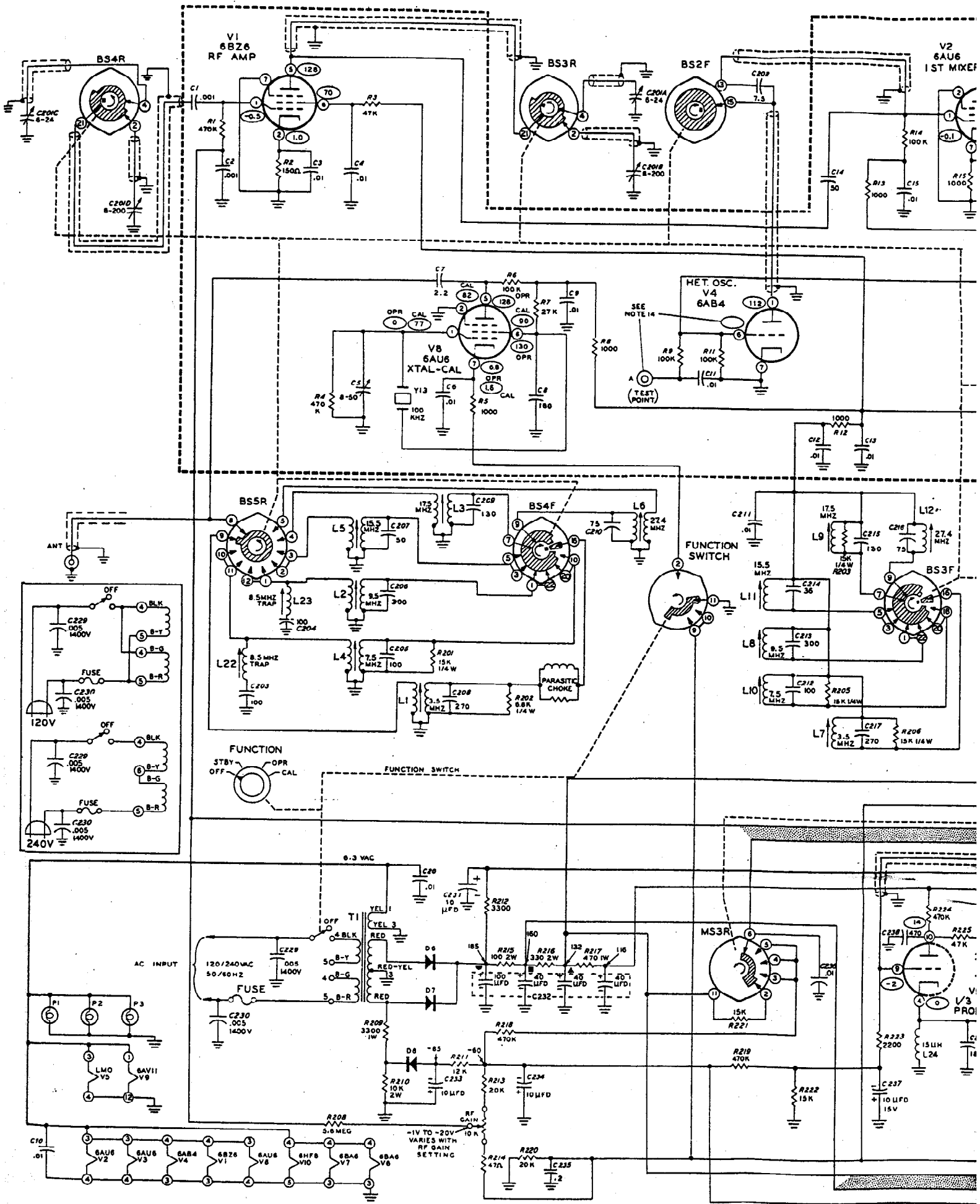
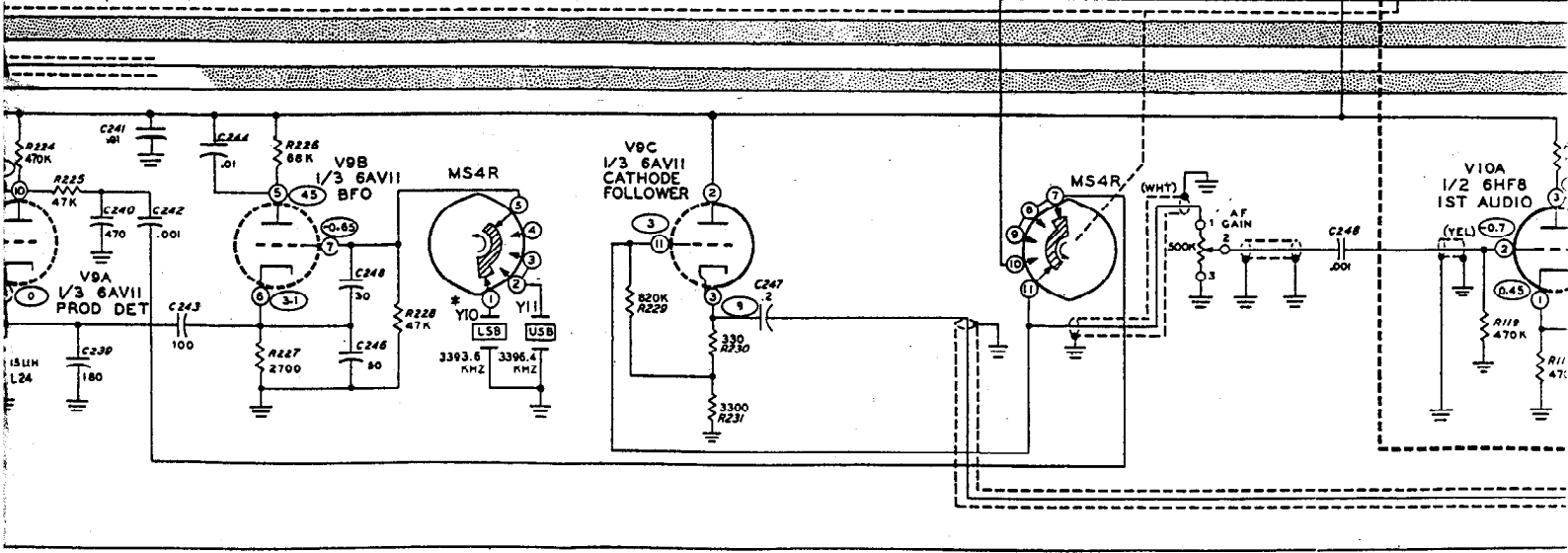
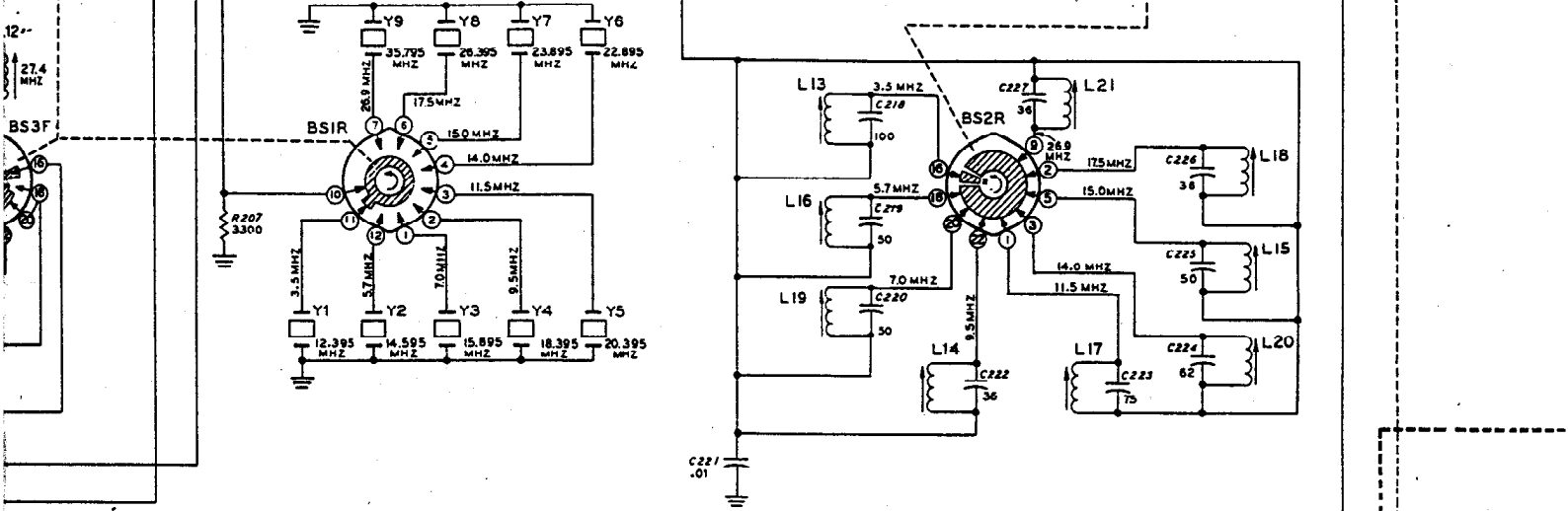
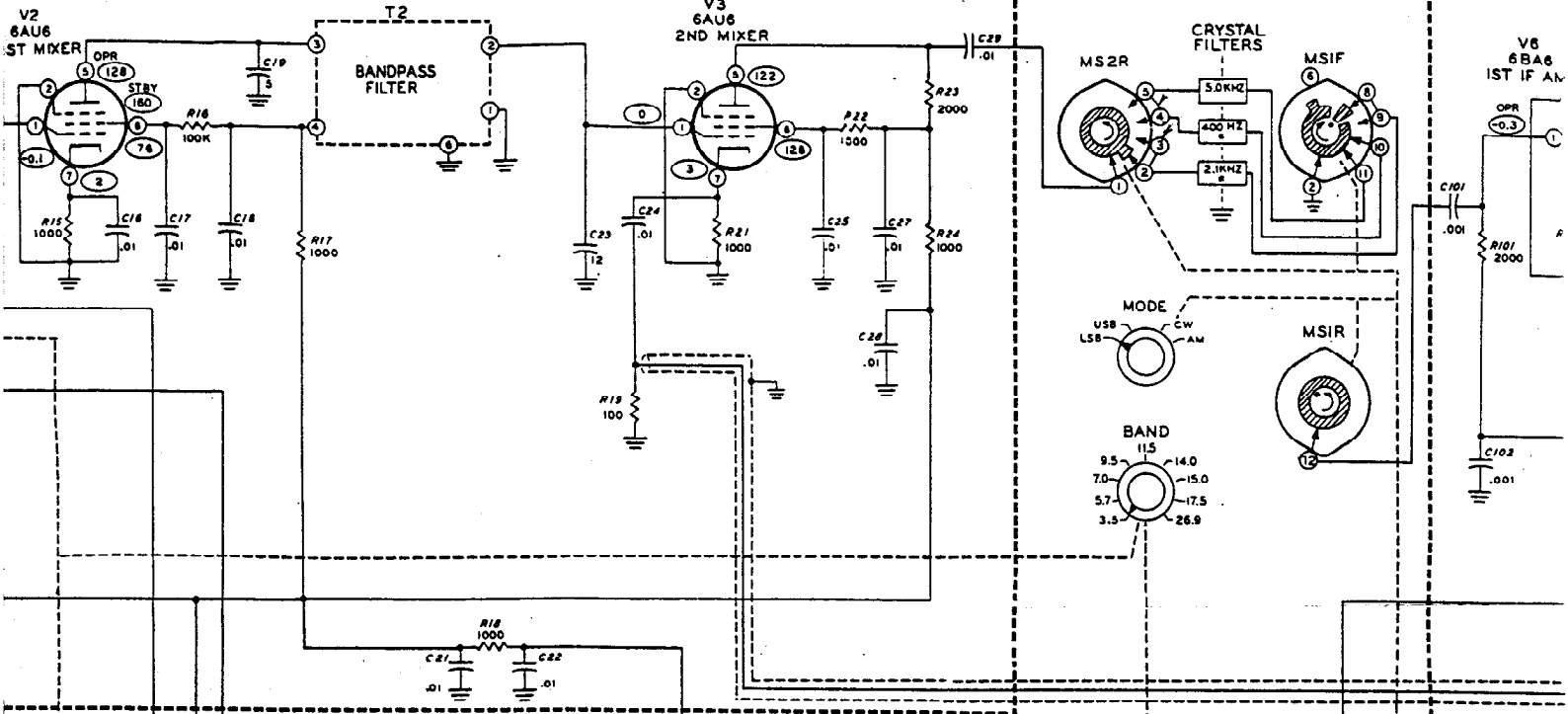

FIGURE 2-2



RF CIRCUIT BOARD





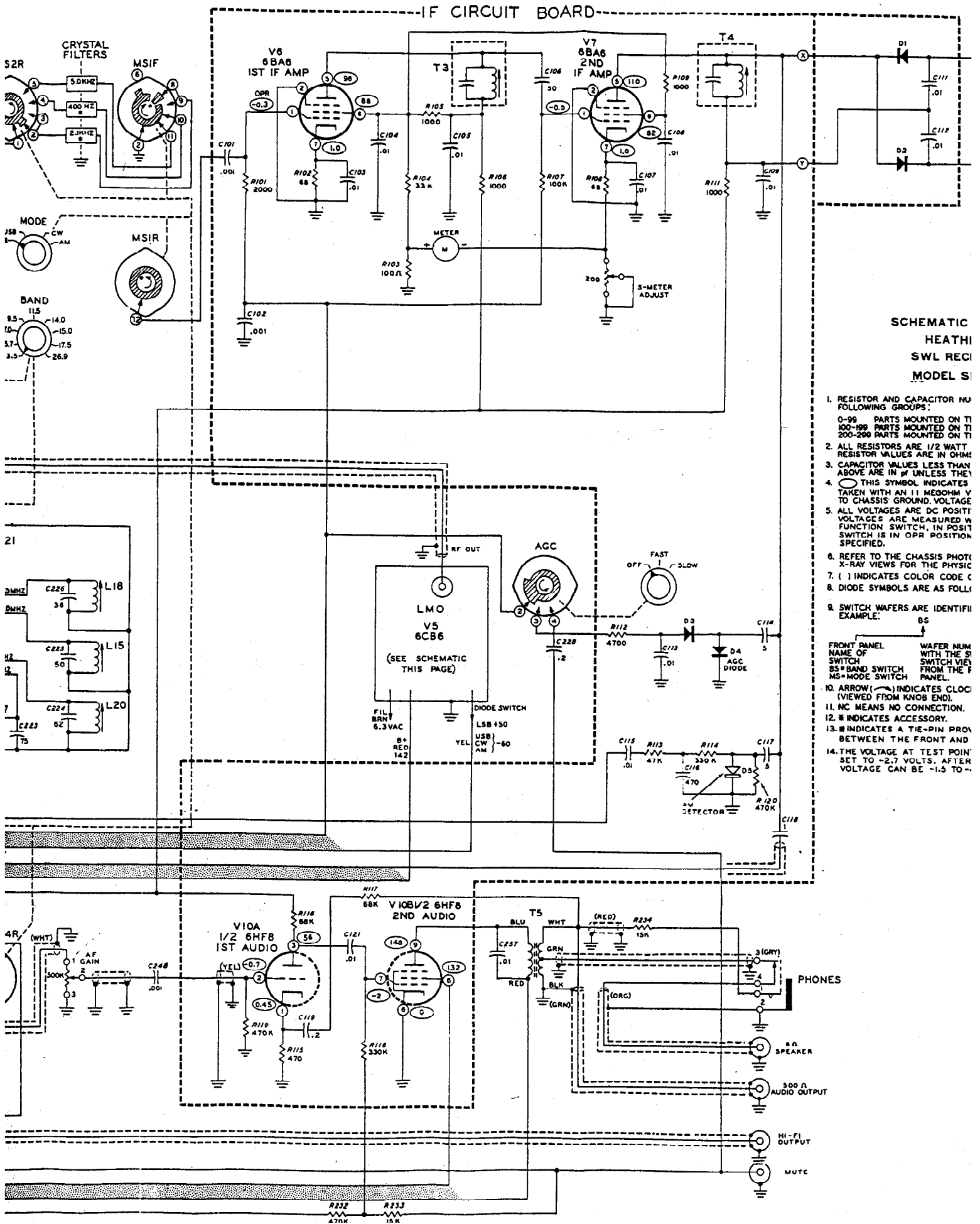

**SCHEMATIC  
HEATHKIT  
SWL RECI  
MODEL S1**

1. RESISTOR AND CAPACITOR NUMBERS GROUPED AS FOLLOWS:  
0-99 PARTS MOUNTED ON T1  
100-199 PARTS MOUNTED ON T2  
200-299 PARTS MOUNTED ON T3
2. ALL RESISTORS ARE 1/2 WATT UNLESS OTHERWISE SPECIFIED.
3. CAPACITOR VALUES LESS THAN 100 ARE IN PICO FARADS UNLESS OTHERWISE SPECIFIED.
4. THIS SYMBOL INDICATES A POINT TO BE TAKEN WITH AN 11 MEGOHM VOLTAGE TO CHASSIS GROUND. VOLTAGE IS MEASURED WITH FUNCTION SWITCH IN POSIT SWITCH IS IN OPR POSITION SPECIFIED.
5. REFER TO THE CHASSIS PHOTO X-RAY VIEWS FOR THE PHYSICAL LOCATION OF THE POINTS.
6. REFER TO THE CHASSIS PHOTO X-RAY VIEWS FOR THE PHYSICAL LOCATION OF THE POINTS.
7. ( ) INDICATES COLOR CODE ( ) INDICATES ACCESSORY.
8. DIODE SYMBOLS ARE AS FOLLOWS:  
D1, D2, D3, D4, D5
9. SWITCH WAFERS ARE IDENTIFIED AS FOLLOWS:  
EXAMPLE: S1  
S2  
S3  
S4  
S5
10. FRONT PANEL NAME OF SWITCH WITH THE S1 SWITCH VIEW FROM THE F PANEL.  
S2 BAND SWITCH  
S3 MODE SWITCH
11. ARROW ( ) INDICATES CLOCKWISE ROTATION (VIEWED FROM KNOB END).
12. # INDICATES ACCESSORY.
13. # INDICATES A TIE-PIN PROVIDED BETWEEN THE FRONT AND REAR PANELS.
14. THE VOLTAGE AT TEST POINT SET TO -2.7 VOLTS. AFTER VOLTAGE CAN BE -1.5 TO -2.7 VOLTS.

-IF CIRCUIT BOARD-

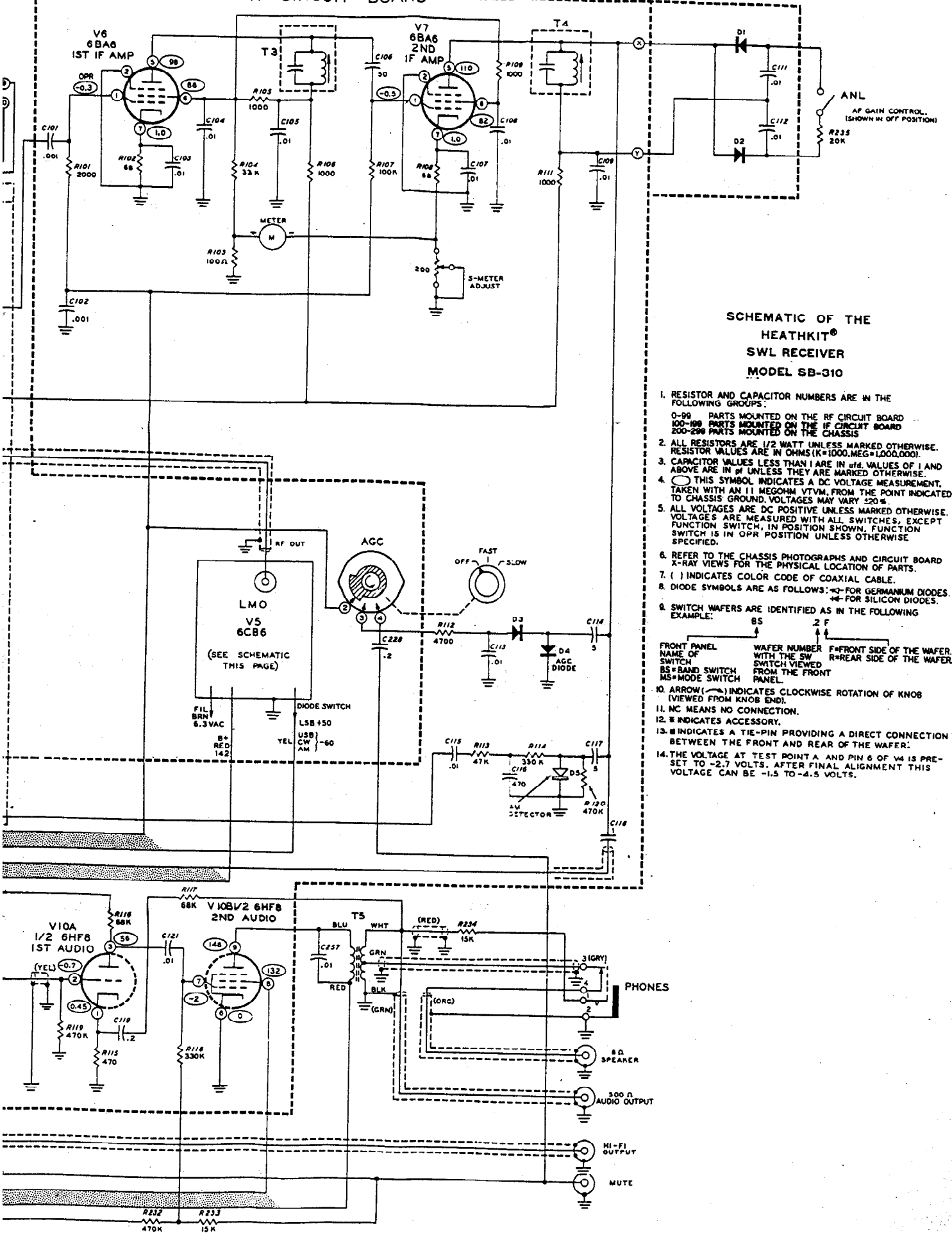

**SCHEMATIC OF THE  
HEATHKIT®  
SWL RECEIVER  
MODEL SB-310**

1. RESISTOR AND CAPACITOR NUMBERS ARE IN THE FOLLOWING GROUPS:  
 0-99 PARTS MOUNTED ON THE RF CIRCUIT BOARD  
 100-199 PARTS MOUNTED ON THE IF CIRCUIT BOARD  
 200-299 PARTS MOUNTED ON THE CHASSIS
2. ALL RESISTORS ARE 1/2 WATT UNLESS MARKED OTHERWISE. RESISTOR VALUES ARE IN OHMS (K=1000, MEG=1,000,000).
3. CAPACITOR VALUES LESS THAN 1 ARE IN  $\mu\text{F}$ . VALUES OF 1 AND ABOVE ARE IN  $\mu\text{F}$  UNLESS THEY ARE MARKED OTHERWISE.
4. ○ THIS SYMBOL INDICATES A DC VOLTAGE MEASUREMENT, TAKEN WITH AN 11 MEGOHM VTVM, FROM THE POINT INDICATED TO CHASSIS GROUND. VOLTAGES MAY VARY  $\pm 20\%$ .
5. ALL VOLTAGES ARE DC POSITIVE UNLESS MARKED OTHERWISE. VOLTAGES ARE MEASURED WITH ALL SWITCHES, EXCEPT FUNCTION SWITCH, IN POSITION SHOWN. FUNCTION SWITCH IS IN OPR POSITION UNLESS OTHERWISE SPECIFIED.
6. REFER TO THE CHASSIS PHOTOGRAPHS AND CIRCUIT BOARD X-RAY VIEWS FOR THE PHYSICAL LOCATION OF PARTS.
7. ( ) INDICATES COLOR CODE OF COAXIAL CABLE.
8. DIODE SYMBOLS ARE AS FOLLOWS:  $\triangleleft$  FOR GERMANIUM DIODES,  $\triangleleft$  FOR SILICON DIODES.
9. SWITCH WAFERS ARE IDENTIFIED AS IN THE FOLLOWING EXAMPLE:  
 FRONT PANEL NAME OF SWITCH: BS = BAND SWITCH, MS = MODE SWITCH  
 WAFER NUMBER: 2 F  
 F = FRONT SIDE OF THE WAFER, R = REAR SIDE OF THE WAFER
10. ARROW (↻) INDICATES CLOCKWISE ROTATION OF KNOB (VIEWED FROM KNOB END).
11. NC MEANS NO CONNECTION.
12. \* INDICATES ACCESSORY.
13. ■ INDICATES A TIE-PIN PROVIDING A DIRECT CONNECTION BETWEEN THE FRONT AND REAR OF THE WAFER.
14. THE VOLTAGE AT TEST POINT A AND PIN 6 OF V6 IS PRE-SET TO -2.7 VOLTS. AFTER FINAL ALIGNMENT THIS VOLTAGE CAN BE -1.5 TO -4.5 VOLTS.