

TABLE OF CONTENTS

INTRODUCTION			
The Manual	3	ALIGNMENT	111
TRANSVERTER PACKAGING	4	Receiver Alignment	112
CIRCUIT BOARD ASSEMBLY		Transmitter Alignment	114
Circuit Board Parts List	5	FINAL ASSEMBLY	119
The IF System	7	OPERATION	
Step-By-Step Assembly	7	Control Functions	121
CHASSIS ASSEMBLY		General Information	122
Chassis Parts List	14	Reading The Meter	122
Step-By-Step Assembly	18	Tune-Up Procedure	123
Chassis Parts Mounting	18	IN CASE OF DIFFICULTY	
Driver And Final Assembly	23	General	125
Top Chassis Assembly	32	Troubleshooting Chart	126
Antenna Relay Enclosure	42	Receiver Circuit Board	
Wiring Harness	45	Voltage Chart	129
Alternate Line Voltage Wiring	50	Receiver Circuit Board	
Chassis Component Wiring	50	Resistance Chart	130
Final Chassis Bottom Wiring	54	Oscillator Circuit Board	
Top Chassis Wiring	59	Voltage Chart	130
Crystal Calibrator Assembly	62	Oscillator Circuit Board	
Front Panel Assembly	66	Resistance Chart	131
Auxiliary Equipment Preparation	70	SPECIFICATIONS	133
KNOB AND TUBE INSTALLATION	78	CIRCUIT DESCRIPTION	135
INITIAL TESTS	80	Heterodyne Oscillator	136
EQUIPMENT MODIFICATION	83	Receiver Circuits	137
SB-110 Transceiver Modifications	84	Transmitter Circuits	138
SB-101 Transceiver Modifications	90	Power Supply	142
HW-100 Transceiver Modifications	100	Switching	143
Models SB-301/401 Modifications	106	CIRCUIT BOARD X-RAY VIEWS	145
Mobile Mount Modifications	110	CHASSIS PHOTOGRAPHS	146
		REPLACEMENT PARTS PRICE LIST	149
		SCHEMATIC (fold-out from page)	153

The Heathkit Model SB-500 2-Meter Transverter provides you with SSB or CW operation on the 2-meter amateur band by using your lower frequency Heath amateur station equipment as a tunable 6-meter or 10-meter IF system. This lower frequency equipment may be composed of Heath Transceivers, Transmitters and Receivers of the SB line, or the HW-100 Transceiver. In the transmitting mode, the Transverter has an output of approximately 50 watts to the antenna. In the receiving mode, the sensitivity is better than 10 dB signal-plus-noise to noise ratio for $0.2 \mu V$ of signal. The Transverter is designed for use with an antenna of 50 ohms input impedance, but in any case the standing wave ratio should not exceed 2:1.

Plate voltage for the output tubes of the Transverter is supplied from the driving unit. All other voltages are supplied from an internal power supply which operates from either a 120

volt or a 240 volt, 50/60 Hz, AC power source.

A manually operated function switch (OFF-ON) on the front panel places the Transverter into operation or permits the lower frequency equipment to operate straight through to an amplifier or antenna. Relays controlled by the driving unit automatically switch the Transverter between transmit and receive modes. ALC voltage is furnished from the Transverter to the driving unit to help avoid flat-topping and spurious signals.

At the turn of a switch, your Transverter gives you the ability to operate on two meters with a good husky signal, using your own familiar HF gear, and with the ultimate in convenience. After the installation is completed, there are no connecting cables or antennas to change back and forth - just use the ON-OFF switch on the front panel to switch between the Transverter and your other gear.

THE MANUAL

Each assembly section of this Manual gives you an illustrated list of the parts furnished for that section, and gives you detailed, illustrated, assembly instructions. The assembly sections are followed by testing and alignment instructions, details on how to install the Transverter and full operating instructions. In case problems occur, there is an "In Case of Difficulty" section, coupled with a Troubleshooting Chart, Chassis Photographs, X-Ray Views of com-

ponents mounted on circuit boards, and a Schematic Diagram. This detailed Manual, and the latest engineering designs, combine to enhance the world-wide reputation for excellence enjoyed by Heath Company products.

Read the "Kit Builders Guide" for complete information on unpacking, parts identification, tools, wiring, soldering, and step-by-step assembly procedures.

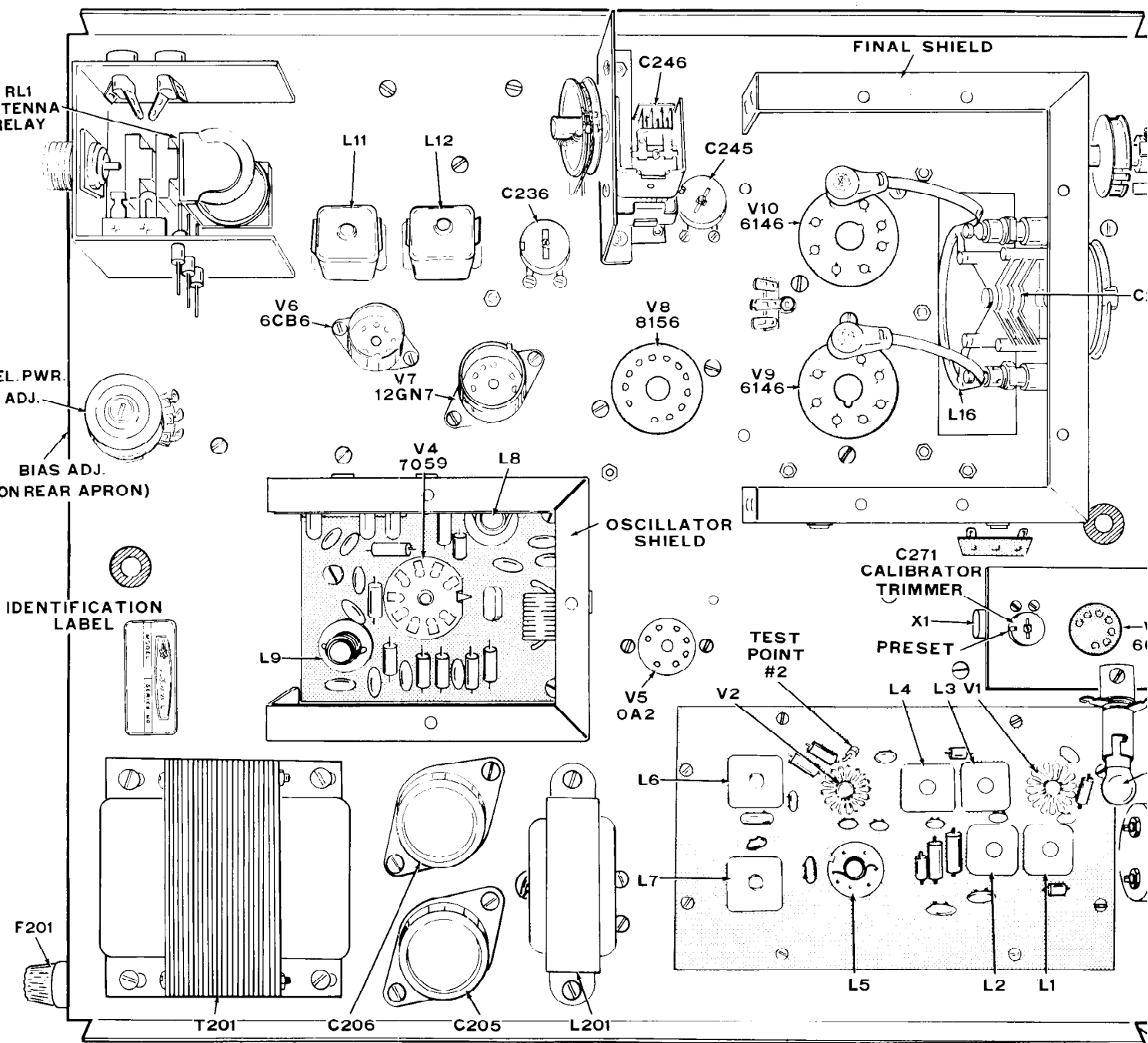

FIGURE 1-1

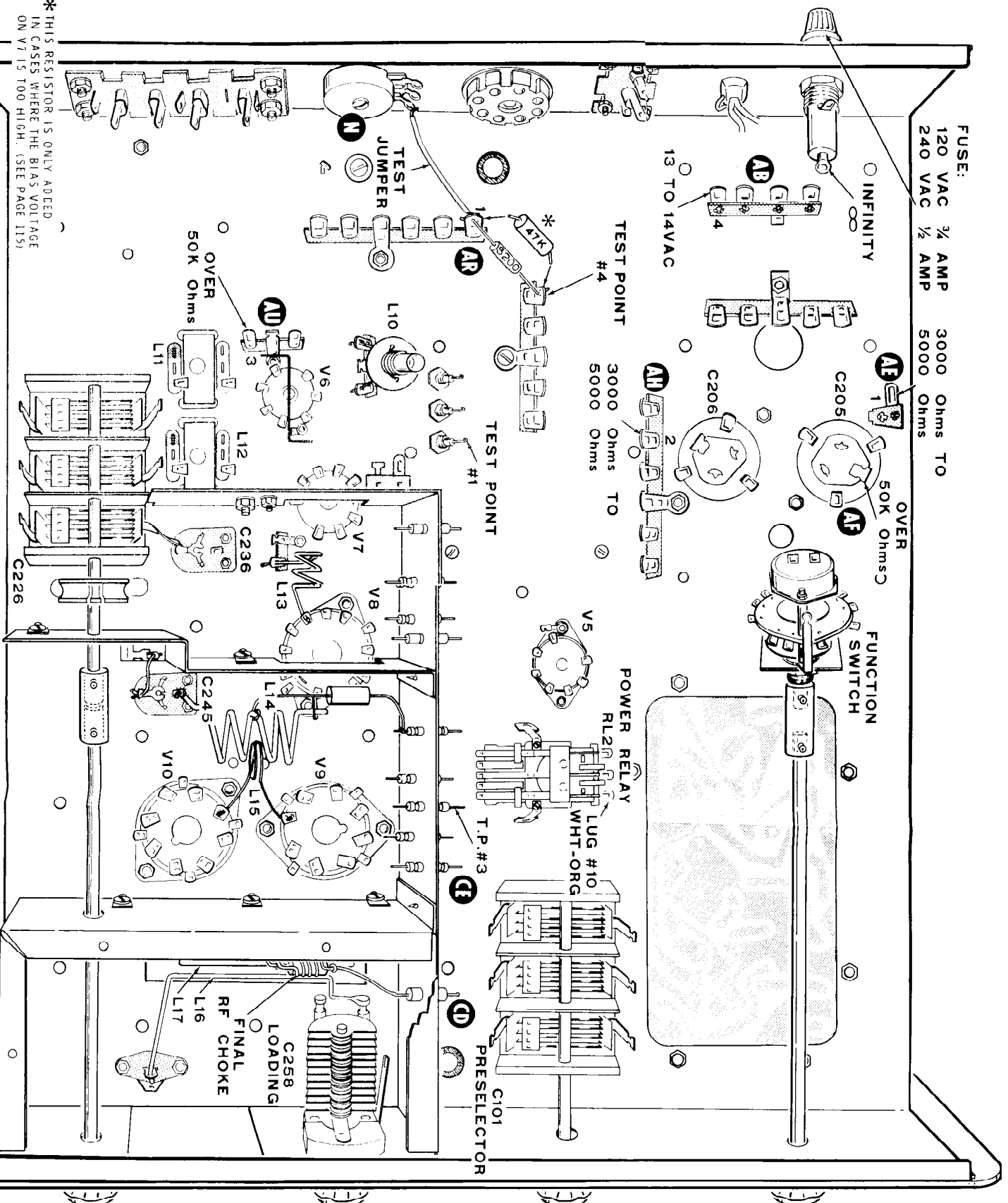
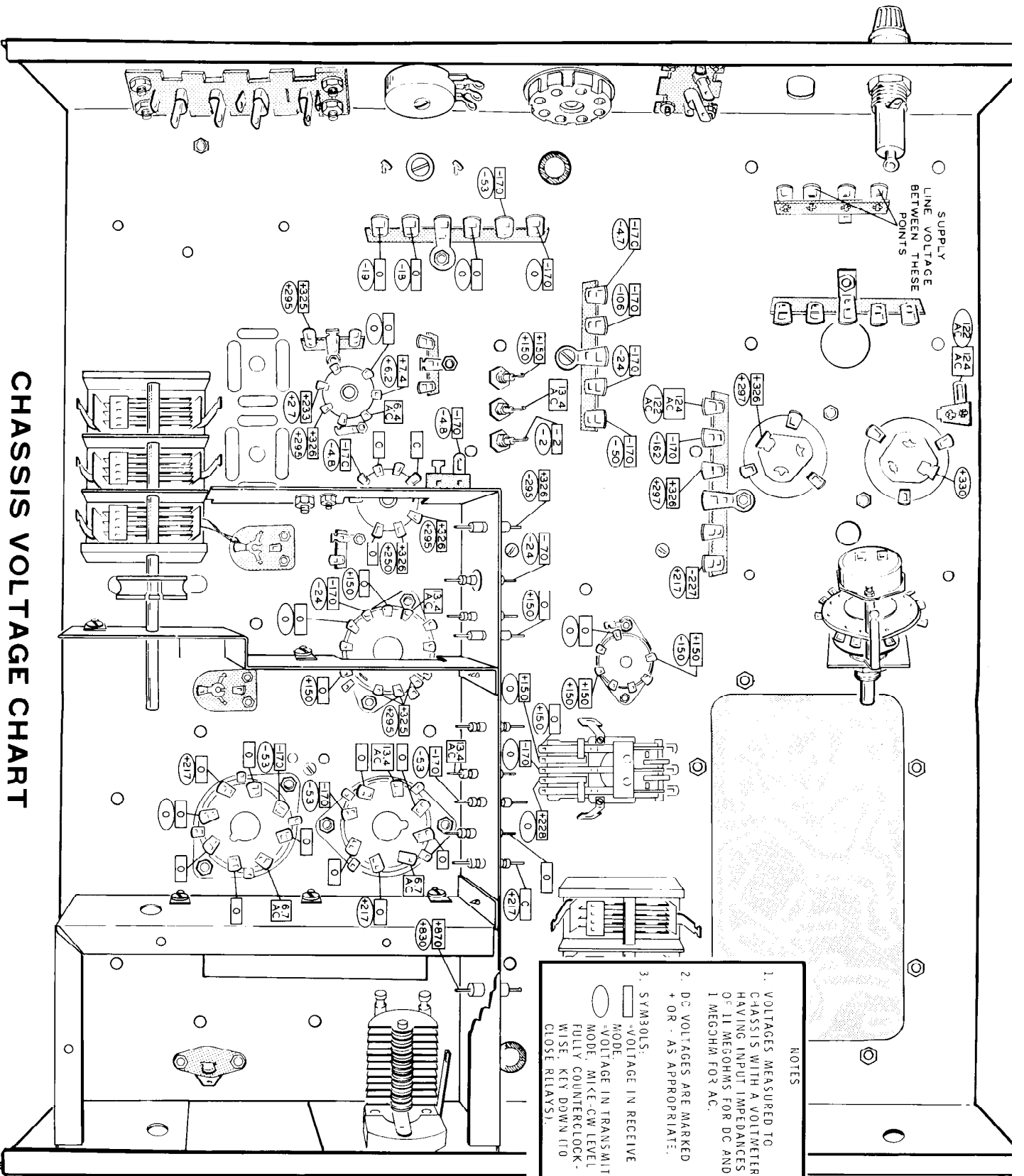

Figure 1-2

FIGURE 1-2



SUPPLY
LINE VOLTAGE
BETWEEN THESE
POINTS

NOTES

1. VOLTAGES MEASURED TO CHASSIS WITH A VOLTMMETER HAVING INPUT IMPEDANCES OF 11 MEGOHMS FOR DC AND 1 MEGOHM FOR AC.
2. DC VOLTAGES ARE MARKED + OR - AS APPROPRIATE.
3. SYMBOLS:
 — VOLTAGE IN RECEIVE MODE
 ○ VOLTAGE IN TRANSMIT MODE. MIKE-CW LEVEL FULLY COUNTERCLOCK - WISE. KEY DOWN (TO CLOSE RELAYS).

CHASSIS VOLTAGE CHART

FIGURE 11-5

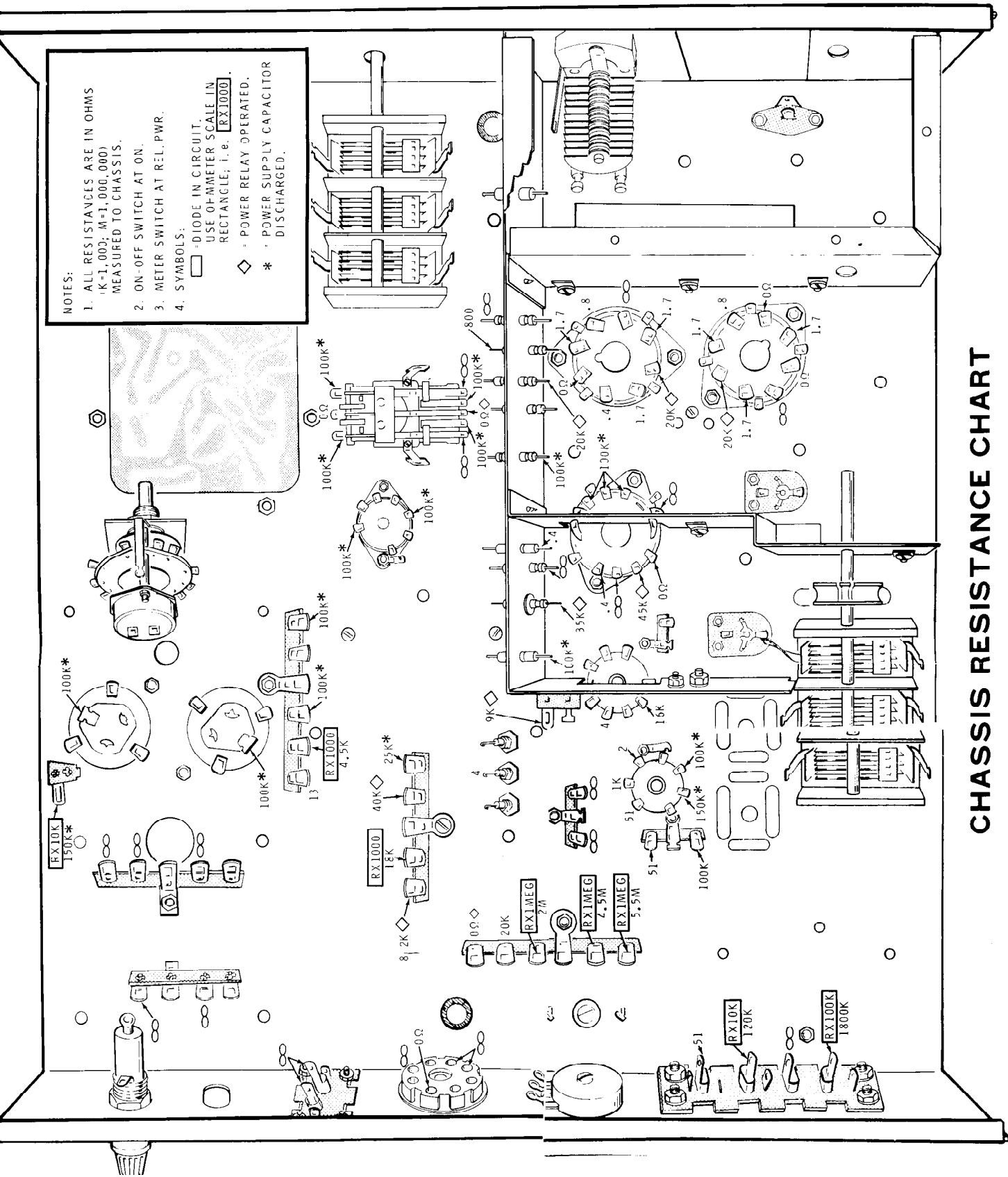

CHASSIS RESISTANCE CHART

FIGURE 11-6

to the grid of

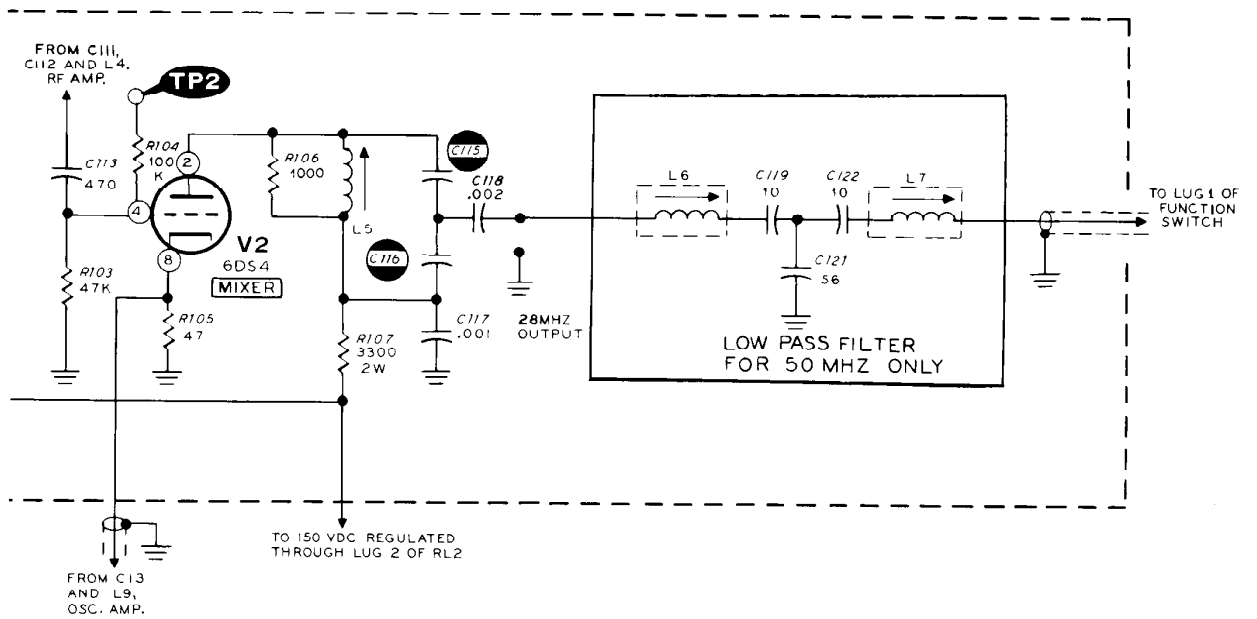

FIGURE 12-4

GRID OF
VER, V8

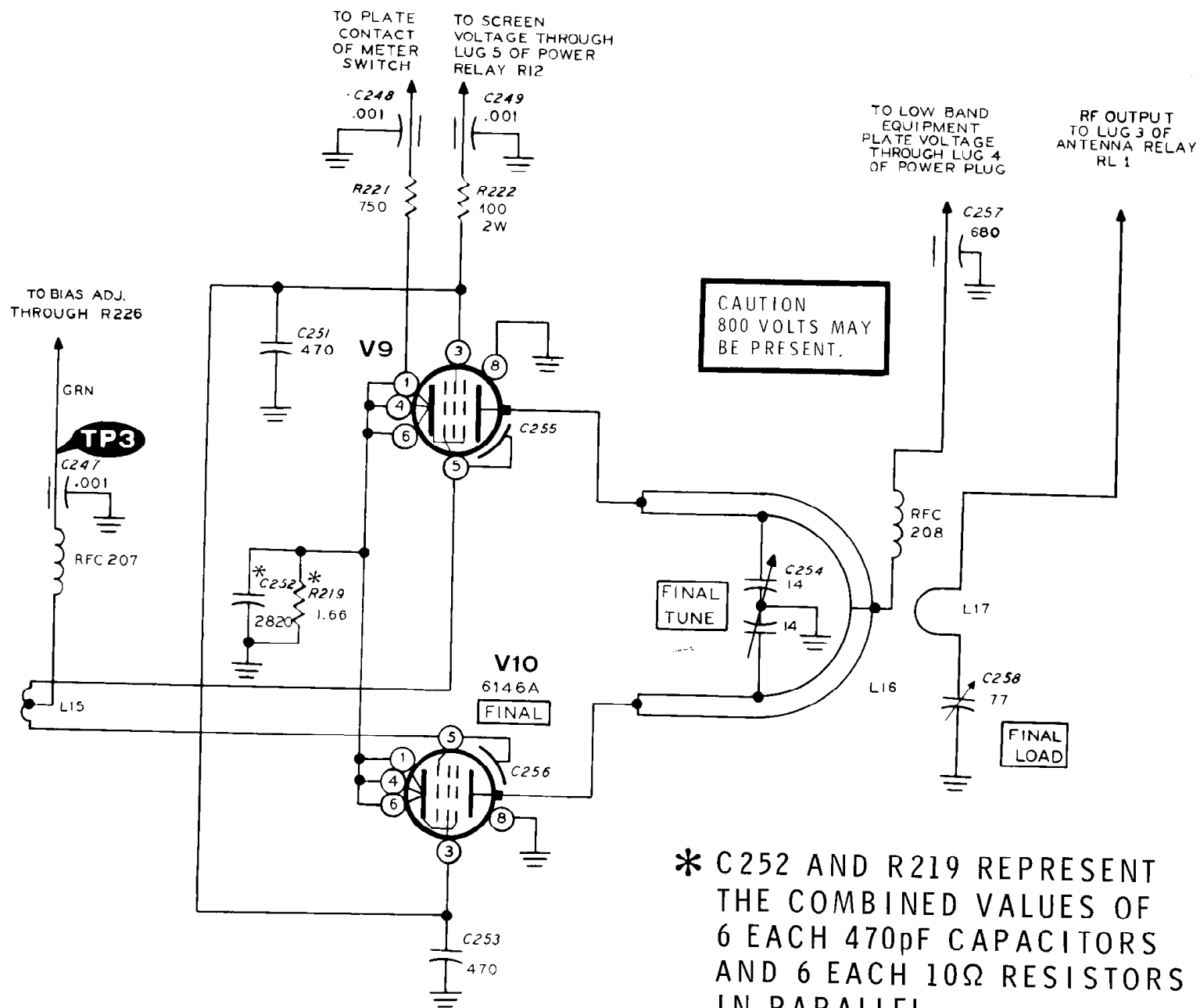
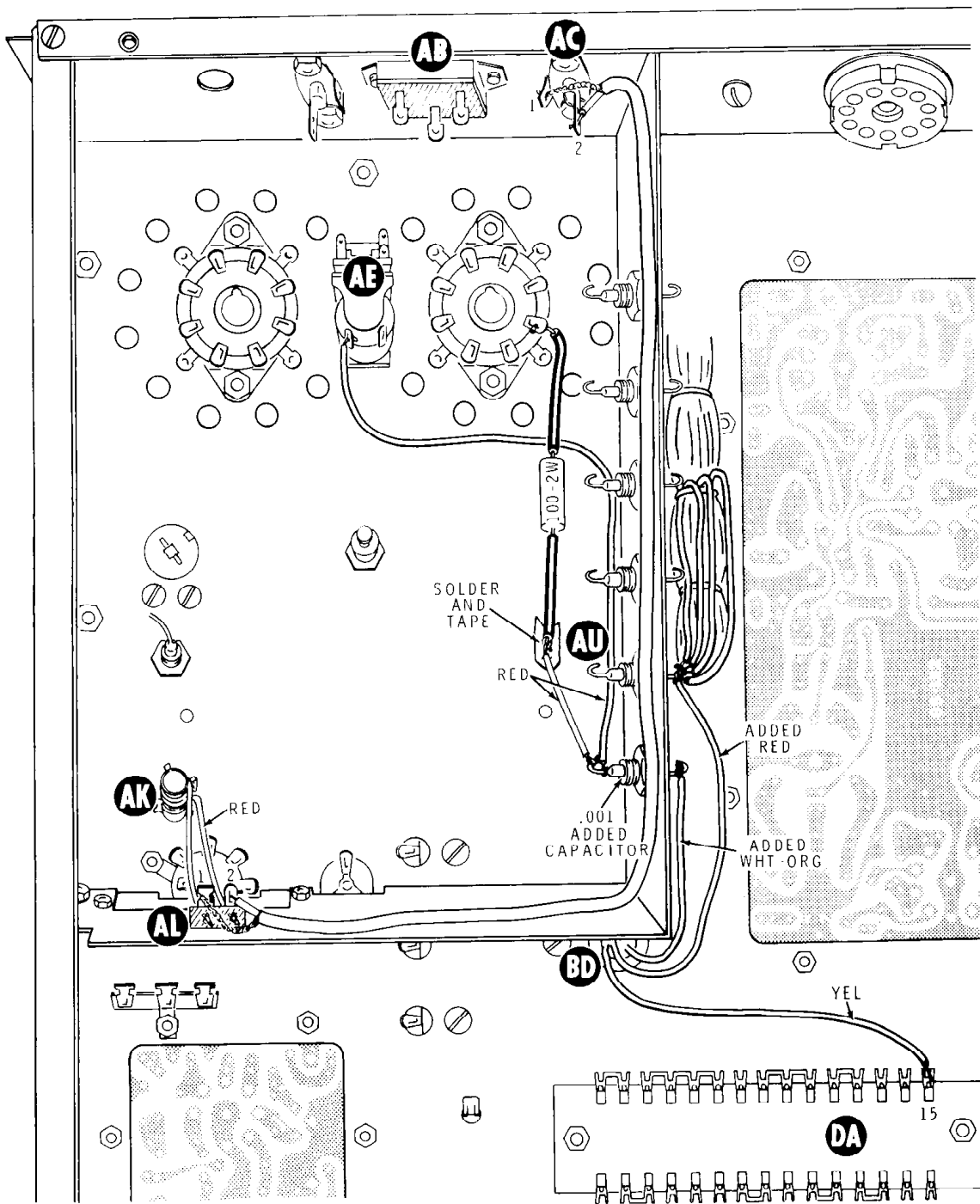
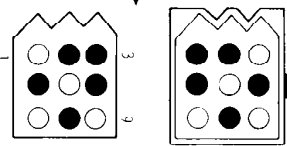

FIGURE 12-9



PICTORIAL 3-3

1	
2	GND
3	SCREEN - DC
4	-800 VDC
5	
6	AGC
7	
8	FINAL SCREENS
9	



HW-100 TRANSCEIVER

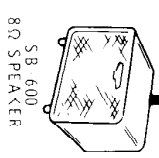
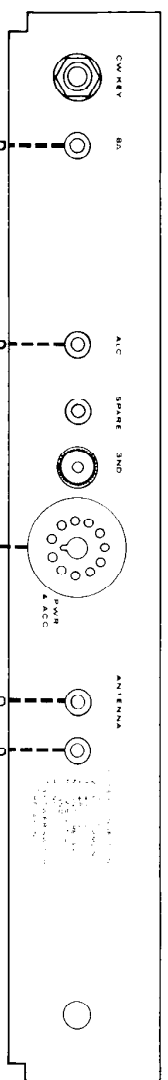

HP-23A POWER SUPPLY

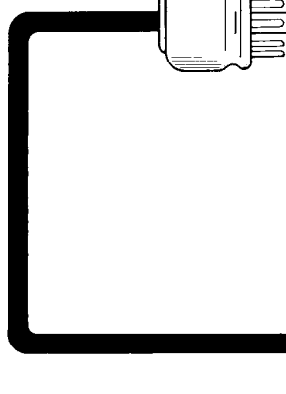
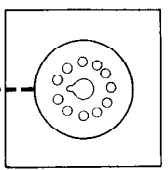

CENTER CONDUCTOR TO LUG 11
SHIELD TO LUG 5

1	BIAS
2	GND
3	-300 VDC
4	+800 VDC
5	RELAY SHIELD
6	12 VAC
7	GND. BIAS. B
8	N.C.
9	SWITCH
10	SWITCH
11	RELAY

10 2-METER
ANTENNA

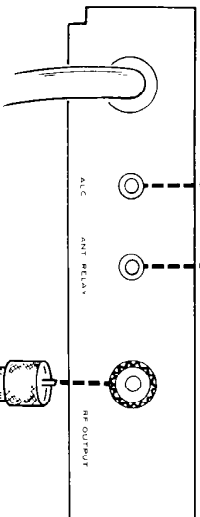
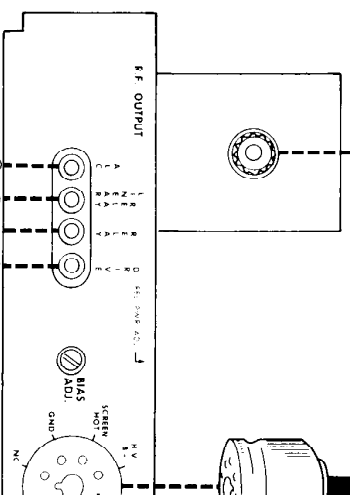

RG-174

RG-58

RG-58

RG-174

RG-174

RG-174

SB-20C

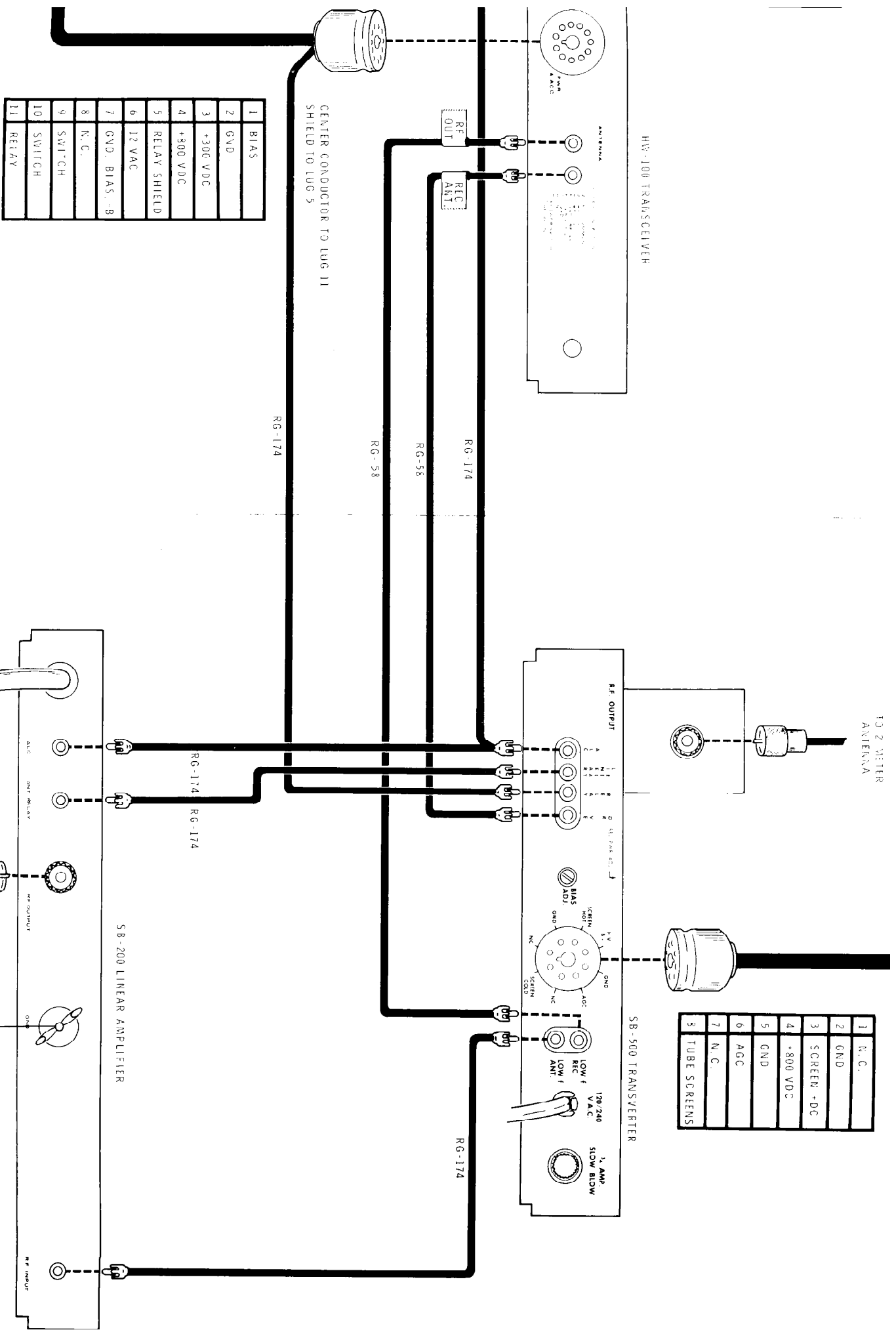

1	BIAS
2	GND
3	+300 VDC
4	+800 VDC
5	RELAY SHIELD
6	12 VAC
7	GND. BIAS. 8
8	N.C.
9	SWT-CH
10	SWITCH
11	RELAY

1	N.C.
2	GND
3	SCREEN + DC
4	+800 VDC
5	GND
6	AGC
7	N.C.
8	TUBE SCREENS

FIGURE 6-3

TO LOW FREQUENCY

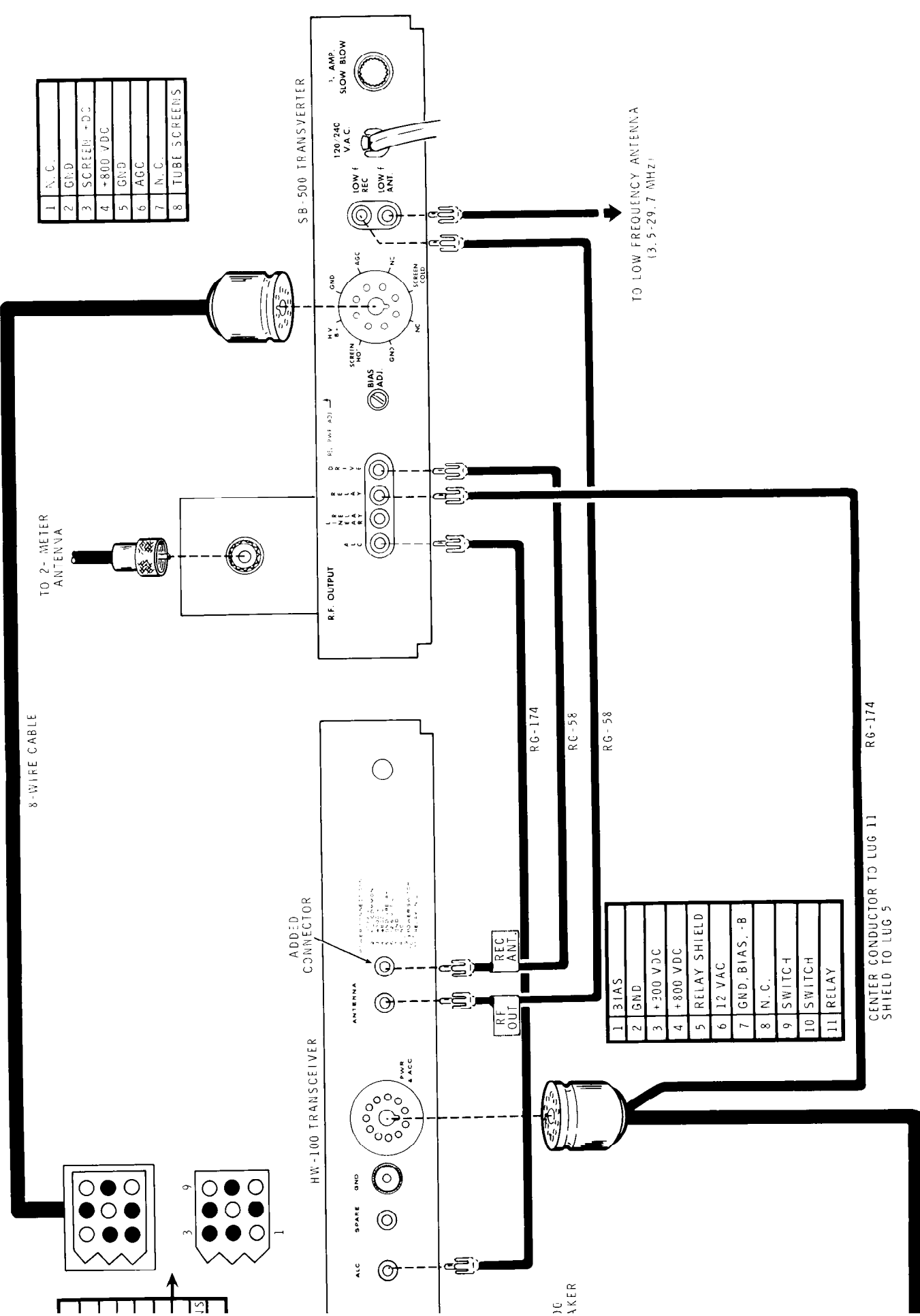

1	N. C.
2	GND
3	SCREEN +DC
4	+800 VDC
5	GND
6	AGC
7	N. C.
8	TUBE SCREENS

1	BIAS
2	GND
3	+300 VDC
4	+800 VDC
5	RELAY SHIELD
6	12 VAC
7	GND, BIAS. -B
8	N. C.
9	SWITCH
10	SWITCH
11	RELAY

TO LOW FREQUENCY ANTENNA
(3.5-29.7 MHz)

CENTER CONDUCTOR TO LUG 11
SHIELD TO LUG 5

FIGURE 6-2

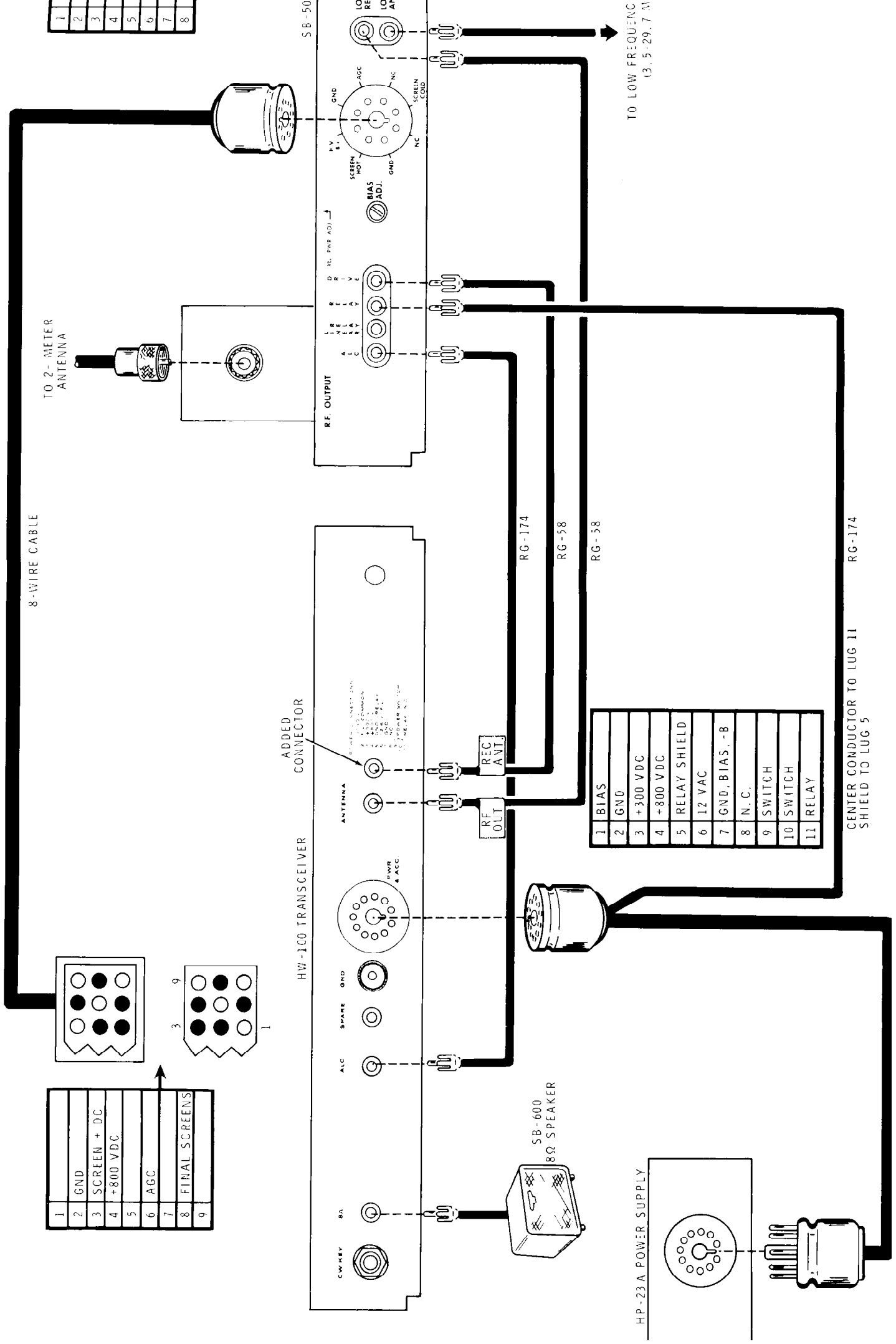

1	
2	GND
3	SCREEN + DC
4	+800 VDC
5	
6	AGC
7	
8	FINAL SCREENS
9	

1	BIAS
2	GND
3	+300 VDC
4	+800 VDC
5	RELAY SHIELD
6	12 VAC
7	GND, BIAS, -B
8	N. C.
9	SWITCH
10	SWITCH
11	RELAY

CENTER CONDUCTOR TO LUG 11
SHIELD TO LUG 5

HP-23A POWER SUPPLY

SB-600
8Ω SPEAKER

HW-100 TRANSCEIVER

ADDED CONNECTOR

SB-50

TO LOW FREQUENCY
(3.5-29.7 MHz)

TO 2-METER
ANTENNA

8-WIRE CABLE

RF OUTPUT

RG-174

RG-58

RG-58

RG-174

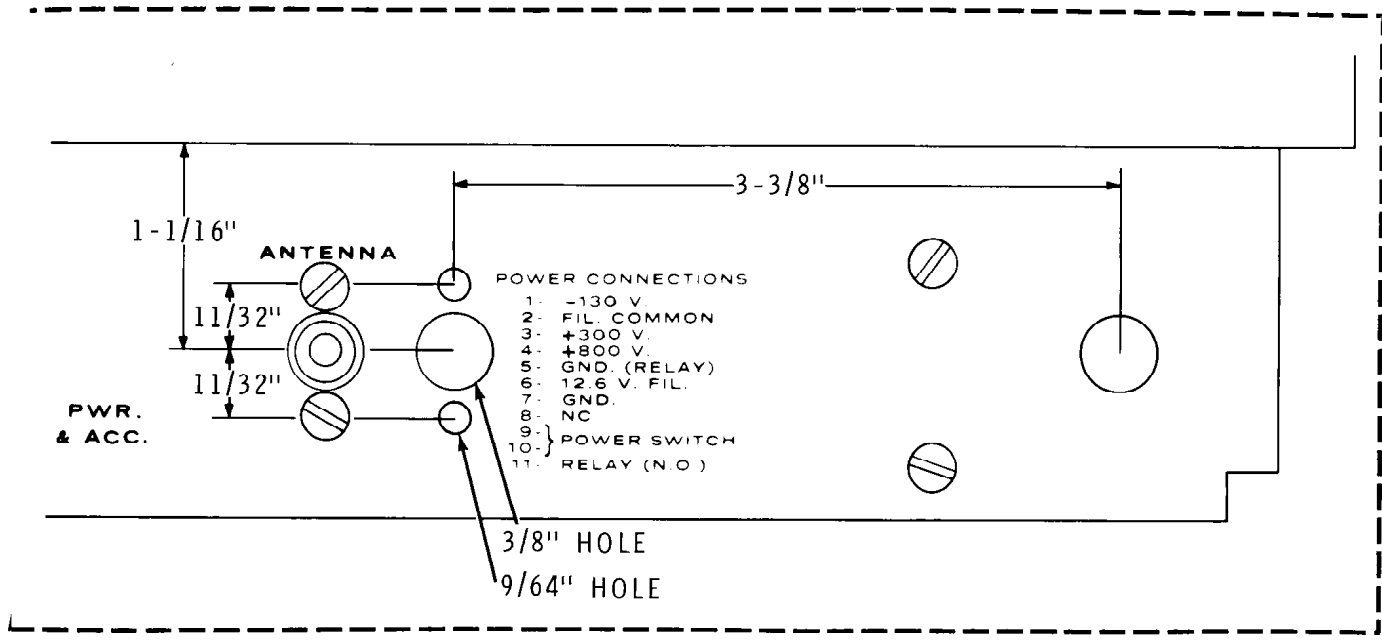

Detail 6-3A

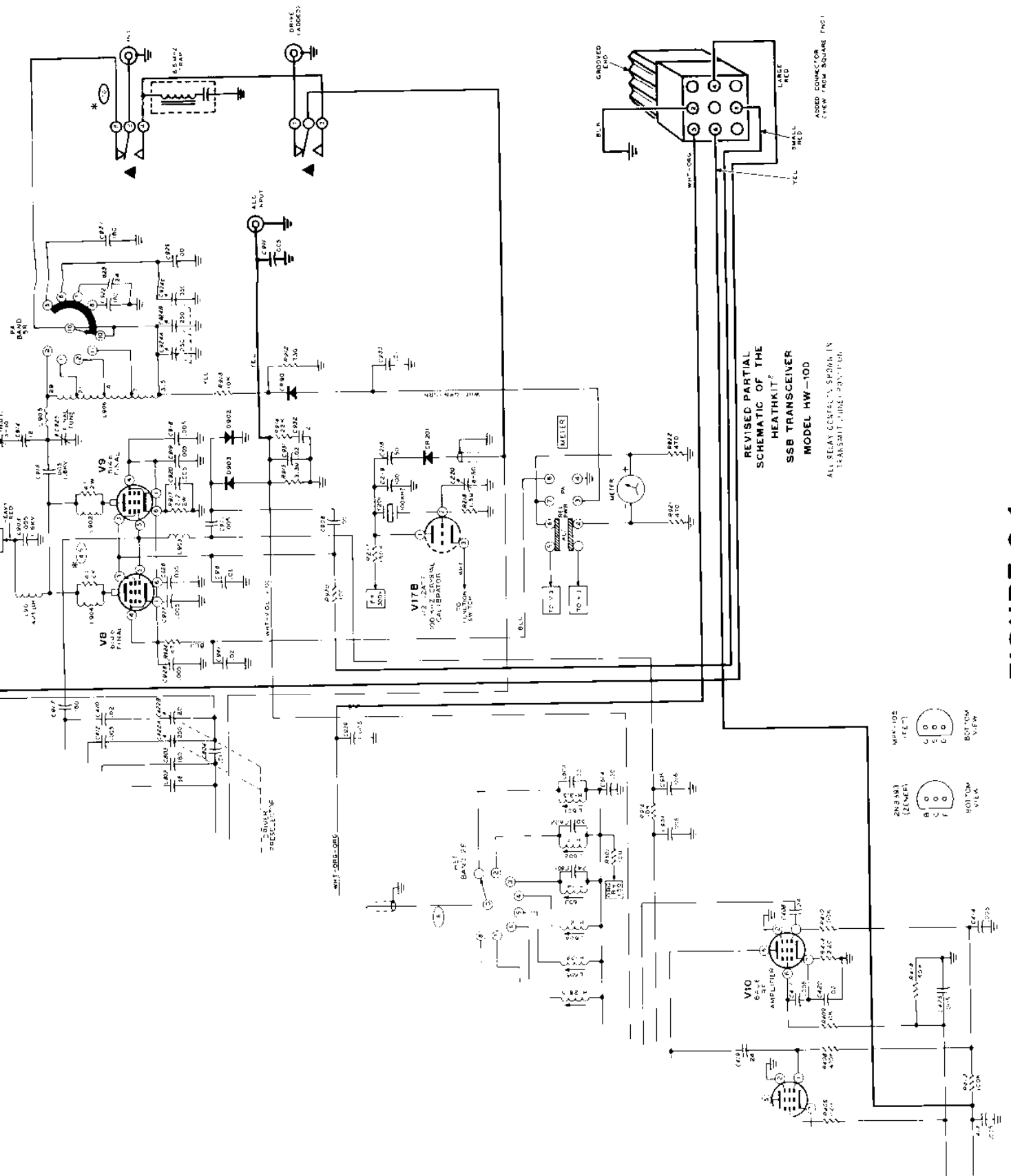
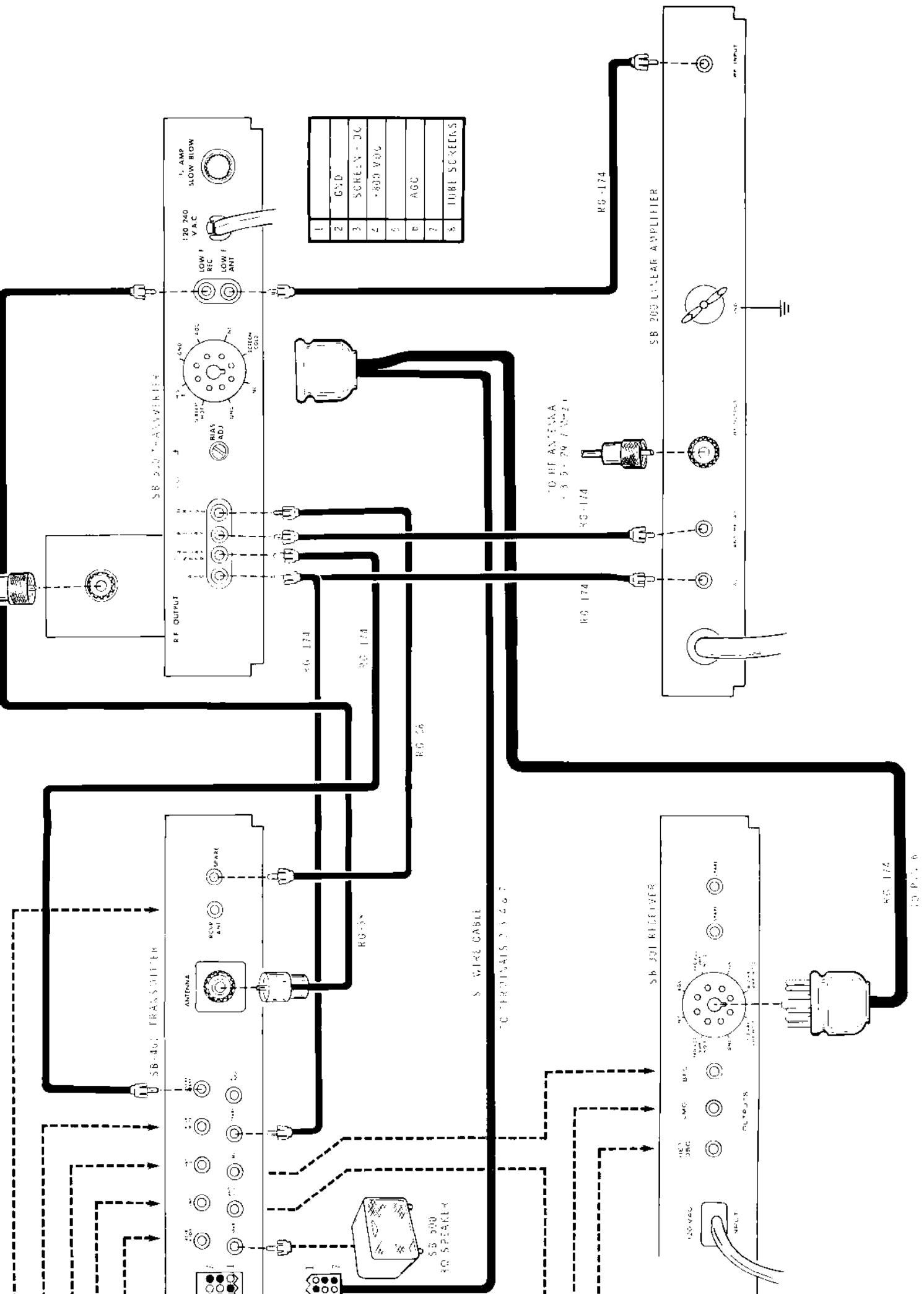

FIGURE 6-1



1	
2	6YD
3	SCREEN - DC
4	+800 VDC
5	
6	AGC
7	
8	TUBE SCREENS

5 WIRE CABLE

TO HEAVENLY 33-267

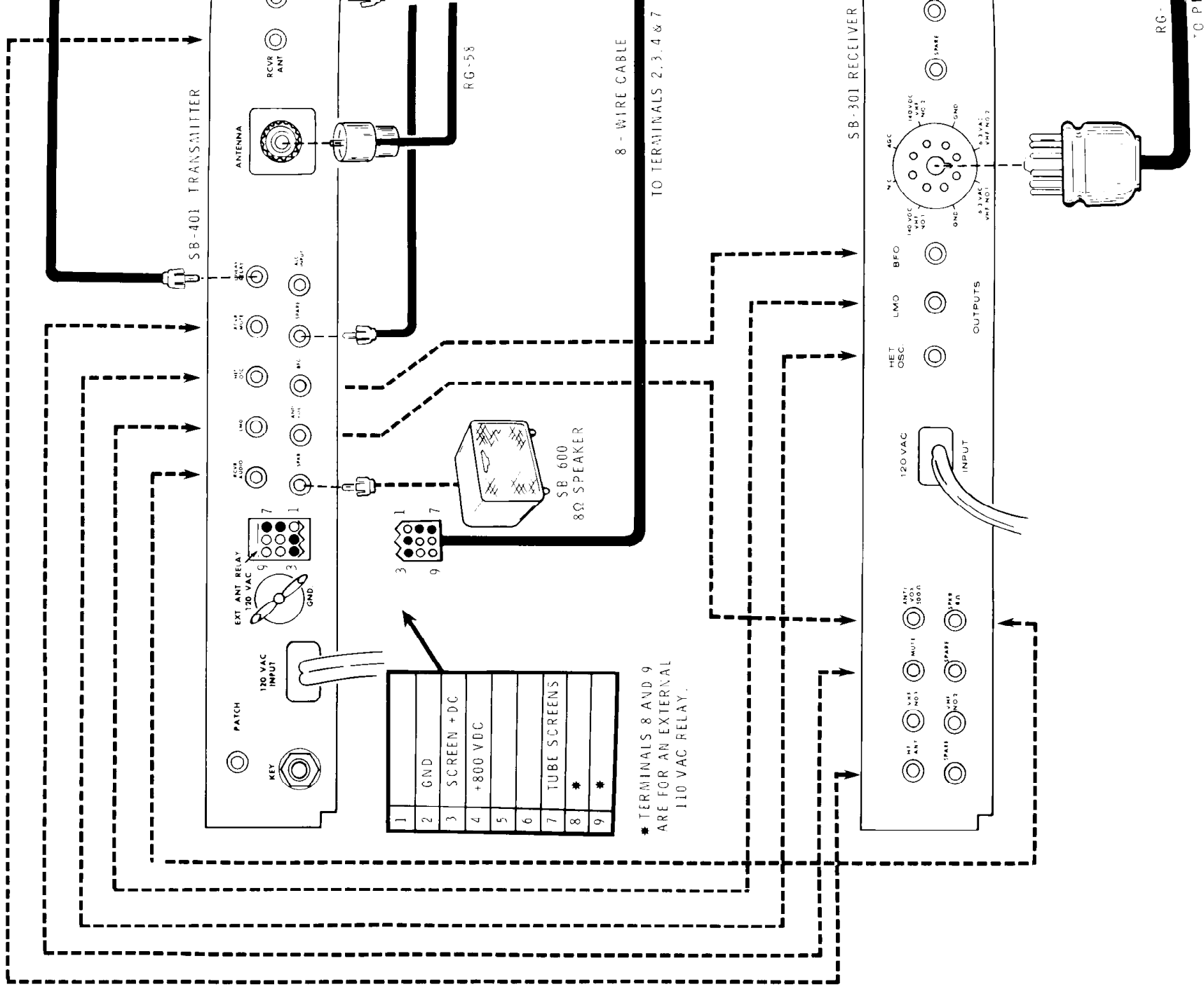

PATCH

KEY

EXT ANT RELAY
120 VAC

GND

RCVR
AUDIO

120 VAC

1

3

7

9

1

7

9

1

7

9

1

7

9

1

7

9

1

7

9

1

7

9

1

7

9

1

7

9

1

7

9

1

7

9

1

7

9

1	
2	GND
3	SCREEN + DC
4	+800 VDC
5	
6	
7	TUBE SCREENS
8	*
9	*

* TERMINALS 8 AND 9
ARE FOR AN EXTERNAL
110 VAC RELAY.

SB 600
8Ω SPEAKER

120 VAC
INPUT

OUTPUTS

NET
OSC

LMO

BFO

VE

140 VDC
VHT NO1

140 VDC
VHT NO2

140 VDC
VHT NO3

GND

120 VAC
VHT NO1

120 VAC
VHT NO2

120 VAC
VHT NO3

GND

RG

TO P

AUXILIARY EQUIPMENT PREPARATION

INTERCONNECTING CABLES

8- Wire Cable

A cable socket, which is installed on the 8-wire cable in the following steps, will connect to the 8-pin plug on the back of the Transverter. The bypass capacitors that are installed on this socket in the first five steps are necessary to keep undesired frequencies out of the Low Band Equipment. To install all of these capacitors within the cable socket, you must keep the capacitor leads as short as physically possible.

Refer to Pictorial 2-14 for the following steps.

Note that each lug on the socket may have two holes or slots. The holes closest to the socket body are called "lower" holes, and those closest to the ends of the lugs are called "upper" holes. When directed to solder wires connected to lower holes, be very careful to keep solder out of the upper holes, to which cable wires will be connected later. If the lug has a slot instead of two holes, position the component leads close to the socket.

The five bypass capacitors are shown in the three parts of Detail 2-14A for greater clarity. Previously installed capacitors are not shown in Parts B and C. Small headings (Part A, Part B, etc.) above the steps will tell which part to refer to in the Detail.

Connect $.001 \mu\text{F}$ disc capacitors between the lower holes of the 8-lug socket as directed in the following four steps.

ARROW DENOTES KEYWAY LOCATION

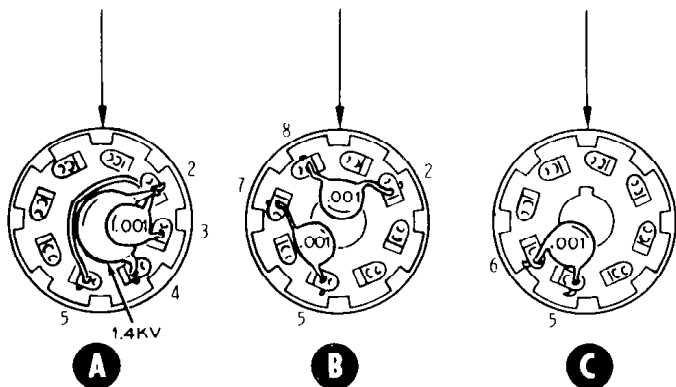

Detail 2-14A

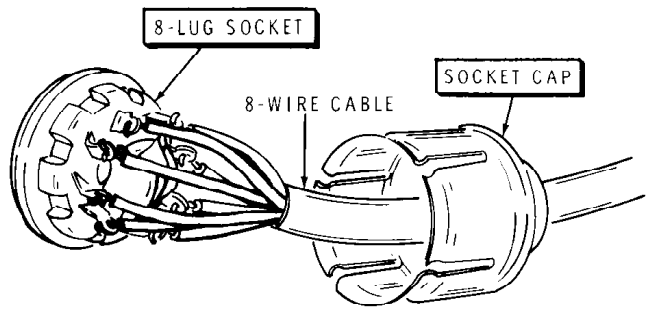

PICTORIAL 2-14

PART A

- () 1.4 kV, from lug 2 (NS) to lug 4 (S-1).
- () One lead to lug 3 (S-1). Other lead through lug 2 (NS) to lug 5 (NS).

PART B

- () From lug 2 (S-4) to lug 8 (S-1).
- () From lug 5 (S-2) to lug 7 (S-1).

PART C

Connect a $.001 \mu\text{F}$ disc capacitor between the upper holes of the 8-lug socket in the following step:

- () Lug 5 (NS) to lug 6 (NS).

Inspect the socket carefully to make sure that all leads, except those in the last step above, are soldered, and that there are no short circuits. Cut off excess leads.

SB-301/SB-401 STEPS

Perform the following group of steps if you use your Transverter with the SB-301 Receiver and SB-401 Transmitter combination. For other models of the Heath SB-series, or the HW-100, disregard this section and proceed to the "Other Models" section which follows (Page 72).

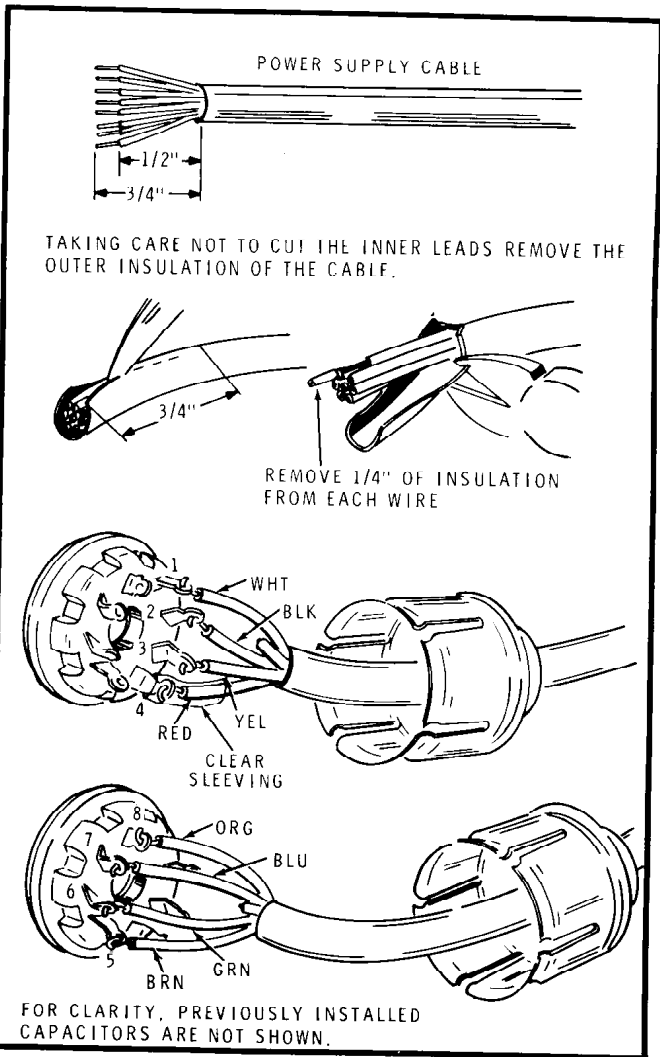

Detail 2-14B

- () Refer to Detail 2-14B and connect and solder the appropriate wires of the 8-wire cable to the upper holes of lugs 1, 2, 3, 4, 7 and 8 of the 8-lug socket. Before connecting the red wire to lug 4, slide a 1/2" length of clear sleeving over it. After the joint has cooled, slide the sleeving down over the connection.
- () Connect the brown wire of the 8-wire cable to the upper hole of lug 5 (NS), and the green wire to the upper hole of lug 6 (NS) of the 8-lug socket.
- () Slide the socket cap onto the cable from the free end.

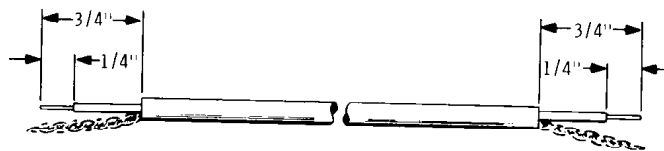

Detail 2-14C

- () 1. Refer to Detail 2-14C and prepare both ends of a length of small (RG-174/U) coaxial cable. The length of this (AGC) cable is governed by the physical location of your equipment; it must reach from the 8-pin plug on the back of the Transverter to the 8-pin converter socket on the back of the SB-301 Receiver.
- () 2. Insert one end of the prepared coaxial cable through the hole in the cap for the 8-lug socket.
- () 3. Refer to Detail 2-14D and connect the center conductor of the coaxial cable to lug 6 (S-2) and the shield wires to lug 5 (S-3) of the 8-lug cable socket.
- () 4. Snap the cap onto the cable socket.

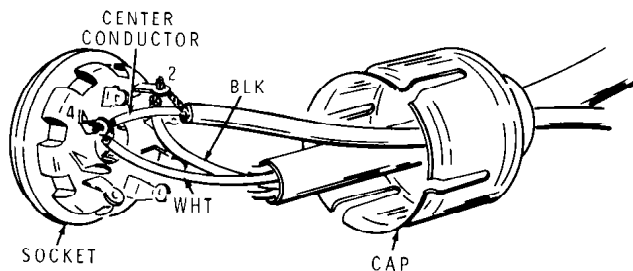

Detail 2-14D

NOTE: In the following step, connect the other end of the coaxial cable in a similar manner to the 8-pin plug (supplied with the SB-301) for the 8-pin converter socket on the back of the SB-301 Receiver.

- () 5. Connect the center conductor to lug 4 and the shield wires to lug 2. Solder both connections; then replace the cap on the cable plug.

OTHER MODELS

- (✓) Refer to Detail 2-14B and connect and solder the wires of the 8-wire cable to the upper lug holes of the 8-lug socket. Before connecting the red wire, slide a 1/2" length of clear sleeving over it. After the joint has cooled, slide the sleeving down over the connection.
- (✓) Slide the socket cap onto the cable from the free-end, and snap it onto the socket.

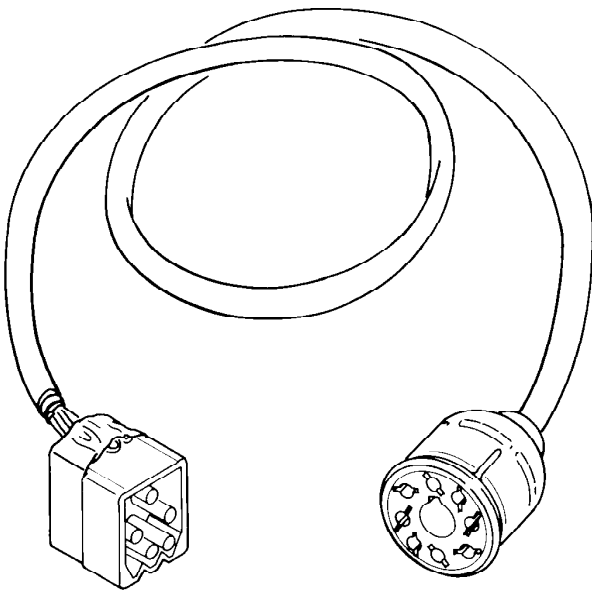

PICTORIAL 2-15

ALL MODELS

Refer to Pictorial 2-15 for the following steps.

- (✓) Refer to Detail 2-15A and prepare the free end of the 8-wire cable as shown.

- ① TAKING CARE NOT TO CUT THE INNER WIRES, REMOVE THE OUTER INSULATION OF THE CABLE.

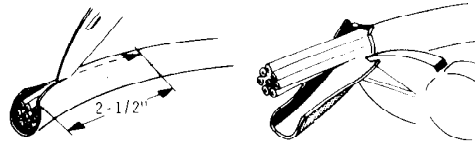

- ② CUT OFF THE WHITE AND THE BROWN WIRES AT THE END OF THE OUTER COVERING.



- ③ REMOVE 1/4" OF INSULATION FROM EACH OF THE WIRES EXCEPT THE BLUE WIRE.

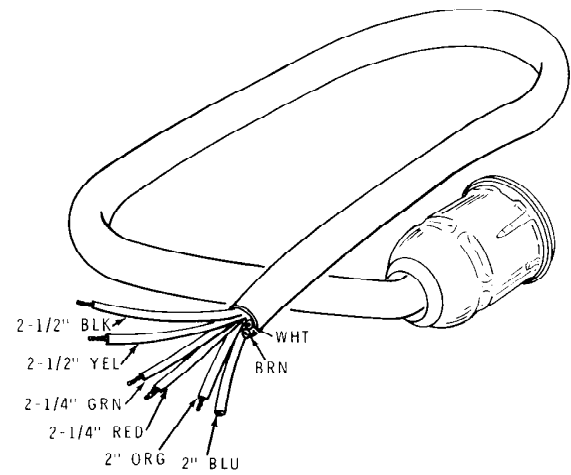

- ④ APPLY A SMALL AMOUNT OF SOLDER TO THE ENDS OF THE INNER LEADS.

Detail 2-15A

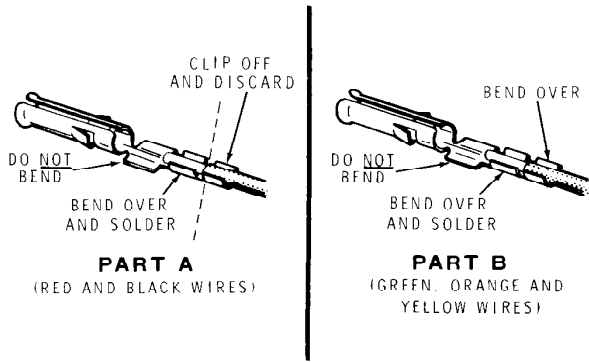

Detail 2-15B

- () Refer to Part A of Detail 2-15B and clip off the portion shown of two female terminals (#432-73). Connect one of these terminals to the red wire and one terminal to the black wire of the 8-wire cable. Solder both connections.
- () Refer to Part B of Detail 2-15B and connect female terminals to the green, orange and yellow wires of the 8-wire cable. Solder the three connections. Note that the terminal ends are not clipped off.
- () Refer to Detail 2-15C and wrap the blue wire around the remaining wires; position it close to the end of the outer covering.

NOTE: Before inserting any wire terminals into the 9-terminal connector, read the paragraph on Page 83 concerning the connectors and the use of the extractor tool furnished.

CAUTION: If you intend to use the Transverter with the SB-401 Transmitter, the orange wire from the 8-wire cable **MUST BE** inserted into hole #7 in the following step. For use with any of the **OTHER** models of Heath equipment named in this Manual, the orange wire **MUST BE** inserted into hole #8.

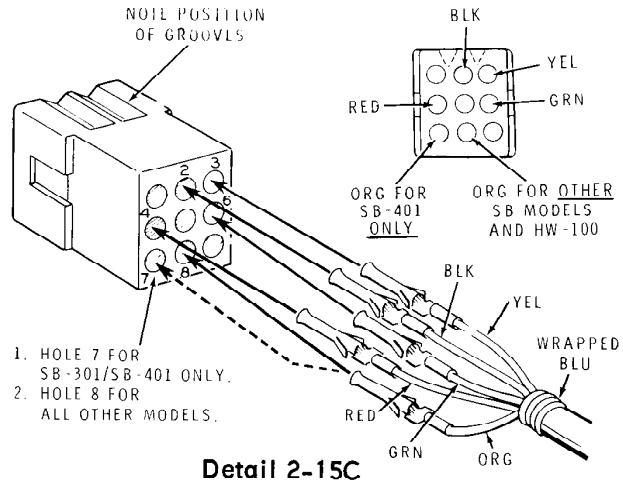

Detail 2-15C

- () Refer to Detail 2-15C and insert the terminals on the five cable wires into a 9-terminal cable connector. Be **SURE** to insert these terminals into the correct holes. Push the terminals until they snap into place.
- () Refer to Detail 2-15D and double the wires back over the rear half of the cable connector. Tape the wires tightly to the cable connector with at least two wraps of tape. This provides a strain relief for the cable wires.
- () Lay the completed cable aside for use later.

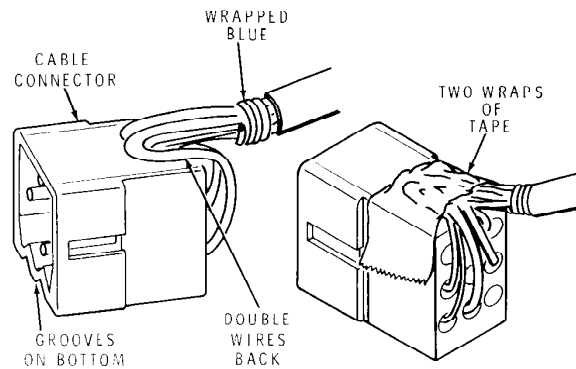

Detail 2-15D

Coaxial Cables

- () Refer to Pictorial 2-16 and prepare a 39" small coaxial cable. Install a phono plug on each end of the cable (total 2). This is the ALC cable.

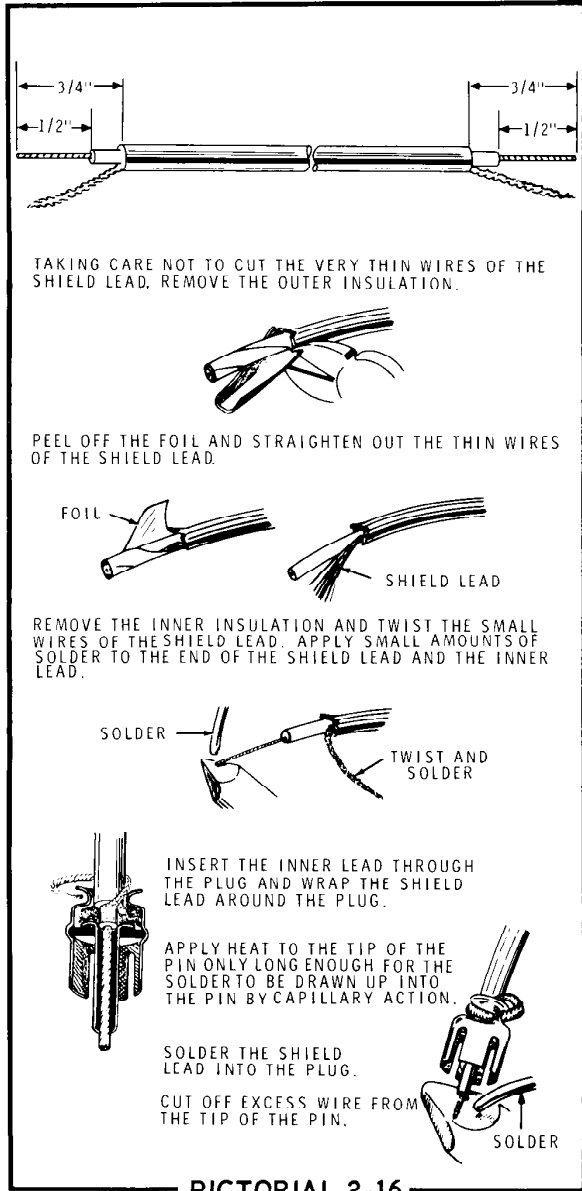

NOTE: DO NOT perform the following four steps if:

- A. You are using the Models SB-301/SB-401 as your low band equipment.
 - B. You have been using a linear amplifier with your low band equipment and already have a relay line connected to 11-lug power supply socket.
1. (/) Refer to Pictorial 2-16 and prepare a 38" length of small coaxial cable, but install a phono plug on one end only.

Refer to Pictorial 2-17 for the following steps.

2. () Remove the cap from the 11-lug power cable socket of your low-band equipment. Pass the free prepared end of the 38" coaxial cable through the small hole in the cap toward the 11-lug socket.
3. () Cut the bared center conductor of the coaxial cable to a length of 1/4". Connect the center conductor to lug 11 (S-1) and the shield wires to lug 5 (S-1) of the 11-lug socket. Make sure the shield wires do not touch neighboring wires; tape the shield wires if necessary.
4. (/) Replace the socket cap.

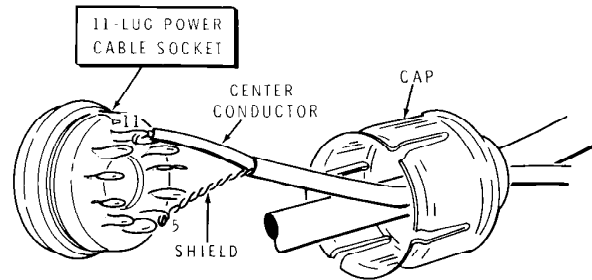

() Refer to Pictorial 2-18 and prepare the following two large coaxial cables. Install a phono plug on each end of each cable (total 4).

CABLE	LENGTH
RF OUT to LOW f REC	38"
DRIVE	39"

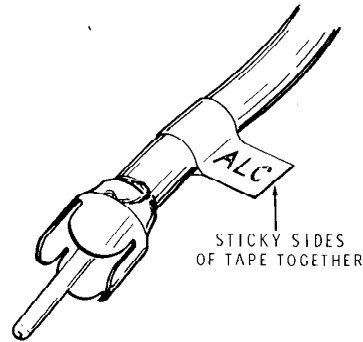

PICTORIAL 2-19

Refer to Pictorial 2-19 for the following steps.

In each of the next four steps, make two small flags from 1-1/2" lengths of masking or white adhesive tape. Then place a flag near each phono plug and mark the flags as directed with ink.

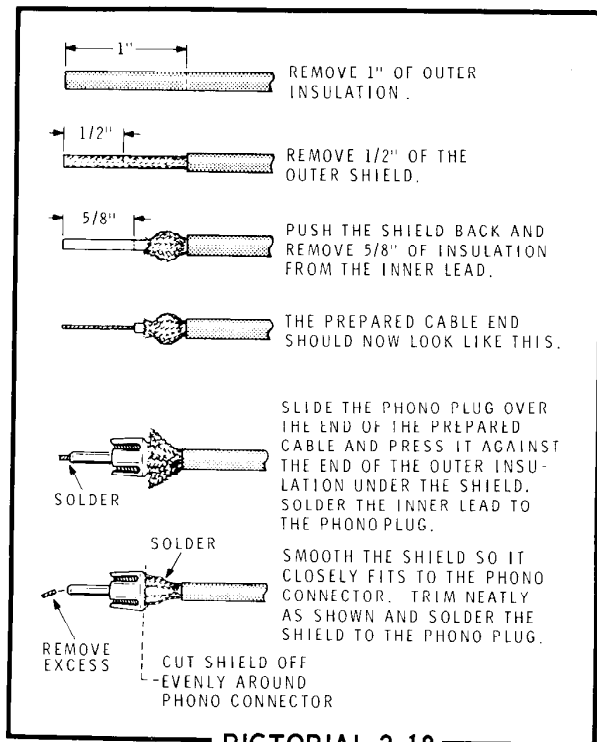

PICTORIAL 2-18

CABLE	MARK	
	ONE END	OTHER END
() 39" small (2 plugs)	ALC	ALC
() 38" small (1 plug)	RELAY (plug end)	CABLE SOCKET
() 39" large	DRIVE	REC ANT
() 38" large (2 plugs)	RF OUT	LF REC

() Lay the interconnecting cables aside for use later.

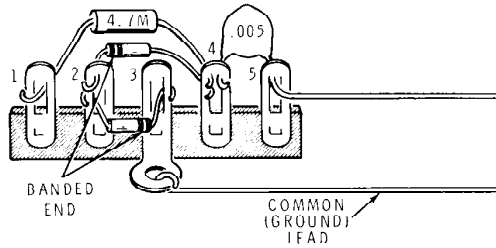

PICTORIAL 2-20

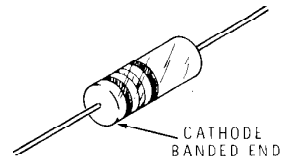

Detail 2-20B

RF DETECTOR ASSEMBLY

NOTE: If you have an RF probe rated at 75 volts, or higher, you will not need to assemble this RF Detector. Proceed directly to the "Screen Jumper Connector" section following. Use your RF probe in the remainder of this Manual instead of the RF Detector.

Refer to Pictorial 2-20 for the following steps.

The RF detector, which will be assembled in the following steps, will be used later when you align the transmitter. The schematic of the detector is shown in Detail 2-20A.

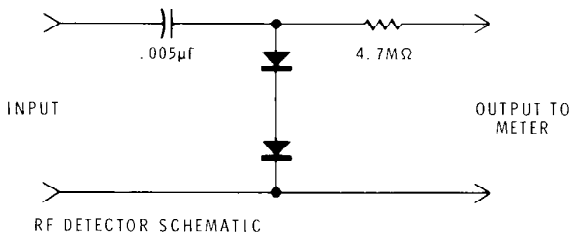

Detail 2-20A

- (✓) Connect a 4.7 MΩ (yellow-violet-green) resistor from lug 1 (S-1) to lug 4 (NS) of a 5-lug terminal strip.
- () Connect one lead of a .005 µF disc capacitor to lug 4 (NS) and pass the other lead all the way through lug 5 (S-2) of the 5-lug terminal strip. Form the free end as shown.

- () Refer to Detail 2-20B and connect the lead at the cathode (banded) end of a 1N191 diode to lug 2 (NS) and the other lead to lug 4 (S-3) of the 5-lug terminal strip.
- () Connect the lead at the banded end of a 1N191 diode to lug 3 (S-1) and the other lead to lug 2 (S-2) of the 5-lug terminal strip.
- (✓) Connect a 2-1/2" bare wire to the eye of the ground lug of the terminal strip (S-1). Form the wire so it is parallel to the capacitor lead from lug 5.

Lay the RF detector aside until it is required later.

SCREEN JUMPER CONNECTOR

When the modification of the Transverter is completed, voltage is applied through the ON-OFF switch of the Transverter to the screens of the final tubes in the low band equipment. If you wish to use the low band equipment without the Transverter, make up a jumper connector as directed below. When this connector is installed on the chassis 9-pin connector, it will complete the DC line to the final screens and allow the low band equipment to operate as before modification.

- (✓) Cut a 1-7/16" length of red hookup wire and remove 3/8" of insulation from each end,

KNOB AND TUBE INSTALLATION

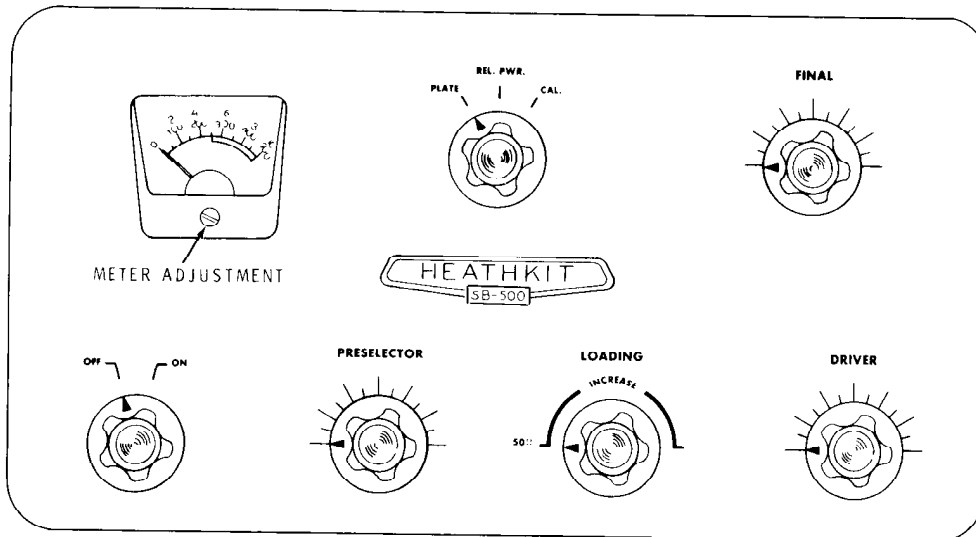

PICTORIAL 2-22

Refer to Pictorial 2-22 for the following steps.

- () While tapping the meter face gently with the tip of one finger, adjust the screw on the meter face until the pointer is directly over the zero line.
- () Refer to Detail 2-22A and start an 8-32 x 1/4" setscrew into each of the six knobs. Do not let the point of the setscrew project into the shaft hole.

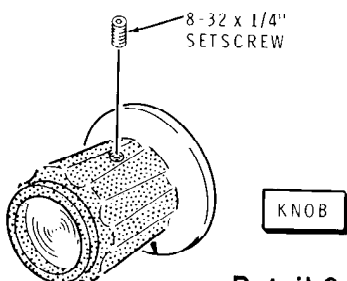

Detail 2-22A

- () Disregard the FINAL and LOADING shafts, and turn the other four shafts fully counter-clockwise.
- () Turn the LOADING shaft so the capacitor plates are fully meshed.
- () Disregard the FINAL shaft, and place a knob on each of the other five shafts. Position each knob index mark as shown in the Pictorial, and tighten the setscrew.
- () Make sure the plates of the FINAL tuning capacitor are fully meshed and that the bushing setscrew is pointing straight up. Then turn the control nut on the shaft bushing so it is snug, but not tight.

- () Temporarily install a knob on the FINAL shaft with the index mark as shown, and so that the plates of the final capacitor are fully meshed.
- () Position the rotational stop so the travel of the index mark coincides with the marks screened on the panel.
- () Remove the knob; then tighten the control nut on the shaft bushing and the long set-screw in the bushing behind the panel. Replace the knob.
- () Refer to Figure 1-1 (fold-out from Page 78) and install the tubes V3 through V10 in their sockets and the pilot lamp in its socket.
- (✓) Install the black tube shield on V7 (12GN7) and the other tube shield on V6 (6CB6).
- (✓) Install the oscillator shield cover (#206-401) on the oscillator shield. Use #6 sheet metal screws.
- (✓) Carefully peel away the backing paper from the blue and white identification label. Then press the label onto the top of the chassis to the rear of the oscillator shield. Be sure to refer to the numbers on this label in any communications you have with the Heath Company about this kit.
- () In a clear space on the label, (with a ball point pen) write "28 MHz" or "50 MHz" according to the IF for which you assembled your kit.

This completes the Knob And Tube Installation.

INITIAL TESTS

IMPORTANT: Specifically check to make sure that:

1. The final plate coil is not touching the antenna link coil, and that neither coil is touching any other point it should not touch.
2. Be sure that the driver plate, final grid, and RF amplifier plate coils are not shorted to other components.
3. The ends of the red wire from relay BH and the large red wire from BO #8 are still taped.

To avoid damage caused from improper connections, make the following resistance tests to in-

sure that there are no short circuits in the power transformer wiring, and that the diode rectifiers have been installed with the correct polarity. To make these tests, use a meter which shows at least a ten-to-one difference in readings, on the R x 1000 range, when the meter leads across a diode are reversed. These tests were made with a meter which uses a 1.5 volt battery with the negative terminal connected to circuit ground.

Refer to Figures 1-1 and 1-2 (fold-out from Page 78) to identify parts above and below the chassis.

Set the ohmmeter range switch to R x 1000 and make the following resistance tests. **NOTE:** If your ohmmeter does not have this range, use the next higher setting.

<u>Common Lead</u>	<u>Positive Lead</u>	<u>Ohmmeter Reading</u>
A. Lug 1, terminal strip AE	1. Chassis 2. Capacitor AF	3000 to 5000 Ω Over 50 k Ω
B. Chassis	1. Lug 2, terminal strip AH 2. Capacitor AF 3. End of fuse-holder 4. Lug 3, terminal strip AU	3000 to 5000 Ω Over 50 k Ω Infinity Over 50 k Ω

WARNING: If any meter readings outside of the stated range were obtained, DO NOT CONNECT THE LINE PLUG INTO THE AC POWER OUTLET. Recheck your work and refer to In Case Of Difficulty on Page 125.

- (/) Make sure the OFF-ON switch is at OFF. Then plug the line cord into an electric outlet.
- (/) Turn the OFF-ON switch to ON. Turn the ~~shaft coupler by hand.~~

() Measure the AC voltage between lug 4 of terminal strip AB and the chassis. If this voltage is 13 to 14 VAC, there are no short circuits in the filament wiring. Refer to the In Case Of Difficulty section if you do not obtain the correct voltage.

() Turn the OFF-ON switch to OFF and disconnect the line cord and meter.

This completes the Initial Tests.

EQUIPMENT MODIFICATION

Modification instructions are given in the following pages for the following models of Heath equipment. Select the appropriate sections for your equipment and follow those steps only.

After the modification instructions for each model, you will find interconnection diagrams and a revised partial schematic diagram reflecting the wiring changes. Added wiring is shown in heavier lines.

<u>EQUIPMENT</u>	<u>PAGE</u>
SB-110 Transceiver.	84
SB-101 Transceiver.	90
HW-100 Transceiver.	101
SB-301/SB-401 Receiver-Transmitter combination.	106
Mobile Mount Modification.	110

9-terminal plastic connectors are used on the interconnecting cable and on the modified equipment. Either male or female terminals can be inserted in the body of a connector. Be

sure to follow the illustrations carefully to insure that each terminal is the correct type and is placed in its correct hole, as removal is difficult. An extractor tool (#490-112) is furnished so you can remove a terminal, should this be necessary. Use this tool to compress the expanded ears of the terminal so it may be withdrawn. Figure 2 illustrates the use of the extractor tool.

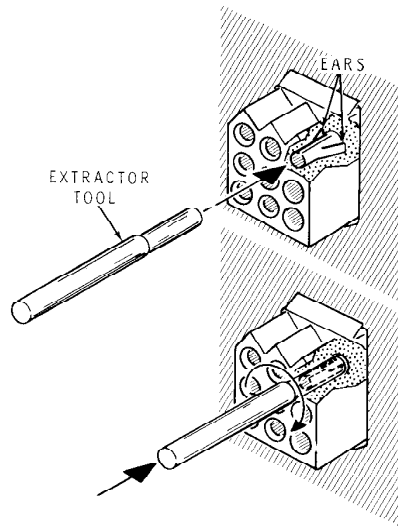
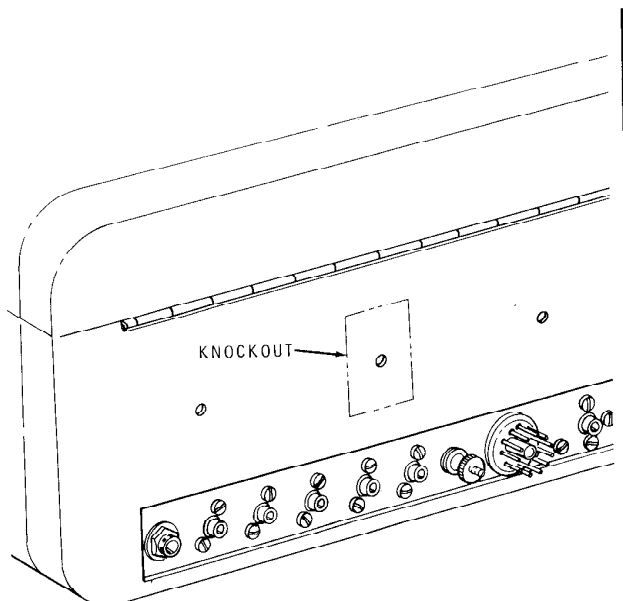

Figure 2

SB-110 TRANSCEIVER MODIFICATIONS



PICTORIAL 3-1

CABINET MODIFICATIONS

Refer to Pictorial 3-1 for the following steps.

- () Remove the Transceiver from its cabinet.
- () Locate the knockout rectangle that is located above the GND connection on the rear of the Transceiver cabinet.
- () Use a screwdriver or chisel to loosen the knockout. Then grasp one edge of the knockout with pliers, twist it loose, and discard it.

CHASSIS MODIFICATIONS

Refer to Pictorial 3-2 for the following steps.

- () Remove the tube shields and tubes from the carrier generator circuit board to provide easier access when performing the following steps.
- () Refer to Detail 3-2A and install a connector bracket (#204-751) on the side of the final shield. Use #6 x 3/8" sheet metal screws, with a #6 solder lug at B, positioned as shown. Insert the screw at corner hole A first.

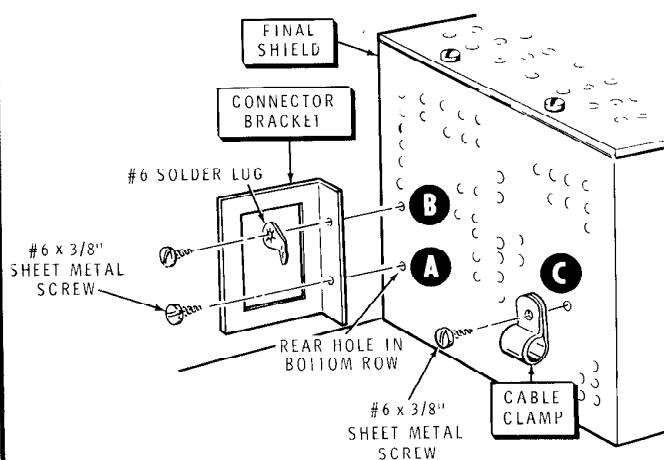

Detail 3-2A

- () Refer to Detail 3-2A and mount a cable clamp at C. Use a #6 x 3/8" sheet metal screw.
- () Refer to Detail 3-2B and install a 9-terminal chassis connector in the connector bracket. Position the grooves as shown.

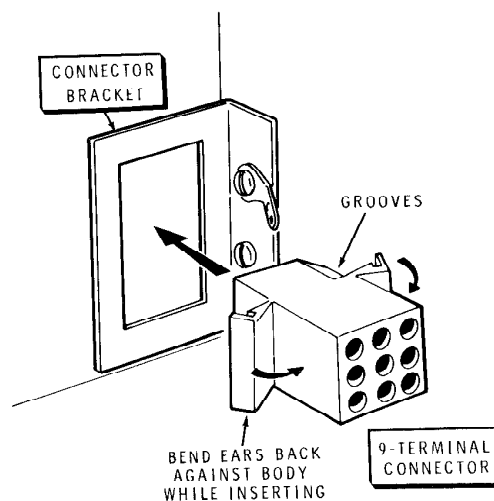

Detail 3-2B

() Prepare the following lengths of insulated wire:

- Red hookup 11-1/2"
- White-orange hookup 10-1/2"
- Yellow hookup 14"
- Gray hookup 1-1/2"

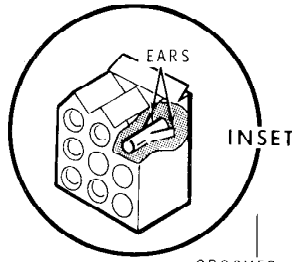

() Refer to Detail 3-2C and connect a male terminal to one end of each wire. Solder each connection.

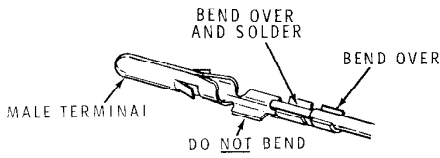

Detail 3-2C

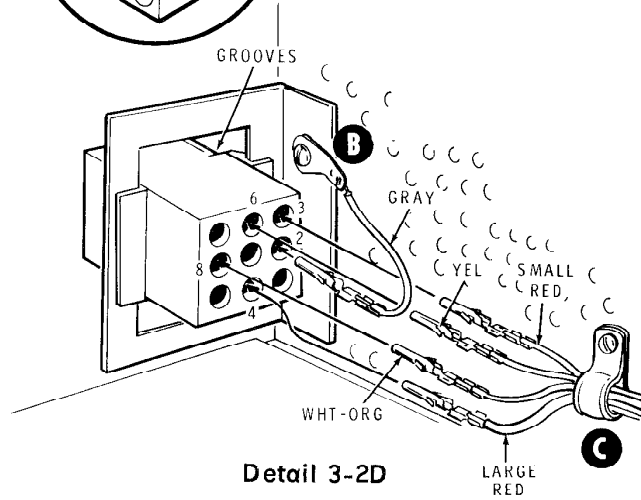

Detail 3-2D

() Prepare an 11-1/2" length of large red hookup wire.

() Refer again to Detail 3-2C and cut one male terminal at a point between the "Bend-Over-and-Solder" and the "Bend-Over" portions. Then solder one end of the large red wire to the "Bend-Over-and-Solder" portion of the terminal.

() Push the ends of all wires (except the gray wire) through cable clamp C toward the connector until the soldered terminals are about 4-1/2" from the clamp.

Refer to Detail 3-2D for the proper method of inserting the terminals into the connector in the following steps. The inset drawing shows how the metal ears expand to lock each terminal in place. CAUTION: Be very sure you use the right hole for each wire, as withdrawal is difficult. However, if the removal of a terminal is unavoidable, refer to Figure 2 on Page 83.

() Push the gray wire terminal into hole #2 until it locks into place. Connect the other end of this wire to solder lug B (S-1).

Insert the terminals on the other prepared wires into holes as follows:

- | WIRE | HOLE |
|------------------|------|
| () Large red | #4 |
| () Small red | #3 |
| () Yellow | #6 |
| () White-orange | #8 |
- () Make sure there is adequate slack in the wires at the rear of the connector, as shown in the Pictorial. Avoid placing any strain on the terminals through the wires.
- () Position the large red wire as shown in the Pictorial and connect it to feedthrough capacitor LB (S-1). (Two red wires should now be connected to LB, which is C140 on the SB-110 schematic.)
- () Push the three remaining wires from the cable clamp down through grommet BD, past the wires from breakout #6.
- () Replace the tubes and tube shields on the carrier generator circuit board.

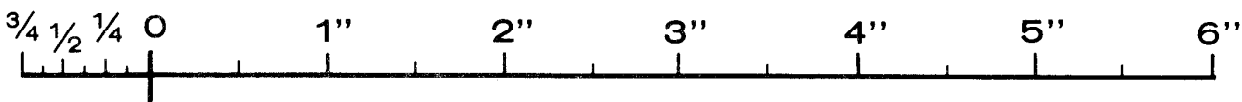

UNDER-CHASSIS MODIFICATIONS

Refer to Pictorial 3-3 (fold-out from this Page) for the following steps.

- () Refer to Detail 3-3A and install a .001 μ F (brown-black-red) feedthrough capacitor in the unused hole next to AU in the driver shield. Do not overtighten, as this capacitor can be easily damaged.
- () Connect the free end of the red wire from grommet BD to feedthrough capacitor AU (S-1).
- () Connect the free end of the white-orange wire coming from grommet BD to the added feedthrough capacitor (S-1).

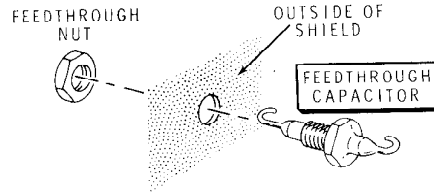

Detail 3-3A

- () Refer to Detail 3-3B. Unsolder and remove the lead of the 100 Ω (brown-black-brown) 2 watt resistor from feedthrough capacitor AU. Bend a small hook in the end of this lead.

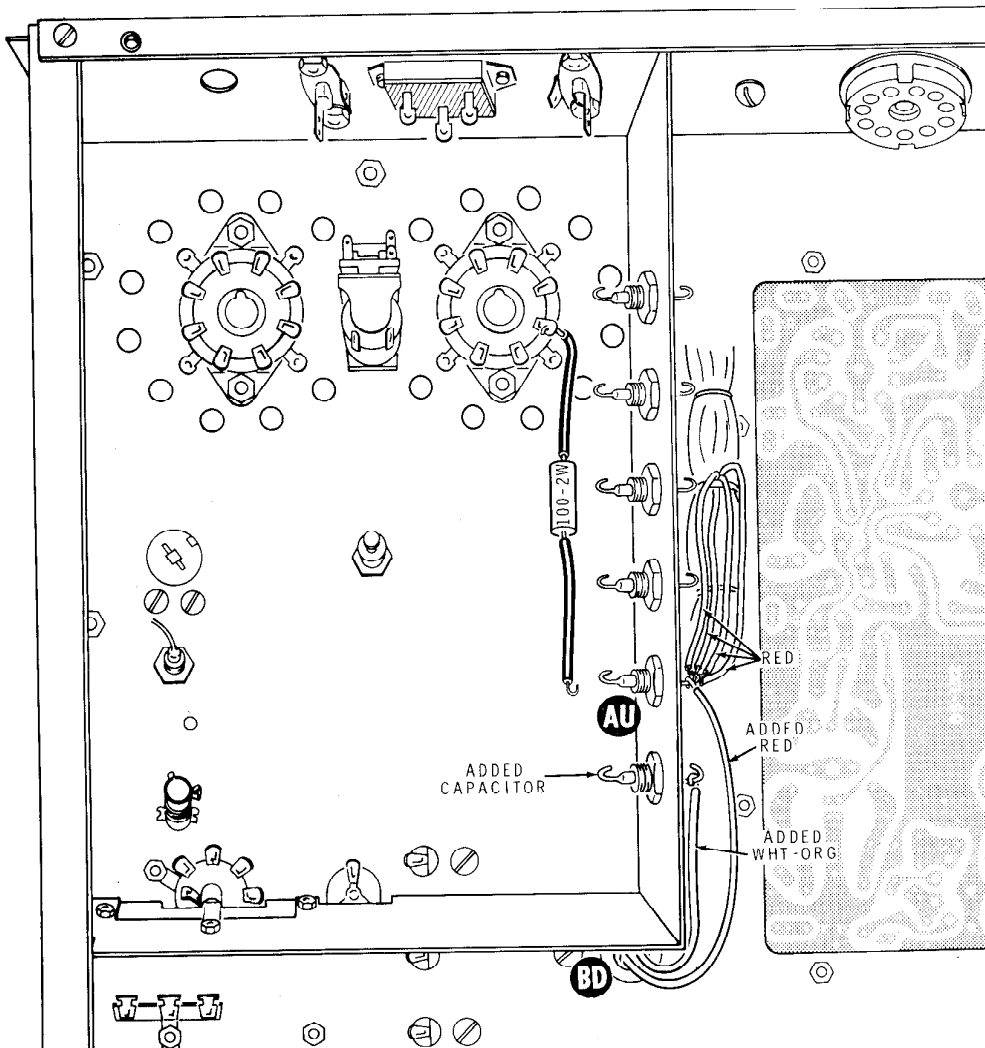

Detail 3-3B

- () Prepare a 1-1/4" length of red hookup wire and bend a small hook in the bare wire at one end.
- () Connect the hooked leads of the 100 Ω resistor and the hookup wire. Solder and tape the connection.
- () Connect the free end of the hookup wire to the added feedthrough capacitor as shown in the Pictorial (S-1).
- () Connect the free end of the yellow wire coming from grommet BD to lug 15 of terminal strip DA (S-1). This wire joins one green wire previously soldered to this lug.

- () Refer to Part B of Detail 3-3D and, at the 1" end of the prepared coaxial cable, connect the center conductor to lug 2 (S-1) and the shield wires to lug 1 (S-1) of phono socket AC. Other shield wires will be found already soldered to lug 1.

- () Refer to Detail 3-3C and prepare a 10" length of small coaxial cable.

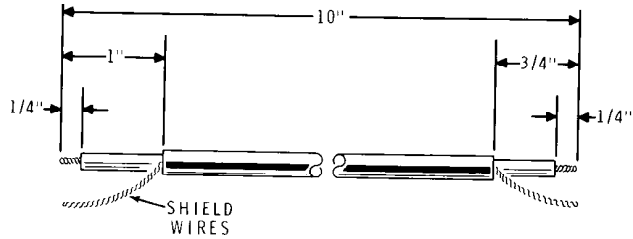

Detail 3-3C

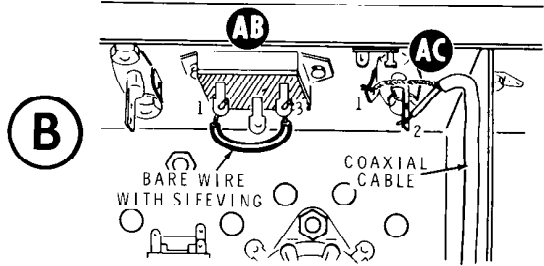
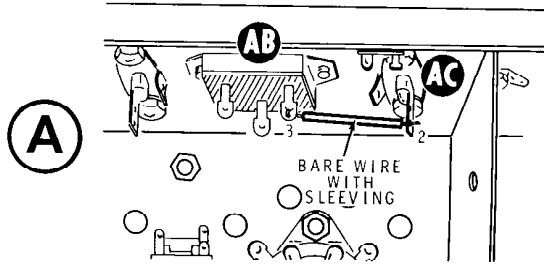

Detail 3-3D

- () Refer to Detail 3-3D, Part A, and remove the end of the bare wire from lug 2 of phono socket AC. Reconnect this wire to lug 1 of switch AB (S-1) as shown in Part B of the Detail.

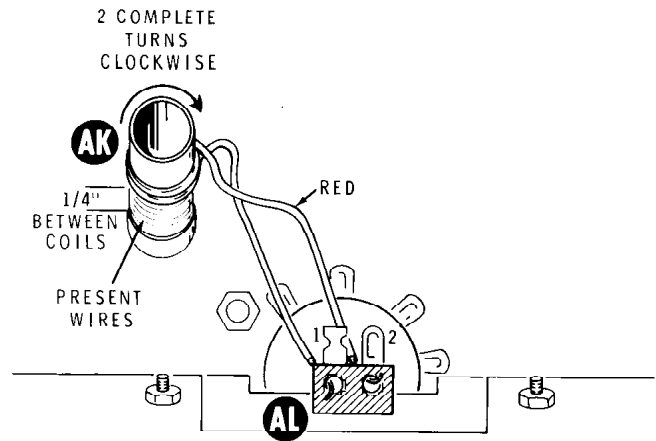
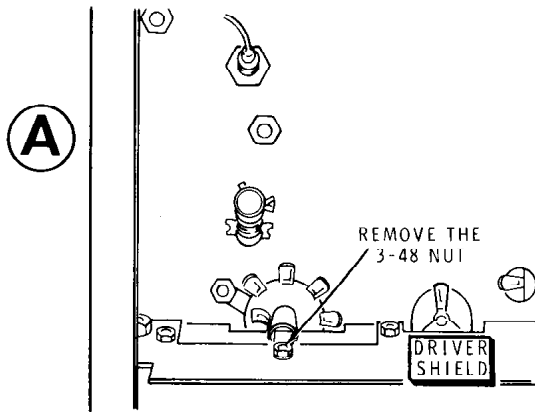

Detail 3-3F

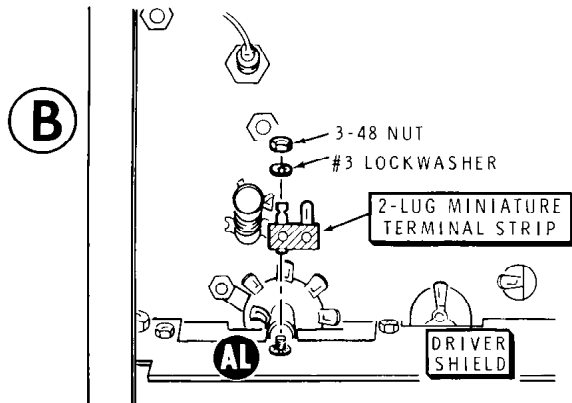

Detail 3-3E

- () Refer to Detail 3-3E, Part A, and remove the 3-48 nut only from the 3-48 x 1/4" screw in the center of the tube socket shield mounted on the driver shield.
- () Refer to Part B of the Detail and mount a 2-lug miniature terminal strip (#431-57) on the 3-48 screw with the mounting foot pointing down. Add a #3 lockwasher and replace the 3-48 nut.
- () Connect one end of a 4" red hookup wire to the eyelet in lug 1 of the 2-lug terminal strip (S-1).
- () Refer to Detail 3-3F and make two complete turns of the red hookup wire around coil AK starting 1/4" above the existing wiring. **IMPORTANT:** Be sure to wind the wire in a clockwise direction toward the open end of the coil form. Then connect the free end to the eyelet in lug 2 of the 2-lug terminal strip (S-1).
- () At the free end of the 10" small coaxial cable, connect the center conductor to lug 2 (S-1) and the shield wire to lug 1 (S-1) of the 2-lug terminal strip.

This completes chassis wiring modifications of the SB-110 Transceiver. Refer to Figure 3-1 for a partial schematic showing wiring changes. Refer to Figure 3-2 (fold-out from Page 89) for the interconnection diagram.

Proceed to Alignment on Page 111.

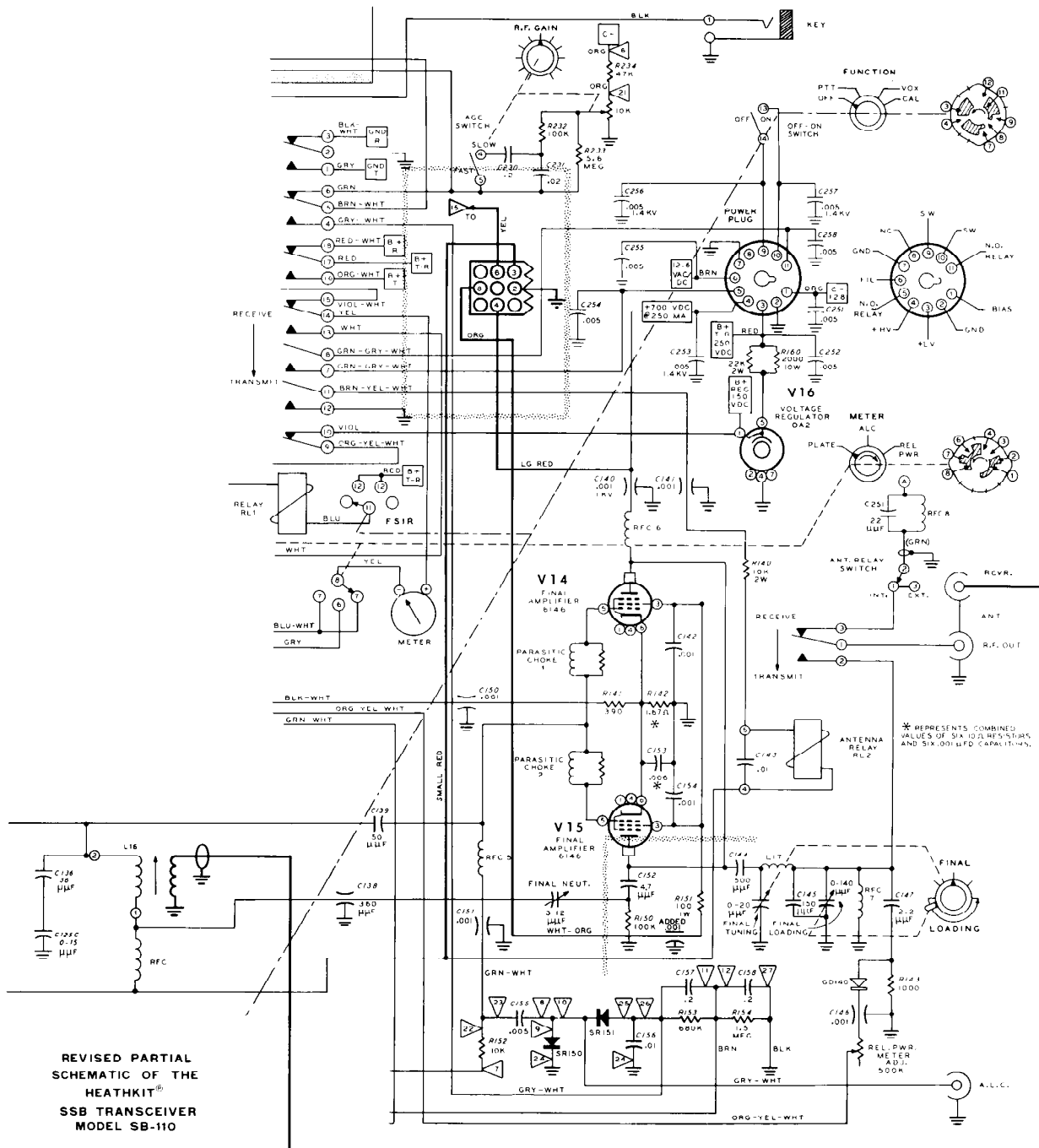

REVISED PARTIAL SCHEMATIC OF THE HEATHKIT® SSB TRANSCEIVER MODEL SB-110

Figure 3-1

SB-101 TRANSCEIVER MODIFICATIONS

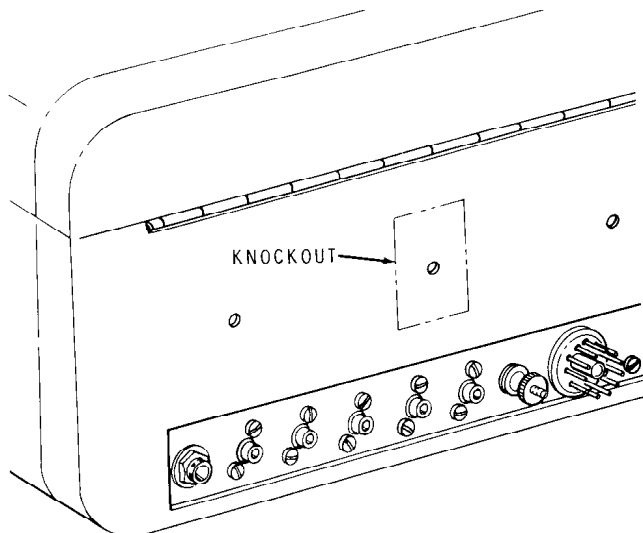

PICTORIAL 4-1

- () Use a screwdriver or chisel to loosen the knockout. Then grasp one edge of the knockout with pliers, twist it loose, and discard it.

CHASSIS MODIFICATION

There are two different groups of modification steps for the SB-101 chassis. If your Transceiver has not been previously modified, follow only the steps under "Unmodified SB-101". If your Transceiver has been modified for use with the Model SB-640 External LMO, follow only the steps under "Modified SB-101".

Unmodified SB-101

Refer to Pictorial 4-2 for the following steps.

CABINET MODIFICATION

Refer to Pictorial 4-1 for the following steps.

- () Remove the Transceiver from its cabinet.
- () Locate the knockout rectangle that is located above the GND connection on the rear of the Transceiver cabinet.

- () Locate the unused hole next to BC, the Bias Adjust control. Install a 5/16" grommet in this hole.
- () Remove the RF cage top and rear plates. Lay them and the retaining screws aside temporarily.

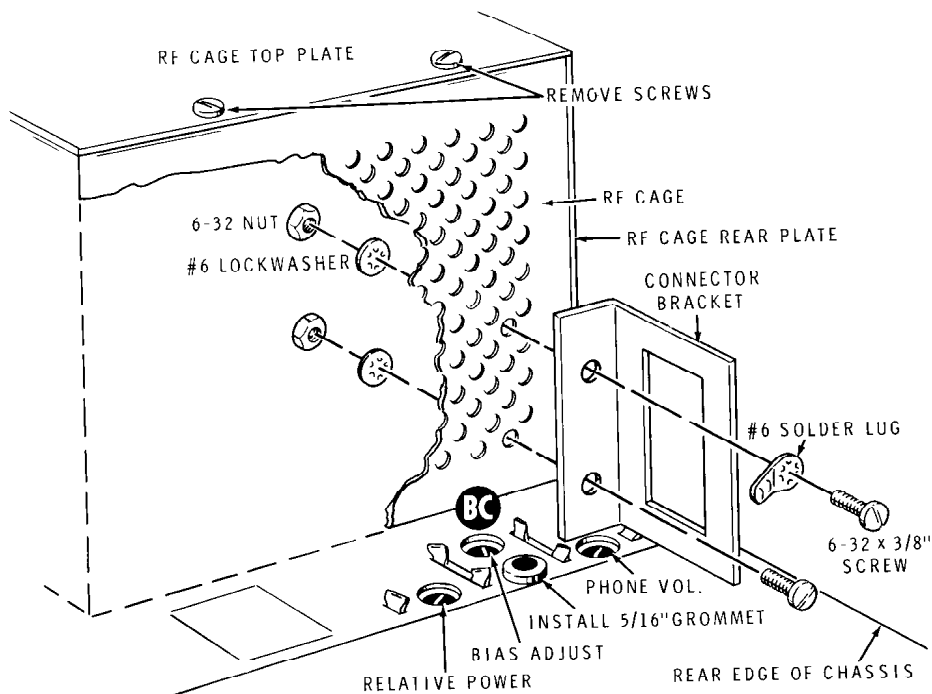

Detail 4-2A

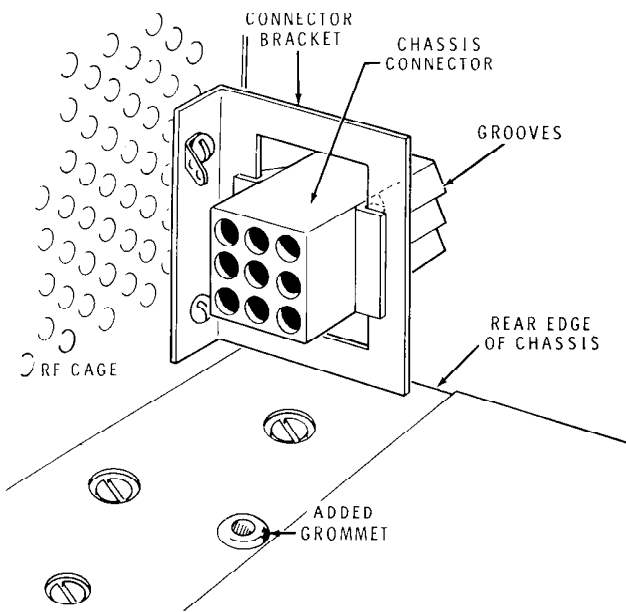

PICTORIAL 4-2

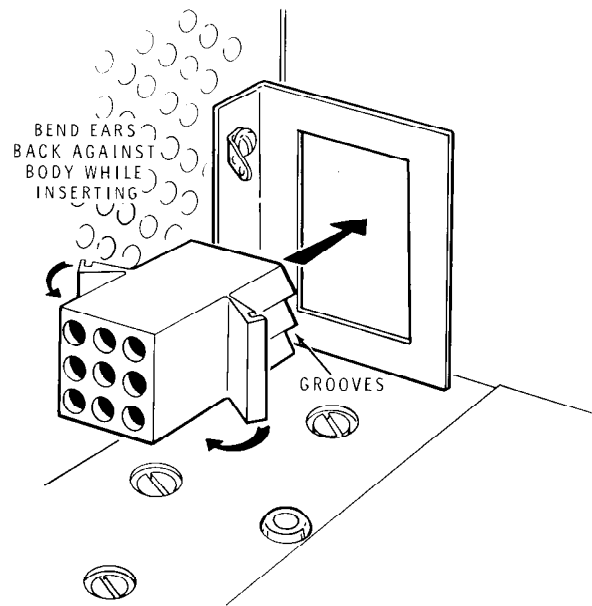

Detail 4-2B

- () Install a bracket (#204-751) on the side of the RF cage. Use 6-32 x 3/8" hardware and a #6 solder lug at the upper hole. Use 6-32 x 3/8" hardware at the lower hole.

NOTE: Be sure to position the bracket mounting lip and the solder lug as shown, and to use the mounting holes indicated in the RF cage. To permit easier access to screw heads, temporarily remove V18 while you mount the bracket. If the rear mounting lug of the Phone Volume control interferes, bend the lug enough to clear the bracket.

- () Replace the two RF cage plates, the retaining screws, and V18.
- () Refer to Detail 4-2B and install a 9-terminal chassis connector in the bracket. Be sure to position the grooves as shown. Bend the retaining ears back against the body of the connector while inserting it in the bracket.

Turn to the Connector And Chassis Wiring on Page 92.

Modified 5B-101

Refer to Pictorial 4-3 for the following steps.

- () Refer to Detail 4-3A; then untwist and straighten the mounting tabs of the Phone Volume control. Push the tabs down out of their mounting slots and move the control to one side under the chassis.

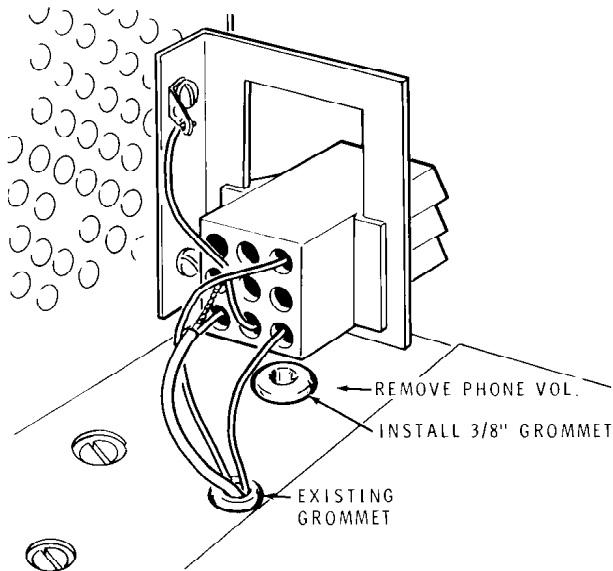

Detail 4-3A

- () Refer to the same Detail and install a 3/8" plastic grommet in the chassis hole vacated by the control.
- () Position the chassis connector for the SB-640 External LMO at the bottom of the connector bracket slot.
- () Refer to Detail 4-3B and install a 9-terminal chassis connector in the connector bracket above the External LMO connector.
- () Replace the RF cage top plate, rear plate, and V18.

Connector And Chassis Wiring

Refer to Pictorial 4-4 for the following steps.

NOTE: Wire routing is shown in Part A of the Pictorial for *UNMODIFIED* Transceivers, and in Part B for *MODIFIED* Transceivers.

- () Prepare the following lengths of hookup wire:

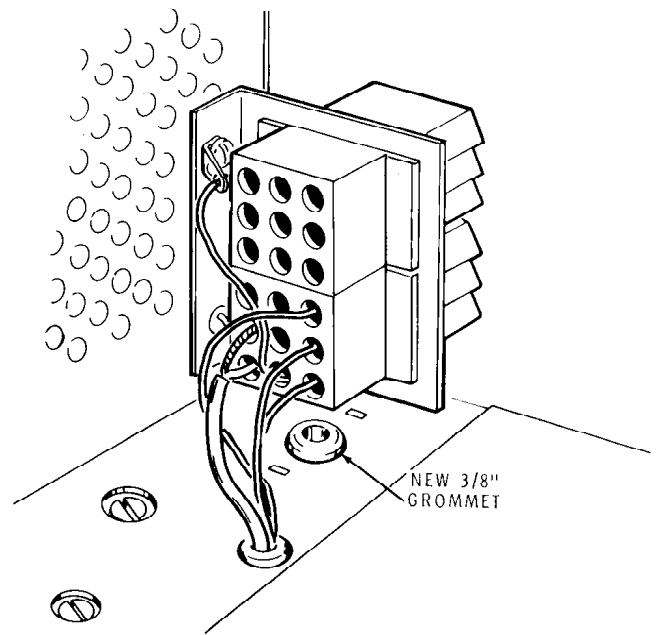

PICTORIAL 4-3

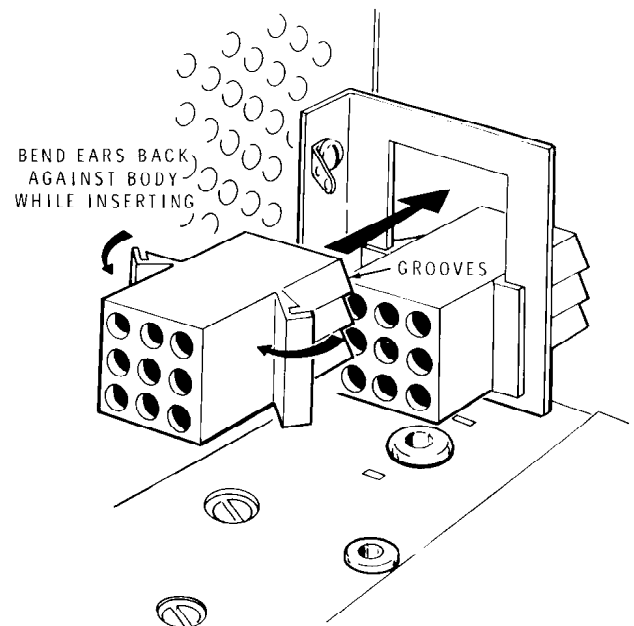

Detail 4-3B

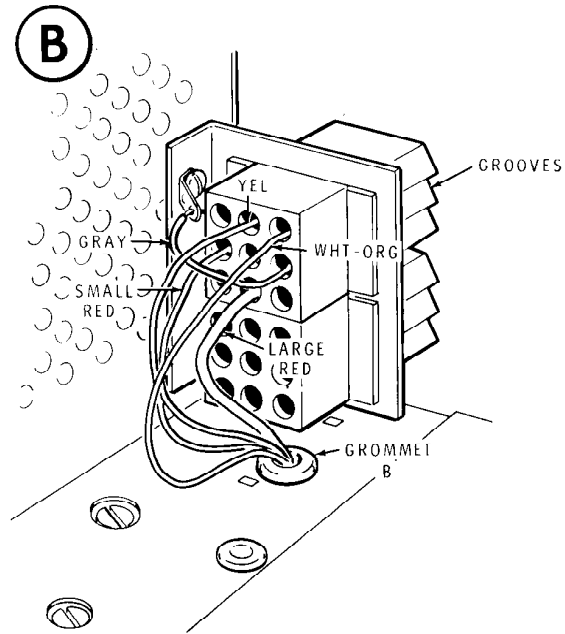
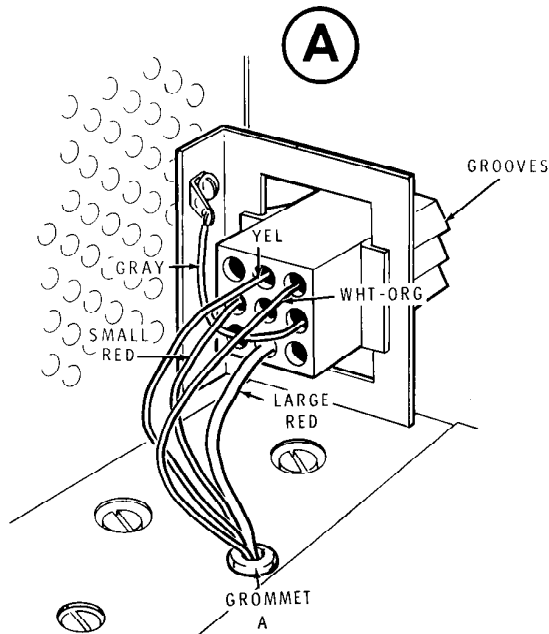

PICTORIAL 4-4

Color	Length
Small red	17-1/2"
Gray	3"
Yellow	21"
White-orange	19"

() Refer to Detail 4-4A and connect a male terminal to one end of each of the wires prepared in the preceding step.

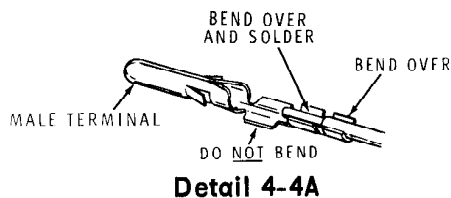

- () Prepare a 7" large red wire.
- () Refer again to Detail 4-4A and cut one male terminal at a point between the "Bend-Over-and-Solder" and the "Bend-Over" portions. Then solder one end of the large red wire, to the "Bend-Over-and-Solder" portion of the terminal.

CAUTION: When you insert terminals in a connector, be sure to use the correct holes, as withdrawal is difficult. Also be sure the terminals are fully seated, so the terminal ears expand to prevent withdrawal. However, if re-

moval of a wire is unavoidable, refer to Figure 2 on Page 83.

() Refer to Detail 4-4B and insert the terminal on the gray wire into hole 2 in the chassis connector. Connect the other end of this wire to the solder lug on the upper bracket mounting screw (S-1). **NOTE:** If your Transceiver is the *MODIFIED* version, there will now be one black wire and one gray wire connected to this solder lug.

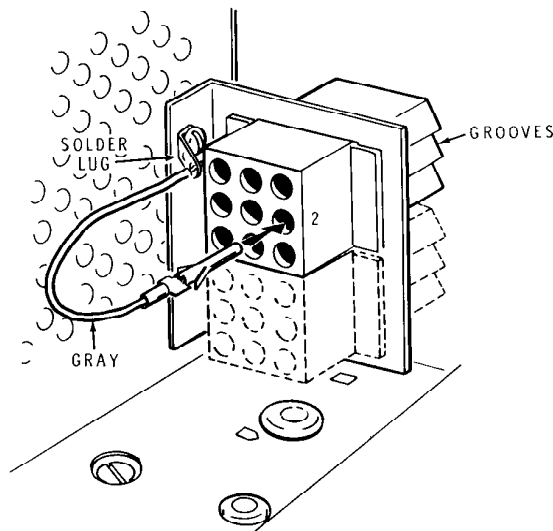

Detail 4-4B

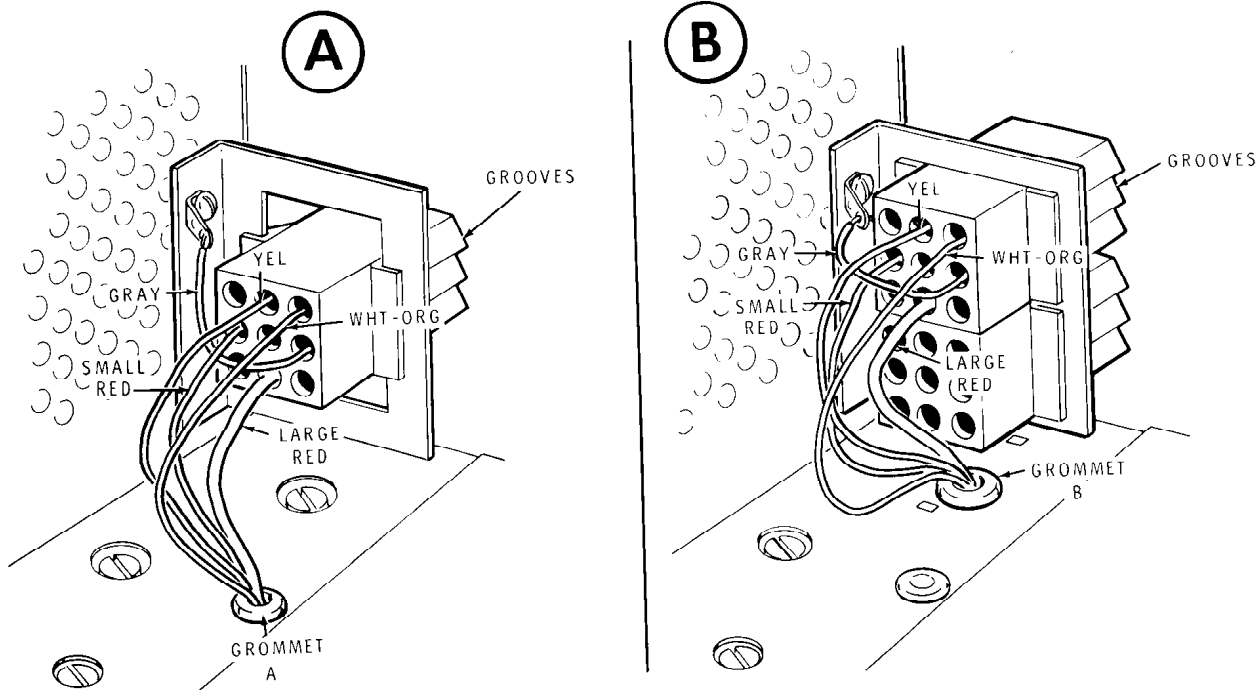

PICTORIAL 4-4
(Repeat)

Refer to Detail 4-4C and insert the terminals on the remaining four wires into the following chassis connector holes:

WIRE	HOLE
() Large red*	4
() Small red	8
() Yellow	6
() White-orange	3

*Remove an additional 1/2" of insulation from the free end (total 3/4").

Perform only one of the next two steps. In either step, leave a reasonable amount of slack in the wires above the chassis, as shown.

- () If you have the *UNMODIFIED* Transceiver, refer to Part A of Pictorial 4-4 and pass the free ends of the four connector wires down through grommet A to the bottom of the chassis.

- () If you have the *MODIFIED* Transceiver, refer to Part B of Pictorial 4-4 and pass the free ends of the four connector wires down through grommet B to the bottom of the chassis.

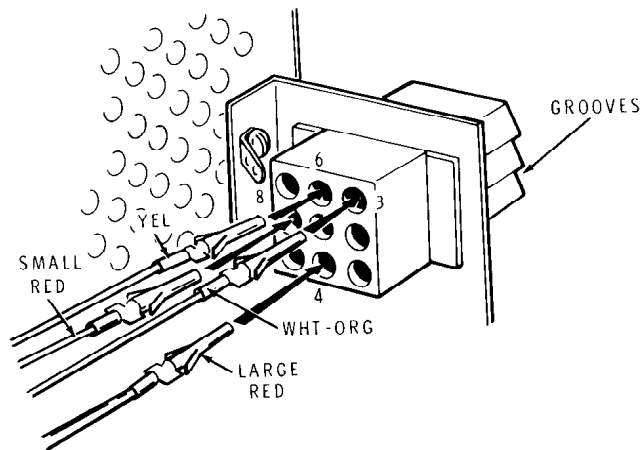

Detail 4-4C

Refer to Pictorial 4-5 (fold-out from Page 90) for the following steps.

NOTE: This Pictorial shows the four connector wires coming from grommet B, as they appear in the *MODIFIED SB-101* Transceiver. If your Transceiver was not modified for use with the SB-640 External LMO, these four wires will come from grommet A. Other than the removal of the Phone Volume control, this is the only under-chassis difference.

- () Unsolder all connections to the Phone Volume control and discard the control.

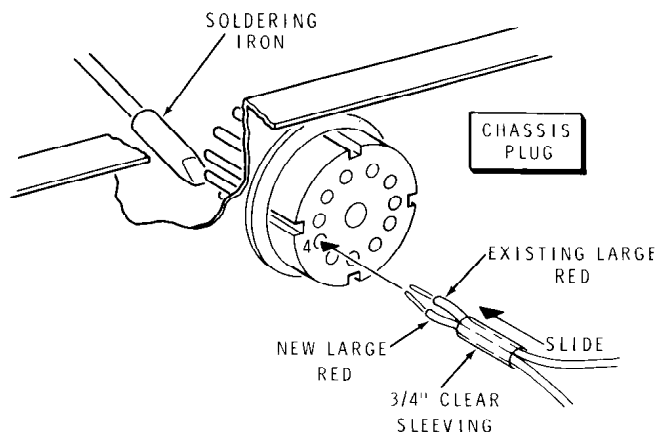

Detail 4-5A

NOTE: Perform only two of the next four steps. If a spare phono socket is available on the rear apron, use it as a terminal strip and reconnect the wires which originally went to the Phone Volume control as directed in steps 1 and 2. If no spare phono socket is available, disregard steps 1 and 2 and connect these wires as directed in steps 3 and 4.

- () 1. Connect the center conductor of the GRN coaxial cable to the center lug (NS) and the shield wires to the ground lug (S-1) of an unused phono socket.
- () 2. Connect the black hookup wire to the center lug of the phono socket (S-2).
- () 3. Connect the center conductor of the GRN coaxial cable to the black hookup wire (S-1). Tape the soldered connection.

- () 4. Connect the coaxial cable shield wires to the grounded lug of a nearby phono socket.
- () Unsolder and remove the end of the existing large red wire from pin 4 of the 11-pin plug on the rear apron. While you have the pin hot, free it of solder with a hat pin or large darning needle (hold a darning needle with pliers - it will get hot!).
- () Refer to Detail 4-5A and slide a 3/4" length of clear sleeving over both the large red wire removed from pin 4 and the large red wire coming from the grommet. Then insert both these wires into pin 4 of the chassis plug, being sure the insulation is snug against the plug face (S-2). After the solder joint has cooled, slide the clear sleeving up against the plug face.

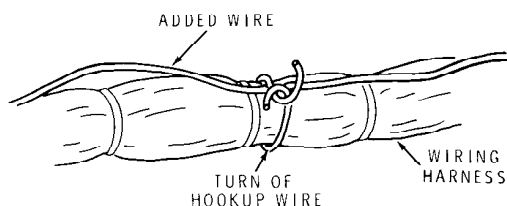

Detail 4-5B

NOTE: To reduce confusion, Pictorial 4-5 omits most existing wiring. The three wires to be connected now should follow the existing wiring harness. To hold the wires in place, you can pass tape around both the added wires and the wiring harness every few inches, or you can take a turn of hookup wire around all the wires as shown in Detail 4-5B.

- () Connect the yellow wire to 13 on the IF circuit board (S-1). Make the connection direct to the foil. A total of three yellow wires will now be connected to this point.
- () Insert the small red and the white-orange wires through grommet CF and pull them snug.
- () Disconnect the white wire from lug 1 of terminal strip BM.
- () Connect the small red wire from grommet CF to lug 1 of terminal strip BM (S-1). This red wire and a 100 Ω (brown-black-brown) resistor should now be connected to this terminal.
- () Disconnect the other end of the white wire from lug 1 of terminal strip BN. Save this wire.
- () Disconnect the center conductor of the violet coaxial cable from lug 2 of terminal strip BN. Leave the shield wires connected to lug 3.
- () Connect the center conductor of the violet coaxial cable to one end of the white wire removed previously (S-1). Then tape the joint to avoid short circuits.
- () Connect the other end of the white wire to lug 6 of terminal strip EA (S-1). In addition to this white wire, there should now be connected to this lug the anode lead of a diode, a black wire, and two white-violet-violet wires.
- () Connect the white-orange wire from grommet CF to lug 1 of terminal strip BN (S-1). In addition to this white-orange wire, there should now be connected to this lug a white-orange-orange wire, a white wire, a .005 μ F disc capacitor, and a 47 k Ω (yellow-violet-orange) resistor.

Refer to Pictorial 4-6 for the following steps.

NOTE: Part A of this Pictorial shows the wiring before modification, and Part B shows the final shield area after the following steps are completed.

- () Unsolder and remove the bare wire from relay contact 3.
- () Reconnect this wire to relay contact 7 (S-1). Be sure the wire does not touch any other relay contacts.
- () Clip out and discard the bare wire between lug 2 of phono socket AJ and lug 2 of switch AK. Lug 2 of socket AJ will now be connected only to lug 12 of the relay.
- () Unsolder and remove the 8.5 MHz trap assembly.
- () Solder one lead of the 8.5 MHz trap assembly to both lugs 3 and 4 of the relay. Solder the other lead to solder lug BS.
- () Replace the Transceiver in its cabinet.

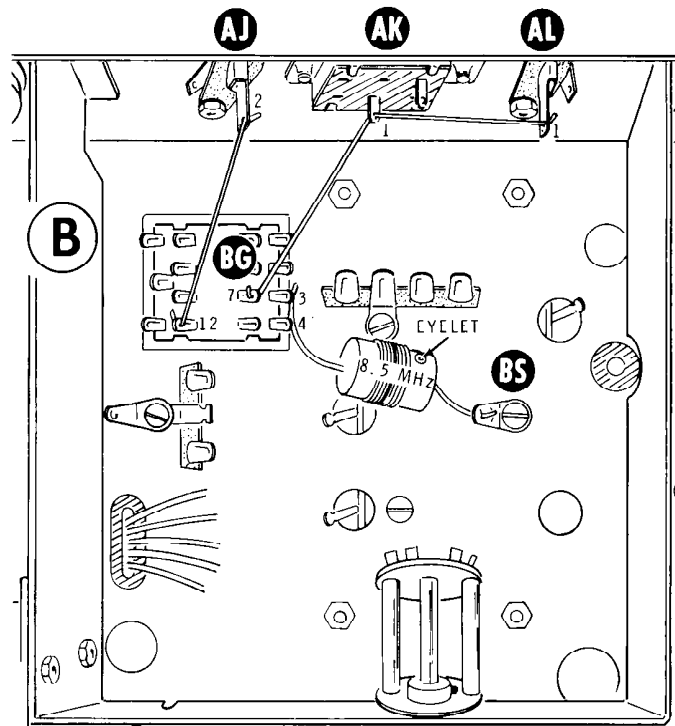
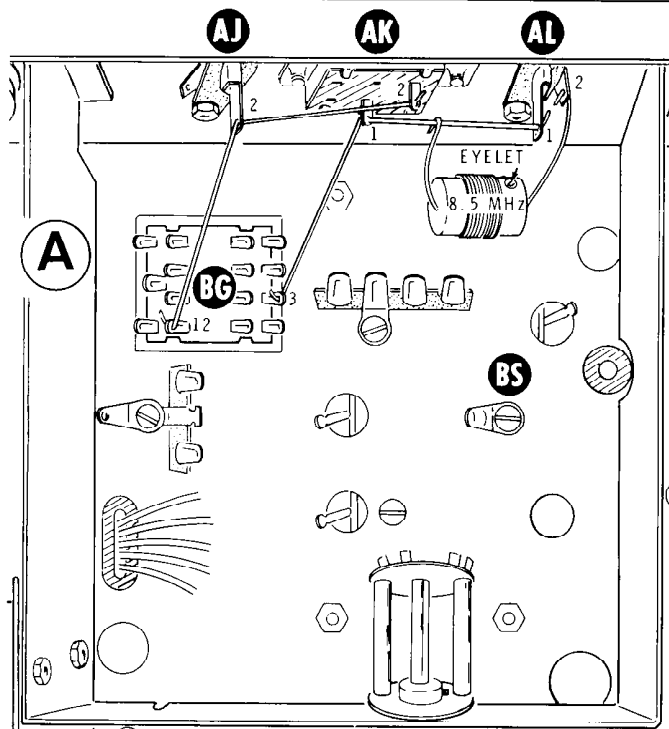

Refer to Figure 4-1 on Page 98 for a partial schematic showing the wiring changes made in the foregoing steps. Refer to Figure 4-2 for a diagram showing interconnections between the SB-101 Transceiver and the SB-500 Transverter.

PICTORIAL 4-6

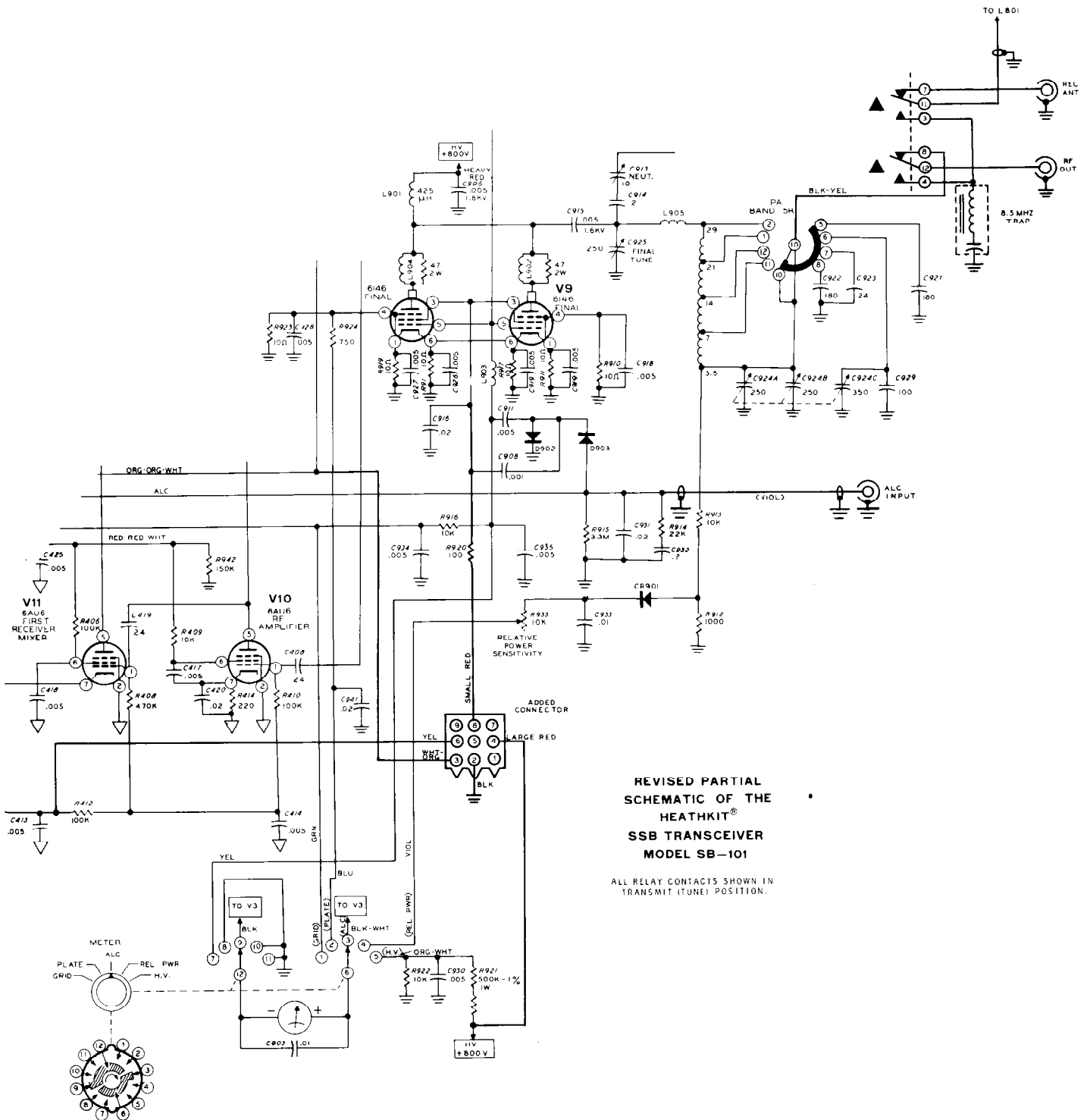

Figure 4-1

This completes the Modification steps. If you do not use an amplifier, proceed to Alignment section (Page 111). If you use the SB-200 Linear Amplifier, refer to Figure 4-3 and the following steps.

In the following steps, you will connect the ALC line from the Transceiver to the ALC line from the Linear Amplifier at the Transverter's ALC phono plug.

- () Unsolder and remove the phono plug from one end of the ALC line from the Transceiver.
- () Cut a coaxial cable to reach between the Transverter and the Linear Amplifier ALC connectors.

Refer to Pictorial 4-7 for the following steps.

- () As shown in Part A, prepare the end of the cable from which the phono plug was removed.
- () In like manner, prepare one end of the coaxial line which will run between the ALC connectors of the Transverter and Linear Amplifier.
- () Refer to Part B of the Pictorial and twist the two ALC line center conductors tightly together; melt a small amount of solder on the wires to hold them together.
- () Similarly, twist together and solder the shield wires.

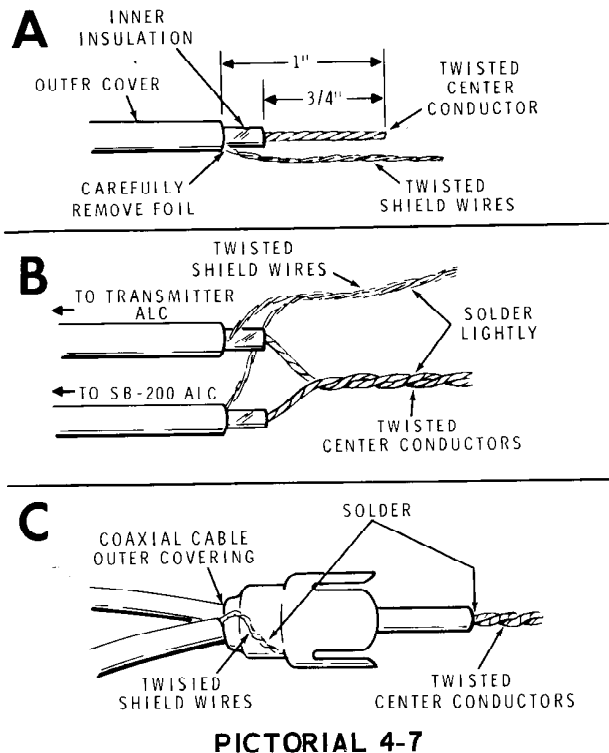

- () Reinstall the removed phono plug on the two joined coaxial cables as shown in Part C of the Pictorial. Trim off the excess center conductor and shield wires.
- () Refer back to Pictorial 2-16 on Page 74 and install a phono plug for the Linear Amplifier ALC connection on the free end of the coaxial cable.

This completes the Modification. Proceed to the Alignment section (Page 111).

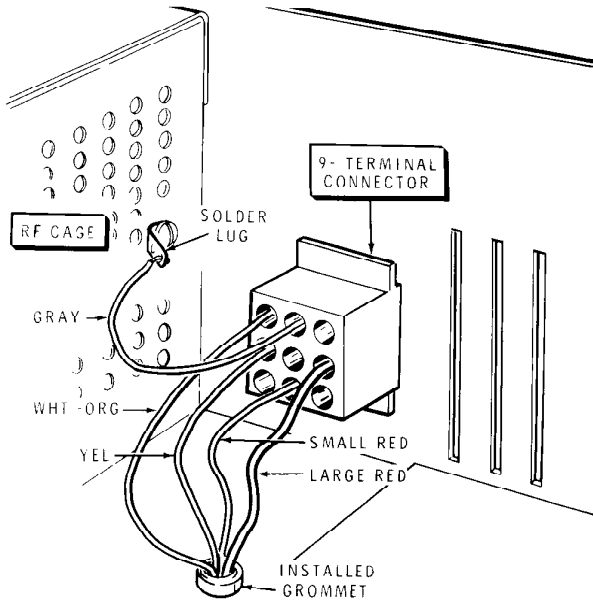

PICTORIAL 6-2

Refer to Pictorial 6-2 for the following steps.

- () Prepare the following lengths of hookup wire:

Color	Length
Small red	16-1/2"
Gray	3"
Yellow	21"
White-orange	19"

- () Refer to Detail 6-2A and connect a male terminal to one end only of each of the wires prepared in the preceding step.

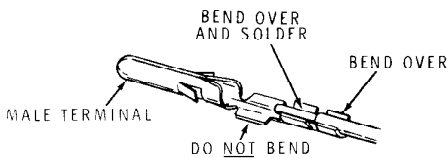

Detail 6-2A

- () Prepare a 7" length of large red hookup wire.
- () Refer again to Detail 6-2A and cut one male terminal at a point between the "Bend-Over-and-Solder" and the "Bend-Over" portions. Then solder one end of the large red wire, to the "Bend-Over-and Solder" portion of the terminal.
- () Remove a total of 3/4" of insulation from the free end of the large red wire.

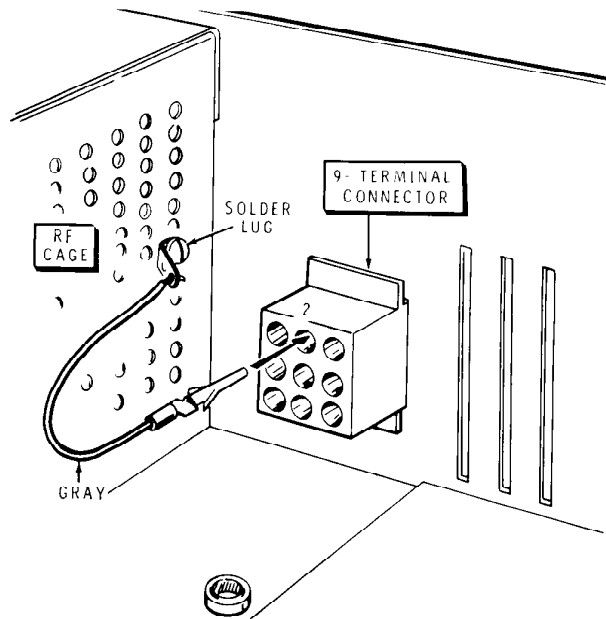

Detail 6-2B

CAUTION: In the following steps, be sure to use the correct holes when you insert terminals in the connector. Also be sure the terminals are fully seated so their ears expand to prevent withdrawal. However, if withdrawal is unavoidable, refer to Figure 2 on Page 83.

- () Refer to Detail 6-2B, determine the hole carefully, and insert the terminal on the gray wire all the way into hole #2 of the connector. Connect the free end of this wire to the #6 solder lug just installed on the RF cage (S-1).

Refer to Detail 6-2C and insert the terminals on the remaining four wires into the following holes in the chassis connector:

WIRE	HOLE
(✓) Large red	4
() Small red	8
(✓) Yellow	6
() White-orange	3

() Pass the free ends of the four wires in the preceding step down through the newly installed grommet to the bottom of the chassis. Pull the wires through the grommet, but leave an adequate amount of slack in the wires above the chassis.

() Replace tube V18 in its socket.

Refer to Pictorial 6-3 for the following steps.

NOTE: In the following step, Detail 6-3A is shown full scale so that it may be cut out and used as a drilling template for the Driver Output phono socket to be added.

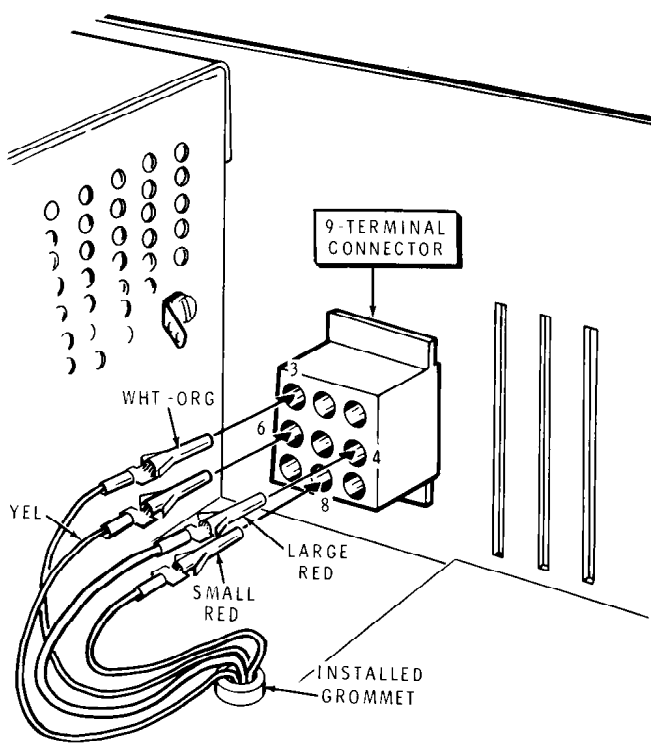

Detail 6-2C

() Refer to Detail 6-3A for the correct layout, and then drill the mounting holes for the driver phono socket. Measure very carefully and center-punch the holes before drilling. Be careful that your drill does not creep. A #28 drill can be used instead of the 9/64" drill.

() Refer to Detail 6-3B and install a phono socket in the holes prepared in the preceding step. Use 6-32 x 3/8" hardware. Position the ground (shorter) lug away from the antenna phono socket. This is the Driver phono socket.

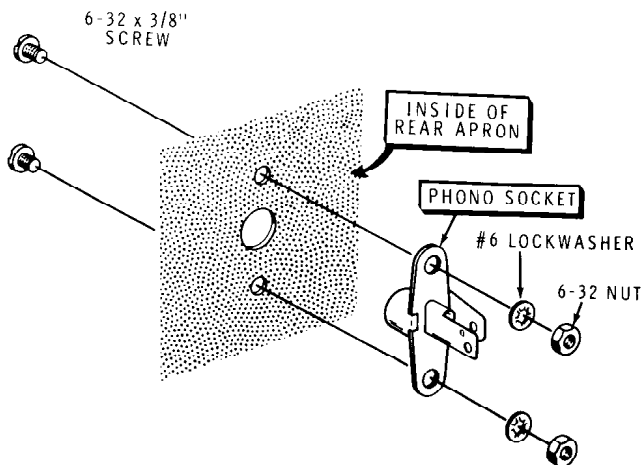

Detail 6-3B

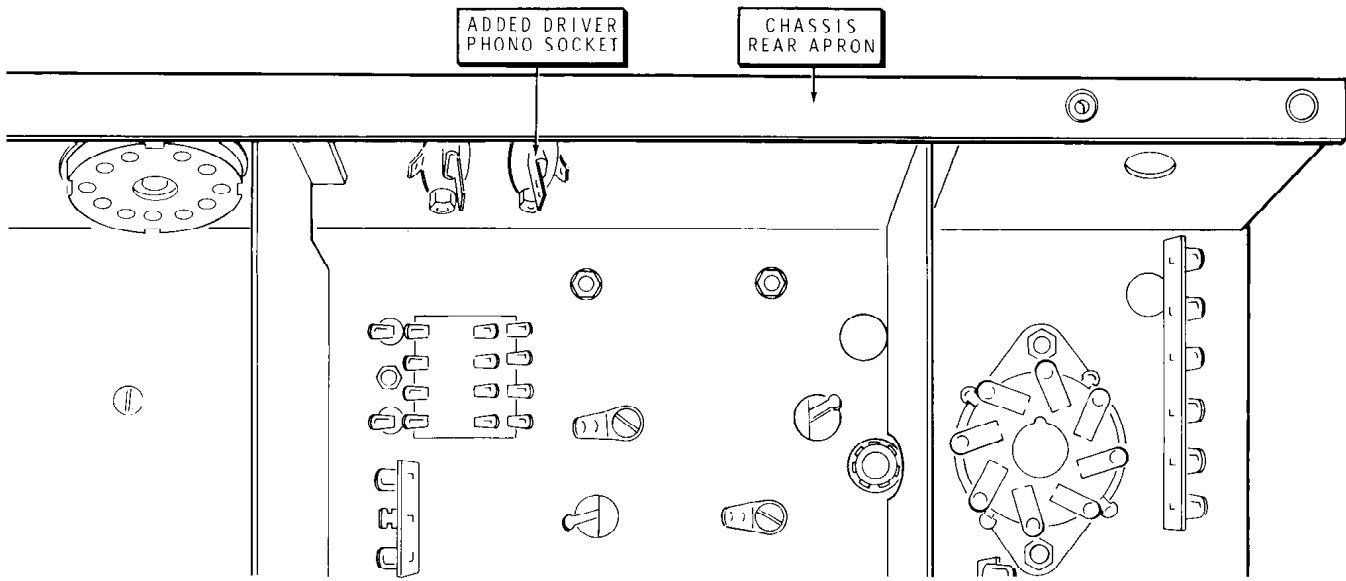

PICTORIAL 6-3

BOTTOM CHASSIS WIRING

Refer to Pictorial 6-4 for the following steps.

NOTE: Part A of the Pictorial shows the final switch shield area before modification, and Part B shows the same area after the wiring changes are completed.

- () Unsolder the center conductor of the coaxial cable and the lead of the 8.5 MHz trap from lug 4 of the relay. Bend the trap back and away from the relay.
- () Unsolder and remove the shield wires of the coaxial cable from solder lug BG.
- () Reconnect the center conductor of the coaxial cable to lug 11 (S-1) and the shield wires to the bare wire at lug 9 (S-1) of the relay. Carefully inspect the shield wires to make sure that no stray strands cause an undesired connection.
- () Form the free lead of the 8.5 MHz trap as shown in the Pictorial so it will contact both lugs 3 and 4 of the relay (S-2).
- () Connect a 1-1/2" yellow hookup wire from lug 7 of the relay (S-1) to lug 1 of the new phono socket (S-1).

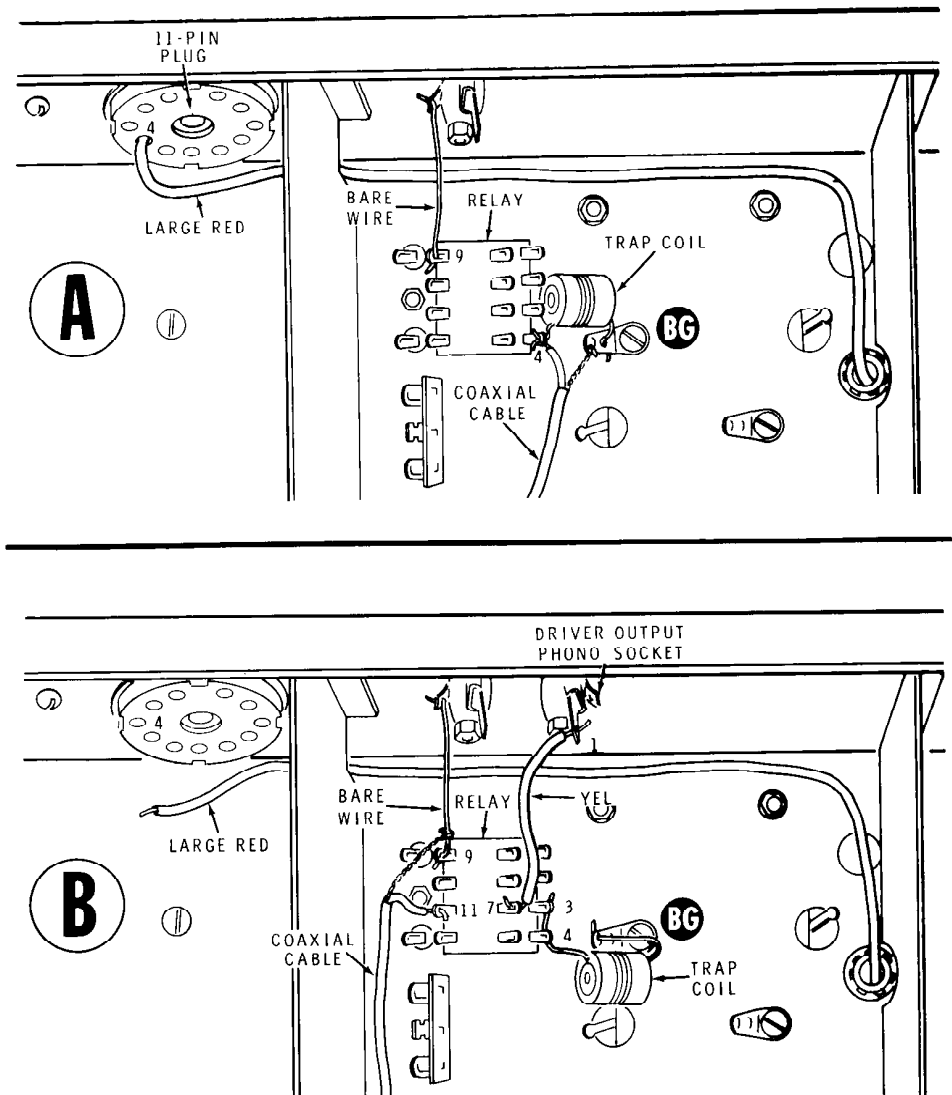

PICTORIAL 6-4

If you use the SB-200 Linear Amplifier, refer to Figure 6-3 and the following steps.

In the following steps, you will connect the ALC line from the Transceiver to the ALC line from the Linear Amplifier at the Transverter's ALC phono plug.

- () Unsolder and remove the phono plug from one end of the ALC line from the Transceiver.
- () Cut a coaxial cable to reach between the Transverter and the Linear Amplifier ALC connectors.

Refer to Pictorial 6-6 for the following steps.

- () As shown in Part A, prepare the end of the cable from which the phono plug was removed.
- () In like manner, prepare one end of the coaxial line which will run between the ALC connectors of the SB-500 and the Linear Amplifier.
- () Refer to Part B of the Pictorial and twist the two ALC line center conductors tightly together; melt a small amount of solder on the wires to hold them together.
- () Similarly, twist together and solder the shield wires.
- () Reinstall the removed phono plug on the two joined coaxial cables as shown in Part C of the Pictorial. Trim off excess center conductor and shield wires.

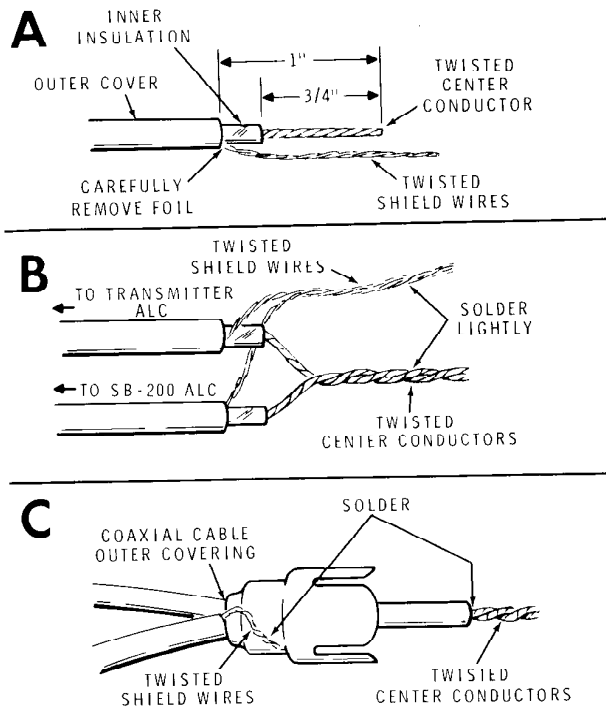

PICTORIAL 6-6

- () Refer back to Pictorial 2-16 on Page 74 and install a phono plug for the Linear Amplifier ALC connection on the free end of the coaxial cable.

Proceed to the Alignment section (Page 111).

MODELS SB-301/401 MODIFICATIONS

Refer to Pictorial 7-1 for the following steps.

- () Unsolder, remove, and discard the red hookup wire between lugs 2 and 5 of terminal strip AC.
- () Prepare the following lengths of hookup wire.

White-orange	5-1/4"
Small red	4"
Small red	1-1/4"

- () Refer to Detail 7-1A and solder a male terminal to one end only of each of the wires prepared in the preceding step.

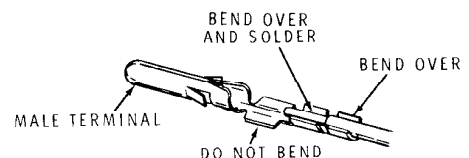

Detail 7-1A

NC
wi
ha
#9
the
mi
to
ha
Pa

Co
jus
the

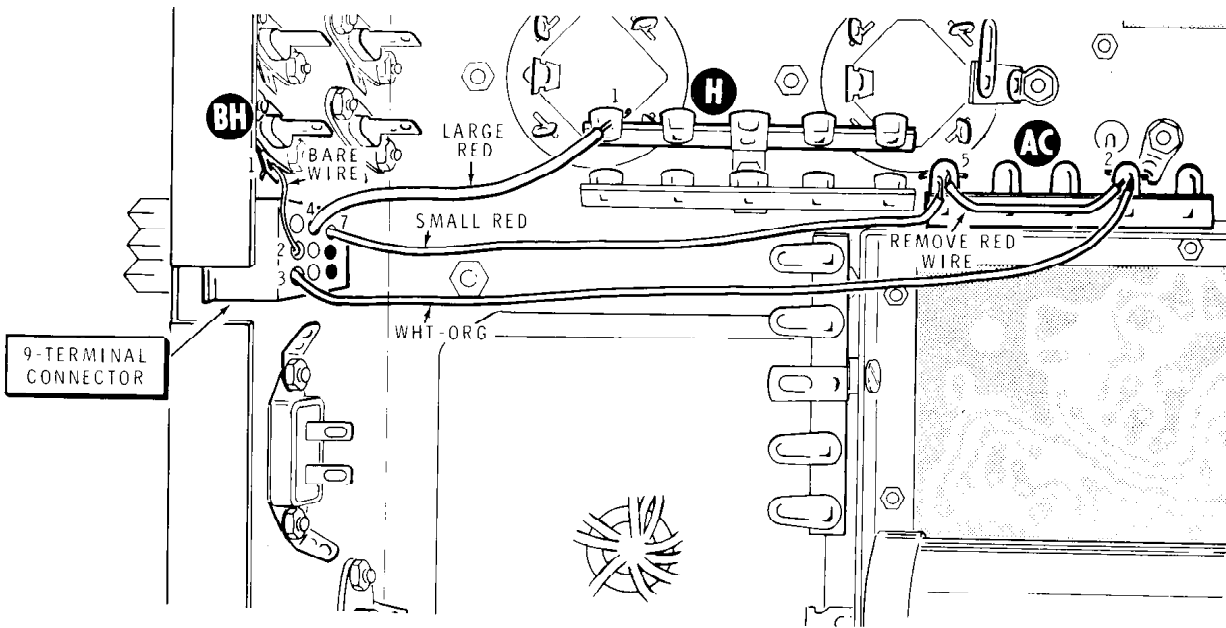

PICTORIAL 7-1

- () Prepare a 1-3/4" length of large red hookup wire,
- () Refer again to Detail 7-1A and cut one male terminal at a point between the "Bend-Over-and-Solder" and the "Bend-Over" portions. Then solder one end of the large red wire, to the "Bend-Over-and-Solder" portion of the terminal.
- () Cut a 1-1/4" length of small bare wire and solder a male terminal to one end.

- () Bare wire to lug 1 of phono socket BH.
- () Large red wire to lug 1 of terminal strip H.
- () Small red wire to lug 5 of terminal strip AC.
- () White-orange wire to lug 2 of terminal strip AC.

NOTE: In the following step you will connect wires to the 9-terminal chassis connector. Wires have previously been connected to holes #8 and #9. These holes are therefore blacked out in the illustration. Be SURE you insert the terminals in the correct holes, as they are difficult to remove. However, if you do make an error and have to withdraw a wire, refer to Figure 2 on Page 83.

- () Refer to Detail 7-1B and insert the wire terminals in the holes shown. Be careful to select the proper hole. Insert the terminals until the ears expand to prevent withdrawal, as shown in the inset drawing.

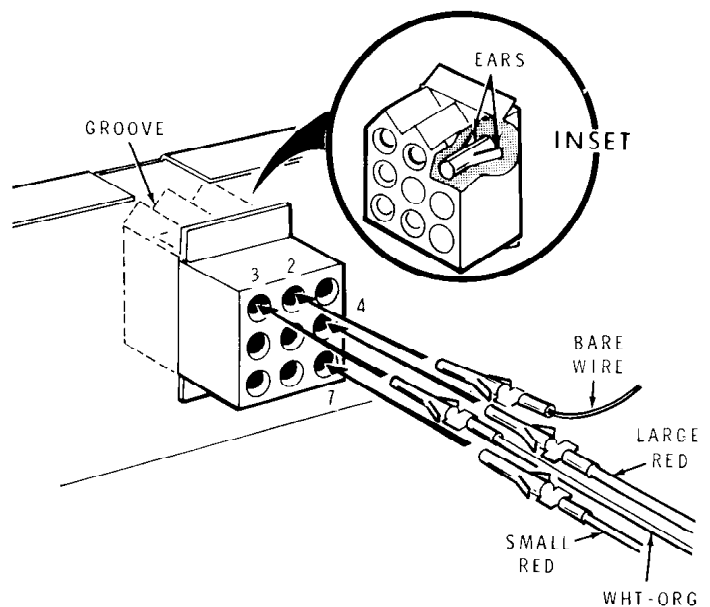

Detail 7 1B

Connect and solder the free ends of the wires just inserted in the connector as directed in the following steps:

Refer to Pictorial 7-2 for the following steps.

NOTE: For greater clarity, unnecessary wiring is omitted in this Pictorial. Pictorial 4-8 in the SB-401 Manual shows the other wiring in this area.

In the following steps, it may be easier to wind the link coil if approximately 3-1/4 turns are wound on a round object a little smaller than the L15 coil form (such as the smaller end of the nut starter). Then transfer the coil from the winding form to the L15 form. This will expand the coil, reduce the turns to three, and cause the turns to fit better.

- () Prepare a 5-1/4" length of red hookup wire:
- () Refer to Detail 7-2A and wind a 3-turn coil on coil form L15 at CU. Be SURE to wind this coil in the same direction as L15. Space the coils 1/4" apart. Form the coil leads as shown.

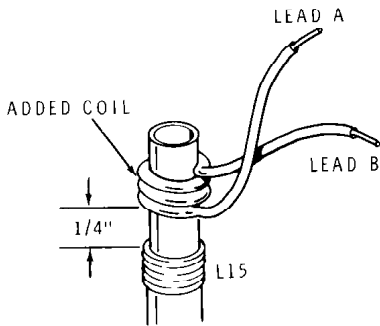

Detail 7-2A

- () Refer to Detail 7-2B and mount a 2-lug miniature terminal strip on the mounting screw for the spring clip (bearing on the switch shaft) near coil CU. Use a 3-48 nut. Remove and discard one #3 lockwasher and reposition the remaining lockwasher as shown.
- () Connect lead B of the coil (Detail 7-2A) to lug 2 (NS) of the terminal strip.

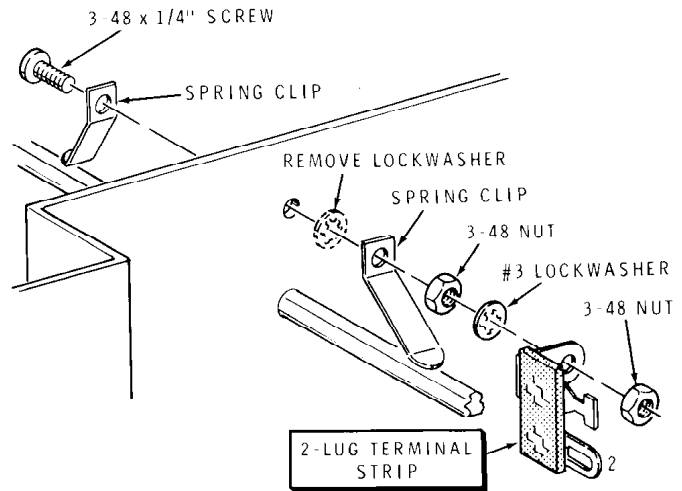

Detail 7-2B

- () Connect lead A of the coil to lug 1 (NS) of the terminal strip.
- () Refer to Detail 7-2C and prepare an 8-1/4" length of small coaxial cable.

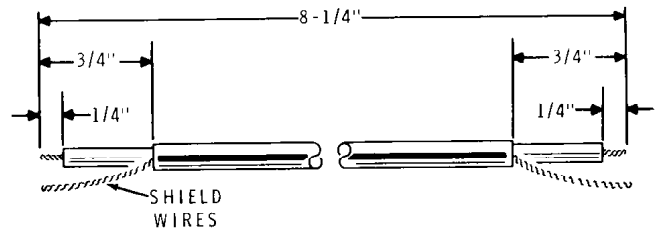

Detail 7-2C

- () At one end of the coaxial cable, connect the center conductor to lug 2 (S-2) and the shield wires to lug 1 (S-2) of the 2-lug terminal strip.
- () At the other end of the coaxial cable, connect the center conductor to lug 2 (S-1) and the shield wires to lug 1 (S-1) of phono socket BY as shown in the Pictorial.

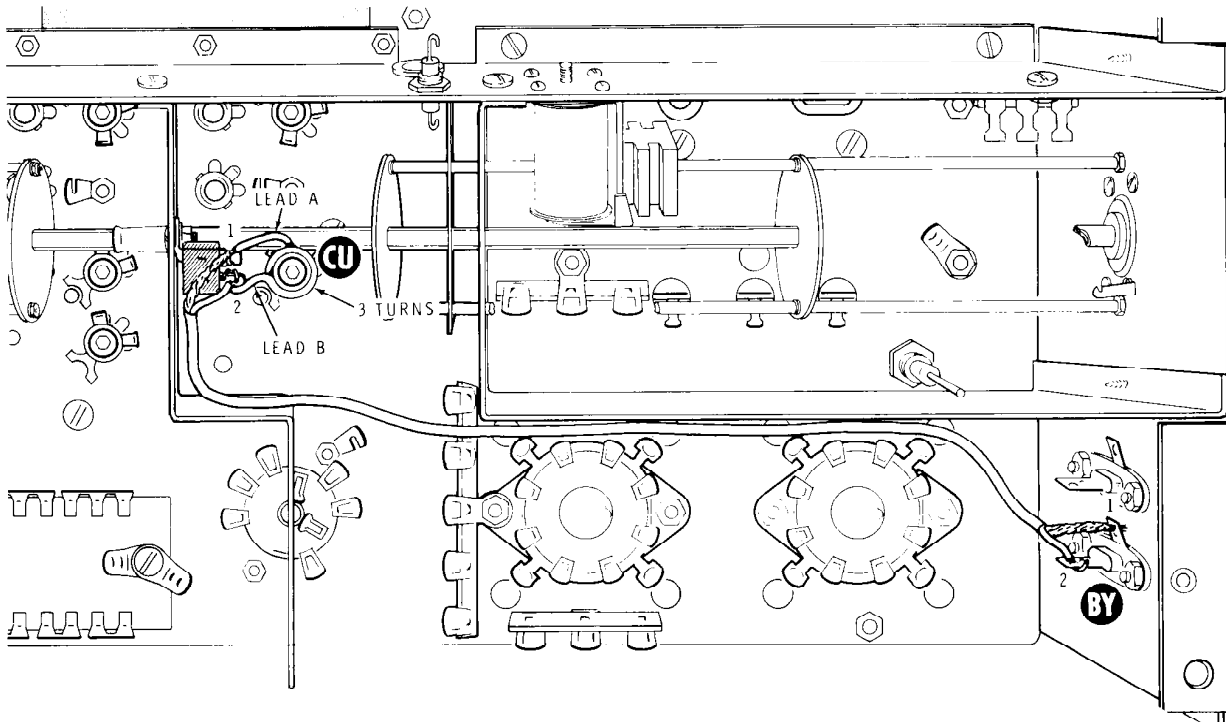

PICTORIAL 7-2

This completes the chassis modifications. Refer to Figure 7-1 for a revised schematic which incorporates the foregoing wiring changes. Figure 7-2 (fold-out from Page 110) shows how to interconnect the Transverter and the SB-301/SB-401 combination. If you also use the Model SB-200 Linear Amplifier, refer to Figure 7-3 (fold-out from Page 111).

Interconnecting cables are required between the Receiver, Transmitter, and the Transverter, as well as to the Linear Amplifier, if it is used. The additional lines required are shown by solid lines in Figures 7-2 and 7-3, and the previously existing connections by dashed lines. Cable and plugs are not furnished for SB-200 connections; these will be prepared in the following steps.

- () Cut the interconnecting cables to length according to the physical arrangement of your individual station.
- () Except for the AGC line between the two cable sockets, install a phono plug on each end of each cable (Pictorial 2-16 on Page 74).

Refer to the following steps if you use the SB-200 Linear Amplifier. In these steps, you will connect the ALC line from the Transmitter to the ALC line from the Linear Amplifier at the Transverter's ALC phono plug.

- () Unsolder and remove the phono plug from one end of the ALC line from the Transmitter.
- () Cut a coaxial cable to reach between the Transverter and the Linear Amplifier ALC connectors.

Refer to Pictorial 7-3 for the following steps.

- () As shown in Part A, prepare the end of the cable from which the phono plug was removed.
- () In like manner, prepare one end of the coaxial line which will run between the ALC connector of the SB-500 and the Linear Amplifier.
- () Refer to Part B of the Pictorial and twist the two ALC line center conductors tightly together; melt a small amount of solder on the wires to hold them together.
- () Similarly, twist together and solder the shield wires.
- () Reinstall the removed phono plug on the two joined coaxial cables as shown in Part C of the Pictorial. Trim off excess center conductor and shield wires.
- () Refer back to Pictorial 2-16 on Page 74 and install a phono plug for the Linear Amplifier ALC connection on the free end of the coaxial cable.

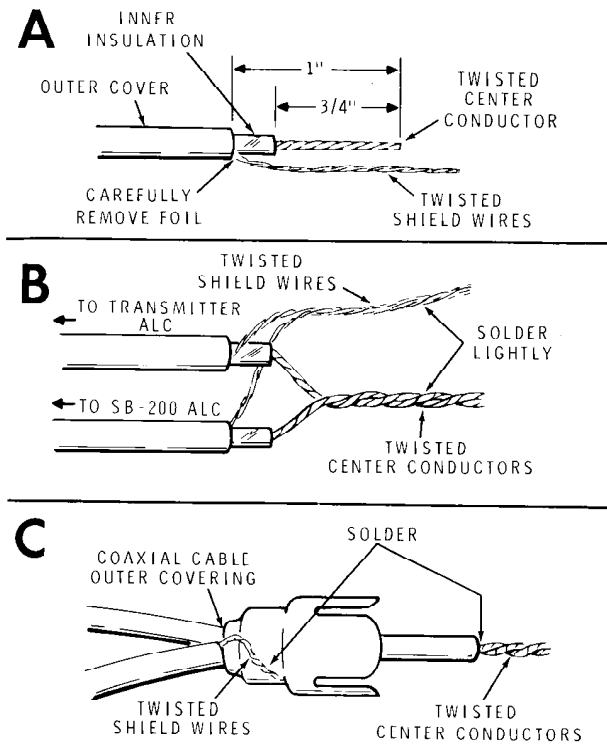

PICTORIAL 7-3

Proceed to the Alignment section.

MOBILE MOUNT MODIFICATIONS

When a Heath Transceiver has been modified for use with this Transverter, you can use it with the Heath Mobile Mounting Bracket. You may have to provide a clearance hole in the Mounting Bracket for the Screen Jumper Connector.

CAUTION: BEFORE APPLYING POWER TO THE TRANSVERTER, NOTE THAT LETHAL VOLTAGES ARE PRESENT BOTH ABOVE AND BELOW THE CHASSIS. DO NOT TOUCH ANY VOLTAGE POINTS WITH YOUR HANDS. USE WELL INSULATED TOOLS FOR ANY ADJUSTMENTS.

TO REDUCE SHOCK HAZARD, CONNECT A LEAD FROM A GOOD EARTH GROUND TO THE STATION EQUIPMENT.

Keep well in mind that whenever the low band equipment is turned ON, full plate voltage is applied to the final tank circuit of the Transverter, even though it is turned off.

ALIGNMENT

NOTE: The lower frequency equipment used as the tuned IF may be referred to in the following pages as the "LB" (low band) equipment.

To properly align the Transverter it must be connected to the LB (6 or 10 meter) amateur equipment with which it will be used. Connection diagrams are included in this Manual with the modification instructions for each model of Heath equipment.

Diagrams are also included to show the interconnections when the SB-200 Linear Amplifier is used. However, the cables and connectors required for this application are not furnished and should be procured locally.

The following equipment is required to align the Transverter:

1. Your complete low band station.
2. A dummy load such as the Heathkit Antenna. Do not use light bulbs for a dummy antenna, as their impedance, and therefore the load, varies with current and frequency.
3. A VTVM (vacuum tube voltmeter) with an 11 megohm input impedance. Although a VOM can possibly be used, the lower input impedance common to these instruments may load the grid circuits to the extent that meter indications are less apparent.

Refer to Figures 1-1 and 1-2 (fold-out from Page 78) for the location of parts on the Transverter chassis.

- () Interconnect the Transverter with your LB equipment, using the 8-wire cable and the coaxial cables previously prepared. Refer to the interconnection diagram included in the Modification section pertaining to your Heath equipment.
- () Place the LB equipment and the Transverter back-to-back and separate them by the full length of the 8-wire cable.



RECEIVER ALIGNMENT

CRYSTAL CALIBRATOR

The calibrator of the Transverter must be aligned against a signal known to be on 1 MHz, or a multiple thereof. As there are no standard frequency signals within the range of the Transverter, its calibrator must be aligned with a harmonic of the crystal calibrator in the LB equipment (recheck the accuracy of the LB calibrator first). Follow the procedure for the LB equipment.

- () Set the Calibrator Trimmer capacitor as shown in Figure 1-1.
- () Turn on the LB and Transverter equipment. Turn the Transverter METER switch to CAL. Let the equipment warm up for five minutes. CAUTION: If you observe any component overheating (usually a resistor) during the warmup period, note the part, turn the equipment OFF immediately, and refer to the In Case of Difficulty section of this manual.
- () Set the LB receiver to the low frequency end of its range 28.0 MHz for a 10-meter IF or 50.0 MHz for a 6-meter IF. Locate the HB (SB-500) calibrator signal by tuning around this frequency. There will be several signals present; use the loudest.
- () Turn on the LB calibrator. You should now hear a heterodyne, or beat note, which is the difference frequency between the Transverter and LB crystal calibrator signals.
- () Adjust the Transverter Calibrator Trimmer capacitor to bring the Transverter crystal calibrator signal into zero beat with the LB calibrator signal. Use an insulated screwdriver (if available) to eliminate hand capacity, which will change the frequency of the calibrator signal a small amount.
- () Turn both calibrators off.

This completes alignment of the crystal calibrator

COIL ALIGNMENT

- () Set the LB equipment controls as follows:

RF GAIN	Fully clockwise
AF GAIN	Suitable
BAND	28.0 or 50.0 MHz
PRESELECTOR	Peak on noise
FUNCTION	PTT
METER	ALC
OSC. MODE (SB-110 only)	LMO
FREQ. CONTROL (SB-101, SB-102)	Locked normal
OTHER MODELS	Immaterial
MODE	LSB
MAIN TUNING	0 at left of scale
MIC CW LEVEL	Fully counter- clockwise

- () Set the Transverter controls as follows:

METER	REL PWR
FINAL	CCW
PRESELECTOR	CCW
OFF-ON	ON
OTHERS	Immaterial

- () Let both pieces of equipment warm up for a few minutes.
- () Connect a VTVM to the Transverter so it will read negative volts at TP (test point #1) on the underside of the chassis (see Figure 1-2 fold-out from Page 78).
- () Refer to Figure 8-1 and insert the alignment tool in coil L8. Be sure the hexagonal end of the tool engages the hexagonal hole in the coil. Rotate the tool in both directions until you secure a peak indication on the VTVM, which should be more than -1.5 VDC. Then turn the coil slug 1/8 turn counterclockwise.
- () Move the VTVM probe to TP#2 on the receiver circuit board (See Figure 1-1).
- () Adjust coil L9 for a peak indication on the VTVM; the peak should be at approximately -1.0 VDC.

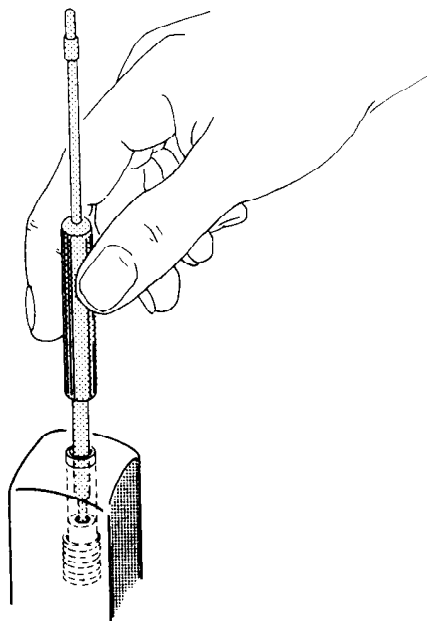

Figure 8-1

- () Disconnect the VTVM.
- () Turn the Transverter METER switch to CAL.
- () Tune for the loudest signal near 28 or 50 MHz. Then adjust the LB PRESELECTOR for maximum indication on the LB S meter, or for peak noise.
- () Place a small piece of tape temporarily over the opening in the coil shield of L2 (the neutralizing coil) to prevent adjustment of this coil at this time.
- () Adjust coils L1, L3, L4, L5, L6, and L7 for maximum LB S meter indication. Coils L6 and L7 (not used with 28.0 MHz IF) may provide little or no peaking indication.
- () Repeat the above step.

- () Turn the Transverter PRESELECTOR fully clockwise.

NOTE: Oscillation is indicated by squeals or "birdies" as the receiver dial is turned, or by abrupt movements of the S meter needle instead of smooth increases and decreases as you tune slowly through a signal. In the presence of a strong oscillation, the S meter may be "pinned" and the audio output may be reduced by the exceptionally strong AVC action.

- () If the meter indicates oscillation, remove the tape and turn the slug in coil L2 counterclockwise until the oscillator stops. Then replace the piece of tape on L2.
- () Return the PRESELECTOR counterclockwise and repeak all coils except L2.
- () Turn off the Transverter calibrator.
- () Turn on the LB calibrator and set the LB Main Tuning dial at 28 MHz or 50 MHz.
- () Turn the LB calibrator off.
- () Turn on the Transverter calibrator.
- () Adjust Transverter oscillator coil L8 until its signal is zero beat at the dial setting of the LB equipment.
- () Turn off the Transverter calibrator, the Transverter, and the LB equipment.
- () Remove and discard the piece of tape from the L2 coil shield.

This completes alignment of the receiver.

TRANSMITTER ALIGNMENT

Before beginning alignment of the transmitter, check to make sure that:

1. The Transverter and LB equipment are interconnected in accordance with the diagram in the modification section for your Heath equipment.
 2. The ends of the small red and large red wires are adequately taped.
 3. A Heathkit Antenna, or other dummy load, is connected to the LB equipment.
- () Tune up the LB equipment for operation at 28 MHz or 50 MHz. Then set the FUNCTION switch at VOX or PTT (on SB-110), the MODE switch at LSB, and the MIC CW LEVEL fully counterclockwise.
- () Refer to Figure 1-1 (fold-out from Page 78) and position the notches of trimmer capacitors C236 and C245 as shown.
- () Turn the Transverter on its side in such a manner that you have access to both the top and bottom of the chassis.

WARNING: After you disconnect the dummy load from the LB equipment in the following step, do not turn the LB equipment ON by itself unless a suitable load is connected to its output.

- () Disconnect the dummy load from the LB equipment and connect it to the RF output of the Transverter.

COIL AND TRIMMER ALIGNMENT

NOTE: To "tack solder" a wire, as in the following step, lay the bared end of the wire on the solder lug and solder it with a small amount of solder. Do not bend the wire around the lug or push it through the hole in the lug, as it will be removed later.

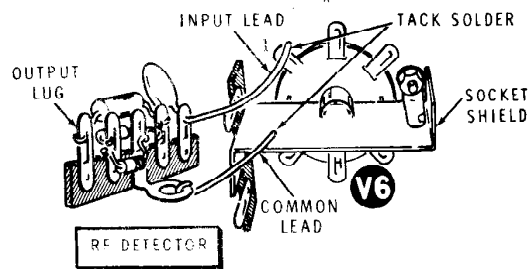

Figure 8-2

- () Refer to Figure 8-2 and tack solder the input lead of the RF detector to lug 3 of tube socket V6 in the Transverter. Tack solder the common lead to the socket shield. Make sure these leads do not touch anything else.
- () Connect your VTVM to the output lug of the RF detector so it will read -DC volts on the 1.5 volt range. Increase the range setting as necessary during the alignment process.
- () Turn ON the Transverter and let it warm up for a few minutes.
- () Peak coil L10 (on the bottom of the Transverter chassis) for a peak voltage. Use the shorter end of the alignment tool provided. In no case should you turn any coil core so far that it leaves the coil form.
- () Turn the Transverter OFF.
- () Disconnect the VTVM and remove the RF detector.
- () Tack solder the input lead of the RF detector to the midpoint of coil L14 at its connection with the 100 Ω (brown-black-brown) resistor. Tack solder the common lead to the adjacent shield.
- () Reconnect the VTVM to the RF detector.
- () Turn the Transverter DRIVER knob to the ten o'clock position. Make a small mark on the panel so the knob may be returned to this position.

- () Turn ON both the Transverter and the LB equipment. Turn the MODE switch to TUNE, turn the MIC CW LEVEL control clockwise for a small VTVM indication, and peak coils L11 and L12.
 - () Peak trimmer capacitor C236.
 - () Return the MODE switch to LSB and turn OFF all equipment.
 - () Disconnect the VTVM and the RF detector.
 - () Discharge the bias voltage supply by grounding lug 3 of control N (Figure 1-2 fold-out from Page 78) to the chassis with a screwdriver blade.
 - () Temporarily tack solder an insulated wire as a test jumper from lug 3 of control N on the rear apron (BIAS ADJ) to lug 1 of terminal strip AR.
 - () Set the VTVM to the -150 VDC range and connect it to test point #3 (Figure 1-2).
 - () Turn ON all equipment.
 - () Refer to Figure 1-1 (fold-out from Page 78) and set BIAS ADJ control fully clockwise as viewed from the rear.
 - () Turn the MODE switch to TUNE, advance the CW LEVEL control for an indication on the VTVM and peak the LB DRIVER.
 - () Peak Transverter trimmer capacitors C236 and C245 on top of the chassis. Use an alignment tool or an insulated screwdriver, if one is available. Record the voltage reading.
 - () Turn the LB BAND switch to its highest frequency range. If you have installed a crystal to extend the range of the SB-110 Transceiver to a higher frequency, such as 54 MHz, then turn the band switch to that position.
 - () Peak the LB and Transverter DRIVER capacitors.
- CAUTION: In the following steps, do not allow coil L14 to touch link coil L15, or the final tubes may be seriously damaged.
- () Adjust the coupling between coil L14 and link coil L15 for maximum voltage reading on the VTVM. Use the alignment tool to move link coil L14 toward or away from the chassis in small increments. After each adjustment of the link coil, repeak the DRIVER for maximum VTVM reading.
 - () Use the shorter end of the alignment tool to stretch or compress the turns of L13 and L14 for maximum reading on the VTVM. Record the voltage reading.
 - () Compare the peak voltage readings at the high and low frequencies covered by the Transverter.
 - () Turn one of the trimmer capacitors a very small amount and remember the direction of rotation. Again record the voltage reading.
 - () Turn the BAND switch to the lowest frequency range. Reposition the Transverter DRIVER at 10 o'clock, and peak the LB DRIVER. Note the voltage reading.
- If the difference between high and low frequency voltage readings is less than before, repeat the 4 preceding steps until you have reduced the difference in voltages as much as possible. If the voltage difference is greater, turn the trimmer capacitors in the opposite direction in very small increments and adjust for minimum difference voltage. Note that, in any event, both the high and low frequency voltage readings should be ~~at least~~ ^{at least} -60 VDC or more.
- () Turn OFF all equipment. Turn the MIC CW LEVEL fully counterclockwise, and disconnect the VTVM.

- () Refer to Figure 8-3 and tack solder the input lead of the RF detector to the center conductor pin of the coaxial antenna fitting. Tack solder the common lead to pin 1 of 2-lug terminal strip DL.

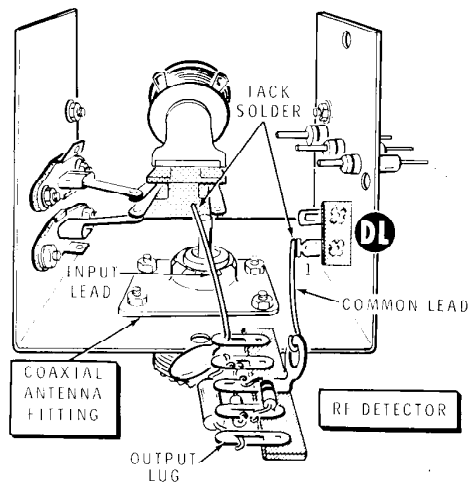

Figure 8-3

- () Keep the LB equipment on TUNE and turn the Transverter FINAL knob index mark back and forth around the 10 o'clock position while watching the VTVM. If the peak voltage occurs with the knob index mark between 9:30 and 11 o'clock, no adjustment action is required (See Figure 8-4). If the peak voltage is observed earlier than the 9:30 o'clock position, more inductance is required. If the peak voltage is observed later than the 11 o'clock position, less inductance is required. Perform the appropriate group of steps following.

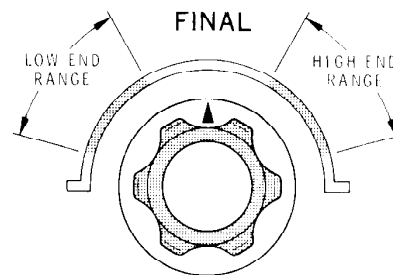

Figure 8-4

- () Set the VTVM to read on the -1.5 VDC range and connect it to the output of the RF detector.

FINAL FREQUENCY ADJUSTMENT

- () Turn both the Transverter and the LB equipment ON.
- () Tune the LB equipment to the lowest frequency position covered by the transverter.
- () Peak the Transverter DRIVER.
- () Turn the MIC CW LEVEL fully counter-clockwise. Then turn it back clockwise for a small but significant indication on the VTVM.

1. More inductance is secured by performing the following steps:
 - () Refer to Detail 2-4E and unsolder the two ceramic anode caps.
 - () Resolder the two anode caps 1/8" farther out on the plate tabs. This will provide additional tab inductance and a lower frequency at the same capacitor setting.
2. Less inductance is secured by performing the following steps:
 - () Refer to Detail 2-4E (Page 37) and unsolder and remove the two ceramic anode caps.
 - () Clip off and discard 1/8" from the end of each plate tab.
 - () Resolder the two anode caps in the same relative position on the shortened tabs.

NEUTRALIZING

- () Turn both the Transverter and the LB equipment ON.
- () Set the BAND switch at its highest frequency position.
- () Turn LB equipment to TUNE.
- () Advance the MIC CW LEVEL for a significant reading.
- () Peak both DRIVER controls and the Transverter FINAL and LOADING.
- () Advance the MIC CW LEVEL for maximum indication.

NEUTRALIZATION

- () Slip the large end of the nut starter over the end of one of the insulated neutralizing wires (beside each final tube) and adjust this wire (by bending it) for minimum meter indication.
- () Repeat the procedure with the other neutralizing wire.
- () Repeak both DRIVER controls and the Transverter FINAL. Then readjust both neutralizing wires to make sure you have the lowest meter reading obtainable.
- () Turn OFF all equipment and turn the MIC CW LEVEL fully counterclockwise.
- () Disconnect the VTVM and remove the RF detector.
- () Remove the test jumper between control N and terminal strip AR.
- () Connect your VTVM to read negative voltage at TP #3 (Figure 1-2) on the Transverter chassis.

- () On the LB equipment, turn the MIC CW LEVEL fully counterclockwise and set the MODE switch at TUNE.
- () Turn ON all equipment.
- () Refer to Figure 1-1 and set the BIAS ADJ control for a VTVM reading of -50 VDC.
- () Turn OFF all equipment.

FINAL PLATE AND SCREW VOLTAGE**WARNING**

Whenever the LB equipment is turned on after the large red wire is connected in the following steps, full plate voltage will be present on the final tank circuit of the Transverter, **EVEN IF THE TRANSVERTER IS TURNED OFF.**

- () Make sure both the Transverter and the LB equipment are turned OFF.
- () Untape the end of the small red wire coming from relay BH under the chassis (Pictorial 2-8). Connect this wire to feedthrough capacitor CE (S-1). This wire carries the screen voltage for the final tubes.

NOTE: After removing the tape in the following step, touch the bare end of the wire to the chassis to insure that the high voltage filter capacitors are fully discharged.

- () Untape the end of the large red wire coming from BO#8 (Pictorial 2-7). Connect this wire (plate voltage) to feedthrough capacitor CD (S-1). After the joint has cooled, slide the clear sleeving down over the joint and the feedthrough capacitor.

CAUTIONS:

1. An antenna or dummy load **MUST BE** connected to the Transverter whenever drive is applied from the LB unit.
 2. An antenna or dummy load **MUST BE** connected to the LB unit whenever it has RF output and the Transverter is OFF.
 3. Switch the Transverter ON or OFF only when the LB unit is in STANDBY or the MIC CW LEVEL is fully counterclockwise.
 4. Turn all equipment OFF before connecting or disconnecting a meter probe when measuring high voltages.
- () Set your VTVM to read 1000 VDC or more.
 - () Connect the VTVM common lead to the chassis and the positive probe to the final RF choke (see Figure 1-2 fold-out from Page 78).
 - () Turn ON the Transverter and the LB equipment. Then measure the plate voltage to the final tubes at the final RF choke. **CAUTION: High voltage!** The voltage should be the same as that normally present at the plates of the final tubes in the LB equipment.
 - () Turn LB equipment to TUNE with the CW LEVEL fully counterclockwise.
 - () Measure the screen voltage for the final tubes at power relay lug #10 (see Figure 1-2 fold-out from Page 78). This should be +200 to +225 VDC.
 - () Turn OFF all equipment and disconnect the VTVM.
 - () Refer to Figure 1-2 (fold-out from Page 78). Make sure that coils L16 and L17 are parallel to each other and are spaced 1/8" apart. Use the shorter shaft of the alignment tool as a spacing gauge.
 - () Gather the cables together by wrapping a couple of turns of tape around the entire group of interconnecting cables at equally-spaced intervals. Leave 6" untaped at each end of the 8-wire cable.

This completes the Alignment section.

OPERATION

CONTROL FUNCTIONS

FRONT PANEL CONTROLS

Refer to Figure 10-1 for control locations.

Meter Switch

PLATE. Indicate plate current up to 500 mA.

REL PWR. Scale from 0 through 10. Used for comparative measurements of output power.

The scale figures do not refer to any specific power level.

CAL. Turns on the 1 MHz calibration oscillator.

Final

Tunes the final tank circuit to resonance.

Off-On

1. Turns the Transverter on and off.
2. Switches screen voltage to the final tubes of either the Transverter or the LB equipment.
3. Controls antenna connections and relay switching.

Preselector

Tunes receiver circuits to the incoming signal.

Loading

Adjusts the coupling between the final tank circuit and the transmission line.

Driver

Tunes transmitter circuits to the frequency of the outgoing signal.

CHASSIS CONTROLS

Refer to Figure 1-1 for control locations.

Rel Pwr Adj

Meter calibration adjustment (when the METER SWITCH is in the REL PWR position).

Bias Adj

Adjustment for the bias voltage applied to the grids of the final amplifier tubes.

Calibrator Trimmer

Adjusts the calibration oscillator frequency.

GENERAL INFORMATION

Before you operate the Transverter, the LB equipment should be tuned up in the usual manner. Then, after the Transverter is turned ON, the LB equipment is operated as a tuned IF. Bear in mind that the LB FINAL and LOAD controls will now have no effect, since the screen voltage has been removed from the final tubes. Other controls operate in the normal manner.

Transmitting and receiving frequencies are confined to those converted frequencies covered by the BAND switch position on the LB equipment. For example, to operate between 144 and 144.5 MHz, the BAND switch on the SB-110 Transceiver must be set at 50.0 MHz, or at 28.0 MHz with other equipment used.

Both the Transverter and the SB-640 External LMO may be used simultaneously with the appropriate Transceiver. The addition of the Transverter to an existing SB-101/102 and SB-640 station will not change the Frequency Considerations as explained in the SB-640 Manual.

If a Heath amplifier is used (such as the Model SB-200 Linear Amplifier), it will be bypassed when the Transverter switch is ON and the station is operating on 2-meters. The amplifier will operate in the normal way when the Transverter switch is OFF. For connection diagrams pertaining to the SB-200 Linear Amplifier, refer to the modification section of this Manual that pertains to your Heath equipment.

All frequency selection is done with the LB equipment; but the appropriate transmitting and receiving controls on both the Transverter and the LB equipment should be repeated as the operating frequency is changed from the tuneup frequency. Use the Transverter meter in the REL PWR position to peak transmitted signals, and the LB meter in the ALC (S meter) position to peak received signals.

There is no inversion of sidebands in the SB-500. The transmitted signal will be on the sideband selected in the LB equipment.

READING THE METER

Refer to Figure 10-2.

The 0 to 10 scale on the meter is used with the METER switch in the REL PWR position to indicate the relative degree of output. Interpolate for numbers not shown.

The 0 to 500 scale is used when the METER switch is in the PLATE position. It indicates the milliamperes of plate current being drawn by the final tubes.

Disregard the letters "ALC."

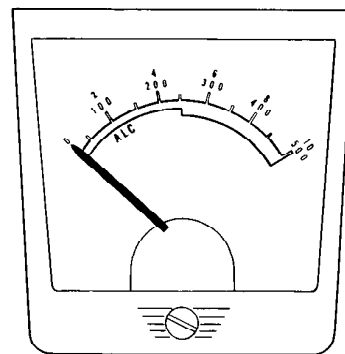

Figure 10-2

TUNE-UP PROCEDURE

NOTE: Before starting to tune up, make sure the Transverter is connected as shown in the interconnection diagram pertaining to your particular model of Heath amateur equipment (see Equipment Modification, Page 83).

CAUTION: Do not allow the final amplifier to operate in the TUNE, or key down, condition for longer than ten seconds continuously. Then allow at least thirty seconds cooling time.

SSB TUNE-UP

- () Preset the Transverter controls as follows:

METER switch	REL PWR
FINAL	Counterclockwise
OFF-ON	OFF
PRESELECTOR	Counterclockwise
LOADING	50 Ω
DRIVER	10 o'clock
REL PWR ADJ	Center of rotation

- () Connect a dummy load to the LB equipment.
- () Turn On the LB equipment, and let it warm up for several minutes.
- () Tune up the LB equipment to the low frequency end of its range (50.0 MHz or 28.0 MHz).
- () Turn OFF the LB equipment.
- () Disconnect the dummy load from the LB equipment and connect it to the RF output of the Transverter.
- () Set the LB equipment controls as follows:

METER	ALC
FUNCTION	VOX
MODE	LSB
MIC CW LEVEL	Counterclockwise

- () Turn the Transverter METER switch to CAL.
- () Turn the equipment ON.

- () Tune the LB receiver around the nearest MHz mark on its dial for the strongest signal, and set the hair line over the dial "0" mark.
- () Peak the Transverter and LB PRESELECTORS for the loudest signal.
- () Turn the Transverter meter switch to PLATE.
- () Turn the LB equipment to TUNE with the MIC CW LEVEL control fully counterclockwise.
- () Carefully set the BIAS ADJ control for a plate current of 50 mA.
- () Turn the meter switch to REL PWR.
- () Rotate the MIC CW LEVEL clockwise for a small upward indication on the Transverter meter. Quickly adjust the Transverter FINAL and DRIVER, and the LB DRIVER, controls for maximum meter indication. Then peak the Transverter LOADING control, and turn the MODE switch to LSB. Repeat for maximum indication.
- () Turn the MIC CW LEVEL fully counterclockwise and turn the MODE switch to LSB (or USB) or the FUNCTION switch to STANDBY, as appropriate.

NOTE: The following step will usually apply to the initial tune-up only.

- () With one hand, insert a screwdriver into the REL PWR ADJ control on top of the chassis. With the other hand, turn the MODE switch to TUNE, and then rotate the MIC CW LEVEL control clockwise just to the point where further rotation does not result in additional meter needle movement. Quickly adjust the REL PWR ADJ control to 10 (full scale). Then turn the MODE switch to USB.

- () Turn the MIC CW LEVEL fully counter-clockwise. Speak into the microphone and rotate the MIC CW LEVEL clockwise just to the point where the LB meter (set on ALC) kicks upward about 1/8" with speech. This indicates full output. Additional rotation of the control will NOT increase the output and may degrade the signal.

Peak plate current to the final tubes of the Transverter should not exceed 240 mA with full single tone drive (MODE switch at TUNE) applied from the LB equipment. With the LB MODE switch at LSB or USB and the LB FUNCTION switch at PTT, the resting plate current of the Transverter will be approximately 50 mA when the PTT switch is depressed.

With the LB MODE switch at LSB or USB and the FUNCTION switch at VOX, the Transverter meter (at PLATE) will indicate peaks of approximately 100 mA with average speech. Under the same conditions at REL PWR the meter will fluctuate from 2 to 3 on the upper scale with occasional voice peaks to 4 or 5 (midscale). With speech input, the actual plate current depends upon the voice characteristics of the operator, but is commonly considered to be in excess of twice the value indicated by the meter.

CW TUNING

- () Follow the preceding Tune-Up Procedure steps with the exception of the last step (MIC CW LEVEL adjustment for speech).
- () Plug a key into the KEY jack of the LB equipment.
- () Turn the MODE switch to CW. Make sure the FUNCTION switch is set to PTT or VOX.
- () Close the key and quickly advance the MIC CW LEVEL for a maximum or full scale meter reading on the Transverter. Then open the key. Leave the MIC CW LEVEL at this position and proceed with CW operation.

With the LB MODE switch at CW and the FUNCTION switch at VOX, the Transverter meter (at PLATE) should read 0 with the key open, and approximately 225 mA with the key closed. Turning the meter switch to REL PWR should result in full scale needle deflection with the key closed. CAUTION: Key-down time should not exceed 10 seconds. Then let the tubes cool for 30 seconds.

IN CASE OF DIFFICULTY

NOTE: Refer to the Kit Builders Guide for Service and Warranty information.

This section of the Manual describes what to do if the Transverter does not operate properly.

Circuit Board X-Ray Views (Page 145), and

Chassis Photographs (Page 146), have been furnished as an aid in locating components on the circuit boards and chassis.

Before you try to locate the cause of a trouble, be sure to check the control settings. Difficulties may also be due to improper connections.

GENERAL

The following paragraphs deal with the types of problems that may show up right after a kit is assembled. These difficulties are most likely to be caused by assembly errors or faulty soldering. The following checks will help you locate any error of this type.

1. Make a thorough visual check of the whole unit to be sure there are no obvious causes, such as unsoldered connections, burned or overheated parts, bare wires touching each other, obviously faulty solder connections, etc. Make sure there are no bits of solder, wire ends or other foreign matter lodged in the wiring. Carefully check all terminals that have several wires attached to make sure that all wires, especially the lower ones, are soldered.
2. Check all wires to make sure they are connected to the right places. Usually, it is quite helpful to have a friend help you make these checks. Someone not familiar with the unit may notice an error you have consistently overlooked.

3. Check the make sure that each of the tubes is in its proper location and that its filament is lighted.
4. Check all solder connections carefully to make sure they are bright and shiny.
5. Check all leads soldered to the foil side of the circuit boards. Be sure these leads do not protrude through the circuit board and short circuit component leads on the other side.
6. Check the values of resistors and capacitors to make sure the proper part is wired into the circuit in each position. It is sometimes easy to misread the third color band on a resistor. For example, if a 22 k Ω (red-red-orange) resistor were installed instead of a 220 k Ω (red-red-yellow) resistor, the circuit would not operate properly.

7. If, after careful checks, the trouble is still not located, check voltage readings against those shown in the Voltage Charts on Pages 129 and 130 and on the Schematic Diagram on Page 153. All voltage readings were taken with an 11 megohm input vacuum tube voltmeter.
8. If all of the checks listed above have been made and the trouble still is not located, it may be helpful to refer to the following Troubleshooting Chart.
9. A review of the Operation and Circuit Description sections of the Manual may indicate some condition overlooked.

TROUBLESHOOTING CHART

This section of the Manual is provided to help you locate the circuit causing the trouble if the Transverter does not function properly.

NOTE: The V number of a tube, when used in the following chart, refers both to the tube itself and to its associated circuitry.

RECEIVER AND POWER CIRCUITS

TROUBLE	POSSIBLE CAUSE
No power, pilot lamp does not light, no B+ voltage, no bias voltage.	<ol style="list-style-type: none"> A. Fuse blown or not installed. B. Defective ON-OFF switch. C. Power transformer wired incorrectly. D. Line cord not connected.
Pilot lamp lights, filaments light, but no B+ or bias voltage.	<ol style="list-style-type: none"> A. Rectifiers installed incorrectly or defective. B. Power transformer installed incorrectly or defective. C. Filter choke defective. D. Filter capacitor reversed. E. Broken or shorted feedthrough capacitor.
Bias and B+ voltage correct but no filament or pilot lamp.	<ol style="list-style-type: none"> A. Power transformer installed incorrectly or defective. B. V3 and V6 are series filaments. If one of these tubes is not installed, the other will not light. C. Wiring to calibrator bracket incorrect.
No regulated B+ voltage (+150 VDC).	<ol style="list-style-type: none"> A. Incorrect wiring of socket V5. B. Bad OA2 regulator tube. C. Resistor R202 or R203 open.
Regulated B+ voltage too high.	<ol style="list-style-type: none"> A. Pin 7 of V5 not grounded.

TROUBLE	POSSIBLE CAUSE
Regulated B+ voltage too low.	A. Bad OA2 regulator tube. B. Receiver circuit board incorrectly wired or shorted. C. Relay incorrectly wired.
No receiver B+, other voltages correct.	A. Relay defective, dirty contacts, or incorrectly wired.
No signal to receiver.	A. Connections to rear panel are incorrect. B. Cables are shorted or open. C. Low band receiver tuned to the wrong band. D. Antenna relay contacts dirty or open. E. Cables incorrectly installed at antenna relay.
Receiver oscillates when Preselector is tuned across band.	A. Neutralizing coil L2 incorrectly adjusted. B. Antenna not connected to Transverter. C. Preselector capacitor mounting hardware not tight.

TRANSMITTING CONVERTER (Relay Energized)

No voltage on screen lead of V9 and V10.	A. Relay incorrectly wired, dirty, or open contacts. B. Red wire to CE not soldered.
Incorrect bias voltages on V7, V8, V9, and V10 (too high).	A. Relay incorrectly wired, dirty, or open contacts. B. Bias network resistors incorrectly wired.
Incorrect bias voltage on V7, V8, V9, and V10 (too low).	A. Relay incorrectly wired, dirty, or open contacts. B. Bias circuit incorrectly wired. C. Jumper wire to lug 3 of N not removed.
No RF drive at cathode of V6.	A. Incorrect wiring changes in low band unit. B. Incorrect cable connection to rear panel. C. Cables open or shorted. D. Wrong type cable used.
No RF drive at grid of V7.	A. Tube V6 incorrectly wired. <i>athel</i> B. No oscillator injection at grid of V6. C. L11 and L12 incorrectly tuned.
Very little drive (or no drive) at grid of V8.	A. Incorrect bias on grid of V7. B. Plate circuit of V7 incorrectly adjusted. C. C238 cracked or broken.
Insufficient drive at final amplifier grids.	A. Incorrect bias or grid of V8. B. Plate circuit of V8 incorrectly adjusted. C. Insufficient coupling or overcoupling between link and plate coil of V8. D. No screen voltage on driver, check relay. E. C247 cracked or broken. F. Insufficient drive from LB equipment.

TROUBLE	POSSIBLE CAUSE
No RF output from final amplifier.	<ul style="list-style-type: none"> A. High voltage B+ not applied to plates. B. RF choke feed to plate tank open. C. Screen voltage not present on finals. Check relay. D. Bias incorrect on final amplifiers. E. Final and Loading controls not properly adjusted. F. Coaxial cable from final output link to antenna relay open or shorted. G. Antenna relay not operating properly. H. Final tubes wired incorrectly or defective. I. Coaxial cables incorrectly installed at antenna relay.
Relays will not energize when associated low band unit is switched to tune.	<ul style="list-style-type: none"> A. Check rear apron for proper connections. B. Relay coils defective. C. Relays wired incorrectly. D. Dirty contacts on <u>low band</u> unit relay. This is a shorting contact; it can be checked by shorting the relay terminal to ground with an insulated screwdriver.
Transmitter tends to be unstable.	<ul style="list-style-type: none"> A. Final not neutralized properly. B. Driver tuning capacitor mounting hardware loose. C. Defective feedthrough bypass capacitor. D. Coils L10 through L16 improperly aligned. E. Shield hardware not secure. F. Loose hardware at sockets or shields. G. Component lead dress is poor.
No heterodyne oscillator voltage at grid of V6 or cathode of V2.	<ul style="list-style-type: none"> A. Coaxial cable to these points shorted, open, or interchanged. B. Coil L10 improperly tuned or installed. C. Oscillator coils L8 and L9 improperly adjusted. D. Crystal defective. E. Component values wrong for oscillator frequency used. Check assembly manual for proper values. F. Tube V4 defective.
No calibrator signal.	<ul style="list-style-type: none"> A. Either tube V3 or V6 not installed or filaments wired incorrectly. B. Switch wired incorrectly. C. Coaxial cable shorted or open. D. Crystal defective or wired incorrectly. E. Calibrator not correctly adjusted.

METER CIRCUITS

TROUBLE	POSSIBLE CAUSE
No reading in Plate position.	A. Switch wired incorrectly. B. 750 Ω resistor installed incorrectly or wrong value. C. Meter defective or wired incorrectly. D. Cathode bypasses and resistors installed incorrectly or shorted. E. Jumper not removed from meter terminals.
No REL PWR reading.	A. Wiring to sensing network or adjustment control is incorrect. B. Diode defective or wired incorrectly. C. Adjustment control set wrong. D. Meter defective or wired incorrectly. E. Jumper not removed from meter terminals.

RECEIVER CIRCUIT BOARD VOLTAGE CHART (VIEWED FROM FOIL SIDE)

FRONT OF CHASSIS ➡

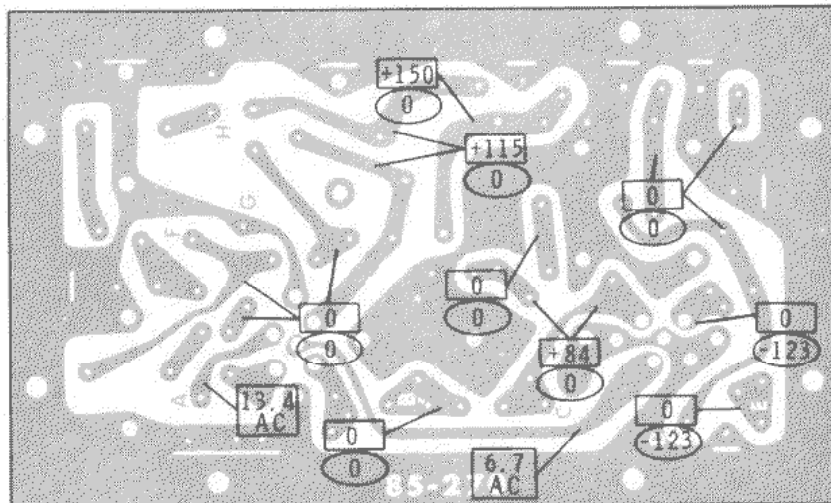

NOTES:

1. VOLTAGES MEASURED TO CHASSIS WITH A VOLTMETER HAVING INPUT IMPEDANCES OF 11 MEGOHMS FOR DC AND 1 MEGOHM FOR AC.
2. DC VOLTAGES ARE MARKED + OR- AS APPROPRIATE.
3. SYMBOLS:
 = VOLTAGE IN RECEIVE MODE.
 = VOLTAGE IN TRANSMIT MODE, MIKE-CW LEVEL FULLY COUNTERCLOCKWISE, KEY DOWN (TO CLOSE RELAYS).

Figure 11-1

RECEIVER CIRCUIT BOARD RESISTANCE CHART (VIEWED FROM FOIL SIDE)

FRONT OF CHASSIS ➡

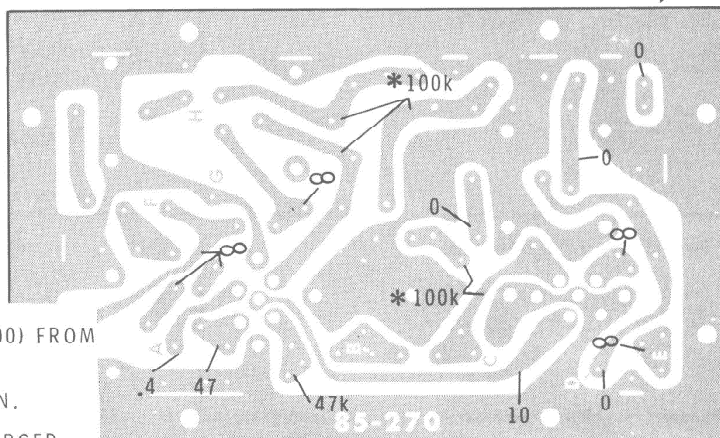

NOTES:

1. ALL RESISTANCES ARE IN OHMS (k=1000) FROM THE CHASSIS.
2. METER SWITCH AT REL. PWR. POSITION.
3. *- POWER SUPPLY CAPACITOR DISCHARGED.

Figure 11-2

OSCILLATOR CIRCUIT BOARD VOLTAGE CHART VIEWED FROM PRINTED (UPPER) SIDE

FRONT OF CHASSIS ⬆

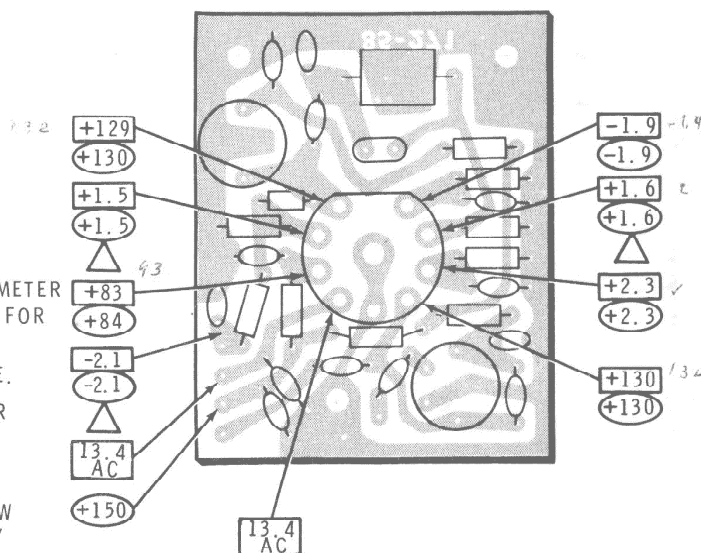

NOTES:

1. VOLTAGE MEASURED TO CHASSIS WITH A VOLTMETER HAVING AN INPUT IMPEDANCE OF 11 MEGOHMS FOR DC AND 1 MEGOHM FOR AC.
2. DC VOLTAGES MARKED + OR - AS APPROPRIATE.
3. △ = VOLTAGE WILL VARY WITH OSCILLATOR TUNING.
▭ = VOLTAGE IN RECEIVE MODE.
○ = VOLTAGE IN TRANSMIT MODE, MIKE-CW LEVEL FULLY COUNTERCLOCKWISE, KEY DOWN (TO CLOSE RELAYS).

Figure 11-3

OSCILLATOR CIRCUIT BOARD RESISTANCE CHART VIEWED FROM PRINTED (UPPER) SIDE

FRONT OF CHASSIS ↑

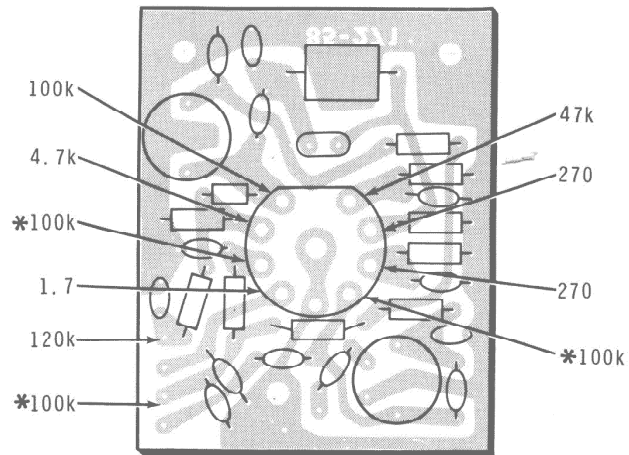

NOTES:

1. ALL RESISTANCES ARE IN OHMS (k=1000).
2. * = POWER SUPPLY CAPACITOR DISCHARGED.
3. METER SWITCH IN REL. PWR. POSITION.

Figure 11-4

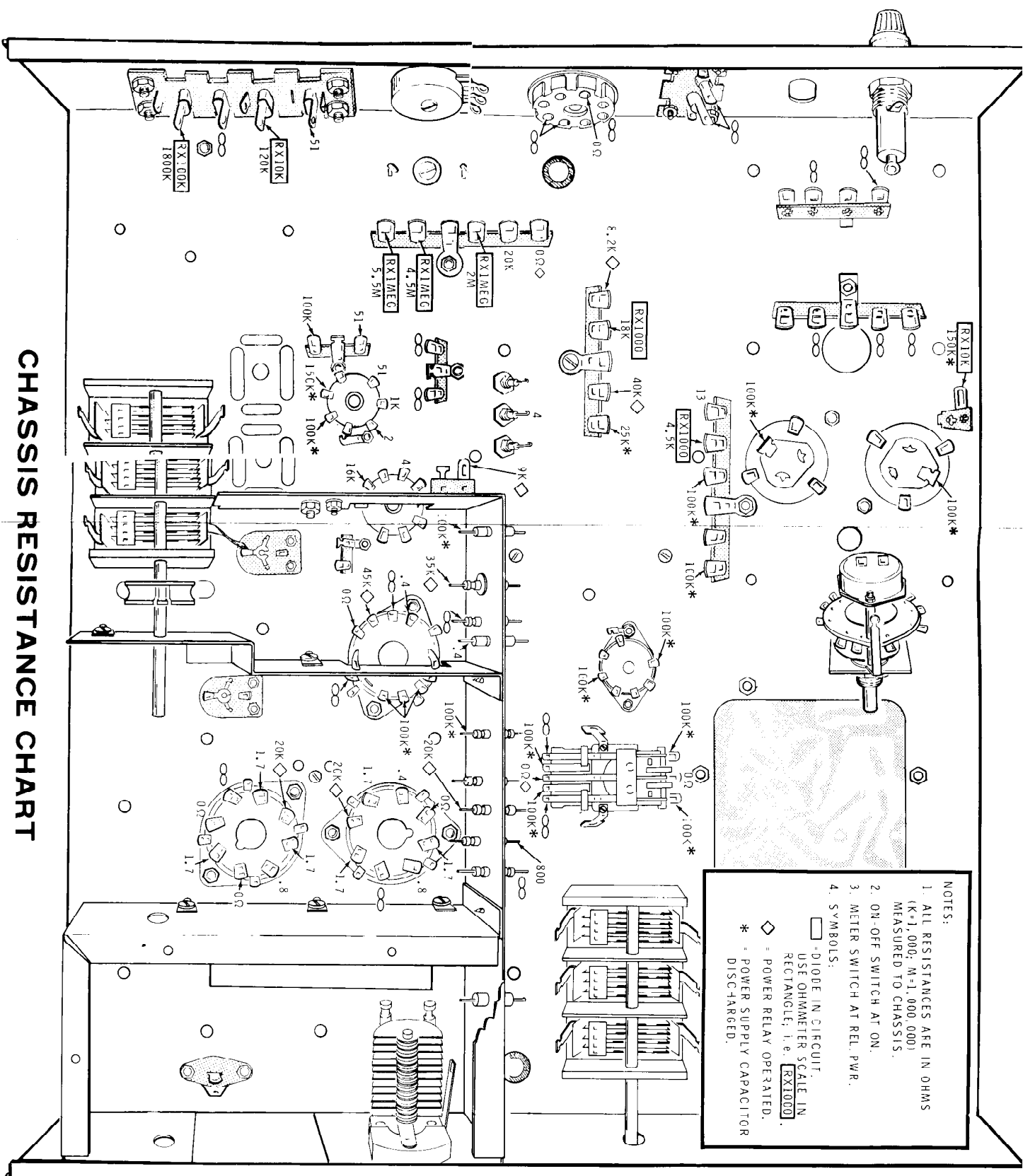

NOTES:

1. ALL RESISTANCES ARE IN OHMS (K = 1,000; M = 1,000,000) MEASURED TO CHASSIS.
2. ON-OFF SWITCH AT ON.
3. METER SWITCH AT REL. PWR.
4. SYMBOLS:
 - ▭ = DIODE IN CIRCUIT. USE OHMMETER SCALE IN RECTANGLE; i.e. [RX1000].
 - ◇ = POWER RELAY OPERATED.
 - * = POWER SUPPLY CAPACITOR DISCHARGED.

CHASSIS RESISTANCE CHART

FIGURE 11-6

SPECIFICATIONS

RECEIVER

Sensitivity.2 microvolt for 10 dB signal-plus-noise to noise ratio for SSB operation.
Spurious Response.	All are below .1 microvolt equivalent signal input, except at 145.390 MHz (50 MHz IF only).
Antenna Input Impedance.	50 Ω unbalanced.

TRANSMITTER

DC Power Input.	140 watts P.E.P.
Power Output.	50 watts (50% duty cycle).
Output Impedance.	50 Ω with less than 2:1 SWR.

GENERAL

Frequency Range.	144 to 148 MHz into 50-54 MHz or 28-32 MHz tuned IF (any 2 MHz segment).
Mode Of Operation.	SSB or CW only.
External Power:.	(1) 120/240 VAC, 50/60 Hz at 82 watts. (2) 700 to 800 VDC at 200 mA (from driving unit).
Fuse:.	3/4 ampere slow-blow for 120 VAC (formerly 3AG). 1/2 ampere slow-blow for 240 VAC.



Front Panel Controls.	Meter-Calibrate switch Final Tuning Off-On (Function) switch Preselector Final Loading Driver Tuning
Chassis Controls.	Relative Power Adjust Bias Adjust
Rear Apron Connectors.	RF Output ALC Linear Relay Relay Drive Power plug Low f Receiver Low f Antenna Fuseholder
Tube Complement.	6CB6 Transmitter mixer. 6CB6 Crystal calibrator. 6DS4 Receiver RF amplifier. 6DS4 Receiver mixer. 12GN7 Transmitter RF amplifier. 6146 Final amplifiers (2)*. 7059 Heterodyne oscillator-amplifier. 8156 RF driver. OA2 Voltage regulator. *Types 6146A or 6146B may be directly substituted.
Diode Complement.	5 Silicon diodes, 750 mA, 500 PIV: 3 in power supply, 2 in ALC. 1 Germanium diode, 1N191: REL PWR.
Cabinet Dimensions:	12-1/4" wide x 6-5/8" high x 13" deep.
Overall Dimensions*:	12-1/4" wide x 7-15/16" high x 14" deep.
Net Weight.	14-1/2 lbs.
*Dimensions with knobs and feet.	

The Heath Company reserves the right to discontinue instruments and to change specifications at any time without incurring any obligation to incorporate new features in instruments previously sold.

CIRCUIT DESCRIPTION

Refer to Figure 12-1, the Block Diagram, and to the Schematic (fold-out from Page 153) while reading the Circuit Description. Small sections of the Schematic are included in this description to make the circuits easier to follow.

Revised partial schematics which reflect the wiring changes in your LB equipment are included in the Equipment Modification section.

Letter-number designations for resistors, ca-

pacitors, and some other components, are placed in the following groups:

- 0- 99 Oscillator circuit board.
- 100-199 Receiver circuit board.
- 200 up Other parts.

Although the Transverter and LB equipment cover a band of frequencies (144-148 MHz), for simplicity in this description, 144 MHz will be used for the signal frequency and 50 MHz or 28 MHz for the LB intermediate frequencies.

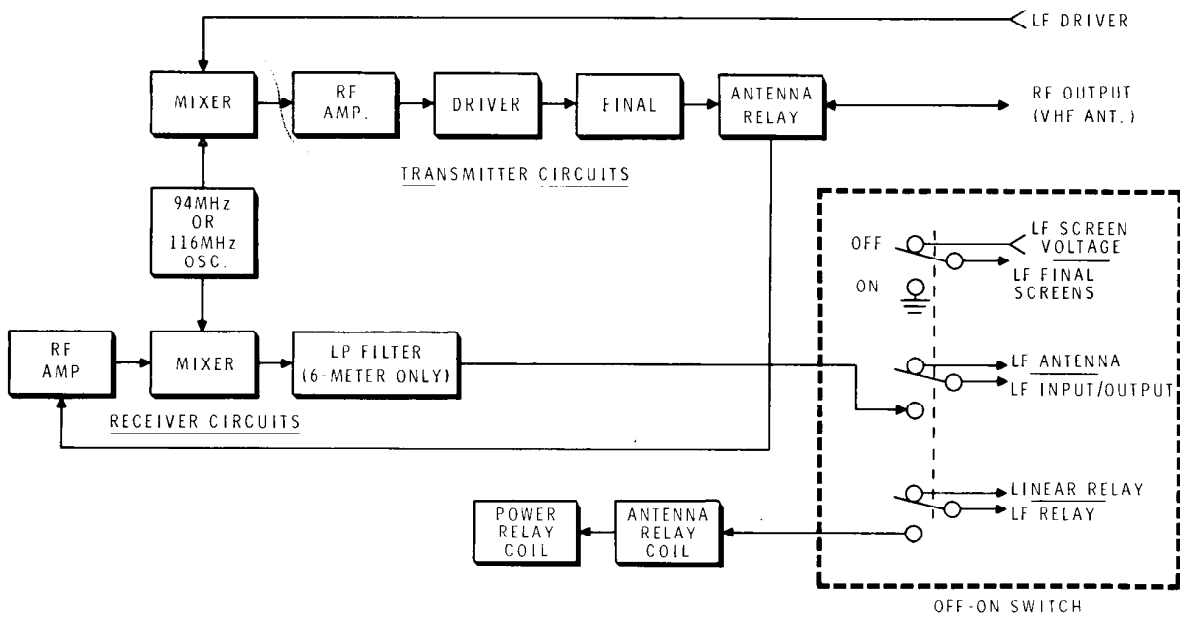

Figure 12-1
Block Diagram



HETERODYNE OSCILLATOR (Figure 12-2)

The heterodyne oscillator uses a fifth overtone, series-resonant crystal in a grounded grid circuit. Positive feedback is developed across capacitive voltage divider C1 - C2, and is fed back to the cathode of V4A through the crystal, X2.

RFC1 uses the capacity of the crystal to resonate at the oscillator frequency, thus inhibiting oscillations at spurious frequencies due to stray capacitance and lead inductances.

Test point #1 provides a convenient place to sample the oscillator output for alignment.

The output of tube V4A is coupled by C6 to the grid of tube V4B, which amplifies the oscillator signal. Its plate circuit is tuned by coil L9 and capacitor C3. The link of L9 feeds the oscillator signal to the cathode of mixer tube V2 for the receiver circuits. For the transmitter circuits, output from the plate of V4B is coupled through C12 to coil L10.

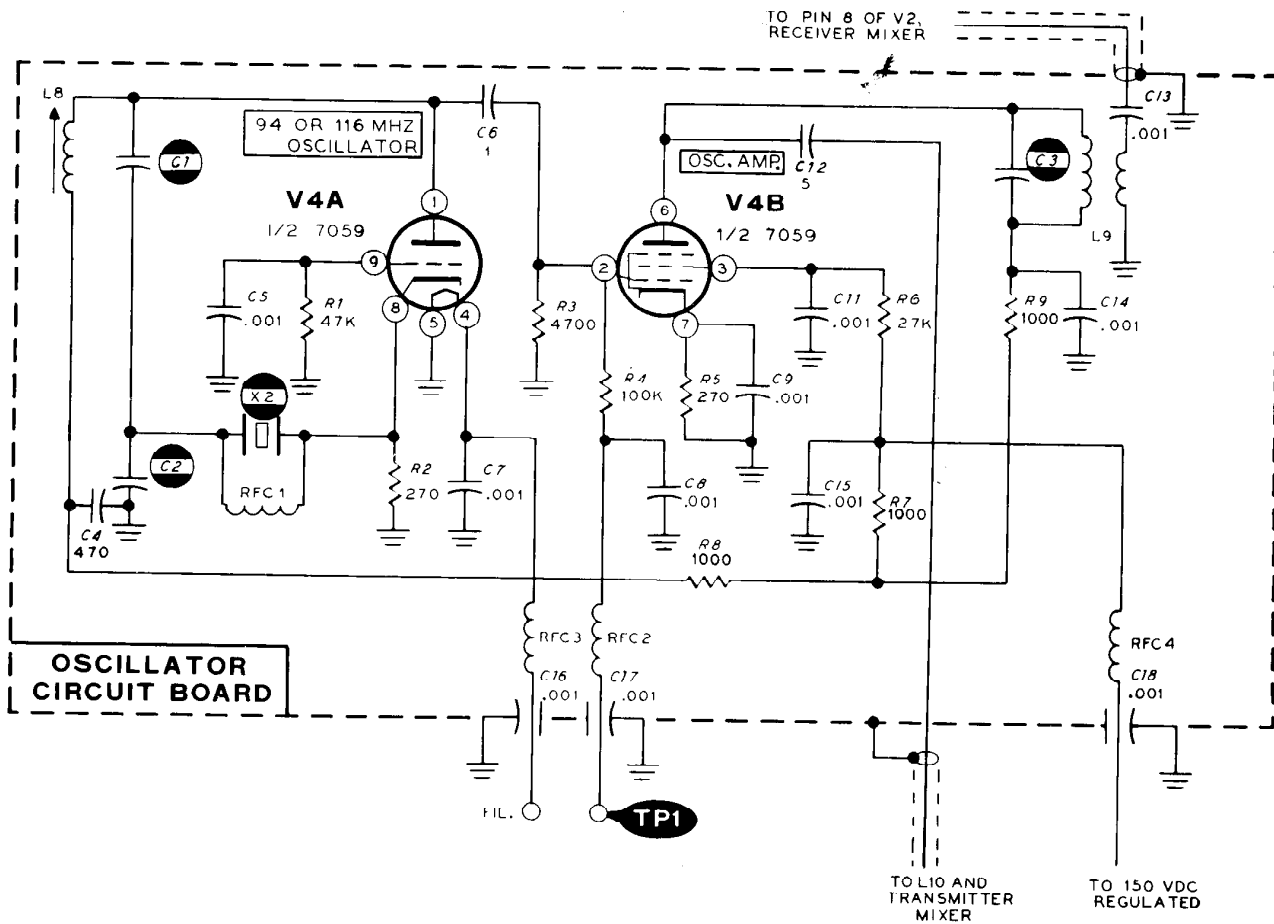

Figure 12-2

RECEIVER CIRCUITS

The incoming 2-meter signal is amplified and then heterodyned to the 50 MHz or 28 MHz input frequency of the low band equipment, which acts upon the input signal in the normal manner.

RF AMPLIFIER (Figure 12-3)

The incoming 2-meter signal is routed by the antenna relay to coil L1, which is paralleled by series capacitors C103 and C101A.

The tap on the coil provides impedance matching. C104 couples the signal to the grid of V1. The bandpass coupler formed by coils L3 (tuned by C107 and C101B) and L4 (tuned by C112 and C101C) transfers the signal through C113 to the grid of V2.

Coil L2 and series capacitor C105 form a network to feed back out-of-phase voltage to neutralize internally-coupled energy between the grid and plate of V1.

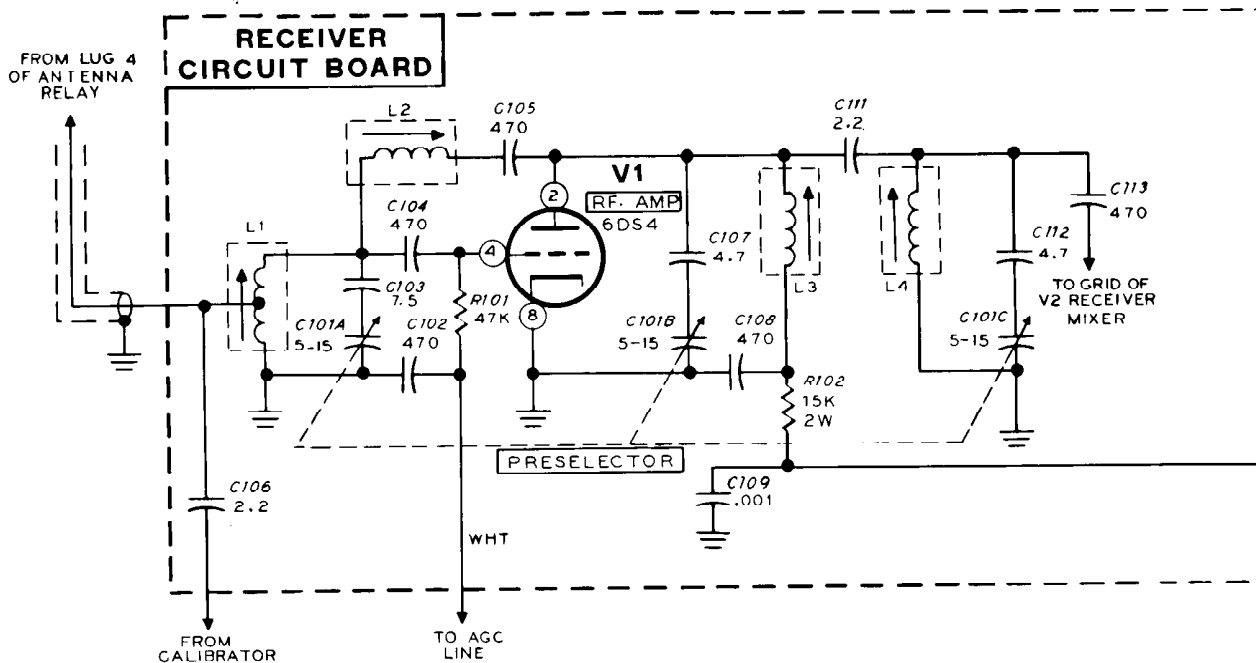

Figure 12-3

RECEIVER MIXER (Figure 12-4)

Amplified signal voltage at 144 MHz is fed to the grid of tube V2 through C113, and oscillator voltage at 94 MHz or 116 MHz is fed from C113 to the cathode. These signals combine to produce sum and difference frequencies in the plate circuit of V2. The difference frequency (144 MHz - 94 MHz = 50 MHz, or 144 MHz - 116 MHz = 28 MHz) is tuned by L5, C115 and C116.

When the output frequency is 50 MHz, the signal is coupled by C118 to a low-pass filter (composed of L6, L7, C119, C121 and C122). The output of the low-pass filter is fed to the Function switch, which routes the signal to the LOW f RECEIVER output socket.

When the output frequency is 28 MHz, the low-pass filter is not required and the signal is coupled by C118 directly to the Function switch, and from there to the LOW f RECEIVER output socket.

CRYSTAL CALIBRATOR (Figure 12-5)

When the Meter-Calibrate switch is placed in the CAL position, it supplies regulated positive voltages from voltage regulator tube V5 to the plate and screen of tube V3. This tube is connected in a Pierce oscillator circuit using a

1 MHz crystal. The tube also acts as an amplifier and produces 1 MHz harmonics which are used for calibration, and are coupled by C106 to the 144 MHz input of V1.

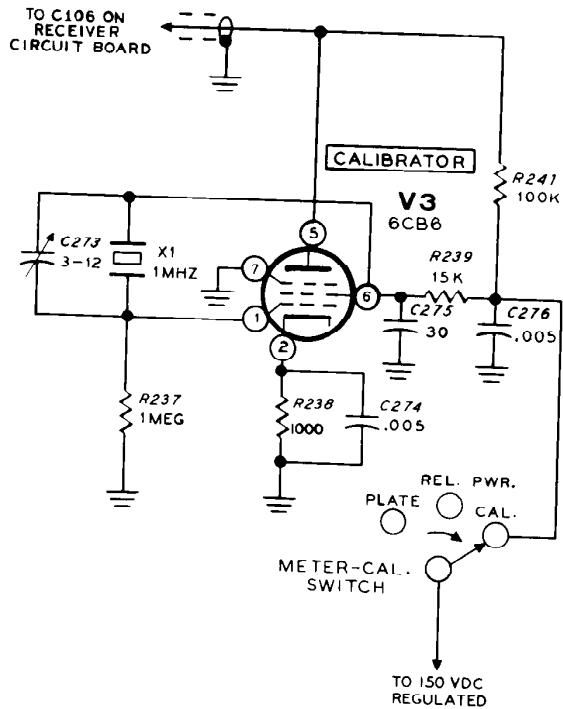

Figure 12-5

TRANSMITTER CIRCUITS

A driving voltage of either 50 MHz or 28 MHz is heterodyned to 144 MHz, amplified, and coupled to the output.

The drive line from the lower frequency equipment is not switched on and off, but remains permanently connected.

TRANSMITTER MIXER (Figure 12-6)

Driving voltage from the low band driver tube is coupled to the ~~cathode~~ ^{grid} of V6 by C221. The

~~terminating resistor, R209, is used only when the driving voltage is 50 MHz.~~

Voltage from the heterodyne oscillator is coupled by C12 through series circuit L10 - C219 to the ~~grid~~ ^{grid} of V6. The sum of the driving and oscillator voltage frequencies (28 MHz + 116 MHz = 144 MHz, or 50 MHz + 94 MHz = 144 MHz) is amplified by V6 and tuned by a band-pass network composed of L11, L12, C228, C227, C229, C225, C232, C226A, and C226B. This signal is coupled by C231 to the grid of tube V7.

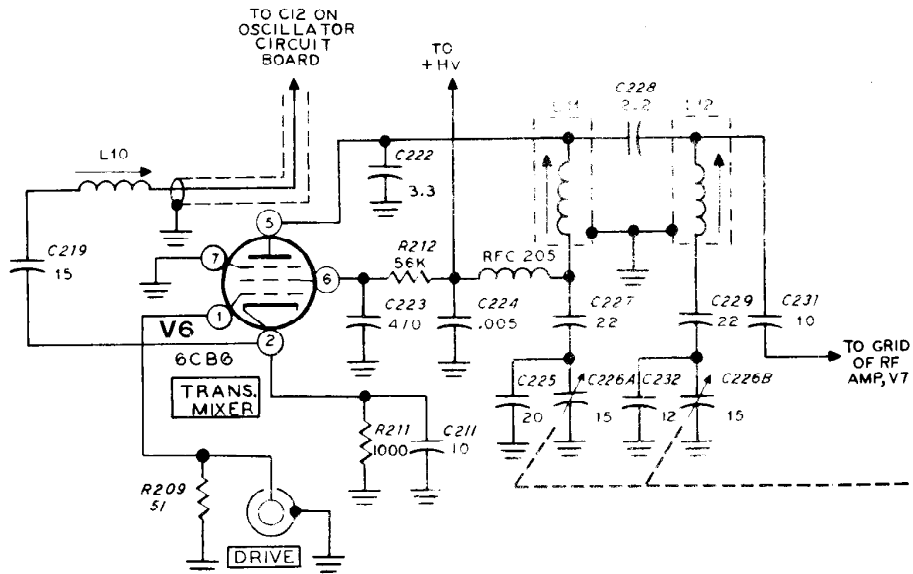

Figure 12-6

RF AMPLIFIER (Figure 12-7)

Tube V7 acts as a voltage amplifier. Its output is coupled by C235 to a pi network consisting of L13, C236, C226C, and C239, which serves to

match the output impedance of V7 to the grid of V8.

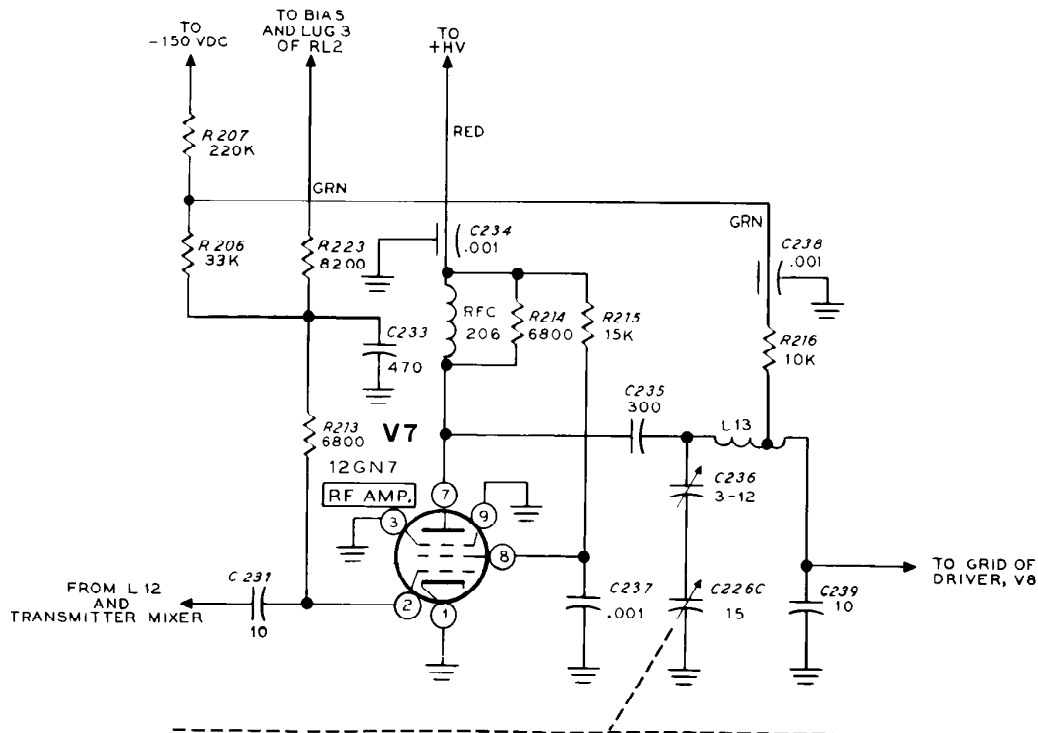

Figure 12-7

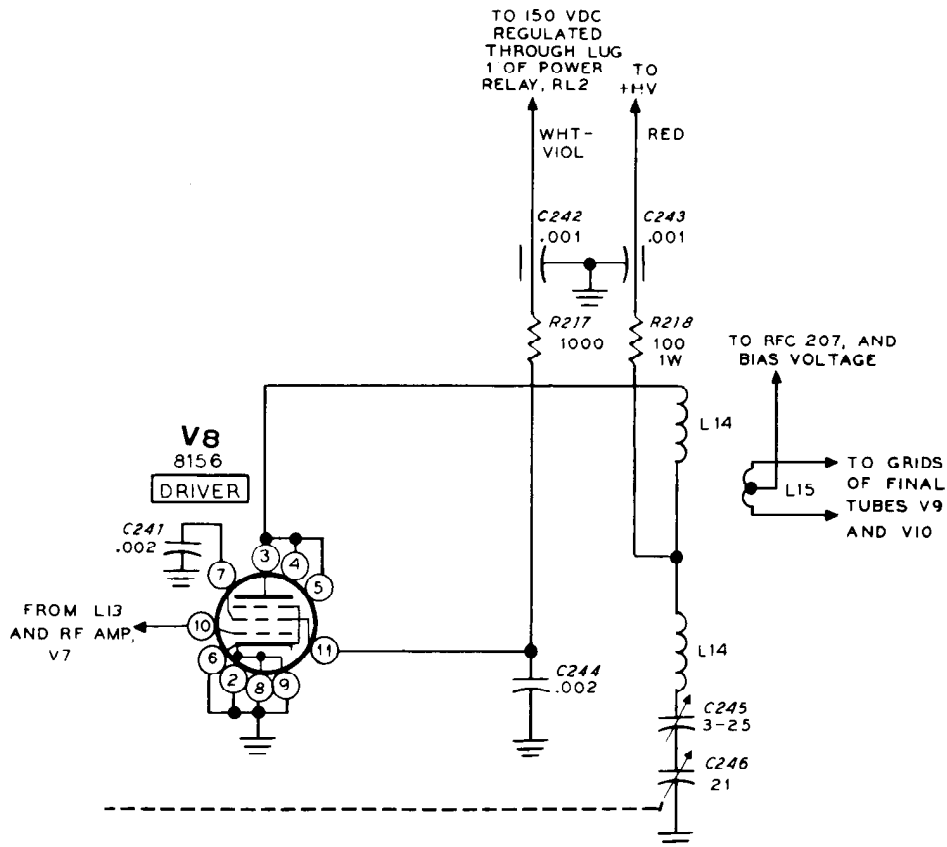

Figure 12-8

DRIVER (Figure 12-8)

Tube V8 amplifies its grid signal voltage to a level adequate to drive the final tubes. Its output is tuned by split tank coil L14 and series capacitors C245 and C246. Link coil L15 couples L14 to the grids of the final tubes.

FINAL AMPLIFIERS (Figure 12-9)

The final tubes are connected in a push-pull, class AB_1 , linear amplifier configuration. Fixed bias is adjusted by R225 and applied through R226 and RFC 207 to set the resting plate current to 50 mA.

The final tank coil, L16, is a hairpin loop tuned by butterfly variable capacitor C254.

Link coil L17 couples energy to the antenna through antenna relay RL1. This link is series-tuned by C258, which adjusts the loading.

The final tubes are neutralized by feeding back a portion of the output voltage to the tube grids through the capacitance of the neutralizing stubs, C255 and C256.

The three resistor-capacitor combinations connected from each of pins 1, 4, and 6 to ground, divide the cathode (plate) current of each tube among three leads, reduce the cathode lead inductance, and bypass any signal energy present in the cathode circuit which might cause instability.

Note that full plate voltage from the low band equipment is connected to the final tubes and tank circuit of the Transverter whenever the low band equipment is turned on, even when the Transverter is turned off.

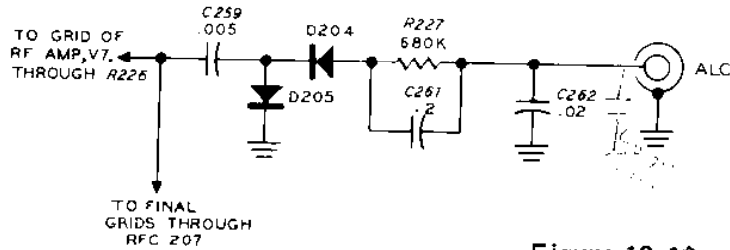

Figure 12-10

ALC CIRCUIT (Figure 12-10)

Voltage varying at an audio rate at the grids of the final tubes is coupled by C259 to a network composed of D204, D205, R227, C261 and C262 where it is rectified and filtered. This voltage is

then connected through the ALC connector to the driver as an aid in preventing overdriving and distorted signals.

METERING CIRCUITS (Figure 12-11)

The meter shows a full-scale reading when 1 mA of current is passing through it. The negative terminal of the meter is connected to chassis ground.

the Rel Pwr position, part of the RF output is coupled by C265 to D206, which rectifies the voltage and applies it to the meter. R229 acts as an adjustable voltage divider so that the meter may be adjusted to a full-scale reading with a given output.

Plate

When the Meter-Calibrate switch is placed in the Plate position, the cathode current of both final tubes is measured by the meter through multiplier resistor R221.

Calibrate

When the Meter-Calibrate switch is in the CAL position, the meter circuit is opened and the meter is out of the circuit.

Rel Pwr

When the Meter-Calibrate switch is placed in

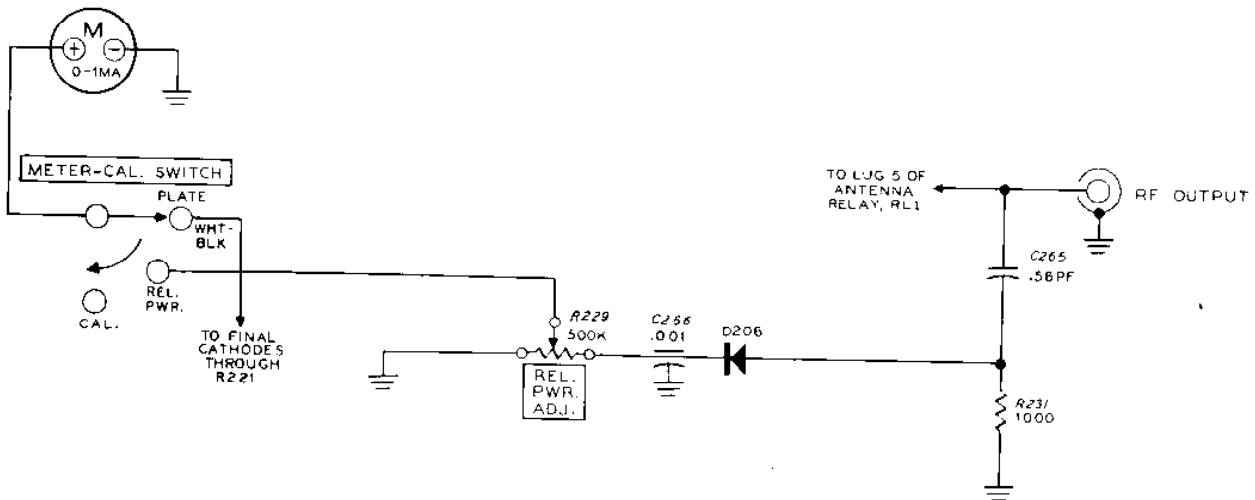

Figure 12-11

POWER SUPPLY (Figure 12-12)

The line cord is fused and bypassed, and contains RF chokes to keep RF out of the power line. The primary of the transformer is composed of two windings which are connected in parallel for 120 volt, 50/60 Hz, AC operation, or in series for 240 volt AC operation.

One secondary winding is connected in a full-wave voltage doubler circuit to produce +300 volts DC at 150 mA.

A half-wave rectifier and filter is also connected to this winding. It produces -150 volts DC for bias voltage.

A second winding produces 12.6 VAC used for filaments and the pilot light. Note that some tubes are connected in series and that bypassing and filtering is used.

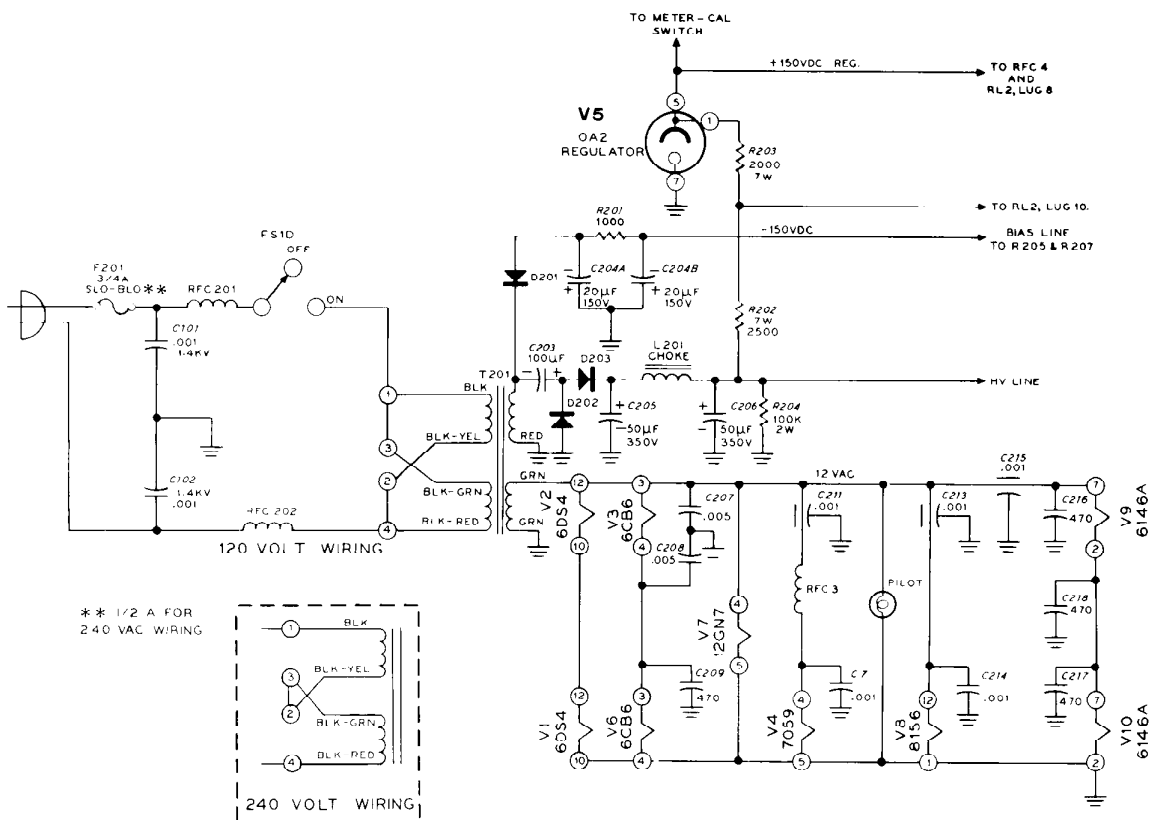

Figure 12-12

SWITCHING (Figure 12-13)

The Function switch (screened OFF-ON on the panel) performs the following functions:

The rear section, which has two terminals, turns the power line voltage off and on.

Section FS1C routes the output of the low band unit to its normal antenna or amplifier in the OFF position. When ON, this switch routes the output of the Transverter receiver to the antenna connector of the LB equipment for reception of 2-meter signals.

Section FS1B of this switch, in the OFF position, connects the screens of the final tubes in the LB equipment to their screen voltage source, thus placing them in operation. In the ON position, the DC circuit is opened and the screens are grounded so that the LB final tubes are inoperative.

Section FS1A of the switch permits the relay in the LB equipment to operate a linear amplifier change-over relay when it is in the OFF position. When the switch is ON, the LB equipment relay is switched to disconnect the amplifier relay (if any), and to connect the antenna and power relays in the Transverter so they will operate in unison with the LB equipment change-over relay.

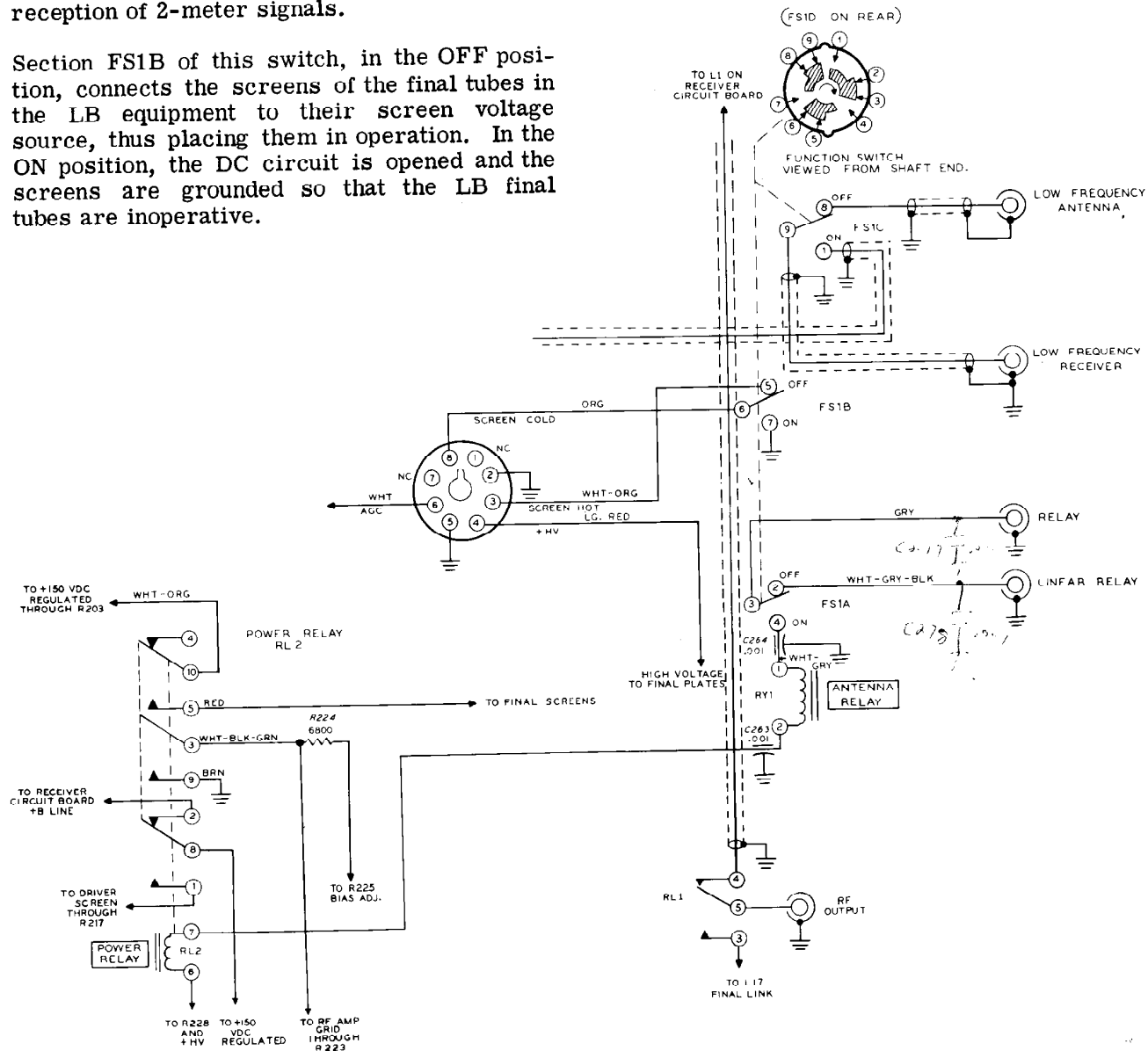

Figure 12-13

The antenna relay in the Transverter routes an incoming 2-meter signal to the receiver circuits, or connects the final tank circuit to the 2-meter antenna.

Contacts 10 and 5 of the power relay connect screen voltage to the final tubes (V9 and V10) in the closed (transmit) position. This circuit is open in the receive position, and the final tubes are inoperative. Contacts 3 and 9 of the

power relay provide a return circuit for the bias supply and place it into operation. This circuit does not operate when the contacts are in the open (receive) position.

Power relay contacts 8 and 2 connect regulated voltage to the receiver circuits in the open (receive) position. In the closed (transmit) position, contacts 8 and 1 connect this voltage to the screen of driver tube V8, placing it in operation.

NOTES:

1. RESISTOR VALUES UP TO 9999 ARE INDICATED IN OHMS.
RESISTOR VALUES OF 10 kΩ AND HIGHER ARE INDICATED IN kΩ OR MΩ.
ALL RESISTORS ARE 1/2 WATT UNLESS MARKED OTHERWISE.
2. CAPACITOR VALUES IN WHOLE NUMBERS ARE IN pF AND CAPACITORS IN DECIMALS ARE IN μF UNLESS MARKED OTHERWISE.
3. RELAY AND SWITCH CONTACTS ARE SHOWN IN THE OFF POSITION.
4. ALL COMPONENTS EXCEPT COILS AND TUBES ARE NUMBERED IN THE FOLLOWING GROUPS:

0-99	OSCILLATOR CIRCUIT BOARD PARTS
100-199	*RECEIVER CIRCUIT BOARD PARTS
200-UP	OTHER PARTS

*CAPACITORS CONNECTED TO THE BOTTOM OF THE RECEIVER CIRCUIT BOARD ARE NUMBERED IN THIS SERIES.
5. REFER TO THE X-RAY AND CHASSIS VIEWS FOR PHYSICAL LOCATION OF PARTS.
6. REFER TO THE IN CASE OF DIFFICULTY SECTION FOR VOLTAGE AND RESISTANCE CHARTS.

THE VALUE OF THESE PARTS WILL VARY, DEPENDING ON WHETHER YOU ARE USING A 6-METER OR A 10-METER IF SYSTEM. REFER TO THE FOLLOWING CHART. THESE PARTS ARE IDENTIFIED ON THE SCHEMATIC BY THE SYMBOL: 

ALTERNATIVE PARTS

PART	6-METER IF	10-METER IF
C1	5 pF	2.2 pF
C2	5 pF	7.5 pF
C3	10 pF	OMIT
C115	5 pF	56 pF
C116	56 pF	130 pF
R209	51 Ω	OMIT
X2	94 MHz	116 MHz

OSCILLATOR CIRCUIT BOARD RESISTANCE CHART VIEWED FROM PRINTED (UPPER) SIDE

FRONT OF CHASSIS ↑

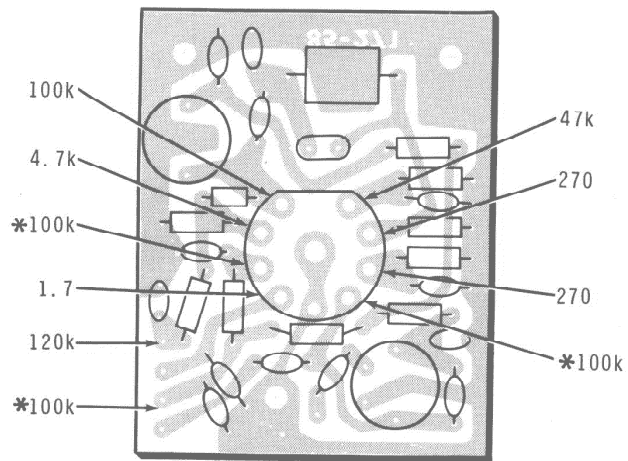

NOTES:

1. ALL RESISTANCES ARE IN OHMS (k=1000).
2. * = POWER SUPPLY CAPACITOR DISCHARGED.
3. METER SWITCH IN REL. PWR. POSITION.

Figure 11-4

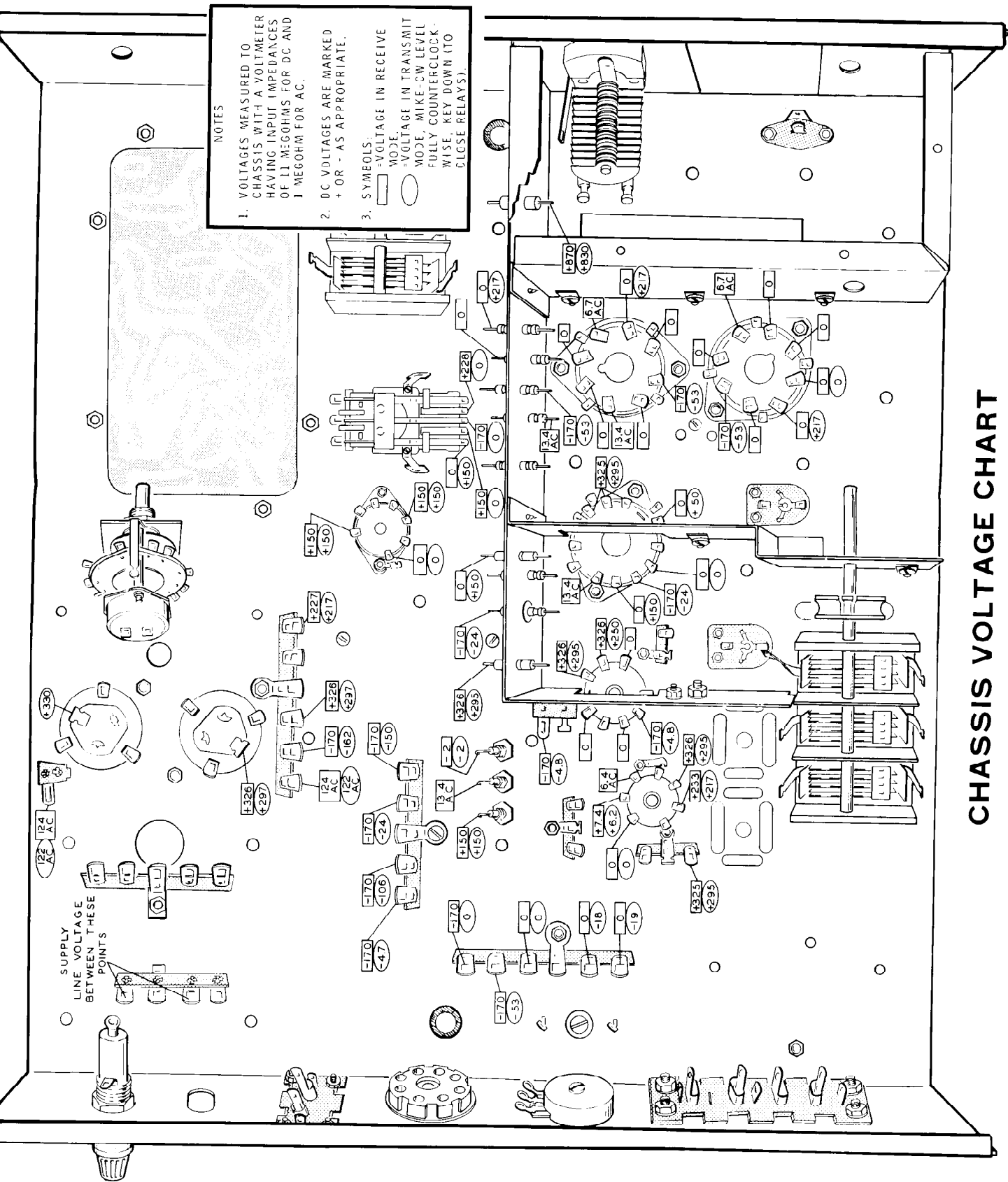

CHASSIS VOLTAGE CHART

FIGURE 11-5

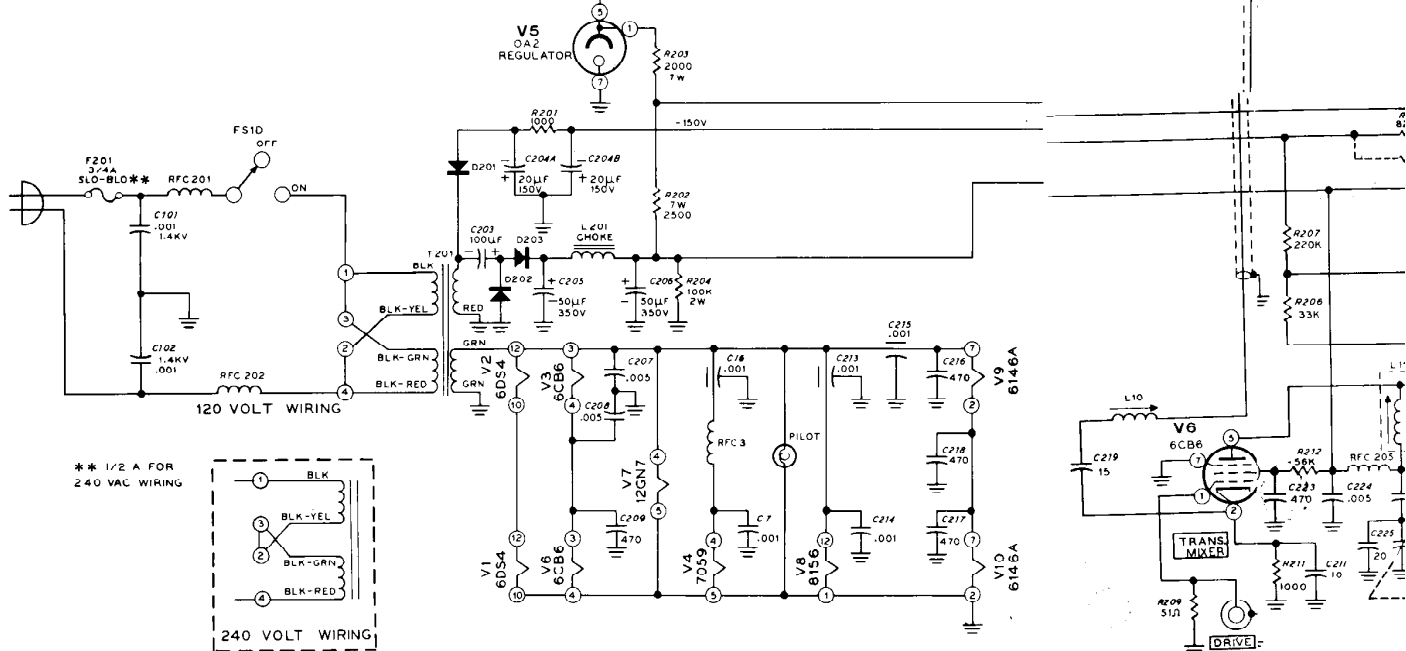
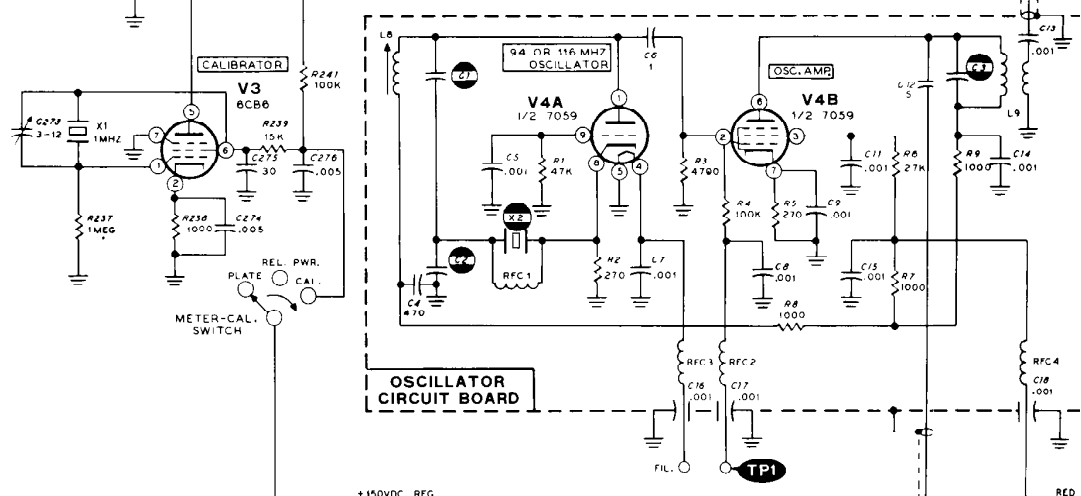
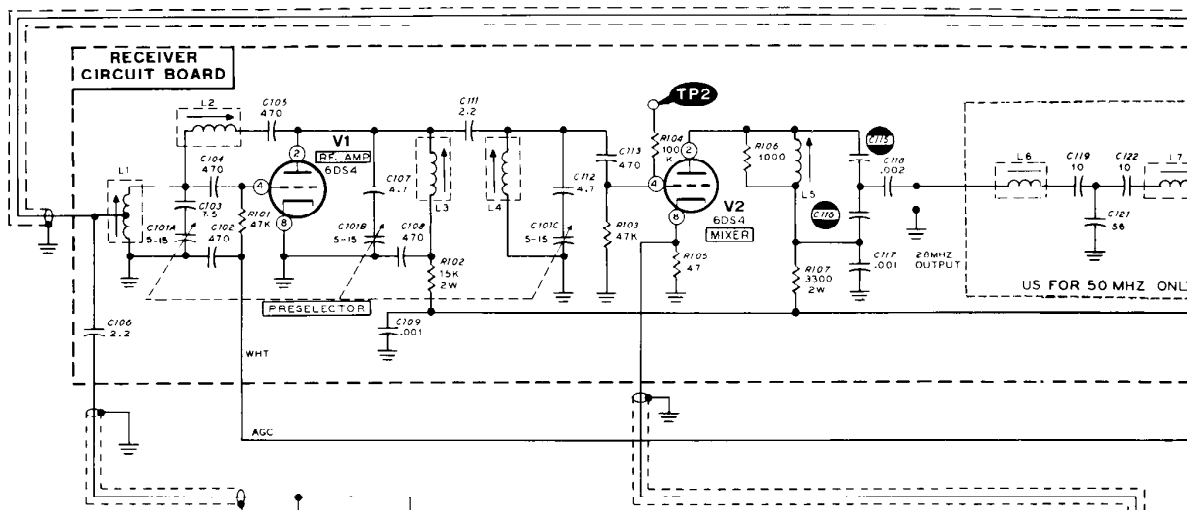

** 1/2 A FOR 240 VAC WIRING

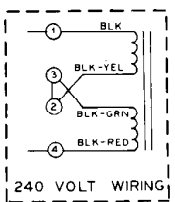

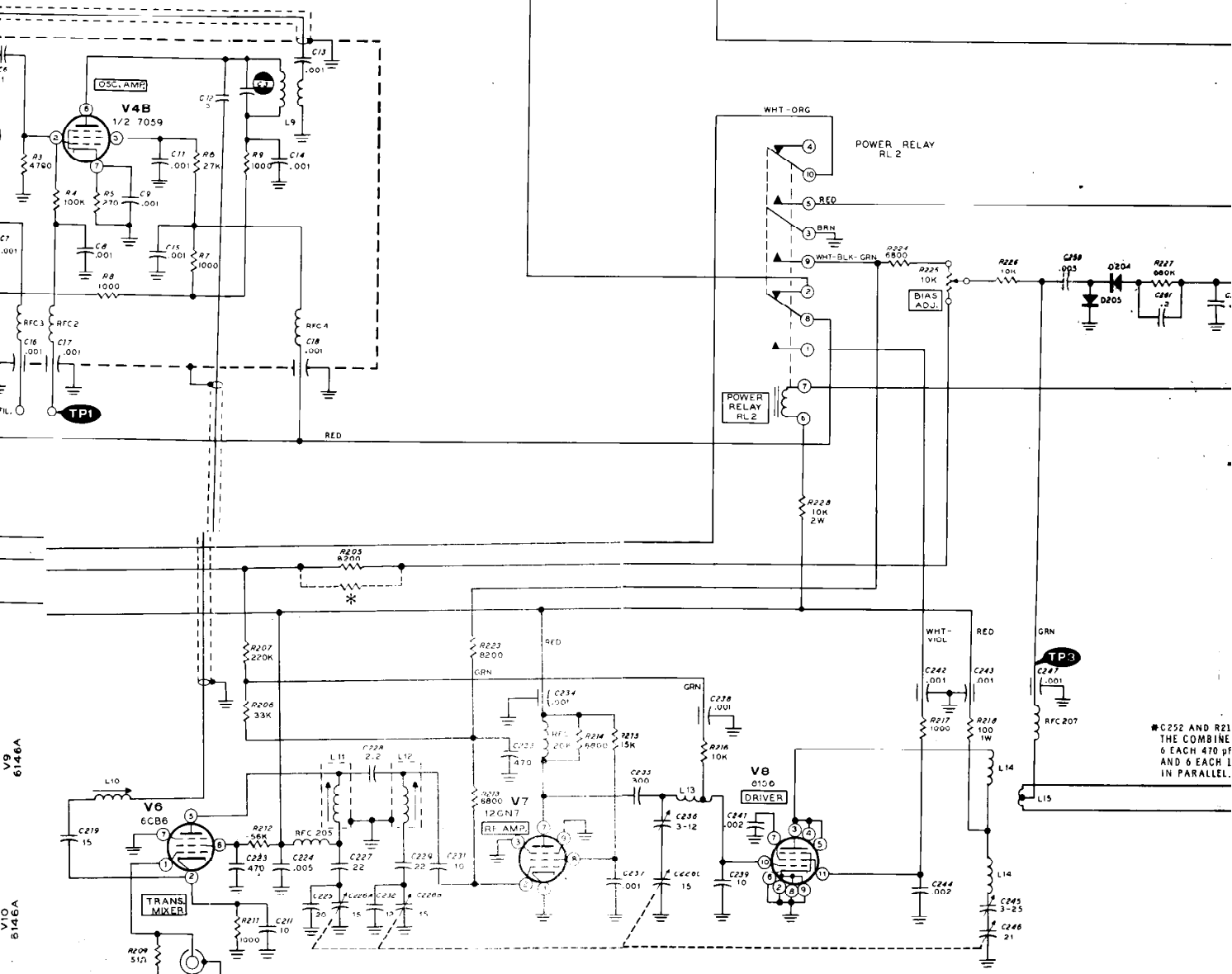
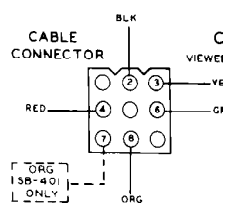
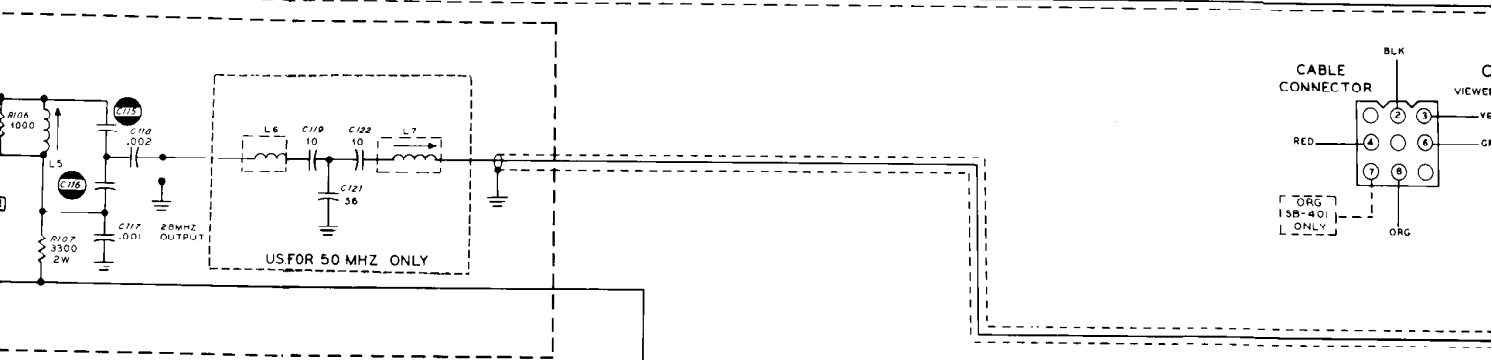

*47K OPTIONAL (SEE FIG. 4) USED TO REDUCE BIAS TO 100 VOLTS

V9 6146A
V10 6146A

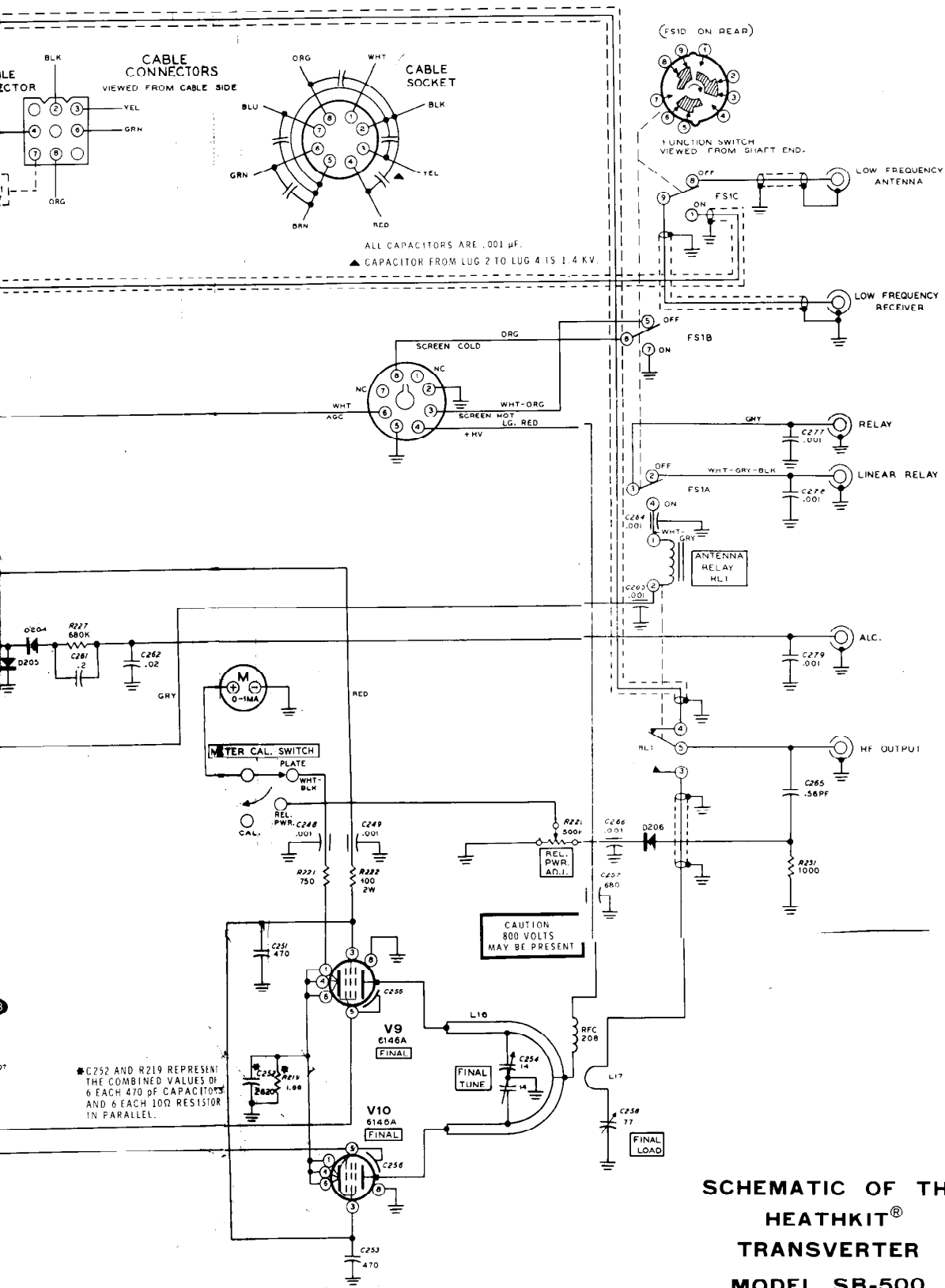

**SCHEMATIC OF THE
 HEATHKIT®
 TRANSVERTER
 MODEL SB-500**