

INTRODUCTION

The Heathkit Model SB-614 Station Monitor is a convenient instrument for use with an amateur radio station to continuously observe "on-the-air" signals. It can be used on all bands and frequencies from the 80-meter through the 6-meter amateur bands without additional tuning or modification. Ten watts of RF energy will provide a useful display, while a full 1000 watts of RF input can be adjusted for any display height with a front-panel-controlled attenuator.

The primary function of the Station Monitor is to display RF envelope (SSB), RF trapezoid (TRAP), or radioteletype (CROSS) transmitted signal patterns. It can also be used to monitor audio signals from other stations when used in conjunction with a receiver. The Monitor aids in proper alignment and tuning of a transmitter in AM, CW or SSB; its display will indicate nonlinearity, insufficient or excessive drive, poor carrier or sideband suppression, regeneration, parasitics, and CW key clicks. Approximately forty CRT display illustrations are shown and outlined in this Manual to illustrate transmitter problems.

For limited test applications, the Station Monitor can also be used as a normal oscilloscope. In this function, audio signals from 10 Hz to 50 kHz can be displayed with good sync capability and high input sensitivity. Also featured is a 10:1 vertical input switch attenuator which maintains a constant input impedance regardless of the switch position.

All-solid-state circuits are used, except for the display tube, and the push-pull CRT drivers improve the display focus and linearity. The RF input to the CRT deflection plates is also push-pull, and a one-piece, full CRT shield minimizes stray magnetic field effects. Automatic clamp circuitry is included for trapezoid displays. Display mode — SSB, Trap, or Cross — is shown by status lamps on the front panel.

The color and styling of the Station Monitor was designed to match that of the Heathkit line of amateur radio equipment. However, this unit can be used with similar amateur or commercial transmitters whose output levels and frequencies are within its specified limits. The Station Monitor can be wired to utilize either 110 to 130 VAC or 220 to 240 VAC, 50 or 60 Hz. With two circuit boards, a preassembled cable harness, and a wide-open layout, this Station Monitor is both an easy kit to assemble and a useful addition to your "ham shack."

Refer to the "Kit Builders Guide" for information about unpacking, parts identification, tools, wiring, soldering, and step-by-step assembly procedures.

OPERATION

In addition to the following material, you will also find much information on the use of oscilloscope monitors for amateur purposes in recent editions of the "Radio Amateurs Handbook," published by the American Radio Relay League.

RECEIVER MONITORING (Figure 4-1)

Connect a pair of wires or a cable to the receiver speaker terminals as shown. Then connect these wires or the cable to the VERT phono jack of the Monitor.

Place the RANGE switch at the 100 Hz position and the SWEEP control at approximately the center of its rotation. Adjust the VERTICAL GAIN and HORIZONTAL GAIN controls to produce the desired patterns as shown on Page 77 under "Transmit Envelope Patterns."

When the receiver is adjusted for normal operation on an average signal, the VERTICAL GAIN control should be adjusted to produce a pattern 1/2" to 1" high.

NOTE: If negative clipping of the display is observed, too much receiver audio signal is coupled into the Monitor. Reduce the receiver audio gain, or place Monitor Atten switch SW3 in the X10 position.

Many of the transmitter patterns described later may also be observed as a received signal. Bear in mind the limitations described in the following paragraphs, and refer to the appropriate sample patterns for the type of signal received. (See Figure 4-2, fold-out from this page.)

The receiver can produce several distinct effects which can alter or reshape the incoming signal into a display quite different from that which was transmitted. The two most pronounced effects are produced by the presence of AVC, and by the narrow bandwidth employed in newer receivers.

With the AVC on, as you observe a pulsing signal such as CW or sideband, the leading portion of the waveform may be displayed with considerable higher than normal amplitude. This leading portion will reduce in height as the AVC takes hold. You can see this effect most easily by observing the difference between patterns 35 and 36 on Page 83.

You may note the same distortion when watching voice patterns that produce momentary flat-topping on sideband. This problem can be avoided if you turn off the receiver AVC and reduce the RF gain sufficiently to prevent overload.

The bandwidth of the receiver IF determines the ability of the Monitor to reproduce a display of the actual transmitted signal. Refer to the pattern sequence shown in Figure 4-2. In order to obtain an undistorted display, the IF bandwidth must be roughly 10 times the modulating frequency. For example, a 3 kHz bandwidth will pass a 300 Hz square wave without distorting it, but a 1000 Hz square wave would be shown as a somewhat distorted sine wave. Therefore, SSB signals that are "flat-topping" may appear acceptable on the RF envelope patterns.

You can most easily identify flat-topped signals by observing the lack of peaks and valleys in the pattern. See Figure 4-2. It is possible, however, that the signal may be deliberately "shaped" by premodulation clipping and filtering in the transmitter to produce a pattern that may appear somewhat flat-topped.

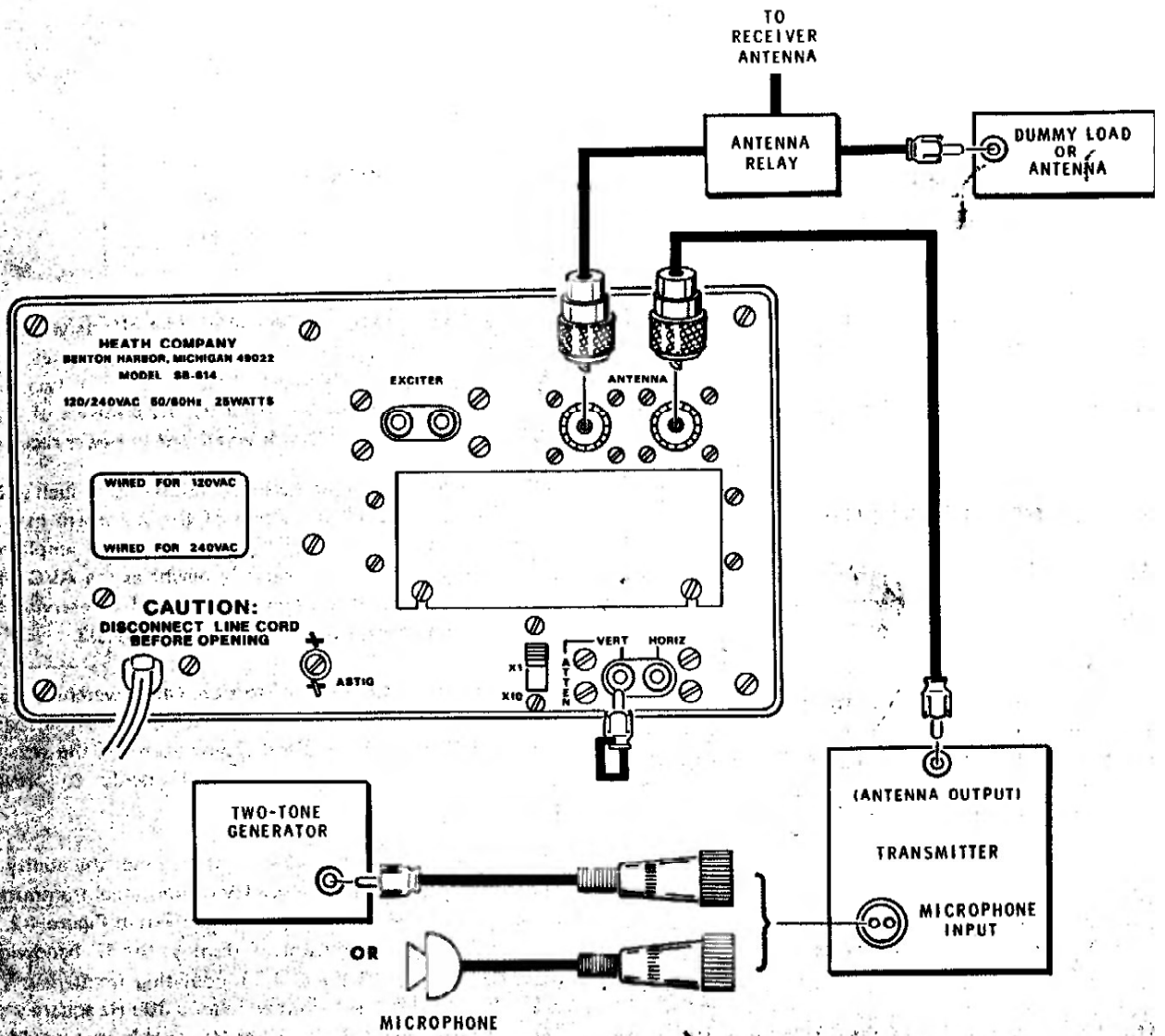

Figure 5-1

HEATHKIT

HEATHKIT

TRANSMITTER MONITORING (Figure 5-1)

Most transmitters have 50-75 Ω coaxial outputs. The following instructions are written for this type of connection with either a dummy load or an antenna. Make sure a dummy load or antenna is connected each time you operate the transmitter, either through the monitor as in the case of coaxial feed or directly where other antenna transmission line systems are used.

Refer to Figure 5-1 and connect the transmitter, the Station Monitor, and antenna or dummy load as follows:

NOTE: Avoid superimposed AC hum on the RF display by terminating the VERT input socket with the shorting plug, or by terminating the station receiver speaker. When you monitor audio signals from the receiver, the receiver audio must be muted during transmit intervals to avoid some superimposing of RF and audio signals.

Connect the RF output of the transmitter or linear amplifier to either ANTENNA jack on the rear of the Monitor.

Connect the dummy load or antenna to the other Monitor ANTENNA Jack.

3. Set the front panel controls as described in the "Adjustments" section of the Manual on page 61. Set the VERTICAL GAIN control fully counterclockwise.
4. Turn on the transmitter and adjust the VERTICAL GAIN, HORIZONTAL GAIN, and SWEEP controls for the desired pattern height and display.

IMPORTANT: Always keep the amplitude of the display within the graticule (screened lines) by adjusting the VERTICAL GAIN control. Failure to keep the display amplitude within the graticule viewing area can cause toroid coil L201 and resistor R201 to overheat, and may result in damage to either of these parts.

If the RF input to the Monitor approaches the 1000-watt limit, and if a steady CW or two-tone signal is being monitored, reduce the RF display to one-half the screen height and minimize the duration of the keyed signal. Normal keyed CW and SSB (voice modulated) signals may be displayed at full screen height for any period of time.

5. Check the modulation of an AM or SSB transmitter by connecting a two-tone generator to the microphone input of the transmitter. Check voice modulation by using a microphone to voice modulate the transmitter.
6. Refer to the "Transmit Envelope Patterns" on Page 77 to evaluate the transmitter display.

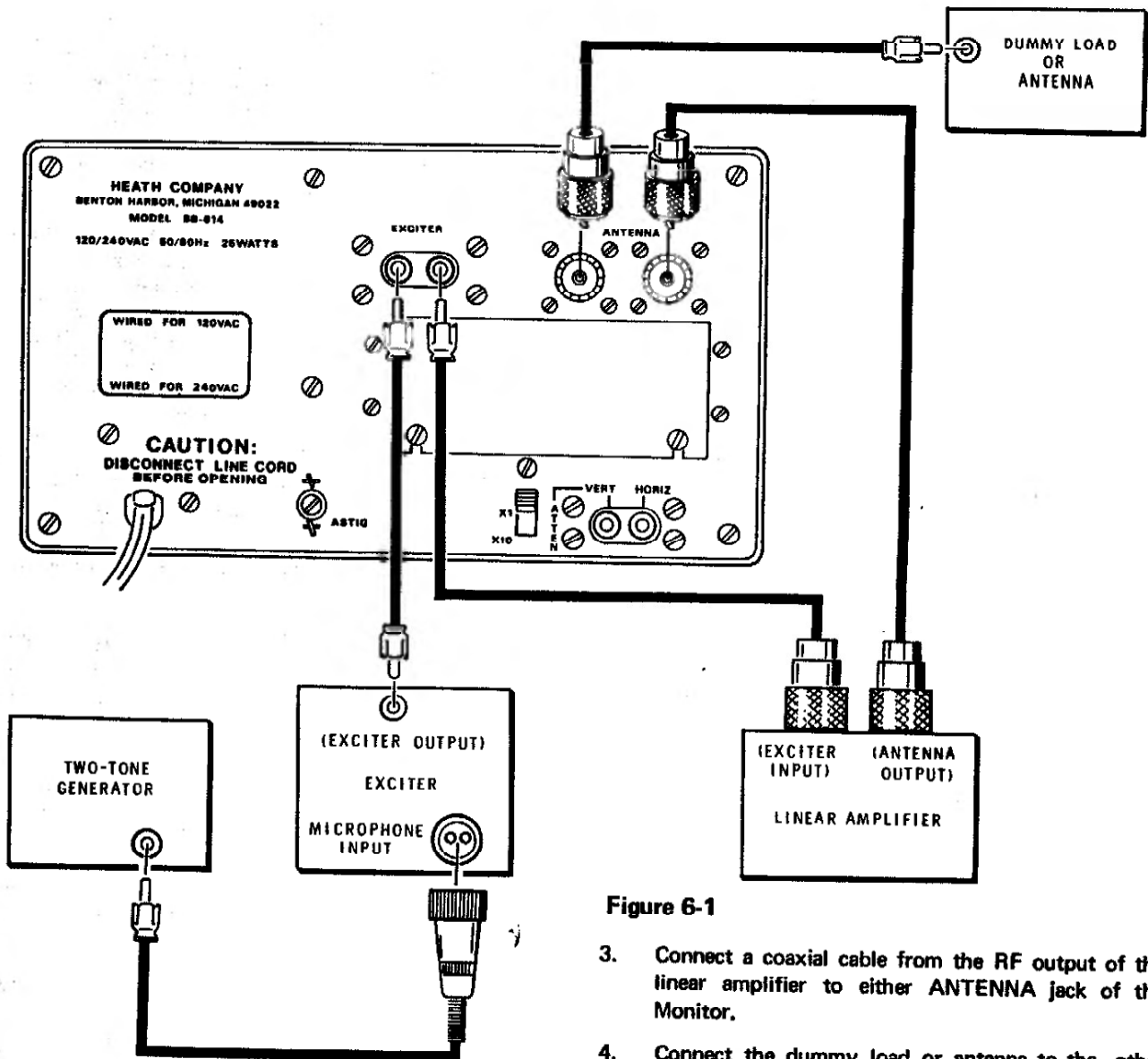
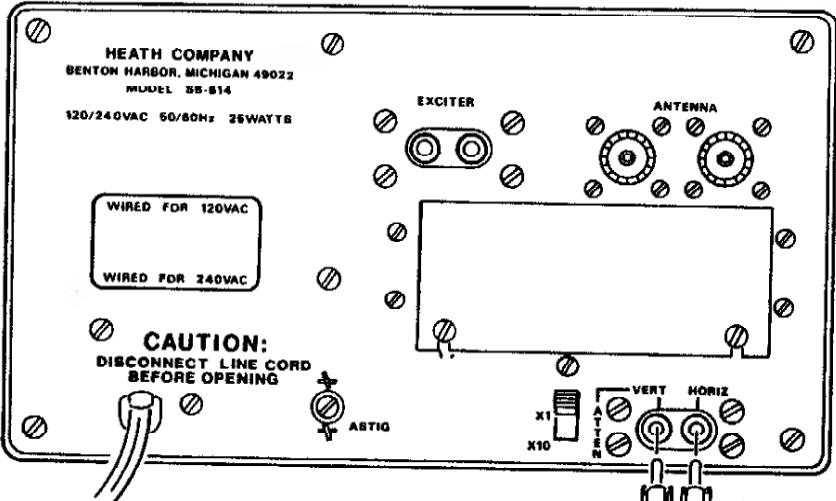

Figure 6-1

RF TRAPEZOID PATTERNS (Figure 6-1)

To check a linear amplifier for linearity, it is necessary to compare the exciter output with the RF output of the linear amplifier. The connections to be made for this purpose are shown in Figure 6-1.

1. Connect a coaxial cable from the RF output of the exciter to either EXCITER input jack of the Monitor.
2. Connect a coaxial cable from the other EXCITER jack on the Monitor to the input Jack of the linear amplifier.
3. Connect a coaxial cable from the RF output of the linear amplifier to either ANTENNA jack of the Monitor.
4. Connect the dummy load or antenna to the other ANTENNA jack on the Monitor.
5. Connect a two-tone generator to the microphone input of the exciter.
6. Set all front panel controls on the Monitor as directed in the "Adjustments" section of the Manual on Page 61, but with the MODE switch in the TRAP position.
7. Turn on the exciter and linear amplifier and adjust the Monitor VERTICAL GAIN and HORIZONTAL GAIN controls, and the transmitter audio gain control, for the desired display height pattern. If the RF input to the Monitor approaches the 1000-watt limit, and if a steady CW or two-tone signal is being monitored, reduce the RF display to 1/2 the screen height and minimize the duration of the keyed signal.



8. The trapezoid pattern that is shown on the Monitor screen is obtained by comparing the RF output signal from the exciter with the amplified RF output of the linear amplifier. Refer to the "Trapezoid Pattern" on pages 80 and 81 for display analysis.

NOTE: The RF trapezoid pattern only indicates the linearity of the linear amplifier. This setup should not be used for general monitoring as it does not evaluate the exciter signal.

RTTY CROSS PATTERNS (Figure 7-1)

1. Connect a coaxial or shielded cable from the "mark" channel of the RTTY terminal unit to the HORIZ input jack of the Monitor.
2. Connect a coaxial or shielded cable from the "space" channel of the RTTY terminal unit to the VERT input jack of the Monitor.
3. Set the front panel controls as directed in the "Adjustments" section of the Manual on Page 61.
4. Turn the terminal unit and Monitor on, and place the Monitor MODE switch in the CROSS position.

NOTE: The "mark" and "space" outputs of the terminal unit should be adjusted to provide equal output voltages from the two channels when properly tuned in. You can determine this by alternately inserting mark and space signals into the VERT input of the Monitor and adjusting the terminal unit's balance control for equal height from both channels.

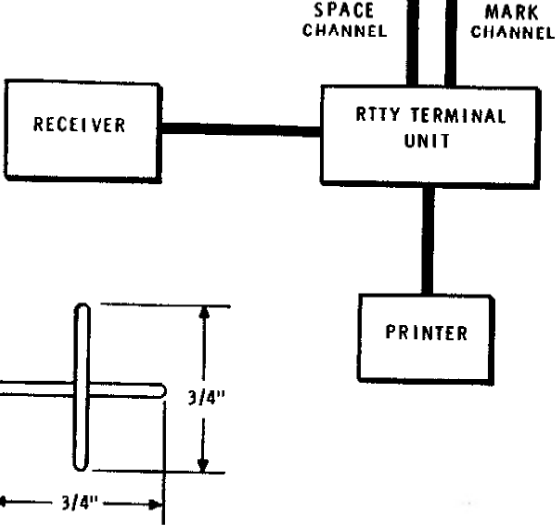

Figure 7-1

5. With the space channel connected to the VERT input and the mark channel connected to the HORIZ input, adjust the VERTICAL and HORIZONTAL GAIN controls on the Monitor to produce a cross pattern with equal height and width (about 3/4" x 3/4"). Once the desired size of the cross pattern has been set, the gain controls on the Monitor should not be changed, as this will interact with the true setting of the balance control on the terminal unit.
6. Refer to the "RTTY Cross Patterns" on Page 82.

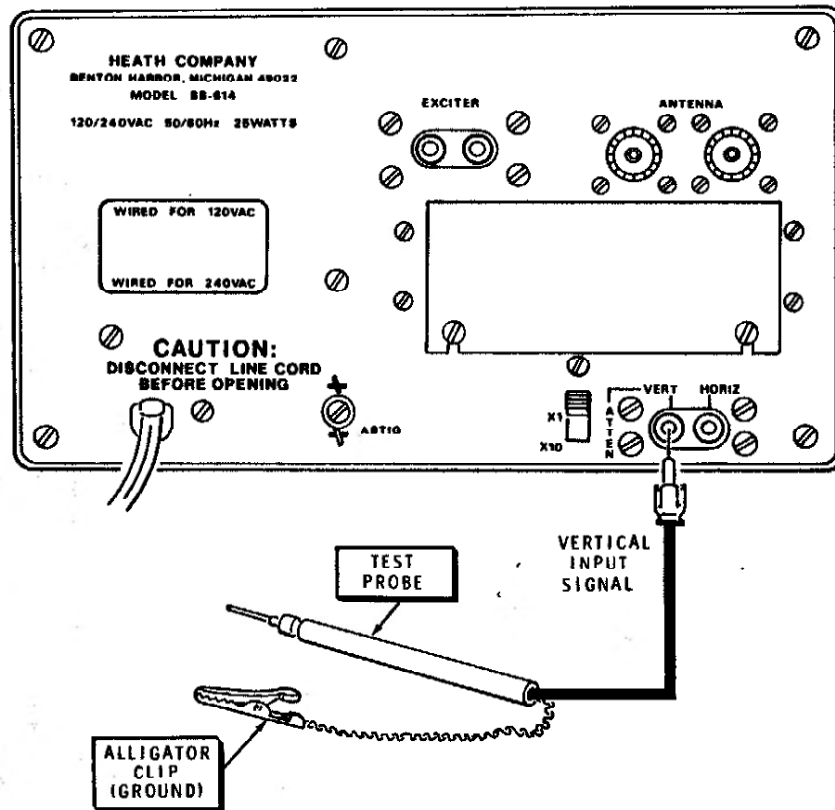

Figure 8-1

OSCILLOSCOPE USE (Figure 8-1)

The Station Monitor can be used as a normal oscilloscope for limited test applications where high sweep frequency or high vertical amplifier gain are not required.

For most applications, the MODE switch will be set at the SSB position to use the internal sawtooth generator for horizontal sweep. To use an external source for horizontal sweep, connect the horizontal signal to the HORIZ input, place the MODE switch at the CROSS position.

To use the Station Monitor as an oscilloscope, connect the leads and adjust the controls as follows.

1. Connect a test lead to the VERT input jack. Use a normal scope test probe.
2. Adjust the VERTICAL GAIN, HORIZONTAL GAIN, and SWEEP controls for the desired pattern.

NOTE: If negative clipping occurs, place the Atten switch in the X10 position.

TRANSMIT ENVELOPE PATTERNS

SSB signal, voice input, correctly adjusted.

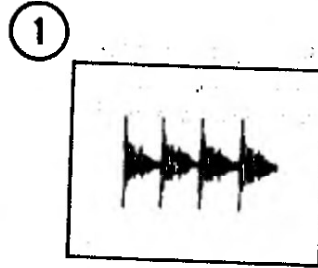

SSB signal, voice input, slightly excessive speech gain, or insufficient amplifier loading.

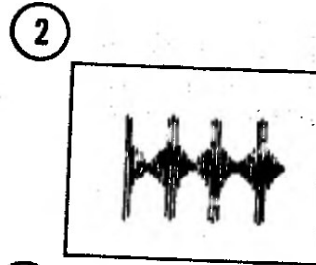

Pure CW carrier or perfect single tone input on SSB. May also occur on single tone SSB with excessive drive which results in amplifier "flat-topping." Note absence of fine ripple.

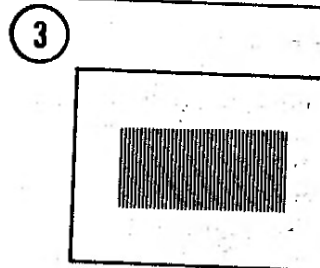

SSB signal, single tone input, sideband suppression down approximately 40 dB; or CW signal with spurious radiation down approximately 40 dB.

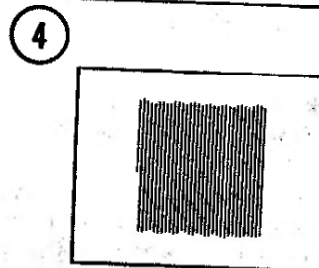

Same as 4 except down approximately 20 dB. In SSB, the poor suppression may be due to audio unbalance or improper RF phase shift. (Phasing system).

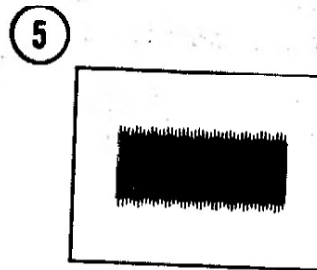

Same as 4, down approximately 10 dB.

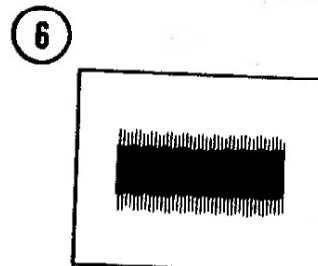

SSB signal, single tone input with carrier leakage. This pattern will have half the number of ripples due to poor sideband suppression (See waveform 5).

SSB signal, single tone input. Distortion in audio oscillator or audio system, balanced modulator detuned, or insufficient RF in balanced modulator.

SSB signal, single tone input. Very little sideband suppression. Caused by defective modulator stage, audio phase shift network, 90 degree RF phase shift component, partially shorted modulation transformer, secondary of transformer that feeds audio phase shift network shorted to ground, crystal oscillating on two adjacent frequencies simultaneously, or both heterodyne oscillators on together.

Normal double sideband, single tone input.

SSB signal, single tone input with no sideband suppression. May be due to one modulator stage dead, modulation transformer open or shorted, defective bandpass filter.

Normal SSB signal, 2-tone input, tones properly adjusted for equal amplitude.

SSB with carrier, single tone input. Incorrect value of carrier or modulation. Excessively rounded tops would indicate too much carrier.

7

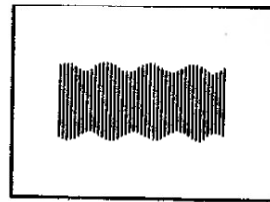

8

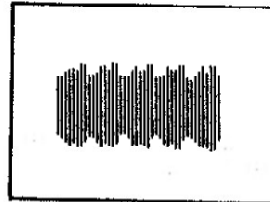

9

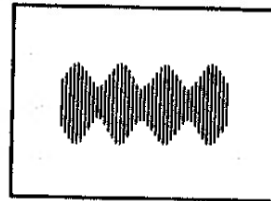

10

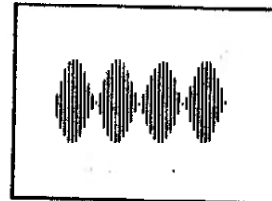

11

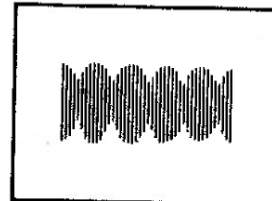

Plate modulated AM, or double sideband with carrier inserted, single tone input. Nearly 100% modulated. Excellent waveform.

Double sideband with carrier inserted (low level AM), single tone input. Too much carrier inserted. Note that the positive peaks flatten before a fine base line is obtained. Peak flattening may also be caused by insufficient antenna loading, insufficient interstage loading, an overdriven linear amplifier, poor dynamic power supply regulation, etc.

Double sideband with carrier inserted (low level AM), single tone input. Insufficient carrier insertion or excessive audio, resulting in high distortion (overmodulation). Also called Double Sideband Reduced Carrier (DSRC).

Low or high level AM with strong parasitics appearing on modulation peaks. Very fine, "grassy" appearance on peaks would indicate parasitics in the UHF range.

SSB, 2-tone input, or double sideband, single tone input. Carrier leakage in either causes uneven height of successive half cycles of modulation envelope.

Low or high level AM, single tone input. Severe distortion in modulator system, or AF tone generator, RF feedback to audio system, or RF feedback to previous low level stage.

12



approximately 100% modulation of carrier

13

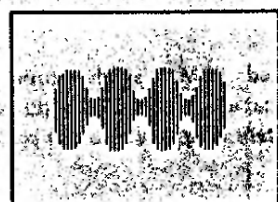

too much carrier inserted

14

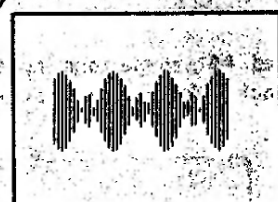

insufficient carrier insertion or excessive audio

15

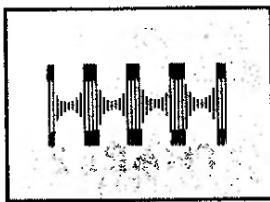

16

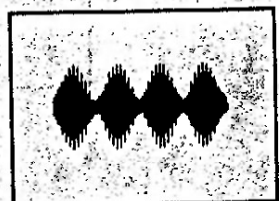

17

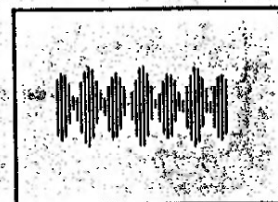

carrier leakage

18

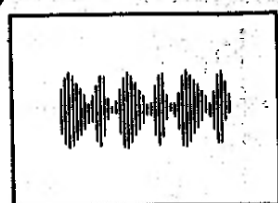

severe distortion

Nonlinearity in modulated RF stage, single tone input, due to insufficient excitation of a plate-modulated stage, overdrive to a grid-modulated stage, or insufficient antenna loading of a grid-modulated stage.

19

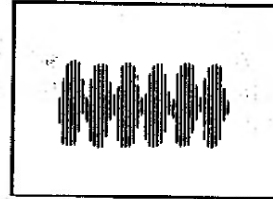

Plate-modulated AM, single tone input. Overdriven modulator incapable of 100% modulation. May also result from deliberately clipped audio not properly filtered.

20

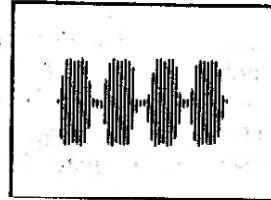
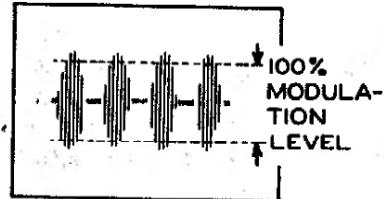

Plate-modulated AM, single tone input. Modulator output more than ample. Modulation in excess of 100% in both directions.

21



TRAPEZOID PATTERNS

RF trapezoid. Good linearity. Desirable pattern. 100% modulation.

22

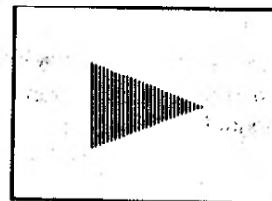

Modulation less than 100%. No distortion.

23

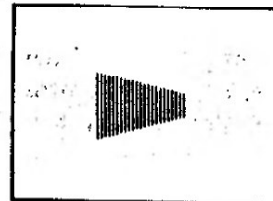

Nonlinear. Indicates overdrive, insufficient antenna loading, grid current curvature, or regeneration.

24



Nonlinear. In linear operation this also indicates regeneration or excessive grid bias.

25

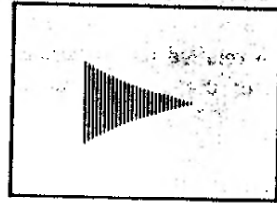

Parasitics occurring on modulation peaks.

26

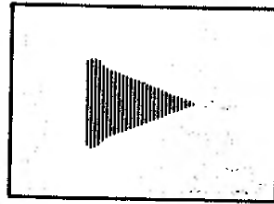

Grid modulation with improper neutralization and reactive load.

27

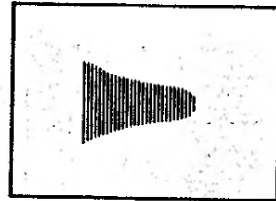

Unmodulated carrier. Can be caused by:

- No signal at horizontal deflection plates.
- Tone test oscillator inoperative.
- Gain control turned off on transmitter or oscilloscope.
- Audio failure in transmitter.

28

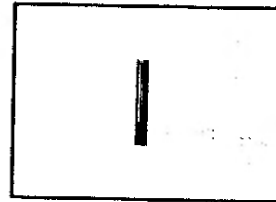

RTTY CROSS PATTERNS

Mark only. The relative narrowness of the ellipse provides good indication of the channel separation capability in the terminal unit.

Space only. The relative narrowness of the ellipse provides good indication of the channel separation capability in the terminal unit.

RTTY signal, proper shift, correctly tuned in.

Incorrect shift, space tuned in, or selective fading.

Incorrect shift, mark tuned in, or selective fading.

"Straddle" tuning of incorrect shift.

29

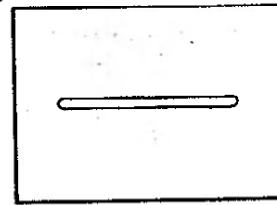

30

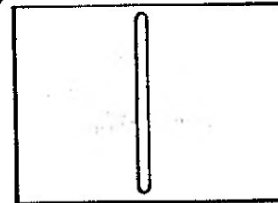

31

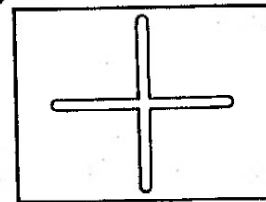

32

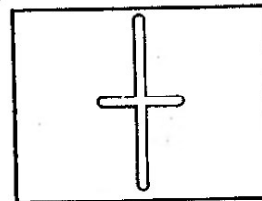

33

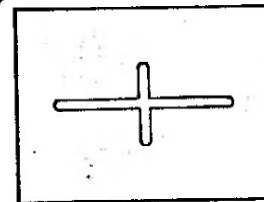

34

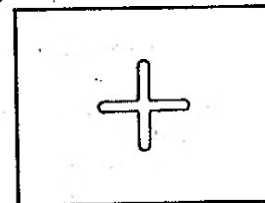

CW PATTERNS

Good CW pattern, properly shaped keying, string of dots. Pattern can be synchronized using automatic keyer or bug.

35

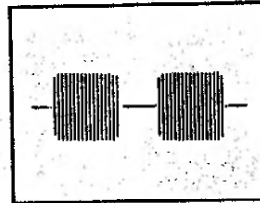

CW pattern showing effect of receiver AVC action or poor power supply regulation in the transmitter.

36

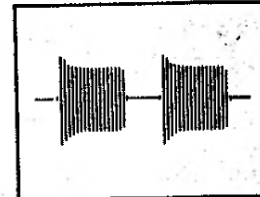

CW pattern, mild key clicks.

37

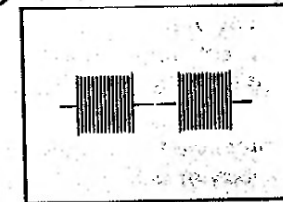

CW pattern, severe key clicks.

38

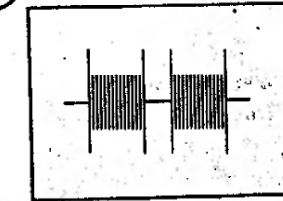

CW pattern with considerable backwave, RTTY transmitter pattern with unequal mark and space outputs, or RTTY receiver pattern with signal not properly centered in IF bandpass, or bandpass too narrow.

39



CW pattern, string of dots indicating poor contacts or contact bounce in keying mechanism.

40

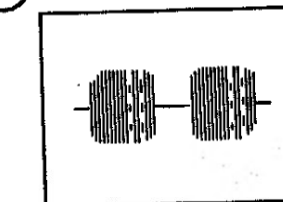

RECEIVER PATTERNS

SIGNAL AT XMTR

RECEIVER BANDWIDTH

3KC

6KC

16KC

LOAD
IA



1000 — tone
no flat topping.



1000 —
severe flat topping

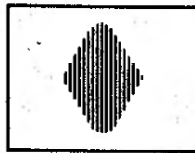

300 —
no flat topping

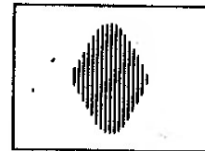

300 —
severe flat topping

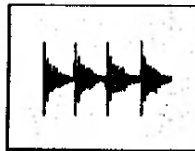

SSB speech
(typical voice)
no flat topping

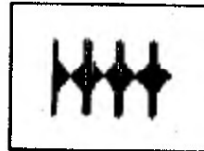

Note reduction of
sharp peaks on 3KC
bandwidth



severe flat topping



Note Valley does not go into base line.

Figure 4-2

FINDING THE AREA OF TROUBLE

If a voltmeter is available, check the voltage readings against those shown on the Schematic diagram. NOTE: All voltage readings were taken with a high impedance input voltmeter. Voltages may vary as much as 20%. Also study the "Circuit Description" and "Block Diagram" so you will be better able to analyze and locate the trouble.

Because most of the circuits are DC coupled, it is almost impossible to list troubles in a "cause and effect" type of chart. For example, a saturated transistor on one side of a differential amplifier may appear as a trouble on the other side. However, a "Troubleshooting Chart" is provided to help you isolate the problem to a particular area of the Monitor.

Since the Position controls are at the front of the differential amplifiers and affect each succeeding stage, they serve as troubleshooting aids. When you are troubleshooting the vertical amplifier, for instance, first check the associated power supply voltages. Then check transistors Q104 and Q106. These voltages should vary as the Vertical Position control is turned. If these voltages change accordingly, the trouble may be in the CRT circuit. If the voltages do not change, the problem is either Q104 or Q106 or the preceding stages. Move the voltmeter to the preceding stage (Q103 and Q105) and repeat the procedure until you locate the trouble.

NOTE: In an extreme case where you are unable to resolve a difficulty, refer to the "Customer Service" information inside the rear cover of the Manual. Your Warranty is located inside the front cover.

Troubleshooting Chart

	CONDITION	POSSIBLE CAUSE
A.	Resistance from lug 1 of CRT to ground less than 3 M Ω .	<ol style="list-style-type: none"> 1. Diodes D105 or D106. 2. Capacitors C121 or C123. 3. Power transformer. 4. Focus or Intensity controls incorrectly wired. 5. Resistors R14 or R16.
B.	Resistance from junction of R148, R149, R151, and R152 to ground less than 100 k Ω .	<ol style="list-style-type: none"> 1. Diodes D104, D111, D112, or D113. 2. Zener diodes ZD101 or ZD102. 3. Transistors Q104, Q106, Q114, Q118, or Q121. 4. Capacitors C124 or C128. 5. Capacitors C19, C21, C201, or C202.
C.	Resistance from emitter (E) of Q122 to ground less than 150 Ω .	<ol style="list-style-type: none"> 1. Transistors Q102, Q109, Q112, Q113, or Q116. 2. Capacitor C15.
D.	Resistance from collector (C) of Q122 to ground less than 450 Ω .	<ol style="list-style-type: none"> 1. Diodes D107 or D108. 2. Zener diode ZD103. 3. Transistor Q122. 4. Capacitors C126 or C127.

CONDITION	POSSIBLE CAUSE
E. Indicator lamps and CRT filament do not light.	<ol style="list-style-type: none"> 1. Fuse. 2. Incorrectly wired fuseholder or transformer primary leads. 3. On-Off switch on Intensity control.
F. Indicator lamps do not light, but a spot or trace is seen on CRT.	<ol style="list-style-type: none"> 1. Resistor R13. 2. Indicator lamp terminal strip incorrectly wired. 3. Mode switch incorrectly wired.
G. CRT filament and indicator lamps light, but no trace or spot on CRT screen.	<ol style="list-style-type: none"> 1. No -1400 volt supply. 2. Incorrectly wired CRT socket. 3. Capacitors C107, C108, C112, or C114. 4. Incorrectly wired Position controls. 5. Transistors Q102, Q103, Q105, Q116, Q117, or Q119. 6. Mode switch.
H. Unable to center spot or trace on CRT screen.	<ol style="list-style-type: none"> 1. Mode switch in wrong position. 2. Check items G3 through G6, above. 3. RFC1, RFC2, RFC3, or RFC4. 4. Capacitors C19, C21, C201, or C202.
I. No horizontal trace deflection (Mode switch in SSB position.)	<ol style="list-style-type: none"> 1. Mode switch incorrectly wired or defective. 2. Red, brown, or black shielded cables to Mode switch shorted or open. 3. Range switch incorrectly wired. 4. Sweep control incorrectly wired. 5. Transistors Q109, Q111, Q112, Q113, or Q115. 6. Diodes D103 or D104. 7. Capacitor C108. 8. No +9.0 or +180-volt power.
J. No horizontal trace deflection (Mode switch in Cross position.)	<ol style="list-style-type: none"> 1. No signal at Horiz input jack. 2. White shielded cable open or shorted. 3. Horiz input jack incorrectly wired.

	CONDITION	POSSIBLE CAUSE
K.	No vertical deflection (Mode switch in SSB position).	<ol style="list-style-type: none"> 1. No signal at Vert input jack. 2. Low input level, Atten switch in X10 position. 3. Vert input or Atten switch incorrectly wired. 4. Blue shielded cable at Atten switch open or shorted. 5. Yellow shielded cable at Vertical Gain control shorted. 6. Diodes D101 or D102. 7. Transistors Q101 through Q106. 8. Vertical Gain control. 9. Check items H3, H4, and I8, above.
L.	Poor focus of trace or spot on CRT screen.	<ol style="list-style-type: none"> 1. Paper backing not removed from graticule. 2. Astig control incorrectly wired. 3. CRT socket incorrectly wired. 4. Focus control incorrectly wired. 5. Resistors R14, R16, or R154. 6. Low -1400 volts from power supply. 7. CRT.
M.	Trace will not disappear when Intensity control is turned CCW.	<ol style="list-style-type: none"> 1. Transistor Q114. 2. Capacitor C111. 3. Resistors R125, R126, or R153.
N.	Audio signal waveforms distorted.	<ol style="list-style-type: none"> 1. Distorted audio input signal. 2. Input signal too strong, Atten switch in X1 position. 3. Check items K3, K6, K7, K8, and K9, above.
P.	Poor synchronization.	<ol style="list-style-type: none"> 1. Diode D201. 2. Orange shielded cable. 3. Transistors Q107 through Q111.
Q.	RF waveforms distorted.	<ol style="list-style-type: none"> 1. Distorted input signal. 2. Diode D201. 3. Coil L201. 4. Capacitors C201 or C202. 5. Redress leads around CRT (See Pictorials 9-2 and 9-3 on Page 52.) 6. RF input frequency too high (above 54 MHz).

	CONDITION	POSSIBLE CAUSE
R.	Unable to obtain trapezoid pattern on CRT (Mode switch in Trap position. No spot, no trace).	<ol style="list-style-type: none"> 1. Diodes D202 or D203. 2. Transistor Q201. 3. Zener diode ZD201. 4. Capacitors C205 or C206.
S.	Spot will not clamp to right side of screen (Trap position).	<ol style="list-style-type: none"> 1. Gray shielded cable open. 2. Transistors Q101 or Q201. 3. Readjust Horizontal Pos control. 4. Mode switch incorrectly wired (brown wire).
T.	Trapezoid pattern distorted or is only vertical trace.	<ol style="list-style-type: none"> 1. Exciter and linear amplifier incorrectly connected to Monitor (see Figure 6-1 on Page 74). 2. Diode D204. 3. Violet shielded cable. 4. Capacitors C207 or C208. 5. Resistor R207. 6. Recheck Q1 through Q6, above.
U.	RF vertical display not high enough, or too high, for input level. Display behaves erratically when Vertical Gain control is turned.	<ol style="list-style-type: none"> 1. Atten switch and associated capacitors incorrectly wired or installed. (See Detail 10-1B and Pictorial 10-2 on Page 55.)
V.	SSB indicator lamp stays on regardless of switch setting.	<ol style="list-style-type: none"> 1. Diode D1.
W.	Low -1400-volt supply.	<ol style="list-style-type: none"> 1. Check items A1 through A5.
X.	+180-volt supply too high or too low.	<ol style="list-style-type: none"> 1. Check items B1 through B5.
Y.	+9.0-volt supply too high or too low.	<ol style="list-style-type: none"> 1. Check items C1 and C2. 2. Check items D1 through D4.

SPECIFICATIONS

RF SAMPLING SECTION

Frequency Coverage	80 through 6 meters (3.5 - 54 MHz).
Sensitivity	1/4" vertical deflection at 10 watts. 3/4" vertical deflection at 100 watts.
RF Power Limits	
Exciter Input (50-75 Ω)	10 to 300 watts.
Antenna Input (50-75 Ω)	10 to 1000 watts.
Insertion Loss	Negligible.

VERTICAL AMPLIFIER

Input Impedance	1 M Ω shunted by 75 pF.
Sensitivity	60 millivolts/1/4" vertical deflection.
Attenuator	2-position: X1: 1 volt rms maximum. X2: 10 volts rms maximum.
Frequency Response	10 Hz to 50 kHz typical.

HORIZONTAL AMPLIFIER

Input Impedance	1 M Ω .
Sensitivity	60 millivolts rms/1/4" horizontal deflection.
Frequency Response	10 Hz to 3 MHz typical.



SWEEP GENERATOR

Type Recurrent, automatic sync.

Frequency Range 10 Hz to 10 kHz in three ranges.

GENERAL

CRT 3RP1/A; flat face; green, medium-persistence phosphor.

Graticule 1/4-inch squares; 6 x 8 (1.5" x 2" viewing area).

Power supplies Solid-state rectifiers, regulated amplifier supplies.

Power Requirements 110-130 or 220-260 VAC, 50/60 Hz, 35 watts.

Front Panel Controls Intensity - Off/On.
 Mode - SSB, Trap, Cross.
 Focus.
 Vertical Gain.
 Vertical Position.
 Horizontal Gain.
 Horizontal Position.
 Sweep - variable.
 Range - 100 Hz, 1 kHz, 10 kHz.

Rear Panel Controls Astigmatism.
 Vertical Attenuator - X1, X10.

Rear Panel Connectors Antenna - 2 coaxial.
 Exciter - 2 phono.
 Vertical Input - 1 phono.
 Horizontal Input - 1 phono.

Dimensions (overall) 7-1/4" high x 10-1/4" wide x 15-1/4" deep
 (18.4 cm x 26 cm x 38.7 cm).

Net Weight 12 lbs. (4.48 kg).

The Heath Company reserves the right to discontinue products and to change specifications at any time without incurring any obligation to incorporate new features in products previously sold.

VERTICAL INPUT

EXCITATION

ANTENNA

CIRCUIT DESCRIPTION

Refer to the Schematic diagram (fold-out from Page 103) and the Block Diagram (fold-out from Page 92) while reading this Circuit Description.

To help you locate specific parts in the Station Monitor or on the Schematic, the resistors, capacitors, transistors, and diodes are numbered in the following groups.

- 1-99 Parts mounted on the chassis.
- 100-199 Parts mounted on the main circuit board.
- 200-299 Parts mounted on the demodulator circuit board.

VERTICAL AMPLIFIER

A signal applied to the Vert input jack is coupled through the frequency-compensated attenuator network. Capacitor C12 blocks any DC from the attenuator circuits. From the attenuator circuit, a portion of the input signal is coupled through resistor R107 and capacitor C101 to the gate of transistor Q101. Resistor R107 protects Q101 from being damaged in case a high potential is applied to the input jack while vertical Atten switch SW3 is in the X1 position. Diodes D101 and D102 are transistors connected to provide a zener action. These diodes limit the input signal to approximately ± 9 volts, which further protect Q101 from excess gate voltage. Capacitor C101 improves high frequency response by forming a high frequency path around R107.

Transistor Q101 is a field effect transistor (FET) connected as a source follower. This type of transistor provides the high impedance input necessary to prevent loading of the signal source.

The signal is AC-coupled through capacitor C107 and applied across Vertical Gain control R9. A portion of this signal is directly applied to the gate of source follower Q102. Since the following stages are DC coupled, capacitor C107 DC-isolates Q101 from Q102. This prevents any trace shift due to varying signal levels.

The output from source follower transistor Q102 is amplified by transistor Q103. A portion of the signal applied to the base of Q103 appears at its emitter. Because transistors Q103 and Q105 have a common emitter resistance, the signal present at the Q103 emitter is effectively coupled to the emitter of Q105.

Transistor Q105 functions as a common base amplifier whose base is held constant by Vertical Pos control R7. This control positions the trace by applying a DC voltage to the base of transistor Q105, causing a DC unbalance in the vertical amplifier. When the collector output voltage of Q103 decreases, its emitter voltage will increase. An increased emitter voltage at Q105 reduces its forward bias and increases its collector output voltage. The signal at the collector of transistor Q105 reduces its forward bias and increases its collector output voltage. The signal at the collector of transistor Q105 is 180 degrees out of phase with the signal at the collector of Q103, forming a "push-pull" type of amplifier required to drive the CRT deflection plates. Capacitor C113 is an emitter bypass capacitor to boost the gain at high frequencies. Emitter resistors R131 and R132, with Vert Bal control R128, establish the DC gain of the vertical amplifier.

Output amplifiers Q104 and Q106 again amplify the differential signal and drive the vertical plates of the CRT.

SWEEP GENERATOR

Capacitor C203 couples a portion of the vertical input audio signal to the base of transistor Q107 through resistor R202 and diode D201, a shaping network. Diode D201 also demodulates any AM or SSB RF signal applied to the RF sampling circuit.

The preshaped sync signal is applied to a Schmitt trigger circuit, Q107 and Q108, a regenerative bistable circuit which produces a rectangular pulse output each time it is triggered and reset.

Transistors Q111 and Q112 form an astable multivibrator. When transistor Q112 is conducting and Q111 is cut off, one or more of the timing capacitors (C15 through C17) are charged through transistor Q112. As the voltage at the emitter of Q112 approaches the voltage at the base, as a result of charging the capacitor, Q112 will cut off and drive Q111 into conduction. The charged timing capacitor will now discharge through the constant current source circuit of Q113. The setting of Sweep control R12 determines the current flowing through Q113, which, in turn, determines the discharge current (and discharge time) of the timing capacitor. As the timing capacitor discharges, a positive-going ramp voltage (sawtooth) is generated and coupled to the horizontal amplifier. The frequency of the horizontal sweep is determined by the particular timing capacitor selected by Range switch SW4 and the discharge current.

Since transistors Q109 and Q111 have a common emitter resistor (R117), a signal applied to the base of Q109 is emitter coupled to transistor Q111. Thus, the pulse output (sync signal) of the Schmitt trigger, Q108, is coupled to Q111. This causes Q111 to turn on and Q112 to cut off and start the sweep just prior to the time it would normally begin.

When the signal at the emitter of Q109 goes positive, a positive pulse is coupled through capacitor C111 to the base of blanking amplifier Q114.

A negative-going output pulse is coupled through capacitor C119 to the grid of the CRT. This pulse turns off the electron beam during retrace, preventing the retrace from appearing on the CRT.

RF SAMPLING CIRCUIT

Transmitted RF signals as high as 1000 watts (PEP) may be viewed on the Station Monitor when these signals are properly terminated in a 50 or 75 ohm transmission line or dummy load. The transmitting antenna feedline is coupled through the Antenna jacks on the rear panel of the Monitor. A portion of the RF signal is sampled from the feedline and coupled through capacitor C1 to RF attenuator switch SW1, which can be reduced in 11 step intervals. Capacitors C2 through C11 are connected in series in descending value on the switch. Attenuator switch SW1 has no stepping detent, and is mechanically coupled to Vertical Gain control R9.

From the RF attenuator switch, the RF signal is coupled to toroid coil L201, a bifilar-wound coil on a toroid core. It is connected as an unbalanced-to-balanced balun. The balanced output of coil L201 couples the RF signal through DC blocking capacitors C201 and C202 to the vertical deflection plates of the CRT. Resistor R201 broadens the frequency response of the balun.

RF chokes RFC1 through RFC4 offer high impedance to the RF signals on the vertical deflection lines to prevent the RF sample signals from affecting the vertical deflection amplifier circuits of Q104 and Q106.

HORIZONTAL DEFLECTION

Mode switch SW2 has three positions which determine the type of signal that will be used for horizontal deflection in the CRT. When the Mode switch is in the SSB position, the sawtooth signal from the sweep generator is coupled from the collector of transistor Q113 to the gate of transistor Q115. The operation of the horizontal amplifier is identical to that of the vertical amplifier. The positive-going sawtooth voltage is amplified and applied to the horizontal deflection plates of the CRT. This increasing voltage causes the electron beam to sweep across the face of the CRT, producing a visible trace.

When Mode switch SW2 is in the Trap position, a signal from the Exciter input Jack is rectified by RF demodulator diode D204. This rectified RF voltage is coupled through capacitor C208 to the gate of transistor Q115. When a modulated RF signal is applied directly to the vertical deflection plates of the CRT and the modulating audio signal is applied to the horizontal deflection plates, a trapezoidal pattern is presented on the screen of the CRT. Resistors R2 and R206 form an RF voltage divider network so the voltage limitation of diode D204 is not exceeded. RF filtering is accomplished through resistor R207 and capacitor C207.

In the Cross mode of operation, any appropriate signal applied to the Horiz input jack is coupled through capacitor C18 and the contacts of Mode switch SW2 to the gate of transistor Q115.

CLAMPER CIRCUIT

In the Trap mode of operation, when no RF signal is present at the Monitor input jacks, the trace is reduced to a small spot. Since the small spot could burn a hole in the CRT phosphor coating, a clamp voltage is generated to prevent this. A supply voltage, coupled to transistor Q201, causes Q201 to conduct. Resistor R112, in the base bias network to transistor Q119, also becomes the drain load for transistor Q201, causing it to conduct. Since Q201 is in parallel with the Horizontal Pos control, the base bias on Q119 is reduced. This unbalances the horizontal amplifier transistors, thus moving the spot off the right side of the CRT screen.

When an RF signal is applied to the Antenna jacks, a small portion of the signal is coupled through capacitor C204 from voltage divider network R1 and R203 to the negative voltage doubler circuit consisting of diodes D202 and D203 to produce a negative bias. This negative DC voltage is applied to the gate of Q201, causing the transistor to stop conducting which, in turn, causes the drain voltage and the base bias of Q119 to return to normal. This causes the trace to return to the center of the CRT screen.

Capacitor C205 and resistor R204 form the filter network. Capacitor C206 is a timing capacitor which holds a slight charge to keep transistor Q201 cut off. This causes a slight time delay to momentarily hold the spot on the screen. Thus, the display remains visible and is kept from jumping to the edge of the display area during normal voice modulation. The gate of the transistor is protected by the zener action of diode ZD201.

With the Mode switch in the Trap position, the gate of transistor Q102 is shorted to chassis ground. Shorting this gate avoids any "blooming" of the spot when the spot is clamped to the right of the display area.

POWER SUPPLY

Line voltage is connected through the slow-blow fuse and On-Off switch SW5 (on the Intensity control) to the primary windings of the power transformer. The dual-primary windings may be connected in parallel for 120-volt operation or in series for 240-volt operation.

A high voltage secondary winding of the power transformer is connected to the voltage doubler circuit consisting of diodes D105 and D106 and capacitors C122 and C123. Capacitor C121 filters this negative high voltage which is fed through resistor R154 to the grid of the CRT. The Intensity and focusing voltages are also supplied to the CRT from the voltage divider network consisting of resistors R14 through R17. A separate 6.3-volt winding supplies the CRT filament voltage.

A low voltage secondary winding is connected to the voltage doubler circuit consisting of diodes D107 and D108 and capacitors C129 and C131. Zener diode ZD103 and resistor R157 maintain a constant voltage to the base of pass transistor Q122. The output voltage is regulated at +9.0 volts DC by series pass transistor Q122 and zener diode ZD103. Capacitors C126 and C127 filter the rectified voltage and capacitor C125 prevents the pass transistor from oscillating in case of load loss.

Another secondary winding is connected to a full-wave bridge rectifier consisting of diodes D109 through D113. Capacitors C128 and C124 filter the rectified voltage. Zener diodes ZD101 and ZD102, and resistors R155 and R156, provide a regulated +180 volts DC output.

CHASSIS PHOTOGRAPHS

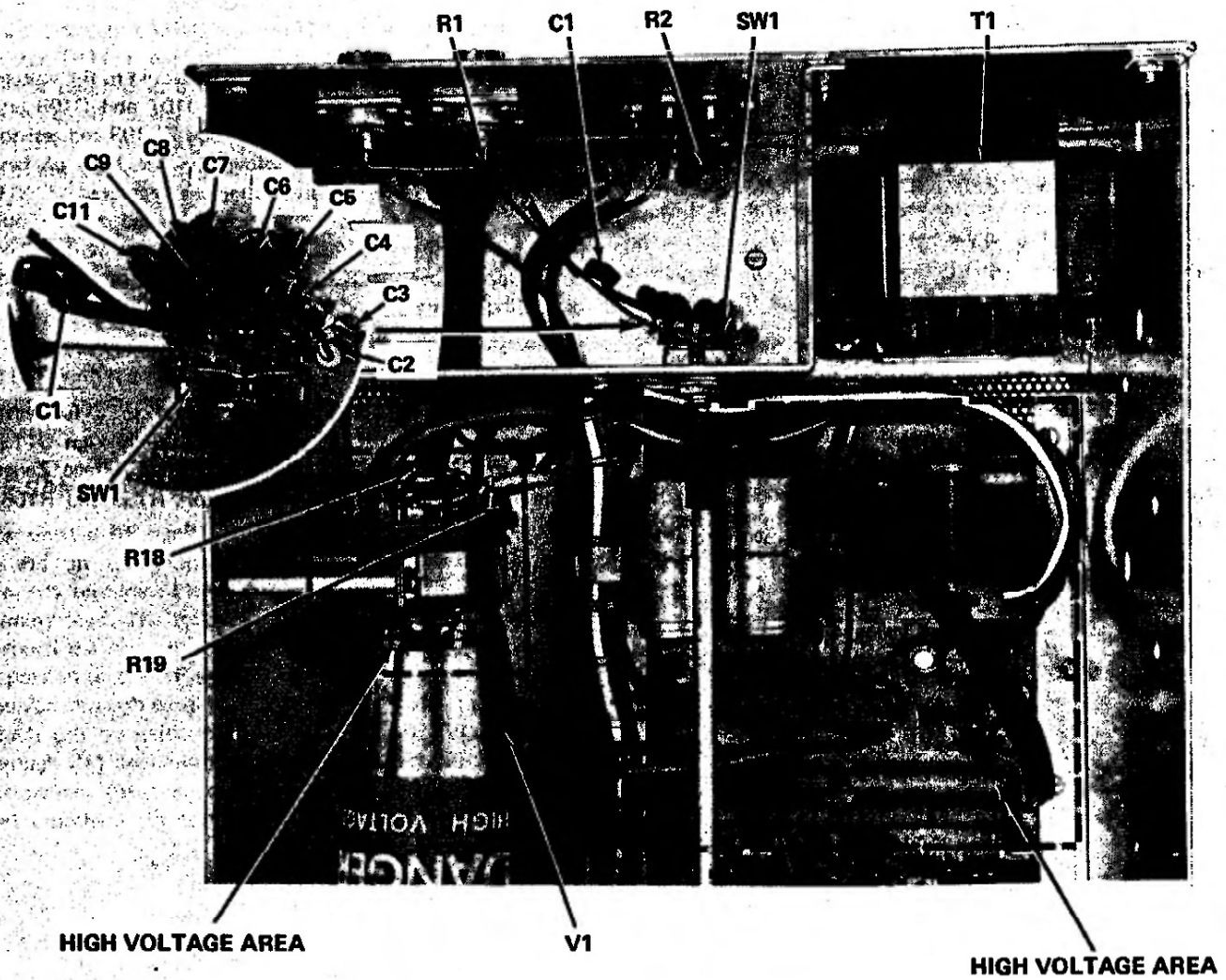

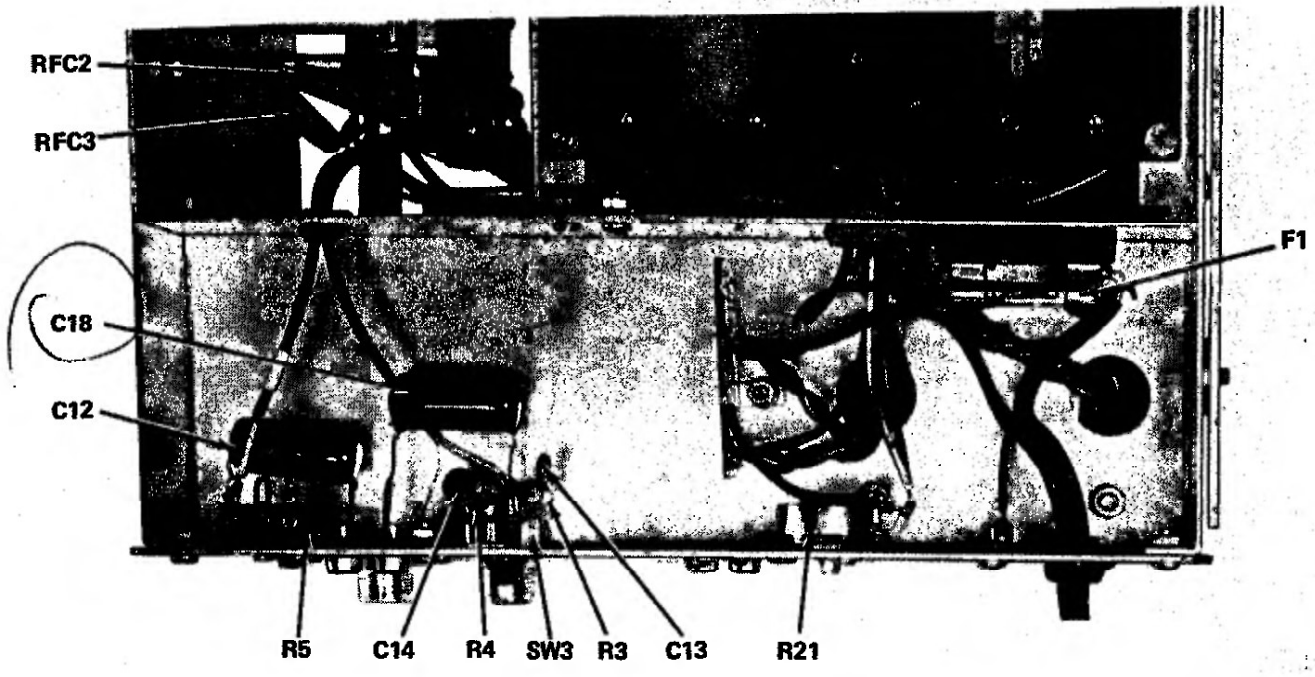
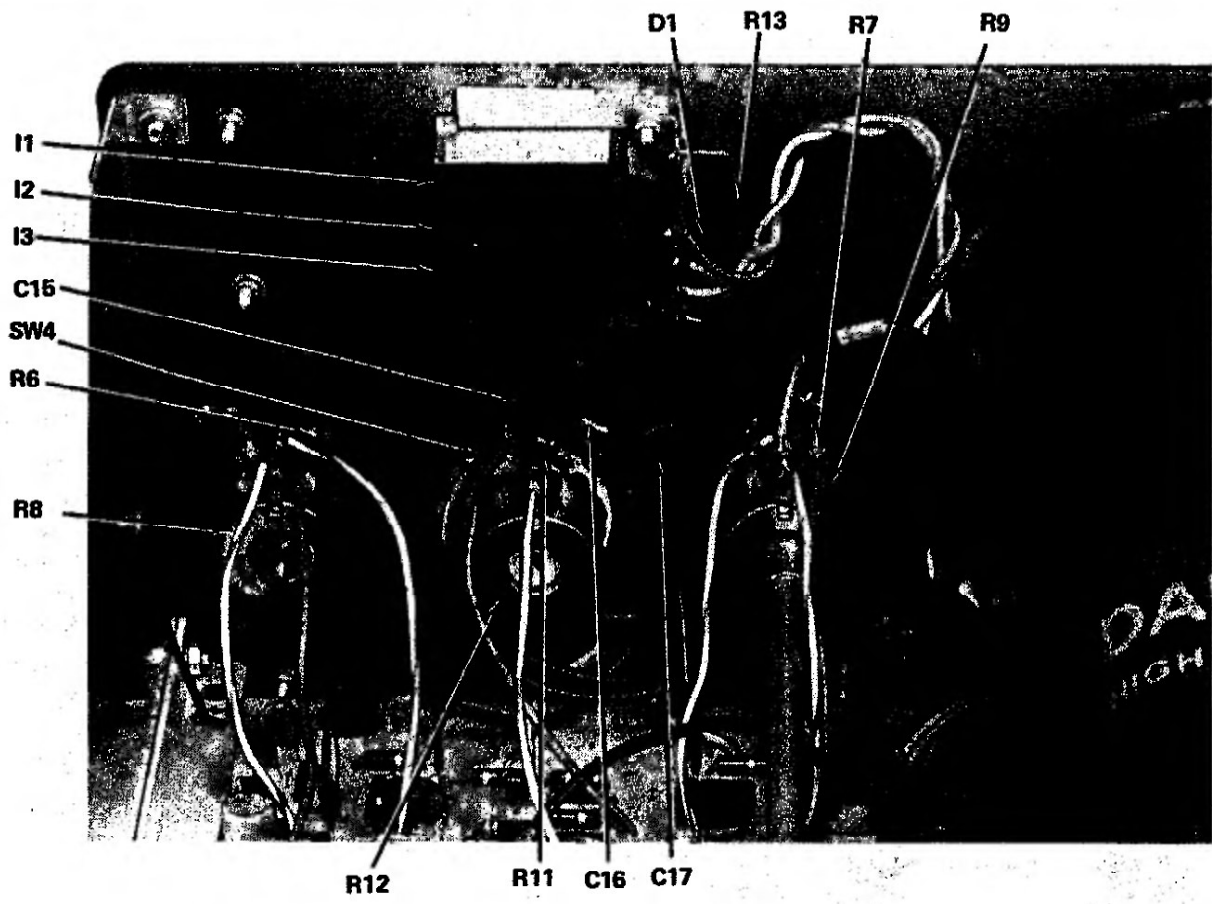

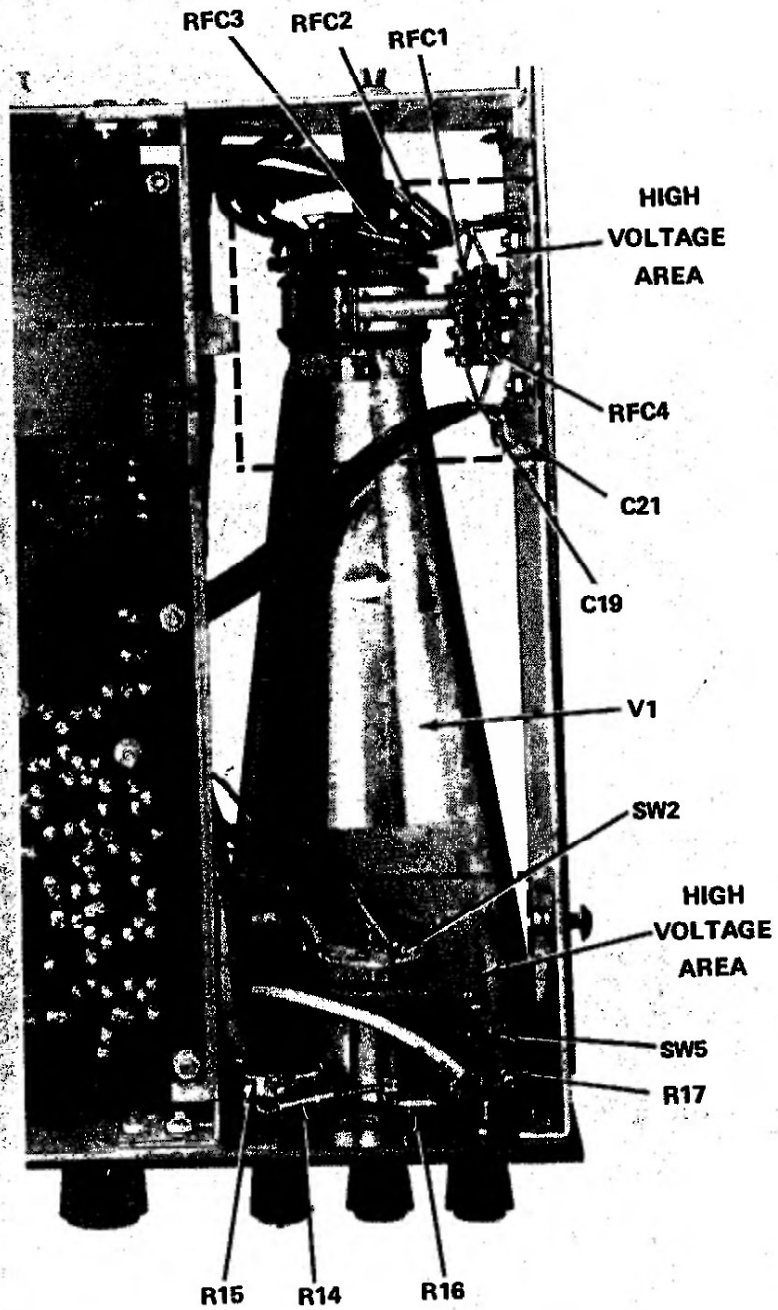

ONT
UT

CIRCUIT BOARD X-RAY VIEWS

NOTE: To find the **PART NUMBER** of a component for the purpose of ordering a replacement part:

- A. Find the circuit component number (R5, C3, etc.) on the "X-Ray View" or "Chassis Photograph."
- B. Locate this same number in the "Circuit Component Number" column of the "Parts List" in the front of this Manual.
- C. Adjacent to the circuit component number, you will find the **PART NUMBER** and **DESCRIPTION** which must be supplied when you order a replacement part.



**DEMODULATOR CIRCUIT BOARD
(SHOWN FROM COMPONENT SIDE)**

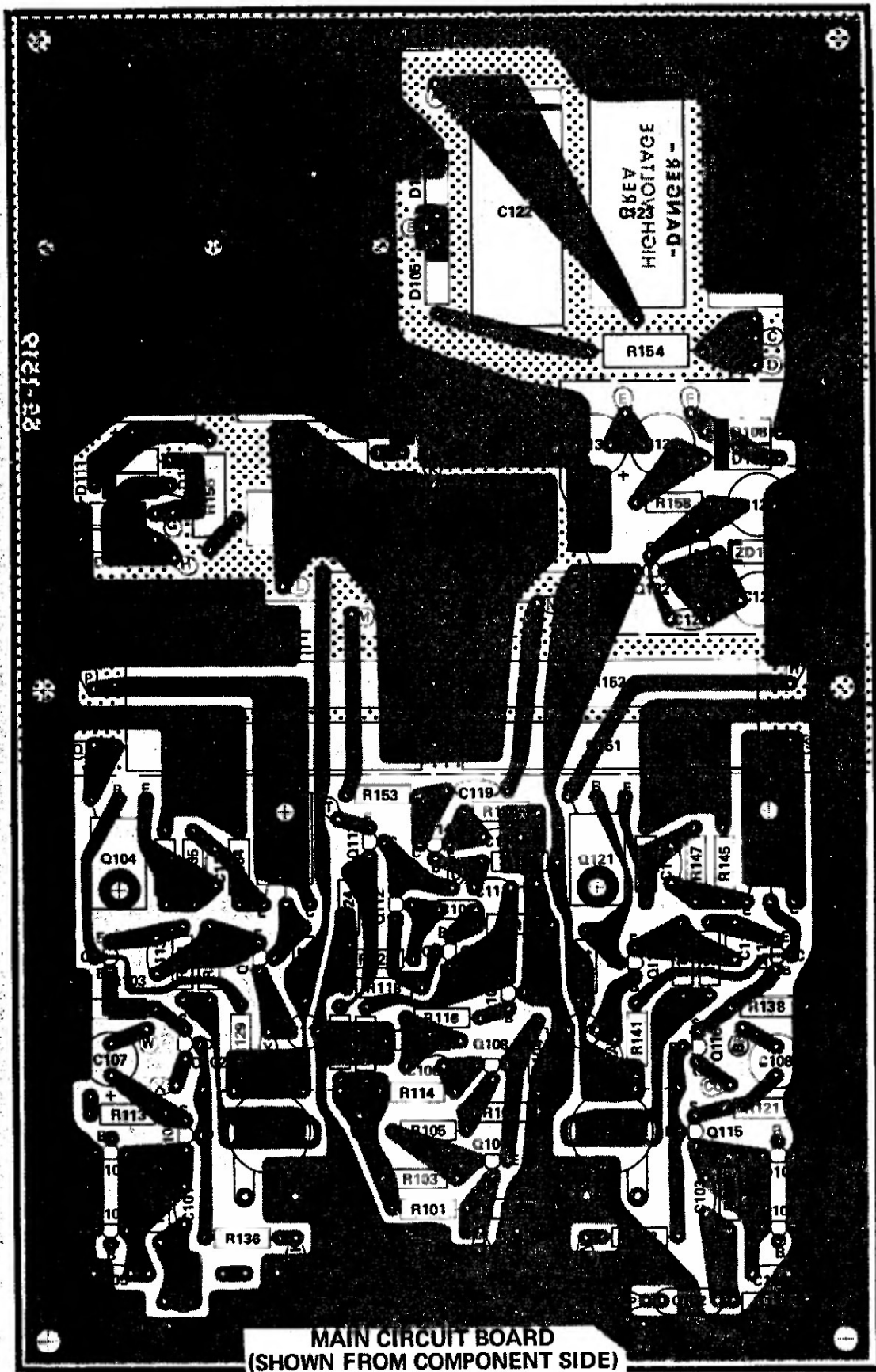

MAIN CIRCUIT BOARD
(SHOWN FROM COMPONENT SIDE)

CIRCUIT BOARD VOLTAGE CHARTS

NOTES:

1. Voltages taken from the point indicated to chassis ground with a high impedance input voltmeter.
2. Voltage readings may vary $\pm 20\%$.
3. Refer to the Schematic Diagram Notes for settings of switches and controls, and for voltage symbols.
4. *This voltage may vary from 0 to -9 VDC (maximum), depending on the level of RF at the antenna input jacks.

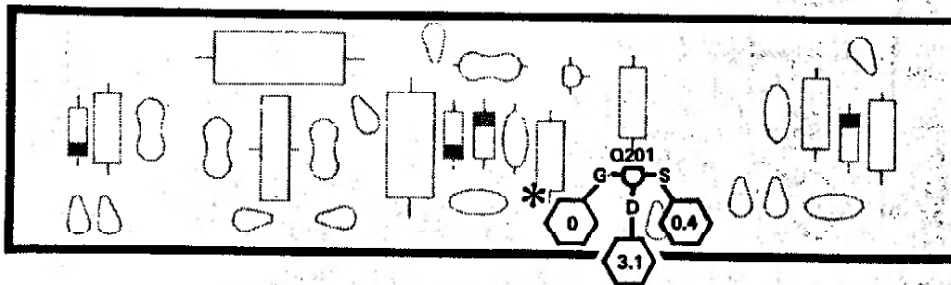

DEMODULATOR CIRCUIT BOARD
(SHOWN FROM COMPONENT SIDE)

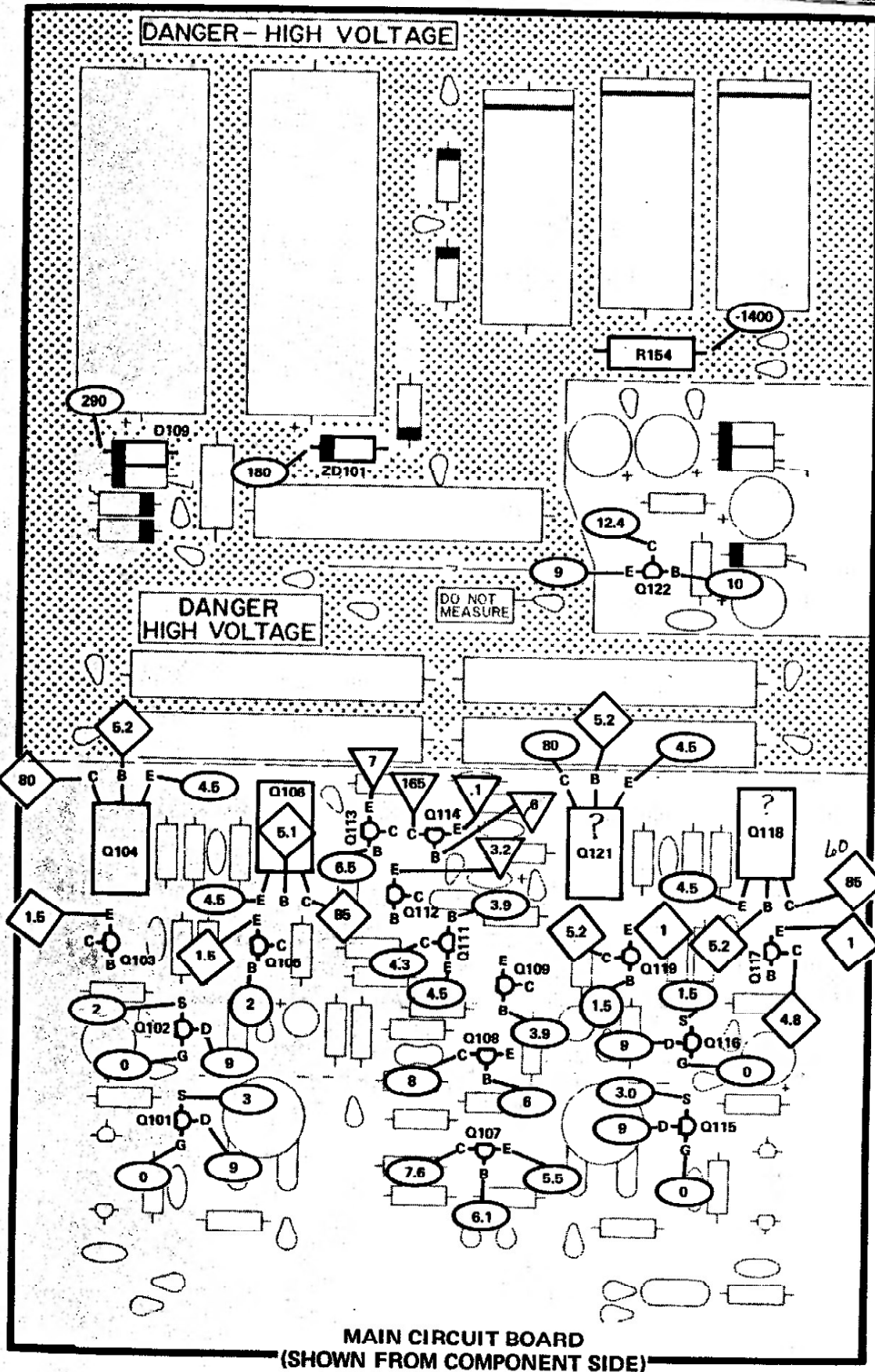

TRANSISTOR IDENTIFICATION CHART

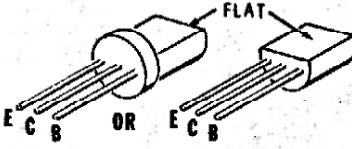
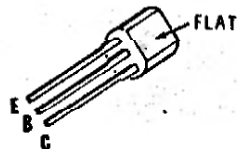
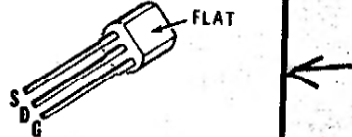
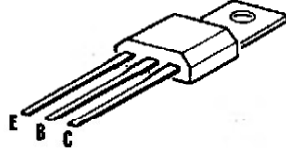
COMPONENT	HEATH PART NO.	MAY BE REPLACED WITH	IDENTIFICATION
Q103, Q105, Q117, Q119	417-91	2N5232A	
Q122	417-94	2N3416	
Q109, Q111, Q112, Q113	417-201	X29A829	
Q114	417-294	MPSA42	
D101, D102, D103, D104, ZD201, Q107, Q108	417-801	MPSA20	
Q101, Q102, Q115, Q116	417-169	MPP105	
Q114	417-291	2N5458	
Q104, Q106, Q118, Q121	417-834	MPSU10	

Check for motor

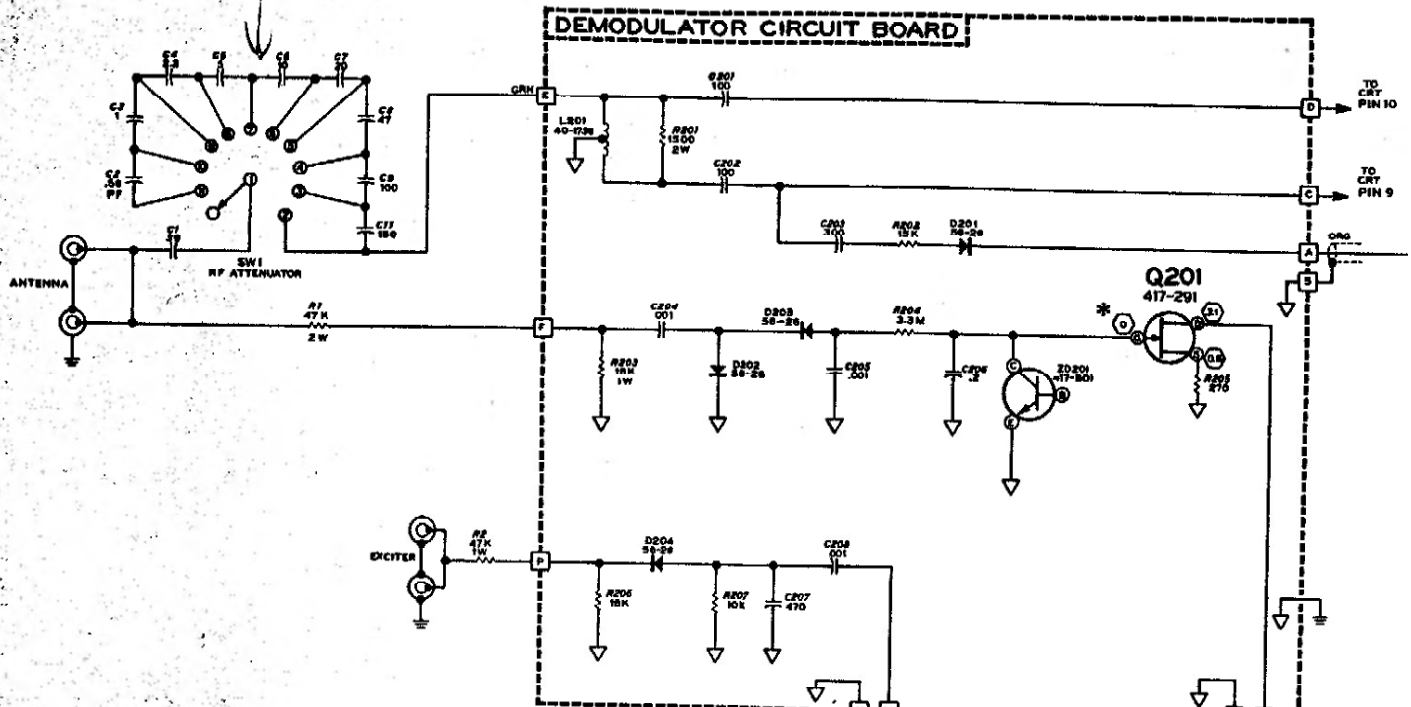

**SCHEMATIC OF THE
HEATHKIT®
SB-814
STATION MONITOR**

NOTES:

1. ALL RESISTORS ARE 1/2 WATT UNLESS OTHERWISE NOTED. RESISTANCE VALUES ARE IN OHMS (K=1000, M=1,000,000).
2. CAPACITORS LESS THAN ONE (.01, ETC.) ARE IN μ F. ALL OTHER CAPACITORS ARE IN pF UNLESS OTHERWISE NOTED.
3. VOLTAGES WERE MEASURED WITH A HIGH IMPEDANCE INPUT VOLTMETER FROM THE POINT INDICATED TO CHASSIS GROUND. VOLTAGES MAY VARY $\pm 10\%$.
4. THE FOLLOWING SYMBOLS INDICATE DC VOLTAGES MEASURED UNDER VARYING CONDITIONS; GENERALLY, MODE SWITCH IN CROSS POSITION, NO SIGNAL INPUT, SPOT CENTERED ON CRT.
 - THIS SYMBOL INDICATES NORMAL DC VOLTAGE.
 - ◇ THIS SYMBOL INDICATES VOLTAGES THAT VARY WITH SETTINGS OF BALANCE CONTROLS.
 - THIS SYMBOL INDICATES VOLTAGES THAT VARY WITH SETTINGS OF POSITION CONTROLS.
 - THIS SYMBOL INDICATES VOLTAGES MEASURED WITH MODE SWITCH IN TRAP POSITION, NO RF INPUT SIGNAL.
 - ▽ THIS SYMBOL INDICATES VOLTAGES THAT VARY WITH SETTINGS OF SWEEP CONTROL AND RANGE SWITCH, MODE SWITCH IN SSB POSITION.
5. ▽ THIS SYMBOL INDICATES A CIRCUIT BOARD GROUND.
6. ≡ THIS SYMBOL INDICATES A CHASSIS GROUND.
7. □ THIS SYMBOL INDICATES A CIRCUIT BOARD CONNECTION.
8. + THIS SYMBOL INDICATES THE CLOCKWISE ROTATION OF CONTROLS.
9. LETTER-NUMBER DESIGNATIONS FOR RESISTORS, CAPACITORS, ETC., HAVE BEEN PLACED IN THE FOLLOWING GROUPS:
 - 1 - 99 CHASSIS MOUNTED COMPONENTS.
 - 101 - 199 MAIN CIRCUIT BOARD COMPONENTS.
 - 201 - 299 DEMODULATOR CIRCUIT BOARD COMPONENTS.
10. * (Q201) THIS VOLTAGE MAY VARY FROM 0 TO -9VDC, DEPENDING ON THE THE RF LEVEL ON THE ANTENNA INPUT JACKS.

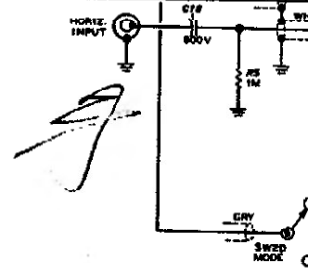
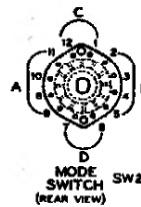

L201 R261

MAIN CIRCUIT BOARD

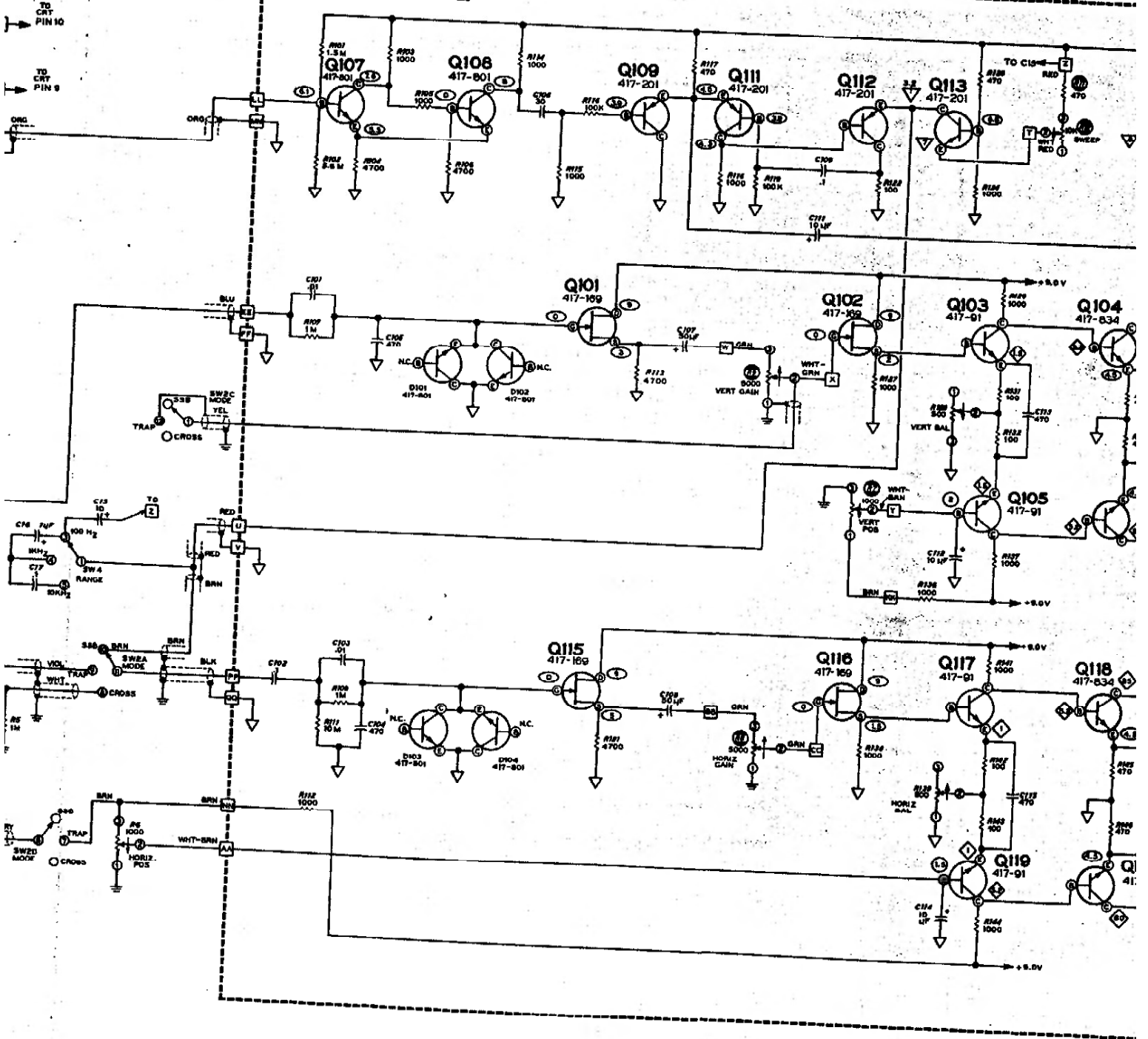

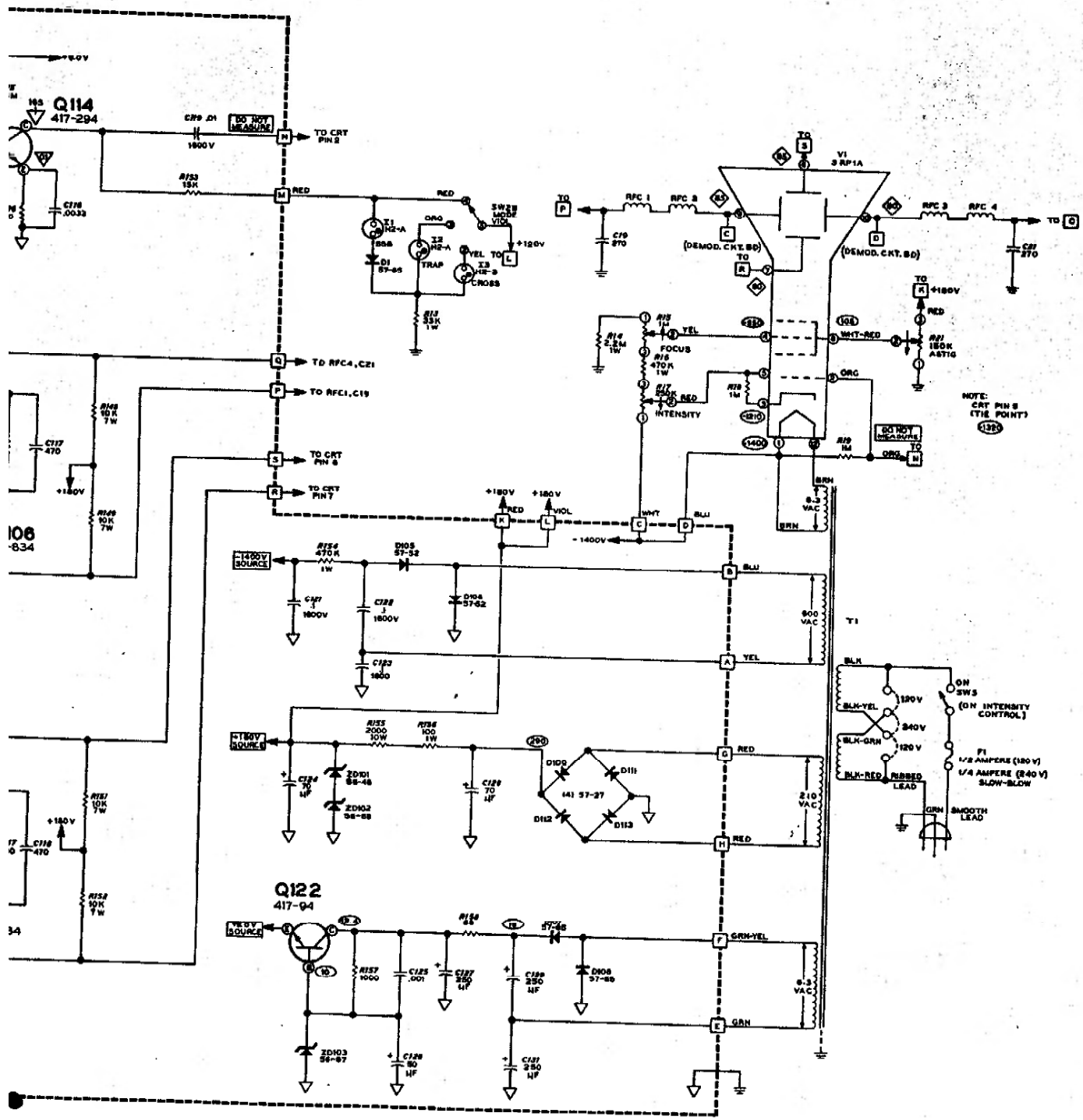

NOTE: CRT PIN 8 (TIE POINT) (12K)

106
834

34