

ACCESSORIES

FOR NSM-PHONOGRAPHS

ES IV-CD TECHNOLOGY

TO
Technical Information, Assy

174 903	SILVER CITY
174 831	SILVER SKY
174 486	FASCINATION
175 274	SOUNDMASTER
175 040	FIRE BIRD/COUNTRY

NSM
Aktiengesellschaft
Saarlandstraße 240
6530 Bingen am Rhein

15

Page 1501-1515

INDEX

- 1 MICROPHONE with paging switch
- 2 REMOTE CONTROL WALL BOXES
- 3 REMOTE CONTROLS
 - 3.1 Infrared remote control
 - 3.2 Remote control with cable
- 4 TAPE RECORDER CONNECTION CABLE
- 5 OUTPUT TRANSFORMER with cable
- 6 DATAPRINT
 - 6.1 Data transfer and memorizing
 - 6.2 Printout
- 7 CD-AUDIO CONNECTION
 - 7.1 Installation in NSM-STAND PHONOGRAPHS
 - 7.2 Installation in NSM-WALL PHONOGRAPHS
- 8 INTERFACE PCB CD 100 - RS 232
 - 8.1 The following commands are understood and executed
 - 8.2 Acknowledgements
 - 8.3 Transfer Format
 - 8.4 Connection Plan
 - 8.5 Power Supply
- 9 DOLLAR BILL ACCEPTOR -ARDAC MINI- (only for USA)
 - 9.1 Installation instructions for Dollar Bill Acceptor in Stand Phonographs
 - 9.2 Installation instructions for Dollar Bill Acceptor in Wall Phonographs

1 MICROPHONE with Paging Switch

Part-No. 224 223

Connection via microphone socket to the central unit.
Microphone announcements are possible in any phonograph mode.

The microphone amplifier with electronic switch-over is integrated into the central unit.

The volume for the background music and microphone can be adjusted separately in the central unit.

Connection cable with plug and microphone socket-length 10 m or 25 m (Part-No. see Spare Parts List in "Technical Instructions").

2 REMOTE CONTROL WALL BOXES

FIRESTREAM	w. Title indication I	FIRE STORM	w. Title indication II
CARAVELLE I	w. Title indication I	CARAVELLE II	w. Title indication II

For connection to NSM phonographs in CD technology. Connection Adapter belongs to the equipment. (Part-No. see Spare Parts List in "Technical Instructions"). Detailed installation instructions are included in the adapter kit.

3 REMOTE CONTROLS

3.1 Infrared Remote Control

Wireless remote control consisting of transmitter, receiver and parts for installations. See wiring diagram for connections.
(Part-No. see Spare Parts List in "Technical Instructions").

3.2 Remote Control with Cable

The connection points are illustrated in the wiring diagram and described in unit description "REMOTE CONTROL".
(Part-No. see Spare Parts List in "Technical Instructions").

4 TAPE RECORDER CONNECTION CABLE

Connection for tape recorders with DIN input and output.
Connections for additional amplifier.
(Part-No. see Spare Parts List in "Technical Instructions").

5 OUTPUT TRANSFORMER with cable.

Significantly expanded adaptation capabilities and low line losses with 70 V output. (See Unit description "OUTPUT TRANSFORMER").
(Part-No. see Spare Parts List in "Technical Instructions").

6 DATAPRINT

The printer is intended for connection to NSM phonographs ES IV-CD Technology. A detailed description is included with the printer. Putting in the paper roll and color ribbon are described in detail in the "TECHNICAL INSTRUCTIONS" for the DATAPRINT.

6.1 Data Transfer and Memorizing

- Turn on service program by opening cabinet and pull out cabinet switch manually, Display 1 "P01".
- Put in printer connector into "Service Socket" of the Control Unit.
- Enter "C", Display 1 "P".
- Enter "11" and "H", Display "P11".
- Enter Code "1" and "H".

Counters P03 to P08 as well as popularity are transferred.

Note: Display 3 "E0" appears if an error occurs during data transfer. Counters P03 to P08 as well as popularity are reset after successful data transfer.

6.2 Transfer to Printer

- Switch on service program by opening cabinet; if needed, pull the cabinet switch manually, Display 1 "P01".
- Plug printer connector into socket of Control Unit.
- Enter "C", Display 1 "P".
- Enter "12" and "H", Display 1 "P12".
- Enter code for the desired print-out and press "H".
 - "1" and "H" = Counters (P03 to P08)
 - "2" and "H" = Counters and settings (P03 to P08, P21 to P37, P39)
 - "3" and "H" = Counters and popularity (P03 to P08, P01, P02)
 - "4" and "H" = Counters, settings and popularity (P03 to P08, P21 to P37, P39, P01, P02).

Note: When a popularity counter has reached value 200, all popularity counters are divided by half of the amount. After dividing the popularity printed out is relative; the number of divisions appears in the printout: "RELATIVE 000" to "xxx".

If the printer does not start, "E0" appears in Display 3.

DATAPRINT

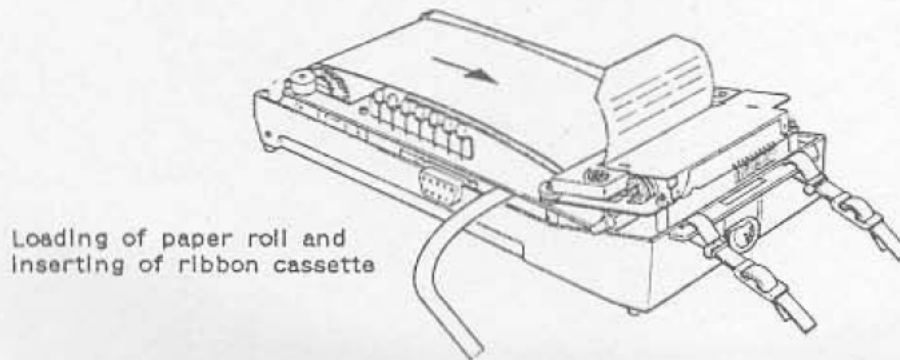
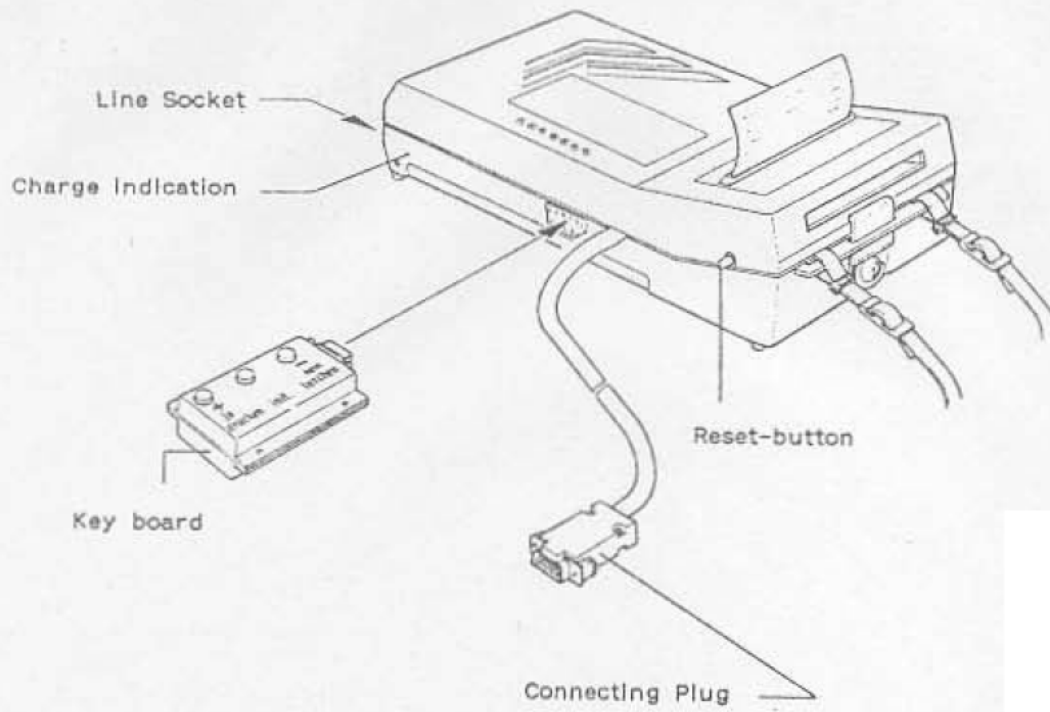

7 CD-AUDIO CONNECTION

To connect an amplifier directly to the output of the CD changer an PCB CD-AUDIO (Part-No. 174 648) is available.

The NF cable on the AUDIO PCB is to be plugged into the "CD" plug of the Central Unit. The cable from the CD changer is to be plugged into the PCB "CD-AUDIO".

The CD AUDIO PCB is to be fastened with 4 distance holders. The following sketches show possible mounting points.

Ground has to be connected to the metal housing or with wood housings to the next grounded piece of metal.

To connect the external amplifier to the CD AUDIO high-grade connecting cables with RCA plugs on both ends are available.

Stereo cable set (2 m) Part-No. 227 533

7.1 Installation in NSM-Stand Phonographs

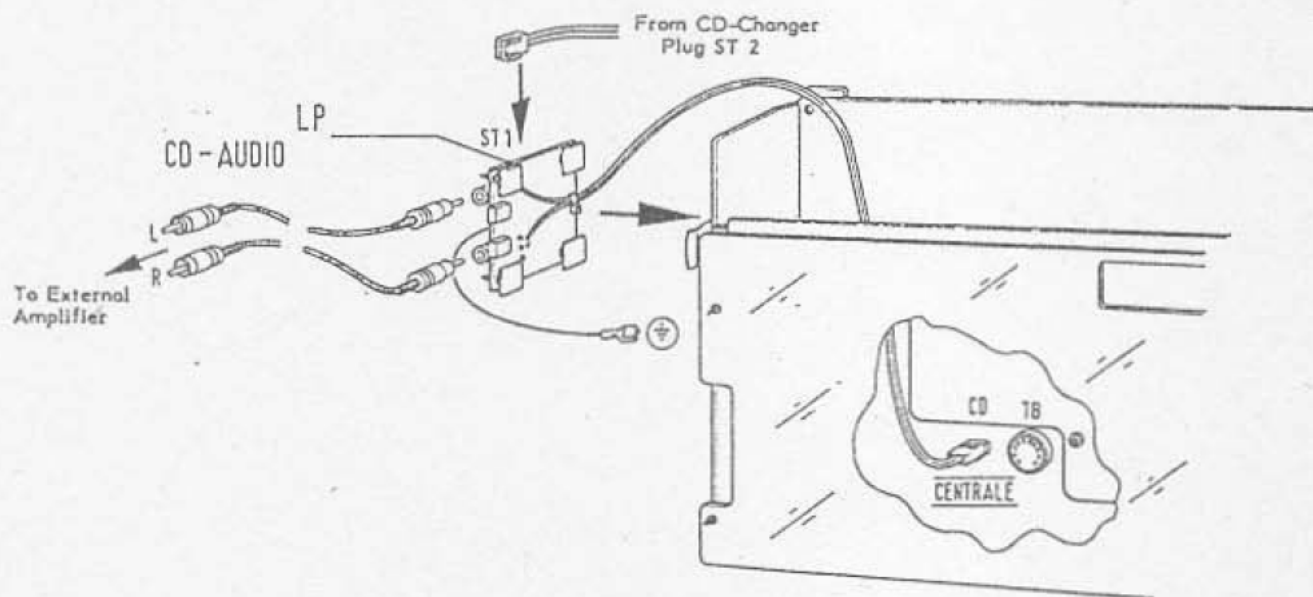

7.2 Installation in NSM-Wall Phonographs

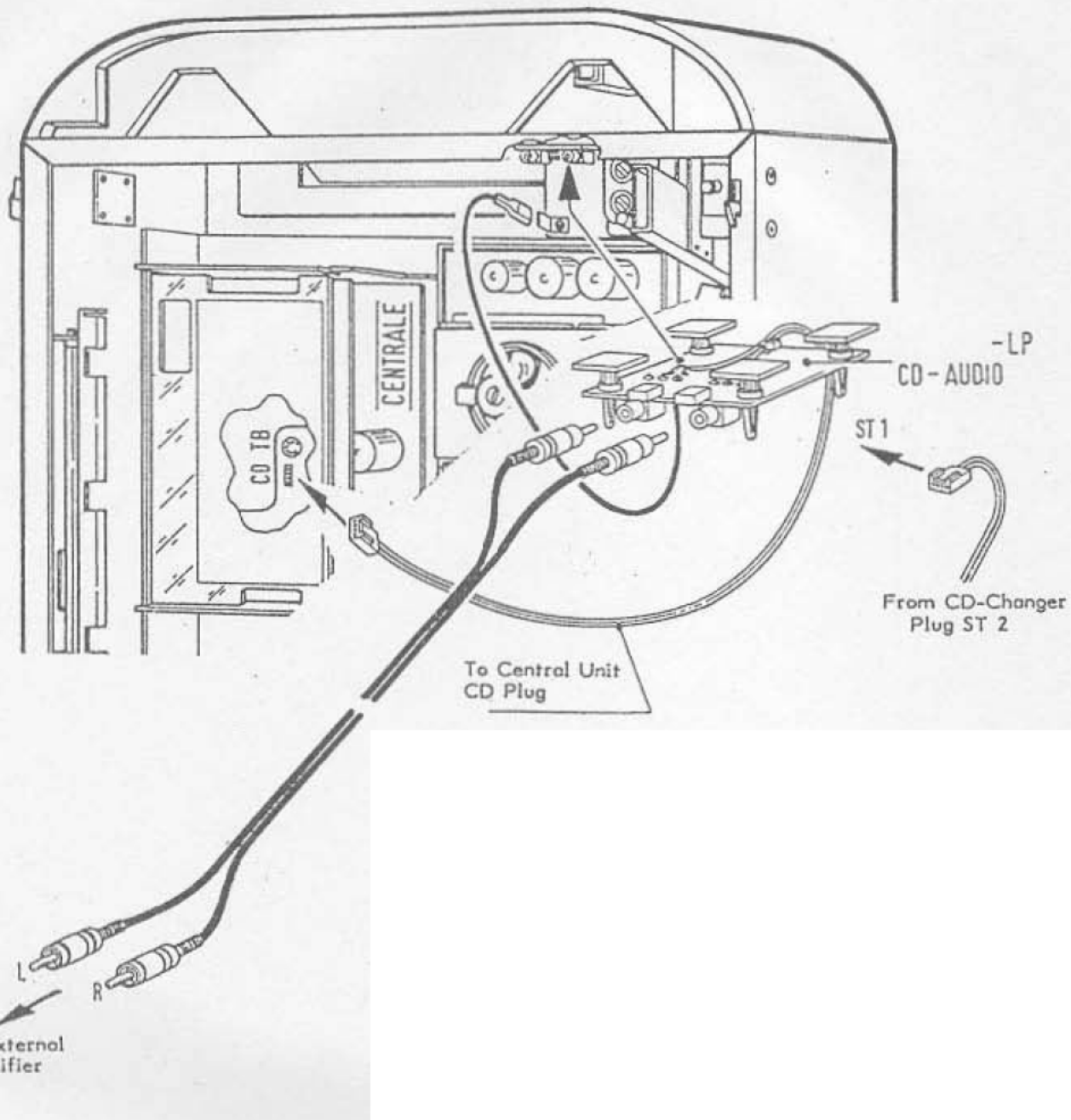

8 INTERFACE PCB CD100-RS 232 FOR NSM CD CHANGER

With the newly developed interface PCB CD100-RS 232 NSM phonographs can be controlled and evaluated with almost any computer.

8.1 The following commands are understood and executed:

10-key keypad 0 to 9	- Selection via keypad
B	- Background
C	- Selection as via keypad
D	- Display request
F	- Free credit
H	- Selection as via keypad
M	- Muting
R	- Reject
U	- Vol I -
V	- Vol I +
W	- Vol II -
X	- Vol II +
Y	- Vol I/II -
Z	- Vol I/II +

8.2 Acknowledgements:

Wrong commands ?x (x = incorrectly received command)
D (display read-out) !VWWWYYZZZZ
V = lighting status = 010vvvv
 :::+- L1 error-press C
 ::+-- L2 your selection
 ::+--- L3 credit
 :+---- L4 10 top hits
 +----- L5 background plays
W = in ASCII disc/track of playing title
Y = in ASCII credits
Z = just selected title or chart in ASCII

(WWWYYZZZZ correspond to display of
phonographs).

8.3 Transfer Format:

RS 232 with V 24 drivers, 1200 Bd, 1 start bit, 8 data bits, 1 stop bit, no parity handshake via CTS and DTR no XON/XOFF, RTS is not evaluated, DCD is not connected, DSR is always on + 10 volt.

8.4 Connection Plan:

1 free (DCD), 2 TX, 3 RX, 4 DTR, 5 GND, 6 DSR7 free (RTS), 8 CTS, 9 free.
To connect to the 9-pole RS 232 plug of an AT compatible PC, a 1:1 connection with plug/socket (i.e. monitor extension cable, flat wire) is sufficient.

8.5 Power Supply

Supply (via keypad connection on CD box) 8 to 12 volt, 0,25 A.

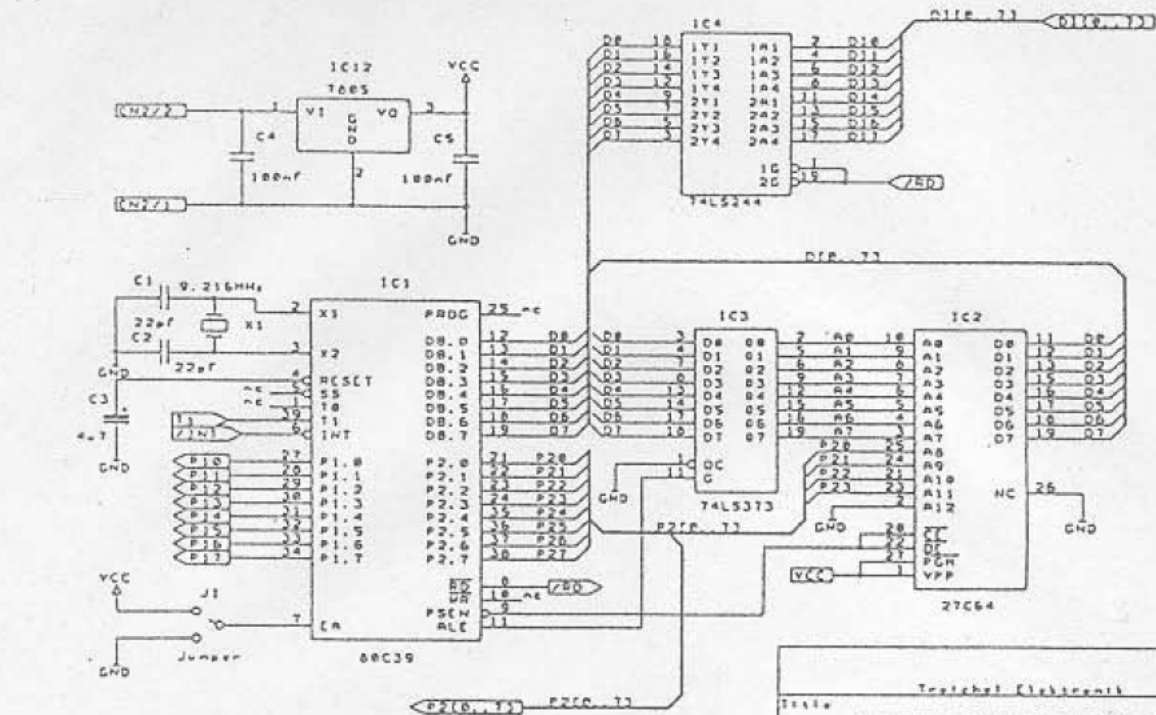
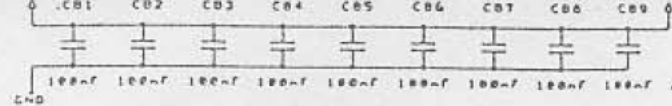

Toscheb Elektronik		
Titel: Serielle Schnittstelle CD-Fire		
Size Document Number	80C39-1	REV 1.0
Date: Dezember 6. 1989 Sheet 1 of 3		

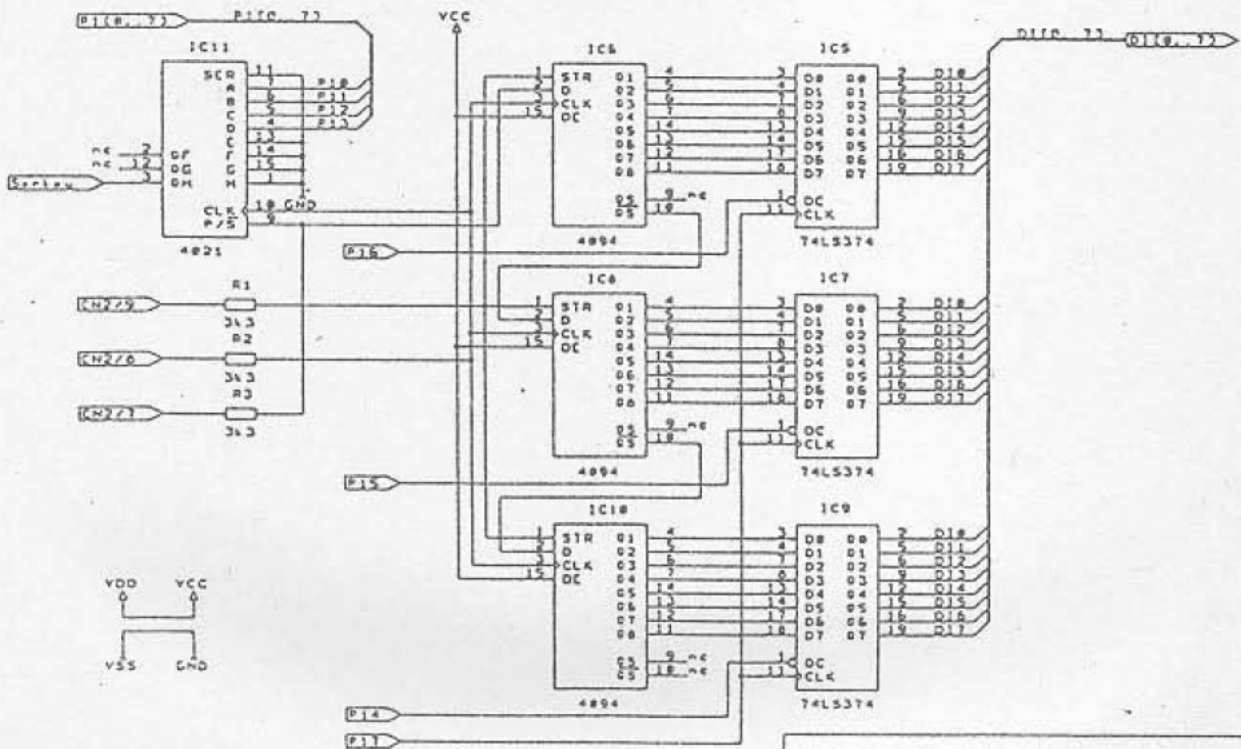

Toscheb Elektronik		
Titel: Serielle Schnittstelle CD-Fire		
Size Document Number	80C39-2	REV 1.0
Date: Dezember 6. 1989 Sheet 2 of 3		

Schematics of interface PCB

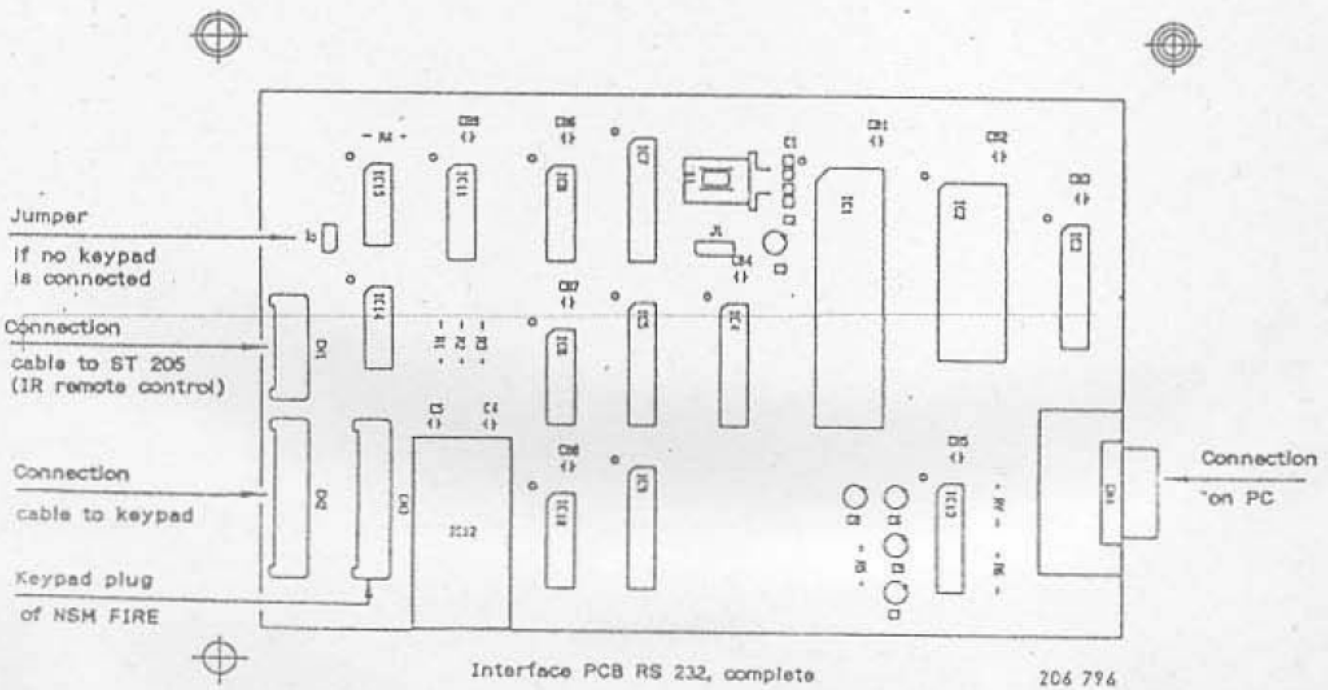
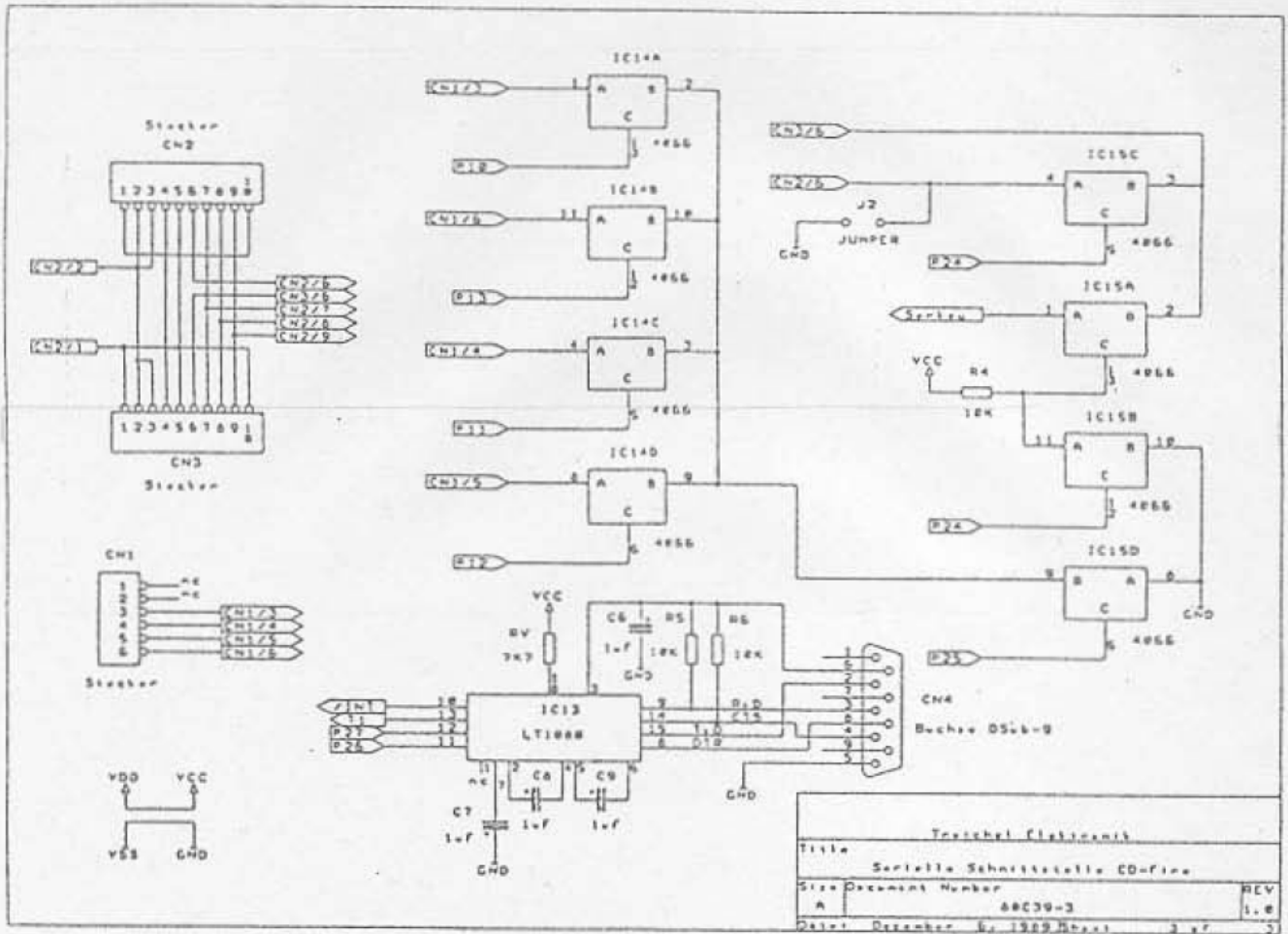

CHUTE
SIDE VIEW

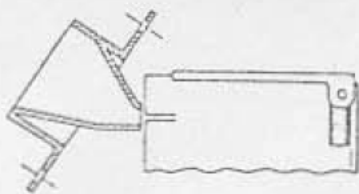

Fig. 1

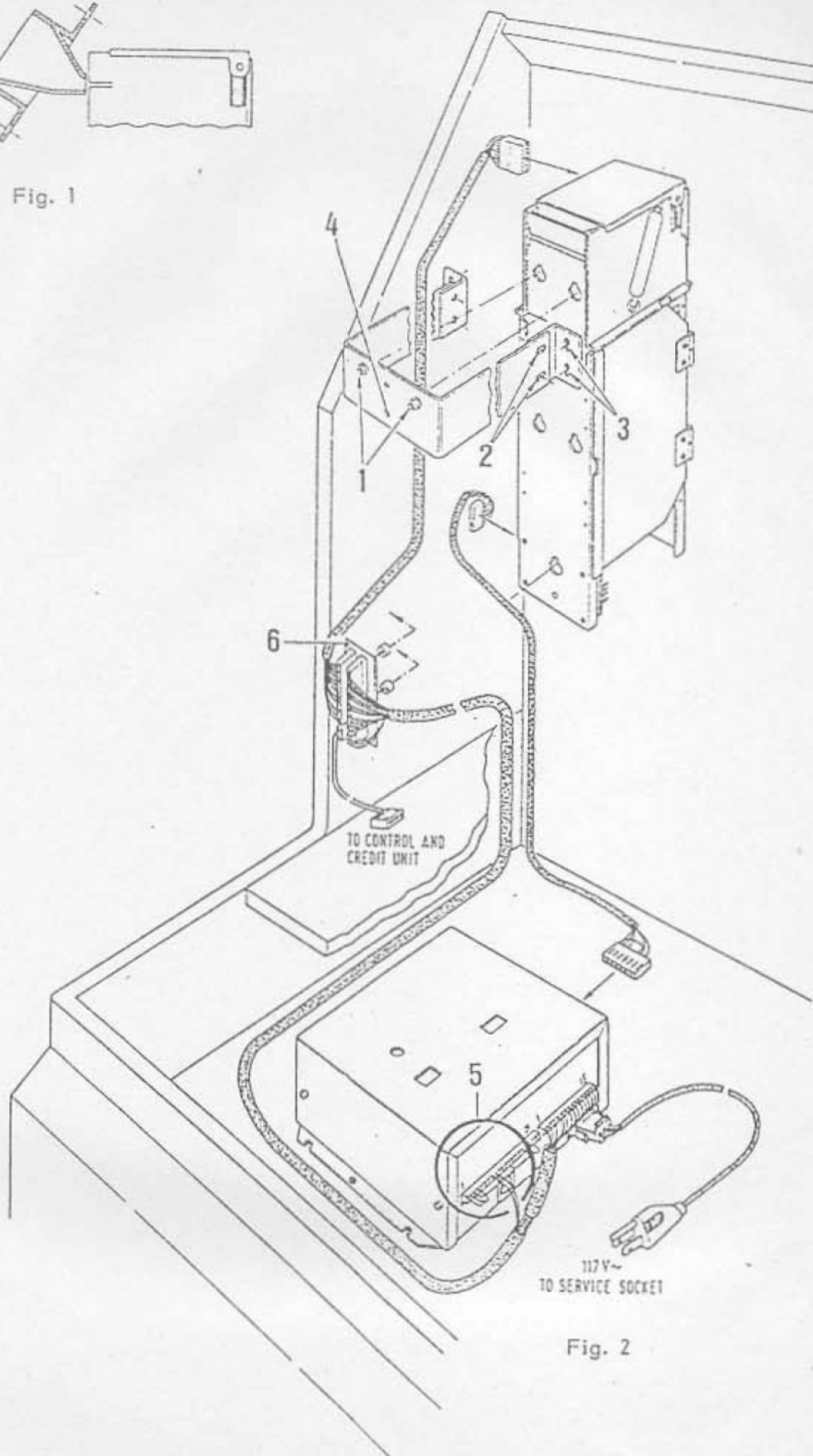
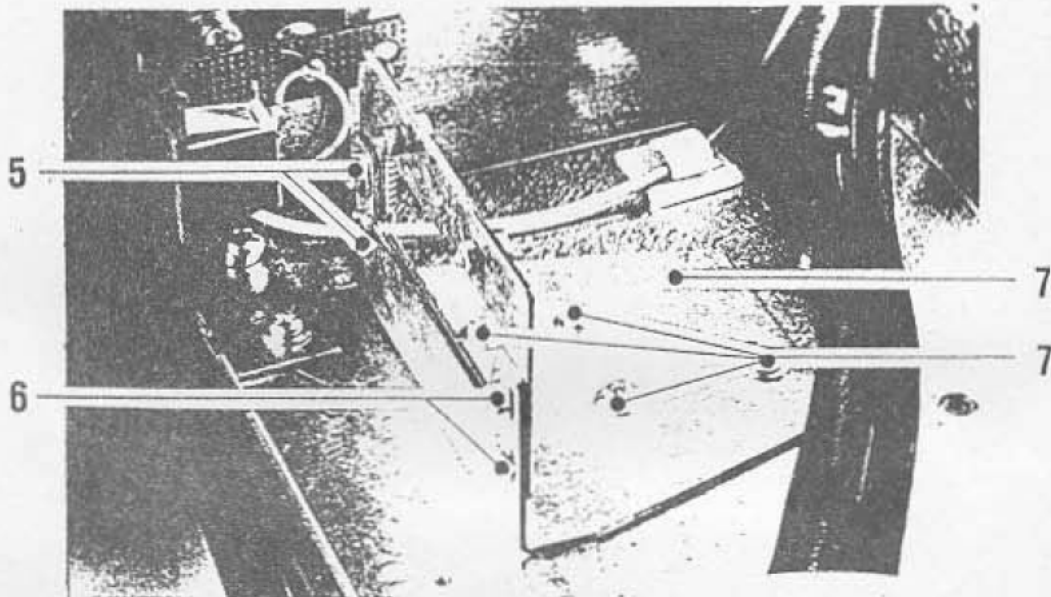
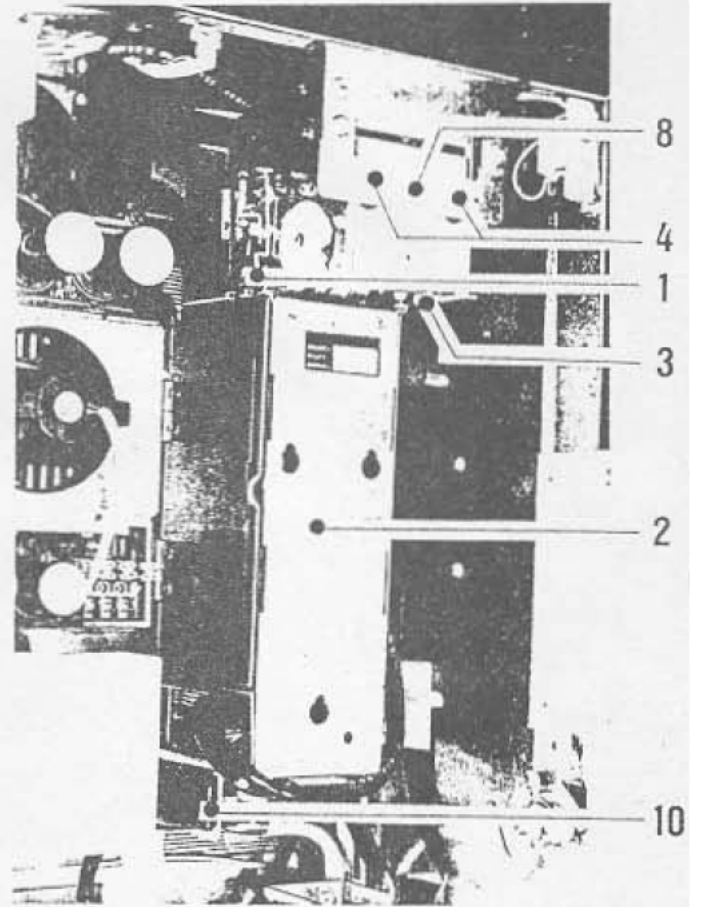
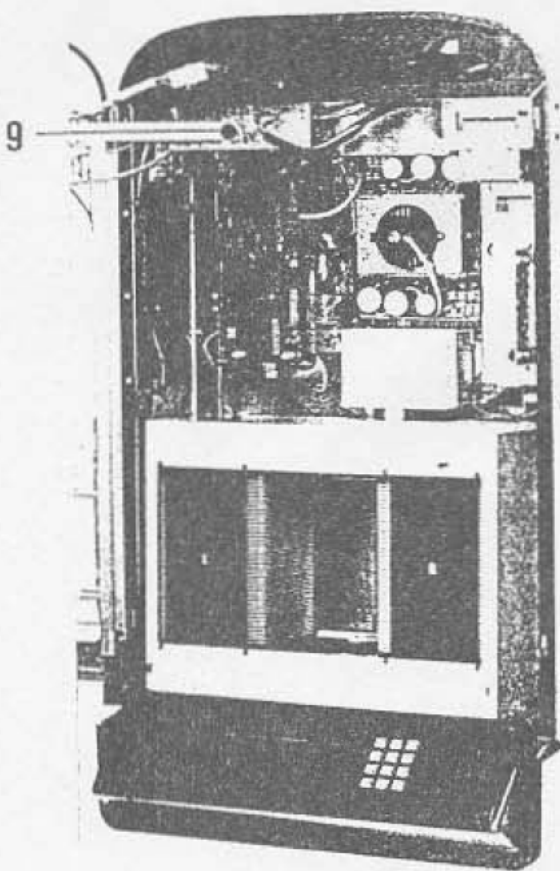

Fig. 2

9 DOLLAR BILL ACCEPTOR -ARDAC MINI- (only for USA)

9.1 Installation Instructions for Dollar Bill Acceptor in NSM CD-Stand Phonographs.

- Install chute in place of cover in lid (see Fig. 1).
- Hang dollar bill validator into the 2 attachment studs (Fig. 2 / Pos. 1).
The unit must be installed so that it does not interfere with the lid when closing - however, the chute must close tightly to the dollar bill validator.
The depth can be adjusted at Fig. 2 / Pos. 2.
The height should be adjusted at Fig. 2 / Pos. 3 so that the dollar bill validator is aligned with the chute in the lid and is guided exactly into the acceptor slot (Fig. 1).
Secure dollar bill validator with sheet metal screws F 3.9 x 6.5 at Fig. 2 / Pos. 4.
- Install dollar bill adapter PCB (Fig. 2 / Pos. 6) on 2 spacers with wood - screws to the left inside of cabinet.
- Put 2 contacts from the harness (as can be seen in Fig. 2 / Pos. 5) into Plug Housings 6 and 7 of the 21-pole plug.
- Mount dollar bill electronic (control box) as shown in illustration.
- Make plug connections from dollar bill adapter PCB to the acceptor to the control unit and to the control box; plug connection cable from control box into plug; plug in control box into service socket.
- Program price setting (plays/monetary value) in program step 45, e.g. "07 100" = 7 plays / 1 dollar).
- Program monetary value in Program Step 45, e.g. "07 100" = 7 plays / 1 dollar.
- Program monetary value for Channel 5 in Program Step 55; e.g. "100" = 1 dollar.



9.2 Installation instructions for Dollar Bill Acceptor in NSM CD-Wall Phonographs

- Pull up latch (Pos. 1) and adjust staker (Pos. 2) so it is positioned vertically under the acceptor (Pos. 3).
- Hang dollar bill validator into the 2 studs (Pos. 4). The unit must be installed so that it does not interfere with the lid when closing - however, the chute must close tightly to the dollar bill validator. The depth can be adjusted by loosening the three screws (Fig. 5) and by moving the bracket. The height can be adjusted by loosening the four screws (Fig. 7) and moving in a vertical direction; bill validator must be aligned with the chute in the lid and guided exactly into the acceptor slot.
- Secure dollar bill with screw M 4 at Pos. 8.
- Move staker backwards into its final position until the latch (Fig. 1) locks in at the second position.
- Put the 2 contacts from the harness, as seen in Pos. 9, into plug housings 6 and 7 of the 21-pole plug.
- Mount dollar bill electronic (control box), as shown in illustration, at the top of the cabinet. First push it into rear guide studs, then mount the front side with two screws. The plastic discs serve as spacers between the control box.
- Make plug connections to the acceptor, to the staker and to the control box. Plug power plug from control box into service socket (Fig. 10).
- Program price setting (plays/monetary value) in program step 45, e.g. "07 100" = 7 plays / 1 dollar.
- Program monetary value for channel 5 in program step 55, e.g. "100" = 1 dollar
- Lay harnesses so that they do not hinder other units!

UNIT DESCRIPTION
CD CHANGER
FOR NSM-PHONOGRAPHS

ES IV-CD TECHNOLOGY

to
Technical Information, Assy

174 903	SILVER CITY
174 831	SILVER SKY
174 486	FASCINATION
175 274	SOUNDMASTER
175 040	FIREBIRD/COUNTRY
176 046	THE PERFORMER "GRAND"

NSM
Aktiengesellschaft
Saarlandstraße 240
6530 Singen am Rhein

8

Page 801-815/821-822

INDEX

- 1 PICKUP FUNCTION
 - 1.1 Transport
 - 1.2 Pull holder
 - 1.3 Return holder
 - 1.3.1 Feature

 - 2 PICKUP DRIVER
 - 2.1 Lift control
 - 2.2 Grip control
 - 2.3 CD-Player control

 - 3 PLAYER
 - 3.1 Disc player CDM 3
 - 3.2 Servo panel

 - 4 PCB DECODER BOARD

 - 5 MAGAZINE

 - 6 CD CHANGER 100, test, set, adjust
 - 6.1 GENERAL INFORMATION
 - 6.2 MAGAZINE
 - 6.3 PLAYING UNIT
 - 6.4 LIFT
- Spare parts lists

1 PICKUP FUNCTION

The pickup serves to transport the CD's between the magazines and the player.

ATTENTION! When the CD changer has the switch at the window (upper right), the transport does not function if the window is open.

If the window is opened while the CD is playing, the title will be played to the end, but the CD will only be transported back after the window is closed.

1.1 Transport

The lift is moved via a stepping motor controlled by the microprocessor of the control unit. The distance between 2 CD slots is 8 motor steps (1 opto counter step).

During the run the light barrier OPTSP, which is directly connected to the drivewheel, checks the motor's position every 4 steps. Stepping errors are immediately recognized and displayed with Er 75.

Together with the light barrier OPEND the end position of the lift is verified. Should a mistake appear here (signal too late or early) the display shows Er 76.

1.2 Pull Holder

With both grip levers, brought into lock position by CD motors MOGRL for left and MOGRR for right, the CD holders with their CD's are pulled out of the magazine. The light barrier OPPUM reports the correct position of the CD holder in the pickup unit.

If there is no report 2 sec. after switching on the motor, the display will show Er 71 for the left magazine or Er 72 for the right magazine.

1.3 Return Holder

To return a CD holder to its magazine, either motor MOGRL for the left magazine or MOGRR for the right magazine is switched on in the opposite direction.

Light barriers OPGRL or OPGRR report the end position of the grips.

If the report does not appear within 2 sec. after switching on the motor, the display shows Er 73 for the left magazine or Er 74 for the right magazine.

1.3.1 Feature

If you want the CD to remain on the player after it finishes playing, the solder bridge LB3 on the pickup driver board must be connected.

If the cabinet switch is pulled out, the tray with the CD is returned to the magazine.

2 PICKUP DRIVER

2.1 Lift Control

With output port IC3 the microprocessor of the control unit controls switch transistors T 2-5 via drivers T 6-9. These drive the unipolar coil of the stepping motor (ST4, Pin 1-6). Using signal OPSTP (ST4, Pin 7) the microprocessor controls the position of the motors.

Together with signal OPEND (ST 3, Pin 8) the end position of the lift is reported via input port IC 1.

2.2 Grip Control

Both of the grip motors (MOGRL for the left magazine and MOGRR for the right magazine) are driven from the double motor bridge IC 6 via output port IC 3.

While pulling a CD from the magazine the signal OPPUM (ST 3, Pin 7) reports the end position of the CD holder in the pickup to the microprocessor of the control unit.

While returning the CD it recognizes the end position of the grips via signals OPGRL (ST 3, Pin 5) for left and OPGRR (ST 3, Pin 6) for right.

2.3 Control of the CD Player

Microcomputer IC 8 (T018) is used to convert the incoming serial data in I²C-Bus format from the decoder panel into parallel signals that can be processed.

The microprocessor of the control unit communicates with it via ports IC 4 and IC 2.

3 PLAYER

3.1 Disc Player CDM3

The CDM3 contains the components laser diode, play motor, radial motor, and focus unit.

It reads the data from the CD.

3.2 Servo Panel

The servo panel contains the components to control the CDM3.

They consist primarily of the photodiode signal processor, the radial error processor, the drivers for the laser diode, the focus unit, the radial motor and the playing motor.

4 PCB DECODER BOARD

The components servoprocessor, decoder, digital filter, DA converter and NF output driver are combined on the decoder board. It also contains the circuit to process the complete power supply for decoder board CDM3 and servopanel.

5 MAGAZINES

2 equal magazines that are equipped with 50 CD holders each are in the CD changer. With different CD holders it is possible to play 5- or 3-inch CD's.

The magazine can be swung out and totally taken out.

Equipping with or changing CD's can be done simply by taking out the respective CD holders, inserting the new CD into the holder and pushing it back till locks in the magazine.

6 CD CHANGER 100, test, set, adjust

6.1 GENERAL INFORMATION

Please note the illustration of the CD changer on the last page regarding the following text.

After exchanging units their functions must be checked and, if needed, certain adjustments must be made.

To exchange the playing unit the CD changer can remain in the phonograph. But to remove or install the lift the changer has to be removed from the machine; tests and adjustments are only possible at a bench tester or at the machine with appropriate extensions!

Take care that the changer is set down on supports so that the board disc (12) or the main axle (14) which protrude from the cabinet floor are not pushed inside. Otherwise the board disc will jam the gear (2); a displaced axle changes the position of the upper distance sleeve so that the lift drives against it and blocks!

In service program step P60, Pt. 1.5.5 "Test CD Changer" the grips can be moved left or right with Keys "4"/"5" or "6"/"5" and the lift can be moved up or down with key "2"/"8". With Key 1 the CD player can be started and stopped.

For fine adjustments of the lift position the lift can be moved with Key "3" (+) or "9" (-) one motor step at a time (equals about 0,5 mm height difference) either up or down; this option is available for ES-IV CD phonographs as of Program Index 004.

The distance between two magazine slots is 8 motor steps (or 1 opto step.). In the displays the present status of the respective opto mask and the time in seconds during which the lift position is held are shown.

6.2 MAGAZINE

The magazines in swung-in and locked position are supported by height-adjustable studs. Changing the height setting can be necessary when the lift is exchanged; setting see Pt. 4 "Lift".

6.3 PLAYING UNIT

To exchange the playing unit with CD player

- remove both magazines
- pull lift up on belts
- swing support clamps on chassis of playing unit out
- carefully (!) pick up playing unit, watch balance washers under cabinet
- open plug connections
- Installation of playing unit in opposite sequence
- function test:
 - remove decorative cover (01) and check if axle of suspension plate is in the center of the upper lift bore.
 - choose CD, check if CD is securely clamped in play position.
 - further tests see Pt. 6.4 "Lift".

6.4 LIFT

To exchange the lift as well as to check and adjust the opto coupler of the CD changer, completely remove the CD changer, disconnect cables, remove rear wall.

- From the rear side of the machine pull lift (04) up by the gear belt (02), interrupt connection between lift and gear belt by unscrewing the gear belt lock (03).
 - Pull out plug of connecting cable (06).
 - Remove board disc (12) after removal of washer.
 - Pull distance sleeve (13) at bottom of main axle (14) from cabinet floor upwards; remove securing clamp of main axle from inside of cabinet.
 - Remove securing clamp of guiding axle (10) from inside of cabinet.
 - Pull guiding axle down through floor of cabinet.
 - Push main axle down until upper distance sleeve can be removed.
- If main axle is pulled out all the way, do not mistake upper and lower distance sleeves; they are of different length!
- Remove lift; mount exchange lift in opposite sequence.
 - Function test, basic setting; CD changer must be completely connected to operate either with extensions to phonographs or a bench tester:
 - turn on test program P60/5, "test CD changer" F5. All functions of the changer can be checked, see excerpt of service program below:

If functions of the changer can be tested individually.

CD changer test Enter "5" and "H", Display 2 "F5".

Input	Function
1	CD-Player, Start/Stop
2	Lift, upwardw
8	Lift, downwards
4	Grip left
6	Grip right
5	Return holder
0	Stop lift at magazine space
3	*) Motor steps, upwards (per 0,5 mm)
9	*) Motor steps, downwards (per 0,5 mm)

Keep in mind the code numbers for the individual changer functions as per the following keyboard illustration:

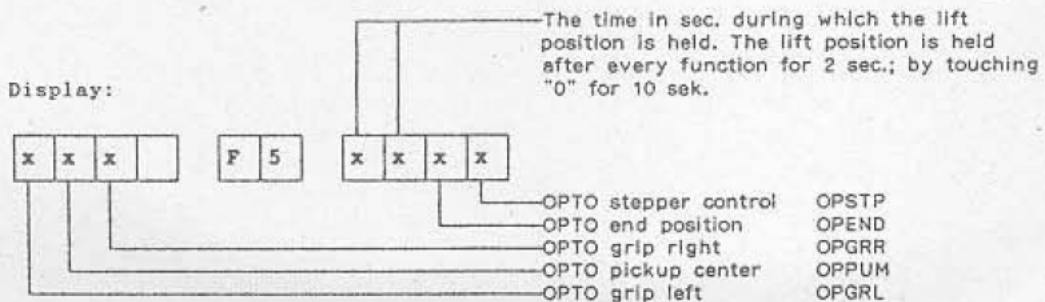
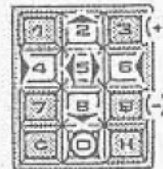

Meaning of displays: OPTO lit up = "0", OPTO darkened = "1".

Terminate test. Actuate housing switch.

*) from Progr.-Index 004

- The basic setting occurs in parked position at Magazine Slot 25/75. Drive pick-up to this position with Keys "2" and "8". The lift is held after each function in this position for 2 sec.; with Key "0" for 10 sec.
- Drive cassette in and out with Keys "4"/"5" or "6"/"5". Check function for smooth movement. The respective grip lever must fall into the cassette w/o hindrance!
- To adjust lift height loosen belt lock and move up or down; then tighten screws!
- Move lift down one motor step (about 0,5 mm height difference) with Key "9" (-); same test for smooth movement.
- Drive to normal park position with key "0" and with Key "3" (+); switch lift one motor step above normal position. Same check for smooth movement.
- Set magazine height: If magazine slots do not align with lift, then adjust lift only to one magazine at first. After that the other magazine is adjusted with support screw (11/15) to the correct height.
- The light barrier (08) on the step motor must be in parked position 25/75 in the center of the opto scanner OPSTP (09) (status display of OPSTP in display = "1"). If necessary, loosen screw on hexagon bolt and set PCB with opto coupler to center of mask.
- To adjust opto coupler OPEND (05) lift must be driven down to bottom. Drive lift upwards with Key "3" (press 4 times) or manually with one half opto step; the mask (16) must release OPEND (05) when OPSTP (09) opens the light mask, displayed by "0". Adjustment done by shifting of light mask angle (16) of OPEND, displayed by transition of "0" to "1" or "1" to "0".
- Select CD in normal program. In the parked position of the playing position the lift must have a gap to the lower end position.
- The distance between a cassette and the clamping dish should be at least 1 mm during a gripping procedure. So that the clamping dish can be magnetically attracted, the decorative cover must be in place.
- The CD must run w/o touch and grinding sounds when in a suspended position.
To test the function get cassette with CD from magazine by pressing correct keys and place it on CD player in play position. Turn on CD player with Key "1". After test with Key "1" or any of the other function test keys turn off CD player. The clamping dish must clamp down on CD exactly in center.
- Check function of fork light masks OPGRR, OPGRL, OPPUM as per test "F5". The respective mask must cover the light barrier in its entire breadth when Status Display "1" is shown and may not touch the housing physically.

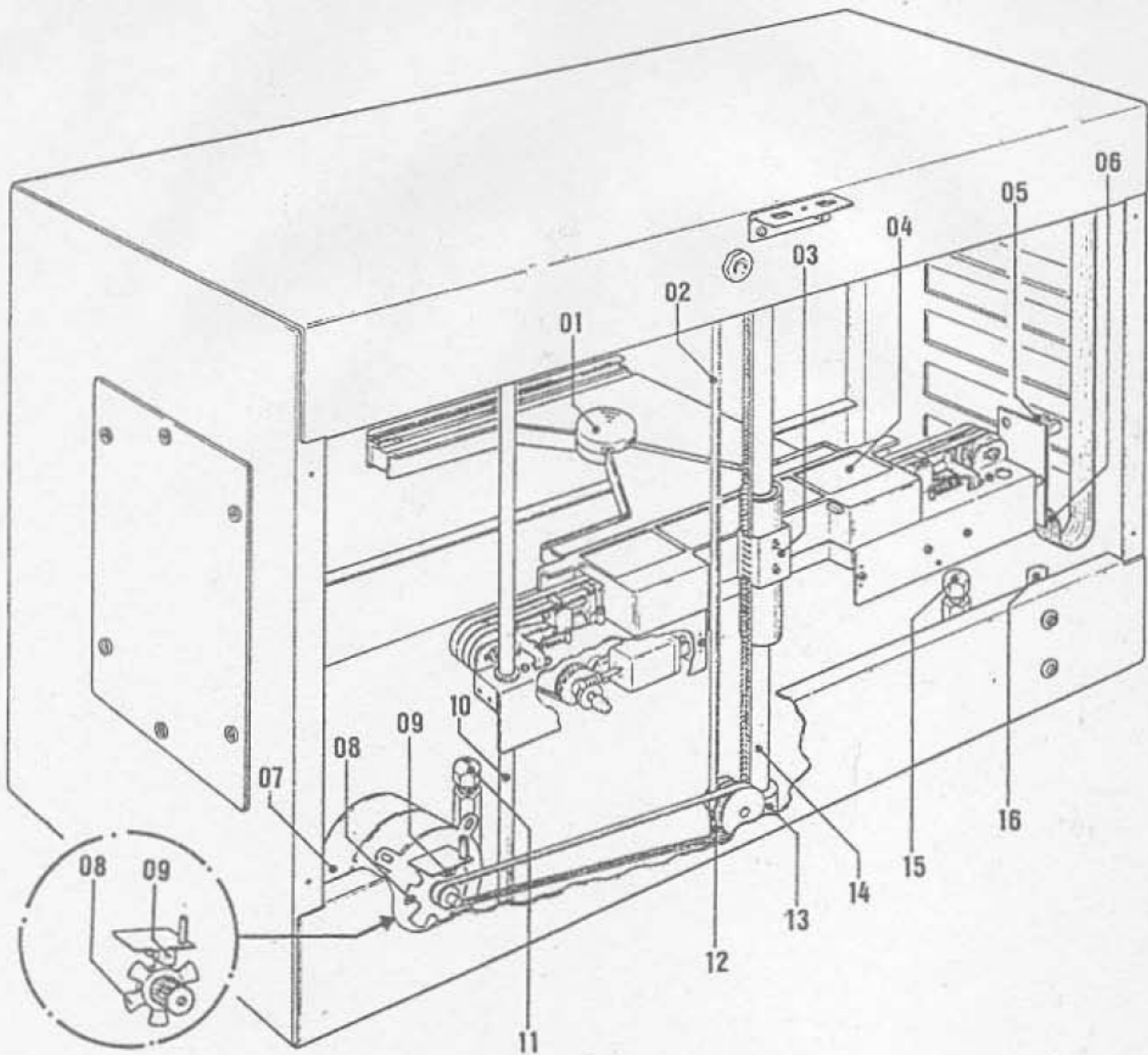

CD CHANGER, COMPL.

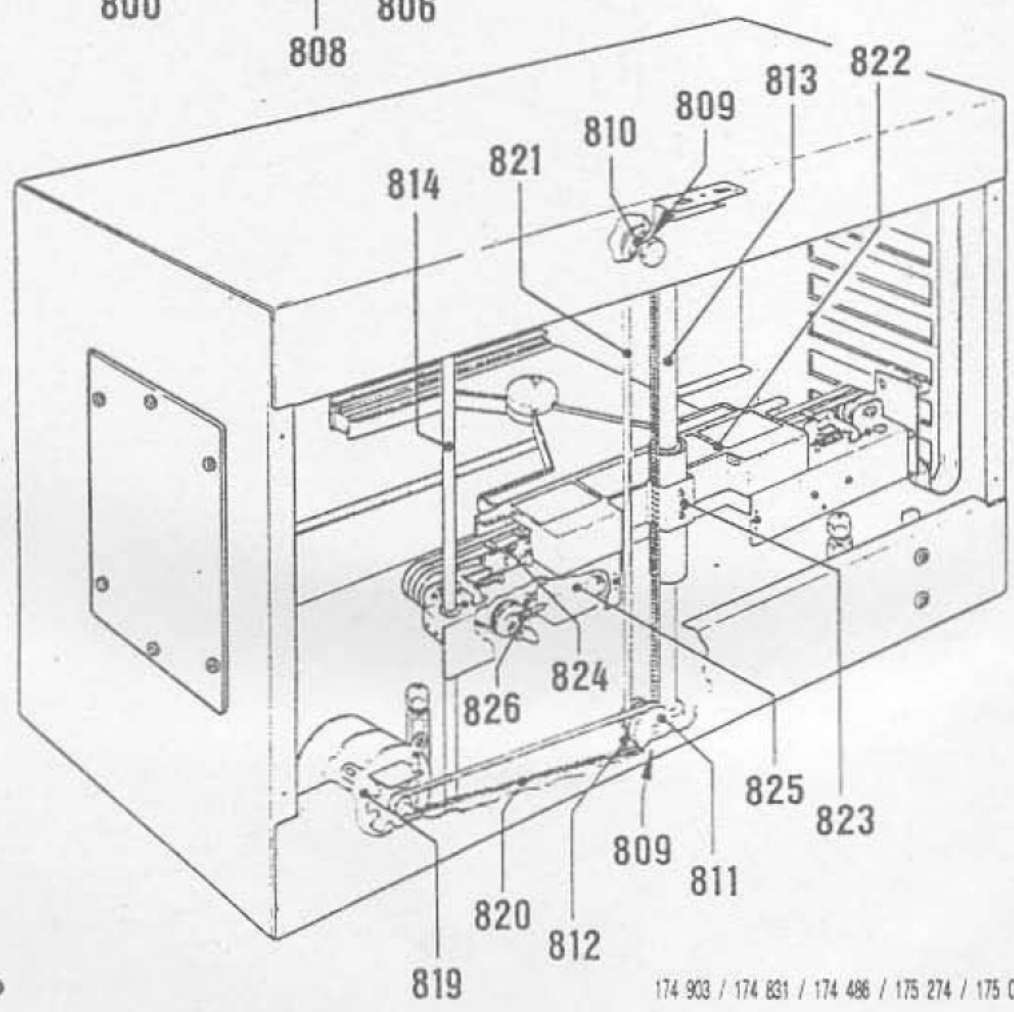
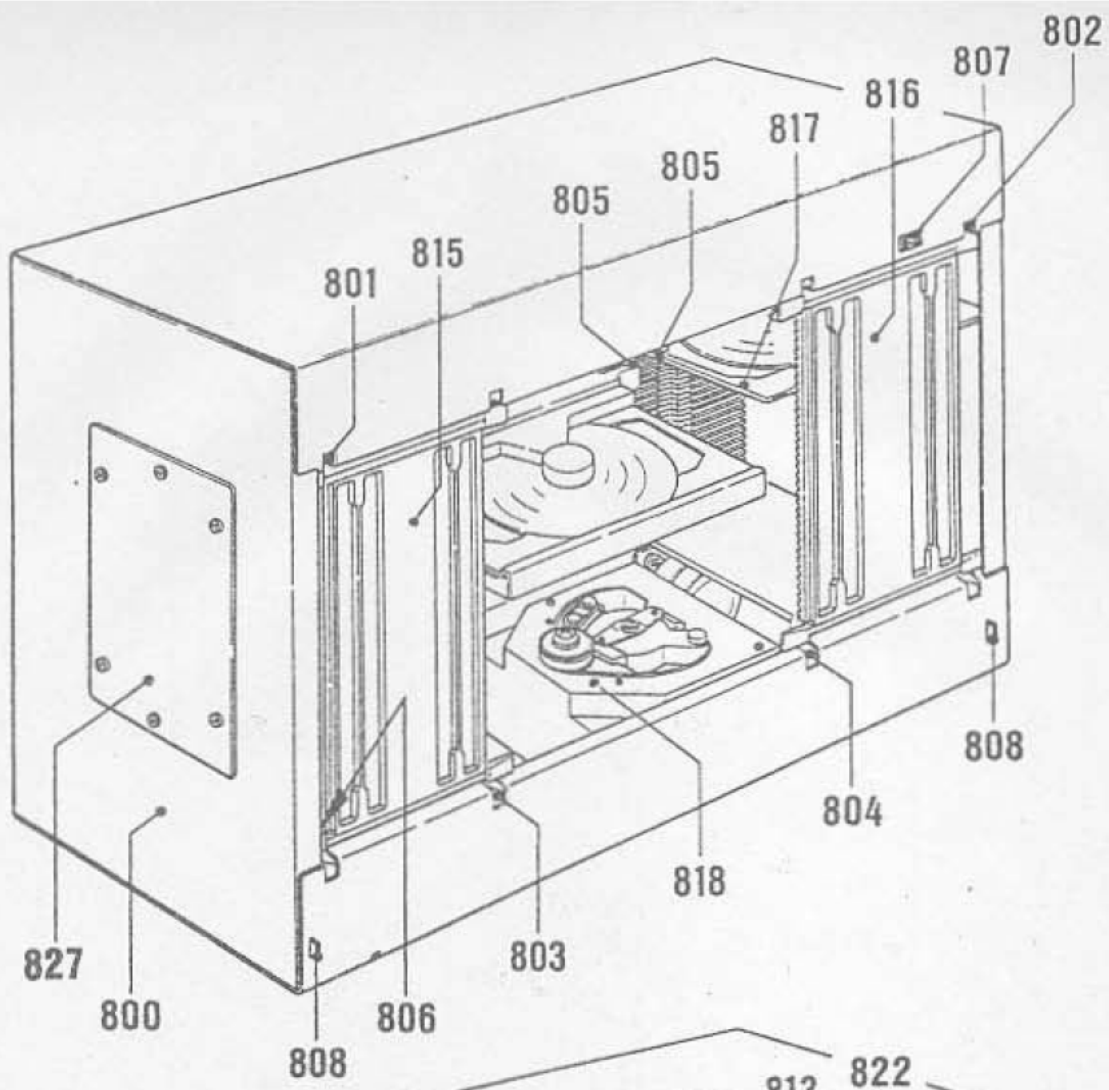

810

174 903 / 174 831 / 174 486 / 175 274 / 175 040 / 176 046

SPARE PARTS LIST

POS.	PART-No.	DESCRIPTION	DATA	QTY
	173 470	<u>CD-CHANGER 100, STANDARD</u>	without design parts without magazines	1
	175 980	CD-CHANGER 100, STANDARD by THE PERFORMER GRAND		1
801	174 296	CLOSING LEDGE, left upper		1
802	174 297	CLOSING LEDGE, right upper		1
803	174 294	CLOSING LEDGE, left lower		1
804	174 295	CLOSING LEDGE, right lower		1
805	173 485	CONTROL KNOB		2
806	206 655	CONNECTION AXLE		2
807	222 531	MICRO SWITCH f. CONNec. BLOCK	E63-10K	1
808	174 293	FLAT SPRING for VIEW GLASS		2
809	173 538	SCREW SLEEVE, ASSY		2
810	173 522	STEP WHEEL, MOUNTED		1
811	173 521	WASHER 48		1
812	173 526	BOARD WASHER		1
813	173 558	AXLE		1
814	173 559	GUIDE AXLE		1
	174 265	BRIDGE		1
	173 635	LIGHTING, ASSY		1
815	173 491	MAGAZINE LEFT, MOUNTED (without CASSETTE)		1
	209 737	NUMBER STRIP, 01 - 50		2
816	173 499	MAGAZINE RIGHT, MOUNTED (without CASSETTE)		1
	209 779	NUMBER STRIP, 51 - 100		2
817	174 536	CASSETTE CD 120	only 10 piece	2
	212 425	TRANSPORT GUIDE for CASSETTE		2
818	173 551	PLAY BACK UNIT, ASSY	with CD-PLAYER	1
819	173 518	STEP MOTOR, ASSY		1
820	206 644	BELT	MXL 195	1
821	206 643	BELT	MXL	1
822	173 607	LIFT, ASSY		1
	206 629	RUBBER RING		1
	209 776	LABEL	NSM 100 CD	1
	174 220	DECOR COVER		1
823	173 614	BELT LOCK		1
824	173 581	LIFT AXLE		1
825	173 606	MOTOR, ASSY		2
826	173 630	GEAR, MOUNTED		2
827	212 548	TRIMPLATE, PRINTED		2
	173 552	CB-CASSETT-CONTROL, ASSY		1
	173 563	CB-STEPPER, ASSY		1
	173 507	CB-DECODER BOARD, ASSY		1
	173 665	CB-PICK UP DRIVER, ASSY		1
	173 510	CB-LIFT ADAPTER, ASSY		1
	173 557	CB-MOTOR-CONTROL, ASSY		2
	173 508	CB-CHANGER ADAPTER, ASSY		1

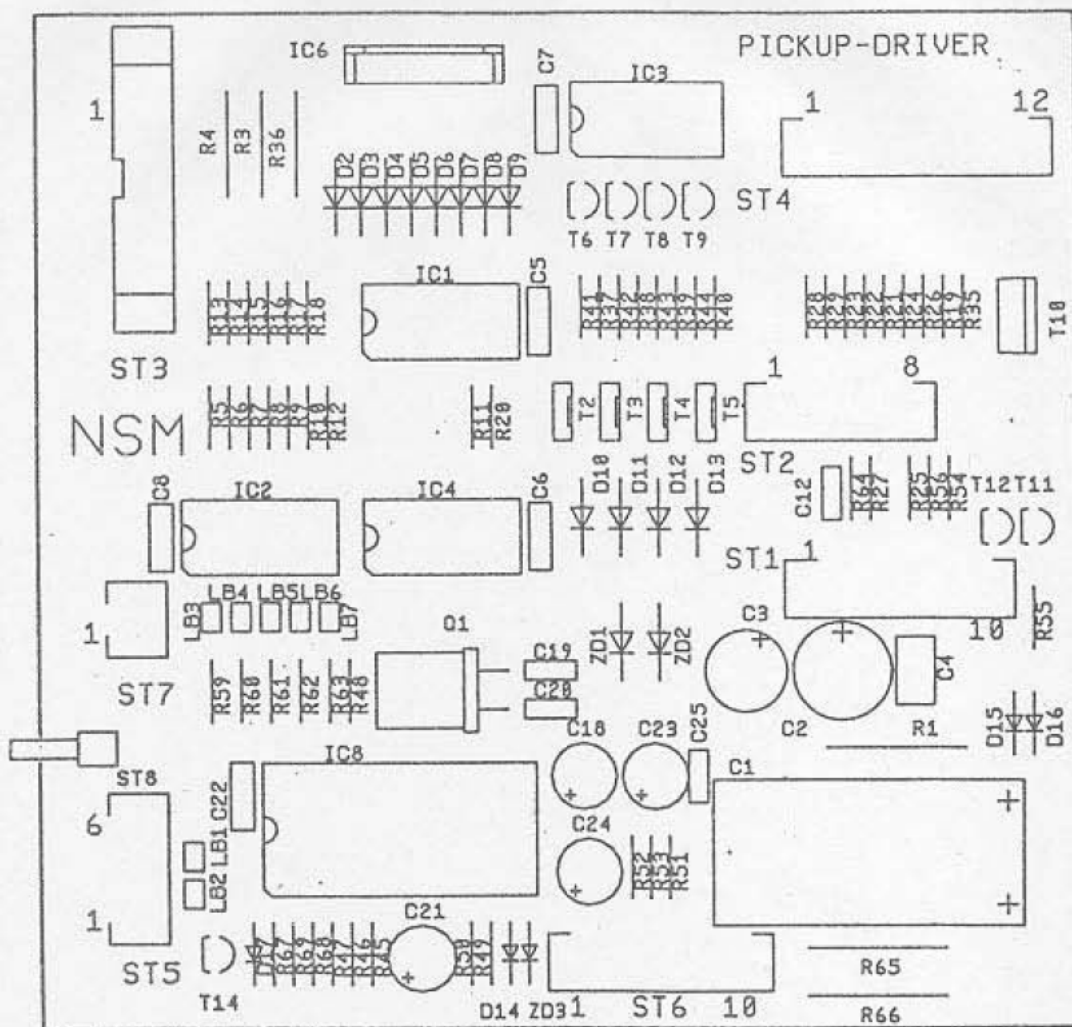

SPARE PARTS LIST

POS.	PART-No.	DESCRIPTION	DATA	QTY
	173 665	<u>CB-PICK UP DRIVER, ASSY</u>		1
ST 08	225 392	PIN PLUG	2 prongs 90°	1
ST 03	225 912	PIN PLUG	14 prongs	1
ST 07	225 650	PIN PANEL	2 prongs	1
ST 05	225 850	PIN PANEL	5 prongs	1
ST 02	225 653	PIN PANEL	8 prongs	1
ST 01	225 654	PIN PANEL	10 prongs	1
ST 04	225 655	PIN PANEL	12 prongs	1
Q 1	221 535	OSCILLATOR QUARTZ	4 MHZ	1
	222 447	IC-SOCKET	28 prongs	1
IC 8	231 409	IC-MICROCOMPUTER	MAB 8441	1
IC 5	231 303	IC-LINEAR	L 298	1
IC 3, 4	221 771	IC-CMOS	HEF 4094 B	2
IC 1, 2	221 763	IC-CMOS	HEF 4021 B	2
D14-16, 17	221 114	SI-DIODE	1 N 4148	4
D 2-13	221 822	SI-DIODE	BA 157	12
D 18, 19	221 115	SI-DIODE	1 N 4004	2
ZD 1, 2	231 326	ZENER-DIODE	ZY 24	2
T 11, 14	221 283	SI-TRANSISTOR	BC 212 B	2
T 6-9, 12	221 757	SI-TRANSISTOR	BC 547 B	5
T 2-5	221 777	SI-TRANSISTOR	BD 679	4
T 10	231 150	SI-TRANSISTOR	TIP 130	1
C 19, 20	220 266	CER.-CAPACITOR	27 pF	2
C 12	220 342	CER.-CAPACITOR	100 pF	1
C 5-8, 22	220 334	MKT-CAPACITOR	0,1 µF 63 V	5
C 4	220 332	MKT-CAPACITOR	0,33 µF 63 V	1
C 21	220 249	LYTIC	1 µF 63 V	1
C 18	220 389	LYTIC	47 µF 10 V	1
C 3	220 160	LYTIC	100 µF 10 V	1
C 2	220 391	LYTIC	220 µF 25 V	1
C 1	220 165	LYTIC	470 µF 40 V	1
R 64	221 606	RESISTOR	47 Ω ½ W	1
R 25, 54	221 600	RESISTOR	100 Ω ½ W	2
R 35	221 632	RESISTOR	160 Ω ½ W	1
R 37-40	221 614	RESISTOR	330 Ω ½ W	4
R 56, 67	221 099	RESISTOR	470 Ω ½ W	2
R 45, 49	221 029	RESISTOR	1 kΩ ½ W	2
R 27-29	221 033	RESISTOR	3,3 kΩ ½ W	3
R 46, 47	221 034	RESISTOR	4,7 kΩ ½ W	2
R 26, 41-44,				>
68, 69	221 035	RESISTOR	10 kΩ ½ W	7
R 5-12	221 603	RESISTOR	12 kΩ ½ W	8
R 13-20, 55	221 036	RESISTOR	15 kΩ ½ W	9
R 21-23,				>
59-63	221 604	RESISTOR	22 kΩ ½ W	8
R 24	221 048	RESISTOR	100 kΩ ½ W	1
R 48	221 009	RESISTOR	1 MΩ ½ W	1
P 3	221 392	RESISTOR	390 Ω ½ W	1
P1, 36, 65	221 692	WIRE WOUND RESISTOR	1 Ω 1 W	3
R 66	231 418	WIRE WOUND RESISTOR	2,7 Ω 1 W	1

SPARE PARTS LIST

POS.	PART-No.	DESCRIPTION	DATA	QTY
	173 508	<u>CB-CHANGER ADAPTER, ASSY</u>		1
ST 3	225 418	PIN PLUG	4 prongs	1
ST 2	225 412	PIN PLUG	4 prongs 90°	1
ST 12	225 660	PIN PANEL	2 prongs 90°	1
ST 1	225 661	PIN PANEL	4 prongs 90°	1
ST 9	225 652	PIN PANEL	6 prongs	1
ST 10	225 662	PIN PANEL	6 prongs 90°	1
ST 7, 11	225 653	PIN PANEL	8 prongs	2
ST 6	225 663	PIN PANEL	8 prongs 90°	1
ST 5	225 654	PIN PANEL	10 prongs	1
ST 4	225 664	PIN PANEL	10 prongs 90°	1
ST 8	225 655	PIN PANEL	12 prongs	1

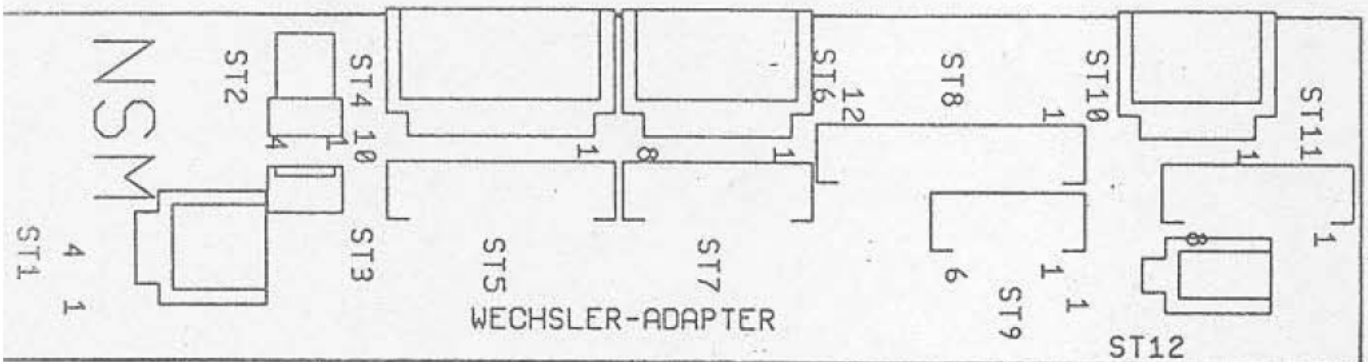

SPARE PARTS LIST

POS.	PART-No.	DESCRIPTION	DATA	QTY
	173 510	<u>CB-LIFT ADAPTER, ASSY</u>		1
ST 2	225 892	PLUG	14 prongs	1
ST 1	222 445	IC-SOCKET	16 prongs	1
OPEND	231 322	OPTO-COUPLER	LTH-301	1

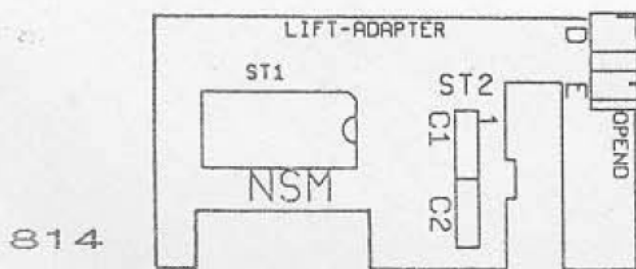

814

174 903 / 174 831 / 174 486 / 175 274 / 175 040 / 176 045

SPARE PARTS LIST

POS.	PART-No.	DESCRIPTION	DATA	QTY
	173 563	<u>CB-STEPPER, ASSY</u>		1
	231 322	OPTO-COUPLER	LTH-301	1
	112 464	CABLE HARNESS	4 prongs	1
	173 557	<u>CB-MOTORCONTROL, ASSY</u>		1
	231 322	OPTO-COUPLER	LTH-301	1

SPARE PARTS LIST

POS.	PART-No.	DESCRIPTION	DATA	QTY
	173 636	CABLE HARNESS: LIFT		1
	173 639	CABLE HARNESS: PICK UP - CABLE I		1
	173 641	CABLE HARNESS: PICK UP - CABLE II		1
	173 644	CABLE HARNESS: TRAILING CABLE		1
	151 645	CABLE HARNESS: DECODER CABLE I		1
	173 646	CABLE HARNESS: DECODER CABLE II		1
	173 647	CABLE HARNESS: DRIVER CABLE I		1
	173 648	CABLE HARNESS: DRIVER CABLE II		1
	173 649	CABLE HARNESS: DRIVER CABLE III		1
	173 740	CABLE HARNESS: NF - CABLE		1
	174 185	CABLE HARNESS: SWITCH		1

OPTO END POSITION
 OPTO GREIFER LINKS
 OPTO GRASP LEFT
 OPTO GREIFER RECHTS
 OPTO GRASP RIGHT
 OPTO PICK UP MITTE
 OPTO PICK UP CENTER
 OPTO STEPPER CONTROL
 MOTOR GREIFER LINKS
 MOTOR GRASP LEFT
 MOTOR GREIFER RECHTS
 MOTOR GRASP RIGHT

HI
 V

LTH 301

rot red
 schwarz black

NF

DECODER BOARD

Beleuchtung
 ILLUMINATION

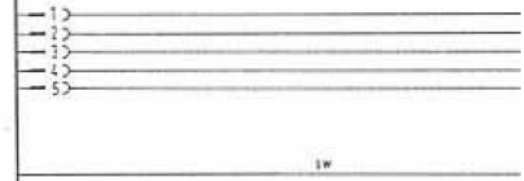
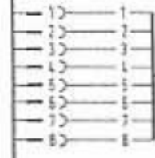
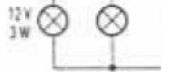

rechts
RIGHT

MOTOR CONTROL
 OP GRR

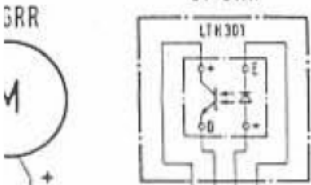

MOTOR CONTROL
 OP GRL

Motor links
 MOTOR LEFT
 MO GRL

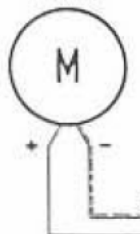
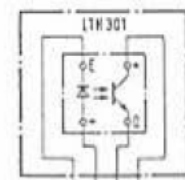

CD - PLAYER

CASSET CONTROL
 OP PUM

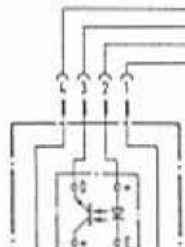

/ 174 830 / 174 485 / 175 275 / 175 039
 / 174 831 / 174 486 / 175 274 / 175 040
 / 175 594 / 175 599 / 176 043 / 175 593

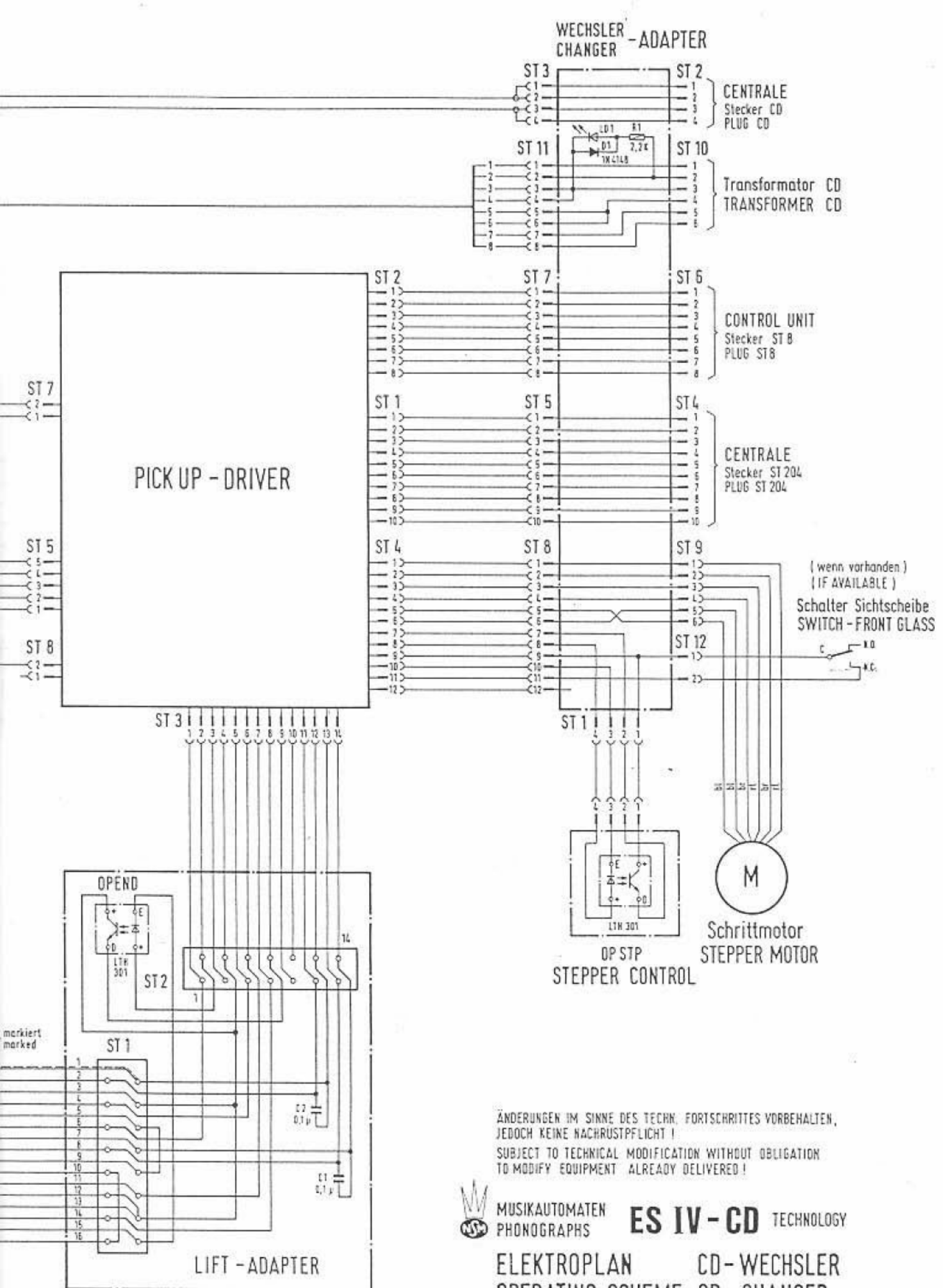

ÄNDERUNGEN IM SINNE DES TECHN. FORTSCHRITTES VORBEHALTEN,
 JEDOCH KEINE NACHRÜSTPFLICHT!
 SUBJECT TO TECHNICAL MODIFICATION WITHOUT OBLIGATION
 TO MODIFY EQUIPMENT ALREADY DELIVERED!



MUSIKAUTOMATEN
 PHONOGRAPHS

ES IV - CD TECHNOLOGY

ELEKTROPLAN CD - WECHSLER
OPERATING SCHEME CD - CHANGER

Dot. 06.02.91	Gez. Braun	Bechr. <i>leu</i>	Gepr. <i>Mann</i>
---------------	------------	-------------------	-------------------

UNIT DESCRIPTION

CENTRAL UNIT

FOR NSM-PHONOGRAPHS

ES IV-CD TECHNOLOGY

to
Technical Information, Assy

174 903	SILVER CITY
174 831	SILVER SKY
174 486	FASCINATION
175 274	SOUNDMASTER
175 040	FIREBIRD/COUNTRY
176 046	THE PERFORMER "GRAND"

NSM
Aktiengesellschaft
Saarlandstraße 240
6530 Bingen am Rhein

6

Page 601-611/621

INDEX

- 1 FUNCTION
 - 1.1 Power Supply
 - 1.2 Amplifier
 - 1.3 Signal path
 - 1.4 Adjustment of controls
 - 1.5 MIC socket, microphone connection
 - 1.6 TB socket
 - 1.6.1 Tape recorder connection
 - 1.6.2 Connection of auxiliary amplifier

- 2 Adjustment instructions for trimmer of central unit and output stage

- 3 Repair aid
 - 3.1 Output stage
 - 3.2 Control of volume and muting
 - 3.3 Tracing sound signal

1 FUNCTION

The power supply, fan controls, stereo amplifier with inputs for microphone, CD and tape are all integrated on one circuit board.

The output stages and the fan are connected to the central unit via ST 209, ST 210, ST 211. The music power per channel is 200 watts when matched to a loudspeaker impedance of 2 ohms.

1.1 Power Supply

The power transformer supplies 22 V, 2 x 11,5 V and 2 x 43 V from three separate secondary coils. The supply voltage for the output stages is supplied with 2 x 43 V by a two-way rectifier (D 206) and the center tap of the transformer.

The supply voltage for the voltage regulator VR 201, +5 V is supplied with 2 x 11,5 V by a two-way rectifier (D 201/202) and the center tap on the transformer. The low voltage recognition is accomplished by D 204 and D 205. Fusing is accomplished with Si 201 and Si 202. Fusing for the output stage is accomplished with Si 204 and Si 205.

The non-controlled voltage +14 V for the display and key illumination is being picked up at capacitor C 201.

The control voltage of +15 Va, for the pickup driver, coin mechanism, control unit, remote control, luminous effects as well as the supply voltage for the preamplifier of +15 Vb, are supplied by the 22 V transformer coil and rectified by D 207 through 210 and VR 203. Fusing is accomplished by Si 203.

The LED's indicate the following supply voltages at the same intensity:

LED 201 = + 5 V

LED 202 = +60 V

LED 203 = +15 V a

LED 204 = +15 V b

The TRIAC TIC 200 controls the output stage fan depending upon the operational state of the amplifier (REJECT); i.e. the fan only runs when the amplifier is not muted.

1.2 Amplifier

The stereo amplifier is equipped with two tone control IC's, one AF switch IC, 50 diodes and 17 transistors.

The output stage is designed without induction coils or transformers and is therefore ironless.

At full volume level the music power is 200 watts per channel.

1.3 Signal path

The input signal MIC goes to microphone amplifier T 230 and background mixer of TA, TR 231 to Pins 4 and 8 of IC 230. The TB input is connected to Pins 3 and 7. The CD input is connected to Pin 2 and Pin 6.

In the play mode the signal goes from Pin 2 to Pin 15 respectively through Pin 6 and Pin 9.

When the microphone switch is actuated, the signal goes from Pin 4 to Pin 15 or from Pin 8 to Pin 9.

In the tape mode (TB/Pin 6 to ground) the signal goes from Pin 3 to Pin 15 or Pin 7 to Pin 9 when the switch is actuated. In the MIC, CD or TB stage, muting is switched off regardless of the operating state of the phonograph. The stage "MIC" has priority switching.

From the AF switch (IC 230) the signal goes via an AVC (automatic volume control) T 250, T 251 at Pin 9 of the tone control IC 251 with associated bass booster. Treble control is accomplished with TR 252 and bass control with TR 253. The control voltage for the volume and muting is on Pin 5; approx. 2,5 V at full volume, approx. 0 V while muting.

The DC signal for the volume setting is supplied by the control unit. Signal Output Pins 3 and 6 of IC 251 are routed through a network to the driver stage for the output stage.

The parallel complementary power Darlington transistors T 151 through T 154 in the output stage allow a minimum loudspeaker impedance of 2 ohms. Quiescent current compensation and thermic stabilization is accomplished with T 150, the quiescent current setting with TR 250. The amplifier is equipped with three protective circuits against overload mismatching, thermic overload.

1.) T 155 acts as a threshold switch for the electronic fuse. When the emitter current of the output transistors exceeds a certain value, T 252 is switched through by T 155 switching on the muting and thereby limiting the current.

2.) The actuation of the electronic fuse at collector T 252 is controlled by the control unit.

When its fuse is tripped a number of times within a certain period, the volume is reduced automatically by one step each time until the electronic fuse is no longer activated.

3.) The thermal switch on the heat sink switches off the power supply to the output stage when the heat sink temperature reaches approx. 90 C (cooling malfunctioning). LED 150 is dark. The switch-on point (following cooling down) is approx. 60 C (switch-on hysteresis).

The terminating impedance at the loudspeaker output should not be less than 2 ohms. In the case of mismatching (less than 2 ohms), or short-circuit in the loudspeaker cable, the limiting circuit is actuated.

The result is distorted sound reproduction or reduction of the volume. After elimination of the mismatch the amplifier is ready for operation and the volume can be readjusted.

The volume difference between the two channels is compensated at the factory by setting the leveling potentiometer TR 254.

1.4 Adjustment of Controls

TR 230 = microphone volume
TR 231 = music fade-in for microphone mode
TR 252 = treble control
TR 253 = bass control

TR 230 for setting the microphone amplifier:

This adjustment is dependent upon the position of the phonograph in relation to the microphone and required microphone volume.

In case of feedback while paging, the control must be turned counterclockwise or the microphone be positioned in another direction to the speakers.

TR 231 for music fade-in in microphone mode:

There the desired music volume level during paging can be controlled.

TR 252 R and TR 252 L, treble controls, are to be set according to the locations.

The maximum position is suggested in acoustically balanced rooms only.

TR 253 R and TR 253 L, bass controls, must also be set according to the locations and the desired bass reproduction.

1.5 MIC socket, Microphone Connection

A dynamic microphone with an impedance of 200 ohms - 600 ohms with switch for relay control can be used.

NSM option accessories:

Microphone	Order No.	224 223	
Connection cable	Order No.	171 880	(10 m long)

1.6 TB Socket

1.6.1 Tape Recorder Connection

The TB socket allows the music from the phonograph to be recorded on a tape recorder as well as music from a tape recorder to be played by the phonograph.

The AF signal (analog signal) for recording with a tape recorder is on Contacts 1 and 4 and can be connected directly with a stereo diode cable; Contacts 2, 7 and 8 (8 is ground).

1.6.2 Connection of Auxiliary Amplifier

An auxiliary amplifier can be connected to the TB socket. The AF signal can be fed directly from the TB socket (Contacts 1 and 4) to be input of the amplifier with a stereo diode cable.

The input sensitivity of the external amplifier should be 200 mV at a minimum input impedance of 47 KOhms.

Note: A stereo diode cable with a 5-pin plug is suitable for the above connections. In this plug Pin 1 must be connected to Pin 1; 3 to 3; etc.

The stereo recording cable is **not suitable** because in such cables Pin 1 is connected to 3 and 4 to 5 (crossed).

2 Adjustment Instructions for Trimmer of Central Unit and Output Stage

TR 150 for quiescent current adjustment of the output stage: The quiescent current must be set to 40 mA +5 mA. After replacement of the output transistor T 151 through T 154 a correction may be required.

Important! Muting is to be switched off for measuring and setting. The lift will be put in play position, the volume control is set at 0 and Si 150 or the thermal switch are replaced by an ampere meter.

TR 201 and TR 202 for adjustment of volume control voltage:

Maximum volume for regularly selected titles in program step P 28 must be programmed to "31" (full volume).

Take measurements at test points TP-L and TP-R to ground; nominal value = 2,6 V (factory setting),

The internal resistance of the measuring instrument must be greater than 1 MOhm!

After replacement of IC 251 a correction may be required.

TR 254 R and TR 254 L, level controls for adjustment of the total amplification: Set at factory to correspond to the output voltage of the CD player.

Muting must be switched off. Volume, treble and bass set to maximum.

The output voltage on the loudspeaker connection with a load of 4 ohms is approx. 10 V = 25 W power per channel, with the AVC at full level. At minimum impedance of 2 ohms the RMS output corresponds to 100 W RMS or 200 W music power at disc playing.

3 Repair Aid

Amplifier integrated in central unit ES IV

Malfunction: No sound, no output power:

It is assumed that LD 201 to LD 204 glow with the same intensity and that the power supply is therefore O.K., the CD is on the CD player being played, and normal volume was set in program step P28 to "31".

3.1 Output Stage

LD 150 on the output stage circuit board is dark. Malfunction probably located in the output stage; check SI 150 and replace if required. If the fuse blows again, the output transistors are defective.

Remove output stage unit, pull out cover plates on the bottom. Check for short-circuit on transistors T 151/T 152 T 153/T 154 with ohmmeter. Since the transistors are connected in parallel, it is only possible to test them in pairs.

For individual testing one transistor must be unsoldered from the defective pair. After replacement of the defective transistors the quiescent current must be readjusted with TR 150 according to the adjustment instructions.

3.2 Control of Volume and Muting

In the play mode approx. 2,6 V must be measured on Pin 5 of IC 251 (for full volume).

If the voltage is near 0 V, T 252 or the control "volume L and R" from the computer must be checked (reject line).

3.3 Tracing Sound Signal

Trace the sound signal arriving at CD plug according to the table.

The point where the signal is missing is probably the cause of the malfunction.

AF Signal Point	Cause of Malfunction When Signal Missing
C 237, C 238	IC 230
IC 251, L/R Pin 9	T 250 / T 251 (AVC)
R 269, L/R (2,6 V am IC 251/ Pin 5)	IC 251 L/R
T 255 L/R (collector)	T 253 L/R

If the signal is there up to T 255, but no output signal arrives at the output stage, plug connectors ST 210/211 as well as the output stage have to be checked.

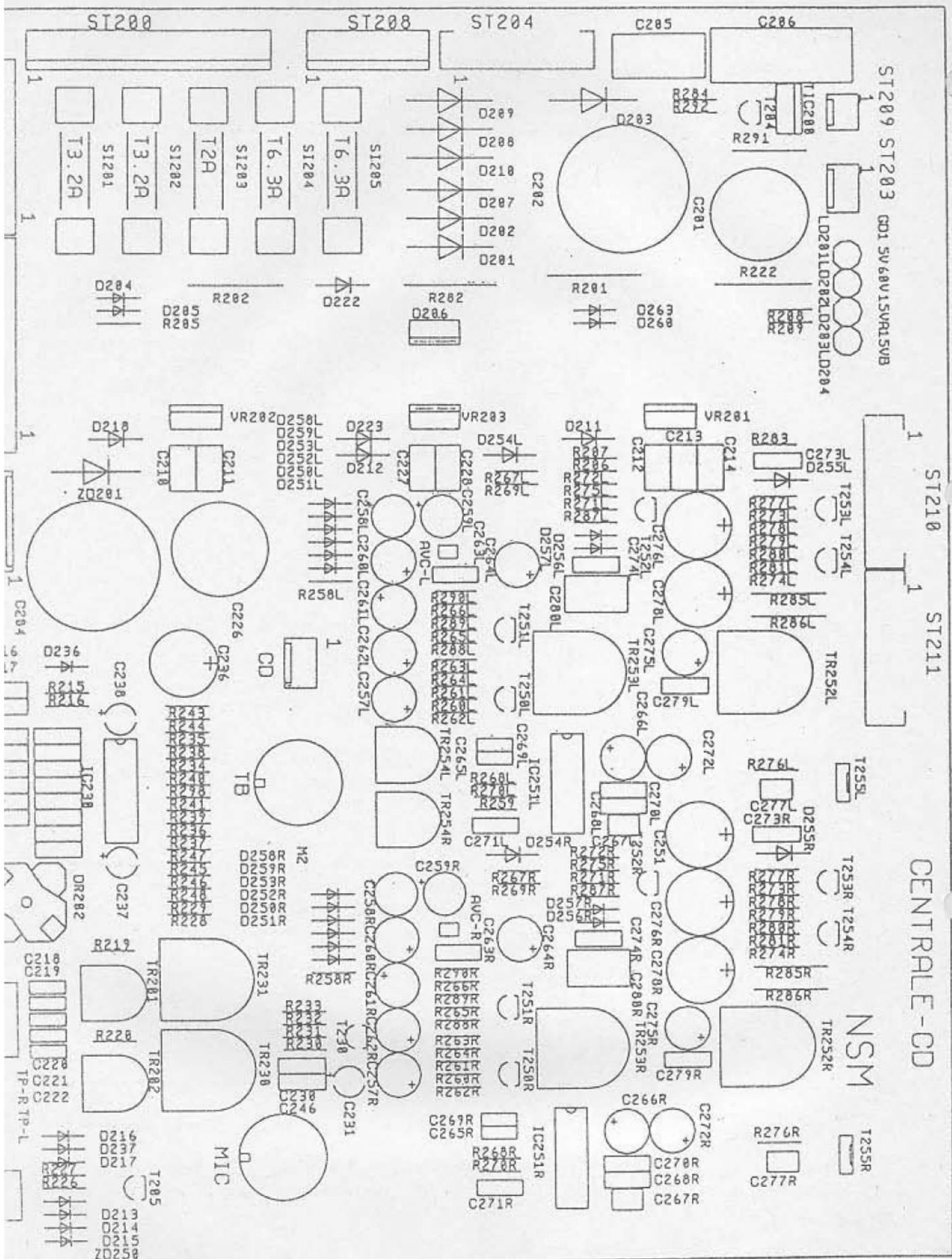

CENTRALE-CD

NSM

ST209 ST203 CD1 5V60V15VH15VB

ST210 ST211

SPARE PARTS LIST

POS.	PART-No.	DESCRIPTION	DATA	QTY
	173 666	<u>CENTRAL UNIT, ASSY</u>	50/60 Hz	
SI 203	225 538	FUSE	by 50 Hz T 2,5 A	1
SI 201, 202	225 029	FUSE	T 3,15 A	2
SI 204, 205	225 374	FUSE	T 6,3 A	2
SI 203	225 220	FUSE	by 60 Hz T 2,0 A	1
SI 201, 202	225 225	FUSE	T 3,2 A	2
SI 204, 205	225 218	FUSE	T 6,25 A	2
	173 730	COOLING PLATE		1
SI 201-205	225 689	FUSE HOLDER		10
	173 698	PROFILE, ASSY		2
	173 944	SHIELDING COVER		1
MJC	225 244	SOCKET	S 5 prongs	1
TB	225 749	SOCKET	Mab 8 SV	1
ST 209	225 439	PIN PLUG	RM 2,5 3 prongs	1
ST 203,				>
206, CD	225 418	PIN PLUG	RM 2,5 4 prongs	3
ST 205	225 443	PIN PLUG	RM 2,5 6 prongs	1
ST 208	225 804	PIN PLUG	RM 3,96 6 prongs	1
ST 207	225 444	PIN PLUG	RM 2,5 8 prongs	1
ST 200	225 807	PIN PLUG	RM 3,96 12 prongs	1
ST 204,				>
210, 211	225 654	PIN PANEL	RM 2,5 10 prongs	3
ST 202	225 714	PIN PANEL	RM 2,5 12 prongs	1
ST 201	225 656	PIN PANEL	RM 2,5 15 prongs	1
VR 201	221 572	IC-VOLTAGE	+ 5 V 1 A	1
VR 202, 203	221 476	IC-VOLTAGE	+15 V 1,5 A	2
IC 230	231 236	IC-LINEAR	TDA 1029	1
IC 251 RL	231 089	IC-LINEAR	TDA 4290-2	2
D 201-203,				>
207-120	221 463	SI-DIODE	BY 251	7
D 211, 212,				>
218, 222,				>
223, 254				>
RL, 255 RL	221 115	SI-DIODE	1 N 4004	9
D 204, 205,				>
213-217,				>
236, 237,				>
251-253 RL,				>
256 RL	221 114	SI-DIODE	1 N 4148	27
D 206	231 202	SI-DUO-DIODE	BYV 32/100	1
ZD 201	221 821	TRANSZORB-DIODE	TVS 515	1
LD 201-204	221 466	LIGHT EMITTING DIODE	LR 3160-F	4
TIC 200	231 028	TRIAC	TIC 206 D	1

SPARE PARTS LIST

POS.	PART-No.	DESCRIPTION	DATA	QTY
T 204, 253				>
RL	221 459	SI-TRANSISTOR	PNP BC 556 B	3
T 230, 250				>
RL, 251 RL	221 249	SI-TRANSISTOR	NPN BC 550 B	5
T 255 RL	221 488	SI-TRANSISTOR	NPN BD 139-10	2
T 252 RL,				>
205	221 332	SI-TRANSISTOR	NPN BC 337-16	3
C 263 RL	220 342	CER.-CAPACITOR	100 pF	2
C 277 RL	220 185	CER.-CAPACITOR	270 pF	2
C 257 RL	220 274	CER.-CAPACITOR	330 pF	2
C 241, 242	220 241	CER.-CAPACITOR	560 pF	2
C 245	220 263	CER.-CAPACITOR	1 nF	1
C 243, 244	220 400	KT-CAPACITOR	1,5 nF	2
C 259 RL	220 401	KT-CAPACITOR	3,3 nF	2
C 218-222,				>
265 RL,				>
279 RL	220 435	KT-CAPACITOR	4,7 nF	9
C 268 RL	220 429	MKT-CAPACITOR	0,15 µF 100 V	2
C 270 RL	220 335	MKT-CAPACITOR	0,022 µF 63 V	2
C 216, 217,				>
230, 234,				>
235, 239,				>
240, 271 RL,				>
273 RL, 281,				>
282	220 334	MKT-CAPACITOR	0,1 µF 63 V	13
C 274 RL	220 333	MKT-CAPACITOR	0,22 µF 63 V	2
C 210-214,				>
227, 228,				>
280 RL	220 332	MKT-CAPACITOR	0,33 µF 63 V	9
C 205	220 336	MKT-CAPACITOR	2,2 µF 63 V	1
C 206	220 460	MKT-CAPACITOR	3,3 µF 63 V	1
C 258 RL,				>
259 RL	220 243	TAN-CAPACITOR	SF 100 µF 3 V	4
C 260 RL	220 249	LYTIC	1 µF 63 V	2
C 231, 237,				>
238, 257 RL,				>
262 RL, 264				>
RL	220 159	LYTIC	4,7 µF 63 V	9
C 261 RL,				>
266 RL, 275				>
RL	220 162	LYTIC	10 µF 63 V	6
C 272 RL	220 389	LYTIC	47 µF 10 V	2
C 276 RL,				>
278 RL	220 158	LYTIC	47 µF 40 V	4
C 236	220 160	LYTIC	100 µF 10 V	1
C 251	220 250	LYTIC	100 µF 25 V	1
C 226	220 289	LYTIC	1000 µF 40 V	1
C 201	220 283	LYTIC	2200 µF 25 V	1
C 202	220 286	LYTIC	4700 µF 25 V	1
C 204	220 287	LYTIC	4700 µF 40 V	1

SPARE PARTS LIST

POS.	PART-No.	DESCRIPTION	DATA	QTY
R 276 RL	221 095	RESISTOR	6,8 Ω	½ W 2
R 259, 279				>
RL, 287 RL	221 611	RESISTOR	10 Ω	½ W 5
R 206	221 620	RESISTOR	22 Ω	½ W 1
R 277 RL	221 096	RESISTOR	56 Ω	½ W 2
R 270 RL	221 600	RESISTOR	100 Ω	½ W 2
R 263 RL	221 635	RESISTOR	180 Ω	½ W 2
R 264 RL	221 614	RESISTOR	330 Ω	½ W 2
R 208	221 099	RESISTOR	470 Ω	½ W 1
R 267 RL	221 622	RESISTOR	820 Ω	½ W 2
R 205, 207, 269 RL, 288				>
RL	221 029	RESISTOR	1 KΩ	½ W 6
R 275 RL	221 030	RESISTOR	1,5 KΩ	½ W 2
R 209, 263	221 031	RESISTOR	2,2 KΩ	½ W 2
R 278 RL, 298	221 033	RESISTOR	3,3 KΩ	½ W 3
R 262 RL	221 172	RESISTOR	8,2 KΩ	½ W 2
R 266 RL, 226, 284, 289 RL, 292	221 035	RESISTOR	10 KΩ	½ W 7
R 219, 220	221 501	RESISTOR	18 KΩ	½ W 2
R 268 RL, 227	221 604	RESISTOR	22 KΩ	½ W 3
R 290 RL	221 037	RESISTOR	33 KΩ	½ W 2
R 230, 243- 248, 271 RL	221 038	RESISTOR	47 KΩ	½ W 9
R 274 RL	221 039	RESISTOR	56 KΩ	½ W 2
R 258 RL	221 629	RESISTOR	68 KΩ	½ W 2
R 261 RL	221 044	RESISTOR	82 KΩ	½ W 2
R 273 RL	221 048	RESISTOR	100 KΩ	½ W 2
R 272 RL	221 045	RESISTOR	150 KΩ	½ W 2
R 215, 216, 234-241	221 049	RESISTOR	470 KΩ	½ W 10
R 265 RL	221 981	RESISTOR	560 KΩ	½ W 2
R 260 RL	221 041	RESISTOR	820 KΩ	½ W 2
R 228, 229, 232, 233	221 009	RESISTOR	1 MΩ	½ W 4
R 231	221 982	RESISTOR	3,3 MΩ	½ W 1
R 285 RL	221 230	RESISTOR	470 Ω	½ W 2
R 291	221 183	RESISTOR	1 KΩ	½ W 1
R 286 RL	221 210	RESISTOR	1,5 KΩ	½ W 2
R 201, 202, 282	221 692	WIRE WOUND RESISTOR	1Ω	1 W 3
R 222	231 232	WIRE WOUND RESISTOR	6,8 KΩ	1 W 1
TR 252 RL, 253 RL	231 086	TRIMMER RESISTOR	10 KΩ	0,15 W 4
TR 230	231 233	TRIMMER RESISTOR	1 MΩ	0,15 W 1
TR 231	231 234	TRIMMER RESISTOR	2,5 MΩ	0,15 W 1
TR 252 RL, 253 RL, TR				>
230, TR 231	231 235	SHAFT	rot Nr. 5214	6
TR 201, 202	221 278	TRIMMER RESISTOR	10 KΩ	0,1 W 2
TR 254 RL	221 414	TRIMMER RESISTOR	100 KΩ	0,1 W 2

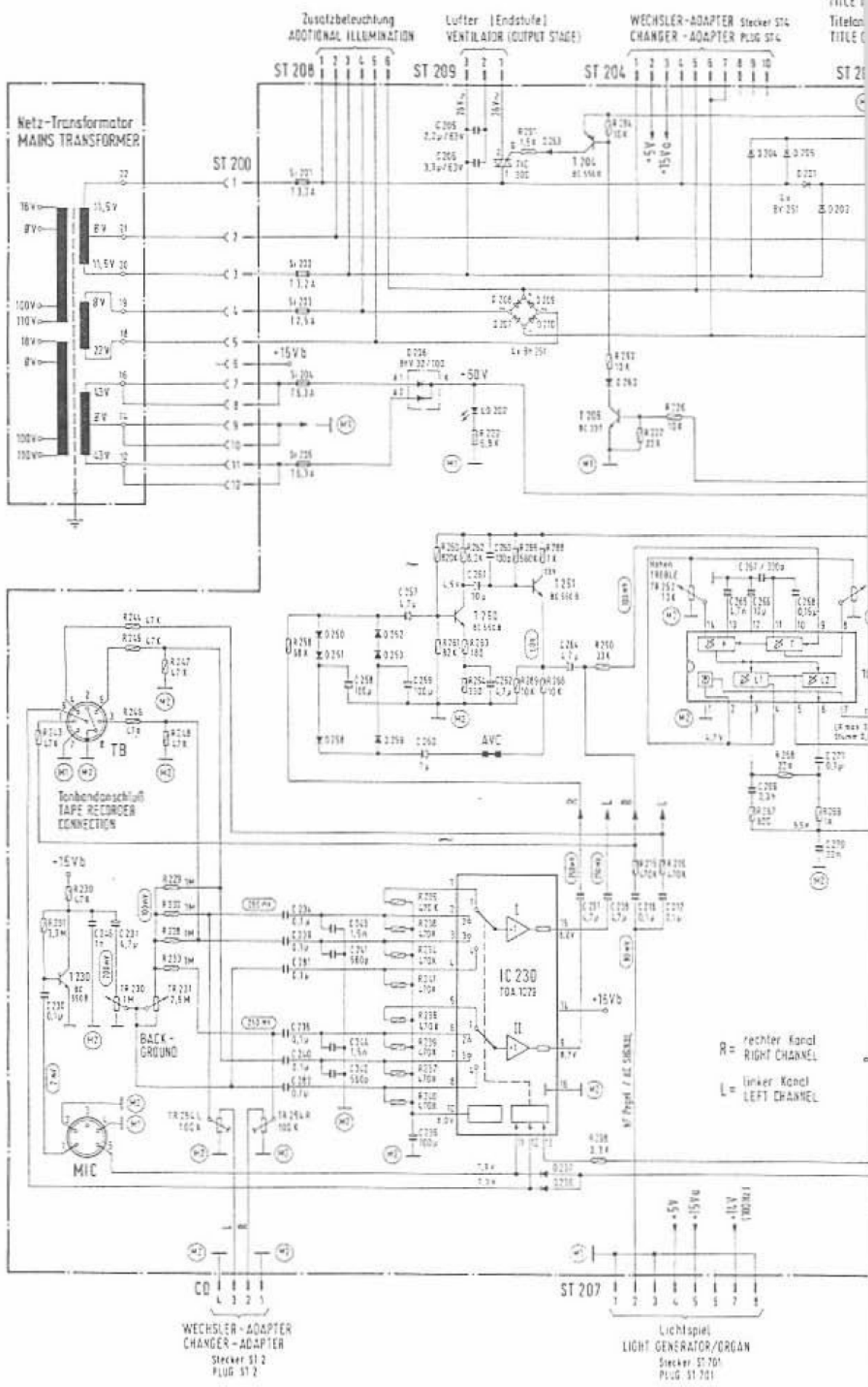

R = rechter Kanal
RIGHT CHANNEL
L = linker Kanal
LEFT CHANNEL

174 902 / 174 830 / 174 485 / 175 275 / 175 039 / 178 C45
174 903 / 174 551 / 174 486 / 175 274 / 175 040 / 178 C46

Wf-Regel: bei 1 kHz Lautstärke
Hörer und Bauteile max. mit 20°C
Stromspannung gemessen mit
AC 50/60Hz Voltmeter 01-100000

Stecker ST 1
 PLUG ST 1
 Programmier Stecker ST 601
 PROGRAM LID PLUG ST 601

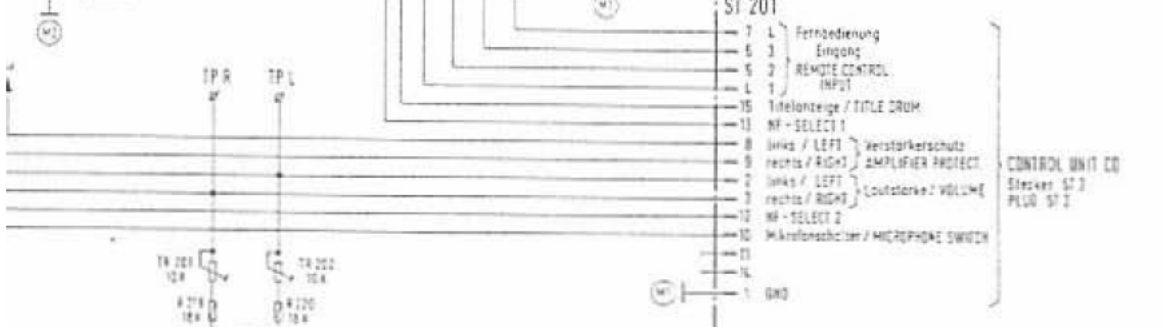
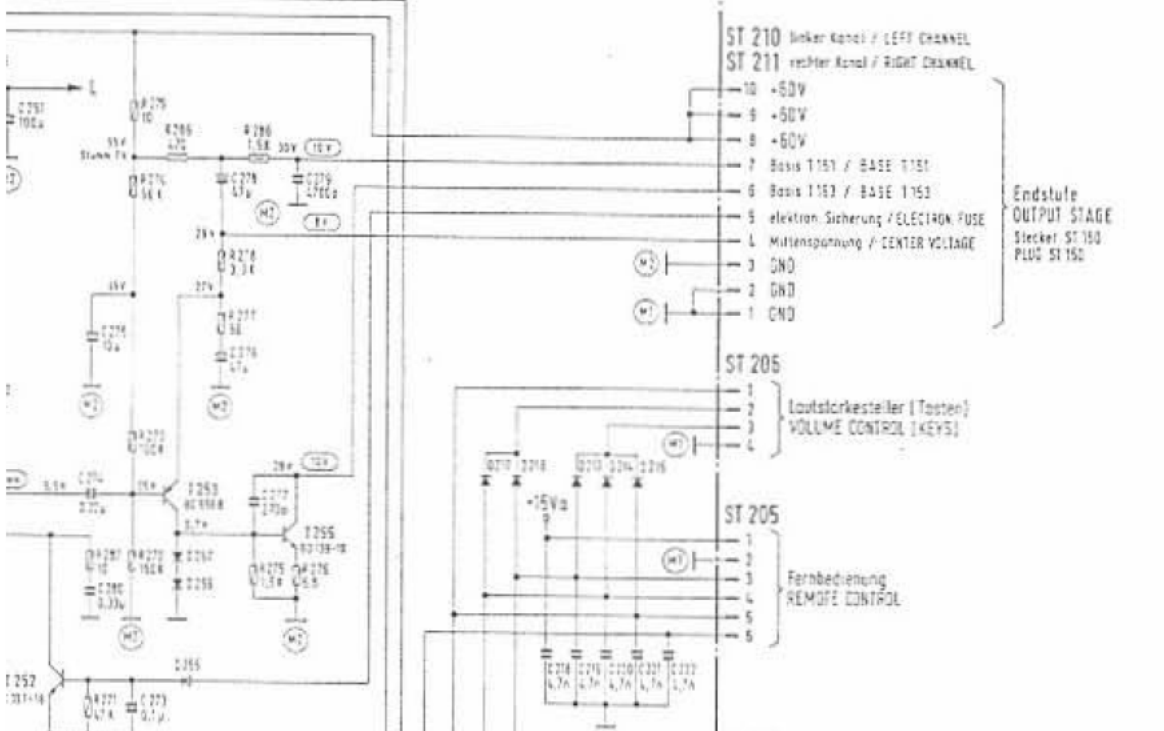
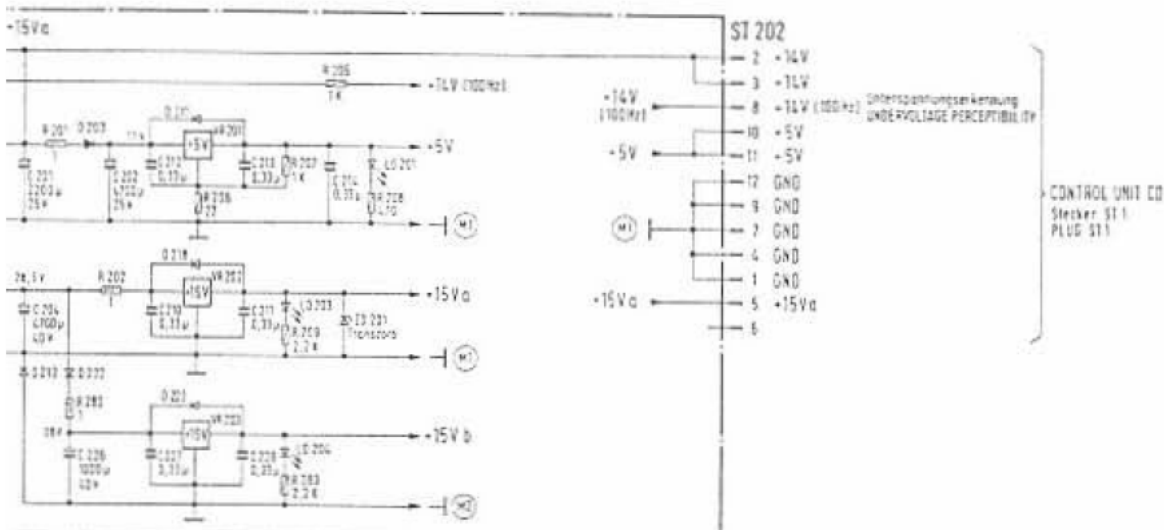

- von unten gesehen
 BOTTOM VIEW
- Drucklicht
 TOP VIEW
- Wahrscheinlich Voltmeter
 MZL
- 72 MAX. 1800.03 400
- 16 337-10 KANAL-ABSSELER
 - 50 135-10
 - VR 201
 - VR 202
 - VR 203
 - 50
 - 70 202
 - TR 201 10k
 - TR 202 10k
 - R 218 10k
 - R 219 10k
 - TR 203
 - TR 204

Sicherungen nur durch solche mit gleichen Werten ersetzen.
 REPLACE FUSES ONLY BY THOSE OF THE SAME VALUE.

ÄNDERUNGEN IM SINNE DES TECHN. FORTSCHRITTES VORBEHALTEN,
 JEDOCH KEINE NACHRÜSTPFLICHT!
 SUBJECT TO TECHNICAL MODIFICATION WITHOUT OBLIGATION
 TO MODIFY EQUIPMENT ALREADY DELIVERED!

MUSIKAUTOMATEN PHONOGRAPHS **ES IV-CD TECHNOLOGY**
 Schaltbild WIRING DIAGRAM **CENTRALE-CD**

UNIT DESCRIPTION

ELECTR. COIN- AND BILL ACCEPTOR FOR NSM-PHONOGRAPHS

ES IV-CD TECHNOLOGY

to
Technical Information, Assy

174 903	SILVER CITY
174 831	SILVER SKY
174 486	FASCINATION
175 274	SOUNDMASTER
175 040	FIRE BIRD/COUNTRY

NSM
Aktiengesellschaft
Saarlandstraße 240
6530 Bingen am Rhein

10

Page 1001-1006

INDEX

- 1 MECHANICAL COIN CHUTE
- 2 BILL VALIDATION - DOLLAR BILL ACCEPTOR
- 3 MARS ELECTRONIC COIN VALIDATOR
 - 3.1 Monetary Value Settings
 - 3.2 Price Tables
 - 3.3 Other Settings/Information

1 MECHANICAL COIN CHUTE

See also the circuit in the wiring diagram in the appendix of the "Technical Information".

The coins that come out of the "good" channels of the coin acceptor run through different optic barriers. The optic barriers are in the coin chute under the coin acceptor.

Two photo transistors, T III and T I as well as T IV and T II are illuminated by one IR diode each (LED I and LED II).

As long as a light barrier is not interrupted by a coin, all photo transistors, T I to T IV, are switched to logically "0". So all output lines.

1 = T IV,

2 = T III,

3 = T I,

4 = T II are at logically "0", i.e. their voltage level is 1,0 V.

If a coin passes through an optic beam, the respective photo transistor is darkened for that time. The output becomes log. "1" via the pull-up resistors in the control unit, i.e. their level is 10 V.

Since T I is also darkened, when T III is effected by a coin (T I is behind T III, both are illuminated by the same light diode), the output from T I over T V is kept at "0". This occurs via resistors R 72, R 70; they bring transistor T V in a satiated state when T III is open.

The same goes for T IV; it is kept at "0" by T VI when a coin falls through T II. The control for T VI occurs via R 73, R 69.

The addition button is switched in sequence to T IV so that Line 1 becomes log. "1" at service credit.

R 67 limits the current of the luminous diodes LED I and LED II.

The output signals of the four photo transistors are evaluated in the control unit whereby line.

1 = P 54,

2 = P 53,

3 = P 52,

4 = P 51 is assigned to the monetary value setting in the service program and is to be programmed according to the coin value; see "Statistics and Service Programs", Section 1.4.

2 BILL VALIDATION - DOLLAR BILL ACCEPTOR

See also the circuit in the wiring diagram in the appendix of the "Technical Information".

The bill validator, after the bill has passed through and been accepted, sends as many pulses to the control unit as correspond to the value of the bill.

The output of the bill validator is connected to the control unit via ST 9, Pins 1 and 2. 1 pulse is sent to the control unit with 1 dollar and 5 pulses with 5 dollars.

The input of the bill validator is assigned to program step P55 and is to be programmed accordingly; see "Statistics and Service Programs", Section 1.4.

3 MARS ELECTRONIC COIN VALIDATOR

4 or 5 different coins be checked depending on the type. The three sensors in the validator register each separately the width, material composition and pressure of each deposited coin. If a deposited coin passes the sensors, the prepared data are passed on to a register and compared with the contents of a memory (PROM). If validation criteria are identical with a data set of the PROM, an internal "valid" signal is produced. Depending on the coin value it goes as output signal A1 to A5 to the plug of the PCB adapter (depending on type of validator, 15 or 13 poled). From there the signal goes via the 6-pole plug to control unit CD for processing.

3.1 Monetary Value Settings

The information in the "Operating Instructions" and the statistics and service program about monetary value settings refer to coin mechanisms with mechanical coin acceptors.

If a electronic validator has been installed, the monetary value settings in the individual program steps are assigned to corresponding output signals: P51 to signal A1 or A5, P52 to A3, P53 to A4, P54 to A2.

Notice: When inserting a coin during program steps 50-55, the program step (channel P51 to P55) assigned to the coin is automatically displayed in Display 1.

The monetary values are programmed in monetary value units: "001" $\hat{=}$ 0,10 DM, "010" $\hat{=}$ 1,- DM, "020" $\hat{=}$ 2,- DM, "050" $\hat{=}$ 5,- DM. No-used channels are programmed with "000".

3.2 Price Tables

Set the number of credit per monetary value in program steps P41 to P45 as described in the "Statistics" and Service Program, 1.3.2 Price Tables".

3.3 Other Settings/Information

When exchanging the control unit the programming has to be done in the new unit also.

Attention! When checking the monetary value settings in P54, the cabinet switch has to be pushed in; otherwise only one credit will be displayed instead of set coin value.

Notice: Non-used channels can be blocked. For this purpose the bridge of the corresponding channel (A1-A5 on the PCB) has to be disconnected or conductor A5 is not connected.

When exchanging please observe the following:

The validators of series B1 may have different mounting studs; compare the following text to Fig. 2.

■ The lower stud can be set on Pos. 1 or Pos. 2 needed. To loosen the stud position unscrew the cover (3) and pull down, (4) unlatch the stud, pull out and push it in at the desired position until it locks in.

■ If former validator was fastened with 2 screws, then exchange validator has to be fastened with plug-in studs as follows:

Drill a hole below into the plate with a diameter of 5,1 mm. Stick the stud positioned to the validator through the hole and secure it with clip 4,5 (712 011). Then screw on by upper fastening screw.

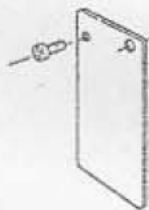

Fig. 1

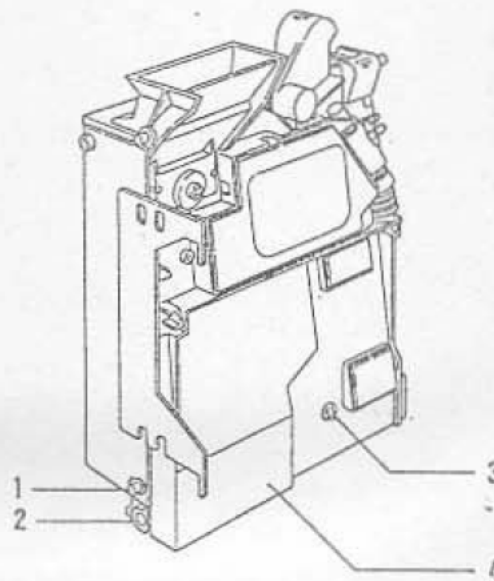
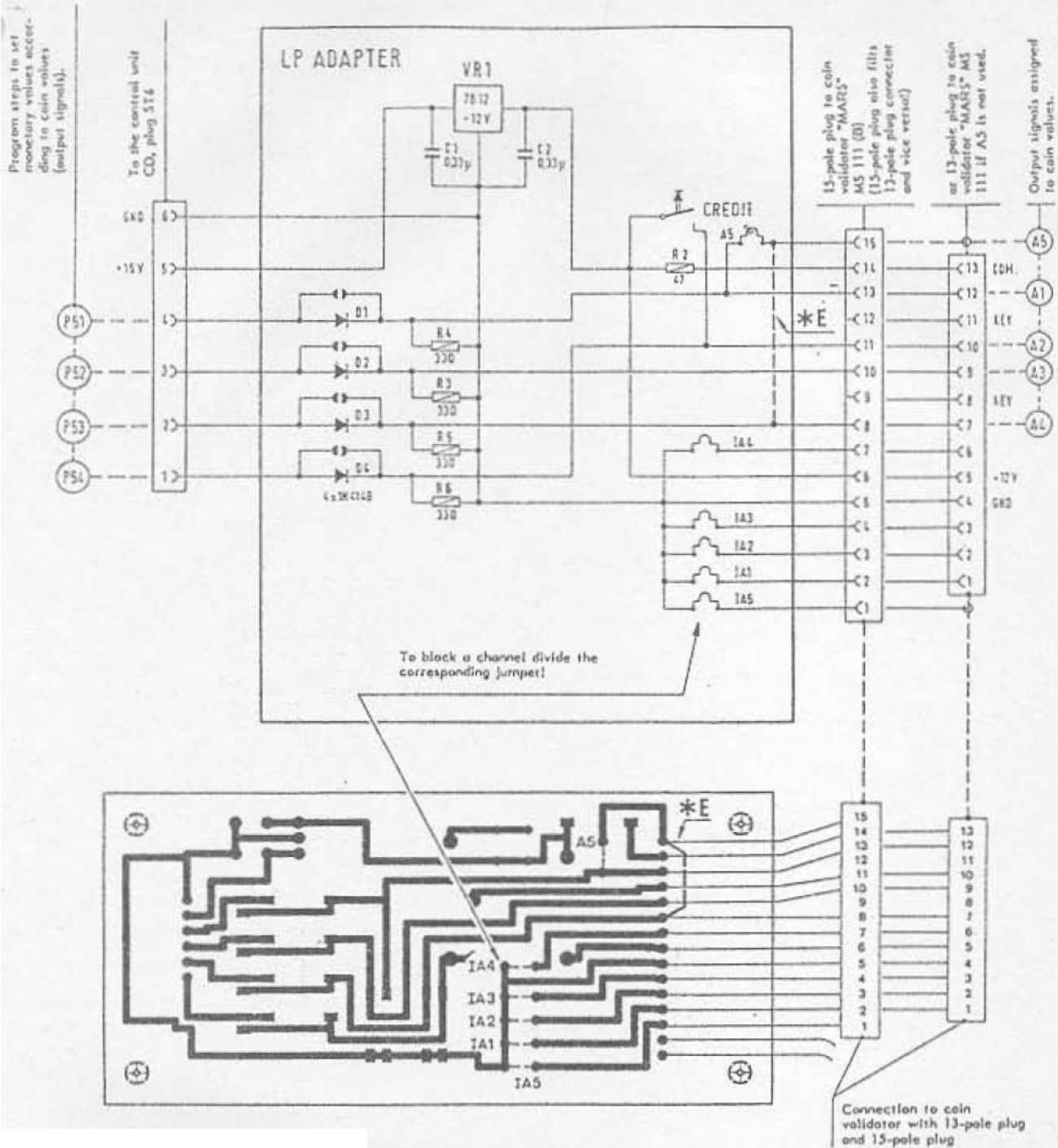

Fig. 2



MONETARY VALUE SETTINGS SEE BACK PAGE

Currency	Monetary Values P51 (A1/A5)	Coin Value P52 (A3)	P53 (A4)	P54 (A2)	Discon. Jumpers	Coin Validator - Type
Germany	050 $\bar{_}$ 5,- DM	010 $\bar{_}$ 1,- DM	000 $\bar{_}$ 00	020 $\bar{_}$ 2,- DM	IA4/IA5	GDE58 L00K/B1/GDE55L00C/B1
Great Britain	100 $\bar{_}$ 1 £ 100 $\bar{_}$ 1 £	020 $\bar{_}$ 20p 020 $\bar{_}$ 20p	010 $\bar{_}$ 10p 010 $\bar{_}$ 10p (rev) 10p (id)	050 $\bar{_}$ 50p 050 $\bar{_}$ 50p	IA5 A 5	GDB 31 L00C/GGBB1 L00C/ B1 GGBG3 L00C/02 * E
USA	100 $\bar{_}$ 1 \$	025 $\bar{_}$ 25 c	000 $\bar{_}$ 00	050 $\bar{_}$ 50 c	IA4	GUS 20 L00C
Australia	000 $\bar{_}$ 00 200 $\bar{_}$ 2 \$	100 $\bar{_}$ 1 \$ 000 $\bar{_}$ (50c)	020 $\bar{_}$ 20c 020 $\bar{_}$ 20c	200 $\bar{_}$ 2 \$ 100 $\bar{_}$ 1 \$	 IA3	GAS XX L00C B1/ GAS 1A L00C GAS 28 L00C
France	100 $\bar{_}$ 10 F 100 $\bar{_}$ 10 F (id) 10 F (rev)	020 $\bar{_}$ 2 F 020 $\bar{_}$ 2 F	010 $\bar{_}$ 1 F 010 $\bar{_}$ 1 F	050 $\bar{_}$ 5 F 050 $\bar{_}$ 5 F	 	GFR 19 L00C GFR 96 L00C / B1 * F
Denmark	000 $\bar{_}$ 00 100 $\bar{_}$ 10 dkr 100 $\bar{_}$ 10 dkr (rev) 200 $\bar{_}$ 20 dkr	050 $\bar{_}$ 5 dkr 010 $\bar{_}$ 1 dkr 050 $\bar{_}$ 5 dkr 050 $\bar{_}$ 5 dkr	010 $\bar{_}$ 1 dkr 000 $\bar{_}$ 0,25 dkr 010 $\bar{_}$ 1 dkr 010 $\bar{_}$ 1 dkr	100 $\bar{_}$ 10 dkr 050 $\bar{_}$ 5 dkr 100 $\bar{_}$ 10 dkr (id) 100 $\bar{_}$ 10 dkr	 IA4 	by 3-Canal GDK xx L00C by 4-Canal GDK 02 L00C by 4-Canal GDK 1A L00C GDK 1D L00C / GDK 1N L00C
Finland	000 $\bar{_}$ 00	050 $\bar{_}$ 5 MK	010 $\bar{_}$ 1 MK	000 $\bar{_}$ 00		GSF 1A L00C
Austria	200 $\bar{_}$ 20 S	050 $\bar{_}$ 5 S	010 $\bar{_}$ 1 S	100 $\bar{_}$ 10 S	A5/IA5	GAU 03 L00C
Neth.Antillen	000	000	100 $\bar{_}$ 1 NAF	000	A5/IA5	GNA 1 AL 00G / B1
Switzerland	050 $\bar{_}$ 5 Fr	010 $\bar{_}$ 1 Fr	000 $\bar{_}$ $\frac{1}{2}$ Fr	020 $\bar{_}$ 2 Fr	IA4/IA5	GCH 31 L00C / B1
Belgium	050 $\bar{_}$ 50 Fr 050 $\bar{_}$ 50 F 1 F (rev)	000 $\bar{_}$ 5 F (rev) 005 $\bar{_}$ 5 F (rev)	000 $\bar{_}$ 1 F 000 $\bar{_}$ 1 F (id)	020 $\bar{_}$ 20 F 020 $\bar{_}$ 20 F	IA3/IA4 (A3/A4) IA4/IA5	GBE 19 L00C / B1 GBE 25 L00C / B1 GBE 19 L00C / B1
Netherland	025 $\bar{_}$ 25 c	250 $\bar{_}$ 2 $\frac{1}{2}$ hfl	500 $\bar{_}$ 5 hfl	100 $\bar{_}$ 1 hfl		GNL 37 L00C / B1
Italy	050 $\bar{_}$ 500 L 050 $\bar{_}$ 500 L	000 (100 L) 010 $\bar{_}$ 100 L	000 (50 L) 000 (50 L)	020 $\bar{_}$ 200 L 020 $\bar{_}$ 200 L	IA3/IA4 IA4/IA5	GIT 06 L00C GIT 26 L00C / B1
USA	010 $\bar{_}$ (10c)	050 $\bar{_}$ (50c)	025 $\bar{_}$ 25c	100 $\bar{_}$ (1 \$)	IA5	GUS 1B L00C / B1
New Zealand	050 $\bar{_}$ 50 c	010 $\bar{_}$ 10 c 1 SHILLING	005 $\bar{_}$ 5 c	020 $\bar{_}$ 20		GNZ 03 L00C
Canada	010 $\bar{_}$ 10 c	100 $\bar{_}$ 1 \$	025 $\bar{_}$ 25 c	000		GCN 1A L00C
Spain	200 $\bar{_}$ 200 Pst	050 $\bar{_}$ 50 Pst	025 $\bar{_}$ 25 Pst	100 $\bar{_}$ 100 Pst		GES 1J L00C
Norway	100 $\bar{_}$ 10 Kr	010 $\bar{_}$ 1 Kr	(000 $\bar{_}$ $\frac{1}{2}$ Kr)	050 $\bar{_}$ 5 Kr	IA4	GN 008 L00C
Sweden	050 $\bar{_}$ 5 Kr	010 $\bar{_}$ 1 Kr	000 $\bar{_}$ (50 ökn)	010 $\bar{_}$ 1 Kr	IA4	GSW 09 L00C
Greece	(010) MP drad	050 $\bar{_}$ 50 Dr	020 $\bar{_}$ 20 Dr	000		GGR 1C L00C
Korea	000	010 $\bar{_}$ 10 NTS	005 $\bar{_}$ 5 NTS	000		GTW 1A L00C
Mexico	000	000	010 $\bar{_}$ 1000 P	000		GME 1A L00C
Hong Kong	050 $\bar{_}$ 5 \$	010 $\bar{_}$ 1 \$	000	020 $\bar{_}$ 2 \$		GHK 1A L00C / B1
Hungaria	020 $\bar{_}$ 20 F	005 $\bar{_}$ 5 F	000	010 $\bar{_}$ 10 F	IA4/IA5	GHU 1B L00C./ B1
Thailand	000	000	005 $\bar{_}$ 5 Baht	000		GTH 1A L00C / 02

* F A5 and IA 5 closed

* E additional jumper from
pin 15 to 8
(A5) (A4)

UNIT DESCRIPTION

CONTROL UNIT

FOR NSM-PHONOGRAPGHS

ES IV-CD TECHNOLOGY

to
Technical Information, Assy

174 903	SILVER CITY
174 831	SILVER SKY
174 486	FASCINATION
175 274	SOUNDMASTER
175 040	FIREBIRD/COUNTRY
176 046	THE PERFORMER "GRAND"

NSM
Aktiengesellschaft
Saarlandstraße 240
6530 Bingen am Rhein

4

Page 401-408/411

INDEX

- 1 FUNCTION
- 1.1 Control unit
- 1.2 Processor
- 1.3 Reset
- 1.4 Low voltage recognition and power off
- 1.5 I/O (Input/output)
- 1.6 Output enable
- 1.7 Service plug

Spare parts list

Schematics CONTROL UNIT CD

1 FUNCTION

1.1 CONTROL UNIT

The heart of the control and credit unit is a microprocessor from the proven Rockwell 6500 family.

All unit functions such as keyboard, display, remote control, carriage (light generator / organ), coin mechanism, title indication etc. are controlled by this unit.

Different types of malfunctions are recognized and reported as such on the display. All statistical data such as phonograph status, price adjustments and bookkeeping data are stored in the CONTROL UNIT. These as well as credits remaining are stored when the power is switched off.

Connection of the DATA PRINT is provided at Plug 11.

A number of service programs allow the read-out of statistical data, individual as well as test programs.

1.2 Processor

The processor consists primarily of the microprocessor IC 1, the EPROM IC 2, the battery RAM IC 3 and the I/O component IC 4. Address coding occurs via IC 12.

The tact generator consists of a quartz oscillator with Q 1 (4 MHz) and the frequency divider (1:4) IC 14.

1.3 Reset

The Zener diode ZD 2 with transistors T 1 and T 2 serves to activate the reset when U (+5 V) is less than 4,6 V.

Transistor T 2 with its antenna connection serves to recognize static discharges and interferences.

When T 2/C is LOW, reset is activated via IC 16, Pin 10, Pin 11. If T 2/C is HIGH, reset remains stored for approx. 200 msec. over the subsequent monoflop 1/2 IC 13 with timing components R 14, C 19 vis IC 16, Pin 9.

1.4 Low Voltage Recognition and Power Off

Resistors R 15, R 16, R 18 from a voltage divider for low voltage recognition.

R 17 and D 6 generate a hysteresis when the voltage rises again. The positive edges (10 msec. at 50 Hz, 8.3 msec. at 60 Hz) coming from T 3/C retrigger the monoflop 1/2 IC 13 with timing components R 20, C 20 (approx. 20 msec.) and IC 13, Pin 4 at LOW.

This signal is monitored by the processor via IC 4, Pin 6.

When IC 4, Pin 6 is HIGH, the program is prematurely deactivated.

1.5 I/O (Input/Output)

All I/O operations are controlled via a serial bi-directional interface (IC 4, Pin 18 = CLOCK; IC 4, Pin 19 = DATA). IC 18 selects the different input channels; IC 11 decodes the load impulses for the output channels.

Output: IC 5 and IC 6 are output ports.

Resistors R 22-40 together make two D/A converters. The DC signals obtained thereby control the volume and are conducted to the amplifiers via plugs ST 2, Pin 2, Pin 3.

Input: IC 8 and IC 9 are input ports.

The resistors, in sequence to the input pins, protect the CMOS components.

Serial interfaces are available:

At ST 3 for control of the light generator

At ST 4 for display and keyboard

At ST 8 for control of CD changer

At ST 10 for control of Title Indication.

1.6 Output - Enable

A clock signal is sent by IC 4, Pin 5. Capacitor IC 26 is charged keeps IC 15, Pin 8 at LOW.

If the clock signal does not occur, IC 15, Pin 14 is LOW and OE of IC 5 and IC 6 is inactive (outputs in tree state).

OE also become inactive via D 1 when reset (IC 16, Pin 11) becomes LOW.

1.7 Service Plug

Plug ST 11 serves to connect with the DATA PRINT.

CONTROL UNIT CD

NSM

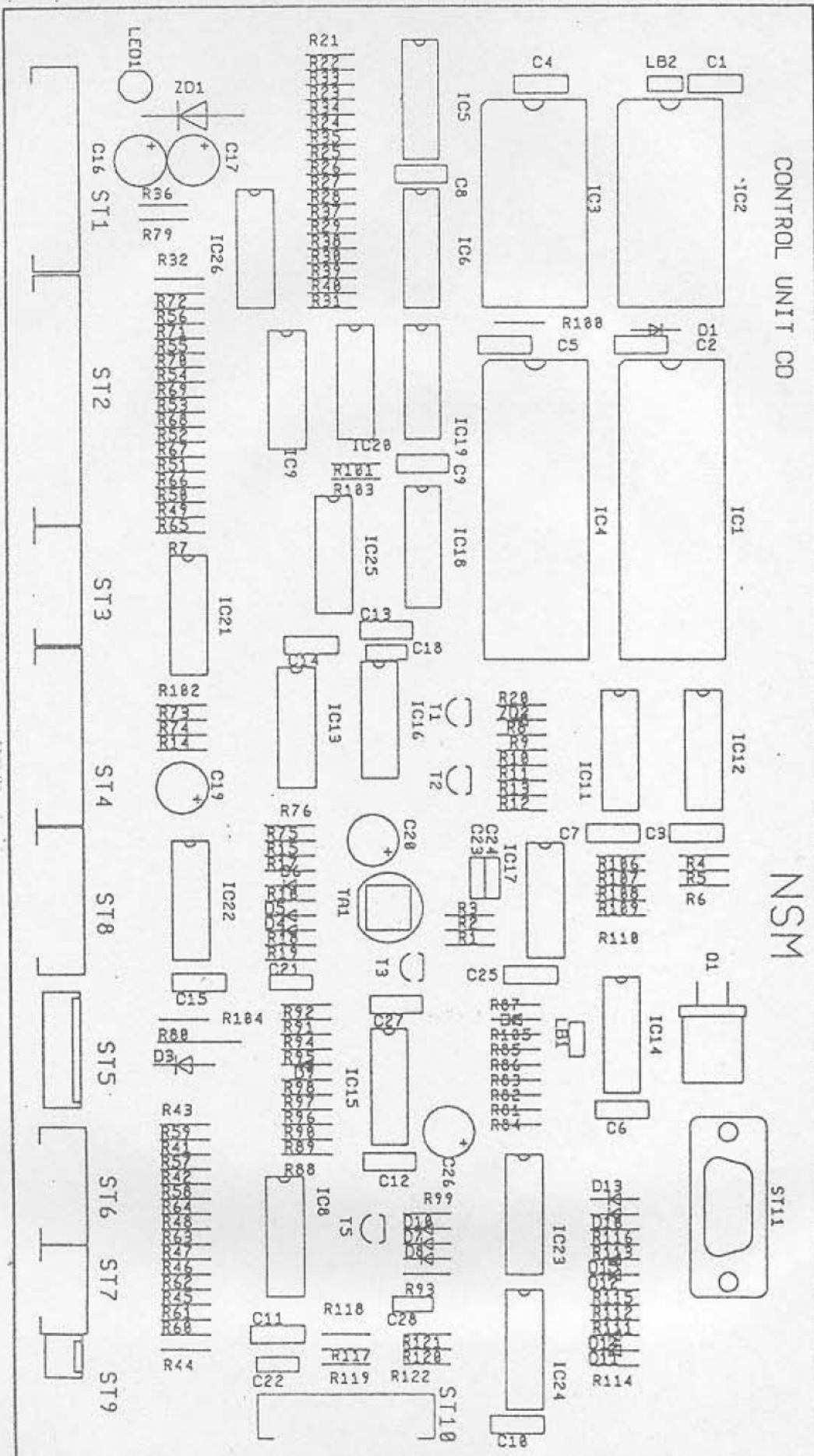

SPARE PARTS LIST

POS.	PART-No.	DESCRIPTION	DATA	QTY
	174 873	<u>CB-CONTROL UNIT CD, ASSY</u>		1
ST 07	225 651	PIN PANEL	4 prongs	1
ST 03, 06	225 652	PIN PANEL	6 prongs	2
ST 08	225 653	PIN PANEL	8 prongs	1
ST 04	225 654	PIN PANEL	10 prongs	1
ST 01	225 655	PIN PANEL	12 prongs	1
ST 02	225 656	PIN PANEL	15 prongs	1
ST 09	225 439	PIN PLUG	3 prongs	1
ST 05	225 444	PIN PLUG	8 prongs	1
ST 11	225 828	D-SUBMINIATURE-CONNECTOR	SLEEVE 9 prongs	1
Q 1	221 535	OSCILLATOR QUARTS	4 MHZ	1
IC 3	222 446	IC-SOCKET	24 prongs	>
	231 423	IC-MEMORY	MK 48 Z 12-20	1
IC 2	222 447	IC-SOCKET	28 prongs	>
	175 102	IC-MEMORY Program 007	AM 27 256 DC	1
IC 1, 4	222 448	IC-SOCKET	40 prongs	2
IC 1	231 413	IC-MICROCOMPUTER	R 65 C 02 - P 2	1
IC 4	231 415	IC-MICROCOMPUTER	R 65 C 22 - P 2	1
IC 8, 9	221 763	IC-CMOS	HEF 4021 B	2
IC 5, 6	221 771	IC-CMOS	HEF 4094 B	2
IC 21-23	221 541	IC-CMOS	F 4049 BC	3
IC 16	221 665	IC-TTL	SN 74 LS 00	1
IC 19	221 525	IC-TTL	SN 74 LS 03	1
IC 17	221 652	IC-TTL	SN 74 LS 04	1
IC 14, 20	221 705	IC-TTL	SN 74 LS 74 A	2
IC 13	221 792	IC-TTL	SN 74 LS 123	1
IC 12	221 653	IC-TTL	SN 74 LS 139	1
IC 18	221 852	IC-TTL	SN 74 LS 151	1
IC 11	221 796	IC-TTL	SN 74 LS 138	1
IC 15	221 813	IC-LINEAR	LM 339	1
IC 26	221 497	IC-LINEAR	ULN 2003 A	1
D 3	221 115	SI-DIODE	1 N 4004	1
D 1, 2,				>
4-16	221 114	SI-DIODE	1 N 4148	16
ZD 1	221 539	TRANZORB DIODE	IC TE-5	1
ZD 2	221 948	ZENER-DIODE	ZPD 3,9	1
LED 1	221 466	LIGHT EMITTING DIODE	LR 3160-F	1
T 1, 2	221 757	TRANSISTOR	BC 547 B	2
T 3, 5	221 283	TRANSISTOR	BC 212 B	2

SPARE PARTS LIST

POS.	PART-No.	DESCRIPTION	DATA		QTY
C 22	220 181	CER.-CAPACITOR	47 pF		1
C 23	220 242	CER.-CAPACITOR	68 pF		1
C 24	220 185	CER.-CAPACITOR	270 pF		1
C 18, 28	220 263	CER.-CAPACITOR	1000 pF		2
C 21	220 341	CER.-CAPACITOR	4700 pF		1
C 1-15, 25, 27	220 334	MKT-CAPACITOR	0,1 µF	63 V	17
C 19, 20, 26	220 159	LYTIC	4,7 µF	63 V	3
C 17	220 162	LYTIC	10 µF	63 V	1
C 16	220 160	LYTIC	100 µF	10 V	1
R 8, 9, 116	221 600	RESISTOR	100 Ω	½ W	3
R 12, 19, 79	221 099	RESISTOR	470 Ω	½ W	3
R 93	221 622	RESISTOR	820 Ω	½ W	1
R 10, 87	221 029	RESISTOR	1 KΩ	½ W	1
R 13	221 031	RESISTOR	2,2 KΩ	½ W	1
R 2-5, 102-104, 106-110	221 033	RESISTOR	3,3 KΩ	½ W	13
R 84, 88, 89, 94, 110, 101, 105, 113	221 034	RESISTOR	4,7 KΩ	½ W	8
R 1, 15	221 172	RESISTOR	8,2 KΩ	½ W	2
R 11, 18, 20, 47, 74, 76, 82, 83, 90-92, 95, 111, 112, 114, 115	221 035	RESISTOR	10 KΩ	½ W	16
R 16, 21, 27, 33-40, 73, 75, 85	221 604	RESISTOR	22 KΩ	½ W	14
R 17	221 601	RESISTOR	27 KΩ	½ W	1
R 22-26, 28-32, 41-72, 98, 99	221 038	RESISTOR	47 KΩ	½ W	44
R 14, 81, 86, 95	221 048	RESISTOR	100 KΩ	½ W	4
R 80	221 273	RESISTOR	10 Ω	½ W	1

Fernwahlschluß
CONNECTION REMOTE SELECTION

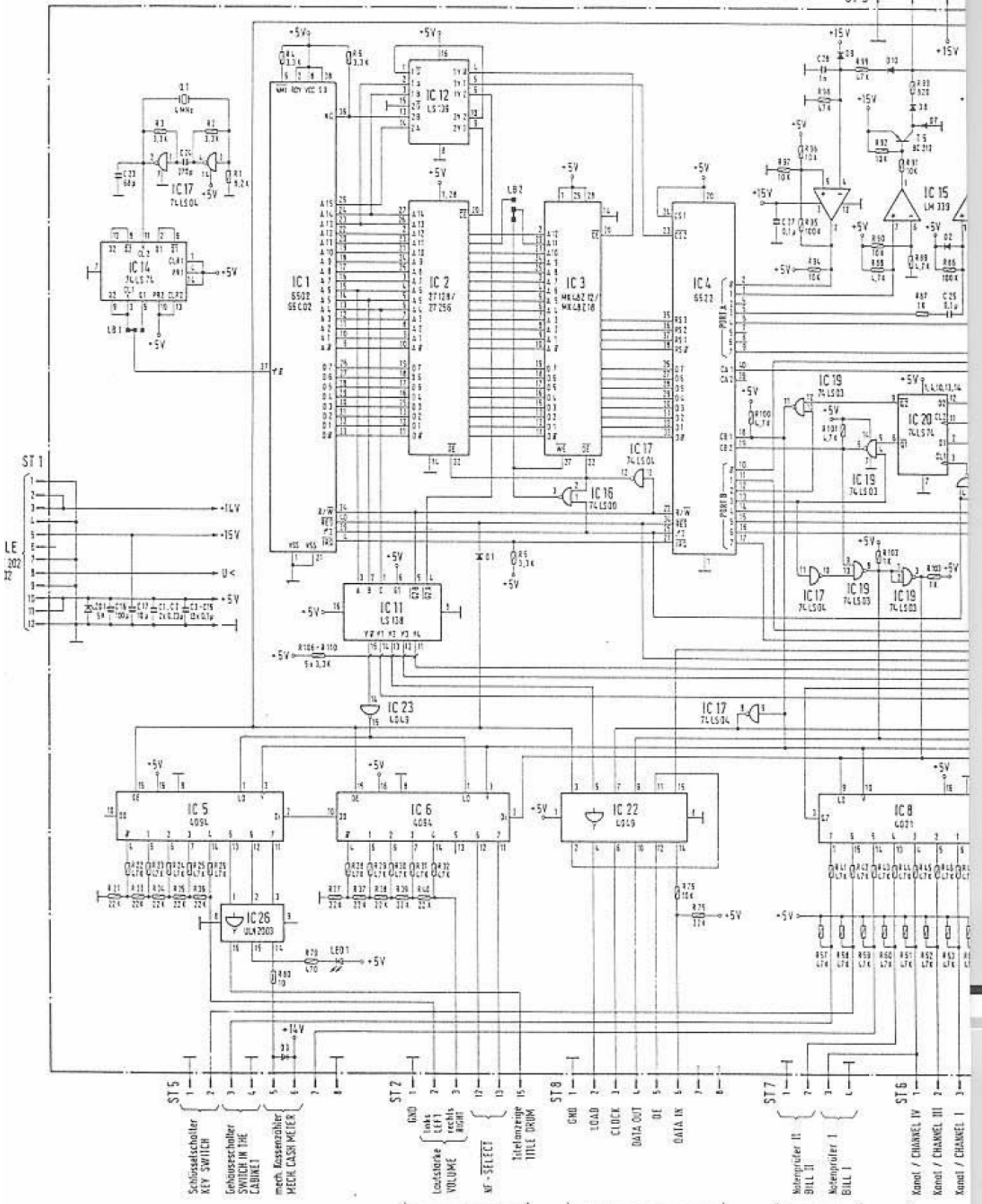

174 902 / 174 830 / 174 485 / 175 275 / 175 039
 174 903 / 174 831 / 174 486 / 175 274 / 175 040
 174 904 / 174 832 / 174 487 / 175 273 / 175 041

CENTRALE
 Stecker ST 201
 PLUG ST 201

WECHSLER-ADAPTER
 Stecker ST 6 / PLUG ST 6

Notenprüfer
 BILL ACCEPTOR

Münza
 COIN MEC

ST 5
 Schlißschalter
 KEY SWITCH
 Einbauschalter
 SWITCH IN THE
 CABINET
 mech. Kassenzähler
 MECH. CASH METER

ST 2
 links
 LEFT
 rechts
 RIGHT
 VOLUME
 MF-SELECT
 Titelmagnet
 TITLE DRUM

ST 8
 GND
 LOAD
 CLOCK
 DATA OUT
 DE
 DATA IN

ST 7
 Notenprüfer II
 BILL II
 Notenprüfer I
 BILL I

ST 6
 Kanal / CHANNEL IV
 Kanal / CHANNEL III
 Kanal / CHANNEL I

SERVICE-Auswertung
EVALUATION OF SERVICE PROGRAMS

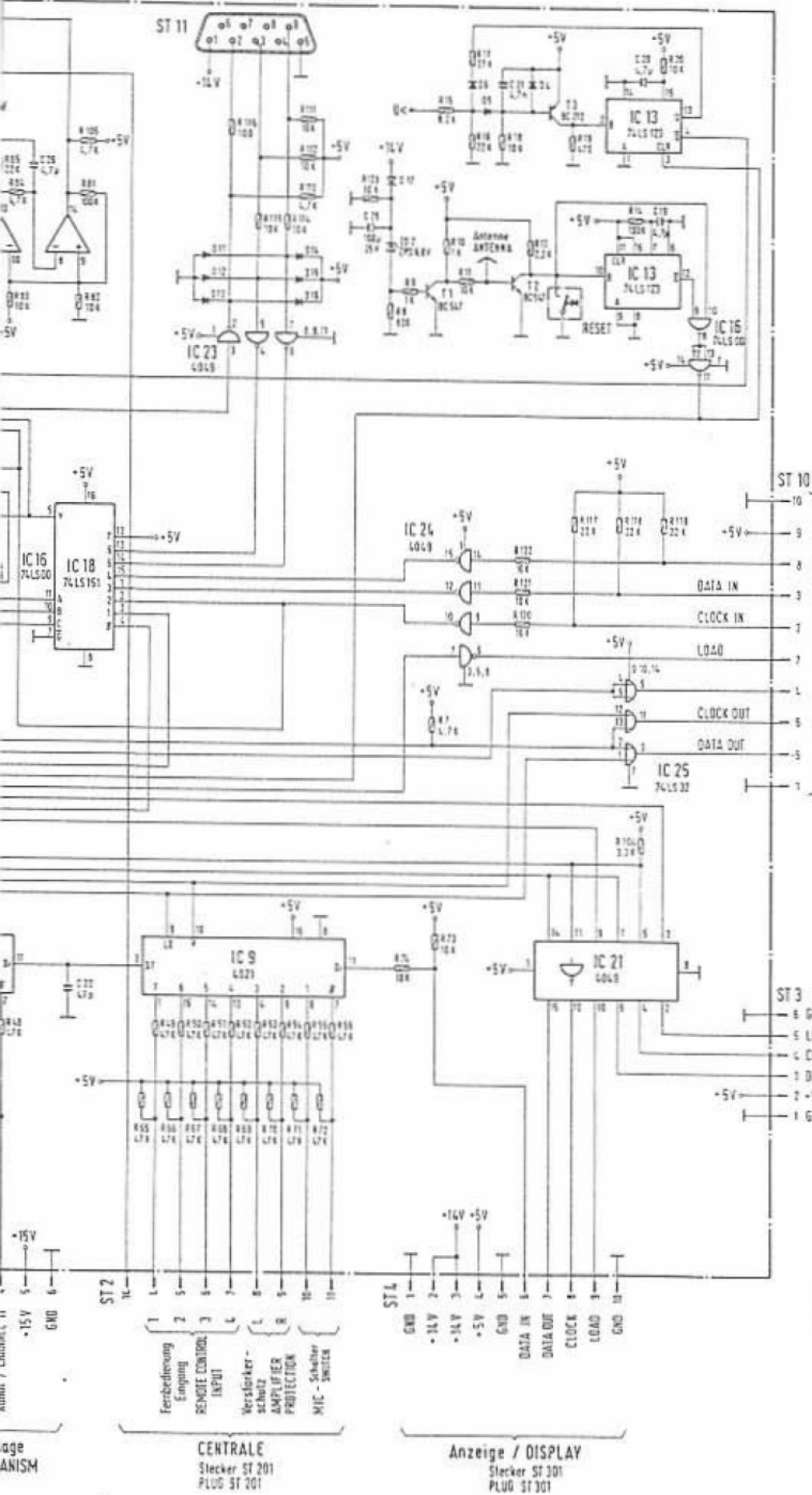

Titelanzeige II
TITLE INDICATOR II
Stecker ST 1
PLUG ST 1

ST 3
4 GND
5 LOAD
6 CLOCK
7 DATA OUT
8 -5V
9 GND
Lichtspiel
-LIGHT GENERATOR / ORGAN
Stecker ST 704
PLUG ST 704

- Gerüstete Bauteile sind nicht eingebaut!
DOTTED COMPONENTS ARE NOT INSTALLED!
- von unten gesehen
BOTTOM VIEW
- IC 74LS123
- IC 6049
- 74LS00
- 74LS151
- 6049

ÄNDERUNGEN IM SINNE DES TECHN. FORTSCHRITTES VORBEHALTEN
JEDOCHE KEINE NACHRÜSTPFLICHT!
SUBJECT TO TECHNICAL MODIFICATION WITHOUT OBLIGATION
TO MODIFY EQUIPMENT ALREADY DELIVERED!

MUSIKAUTOMATEN
PHONOGRAPHS **ES IV-CD** TECHNOLOGY

Schaltbild
WIRING DIAGRAM **CONTROL UNIT CO**

Doc	Ver	Rev	Werk	Werk
12 26 83	Braun	2		

UNIT DESCRIPTION
DISPLAY/KEYBOARD
FOR NSM-PHONOGRAPHS

ES IV-CD TECHNOLOGY

to
Technical Information, Assy

174 903	SILVER CITY
174 831	SILVER SKY
174 486	FASCINATION
175 274	SOUNDMASTER
175 040	FIREBIRD/COUNTRY
176 046	THE PERFORMER "GRAND"

NSM
Aktiengesellschaft
Saarlandstraße 240
6530 Bingen am Rhein

5

Page 501-505/511

INDEX

- 1 FUNCTION
- 1.1 Display
- 1.2 Keyboard

Spare parts list

1 FUNCTION

1.1 Display

The shift registers IC 301 through IC 303 are the output ports for the display control.

The display is operated in the multiplex mode.

The segment information is prepared for one digit with IC 302 and IC 303 via drivers IC 308 and IC 309.

The transistors T 303 through T 305 are controlled by IC 307 via IC 301 and switch on the appropriate multiplex level for 4 milliseconds.

Resistors R 332 to R 345 determine the segment current.

Lamps L 1 to L 5 are controlled statically via IC 307, Pin 12 and 14 and IC 306, Pin 19, 11, 12.

Resistors R 325 to R 329 limit the transient current.

The load signal for the output shift registers is monitored by circuit IC 306, Pin 4 and 13; R 306; C 303; D 301.

During the duration of the load signal the display is dark.

C 303 is discharged via D 301 and IC 306, Pin 13.

OE of IC 301 to IC 303 becomes LOW and thereby inactive.

If no load signal occurs, OE becomes inactive via R 305.

Capacitor C 302 avoids lighting up of the digits after switching on.

1.2 Keyboard

IC 301 is an input port for the keyboard which is connected to plug ST 302.

The circuit with diodes D 302 - D 307 and transistors T 306, T 307 codes the keyboard matrix to a 4-bit signal combination.

SPARE PARTS LIST

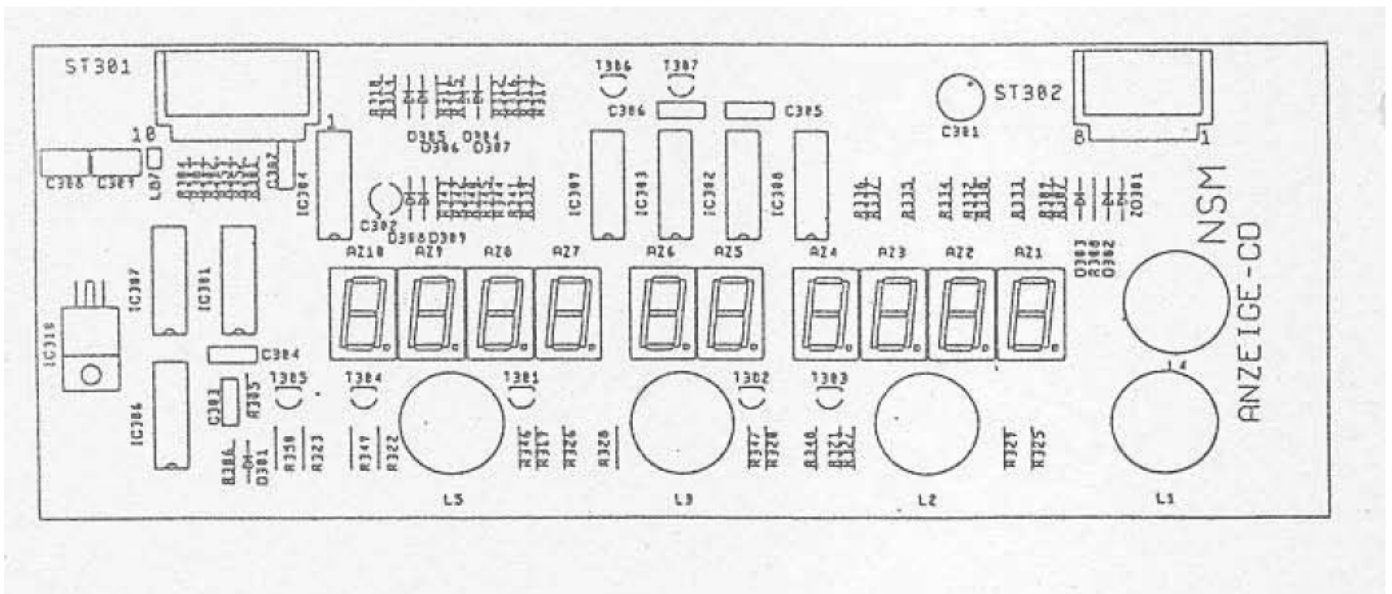

SPARE PARTS LIST

POS.	PART-No.	DESCRIPTION	DATA	QTY
	173 664	<u>CB-DISPLAY CD, ASSY</u>		1
ST 302	225 663	PIN PANEL	8 prongs 90°	1
ST 301	225 664	PIN PANEL	10 prongs 90°	1
AZ 1-8	231 416	DISPLAY	TD SL 5150	10
	173 384	TUBUS		1
	171 629	HOLDER		4
IC 310	221 573	IC-VOLTAGE	12 V 1 A	1
ST 301-303	221 771	IC-CMOS	HEF 4094 B	3
IC 304	221 763	IC-CMOS	HEF 4021 B	1
ST 306-309	221 497	IC-LINEAR	ULN 2003 A	4
D 301-307	221 114	SI-DIODE	1 N 4148	7
ZD 301	231 079	ZENER-DIODE	ZPD 4,7	1
T 301-306	231 240	SI-TRANSISTOR	BC 636 F	5
T 306, 307	221 283	SI-TRANSISTOR	BC 212 B	2
T 303-307	220 334	MKT-CAPACITOR	0,1 µF 63 V	5
C 308, 309	220 332	MKT-CAPACITOR	0,33 µF 63 V	2
C 302	220 249	LYTIC	1 µF 63 V	1
C 301	220 162	LYTIC	10 µF 63 V	1
R 301	221 611	RESISTOR	10 Ω ½ W	1
R 306, 332-350	221 627	RESISTOR	1,2 KΩ ½ W	20
R 302-304, 307-309, 314-317, 319-323, 354	221 033	RESISTOR	3,3 KΩ ½ W	16
R 310-313	221 038	RESISTOR	47 KΩ ½ W	4
R 305	221 009	RESISTOR	1 MΩ ½ W	1
R 325-329	231 366	MET.-RESISTOR	10 Ω ½ W	5
	173 900	KEY BOARD, ASSY		1

CONTROL UNIT
Stecker ST 4
Stecker ST 4

ST 301

LOAD
CLOCK
DATA IN
DATA OUT

R 301 10
+5V
+14V
C 301 10 µF 63V

R 300 22
L 6
12V
2W

Tastatur - Beleuchtung
ILLUMINATION KEY BOARD
Nur wenn vorhanden.
ONLY IF AVAILABLE.

IC 306
ULN 2003

+5V
R 306 1,2K
C 303 0,1 µF
D 308
R 305 1M
D 301
C 302 1 µF

R 304 3,3K
R 303 3,3K
R 302 3,3K

IC 304
4021
+5V
C 307 0,1 µF

R 370 47K
R 311 47K
R 312 47K
R 313 47K

R 314 3,3K
R 315 3,3K
R 316 3,3K
R 317 3,3K

IC 301
4094

IC 307
ULN 2003

+14V

R 350 1,2K
R 349 1,2K
R 348 1,2K
R 347 1,2K
R 346 1,2K

T 306
T 307
2 x BC 212 B
+12V
R 308 3,3K
R 307 3,3K
D 302
D 303
R 309 3,3K
D 306
D 304

Leiterplatte Anzeige
CIRCUIT BOARD DISPLAY

ST 302

Leiterplatte Tastatur
CIRCUIT BOARD KEY BOARD

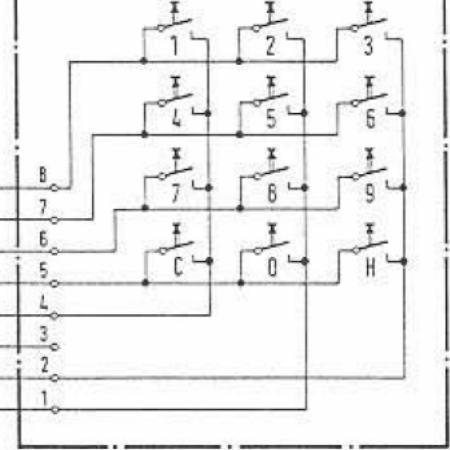

174 902 / 174 630 / 174 485 / 175 275 / 175 039
174 903 / 174 831 / 174 486 / 175 274 / 175 040
175 592 / 175 594 / 175 599 / 176 043 / 175 593

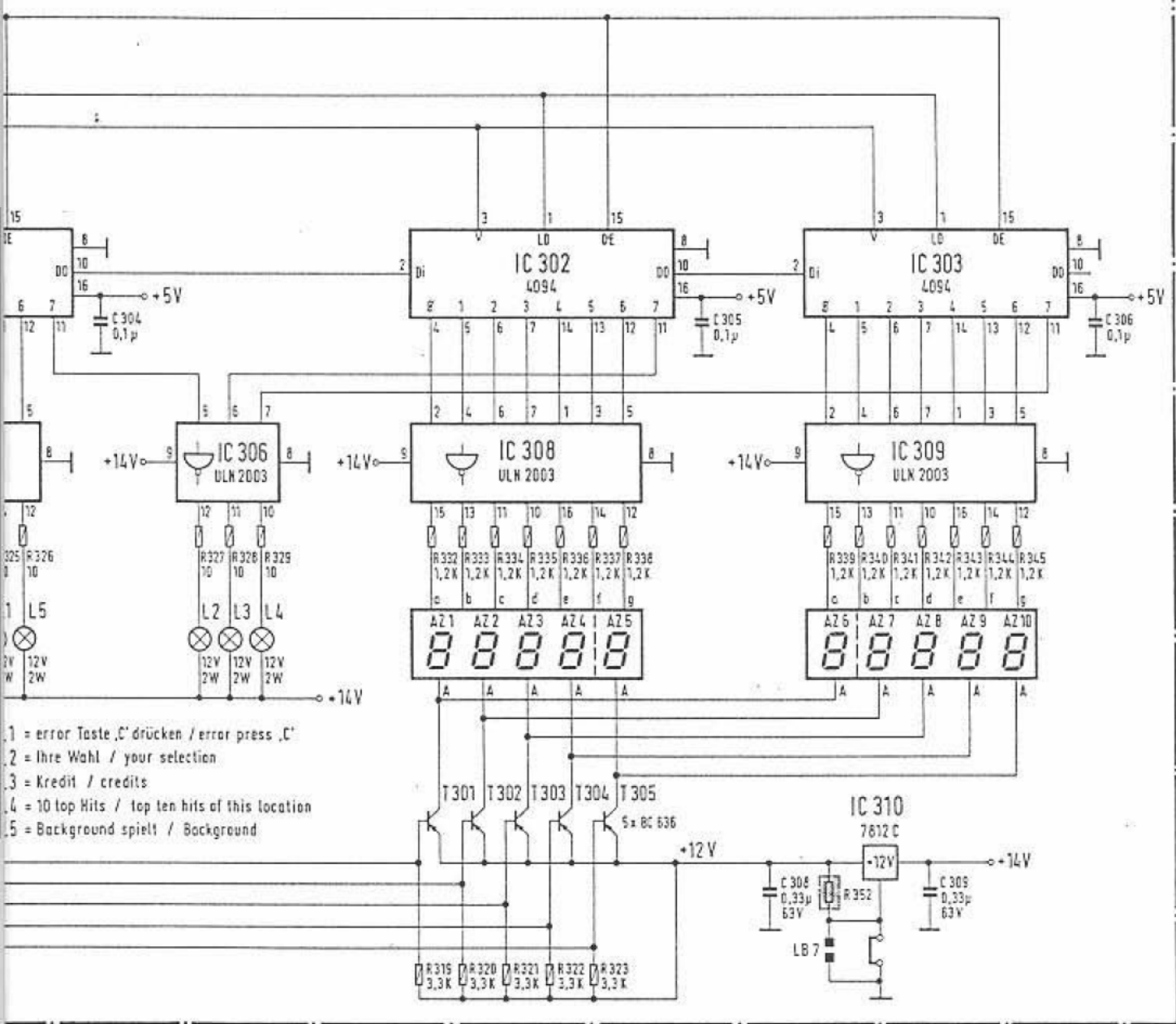

- 1 = error Taste ‚C‘ drücken / error press ‚C‘
- 2 = Ihre Wahl / your selection
- 3 = Kredit / credits
- 4 = 10 top Hits / top ten hits of this location
- 5 = Background spielt / Background

Draufsicht: Display
TOP VIEW: DISPLAY

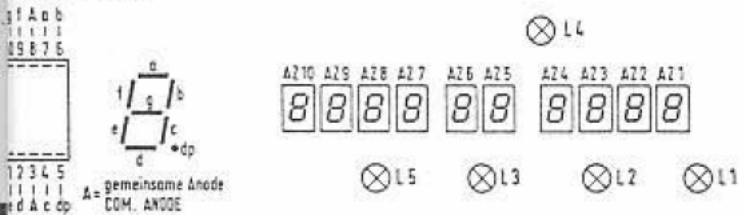

Draufsicht: Spannungsregler IC 310
TOP VIEW: VOLTAGE REGULATOR IC 310



von unten gesehen
BOTTOM VIEW

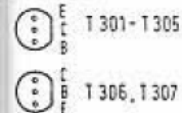

- ZENER-DIODE
- 1N4148
- 1 W
- 1/2 W

gerasterte Bauteile sind nicht eingebaut!
DOTTED COMPONENTS ARE NOT INSTALLED!

ÄNDERUNGEN IM SINNE DES TECH. FORTSCHRITTES VORBEHALTEN,
JEDOCH KEINE NACHRÜSTPFLICHT!

SUBJECT TO TECHNICAL MODIFICATION WITHOUT OBLIGATION
TO MODIFY EQUIPMENT ALREADY DELIVERED!



MUSIKAUTOMATEN **ES IV-CD** TECHNOLOGY
PHONOGRAPHS

Schaltbild Anzeige / Tastatur
WIRING DIAGRAM DISPLAY / KEY BOARD

Oct	20 03. 89	Gez	Braun	Zeich	Weg	Gepr	Mann
-----	-----------	-----	-------	-------	-----	------	------

*TECHNICAL INFORMATION
FOR NSM-PHONOGRAPH*

CD GALAXY

ES IV-CD TECHNOLOGY

1	TECHNICAL INSTRUCTIONS
2	OPERATING INSTRUCTIONS
3	STATISTIC and SERVICE PROGRAMS
4	CONTROL UNIT
5	DISPLAY/ KEY BOARD
6	CENTRAL UNIT
7	OUTPUT STAGE
8	CD-CHANGER
9	TITLE DRUM
10	COIN and BILL ACCEPTOR
11	REMOTE CONTROL
12	
13	OUTPUT TRANSFORMER
14	TROUBLE SHOOTING
15	ACCESSORIES
16	
17	
18	
19	

0



NSM
APPARATEBAU
GmbH & Co. KG
6530 Bingen
Saarlandstraße 240
Telefon 06721/4070

PART-No

209 817 B

GENERAL

The modern technology of this new NSM phonograph "GALAXY CD" with CD changer assures the highest functional reliability. A practical diagnostic system is available for maintenance and service.

In order to assure satisfactory operation at all times we recommend reading the technical descriptions carefully so that you are familiar with all service operations.

The following technical documents include:

- 1 The "TECHNICAL INSTRUCTIONS" with important information regarding set-up of the phonograph, technical data, location of the components, the "cabinet" parts list as well as the electrical plan and various wiring diagrams.
- 2 The "OPERATING INSTRUCTIONS" with explanations regarding play and settings as well as short instructions for statistics and service programs.
- 3 The "STATISTICS and SERVICE PROGRAMS" as well as test programs and error displays. The convenient service programs help the user in maintenance and control and permit the transfer of bookkeeping and technical data into the new NSM recording device and the printer "NSM DATA PRINT."
- 4-13 The "UNIT DESCRIPTIONS" for control unit, display/keyboard, central unit, output stage, CD changer, title display, electronic coin mechanism and bill validator, remote control and output transformer with their functions and, where applicable, wiring diagram and parts list.
- 14 "TROUBLE-SHOOTING CHART," a description of errors, error displays as well as flow chart to determine errors.
- 15 "ACCESSORIES," information on genuine NSM accessories with instructions for installation and exercising options.

The information and illustrations contained in these technical documents are up to date at the time of publication.

SUBJECT TO TECHNICAL MODIFICATION WITHOUT OBLIGATION TO MODIFY EQUIPMENT ALREADY DELIVERED!

Copyright by
NSM Apparatebau GmbH & Co. KG, D-6530 Bingen/Rhein 1, Germany

No reprint in full or part unless approved.

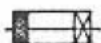

"Caution: Replace With Same Typ Fuses"

"Attention: Utiliser Un Fusible De Rechange de Même Typ".

The CD-Player with Laser pick-up used in this phonograph is in compliance with the regulations of the F.D.A.

Accession number 8 320 425

Supplement 15

002

This equipment complies with the requirements in Part 15 of FCC Rules for a Class A Computing Device. Operation of this equipment in a residential area may cause unacceptable interference to radio and TV reception requiring the Operator to take whatever steps are necessary to correct the interference.

*TECHNICAL INSTRUCTIONS
FOR NSM-PHONOGRAPHS*

CD GALAXY

ES IV-CD TECHNOLOGY



NSM
APPARATEBAU
GmbH & Co. KG
6530 Bingen
Saarlandstraße 240
Telefon 067 21/4070

PART-No -
209818

INDEX

- | | | | |
|------|--------------------------|-------|------------------------|
| 1. | PLEASE READ INSTRUCTIONS | 3.2. | Music power |
| 1.1. | Transport damages | 3.3. | Fuses |
| 1.2. | Keys | 3.4. | Lighting |
| 1.3. | Transport devices | 3.5. | Credit/Cash input |
| 1.4. | Power connection | 3.6. | Keyboard |
| 1.5. | Title strips and CD's | 3.7. | Displays |
| 2. | LAYOUT OF UNITS | 3.8. | CD changer |
| 2.1. | Display/Keyboard | 3.9. | Loudspeakers |
| 3. | SPECIFICATIONS | 3.10. | Special features |
| 3.1. | Electrical data | 3.11. | Dimensions |
| | | 4. | LOUDSPEAKER CONNECTION |

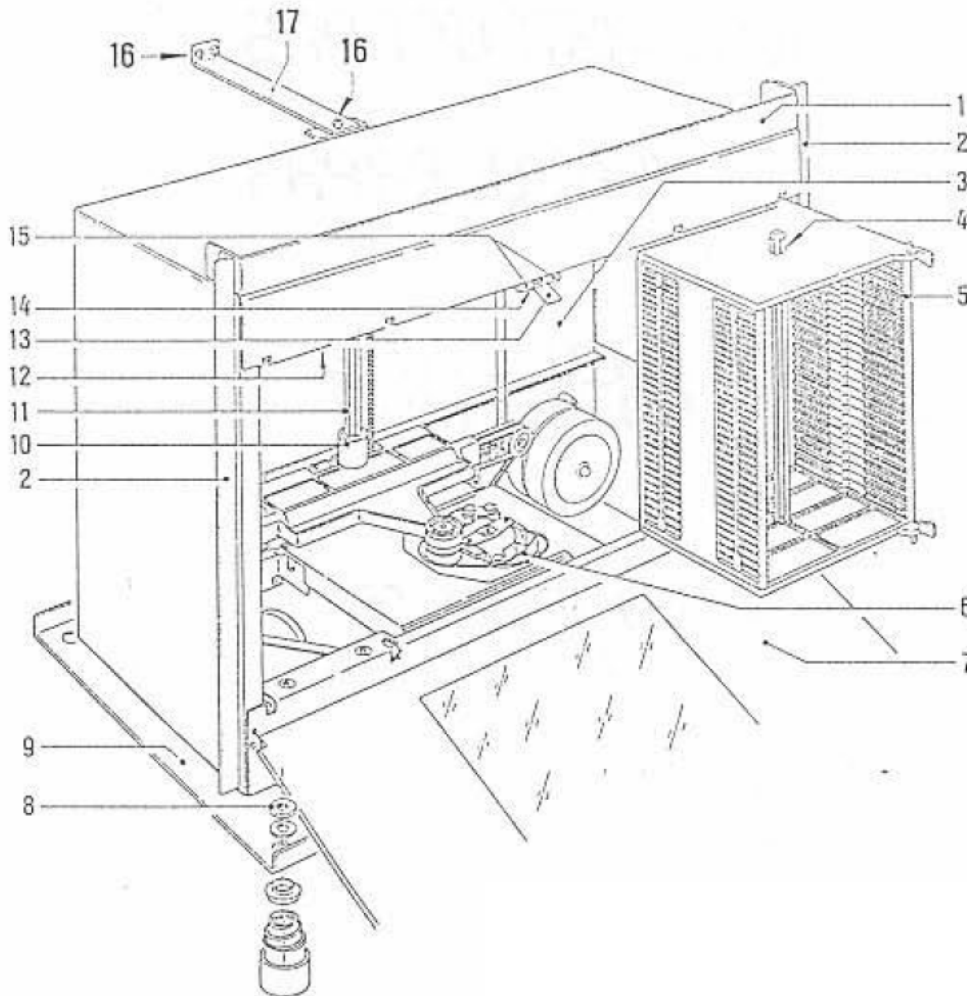
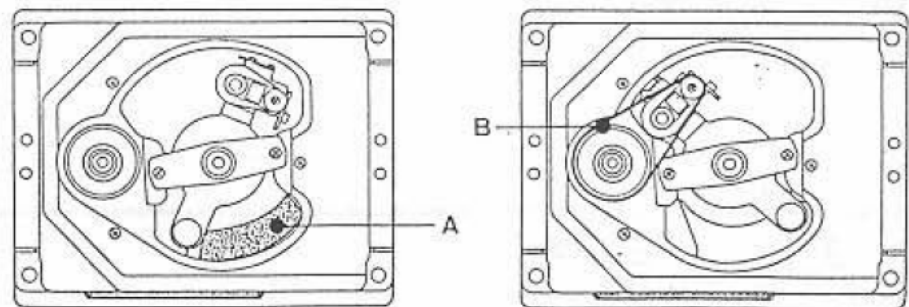

Fig. 1



1. PLEASE READ INSTRUCTIONS

1.1. Transport Damages

If external damage due to transport is noticed, this should at once be recorded on the delivery slip and endorsed by the person making the delivery.

The manufacturer is not liable for damages caused during transport!

1.2. Key

One cabinet key and one cashbox key are taped to the front panel. The other keys are in the cashbox. Upon opening the cabinet lock on the right side the lid may be lifted fully upwards.

1.3. Transport Devices

Devices for safety and protection during transport have to be removed before operating the phonograph. Prior to any further transit the safety and protection devices have to be replaced.

- Remove cardboard strip (13) - which deters the accidental opening of the locking mechanisms of both magazines - after loosening fastening screw (14).
If the holding bracket of the PCB's (12) is to be loosened, the fastening screw has to be completely removed.
- Press the service keys (15) to the center and swing out the left and right magazine (5).
- Remove slotted plastic pipe from the lift axle (11), grip the lift close to lift axle (10) and pull up.
- Remove cover from playing mechanism.
Remove foam padding (A) or rubber ring (B), if applicable, which protect the radial motor.
Do not insert foam padding on the cable side if safety devices have to be installed for further transport.
- Loosen CD changer by turning the four nuts (8) so far back from the bottom plate (9) that the changer moves freely.

Keep transport devices in a suitable location in cabinet for later transport!

Information for return transport of CD changer:

When exchanging the changer, it may only be transported in the original packaging!

- Remove magazine, push the proper button (15) outwards and remove the unit.
Inserted CD's can be kept from falling out when the plastic pipe from the lift axle as well as a second one from the enclosed package is put through the opening (4) and all CD's of the magazines.
- Remove design parts: Take out front glass (7),
take off front and side trim plates.
- Unscrew bottom plate from changer.
- Remove inside lighting; unscrew L-bracket with the lamp holders of the PCB holding plate. Flip up holding plate and loosen plug connection ST7.
- Put in safety devices in proper sequence.

1.4. Power Connection

The label on the power cord shows the voltage setting by the factory.

For other voltages set voltage required on transformers.

Green-yellow of the three-wire power cord must be connected to the ground according to the international safety code. The line cord is located in a box on the rear of cabinet. To pull out the line cord the steel cover has to be removed (4 screws). Put the cable through the respective hole in the cover and put the cover back afterwards.

Check main voltage before connecting!

After plugging in the phonograph turn on the switch located at the rear of the cabinet (fluorescent lights should now light up).

1.5. Title Strips and CD'S

When pressing the latch springs on the side, the complete title display (Fig. 3/1) can be pulled down.

Either by pressing the PUSH TO FLIP key - on the outside of the machine - or TAS 1 on the PCB, to the right of the title display - the flip chart is turned forward.

Clip the marked title strips into the title-strip holders.

Push service buttons (Fig. 1/15) each to the center, swing open magazine and equip with CD's. Observe the sequence of the magazine and title strip numbers.

Information: To take out the opened magazines push the service keys (Fig. 1/15) to the outside; take out magazines one after the other!

The CD's can be protected against falling out when transporting equipped magazines. For that put the plastic pipe of the lift axle as well as a second one from the enclosed package (Fig. 1/4) through the magazines and all CD's.

2. LAYOUT OF UNITS (see illustration on right-hand side)

- 1 Title display
- 2 Receiver for remote control
- 3 Display/Keyboard
- 4 Output transformer
- 5 Control unit
- 6 Coin mechanism
- 7 Central unit
- 8 Volume control
- 9 CD changer
- 10 Network
- 11 Connection unit
- 12 Junction plate
- 13 Output stage

2.1. SELECTOR and DISPLAY PANEL

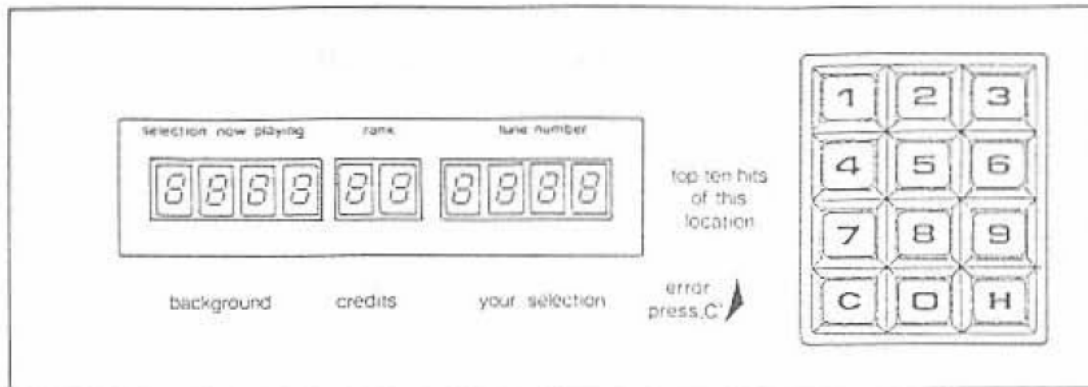

Display panel with displays 1, 2 and 3 as well as 12 button selector

Fig. 2

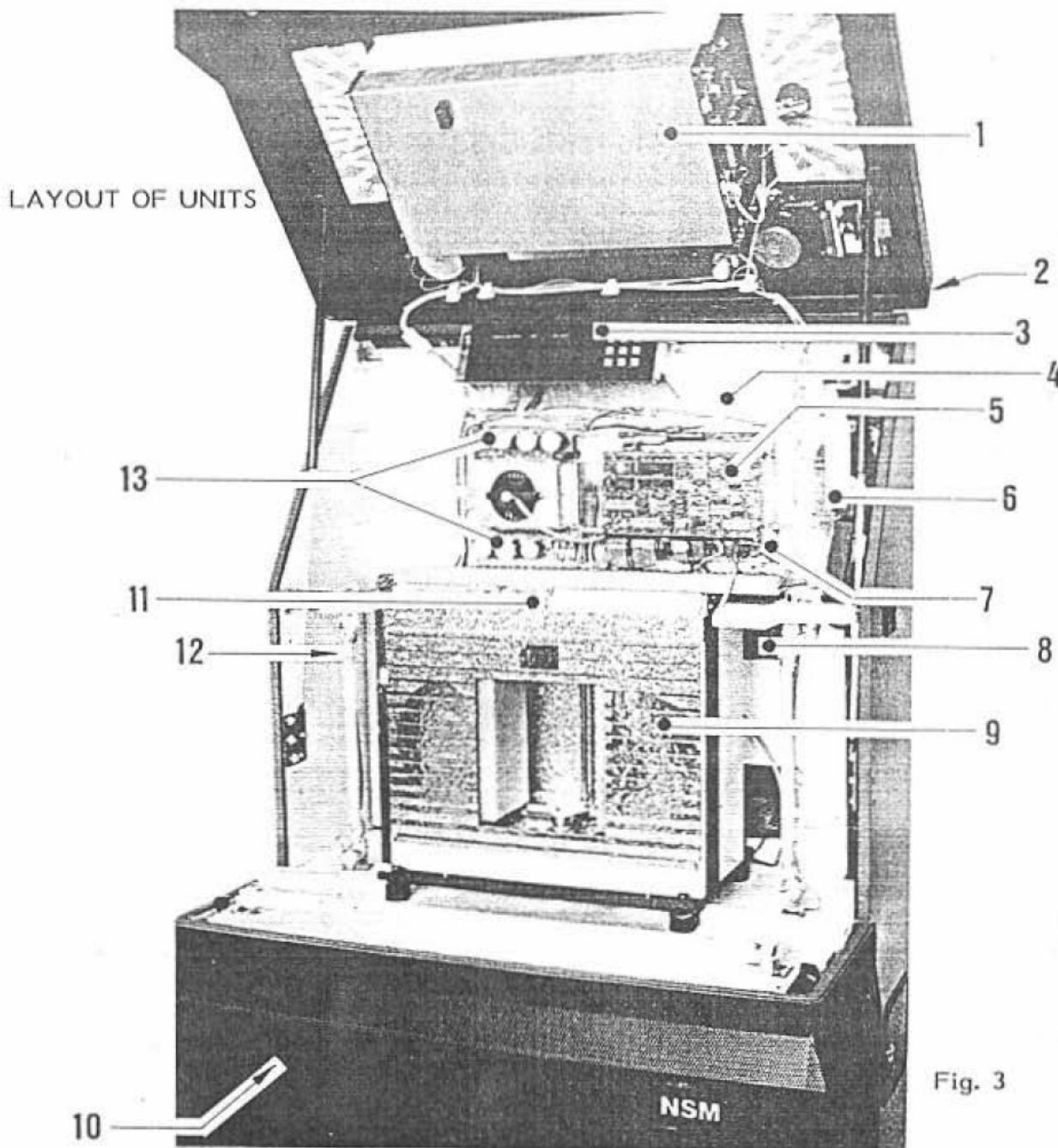

Fig. 3

3. SPECIFICATIONS

3.1. Electrical Data

Main voltage: 100-260 V (exchangeable), 50/60 Hz

Power consumption
at standaby 170 watts
at play 450 watts

3.2. Music Power

2 x 200 watts music power at 2 ohms

3.3. Fuses

Replace fuses only with those of same value!

3.4. Lighting

Lamps = 12 V/2 W/3 W
1 fluorescent lamp = 16 W
1 fluorescent lamp = 13 W
2 fluorescent lamps = 8 W

3.5. Credit / Cash Input

Maximum credit display is 99.
Price list adjustable individually or as per table.
Free credit adjustment/permanent credit key-operated switch
for free credits and background, elect.-mech. cash counter
(optional).

3.6. Keyboard

10 number keys 0-9
1 correction key "C"
1 hit-step key "H"

3.7. Displays

Display 1 with 4 seven-segment LED's
Display 2 with 2 seven-segment LED's
Display 3 with 4 seven-segment LED's
1 lamp display "10 top hits"
1 lamp display "background"
1 lamp display "credit"
1 lamp display "your selection"
1 lamp display "error, press key "C"

3.8. CD Changer

NSM CD changer for maximum 100 CD's, 5- or 3 inch disc player:
Philips CD-2-system with CDM-3-playing unit, servo panel for
control of CDM-3.

3.9. Loudspeakers

2 loudspeakers P 300 4 ohms
2 loudspeakers P 175 8 ohms
2 loudspeakers P 135 8 ohms
2 loudspeakers Skk 10 4 ohms

3.10. Special Features

Integrated microphone preamplifier and connection socket for microphone with paging switch.
Computer-controlled amplifier protection for overload (mismatch).

3.11. Dimensions

Height 56 inches
Width 38 inches
Depth 27 inches

4. LOUDSPEAKER CONNECTION

The ES-IV amplifier supplies an output of 2 x 200 watts music power at 2 ohms per channel.

The impedance of the cabinet loudspeakers is 5,5 ohms, therefore, the cabinet speakers use 2 x 70 watts music power from the amplifier - only one half of the available power.

Therefore, additional loudspeakers can be connected (Fig. 1).

However, in this case the additional loudspeakers connected can not have an impedance of less than 3 ohms because otherwise the amplifier would be "mismatched" and the overload protection would operate.

If loudspeakers with a higher impedance are connected (Fig. 2), a number of speakers can be connected parallel. In that case, a loudspeaker with a higher impedance would naturally be lower in volume.

The ▼ = polarity must be maintained because otherwise bass reproduction would nullify itself.

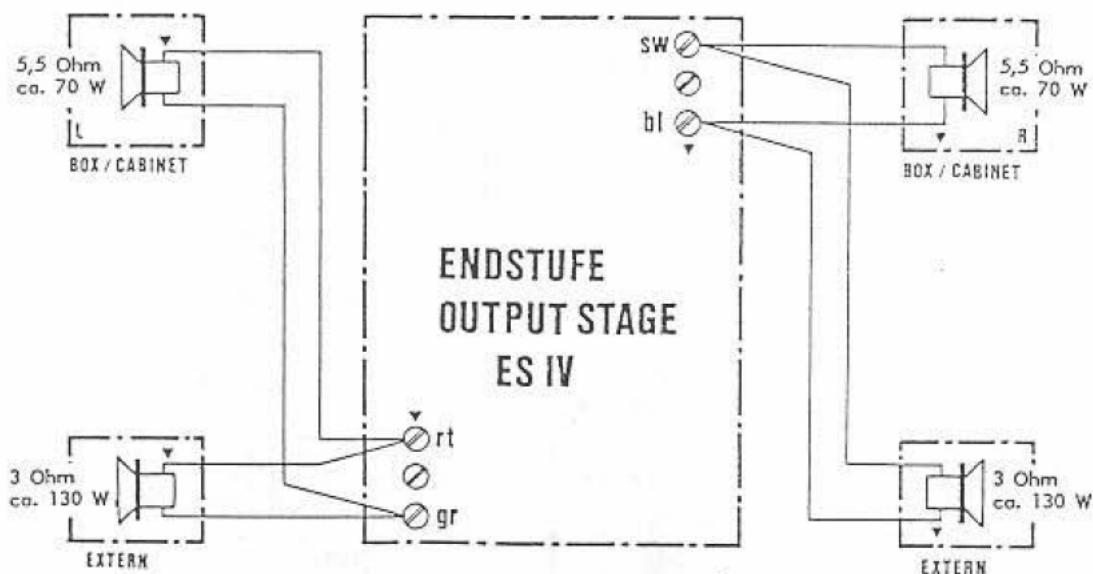

Fig. 1

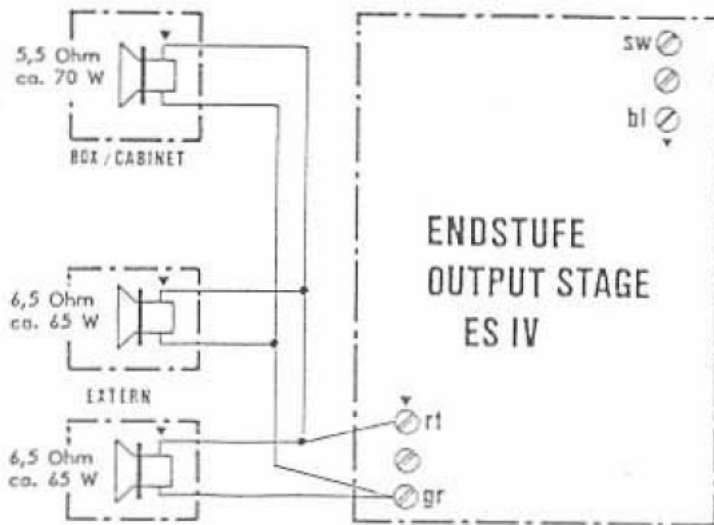

Fig. 2

Mono mode; sound system for separate rooms; see Fig. 3. If the volume is to be controlled independently from 2 rooms, both cabinet speakers can be connected to one channel. The loudspeaker for the other room can then be connected to the free channel. For that a jumper has to be soldered at DR 202 (see cut-out PCB central unit).

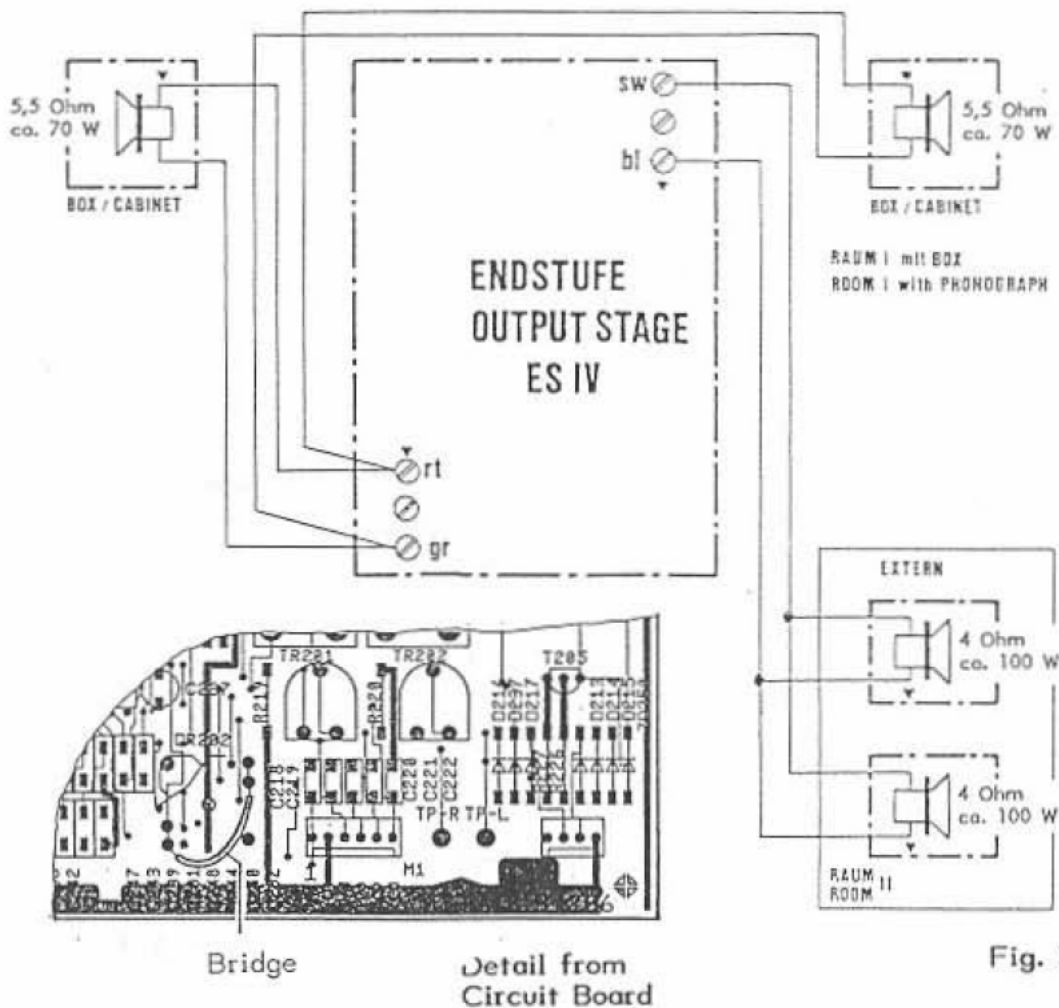

Fig. 3

Additional Loudspeakers and Separate Control

If even more speakers are to be connected whereby the total impedance drops below 2 ohms, an output transformer has to be used (see schematics "loudspeaker connection" and unit description "OUTPUT TRANSFORMER"). Cabinet speakers (Fig. 4) in serial connection result in lower volume!

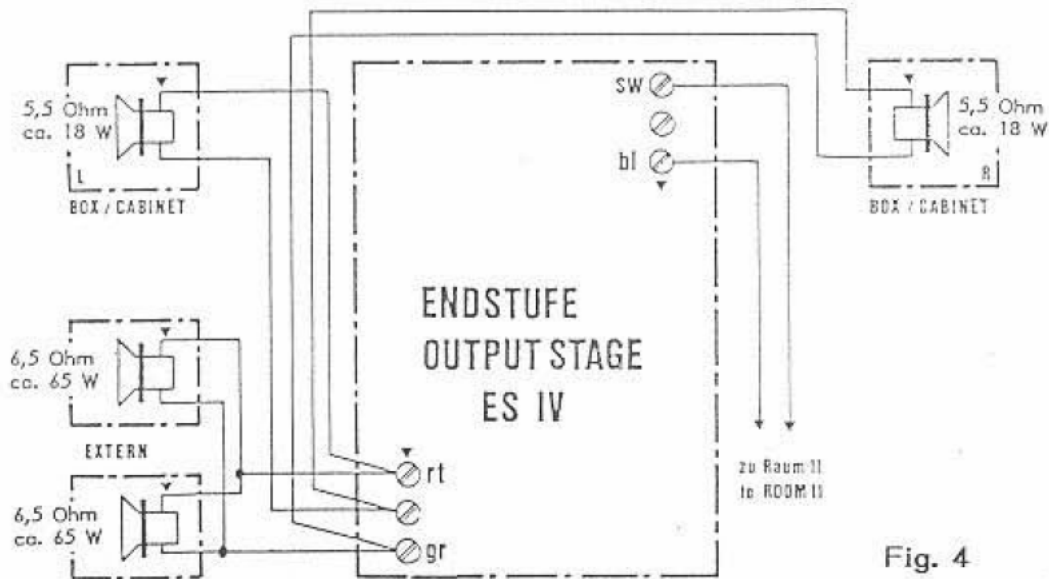

Fig. 4

Lautsprecher - Kombination SPEAKER COMBINATION

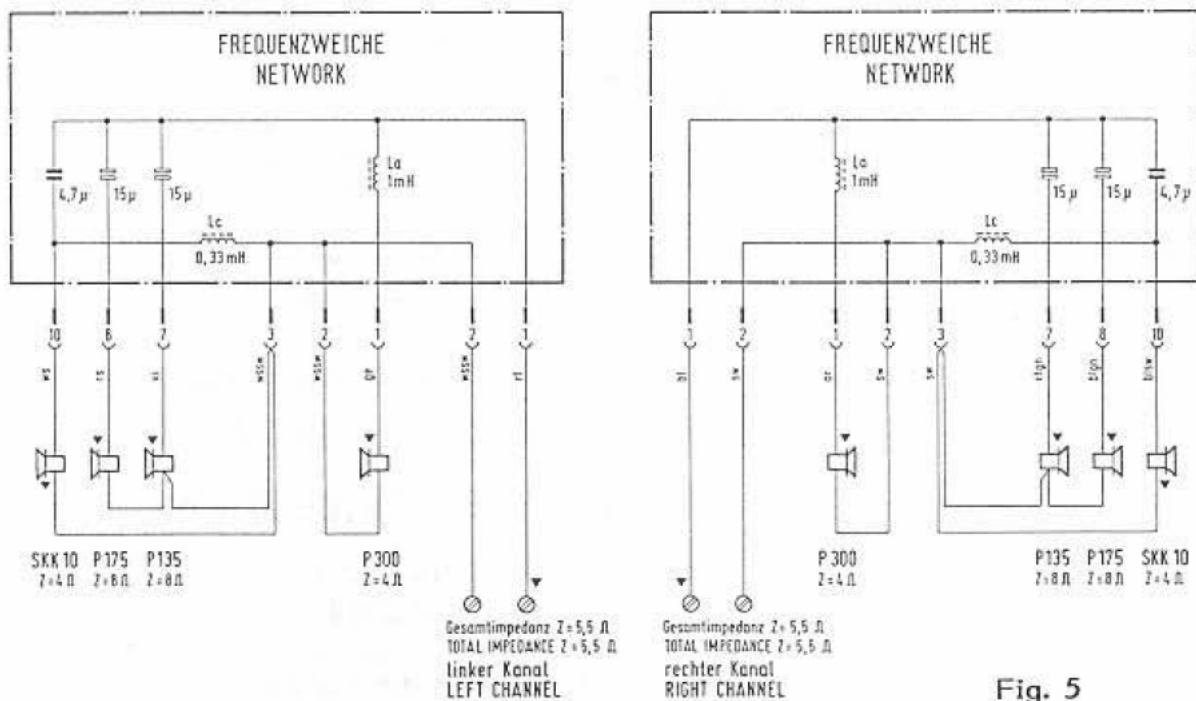
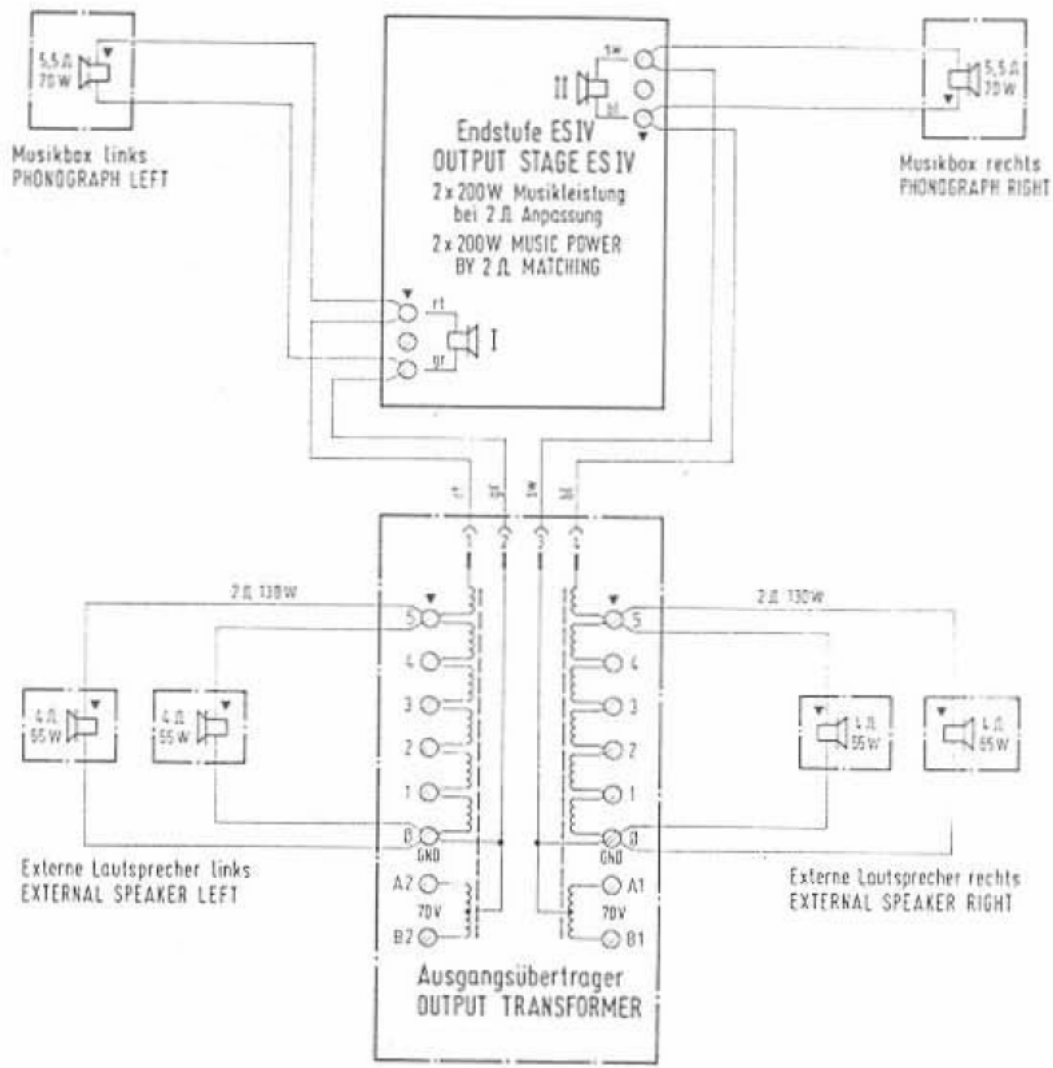
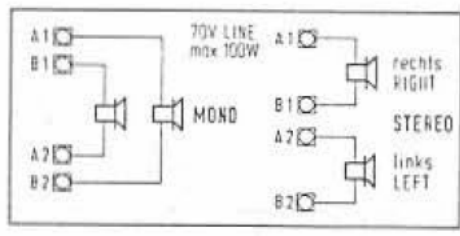

Fig. 5

Verstärker oder Ausgangsübertrager
AMPLIFIER OR OUTPUT TRANSFORMER



Anschlußschema für Ausgangsübertrager
 CONNECTION DIAGRAM FOR OUTPUT TRANSFORMER



Klemme TERMINAL POSITION	Lautsprecher SPEAKER			
	2,5 Ω	4 Ω	8 Ω	16 Ω
0 - 5	100 W	70 W	45 W	22 W
0 - 4	48 W	30 W	16 W	8 W
0 - 3	24 W	15 W	8 W	4 W
0 - 2	12 W	7,5 W	4 W	2 W
0 - 1	3 W	1,8 W	1 W	0,5 W

ÄNDERUNGEN IM SINNE DES TECH. FÖRHSCHRITES VORBEHALTEN,
 JEDOCH KEINE NACHBUSTPFLECHT!
 SUBJECT TO TECHNICAL MODIFICATION WITHOUT OBLIGATION
 TO MODIFY EQUIPMENT ALREADY DELIVERED!

MUSIKAUTOMATEN
 PHONOGRAPHS **ES IV - CD** TECHNOLOGY

Lautsprecheranschluß
 SPEAKER CONNECTION

Anschluß für max. Ausgangsleistung
 CONNECTION FOR MAX. POWER OUTPUT

Dat.	Ver.	Druck.	Verf.
26.01.89	Braun	U.

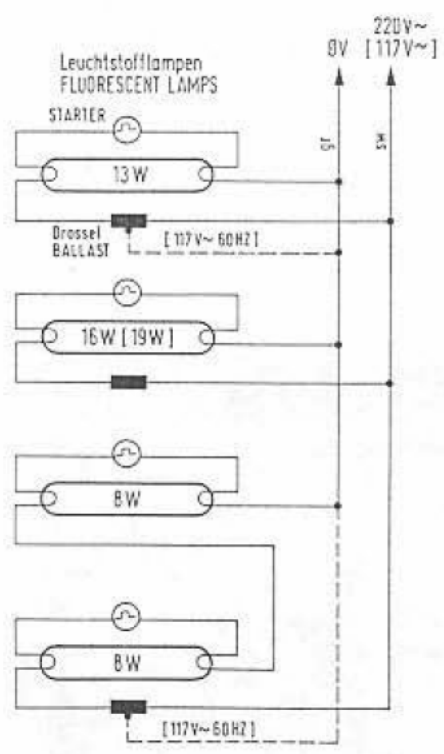
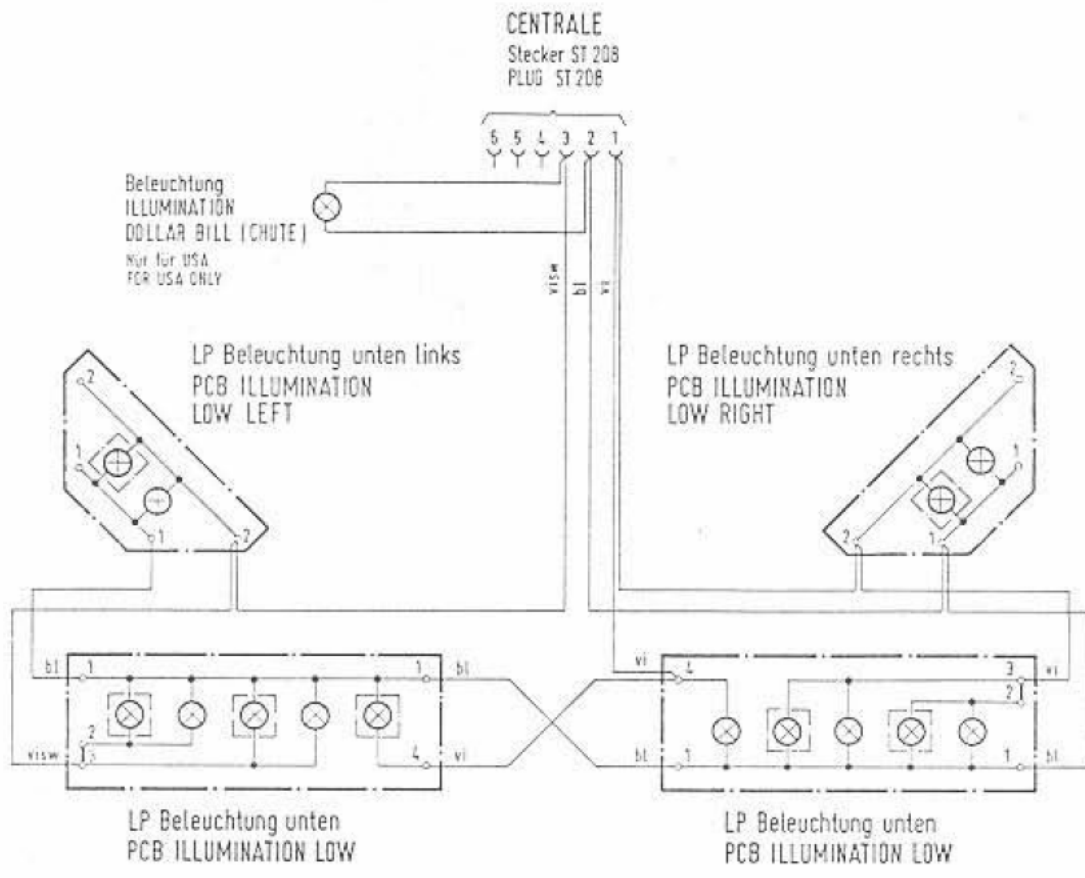

gerasterte Bauteile sind nicht eingebaut!
DOTTED COMPONENTS ARE NOT INSTALLED!

ÄNDERUNGEN IM SINNE DES TECHN. FORTSCHRITTES VORBEHALTEN,
JEDOCHE KEINE NACHRÜSTPFLICHT!
SUBJECT TO TECHNICAL MODIFICATION WITHOUT OBLIGATION
TO MODIFY EQUIPMENT ALREADY DELIVERED!



MUSIKAUTOMATEN
PHONOGRAPHS

ES IV - CD TECHNOLOGY

Schaltbild WIRING DIAGRAM
Beleuchtung ILLUMINATION

CD GALAXY

Dat. 17.01.89	Gez. Braun	Stamps Zehnd	Gepr. Maunz
---------------	------------	--------------	-------------

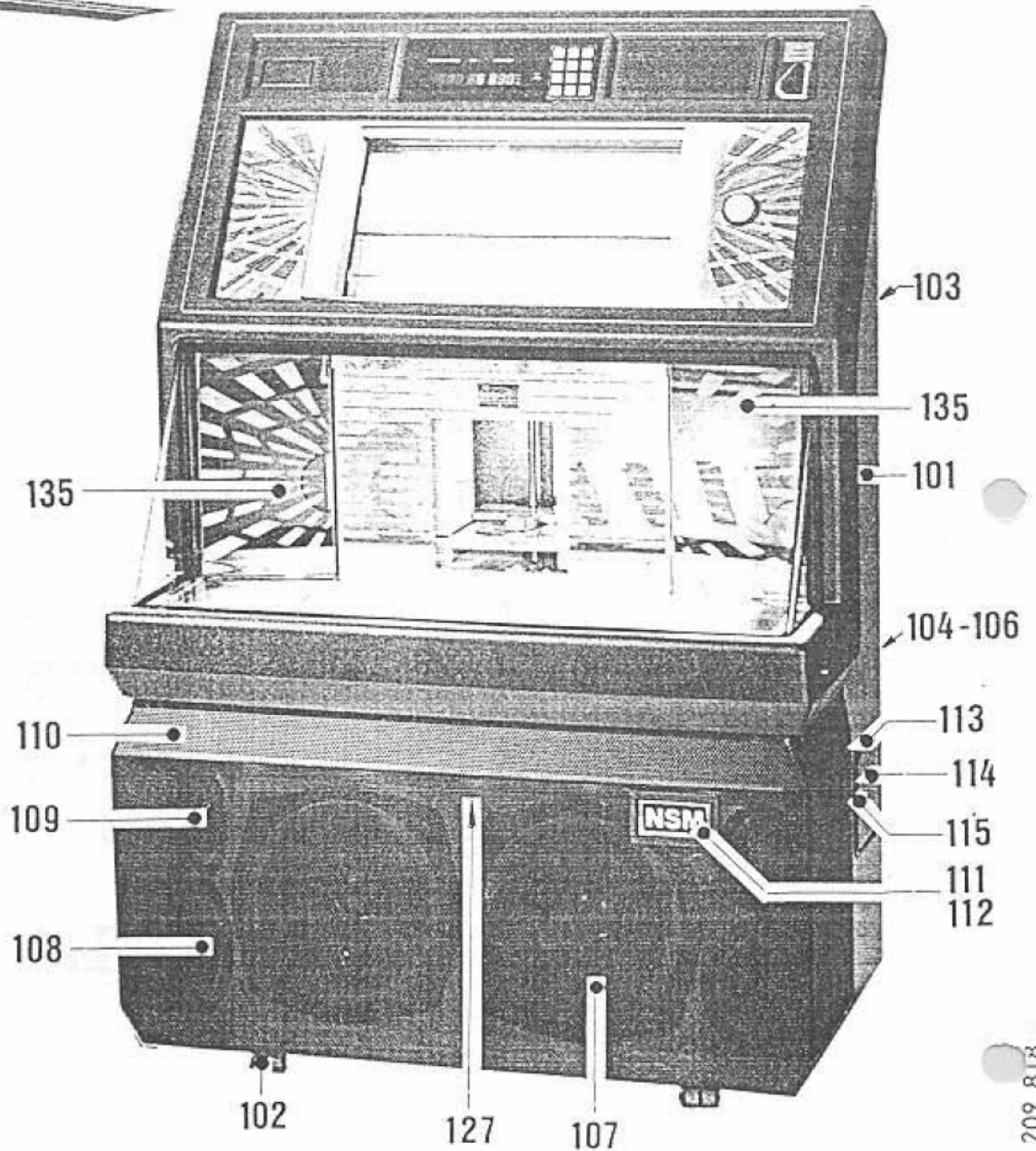
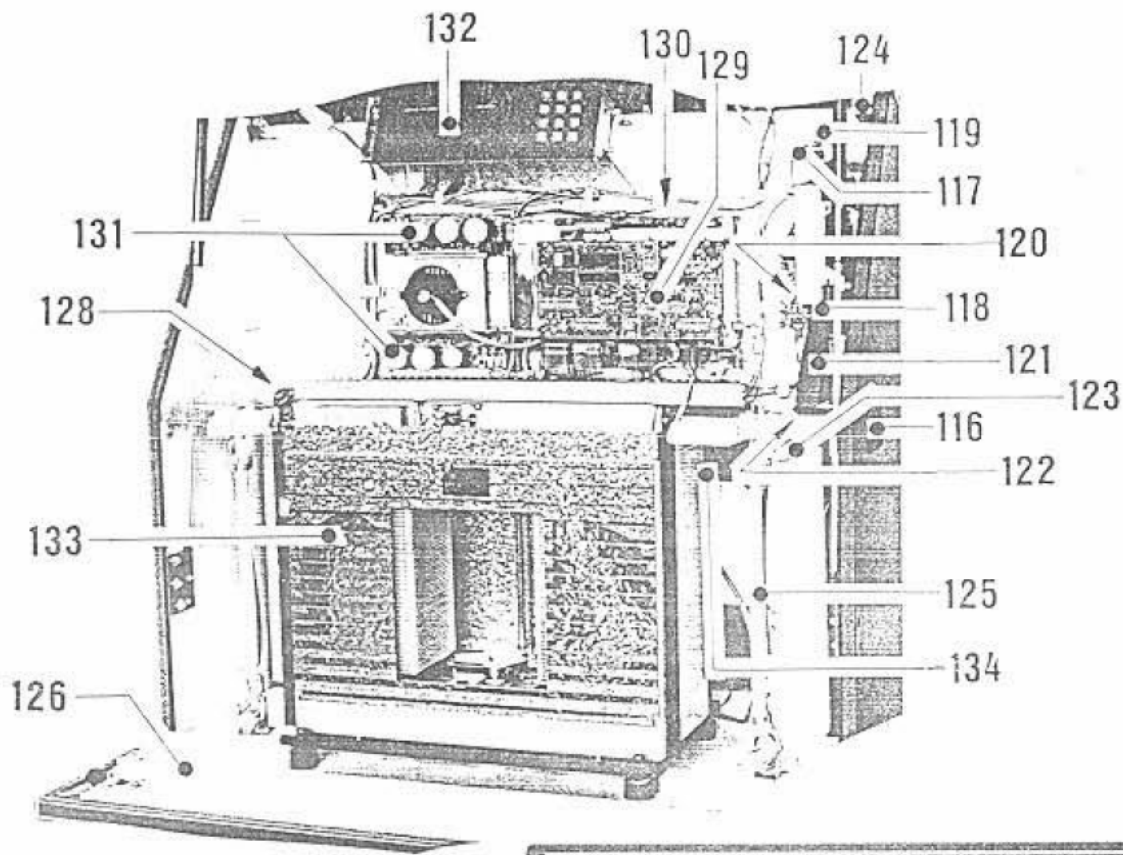

SPARE PARTS LIST

POS.	PART-No	DESCRIPTION	DATA	QTY
		<u>PHONOGRAPH >CD GALAXY<</u>		
101	203 784	CABINET		1
102	217 506	CASTERS		4
103	170 852	HANDLE		2
104	173 968	TRANSFORMER PLATE	(in REAR WALL)	1
	217 772	HINGE		1
105	223 418	TRANSFORMER		1
106	223 417	TRANSFORMER	(CD-PLAYER)	1
	225 907	TRANSFORMER-FUSE		1
107	224 240	LOUDSPEAKER	P 300 4 OHM	2
	173 970	DECOR RING		2
108	224 241	LOUDSPEAKER	P 175 8 OHM	2
109	224 242	LOUDSPRAKER	P 135 8 OHM	2
	173 971	DECOR RING		2
110	172 452	SPEAKER GRILL		1
	250 241	PROFILE		4
	250 242	PROFILE		4
111	172 531	FRAME		1
112	172 533	GLASS, PRINTED	NSM-EMBLEM	1
	172 519	NETWORK		2
113	023 681	CASH-BOX, FRAME		1
114	042 108	CASH-BOX, DOOR		1
115	207 008	CASH-BOX, LOCK	Typ 447-04-01	1
	207 496	CASH BAG		1
116	103 378	COIN RETURN CUP		1
	102 495	COIN LID		1
	172 474	COVER		1
117	172 415	COIN RETURN LEVER, STAMP.		1
118	170 031	COIN CHUTE, ASSY		1
119	172 417	COIN TUBE	(COIN INSERT)	1
120	171 905	COIN FUNNEL		1
121	172 545	COIN TUBE	(COIN CHUTE)	1
122	172 546	COIN TUBE	(CASH-BOX)	1
123	217 850	ZYL. LOCK		1
	222 366	MICRO SWITCH	KEY SWITCH	1
124	172 724	SWITCH PLATE		1
	222 509	PUSH BUTTON SWITCH	CABINET SWITCH	1
	225 756	SOCKET	1853 BF	1
	225 757	SOCKET with STARTER SOCKET	1853 AF	1
125	226 038	FLUORESCENT LAMP	8 W	2
126	226 073	FLUORESCENT LAMP	16 W	1
	224 064	BALLAST	KX 16 D 50 Hz	1
	224 188	BALLAST	KX 13 D 50 Hz	2
	225 040	STARTER	S 10	1
	225 343	STARTER	S 2	2

SPARE PARTS LIST

POS.	PART-No	DESCRIPTION	DTRA	QTY
127	206 328	CIRCUIT BOARD-LIGHTING, LOWER		2
	206 329	CIRCUIT BOARD-LIGHTING, LOWER	RIGHT and LEFT	2
	225 533	LAMP SOCKET		7
	226 049	LAMP	12 V 2 W	7
128	171 725	JUNCTION PLATE, ASSY	50 Hz	1
	171 726	JUNCTION PLATE, ASSY	60 Hz	
129	173 663	CIRCUIT BOARD-CONTR. UNIT, ASSY		1
130	173 667	CIRCUIT BOARD-CENTR. UNIT, ASSY	50/60 Hz	1
131	171 701	OUTPUT STAGE	50 Hz	1
	171 702	OUTPUT STAGE	60 Hz	
132	173 664	CIRCUIT BOARD-DISPLAY CD		1
133	173 470	CD-CHANGER 100, STANDARD	without design parts	1
	173 938	FRONT TRIMPLATE	magazines	1
	173 920	SIDE TRIMPLATE	back cover	2
	172 431	OUTPUT TRANS. with HARNESS		1
134	170 212	VOLUME CONTROL, ASSY	in CABINET MOUN.	1
	171 808	IR-REMOTE CONTROL, ASSY		1
	217 817	SENDER		1
	173 178	RECEIVER		1
	171 883	CONNECTING CABLE for RECEIVER	1,5 metre	1
	170 459	CONNECTING CABLE for RECEIVER	5,0 metre	1
	171 743	REMOTE CONTROL	w. 5 metre CABLE	1
	172 077	REMOTE CONTROL	w. 20 metre CABLE	1
	224 223	MICROFON		1
	171 880	MICROFON CABLE	10 metre	1
	172 187	MICROFON CABLE	25 metre	1
	173 985	CONNECTING UNIT, ASSY	for WALLBOX	1
	172 025	TAPE RECORDER CONNec. CABLE		1
	114 772	RECORDING DEVICE SYSTEM, ASSY		1
		173 348	CASH COUNTER, ASSY	
135	204 863	SIDE GLASS		2

SPARE PARTS LIST

POS.	PART-No	DESCRIPTION	DATA	QTY
		<u>CABLE HARNESS</u>		
	172 506	DISPLAY (1100 lg)	10 PRONGS	1
	172 508	CENTRAL UNIT -- OUTPUT STAGE (700 lg)	10 PRONGS	2
	172 510	LOUDSPEAKER		1
	172 511	CENTRAL UNIT -- LINE TRANS.		1
	173 266	LIGHTING		1
	171 782	CENTRAL UNIT -- CONTROL UNIT (120 lg)	15 PRONGS	1
	171 783	CENTRAL UNIT -- CONTROL UNIT (120 lg)	12 PRONGS	1
	173 955	FLUORESCENT LAMP 13 W		1
	173 956	FLUORESCENT LAMP 8 W		1
	173 958	KEY and CABINET SWITCH		1
	173 164	CENTRAL -- CD PLAYER		1
	151 626	CONTROL UNIT -- CD PLAYER		1
	173 963	TRANSFORMER -- CD PLAYER		1
	173 964	CENTRAL -- PROGRAM LID CON.		1
	173 966	CD-AUDIO		1

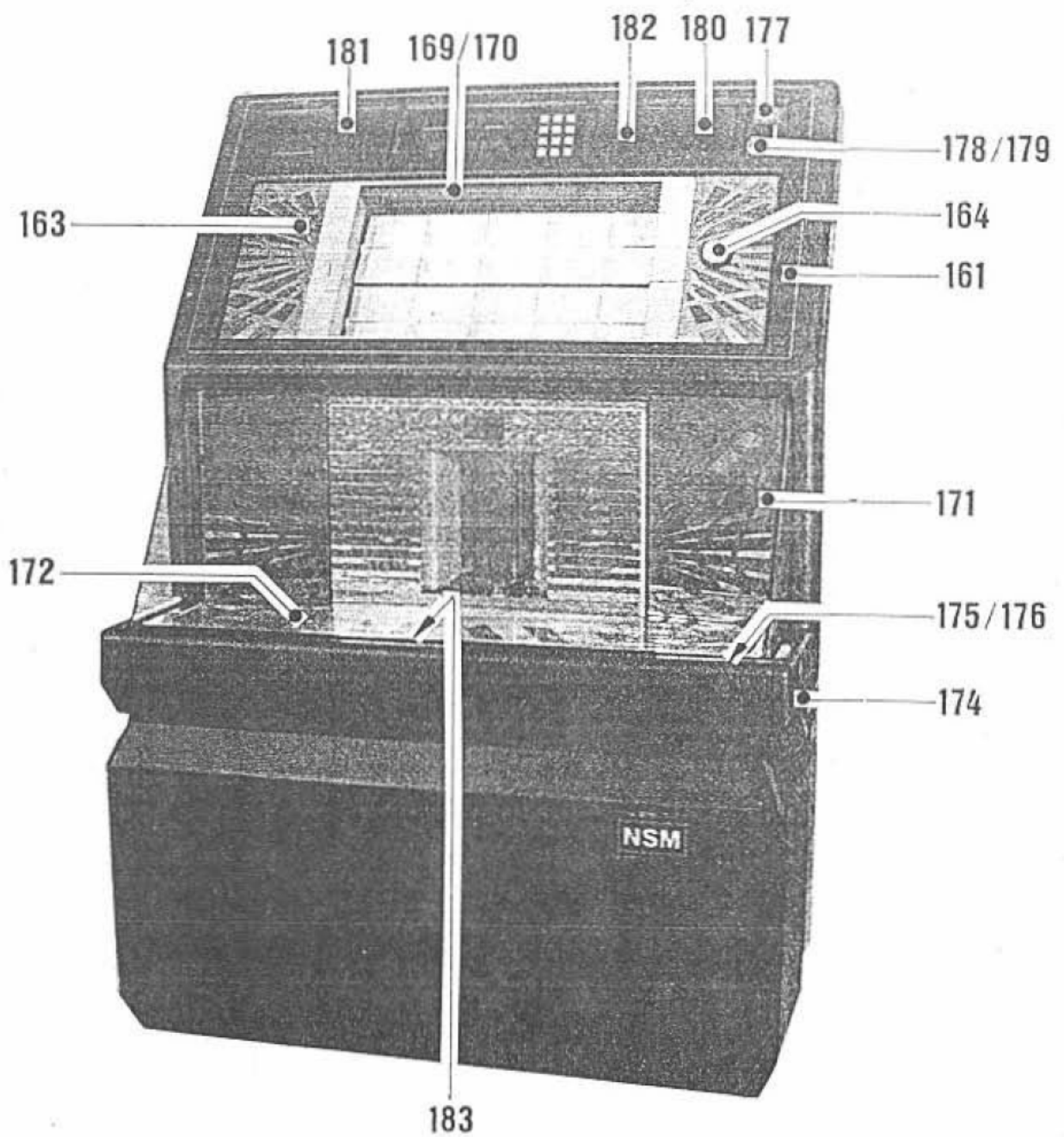
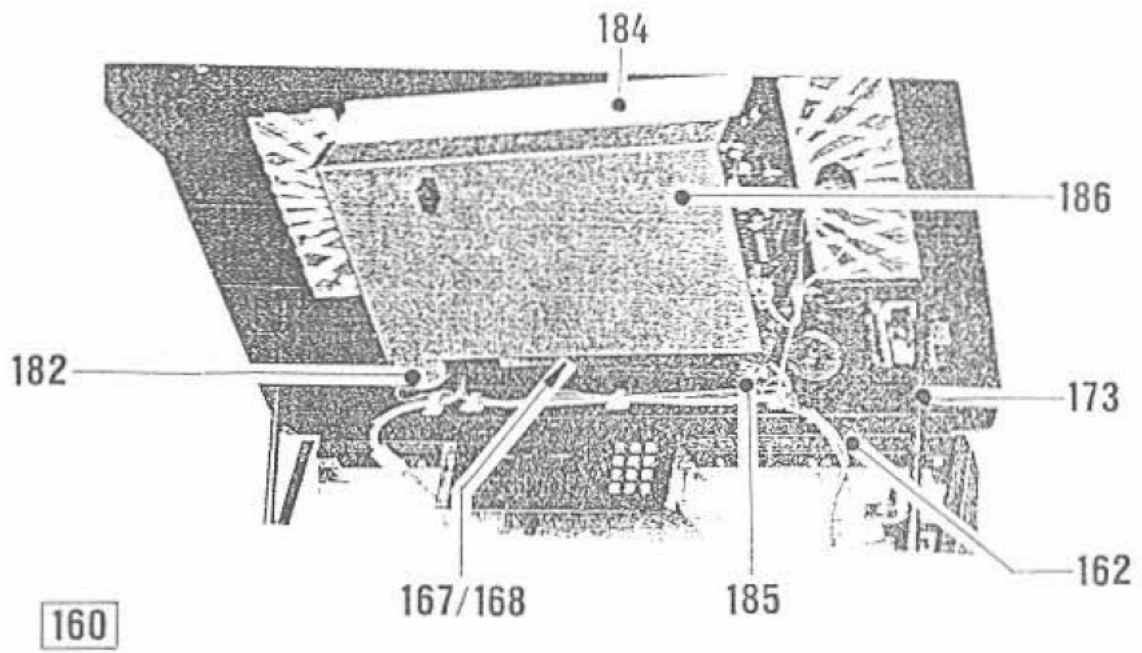

SPARE PARTS LIST

POS.	PART-No	DESCRIPTION	DATA	QTY
160		<u>COVER</u>		1
161	172 428	COVER, PRE-MOUNTED		1
162	206 297	HINGE		1
163	204 861	GLASS, UPPER		1
	217 507	RUBBER PROFILE	2x800 lg/2x275 lg	4
164	173 982	BUTTON ROUND, ASSY	PUSH TO FLIP	1
	115 010	COVER		1
165	172 391	HOLDING BAR		1
166	173 767	HOLDING BAR, UPPER		1
167	173 771	BACKPLATE		1
168	173 770	TRIMPLATE		1
169	173 769	SIGHT TRIMPLATE		1
170	209 786	LABEL	SIDE PIECE, interior	2
171	204 868	FRONT GLASS		1
	206 333	RUBBER PROFILE	1595 long	1
	206 334	RUBBER PROFILE	1300 long	1
172	204 862	BOTTOM TRIMPLATE		1
173	206 320	PISTON ROD	ATTENTION! Please note type.	2
174	217 814	ZYL. LOCK		1
	217 992	SPARE KEY		1
175	172 447	CLOSED BAR		1
176	171 616	CLOSED NOSE		2
177	172 502	GLASS, PRINTED		1
178	171 892	COIN INSERT		1
179	171 662	COIN REJECT		1
180	172 376	BACKPLATE, RIGHT		1
	209 065	SPEAKER WEB, RIGHT		1
181	172 377	BACKPLATE, LEFT		1
	209 066	SPEAKER WEB, LEFT		1
182	224 233	LOUDSPEAKER	SKK 10	2
183	226 075	FLUORESCENT	13 W	1
184	173 973	TRIMPLATTE, LOWER		1
185	225 343	STARTER	S 2 220-240 V	1
186	173 416	TITLE DRUM, ASSY		1
	173 982	<u>BUTTON, ASSY</u>	<u>PUSH TO FLIP</u>	
	115 009	HOUSING, round		1
	173 909	BUTTON, round	violet	1
	173 907	BUTTON INSERTION, PRINTED	PUSH TO FLIP	1
	205 770	PRESSURE SPRING		2
	114 638	ADAPTER		1
	222 515	MICRO SWITCH		1
	225 587	LAMP SOCKET		1
	226 049	LAMP	12 V 2 W	1
	173 965	CABLE HARNESS		1

OPERATING INSTRUCTIONS FOR NSM-PHONOGRAPHS

ES IV-CD TECHNOLOGY

to

Technical Information, Assy

174 903	SILVER CITY
174 831	SILVER SKY
174 486	FASCINATION
175 274	SOUNDMASTER
175 040	FIREBIRD/COUNTRY
176 046	THE PERFORMER "GRAND"

NSM
Aktiengesellschaft
Saarlandstraße 240
6530 Bingen am Rhein

2

Page 201-213

INDEX

- 1 PLAYING SEQUENCE
 - 1.1 Operation after switching on
 - 1.2 Standby
 - 1.3 Credits
 - 1.4 Selection
 - 1.5 Play mode

- 2 ADJUSTMENTS WITH REMOTE CONTROL
 - 2.1 Volume controls
 - 2.2 Muting
 - 2.3 Free credits
 - 2.4 Background music
 - 2.5 Key switch

- 3 SERVICE OPERATION - short program for price settings

- 4 CD change / cash collection

SELECTOR and DISPLAY PANEL



1 PLAYING SEQUENCE

The functional sequence, starting with "power on", standby credit, selection and playing of selected title to the rest position is described below.

The technical assembly and the working together of the components can be seen in the "electronic schematics". Compare the descriptions with the illustration of the display / keyboard above.

1.1 Operation after Switching on

Immediately after switch-on the memory components -on the CONTROL UNIT- and all preprogrammed values are checked.

Display 1 shows then for 2 sec. the program index

If an error is found during checking, error display Er xx is then shown for 2 sec.

With Er 31 (unverified memory contents) and Er 40 (price settings incorrect) Display 1 with Pxx shows the correct program step which needs to be reprogrammed. See description of service programs.

With other Er-displays, even during operation, proceed according to the instructions in "Trouble Shooting".

1.2 Standby

Hit display:

The microprocessor of the CONTROL UNIT figures out of the 30 titles just played before the ones played most.

On Display 3 the title numbers of the 10 most popular titles, whose rankings (1-10) are shown on Display 2, are changed in intervals of 2 sec. Also "10 top hits" lights up.

When pushing "H", the hit display can be stopped for 16 sec; every press of the key causes an advance to the next hit.

Note: When the popularity counters are erased (program step P 10), the hit parade is erased, too. In that case "0" appears for ranking until records are played again.

Random Play:

In program step P24 a time interval can be set for random tune playing.

Conditions for a random title to be played:

- Phonograph in standby mode
- No credit available
- Microphone switch not being used
- No muting
- Set time is expired

1.3 Credits (not for HIDE-AWAY)

See unit description "Coin and Bill Validation".

After insertion of a coin the "hit display" is interrupted, lamp "10 top hits" goes off and "credit" and "your selection" light up. Display 2 shows the number of credits.

For every selection credit is deducted.

If not enough credits are available for the selection, "credit" lamp flashes.

If no more coins are inserted within 16 sec. or no selector key is pressed, the mode changes to "hit display".

Free-credit switch (add. key), below the mechanical coin acceptor or on the adapter PCB with electronic coin validators, is only possible when the cabinet lid is open and the cabinet interlock switch is in service position (press add. button once = 1 credit). These credits are not registered statistically.

Starting with program index 0003 selections can be made without credits after pulling out the cabinet switch and going back to the regular program (2 x "C" key).

Attention! The machine is furnished with an interlock switch which must be manually set in service position (pull out). The switch resets automatically when closing the lid.

Note: Credits remain stored during "power off/on".

If the computer detects no activity on the phonograph within 1 hour, the stored credit is cancelled.

1.4 Selection

Title Selection: The four-digit number of the desired title has to be entered (2 digits each for disc and track). "Credit" and "your selection" light up. The selection can be corrected by pressing "C" up to 2 sec. after pressing the 4th digit.

Album Selection: When entering Track 00, all titles of a CD are automatically played (i.e. 0100 = all titles of Disc 01).

The number of credits which are deducted when selecting an album can be programmed in step P46.

When programming "0", album selection is blocked.

With open cabinet switch (interlock lever pulled out) no credit is deducted when selecting.

If the entry is incorrect, e.g. higher than the programmed number of CD tracks which can be selected or an unallowed selection of albums, "error" flashes. In that case, press "C" and repeat the selection.

One credit is deducted for each selection of a title. With album selections credits are deducted as per the programming in program step P46. If there is not enough credit available, "credit" lamp flashes.

16 sec. after selection "hit display" is switched on automatically again.

Note: If a background or random title is playing during selection, the volume is fading and the selected tune is being played.

When selecting a higher title number than recorded on the CD, the first title (track) of the CD will be played automatically.

1.5 Play Mode

After selection the microprocessor of the CONTROL UNIT moves the pickup of the CD changer to the selected CD and pulls it with its holder out of the magazine into the pickup. The pickup brings the CD to the disc player where it is then played.

Just before play the number of the title is shown on Display 1 ("selection now playing"). After the disc is played, the display is erased and the CD is transported back to its magazine space.

Note: If an error occurs with the CD changer or the player, "Er 7x" or "Er 6x" appears for 2 sec. In that case proceed according to the description in "Trouble Shooting".

Limiting Playing Time for a Title (Track)

In Service Program P30 the time that a title is to be played maximum can be set in minutes.

After expiration of this time the volume for that title is fading and then muted.

When setting "0" (default), there is no limit in playing time.

Sequence of Tunes Playing

In Service Program P31 one can set in which sequence the selected titles are played.

Settings: 0 = in sequence of selection (FIFO)
 1 = in numerically increasing sequence
 2 = random sequence

Limit of Playing Titles on the Same CD

One can set in Service Program P32 how many titles can be played consecutively on the same CD.

With 0 (default) there is no limit.

Attention!

When playing a test compact disc, the description that comes with the test disc is to be exactly adhered to. By any means, it is to be avoided to give sine signals with peak signal "0dB" at full volume level to the loudspeakers for more than 1 sec.

But also other unfiltered noises and high-frequency signals (which are only used for measuring purposes) can damage the amplifier and loudspeakers at full volume.

When checking channel separation, this test can only be done with a frequency of 1 KHz.

1.6 Title display

By pushing the keys respectively title holders are moved into the corresponding direction. Upon each key operation two new CD-covers including titlestrips are shown. In case of a limitation of selectable CD's via service step P22 only the corresponding title holders are shown.

Note: A problem with the title display will initiate error code "Er 9x". Following instructions in paragraph 14 (trouble shooting).

2 ADJUSTMENTS WITH REMOTE CONTROL

The phonograph can optionally be equipped with cable-type remote control or infra-red remote control. All functions and the operation of both models are identical. Therefore, this description is valid for both of them.

The button-control box attached to the rear of the cabinet allows common control of both channels "+" or "-" and "REJECT".

Information about the functions of different controls is presented in the unit description "Remote Control".

Note: The button volume control is not present with wallboxes such as the "CD FIRE" or the "CD HIDE AWAY".

2.1 Volume Controls

We differentiate between two volumes:

- 1.) The normal volume of selected titles and random play titles
- 2.) The background volume of background titles

For selected titles and random titles or with microphone and tape mode the corresponding volume is adjustable; background volume only with background mode:

Key "I" for the left channel; Key "II" for the right channel; "+" = louder, "-" = quieter. When pushing center key (I+II), the channels are regulated together. If they were differently set, they are first "balanced" and regulated together.

When no selection is taking place, the volume for the channels are shown in Display 3 during the adjustment in steps of "1" to "31".

At "muting" function "OFF" appears in Display 1; no more titles will be played until MUTING is cancelled.

The volume set at the end is stored during "power off".

The maximum possible volume for normal and background mode can be limited in service program P28 in steps of "1" to "31".

Note: To protect the amplifiers a check is made whether an overload occurs due to mismatching in 250 ms cycles.

Upon recognition of an error the volume of the corresponding channel is reduced step by step automatically by the computer until a non-critical point is reached.

2.2 Muting

The volume of both channels can be set at "0" by pressing the MUTING key; "OFF" appears on Display 1. Re-pressing of the MUTING key a VOLUME "+" key causes the system to switch back to the previously set volume for both channels.

Note: With display "OFF" no more records are played until MUTING is switched off.

2.3 Free Credits

With an "open" key switch free credits programmed in program step P23 can be called up. The following free credits are possible depending upon the settings in step P23:

- 1.) Number of set free credits can be called up individually step by step.
- 2.) Unlimited free credits can be called up individually step by step.
- 3.) Permanent credit when pressing key "FREE CREDIT" for the first time (credit display "99"). When key "FREE CREDIT" is pressed again, permanent credit is blocked.

2.4 Background Music

With an "open" key switch the background mode can be switched on with the BACKGROUND key. "Background playing" lights up.

When pressing this key again, the background mode is switched off. In the background mode "random" records are played from the upper area of the magazine. The area can be set in program step P25.

The records are played at a "specific" background volume which can be changed as desired during playing cycle from "0" up to maximum volume set in program step P28.

A "normal record", selected while background music is playing, interrupts the background disc and the selected tune is played at "normal volume".

2.5 Key Switch

A key switch at the side wall serves as protection against unauthorized calling up of free credits and switching on the background mode. When the key switch is "locked", settings from the remote control are disregarded. Key switch "open" permits programmed free credits to be called up and the background mode to be switched on.

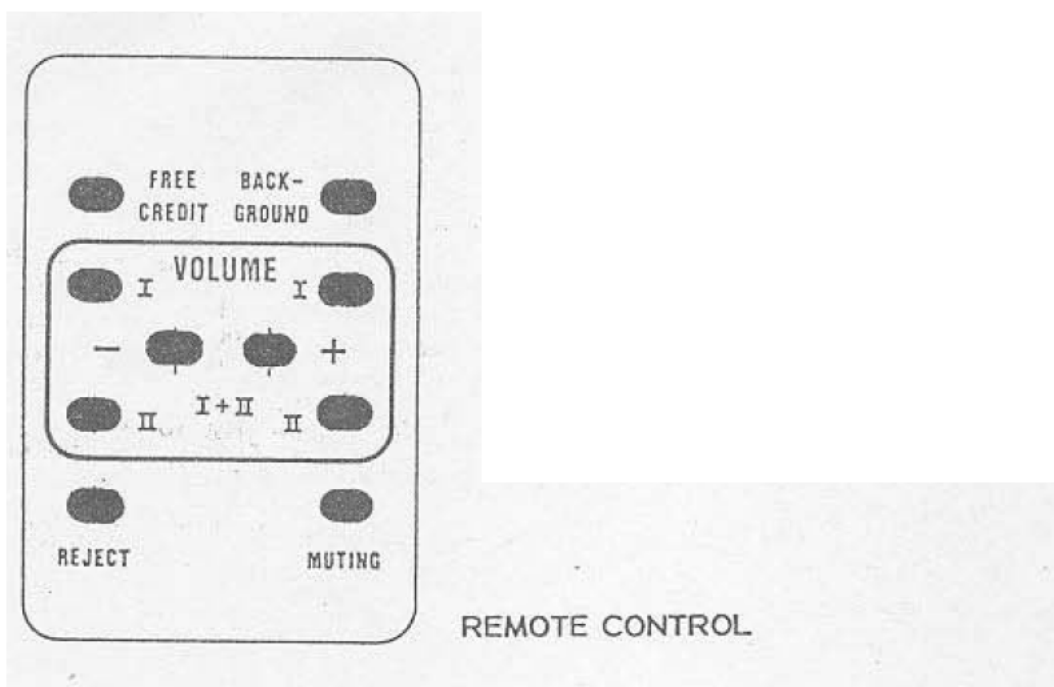

3 Service Operation -Short Program for 'Pice Settings-

This description is a summary of a section of the service program.
A detailed description and the corresponding tables are contained in
chapter 1.3 "Price Settings" and 1.4 "Monetary Value Settings".

Practical example for setting the "plays per monetary unit" and the
"monetary unit settings":

1 play = 30 p	1 play = 2x25 c
2 plays = 50 p	2 plays = 4x25 c
5 plays = 1 £	

Setting the price able (plays/monetary unit):

Programming Information	Operation	Displays		
		1	2	3
Switch-over from play mode to service mode	pull out plunger	P01		xxx
	Press key(s)		SP:	GW:
Select a program step	"C"	P		
Direct selection of program step, Display of previous setting in P41.	"41", "H".	P41	xx	xxx
New setting in P41 "1 play/30 p".	"01", "02", "H".	P41	01	030
Advance to next program step, Display of previous setting in P42.	"H"	P42	xx	xxx
New setting in P42 "2 plays/50p".	"02", "050", "H".	P42	02	050
Advance to next program step, Display of previous setting in P43.	"H"	P43	xx	xxx
New setting in P43 "5 plays/1 £".	"05", "100", "H".	P43	05	100
Advance to next program step, Display of previous setting in P44.	"H"	P44	xx	xxx
For only 3 classes setting "00 000".	"00", "000", "H".	P44	00	000
Advance to next program step, Display of previous setting in P45.	"H"	P45	xx	xxx
For only 3 price classes setting "00 000"	"00", "000", "H".	P45	00	000

Caution! Press "C" key in the event of incorrect programming or when display flashes.

Press "C" key twice or close hood to return to standard program (play mode).

Monetary Value Settings:

The individual coin channels must be programmed for the associated monetary values in the corresponding program steps: Channel 1 for 20 pence in program step P51, channel 2 for 50 pence in program step P52, channel 3 for 10 pence in program step P53. Channel 4 (P54) and channel 5 (P55) are not used; both must be programmed with the monetary value "0"!

Checking the monetary value settings: Select a program step between P50 and P55 (see description under "setting price table"). After inserting a certain coin the channel associated with the coin is displayed, e.g. 50 pence in channel 2: Display P52 050.

Changing the monetary settings: As an example, the 20 pence slot (channel 1) is not to be used: First enter program step P51 as described in point 1. In the coin acceptor or on the adapter PCB of electronic coin validators the respective channel has to be blocked also so that these coins drop into the coin return.

Programming information	Press keys	Displays		
		1	2	3
Direct selection of program step, Display of previous setting in P51.	See text.	P51		xxx
New setting; no coin conversion	"000", "H".	P51		000

If the standard setting according to the table is to be used thereafter, first switch on program step P50 (as described previously).

Ready for standard setting P50 through P55	See text.	P50		
Program standard table 1.	"1", "H".	P50		1

Press "C" key twice or close cabinet hood and return to standard program (play mode).

4 CD CHANGE / CASH COLLECTION

- Open machine and activate cabinet switch (pull out plunger) to enter into service mode. Display 3 automatically shows the least played CD.
- By pressing "1" successively, the next best CD is shown each time.
- Unlock magazine, swing out; pull out the corresponding CD holders to change CD's. After changing push back CD holders until they lock in.
- Change corresponding title cards, unlock flip-chart unit and flap down. Get desired program tables in position with the button on the PCB of the right-hand side of the unit.
- Read counters:
 - P03 = Cash total
 - P04 = Counter for plays
 - P05 = Number of selected titles
 - P06 = Number of selected albums
 - P07 = Number of free credits provided
 - P08 = Number of background CD's played
- Erase counters: P10, Code "1", counters P01 to P08 are erased.
- For more information see "Statistics and Service Programs", Section 1.1, Statistics Program, P01 to P12!

Statistics and Service Programs CD

P01	Popularity beginning with least played CD upwards	P02	Pop. beginning with most played CD downwards	BUT.		
	No. of least played CD		No. of most played CD	0		
	No. of next least played CD		No. of next most played CD	1		
	Rank of CD displayed		Rank of CD displayed	2		
	Times played		Times played	3		
	Information about a certain CD		Information about a certain CD	4		
P03	Total cash in monetary units	P04	Counter of played titles	0		
	Total cash cumulative in monetary units/100		Counter of played titles accumulated	1		
P05	Number of selected title	P06	Counter of album selections			
P07	Number of free credit	P08	Counter of played album titles			
P10	Cancel of counters	P12	Transfer of DATA PRINT **)			
	Popularity, HIT-Parade, Counter P03-P08, Credit		Counter P03-P08	1, H		
	Popularity (P01, P02), HIT-Parade		Counter P03-P08; Settings P21-P56	2, H		
	Counter P03-P08		Popularity, Counter P03-P08	3, H		
	Credit		Pop. counter P03-P08; Settings P21-P56	4, H		
P11	Data transfer and memory (storage) *)			1, H		
P20	Autom. programming of the prog. steps P21-P39 according to table			1, H		
P21	Unit code	P22	No. max. CD-Tracks to be selected	P23	No. of free credits	x, H
P24	Random play interval	P25	No. of CD's progr. f. backgr. music	P26	Light gener. f. stand by (***)	x, H
P27	Light gener./organ for play (***)	P28	Maximum volume			x, H
P30	Max. play time for a title *)	P31	Sequence of plays *)	P32	Max. titles in CD sequence *)	x, H
P38	Authorization with code numb	P39	Code number			x, H
P40	Autom. programming of the steps P41 thru P46 (play/cash value) according to table					x, H
P46	No. of credits for an album selection					x, H
P50	Autom. programming of the steps P51 thru P56 (coin value acceptance) to table					x, H
P56	Bonus credit for Bill					x, H
P60	Test programs					x, H
P61	Programming optional Numbers of CD-Tracks					xxxx, H
P62	Read-out of error code					0; 1; 2; 3; 4, 1, H

***) If installed

) from Progr.-Index 004;

*) from Progr.-Index 003.

Test Programs

		(Interrupt / run)			H
P60	<p>Display 1</p> <p>Display 2</p> <p>Display 3</p> <p>Error Display</p> <p>Display and light test: F 1</p> <p>Input test: F 2 Port-No. Bit-No. Status</p> <p>Continuous Run 1 (playing continuously): F 3 Number of errors</p> <p>Continuous Run 2 (repeatedly playing): F 4 Number of errors</p> <p>CD = Changer test:</p> <p>"2" = Lift upwards</p> <p>"8" = Lift downwards</p> <p>"4" = Grip left</p> <p>"6" = Grip right</p> <p>"5" = Return holder</p> <p>"0" = Keep lift position</p> <p>"3" = Motor step, upwards *)</p> <p>"9" = Motor step, downwards *)</p> <p>OPTO stepper control OPSTP</p> <p>OPTO endposition OPEND</p> <p>OPTO grip right OPGRR</p> <p>OPTO pickup center OPPUM</p> <p>OPTO grip left OPGRL</p> <p>With Display "0" = lit up</p> <p>With Display "1" = darkened</p>				1, H 2, H 3, H 4, H 5, H
P61	Number of track numbers				[xxxx, H
P62	Error code of least error				0
	Error code of previous errors (up to 10)				1
	No. of CD at which error occurred				2
	Time in hrs./min. since "power on" or start of P60/3 or P60/4 when error occurs				3
	Cancellation of stored error code				4

*) from Progr.-Index 004

Error Messages

Er	Error	Action
0x	EPR0M	Check or replace corresponding component or unit. See special information in "TROUBLE SHOOTING".
1x	RAM	
2x	Program	
3x	Verifaction	
4x	Price settings	
5x	Coin mechanism/ Bill vallidator	
5x	CD-Player	
7x	CD-Changer	
8x	Wallbox-Connection	
9x	Title indication	

SHORT INSTRUCTION:

For statistics and service programs; test programs, error displays.

Detailed description in Section 3 "Statistics and Service Programs" as well as Section 14 "Trouble-Shooting".

UNIT DESCRIPTION

OUTPUT STAGE

FOR NSM-PHONOGRAPHS

ES IV-CD TECHNOLOGY

to
Technical Information, Assy

174 903	SILVER CITY
174 831	SILVER SKY
174 486	FASCINATION
175 274	SOUNDMASTER
175 040	FIREBIRD/COUNTRY
176 046	THE PERFORMER "GRAND"

NSM
Aktiengesellschaft
Saarlandstraße 240
6530 Bingen am Rhein

7

Page 701-704

Output Stage

The output stage is designed without induction coils or transformer and is therefore ironless. At full volume the music power is 200 W per channel when connected to a 2-ohm loudspeaker impedance.

Functions such as power supply, signal path and settings as well as repair aids are described in detail in the unit description "CENTRAL UNIT".

SPARE PARTS LIST

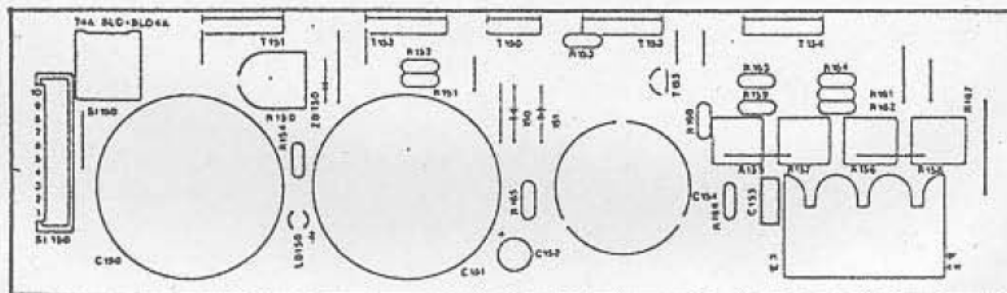

SPARE PARTS LIST

POS.	PART-No.	DESCRIPTION	DATA	QTY
	171 701	<u>OUTPUT STAGE, ASSY</u>	<u>50 Hz</u>	1
SI 150	225 036	FUSE	T 4 A slo blo	1
	225 747	CAP		1
	171 702	<u>OUTPUT STAGE, ASSY</u>	<u>60 Hz</u>	1
SI 150	225 542	FUSE	T 4 A slo blo	1
	225 748	CAP		1
	171 696	CHASSIS		1
	171 881	VENTILATOR, ASSY		1
	171 699	AIR VANE		1
	222 485	TEMPERATURE CONTROLLER		1
		<u>CB - OUTPUT STAGE</u>		1
ST 150	225 422	TERMINAL BOARD	3 prongs	1
	225 654	PIN PANEL	black 10 prongs	1
	225 746	FUSE HOLDER		2
D 150, 151	221 115	SI-DIODE	1 N 4004	2
ZD 150	221 650	SI-ZENER-DIODE	ZPD 33	1
LD 150	221 466	LIGHT EMITTING DIODE	CQY 65	1
T 150	221 883	SI-TRANSISTOR	NPN BD 239 B	1
T 155	221 459	SI-TRANSISTOR	PNP BD 256	1
T 151, 152	221 886	DARLINGTON-TRANSISTOR	NPN BDW 83 C	2
T 153, 154	221 902	DARLINGTON-TRANSISTOR	PDP BDW 84 C	2
C 153	220 333	MET.-CAPACITOR	0,22 μ F 63 V	1
C 152	220 162	LYTIC	10 μ F 63 V	1
C 154	220 396	LYTIC	4700 μ F 50 V	1
C 150, 151	220 436	LYTIC	4700 μ F 63 V	2
R 166	221 094	RESISTOR	2,7 Ω $\frac{1}{2}$ W	1
R 152, 153	221 096	RESISTOR	56 Ω $\frac{1}{2}$ W	2
R 151	231 154	RESISTOR	750 Ω $\frac{1}{2}$ W	1
R 159-162	221 029	RESISTOR	1 K Ω $\frac{1}{2}$ W	4
R 164	221 032	RESISTOR	2,7 K Ω $\frac{1}{2}$ W	1
R 163	221 034	RESISTOR	4,7 K Ω $\frac{1}{2}$ W	1
R 154	221 625	RESISTOR	5,6 K Ω $\frac{1}{2}$ W	1
R 165	221 604	RESISTOR	22 K Ω $\frac{1}{2}$ W	1
R 167	221 267	WIRE WOUND RESISTOR	470 Ω 1 W	1
R 155-158	221 275	WIRE WOUND RESISTOR	0,22 Ω 7 W	4
R 150	221 305	TRIMMER RESISTOR	2,2 K Ω 0,1 W	1

Thermoschalter
TEMPERATURE SWITCH

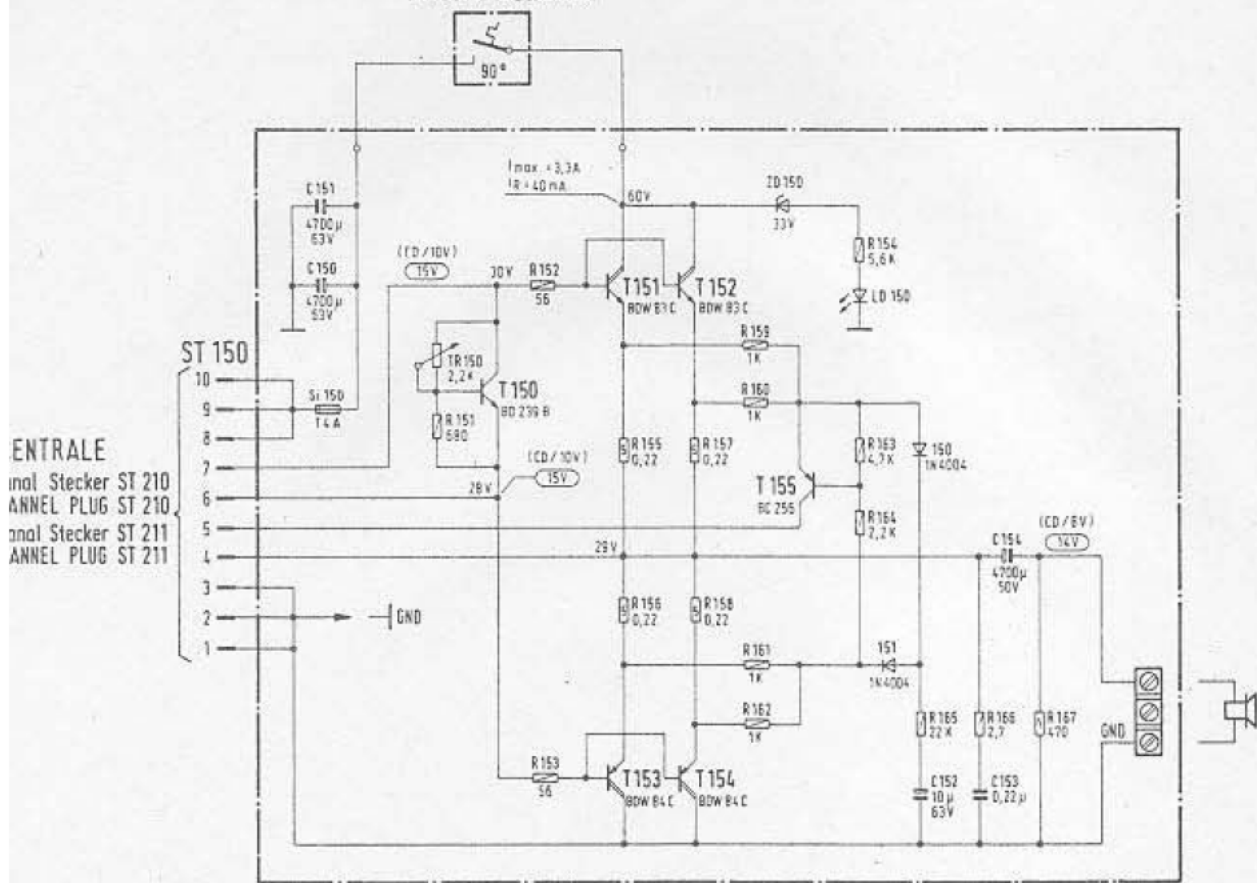

ENTRALE
anal Stecker ST 210
ANNEK PLUG ST 210
anal Stecker ST 211
ANNEK PLUG ST 211

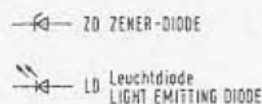
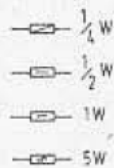

Draufsicht
TOP VIEW



von unten gesehen
BOTTOM VIEW

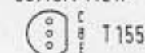

NF-Pegel bei 1 KHz; Lautstärkesteller auf max.
Höhen und Bässe max., ohne (CD/mit) AVC gemessen mit elektron. Voltmeter.
Gleichspannung gemessen mit Voltmeter $R_i = 10 \text{ M}\Omega$.

AC SIGNAL VOLTAGES AT 1000 cps, VOLUME CONTROL TO MAX. TREBLES AND
BASSES MAX., WITHOUT (CD/WITH) AVC MEASURED WITH ELECTRONIC VOLTMETER.
DC VOLTAGES MEASURED WITH VOLTMETER $R_i = 10 \text{ MEG OHMS}$.

Alle Sicherungen träge!
ALL FUSES SLO BLO!

Sicherungen nur durch solche mit gleichen Werten ersetzen!
REPLACE FUSES ONLY BY THOSE OF THE SAME VALUE!

ÄNDERUNGEN IM SINNE DES TECHN. FORTSCHRITTES VORBEHALTEN,
JEDOCH KEINE NACHRÜSTPFLICHT!

SUBJECT TO TECHNICAL MODIFICATION WITHOUT OBLIGATION
TO MODIFY EQUIPMENT ALREADY DELIVERED!



MUSIKAUTOMATEN
PHONOGRAPHS

ES IV-CD TECHNOLOGY

Schaltbild Endstufe
WIRING DIAGRAM OUTPUT STAGE

Druck	Gez	Freigegeben	Gezeichnet
27 01 89	Braun		

UNIT DESCRIPTION

OUTPUT TRANSFORMER

FOR NSM-PHONOGRAPHS

EE IV-CD TECHNOLOGY

to
Technical Information, Assy

174 903	SILVER CITY
174 831	SILVER SKY
174 486	FASCINATION
175 274	SOUNDMASTER
175 040	FIRE BIRD/COUNTRY

NSM
Aktiengesellschaft
Saarlandstraße 240
6530 Bingen am Rhein

13

Page 1301-1304

OUTPUT TRANSFORMER with cable harness

Part.-No. 172 431

The output transformer is connected directly to the terminals of the output amplifier. It has input impedance of 4 ohms and transforms the input voltage down so that smaller output voltages are available at Connection Terminals 1 through 5 permitting speakers with lower impedances to be connected.

A number of loudspeakers can be connected together (in parallel) up to a total maximum power of 130 W music power per channel; depending on how much power is taken directly from the amplifier.

The table below shows the power required for a loudspeaker with the corresponding impedance at Connection Terminals 0-1 through 0-5. Also observe the output transformer diagram and connection schematics. Further information is given in the "TECHNICAL INSTRUCTIONS" under "Loudspeaker Connection".

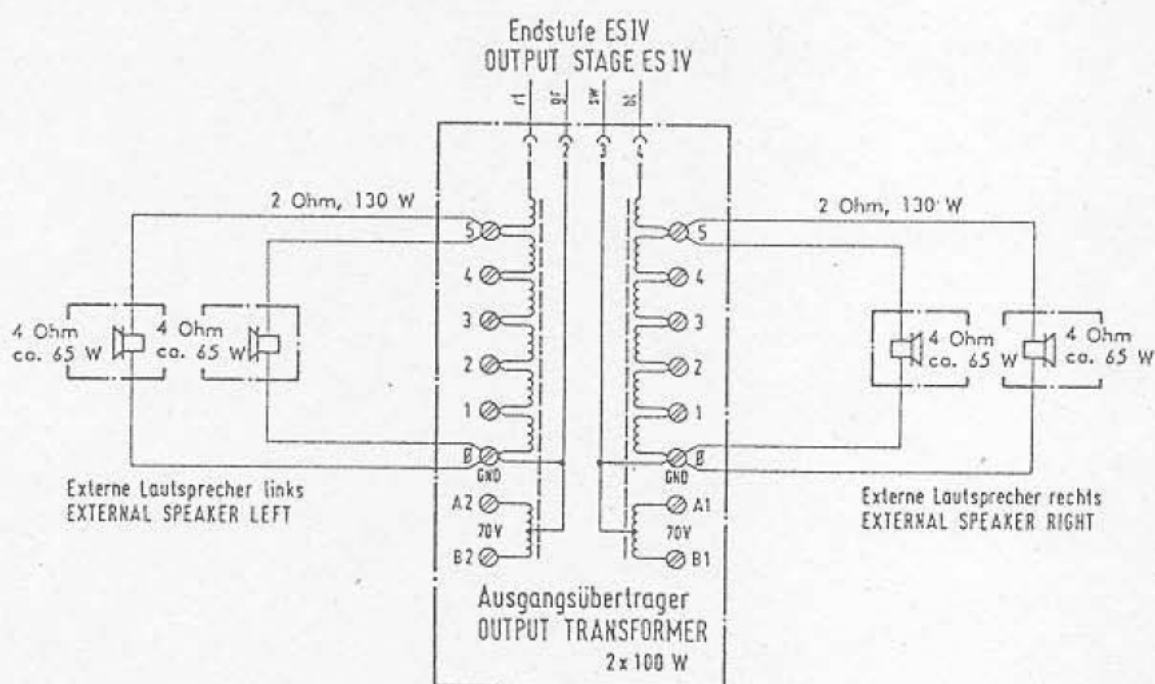

Anschlußschema für Ausgangsübertrager
CONNECTION DIAGRAM FOR OUTPUT TRANSFORMER

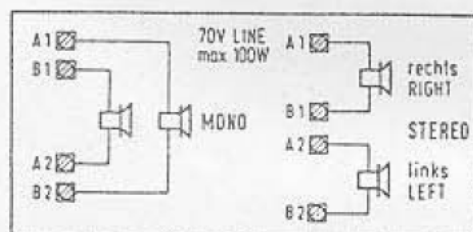

Klemme TERMINAL POSITION	Lautsprecher SPEAKER				
	2 Ω	2.5 Ω	4 Ω	8 Ω	16 Ω
0 - 5	130 W	100 W	70 W	45 W	22 W
0 - 4	60 W	45 W	30 W	16 W	8 W
0 - 3	30 W	24 W	15 W	8 W	4 W
0 - 2	15 W	12 W	7.5 W	4 W	2 W
0 - 1	3.7 W	3 W	1.8 W	1 W	0.5 W

Maximum Power Output Connections

The maximum power output of the amplifier is 2x200 W music power at 2 ohms.

The following is an example of how to connect external loudspeakers to the "CD GALAXY": The phonograph itself consumes (when directly connected at 5,5 ohm impedance) 2x70 watts.

Therefore, 2x130 W is still available for external loudspeakers.

For example, two 4-ohm loudspeakers each can be connected to Terminals 0-5 (see diagram) or four loudspeakers (with 4 ohms each) can be connected to Terminals 0-4.

Example for connection of wallboxes or Hide-Away's

If loudspeakers with 4 ohm are connected directly to a wallbox or Hide-Away, the consumption is 100 watts; therefore there is only 100 watts left for the loudspeaker connected to the transformer.

Connection for Lower Phonograph Output Power

When full power is not required from the phonograph, it can be connected to the corresponding terminals of the transformer and external loudspeakers can then be connected directly to the output amplifier for higher output.

70 V - High Voltage Output

Additionally, the transformer also has a 70 V high-voltage output (A1-B1/A2-B2) for each channel.

These features are provided for operation of a widespread external loudspeaker system whereby the higher voltage keep the line losses low. Only loudspeakers with input transformers (so-called high-impedance loudspeakers of 50 ohms upwards) can be connected to this terminal. these outputs also provide a maximum of 100 W music power each, e.g. two 50 W loudspeakers (200 ohms) can be connected to each channel.

Lautsprecher-Impedanz Loudspeaker-Impedance	Ausgangsleistung Output power	A1-B1 A2-B2
50 Ohm	100 W	
100 Ohm	50 W	
150 Ohm	35 W	
200 Ohm	28 W	
250 Ohm	20 W	

The total wattage of all remote loudspeakers connected to one channel of the output transformer (whether low impedance, high impedance or combined) may not exceed max. 130 W.

HV - MONO Mode

Since the high-voltage coils are connected with their center, a loudspeaker connected to A1-B2 or B1-A2 radiates sound from both (stereo) channels; for this mono mode no special NF-coupling of the channels is necessary, coupling is provided by the transformer.

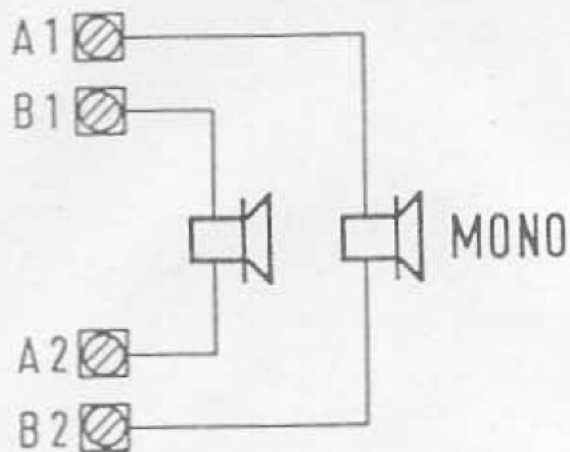

HV - STEREO Mode

If the loudspeakers are connected to A1-B1 or A2-B2, stereo mode is possible, but without NF-coupling of the channels.

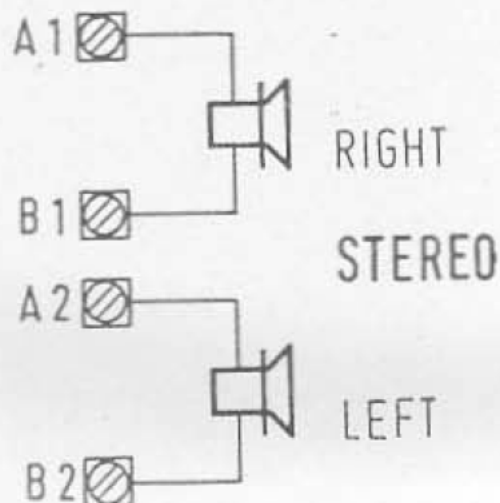

SPARE PARTS LIST
FOR NSM-PHONOGRAPH
THE PERFORMER
"GRAND"

This spare parts list is applicable for NSM-Phonograph: THE PERFORMER "GRAND"

Every spare part order should contain the following:

1. Model
2. Serial number
3. Quantity
4. Part number
5. Description

Example

Model	Serial-Number	QTY	Part-No.	Description	Data
THE PER- FORMER "GRAND"	02 904	1	174 788	LINE TRANSFO	CD-Player
		2	224 188	BALLAST	VG 13/2 KY
		1	225 343	STARTER	S2

ATTENTION!

Precise orders save unnecessary questions and bring the best results.

ORDER SPARE PARTS THRU YOUR NSM-DISTRIBUTOR!

Information and illustrations contained in this spare parts list, are correct at the time of going to press.

NSM-AKTIENGESELLSCHAFT, Saarlandstraße 240 - W-6530 BINGEN am Rhein

INDEX

Page 121	UNITS and ACCESSORIES
Page 122-125	CABINET
Page 126-128	LID
Page 128	CABLE HARNESSSES

SPARE PARTS LIST

POS.	PART-No.	DESCRIPTION	DATA	QTY	
<u>PHONOGRAPH - THE PERFORMER "GRAND"</u>					
<u>UNITS and ACCESSORIES</u>					
174	873	CB - CONTROL UNIT CD, ASSY	see Page 406	1	
173	664	CB - DISPLAY CD, ASSY	see Page 504	1	
173	666	CB - CENTRALE CD, ASSY	see Page 608	1	
171	701	OUTPUT STAGE	50 Hz	see Page 703	>
171	702	OUTPUT STAGE	60 Hz	see Page 703	1
175	980	CD-CHANGER 100 (without Design Pieces)	see Page 806	1	
175	977	VIEW GLASS		1	
175	998	FRONT TRIMPLATE		1	
175	992	SIDE TRIMPLATE, LEFT		2	
175	993	SIDE TRIMPLATE, RIGHT		1	
212	555	TRIM PLATE		1	
219	508	COLOR FOIL		2	
174	710	CD-TITLE INDICATION II, ASSY	see Page 904	1	
171	799	OUTPUT TRANSFORMER		1	
174	915	CABLE HARNESS		1	
174	258	IR-REMOTE CONTROL, ASSY		1	
206	783	SENDER		1	
173	178	RECEIVER		1	
171	883	CONNECTING CABLE f. RECEIVER	1,5 m	>	
170	459	CONNECTING CABLE f. RECEIVER	5,0 m	1	
171	743	REMOTE CONTROL	w. 5 m CABLE	>	
172	077	REMOTE CONTROL	w. 20 m CABLE	1	
224	223	MICROPHONE		1	
171	880	MICROPHONE CABLE	10 m	>	
172	187	MICROPHONE CABLE	25 m	1	
173	985	WALLBOX-CONNECTING, ASSY		1	
172	025	TAPE-CONNECTING CABLE		1	
173	348	CASH COUNTER, ASSY		1	
174	648	CB - AUDIO CONNECTION		1	
175	376	DATA PRINT 2000		1	

SPARE PARTS LIST

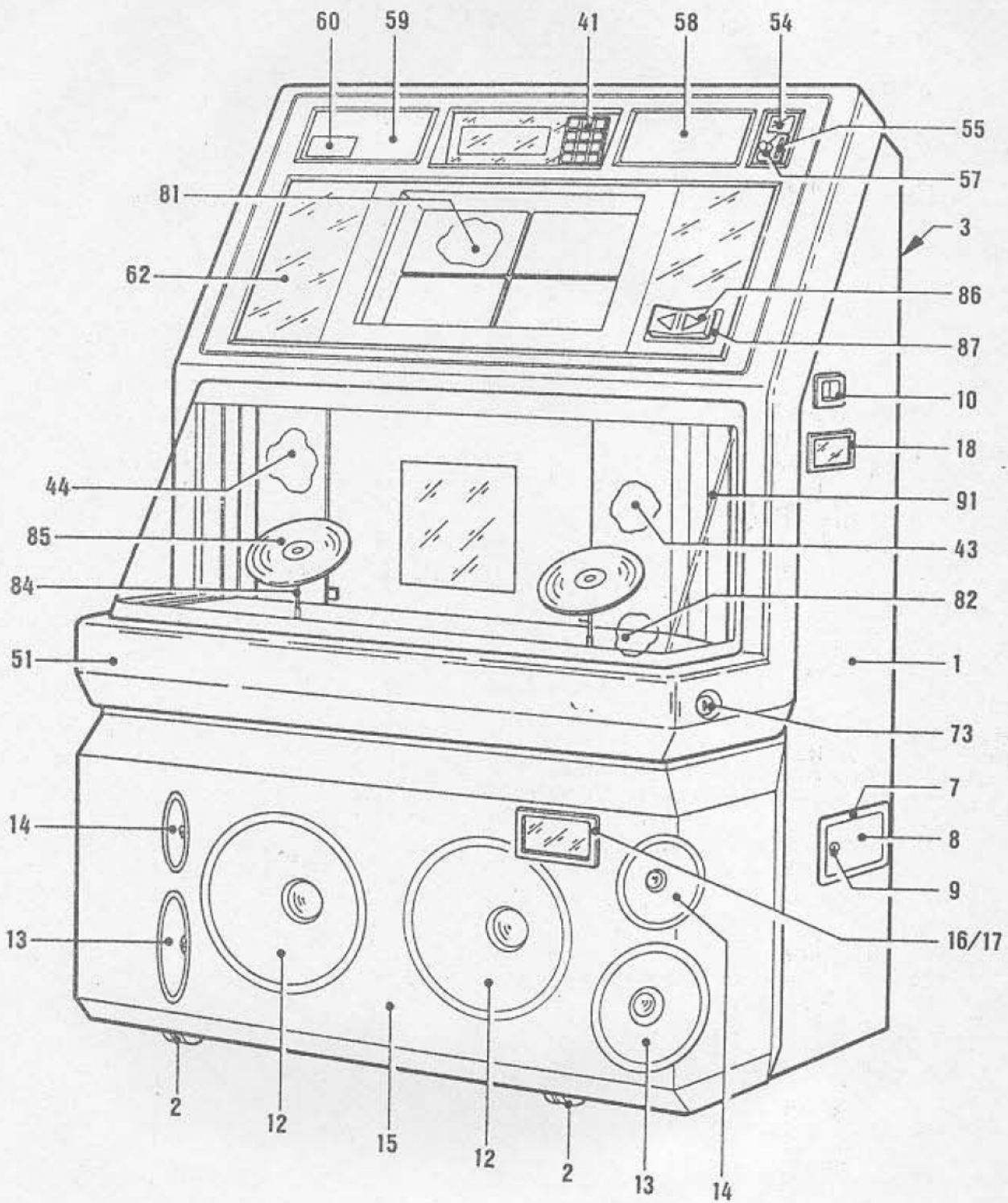

SPARE PARTS LIST

POS.	PART-No.	DESCRIPTION	DATA	QTY	
<u>PHONOGRAPH THE PERFORMER "GRAND"</u>					
1	203 824	CABINET		1	
2	217 506	ROLLER		4	
3	170 852	HANDLE		4	
4	173 968	TRANSFORMER PLATE	(In REAR WALL)	1	
	217 772	HINGE		1	
5	223 418	TRANSFORMER		1	
6	174 788	LINE TRANSFORMER, ASSY	(CD-PLAYER)	1	
	225 907	TRANSFORMER-FUSE	0,25 A	1	
7	174 501	CASH FRAME		1	
8	174 500	CASH-DOOR		1	
9	207 008	CYL.-LOCK with KEYS	DOM Typ 447-04-01	1	
	207 496	CASH BAG		1	
10	174 818	COIN RETURN CUP		1	
	174 499	COIN LID		1	
	172 474	COVER		1	
11	172 519	NETWORK		2	
	171 289	SPACER		6	
12	224 240	LOUDSPEAKER	4 Ohms pmt 300	2	
	173 970	DECOR RING		2	
13	224 241	LOUDSPEAKER	8 Ohms P 175	2	
14	224 242	LOUDSPEAKER	8 Ohms P 135	2	
	173 971	DECOR RING		2	
15	176 021	SPEAKER GRILL		1	
15a	250 366	PROFILE, FRONT		2	
15b	250 365	PROFILE, LOWER		2	
16	172 531	FRAME		1	
17	212 517	MASK		1	
	212 516	GLASS		1	
18	114 664	FRAME for ADDRESS CARD		1	
	215 008	ADDRESS CARD		1	
19	172 611	PLATE, STAMPED		1	
	171 928	FLAT SPRING		1	
ACCEPTOR	21	172 410	SUPPORT	1	
		172 412	BOLT	1	
		172 415	COIN RETURN LEVER	1	
		170 069	HOLDER	1	
		170 031	COIN CHUTE, ASSY	1	
		171 905	COIN TUBE	1	
		172 461	HOLDING BRACKET	1	
		172 545	COIN TUBE	COIN RETURN CUP	1
		172 418	HOLDING BRACKET		1
		172 546	COIN TUBE	CASH BOX	1

SPARE PARTS LIST

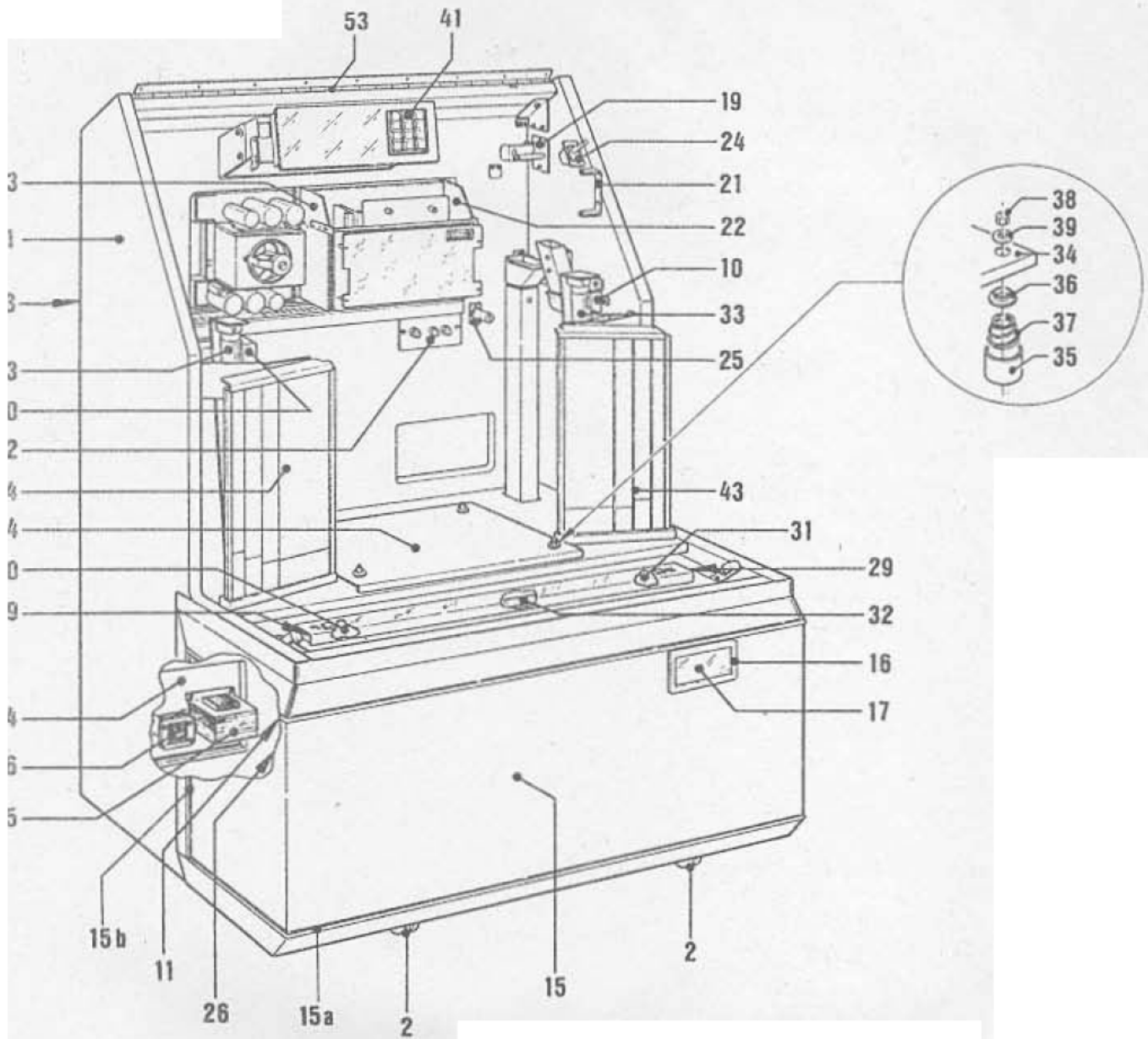

SPARE PARTS LIST

MARS-MÜNZ
ACCEPTOR

POS.	PART-No.	DESCRIPTION	DATA	QTY	
-21	172 571	SUPPORT		1	
	172 572	MOUNTING PLATE, STAMPED		1	
	172 183	BRACKET		1	
	172 574	COIN RETURN LEVER, STAMPED		1	
	172 576	HOLDING BRACKET		1	
	172 577	COIN TUBE	CASH BOX	1	
	172 139	LP-Mars-Münzprüfer		1	
22	173 722	BRACKET, ASSY	RIGHT	CONTROL UNIT	1
23	173 723	BRACKET, ASSY	LEFT	and CENTRALE	1
24	172 724	SWITCH PLATE		1	
	222 509	PUSH BUTTON SWITCH		1	
25	174 252	HOLDING PLATE		1	
	222 505	KEY SWITCH		1	
26	176 050	SUPPORT PLATE		1	
	224 064	BALLAST	KX 16 D	1	
	224 188	BALLAST	KX 13 D	2	
	225 040	STARTER	S10	3	
	225 343	STARTER	S2	2	
29	175 995	LAMP HOLDER		2	
30	225 756	LAMP SOCKET		1	
31	225 757	LAMP SOCKET with STARTER SOCKET		1	
32	226 073	FLUORECENT LAMP	50 Hz 16 W	1	
	226 074	FLUORECENT LAMP	60 Hz	1	
	219 493	Transparentfolie		1	
33	226 085	FLUORECENT LAMP	TL-D 15 W	2	
34	174 765	BOTTOM PLATE		1	
35	170 007	SOCKET		4	
36	170 006	GUIDE SPACER		4	
37	205 353	CONE SPRING		4	
38	023 380	HEX NUT		4	
39	170 005	WASHER		4	
40	171 725	JUNCTION PLATE, ASSY	50 Hz	1	
	171 726	JUNCTION PLATE, ASSY	60 Hz	1	
41	175 905	KEY BOARD, ASSY		1	
42	175 402	JUNCTION PLATE		1	
	222 452	BUTTON, green		1	
	222 470	BUTTON, white		1	
	222 471	BUTTON, red		1	
	175 365	CABLE HARNESS		1	
43	212 561	SIDE TRIMPLATE, RIGHT		1	
44	212 550	SIDE TRIMPLATE, LEFT		1	

SPARE PARTS LIST

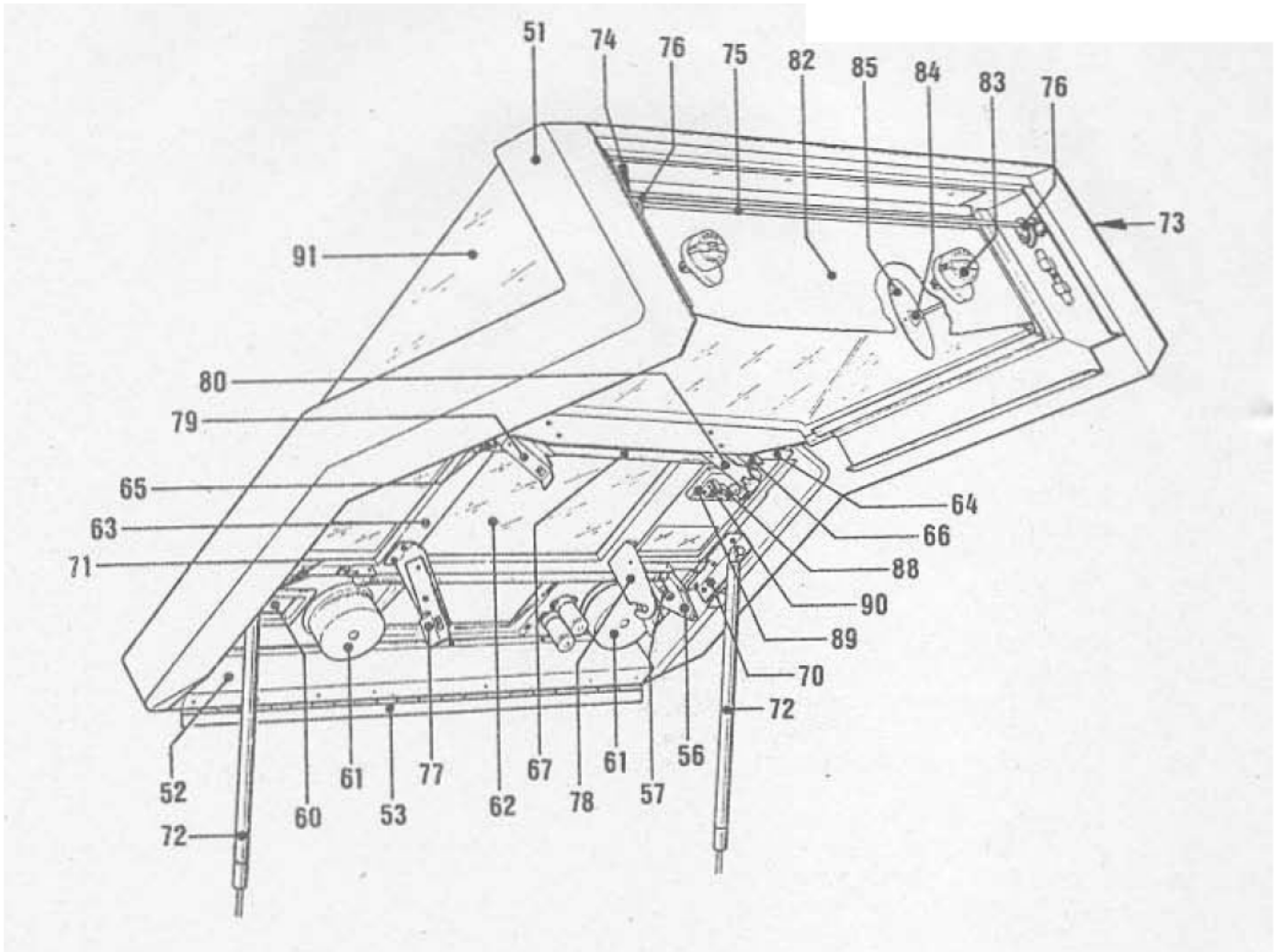

SPARE PARTS LIST

POS.	PART-No.	DESCRIPTION	DATA	QTY
<u>COVER</u>				
51	176 027	COVER, PRE-MOUNTED		1
52	172 375	BACK PLATE		1
53	206 297	HINGE		1
54	212 554	GLASS, PRINTED		1
55	176 078	COIN INSERT		1
56	176 079	COIN CHANNEL		1
57	171 662	COIN REJECT		1
58	174 849	BACKPLATE, RIGHT		1
	209 065	PROTECTIVE TISSUE, RIGHT		1
59	174 871	BACKPLATE, LEFT		1
	209 066	PROTECTIVE TISSUE, LEFT		1
60	172 403	CLOSING PLATE	DOLLAR BILL	1
61	224 233	LOUDSPEAKER	4 Ohms SKK 10	2
62	214 002	GLASS, UPPER	GERMANY	1
	217 507	RUBBER PROFILE	2x800 / 2x275 lg	-
63	174 803	SUPPORT, ASSY		1
64	174 815	PRESSURE PLATE		2
65	174 805	LAMP HOLDER, LEFT		2
66	174 804	LAMP HOLDER, RIGHT		2
67	226 075	FLUORESCENT LAMP	13 W	2
	219 507	FOIL	f. LAMP, UPPER	1
70	172 479	HOLDING BRACKET, RIGHT STAMPED		1
71	172 372	HOLDING BRACKET, LEFT STAMPED		1
72	206 320	PISTON ROD		2
73	217 814	CYL.-LOCK		1
	217 992	SPARE KEY		-
74	172 469	BRACKET		1
75	172 447	CLOSING RAIL		1
76	171 616	CLOSING NOSE		2
77	176 015	BRACKET, RIGHT UPPER, STAMPED		1
78	176 016	BRACKET, LEFT UPPER, STAMPED		1
79	176 018	BRACKET, RIGHT LOWER, STAMPED		1
80	176 017	BRACKET, RIGHT LOWER, STAMPED		1
81	174 710	CD-TITLE INDICATION II		1

SPARE PARTS LIST

POS.	PART-No.	DESCRIPTION	DATA	QTY
82	212 559	LOWER MASK		1
83	176 061	MOTOR, ASSY		2
84	176 001	CD-HOLDER		2
85	206 658	CD-NON PLAY BACK		2
86	175 974	BUTTON		1
87	175 973	FRAME		1
	207 199	RUBBER PROFILE	2x100 / 2x60 lg	4
88	176 003	FLAT SPRING		1
89	175 981	COVER		1
90	222 547	SWITCH		2
91	176 019	GLASS	HYPERBEAM™	1
	206 333	RUBBER PROFILE	1595 lg	1
	206 334	RUBBER PROFILE	1300 lg	1

CABLE HARNESS

172 506	DISPLAY	1100 lg 10 prongs	1
172 508	CENTRALE OUTPUT STAGE	700 lg 10 prongs	2
176 109	LOUDSPEAKER		1
171 790	CENTRALE -- LINE TRANSFORMER		1
171 782	CENTRALE -- CONTROL UNIT	120 lg 15 prongs	1
171 783	CENTRALE -- CONTROL UNIT	120 lg 12 prongs	1
173 164	CENTRALE -- CD PLAYER		1
151 626	CONTROL UNIT -- CD PLAYER		1
173 963	TRANSFORMER -- CD PLAYER		1
174 910	CENTRALE -- LP TITLE STRIP HOLDER		1
173 966	CD-AUDIO		1
174 916	TITLE DRUM		1

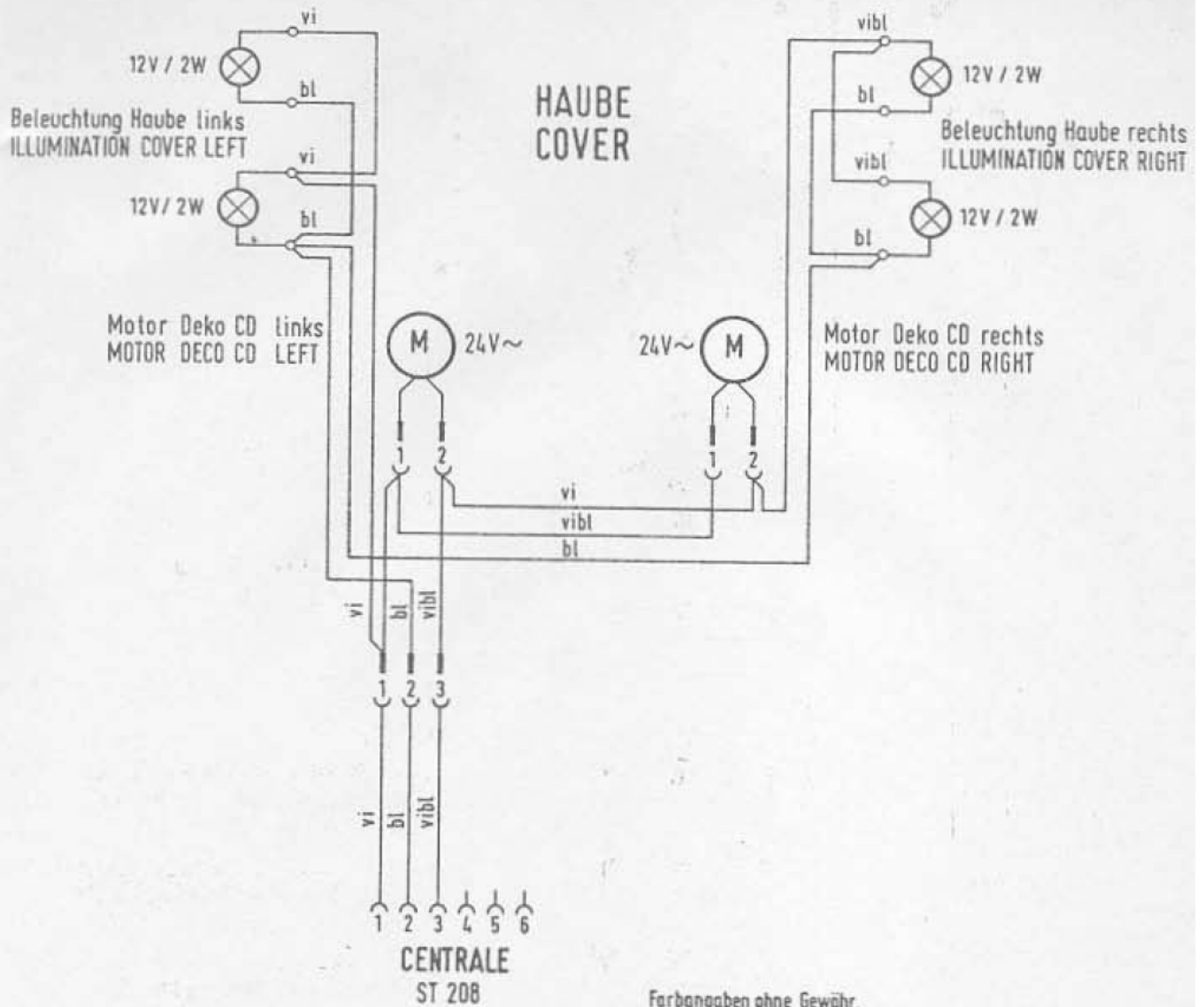

Farbangaben ohne Gewähr.
COLOR INDICATION WITHOUT WARRANTY.

ÄNDERUNGEN IM SINNE DES TECHN. FORTSCHRITTES VORBEHALTEN,
JEDOCH KEINE NACHRÜSTPFLICHT!

SUBJECT TO TECHNICAL MODIFICATION WITHOUT OBLIGATION
TO MODIFY EQUIPMENT ALREADY DELIVERED!

Farbspiegel
COLOR CODE

ws	weiß	white
bl	blau	blue
br	braun	brown
ge	gelb	yellow
gn	grün	green
gr	grau	grey
or	orange	orange
rs	rosa	pink
rt	rot	red
sw	schwarz	black
vi	violett	violet

 MUSIKAUTOMATEN
PHONOGRAPHS

ES IV - CD TECHNOLOGY

Schaltbild
WIRING DIAGRAM

Dekorbeleuchtung
ILLUMINATION DECOR

THE PERFORMER

"GRAND"

Det. 08.08.91	Gez. Braun	Besrh.	Gepr.
------------------	---------------	--------	-------

Zum Netz-Transformator
TO MAINS TRANSFORMER

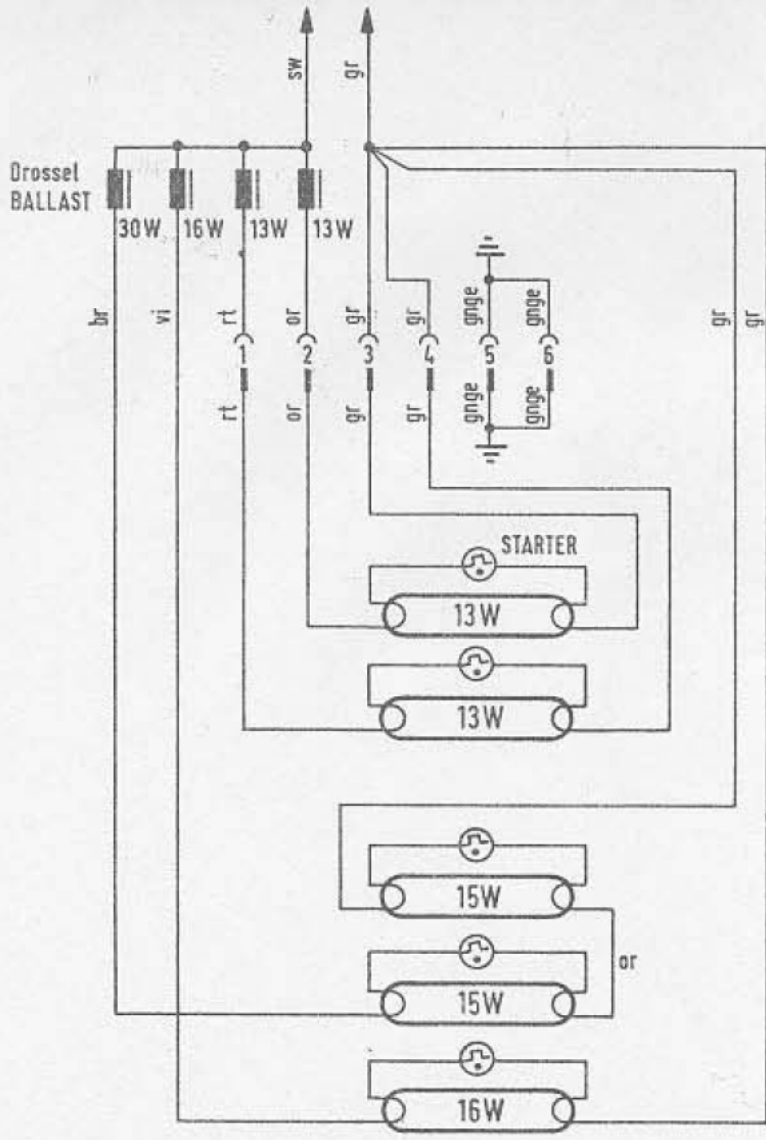

Leuchtstofflampen Haube
FLUORESCENT LAMPS COVER

Leuchtstofflampe Gehäuse - links
FLUORESCENT LAMP CABINET -LEFT

Leuchtstofflampe Gehäuse - rechts
FLUORESCENT LAMP CABINET -RIGHT

Leuchtstofflampe Gehäuse
FLUORESCENT LAMP CABINET

Farbangaben ohne Gewähr.
COLOR INDICATION WITHOUT WARRANTY.

ÄNDERUNGEN IM SINNE DES TECHN. FORTSCHRITTES VORBEHALTEN,
JEDOCH KEINE NACHRÜSTPFLICHT!

SUBJECT TO TECHNICAL MODIFICATION WITHOUT OBLIGATION
TO MODIFY EQUIPMENT ALREADY DELIVERED!

Farb Spiegel
COLOR CODE

ws	weiß	white
bl	blau	blue
br	braun	brown
ge	gelb	yellow
gn	grün	green
gr	grau	grey
or	orange	orange
rs	rosa	pink
rt	rot	red
sw	schwarz	black
vi	violett	violet



MUSIKAUTOMATEN
PHONOGRAPHS

ES IV - CD TECHNOLOGY

Schaltbild
WIRING DIAGRAM

Beleuchtung
ILLUMINATION

THE PERFORMER

[50HZ]

“GRAND”

Dat.	15.08.91	Gez.	Braun	Bearb.		Gepr.	
------	----------	------	-------	--------	--	-------	--

Zum Netz - Transformator TO MAINS TRANSFORMER

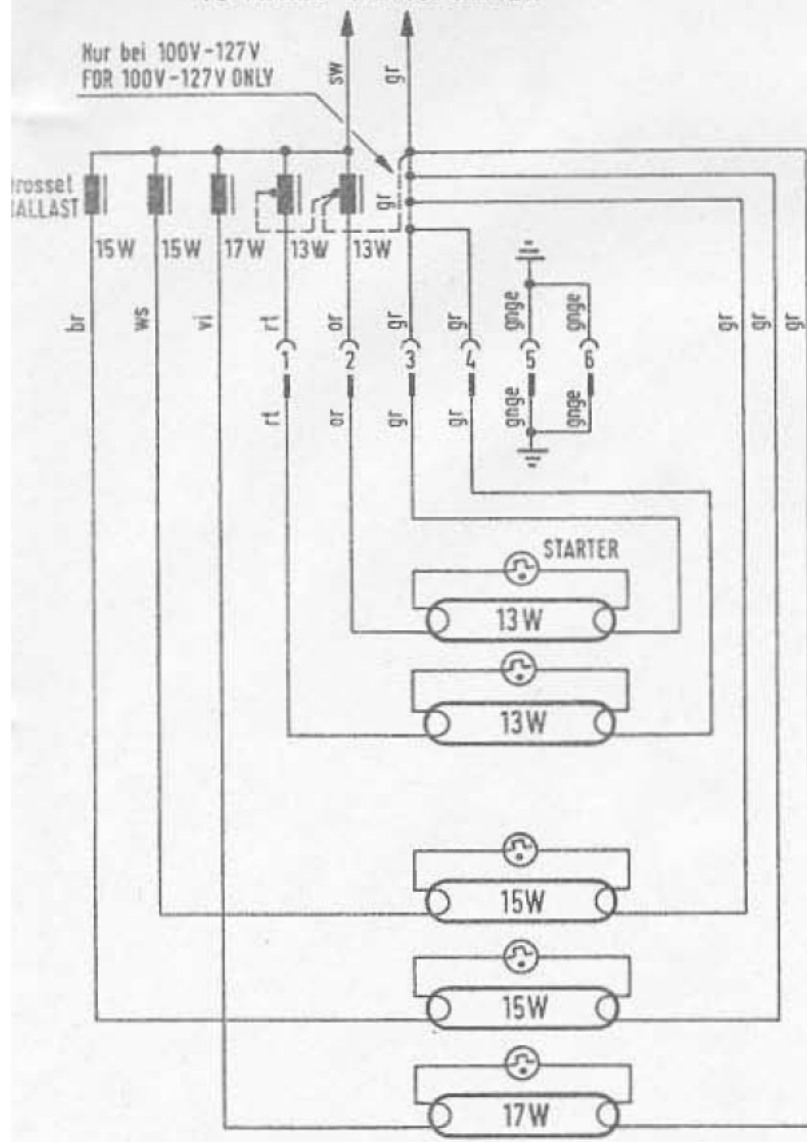

Leuchtstofflampen Haube
FLUORESCENT LAMPS COVER

Leuchtstofflampe Gehäuse - links
FLUORESCENT LAMP CABINET - LEFT

Leuchtstofflampe Gehäuse - rechts
FLUORESCENT LAMP CABINET - RIGHT

Leuchtstofflampe Gehäuse
FLUORESCENT LAMP CABINET

Farbangaben ohne Gewähr.
COLOR INDICATION WITHOUT WARRANTY.

ÄNDERUNGEN IM SINNE DES TECHN. FORTSCHRITTES VORBEHALTEN,
JEDOCH KEINE NACHRÜSTPFLICHT!

SUBJECT TO TECHNICAL MODIFICATION WITHOUT OBLIGATION
TO MODIFY EQUIPMENT ALREADY DELIVERED!

Farbspiegel COLOR CODE

ws	weiß	white
bl	blau	blue
br	braun	brown
ge	gelb	yellow
gn	grün	green
gr	grau	grey
or	orange	orange
rs	rosa	pink
rt	rot	red
sw	schwarz	black
vi	violett	violet



MUSIKAUTOMATEN
PHONOGRAPHS

ES IV - CD TECHNOLOGY

Schaltbild
WIRING DIAGRAM

Beleuchtung
ILLUMINATION

THE PERFORMER

GRAND

[60HZ]

Dat.	08 08 91	Gez.	Braun	Bearb.		Gepr.	
------	----------	------	-------	--------	--	-------	--

TECHNICAL INSTRUCTIONS

FOR NSM-PHONOGRAPHS

THE PERFORMER

"GRAND"

ES IV-CD TECHNOLOGY

TO TECHNICAL INFORMATION, ASSY -176 046-

NSM
Aktiengesellschaft
Saarlandstraße 240
6530 Bingen am Rhein

1

Page 101-131/141

INDEX

- 1 PLEASE READ INSTRUCTIONS
 - 1.1 Transport damages
 - 1.2 Keys
 - 1.3 Transport devices
 - 1.4 Power connection
 - 1.5 Title strips and CD's

- 2 LAYOUT OF UNITS
 - 2.1 Display / Keyboard

- 3 SPECIFICATIONS
 - 3.1 Electrical data
 - 3.2 Music power
 - 3.3 Fuses
 - 3.4 Lighting
 - 3.5 Credit / Cash input
 - 3.6 Keyboard
 - 3.7 Display
 - 3.8 CD changer
 - 3.9 Loudspeakers
 - 3.10 Special features
 - 3.11 Dimensions

- 4 LOUDSPEAKER CONNECTION
 - 4.1 Output transformer

- 5 SPARE PARTS LIST "CABINET"

- 6 WIRING DIAGRAM - ILLUMINATION
 - 6.1 WIRING DIAGRAM - LIGHT GENERATOR/ORGAN
 - 6.2 OPERATING SCHEME ES IV-CD TECHNOLOGY

NOTE!

The playing and operating instructions for album selection are covered with a black sticker from the rear in the factory. If album selection should be allowed, remove the black sticker and replace it with the white sticker from the accessory pack.

TO MAKE SELECTIONS

1 INSERT COINS OR BILLS AS SHOWN

2 PRESS 2 DIGIT DISC NUMBER THEN PRESS 2 DIGIT TRACK NUMBER



WHILE DISC ALBUM
DIGIT DISC NUMBER
SS "00"

TOP 10 HITS ALWAYS BEING DISPLAYED ABOVE

TOP 10 HITS PRESS  TO PAUSE HIT LISTING • PRESS AGAIN TO ADVANCE TO NEXT HIT

TO CLEAR PRESS  TO CLEAR IF YOU MAKE AN ERROR WHILE SELECTING

PLAY ... 50¢
PLAYS ... \$1
PLAYS ... \$5



QUARTERS

INSERT COINS
HALF DOLLARS OR QUARTERS

or

30 p. ■
50 p. ■
1¢ ■



INSERT COINS

1 PLEASE READ INSTRUCTIONS

Storage and operation of this device is allowed in dry rooms only.

1.1 Transport Damages

If external damage due to transport is noticed, this should at once be recorded on the delivery slip and endorsed by the person making the delivery.

The manufacturer is not liable for damages caused during transport!

1.2 Key

One cabinet key and one cashbox key are taped to the front panel. The other keys are in the cashbox.

Upon opening the cabinet lock on the right side the lid may be lifted fully upwards.

1.3 Transport Devices

Devices for safety and protection during transport have to be removed before operating the phonograph.

Prior to any further transit the safety and protection devices have to be replaced.

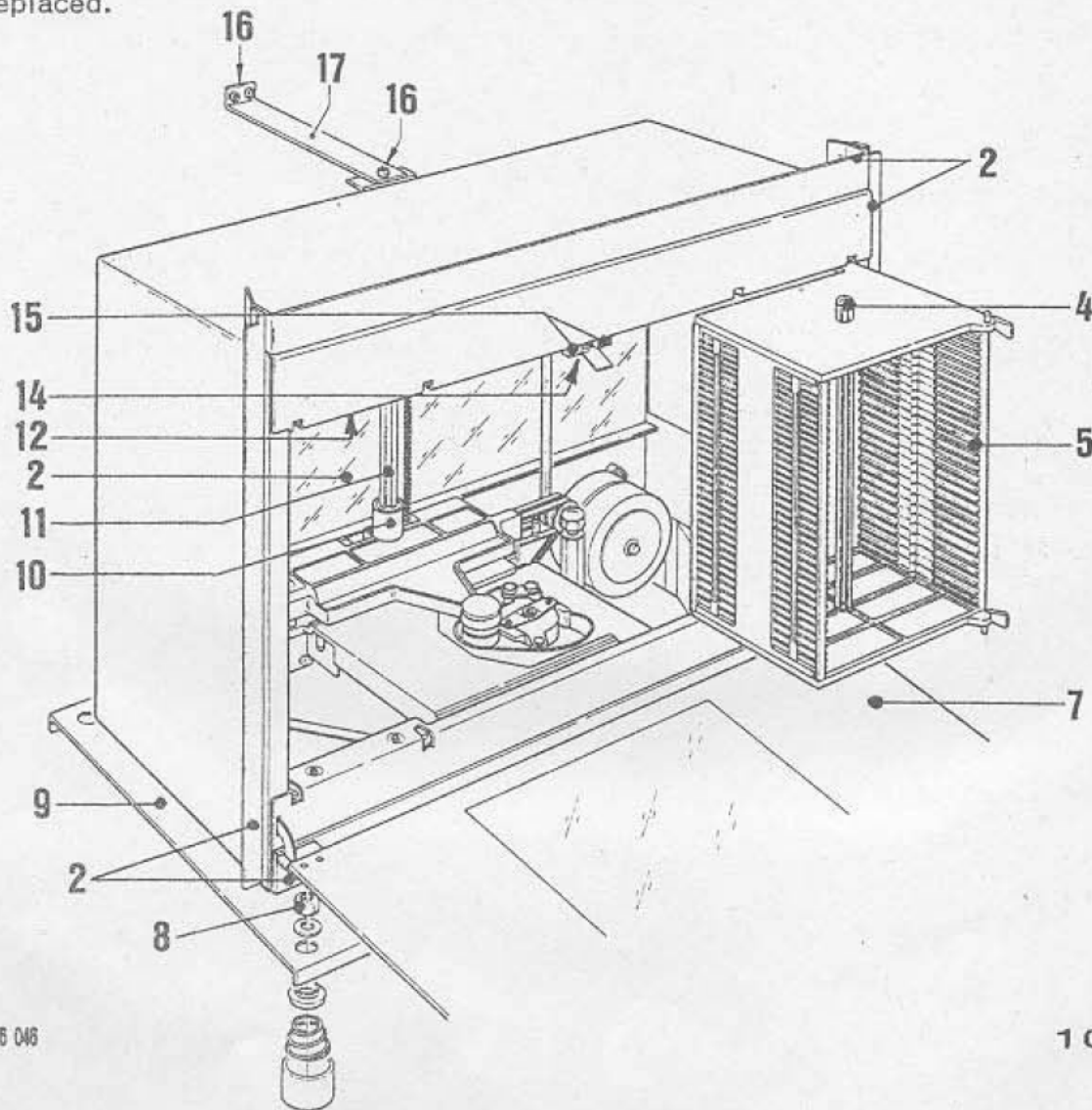

- Take off securing screws (16) and holding bracket (17).
- After loosening fastening screw (14).
If the holding bracket of the PCB's (12) is to be loosened, the fastening screw has to be completely removed.
- Press the service keys (15) to the center and swing out the left and right magazine (5).
- Remove slotted plastic pipe from the lift axle (11), grip the lift close to lift axle (10) and pull up.
- Remove cover from playing mechanism. Remove foam padding (A) or rubber ring (B),

if applicable, which protect the radial motor. Do not insert foam padding on the cable side if safety devices have to be installed for further transport.

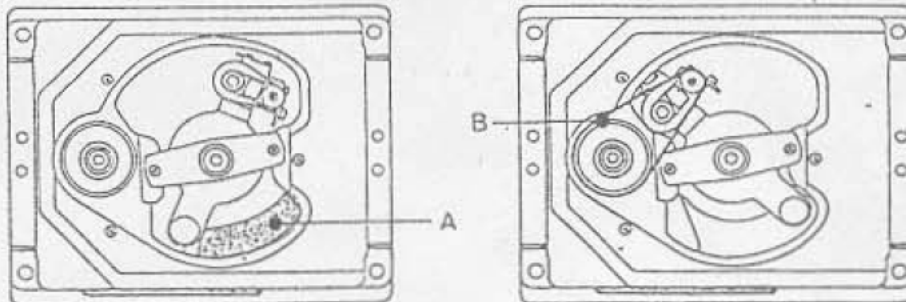

- Loosen CD changer by turning the four nuts (8) so far back from the bottom plate (9) until they are flush with the end of the bolts or completely removed. The changer must be able to move freely.

Keep transport devices in a suitable location in cabinet for later transport!

Information for transport of CD changer:

When exchanging the changer, it may only be transported in the original packaging!

- Remove magazine, push the proper button (15) outwards and remove the unit.
Inserted CD's can be kept from falling out when the plastic pipe from the lift axle as well as a second one from the enclosed package is put through the opening (4) and all CD's of the magazines.
- Remove design parts: Take out front glass (7), take off side trim plates (2).
- Unscrew bottom plate from changer.
- Put safety devices in proper sequence.

1.4 Power Connection

The label on the power cord shows the voltage setting by the factory. For other voltages set voltage required on transformers. Green-yellow of the three-wire power cord must be connected to the ground according to the international safety code. The line cord is located in a box on the rear of cabinet. To pull out the line cord the steel cover has to be removed (4 screws). Put the cable through the respective hole in the cover and put the cover back afterwards.

Check main voltage before connecting!

After plugging in the phonograph turn on the switch located at the rear of the cabinet (fluorescent lights should light up).

1.5 Insert title strips and CD's

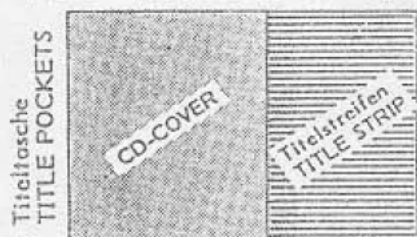

PLEASE OBSERVE!

Equipping of **black** title holders should be done as follows:

Remove title pockets from accessory pack, insert CD covers on the left side and written title strips on the right side in the title pocket - **thicker foil side of title pocket to the outside** - and insert then in black title holder. If the covers are bigger than 120x120 mm, they need to be cut to size - please use only title cover.

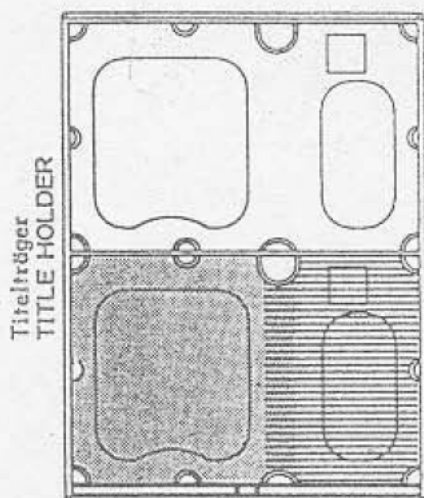

The title program displays are moved by pressing the ← key or the → key on the outside of the machine or the "TL" or "TR" key on the title display PCB.

TITLE STRIP Part-No. 219 185
TITLE COVER Part-No. 212 509

In case of dislocation of title holders due to rough Transportation, please refer to section 9, paragraph 1.4 "Jammed or dislocated title holders".

CD-Changer (Fig. 1): In order to avoid movement of the lift (Attract mode) the cabinet switch has to be pulled out. Now the device is in service mode. In addition, the CD will be returned when it remains on the player after the last track (see also: CD-Changer "Return Holder").

Push button (15) to the center, swing out the magazine, pull out tray and load with CD's. Observe the sequence of the magazine and title strip numbers.

Take care to push in the CD trays until they rest in center and do not hinder the lift.

Note: To take out the magazines push the button (15) to the outside; take out magazines one after the other!

The CD's can be protected against falling out, when transporting loaded magazines, by putting the plastic pipes (4) through the magazines and all loaded CD's.

2 LAYOUT OF UNITS

- 1 OUTPUT TRANSFORMER
- 2 CENTRALE CD
- 3 OUTPUT STAGE
- 4 CONNECTION UNIT
- 5 CROSS OVER NETWORK
- 6 TITLE INDICATION II
- 7 DISPLAY / KEYBOARD
- 8 RECEIVER FOR REMOTE CONTROL
- 9 CONTROL UNIT CD
- 10 COIN MECHANISM
- 11 CD-CHANGER

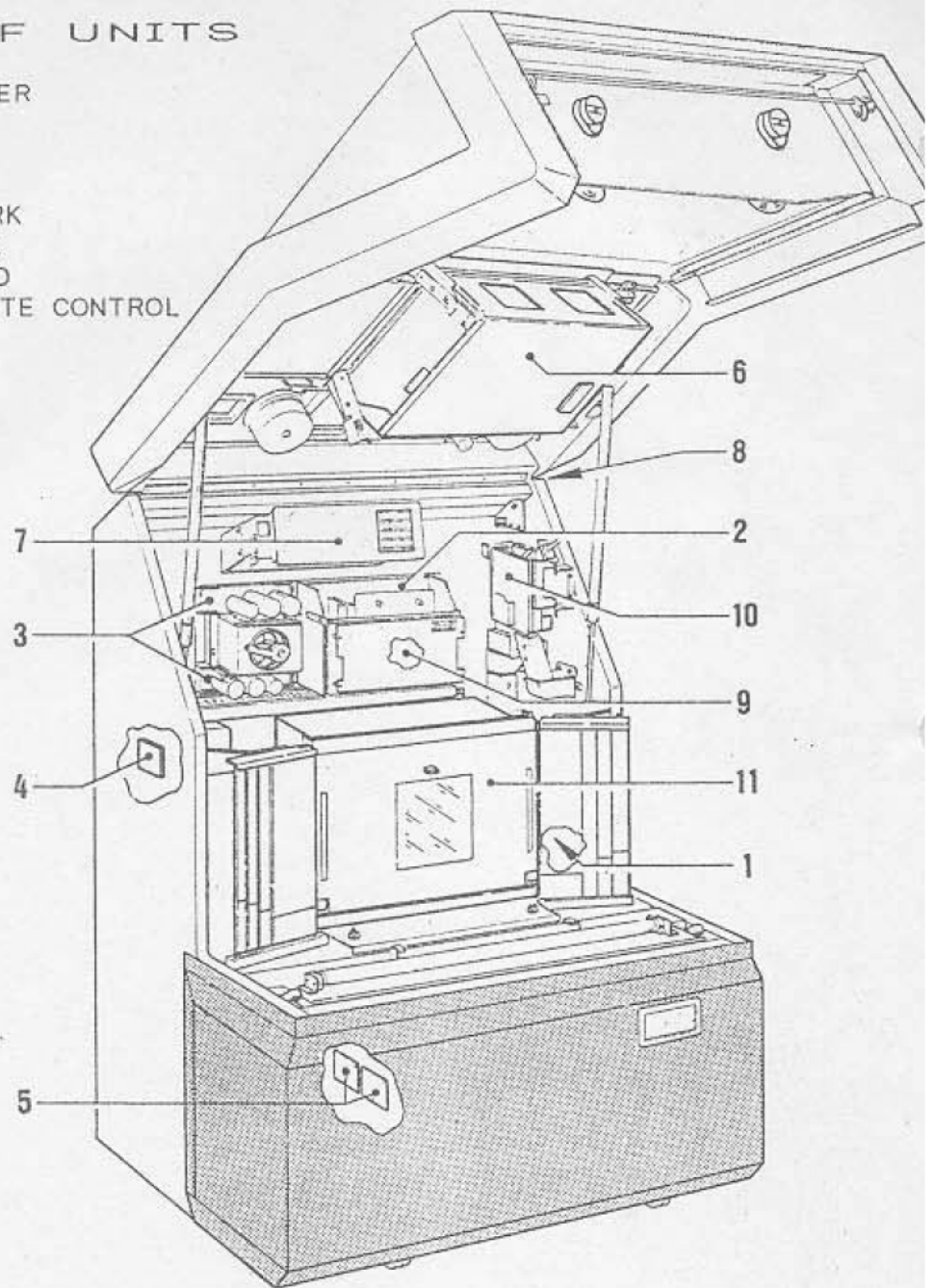

2.1 SELECTOR and DISPLAY PANEL

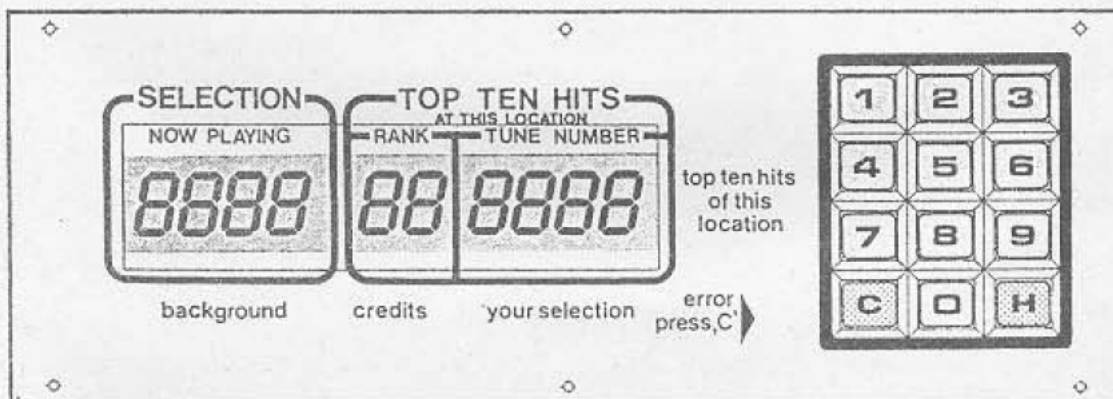

3 SPECIFICATIONS

3.1 Electrical Data

Main voltage: 100-200 V (exchangeable), 50/60 Hz

Power consumption

at stand by 170 W
at play 450 W

3.2 Music Power

2 x 200 watts music power at 2 ohms

3.3 Fuses

Replace fuses only with those of same value!

3.4 Lighting

Lamps	12 V / 2 W
1 fluorescent lamp	16 W / F 28"
2 fluorescent lamps	13 W
2 fluorescent lamps	15 W

3.5 Credit / Cash Input

Maximum credit display is 99.

Price list adjustable individually or as per table.

Free credit adjustment / permanent credit key-operated switch for free credits and background, elect.-mech. cash counter (optional).

3.6 Keyboard

10 number keys	0-9
1 correction key	"C"
1 hit-step key	"H"

3.7 Displays

Display 1 with 4 seven-segment LED's

Display 2 with 2 seven-segment LED's

Display 3 with 4 seven-segment LED's

1 lamp display "10 top hits"

1 lamp display "background"

1 lamp display "credit"

1 lamp display "your selection"

1 lamp display "error, press key "C"

3.8 CD changer

NSM CD changer for maximum 100 CD's, 5- or 3 inch disc player:
Philips CD-2-system with CDM-3-playing unit, servo panel for control of CDM-3.

3.9 Loudspeakers

2 loudspeakers	P 300	4 ohms
2 loudspeakers	P 175	8 ohms
2 loudspeakers	P 135	8 ohms
2 loudspeakers	Skk 10	4 ohms

3.10 Special Features

Integrated microphone preamplifier and connection socket for microphone with paging switch.

Computer-controlled amplifier protection for overload (mismatch).

3.11 Dimensions

Height	56	inch
Width	38	inch
Depth	27	inch

4 LOUDSPEAKER CONNECTION

The ES-IV amplifier supplies an output of 2 x 200-watts music power at 2 ohms per channel.

The impedance of the cabinet loudspeakers is 5,5 ohms, therefore, the cabinet speakers use 2 x 70 watts music power from the amplifier - only one half of the available power.

Therefore, additional loudspeakers can be connected (Fig. 1).

However, in this case the additional loudspeakers connected can not have an impedance of less than 3 ohms because otherwise the amplifier would be "mismatched" and the overload protection would operate.

If loudspeakers with a higher impedance are connected (Fig. 2), a number of speakers can be connected parallel. In that case, a loudspeaker with a higher impedance would naturally be lower in volume.

The ▼ = polarity must be maintained because otherwise bass reproduction would nullify itself.

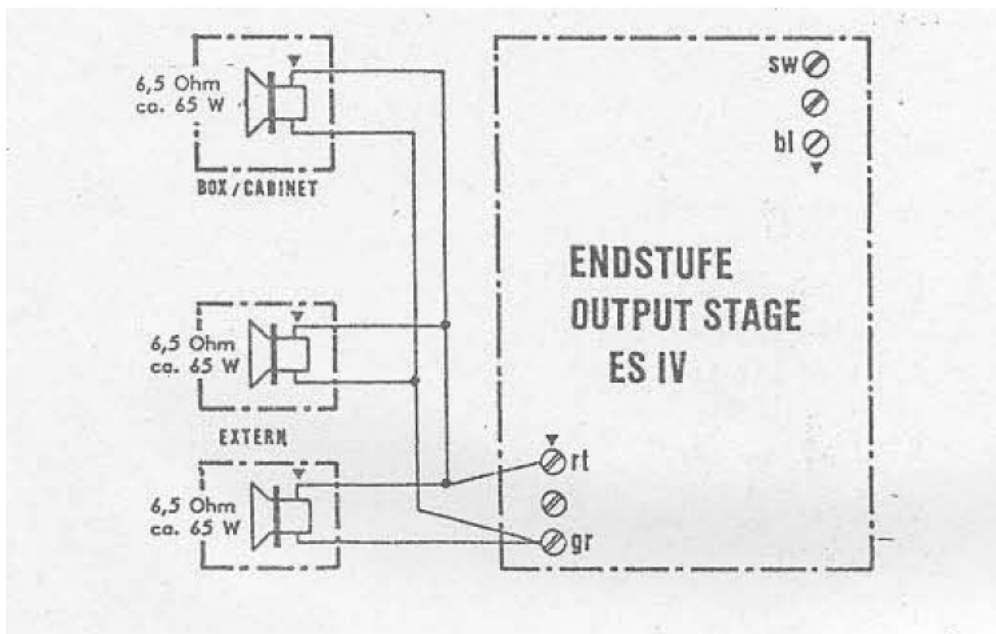
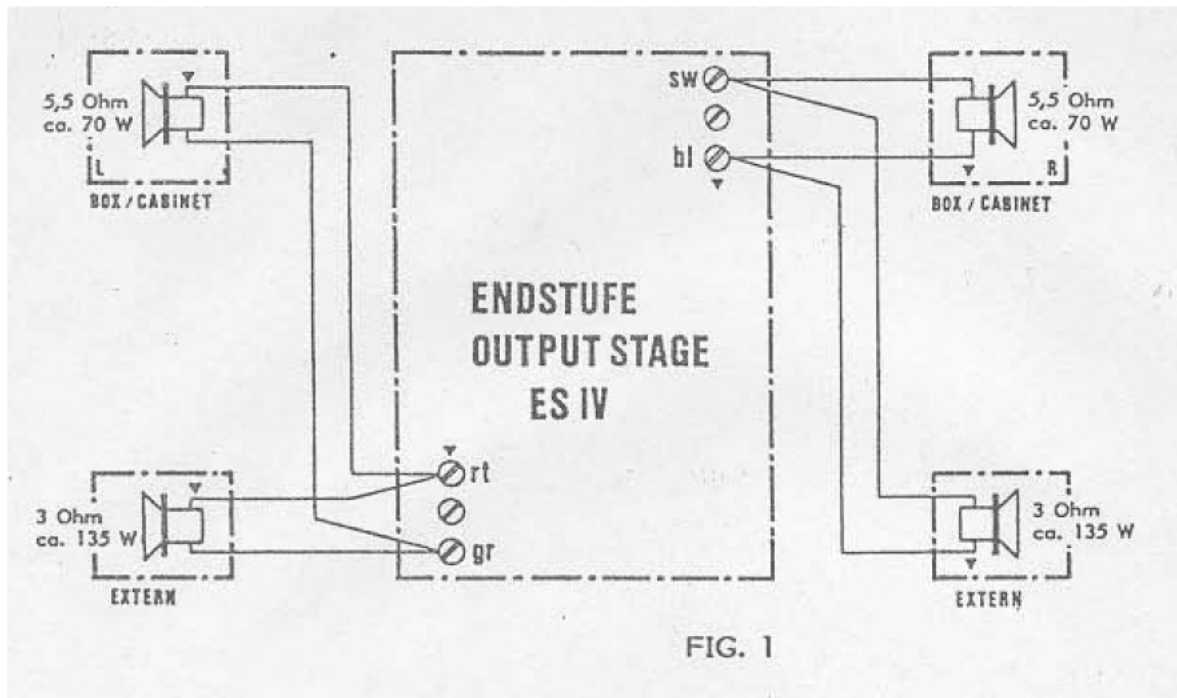

Mono mode; sound system for separate rooms; see Fig. 3.

If the volume is to be controlled independently from 2 rooms, both cabinet speakers can be connected to one channel. The loudspeaker for the other room can then be connected to the free channel. For that a jumper has to be soldered at DR 202 (see cut-out PCB central unit). For this independent procedure a volume control with separate controls is necessary (see remote control).

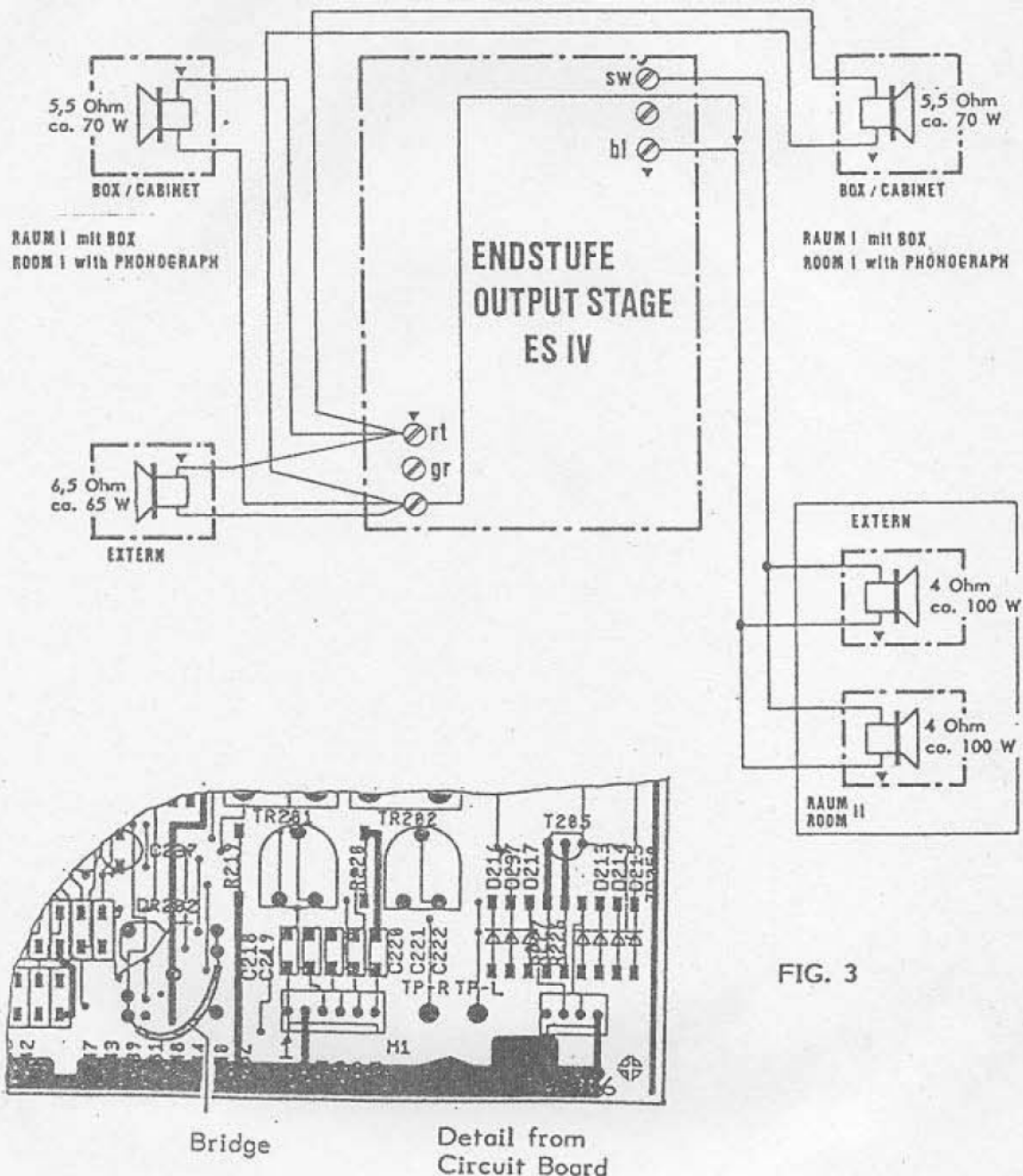

FIG. 3

Additional Loudspeakers and Separate Control

If even more speakers are to be connected whereby the total impedance drops below 2 ohms, an output transformer has to be used (see schematics "loudspeaker connection" and unit description "OUTPUT TRANSFORMER"). Cabinet speakers (Fig. 4) in serial connection result in lower volume!

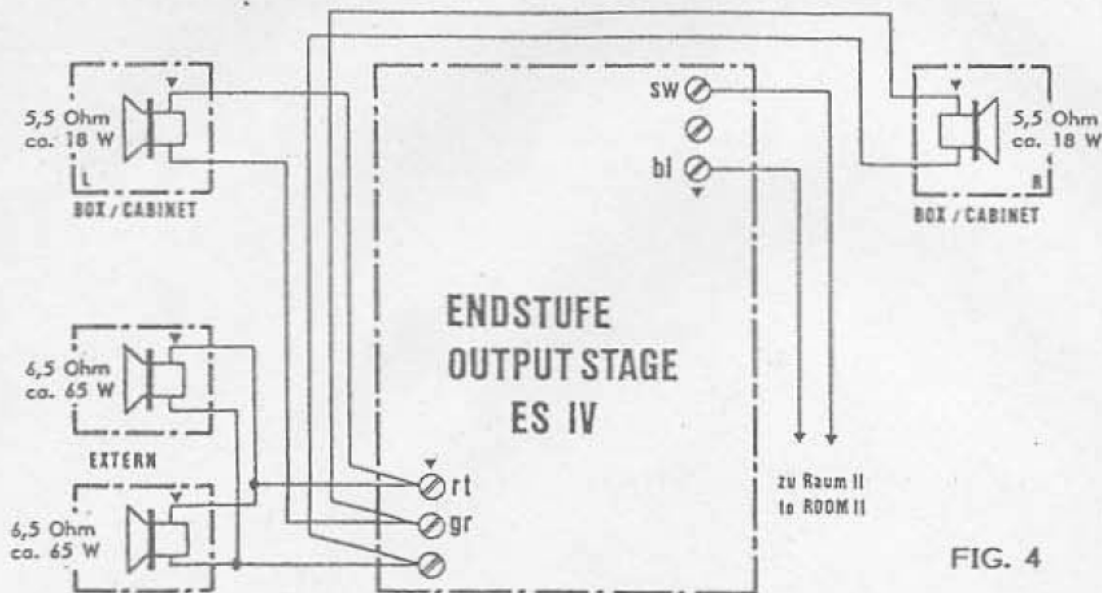

FIG. 4

An auxiliary amplifier can be connected for independent stereo control of other rooms as well as for increased power requirements.

See also unit description "Central Unit", connection of auxiliary amplifier, and "Accessories", tape recorder connection cable or CD-audio connection.

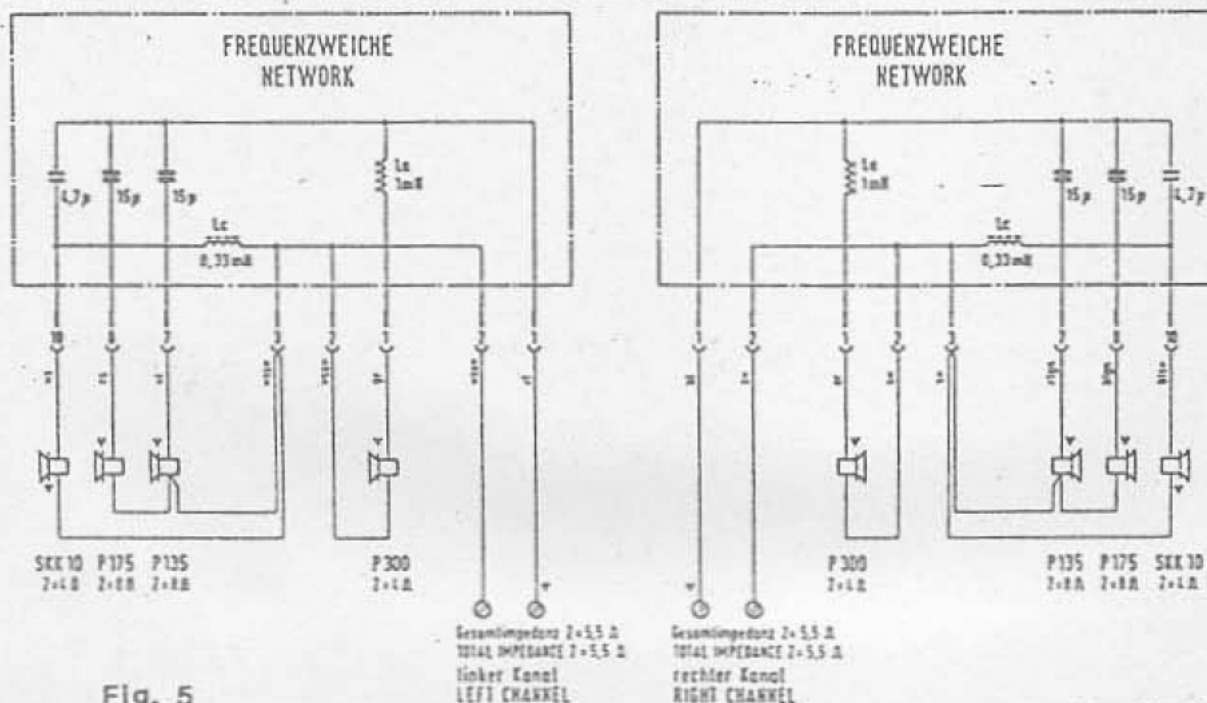

Fig. 5

Verstärker oder Ausgangsübertrager
AMPLIFIER OR OUTPUT TRANSFORMER

Lautsprecher-Kombination
SPEAKER COMBINATION

4.1 OUTPUT TRANSFORMER

Extension Speaker Operation

To avoid a poor sounding phonograph, care must be taken when adding extension speakers. Three requirements must be met:

- 1.) Speakers must be wired so that the power consumed by the phonograph speakers and the extension speakers, including wallethes, does not exceed the amplifier power rating.
- 2.) Extension speakers should produce the desired sound level relative to the sound level of the speakers on the phonograph.
- 3.) All speakers must be connected with the correct polarity.

Several charts have been included to assist you with connecting the extension speakers. Figure 2-10 at the end of this section shows the entire sound system.

70-VOLT-SPEAKER

To avoid prohibitive cable losses on long speaker lines, 70-volt speakers should be used as much as possible.

The power level in the 70-volt speakers is set at each speaker.

Low Impedance 8-Ohm Speakers

Low impedance speakers (8 ohms) can be used when the connecting cable is less than 100 feet (AWG 18) / 0,75 mm².

The loss 100 feet (AWG 18)/0,75 mm² of zipcord feeding one 8-ohm speaker is 15 %. The loss for two 8-ohm speakers is 30 %.

4-OHM SPEAKERS

No more than one 4-ohm speaker should be connected to a speaker line. If several 4-ohm speakers are to be used, each speaker should have its own line.

Do not connect a low impedance speaker to a speaker tap that exceeds the speaker's power rating.

CAUTION:

In any speaker installation, the total speaker load (the sum of all power ratings of all speakers) must not exceed 400 watts Musik Power (2x200 W je Kanal).

SELECTING SPEAKER POWER

General Instructions

This section will lead you through the power and speaker selection process. This process consists of three major steps and several smaller steps. The major steps are:

- 1.) Identifying the extension speakers and computing the extension speaker power.
- 2.) Making the external speaker connections.
- 3.) Determining and selecting the phonograph power.

Step-By-Step Instructions

- 1.) Use a pencil (you may want to revise your figures) to fill in the work sheet on the following pages.

Use this work sheet to help you calculate the amount of power consumed by the extension speakers.

Use table as a guide to help you select which power tap to use for each type of external speaker that you are using.

Place the quantity of stereo speaker in the blank under QTY and multiply the quantity times the power consumption (show stereo speakers as 2 speakers). Place your results in the TOTAL blank.

Table 1

4-OHM Stereo Speakers

	QTY		Total	Connections
Speakers for the 1,8 watt taps:	___ at 1,8 watts each =	___ watts	(0 to 1)	
Speakers for the 7,5 watt taps:	___ at 7,5 watts each =	___ watts	(0 to 2)	
Speakers for the 15 watt taps:	___ at 15 watts each =	___ watts	(0 to 3)	
Speakers for the 30 watt taps:	___ at 30 watts each =	___ watts	(0 to 4)	
Speakers for the 65 watt taps:	___ at 65 watts each =	___ watts	(0 to 5)	
Speakers for the 100 watt taps:	___ at 100 watts each =	___ watts	(direkt to Amplifiere)	
	Total blank 4-Ohm =	___		

8-Ohm Stereo Speakers

	QTY		Total	Connections
Speakers for the 1 watt taps:	___	at 1 watts each =	___ watts	(0 to 1)
Speakers for the 4 watt taps:	___	at 4 watts each =	___ watts	(0 to 2)
Speakers for the 8 watt taps:	___	at 8 watts each =	___ watts	(0 to 3)
Speakers for the 16 watt taps:	___	at 16 watts each =	___ watts	(0 to 4)
Speakers for the 35 watt taps:	___	at 35 watts each =	___ watts	(0 to 5)
Speakers for the 50 watt taps:	___	at 50 watts each =	___ watts	(direkt to Amplifiere)
		Total blank 8-Ohm =	___	

70-VOLT SPEAKERS

70-Volt speakers have a power tap on them or on their associated transformer. Add together all of the 70-volt speaker tap settings and enter that value:

___ watts (A1 to A2)
(B1 to B2)

Combine all speaker's consumptions:

Stereo

4 Ω _____

8 Ω _____

70 Volt _____

Subtract the Grand Total from 400 and write the result in the blank at the end of this line:

Power Available For The Phonograph _____

The Grand Total is the amount of power that the phonograph will need to supply to the extension speakers. This amount must be less than 400 watts. If this amount is not less than 400 watts, you must reduce the power used by the extension speakers to reduce the total power consumed; then recalculate the total power consumed. (andere Klemme anschließen).

When you subtract the Grand Total from 400, you will get the "Power Available For The Phonograph" figure. Be sure to write this value down in the blank because you will not be using it until you have wired all of the extension speakers.

NOTE:

The amplifier may be connected to a load of 400 watts before distortion will begin to increase beyond specification.

The phonograph wires to change are the red (left channel) and the blue (right channel) on the output transformer assembly (see table 2).

Use table 2 as a guide to select the power used by the phonograph. This power should roughly match the amount indicated in "Power Available For The Phonograph" on the previous page.

Table 2

Phonograph Speaker Power

Select the speaker taps that will use up most of the "available Speaker Power".

You may select more power or less phonograph power to suit you phonograph volume preference.

Phono Power *) [W]	Phono Speaker Connections
2,4	Red connects to Left E1, blue connects to Right E1
11,0	Red connects to Left E2, blue connects to Right E2
22,0	Red connects to Left E3, blue connects to Right E3
44,0	Red connects to Left E4, blue connects to Right E4
100	Red connects to Left E5, blue connects to Right E5
140	Red connects to Left direkt Amplifier, blue connects to Right direkt Amplifiere

Do not move the Black wire; it should stay on either the Left or Right E1 terminal.

*) This value is the total for both channels. The power consumption for each channel is one-half of this value.

Check that the phonograph is not overloaded by performing the following four steps:

- A. Make sure that the phonograph and extension speakers are connected to the proper speaker taps.
- B. Set the volume control fully clockwise (maximum volume) and make a selection.
- C. While the music is playing, an acceptable load will allow the OVERLOAD INDICATOR(S) to be off or occasionally flicker in a random manner. If the OVERLOAD INDICATOR(S) are always lit or flicker continuously, the amplifier is overloaded and you must perform step D.
- D. Do this step only if the OVERLOAD INDICATOR(S) came on as described in the previous step. Find the source of the overload (shorted speaker wires or too many speakers on line) and repeat step C.

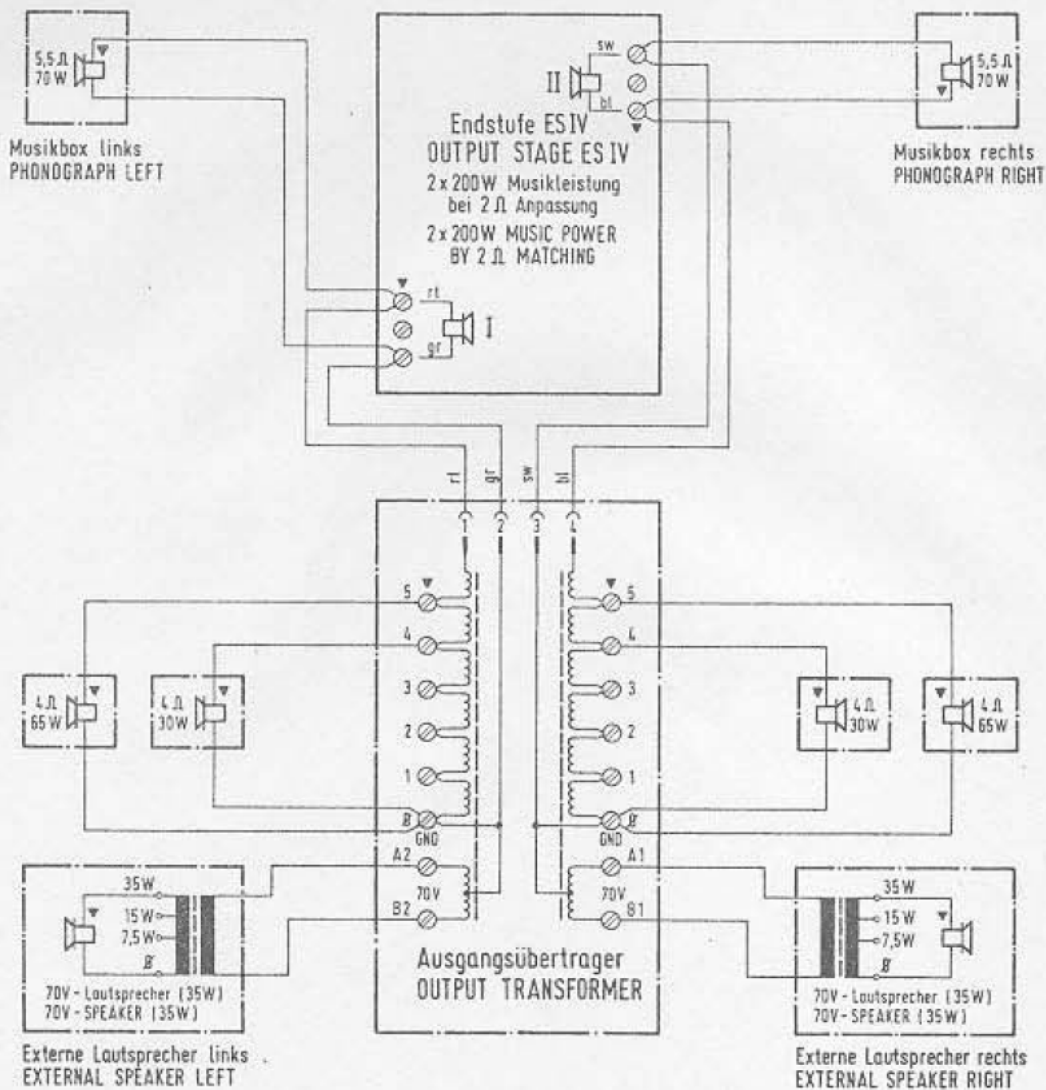

Anschlußschema für Ausgangsübertrager
 CONNECTION DIAGRAM FOR OUTPUT TRANSFORMER

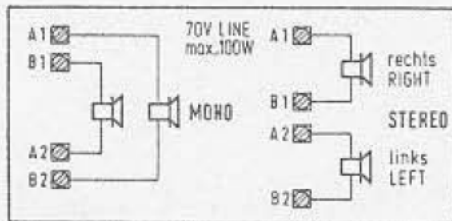

Klemme TERMINAL POSITION	Lautsprecher SPEAKER				
	2 Ω	2,5 Ω	4 Ω	8 Ω	16 Ω
0 - 5	130 W	100 W	65 W	35 W	18 W
0 - 4	60 W	48 W	30 W	15 W	8 W
0 - 3	30 W	24 W	15 W	8 W	4 W
0 - 2	15 W	12 W	7,5 W	4 W	2 W
0 - 1	3,7 W	3 W	1,8 W	1 W	0,5 W

ÄNDERUNGEN IM SINNE DES TECHN. FORTSCHRITTES VORBEHALTEN,
 JEDOCH KEINE NACHRÜSTPFLICHT!
 SUBJECT TO TECHNICAL MODIFICATION WITHOUT OBLIGATION
 TO MODIFY EQUIPMENT ALREADY DELIVERED!



MUSIKAUTOMATEN
 PHONOGRAPHS

ES IV - CD TECHNOLOGY

Lautsprecheranschluß
 SPEAKER CONNECTION

Anschluß für max. Ausgangsleistung
 CONNECTION FOR MAX. POWER OUTPUT

dat	18.10.91	gez	Braun	gezeichnet	<i>[Signature]</i>	geprüft	<i>[Signature]</i>
-----	----------	-----	-------	------------	--------------------	---------	--------------------

UNIT DESCRIPTION

REMOTE CONTROL

FOR NSM-PHONOGRAPHS

EE IV-CD TECHNOLOGY

to
Technical Information, Assy

174 903	SILVER CITY
174 831	SILVER SKY
174 486	FASCINATION
175 274	SOUNDMASTER
175 040	FIREBIRD/COUNTRY
176 046	THE PERFORMER "GRAND"

NSM
Aktiengesellschaft
Saarlandstraße 240
6530 Bingen am Rhein

11

Page 1101-1105

INDEX

- 1 FUNCTION
- 1.1 Infra-red remote control (wireless)
- 1.2 Wired remote control
- 1.3 Installation instructions for infra-red remote control
- 1.4 Volume control (on rear cabinet wall)

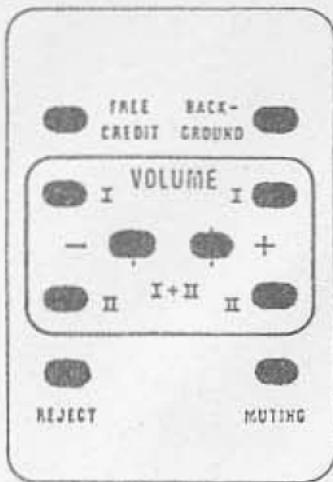

INFRARED REMOTE CONTROL, ASSY.

Part No.	171 808
with sender	217 817
Receiver	173 178
and connection cable (standard)	171 883
Connection cable (5 m)	170 459

REMOTE CONTROL with 5 m cable

Part No.	171 743
----------	---------

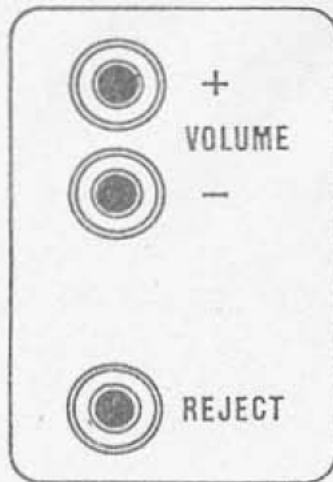

VOLUME CONTROL

Part-No.	170 212
----------	---------

Option: This volume control is a remote alternative to the control installed in the device. (For connections see par. 1.4) The cable has to be extended - any 4 pole cable can be used.

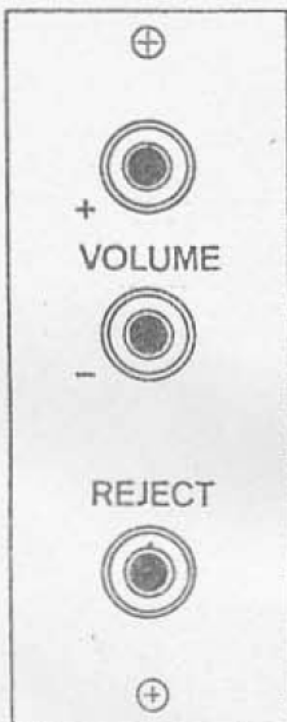

to 1.4

1 FUNCTION

1.1 Infrared remote control (wireless)

The cable of the remote control receiver has to be put into plug ST 205 of the central unit.

Pin 1 supplies the +15 V voltage.

Pin 2 = GND

The commands - as per chart - are fed to the computer inputs via Pins 3 through 6 by switching to ground.

The signals go to the control unit via plug ST 201.

1.2 Wired remote control

For remote controls with cable the plug has to be connected with ST 205 on the central unit (instead of infrared remote control). The corresponding channels (Pins 3 through 6) - as per chart - are connected to GND Pin 2 via the remote control diode linkage.

TASTE / KEY	AUSGANGS-CODE OUTPUT-CODE	STECKER / PLUG ST 205 / PIN
VOLUME - 1	2 / 4	5 / 3
VOLUME + 1	4	3
VOLUME - II	2 / 3	5 / 4
VOLUME + II	3	4
FREE CREDIT	1 / 3	6 / 4
BACKGROUND	1 / 4	6 / 3
REJECT	2	5
MUTING	1	6
VOLUME + (I+II)	3 / 4	4 / 3
VOLUME - (I+II)	2 / 3 / 4	5 / 4 / 3

1.3 Installation Instructions for Infrared Remote Control

The receiver with standard connection cable is mounted onto the back of the cabinet or the back of the hood when a small distance is involved. The top (receiving side) of the receiver should be mounted a little underneath the upper edge of the rear cabinet. Wallboxes and Hide-Away's have to be mounted close to the machine.

If a greater distance has to be bridged or an absorbing ceiling is influencing correct functioning the receiver has to be mounted in such a way on the wall or the ceiling that direct radiating of the manual sender is possible. A connection cable (5 m), Part. No. 170 459, is available for this purpose.

The connection cable of the receiver is put into plug S 205 of the central unit.

SECURING MANUAL SENDER

To protect the manual sender from theft, mount the bracket with two screws onto the back of the sender (see fig.). This way the sender can be secured with a chain.

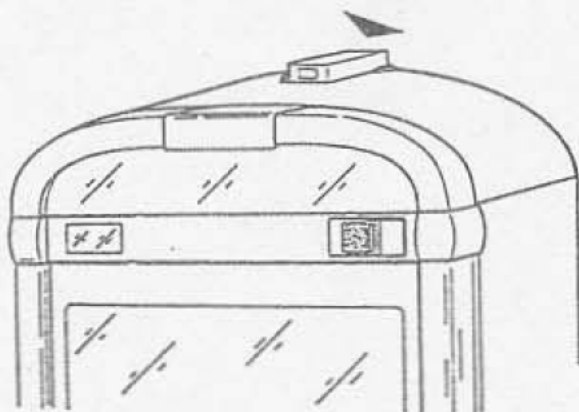

Fig. 1

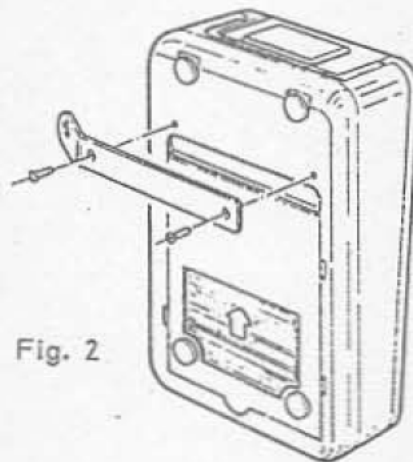

Fig. 2

Manual sender with safety bracket and screws

1.4 Volume Control (On Rear Cabinet Wall does not apply to wallboxes and Hide-Away's).

The connection cable must be put into plug ST 206 of the central unit. When the volume keys are pressed, the computer inputs are switched to GND via the diode linkage D 213-217.

TASTE / KEY	AUSGANGS-CODE OUTPUT-CODE	STECKER / PLUG ST 201 / PIN
VOLUME + (I+II)	3 / 4	6 / 7
VOLUME -(I+II)	2 / 3 / 4	5 / 6 / 7
REJECT	2	5

STATISTIC- AND SERVICE PROGRAMS FOR NSM-PHONOGRAPHS

ES IV-CD TECHNOLOGY

to
Technical Information, Assy

174 903	SILVER CITY
174 831	SILVER SKY
174 486	FASCINATION
175 274	SOUNDMASTER
175 040	FIRE BIRD/COUNTRY

NSM
Aktiengesellschaft
Saarlandstraße 240
6530 Bingen am Rhein

3

Page 301-314

INDEX

- 1 SERVICE PROGRAM
 - 1.1 Statistics program
 - 1.1.1 Popularity beginning with least played title upwards
 - 1.1.2 Popularity beginning with most played title downwards
 - 1.1.3 Reading counters
 - 1.1.4 Erasing counters and credits
 - 1.1.5 Data transfer
 - 1.2 GENERAL SETTINGS
 - 1.2.1 Standard settings
 - 1.2.2 Code for DATA PRINT
 - 1.2.3 Position settings
 - 1.2.4 Free credits
 - 1.2.5 Random discs
 - 1.2.6 Light organ/generator (only for phonographs with LP light generator)
 - 1.2.7 Volumes for normal and background titles
 - 1.2.8 Maximum playing time
 - 1.2.9 Sequence of CD's played
 - 1.2.10 Maximum of tunes played on the same CD
 - 1.2.11 Authorization
 - 1.2.12 Change of key code
 - 1.3 PRICE SETTINGS
 - 1.3.1 Standard settings
 - 1.3.2 Price table (plays/monetary value)
 - 1.4 MONETARY VALUE SETTINGS
 - 1.4.1 Standard settings
 - 1.4.2 Monetary values (for Channels 1 to 5)
 - 1.5 TESTING PROGRAMS
 - 1.5.1 Display test, Display 1 "P60"
 - 1.5.2 Entry test, Display 1 "P60"
 - 1.5.3 Continuous Run 1
 - 1.5.4 Continuous Run 2
 - 1.5.5 Test CD changer
 - 1.5.6 Selection of CD and track numbers
 - 1.5.7 Read-out of errors

1 SERVICE PROGRAM

When opening the cabinet and activating the cabinet interlock switch (pull out plunger), the phonograph is automatically switched from play mode to service mode.

In the service mode the user has available many valuable and easy-to-use aid programs. There are five main sections:

1. Statistical programs which support the reading, evaluating, printing and erasing of all counters (P01 to P12)
2. Programs which permit a standard setting by the manufacturer as well as settings for customers of all machine parameters (P20 to P39).
3. Programs which make possible an individual setting of a price table, but also offer the selection of a standard table out of 20 tables altogether (P40 to P46).
4. Programs which make possible the individual coin value setting for five channels, but also permit programming of one standard setting available for many countries (P50 to P56).
5. Testing programs which support a quick functional test of units as well as locating an error on location (P60/P61).

At delivery the phonograph is "non-coded", e.g. all data and programs are accessible in the service mode. Of course, all confidential data - they are marked in the last column of the following table by an "X" - can be locked via entry of a 4-digit code number (P39).

Short Program

After opening the cabinet and activating the cabinet switch manually, the statistical program "popularity" is automatically turned on. Display 1 shows program step "P01", Display 3 shows the least played CD.

Continue on to the following program steps by pressing "H".

When desiring another program step, press "C", Display 1: "P". After that one can select a program step directly by entering the desired program number and pressing "H".

Return to normal program by pressing "C" twice.

Information (read-out of counters) of certain program steps through entry of code numbers.

Additional functions of certain program steps through entry of a code number and "H".

Standard settings in program steps P20, P40 and P50 through entry of table number and "H" within that program step.

SELECTOR and DISPLAY PANEL

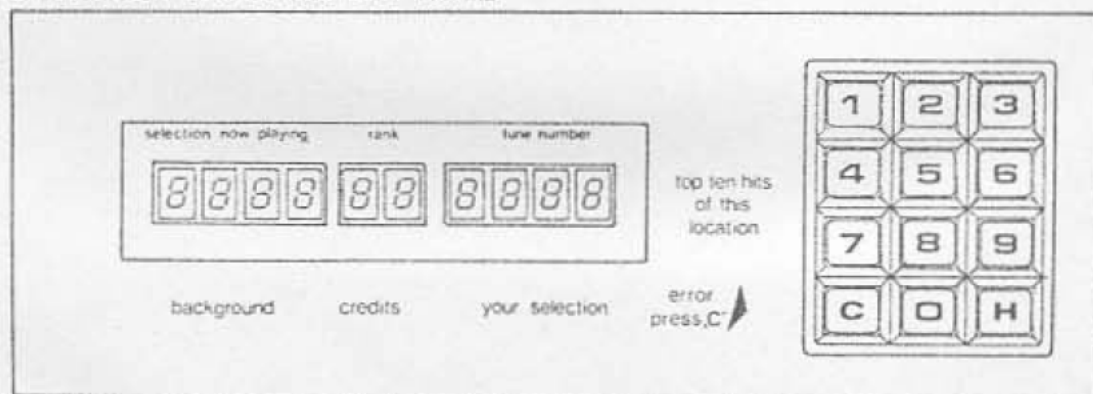

Display panel with displays 1, 2 and 3 as well as 12 button selector

1.1 Statistical program

1.1.1 Popularity-from least played title upward

Display Designation	Remarks	x
PO1 Number of least played CD.	Enter number "0" (is switched on automatically).	
Number of next least played CD, etc. upwards to the most played CD.	Advance with "1".	
Rank of CD displayed.	Enter the number "2". The next display corresponds to the rank of this record. Example display "5" corresponds to the fifth least played record.	
Total of this CD played (max. 255).	Enter number "3".	If a pop. counter is greater than 200 at "power off", all counters are divided by 2 (normalized). An "r" appears on display 2 until the counters are reset (the pop. dis- play is relative).
Information on a certain CD.	Enter the number "4", the desired CD number and "H". The desired information on this CD can be called up as described previously with the keys "1" through "3".	

1.1.2 Popularity, from best title upwards

PO2 Number of most played CD.	Enter number "0" (is switched on automatically).	
Number of next most played CD etc. down to the least played CD.	Advance with "1".	
Rank of CD displayed.	Enter the number "2". The next display corresponds to the rank of this record. Example display "5" corresponds to the fifth least played record.	
Total of this CD played (max. 255).	Enter number "3":	If a pop. counter is greater than 200 at "power off", all counters are divided by 2. An "r" appears on display 2 until the counters are reset. Get actual popularity, multiply all by 2.
Information on a certain CD.	Enter the number "4", the desired CD number and "H". The desired information on this CD can be called up as described previously with the keys "1" through "3".	

1.1.3 Counter read-out

Display Designation	Remarks	x
P03 Cash balance in monetary (as programmed by the settings in P51 through P55). 5 digits.	Enter number "0" (is switched on automatically).	x
Cash balance-accumulated-5 digits.	Enter the number "1". Value shown must be multiplied by 100 to get total monetary units.	x
P04 Play counter.	Enter number "0" (is switched on automatically).	x
Play counter, accumulated.	Enter number "1".	x
P05 Number of selected title.	Enter number "0" (is switched on automatically).	x
P06 Number of album selections.		x
P07 Number of free credits.		x
P08 Number of background titles.		x

1.1.4 Counter and credit reset

P10 Total reset of popularity (P01, P02) the HIT-parade, the counters P03 through P08 and credits.	Enter number "1" and "H".	x
Resetting the popularity (P01, P02) and HIT-parade.	Enter number "2" and "H".	
Resetting the counters (P03 through P08).	Enter number "3" and "H".	x
Cancel credits.	Enter number "4" and "H".	

1.1.5 Data transfer

P11 Data transfer and memory (storage) with the DATA PRINT. (from Progr.-Index 004)	Plug DATA PRINT into "Service Socket" of control unit. Enter Code "1" and "H". Counters (P03-P08) and popularity will be transferred. Display 3 "E0" appears in case of error during data transfer. Also see description DATA PRINT.	
P12 Transfer to DATA PRINT. Note: If phonograph is "coded", only the decoded values are printed out unless the code number is entered. (from Progr.-Index 003)	Plug printer into the "service socket" on the control unit. Enter "1" = counters (P03 through P08) or "2" = counters (P03 through P08), settings (P21 through P37, P39) or "3" = counters (P03 through P08), popularity (P01, P02) or "4" = counters, settings, popularity. If overflow has taken place, the popularity is relative, the multiplying of overflows is printed out also. If the printer does not operate, "E0" appears on display 3.	

1.2 Specific Settings

1.2.1 Standard Settings

Display Designation	Remarks	x
P20	Programming of steps P21 through P39 (for factory setting see table 1).	x

Standard table for specific settings in program step P20.

The following table shows the basic setting (factory setting) of the phonograph.

Tab.-No. Result in the individual program step:

P21: 0000 = unit code (for recording device)	
P22: 0024 = maximum choice CD/track (100 CD's/24 tracks)	
P23: 200 = free credits	
P24: 15 = interval for random play in minutes	
P25: 10 = Number of CD's for background	
P26: 1105 = light organ during standby	} Only for models with light organ / luminous effects
P27: 1000 = light organ during play	
P28: 3116 = maximum Volume of both channels for coin-selected titles and background-CD	
*)P30: 0 = No limit of playing time for a title	
*)P31: 0 = Playing in sequence of selection	
*)P32: 0 = No limit on playing titles on the same CD	
P39: 0000 = code number (data and program settings not coded)	

*) from Progr.-Index 004

1.2.2 Code number for DATA PRINT

P21	Machine code number for DATA PRINT	Enter code number between "0" and "9999" as well as "H".	x
-----	------------------------------------	--	---

1.2.3 Position Settings

P22	Number of maximum choice CD's and tracks	Enter desired number between "0101" and "0099" as well as "H". CD-Nr. 00 = 100. Example for 100 CD's / 24 tracks: "0024".	
-----	--	--	--

1.2.4 Free credits

P23	Number off free credits.	Enter desired number and "H". "0" to "199": The number of free credits set can be released individually by the FREE CREDIT key on remote control. "200": An unlimited number of free credits can be set and released by the FREE CREDIT key on remote control. "201": The phonograph is continuously switched to "free credits" when the FREE CREDIT key is pressed (Credit Display "99"). The phonograph is switched back to operating mode when the FREE CREDIT key is pressed again.	x
-----	--------------------------	--	---

1.2.5 Random title and Background

Display Designation	Remarks	x
P24 Time interval for random title.	Enter desired time interval between "0" and "255" minutes, followed by "H". (No random titles are played when "0" is entered).	x
P25 Number of background music CD.	Enter desired number between "0" and "100", followed by "H". Background starts counting downwards starting with maximum number of CD's up (P22) to set number of background positions. With setting "0" no background operation.	

1.2.6 Light Console / Light Organ (Only for models with light organ / luminous effects)

	A	B	C	D		x
P26 Luminous effects for "stand by mode" or	0	0	0	1	Setting "A" corresponds to the switching characteristic: "0"-slow to "1"-fast.	x
P27 Luminous effects for "play mode"	↓	↓	↓	↓	Setting "B" corresponds to speed of intervals (0-3).	
	1	3	1	5	Setting "C-D" corresponds to the various types of light effects "1" through "15". Complete entry with the "H"-button.	
P26 Continuous light for "stand by mode" or	0	0	0	0	Setting "B" corresponds to the desired brightness ("0" through "3").	x
P27 Continuous light for "play mode"	↓				Complete entry with "H"-button.	
	3					
P27 Light organ in "play mode".	1	0	0	0	Setting "B" is for the desired basic brightness ("0" through "3").	x
	↓				Complete entry with the "H"-button.	
	3					

1.2.7 Volumes for Regular and Background Music

P28 Maximum volume.	Enter two digits each for desired maximum volume of normally chosen and background titles as well as "H". e.g.: 31 24	x

1.2.8 Maximum Playing Time

P30 Maximum playing time for a title (from Progr.-Index 004)	Enter desired time in minutes between 0 and 99 and then press "H". With "0" no limit of playing time.	x
--	--	---

1.2.9 Sequence of CD's playing

P31 Sequence of CD's playing (from Progr.-Index 004)	Enter Number 0, 1 or 2 then press "H". 0 = in sequence of selection (FIFO) 1 = in numerically increasing sequence 2 = random sequence	x
--	--	---

1.2.10 Maximum of tunes played on the same CD

Display Designation	Remarks	x
P32 Maximum of tunes played on the same CD (from Progr.-Index 004)	Enter desired maximum number of tunes played and then press "H". With "0" no limit.	x

1.2.11 Authorization

P38 Authorization.	Enter correct code number and "H". Each of the four digits is confirmed by "P". After closing with "H" "PPPP" is shown and the operator is thereby given authorization. Only the correct code number enables access to protected data. After closing of cabinet or going back to regular program by pressing "C" twice, the programs are protected again.	
---------------------------	---	--

1.2.12 Code number

P39 Code number.	Changing of code number is only possible when operator has been authorized in program step P38. Enter new code number and "H". Each digit is confirmed after entry with "P". After closing with "H" "PPPP" is shown. Possible entries between "0000" and "9999". If "0000" is programmed, the machine is not protected and access to all programs is possible without authorization. A programmed code number is not shown anymore, so please remember your code number!	x
-------------------------	--	---

1.3 PRICE SETTINGS

1.3.1 Standard Settings, from Progr.-Index 004

P40 Programming of the program steps P41 through P46 (Standard setting).	Enter corresponding table No. and "H". If values deviating from those in the table desired, they can be changed according to the following program steps (P41 through P46).	x
---	--	---

Standard settings for plays per monetary value in program step P40. The result of the programming of a table ("0" through "20") shows the number of plays per monetary value allocated to the program steps P41 through P46. The monetary values are programmed in monetary value units as they are set in P50 through P55; example table 17, P41: If no bonus is to be given for a high monetary value, it is sufficient to program only the small monetary value, the total of the small values results in the larger value; example table 17: 1 x 25 c = 1 play + 100 c = 7 plays.
Standard settings for P46 = "0".

Table- No.	Display of Program Number					Remarks/ as set by the factory
	P41 Sp/Gw	P42 Sp/Gw	P43 Sp/Gw	P44 Sp/Gw	P45 Sp/Gw	
0	00 000	00 000	00 000	00 000	00 000	no coin conversion in this setting.
1	01 050	01 050	01 050	01 050	01 050	New Zealand 1 play = 50 c (NZ)
2	01 020	01 020	01 020	03 050	03 050	Belgium 1 play = 20,- Bfr 3 plays = 50,- Bfr (B)
3	01 005	01 005	03 010	03 010	07 020	If desired, please adjust 1 play = 5,- 3 plays = 10,- 7 plays = 20,-
4	02 050	02 050	05 100	05 100	12 200	Austria 2 plays = 5,- öS 5 plays = 10,- öS 12 plays = 20,- öS (A)

5	02 010 02 010 05 020 05 020 12 050	Germany	2 plays = 1,- DM 5 plays = 2,- DM 12 plays = 5,- DM	(D)
6	01 050 01 050 01 050 03 100 03 100	USA	1 play = 2x 25 c 3 plays = 4x 25 c	(USA)
7	02 010 02 010 02 010 12 050 12 050	Norway	2 plays = 1,- Kr 12 plays = 5,- Kr	(N)
8	01 010 01 010 03 020 03 020 03 020	Venezuela	1 play = 1,- Bol 3 plays = 2,- Bol (7 plays = 5,- Bol)	(YV)
9	01 010 01 010 03 020 03 020 10 050	Ireland	1 play = 10 p 3 plays = 20 p 10 plays = 50 p	(IR)
10	03 010 03 010 07 020 07 020 18 050	Switzerland	3 plays = 1,- sfr 7 plays = 2,- sfr 18 plays = 5,- sfr	(CH)
11	01 030 01 030 02 050 02 050 05 100	United Kingdom Denmark	1 play = 30 p 2 plays = 50 p 5 plays = 1 £	(GB) (DK)
12	01 020 01 020 01 020 03 050 03 050	Jugoslavia (Din) Finland (mk)	1 play = 2x 1,- 3 plays = 5,-	(TU) (SF)
13	01 020 01 020 03 050 03 050 07 100	Union of South Africa France	1 play = 20 c 3 plays = 50 c 7 plays = 1,- R	(SAU) (F)
14	01 040 01 040 02 060 03 080 04 100	Australia	1 play = 2x 20 c 2 plays = 3x 20 c 3 plays = 4x 20 c 4 plays = 1 Dollar	(AUS)
15	01 025 01 025 01 025 01 025 01 025	Canada Dutch Antilles	1 play = 25 c 4 plays = 1 NAF	(CAN) (NA)
16	01 025 01 025 01 025 05 100 05 100	Spain (pts)	1 play = 0,25 5 plays = 1,-	(E)
17	01 050 01 050 03 100 03 100 18 500	USA	1 play = 50 c 3 plays = 1 \$ 18 plays = 5 \$	(USA)
18	01 100 01 100 03 250 03 250 07 500	Netherlands	1 play = 4x 25 c 3 plays = 2,5 hfl 7 plays = 5 hfl	(NL)
19	01 100 01 100 03 200 03 200 05 300	Japan	1 play = 100 Yen 3 plays = 2x 100 Yen 5 plays = 3x 100 Yen	(J)
20	01 040 01 040 01 040 03 100 03 100	Italy	1 play = 2x 200 L 3 plays = 2x 500 L	(I)

1.3.2 Price List (Number of Selections/Monetary Value)

Display Designation	Remarks	x
P41 Number of selections per coin (smallest value).	Enter desired number of plays coin (smallest value) and "H". Entry sequence: 2 digits for number of plays, 3 digits for corresponding coin e.g. 01 020 correspond to one play for 20 pence. Largest programmable number of plays up to 63, price list from 005 to 995.	x
P42	Note: All five program steps must be programmed with the price classes in the sequence or their priority. For less than 5 price classes program more than once or set to "00 000".	x
P43 Operating display are		x
P44 analogous to program		x
P45 step P41		x
P46 Number of required credits for one album.	Enter desired number and "H". At "0" no album selection allowed.	x

1.4 MONETARY SETTINGS

1.4.1 Standard Settings

P50 Programming of the program steps
P51 through P55 (Standard setting).

Enter corresponding table and "H".
If values other than those in the table are desired,
they can be changed according to the following program
steps (P51 through P55).

The monetary value settings in the individual program steps are associated with the corresponding coin channel:
P51 for channel 1; P52 for channel 2, etc. to P55 for channel 5. This table shows the coin values for the
corresponding channel in the currency of the columns P51 through P55.
Standard setting of P56 = "0".

Table- No.	Display of Program Number					Remarks/ as set by the factory
	P51 (Channel 1)	P52 (Channel 2)	P53 (Channel 3)	P54 (Channel 4)	P55 (Channel 5)	
0	000	000	000	000	000	no coin conversion in this setting
1	010 1,- DM 1 Bol 1,- sfr	050 5,- DM 5 Bol 5,- sfr	020 2,- DM 2 Bol 2,- sfr	000 -,- -,- -,-	000 -,- -,- -,-	Germany Venezuela Switzerland (TY) (D) (CR)
2	050 5 S	200 20 S	100 10 S	000 -,-	000 -,-	Austria (A)
3	020 200 L	010 100 L	050 500 L	000 -,-	000 -,-	Italy (I)
4	000 -,- -,- -,-	050 5 mK 5 Kr 5 Din	010 1 mK 1 Kr 1 Din	000 -,- -,- -,-	000 -,- -,- -,-	Finland Norway Jugoslavia (N) (SF) (TU)
5	025 25 c	250 2,5 hfl	100 1 hfl	000 -,-	000 -,-	Netherland (NL)
6	000 -,-	100 1,- NAF	025 0,25 NAF	000 -,-	000 -,-	Netherland Antillen (NA)
7	000 -,-	020 20 Bfr	005 5 Bfr	000 -,-	000 -,-	Belgium (B)
8	010 1 Fr 1 dkr	050 5 Fr 5 dkr	100 10 Fr 10 dkr	000 -,- -,-	000 -,- -,-	France Denmark (DK) (F)
9	020 20 p	050 50 p	010 10 p	000 -,-	000 -,-	United Kingdom/ Ireland (IR) (GB)
10	010 10 c	050 50 c	025 25 c	000 -,-	000 1 Dollar	USA (USA)
11	000 -,-	025 25 c	000 -,-	000 -,-	100 1 Dollar	Canada (CAN)
12	020 20 c	100 1 R	050 50 c	000 -,-	000 -,-	Union of South Afrika (SAU)
13	100 1 Dollar 100 Yen	050 50 c 50 Yen	020 20 c 20 Yen	000 -,- -,-	000 -,- -,-	Australia Japan (J) (AUS)
14	000 -,-	025 25 pts	100 100 pts	000 -,-	000 -,-	Spain (E)

Monetary setting for electr. Coin Acceptor see chapter 10,
 Monetary settings

Table- No.	Display of Program Number					Remarks/ as set by the factory
	P51 (Chan 1)	P52 (Chan 2)	P53 (Chan 3)	P54 (Chan 4)	P55 (Chan 5)	
15	100 10 Fr 1 £	020 2 Fr 20 p	010 1 Fr 10 p	050 5 Fr 50 p	000 -,- -,-	France United Kingdom (GB) (F)
16	050 5,- DM	010 1,- DM	000 -,-	020 2,- DM	000 -,-	Germany (D)
17	050 5,- sfr 500 L 50 c	010 1,- sfr (100 L)	005 1/2 sfr (50 L) 5 c	020 2,- sfr 200 L 20 c	000 -,- -,-	Switzerland Italy New Zealand (I) (CH) (NZ)
18	100 10 dkr (neu)	050 5 dkr	010 1 dkr	100 10 dkr (alt)	000 -,-	bei 4-Channel (1 A) Denmark (DK)
19	200 20 S	050 5 S	010 1 S	100 10 S	000 -,-	Austria (A)
20	025 25 c	250 2 1/2 hfl	500 5 hfl	100 1 hfl	000 -,-	Netherland (NL)

1.4.2 Monetary Values (Allocated to coin channels 1 through 5)

Display	Designation	Remarks	x
P51	Coin value channel 1.	Monetary Setting for electr. Coin Acceptor see chapter 10,	x
P52	Operation and display		x
P53	are analogous to		x
P54	program step P51.		x
P55			x
P56	Bonus credits for bills.	Enter desired number and "H". When a dollar bill is inserted (Channel 5/P55), the programmed value is added to the credit.	x

1.5 TEST PROGRAMS

The displays in this program step acts as test aids for testing the phonograph.

In the event of a malfunction the defective unit can be determined or a malfunction resulting from incorrect settings can be recognized in a simple manner with the aid of these tests. Certain displays are aids for the adjustment of the playing mechanism.

Switch on test program: Open cabinet lid pull out interlock cabinet switch

Display 1 shows "P01", press letter "C".

Display 1 shows "P".

Press number 60 and "H", Display 1 shows "P60".

1.5.1 Display Test, Display 1 "P60"

This program tests the lights and displays on the display circuit board. After starting "F1" (first function test) appears on display 2.

The test is run through in steps: 1. All 5 display lights together.

2. The digits are switched on one after another individually with "8".

3. The display lamps 1 through 5 individually.

4. Displays together, running through the numbers "0" through "9".

The "F1" is displayed for approx. 2 seconds before the test repeats, itself.

Designation	Remarks
Display test -continuous test-	Enter "1" and "H". Display 2 "F1".
Stop test sequence.	Enter "H". The light "10 top hits" comes on.
Continue test sequence.	Enter "H" again. The light "10 top hits" goes off.
Terminate test.	Enter "C" once, display 1 "P60" or actuate cabinet switch, the unit returns to the regular program.

1.5.2 Input Test, Display 1 "P60"

In the following test the functions of all entries of Input Ports 1-6 can be tested:

Port 1, Port 2 : Control Unit

Port 3 : Keyboard (Display Board)

Port 4, Port 5 : Pickup Driver

Port 6 : Title Indication

Every input change is shown on the display as follows:

Input Test Enter "2" and "H", Display 2 "F2" (second function test).

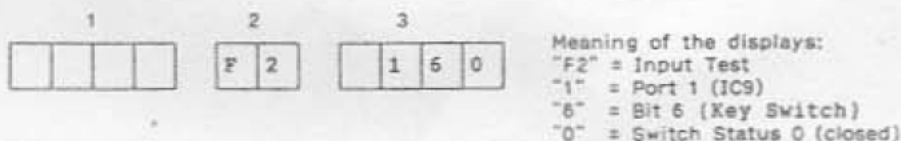
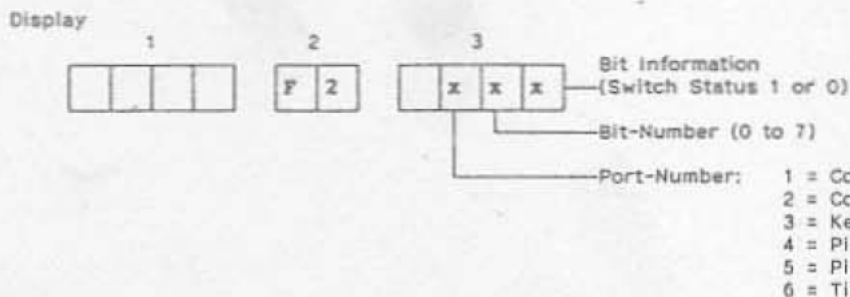

Instruction: The accuracy of the inputs from the keyboard can be checked due to the entry connections simply by selecting a title!

Terminate test. Enter "C" 1, display "P60" or actuate cabinet switch, the phonograph returns to the normal program.

1.5.3 Continuous Run I

The machine is switched to continuous run. Now every CD is played continuously for 16 sec. beginning with the first selection. All errors of the CD changer or CD player are registered.

Continuous Run 1 Enter "3" and "H", Display 2 "F3".
After that select the CD with which to begin.



Terminate test. Actuate housing switch.

1.5.4 Continuous Run 2

The machine is switched to continuous run. All selected titles are played for 16 sec. All errors of the CD changer or player are registered.

Continuous Test 2 Enter "4" and "H", Display 2 "F4".
The select any title.

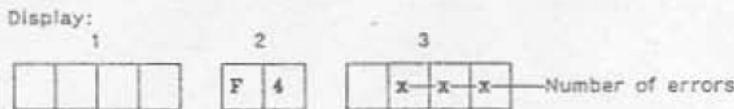

Terminate test. Actuate housing switch.

1.5.5 CD changer Test

All functions of the changer can be tested individually.

CD changer test Enter "5" and "H", Display 2 "F5".

Input	Function
1	CD-Player, Start/Stop
2	Lift, upwardw
8	Lift, downwards
4	Grip left
6	Grip right
5	Return holder
0	Stop lift at magazine space
3	*) Motor steps, upwards (per 0,5 mm)
9	*) Motor steps, downwards (per 0,5 mm)

Keep in mind the code numbers for the individual changer functions as per the following keyboard illustration:

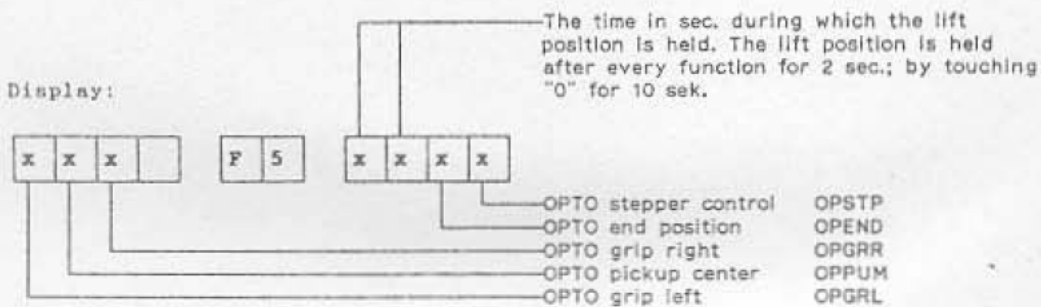
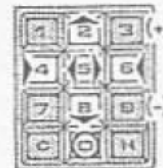

Meaning of displays: OPTO lit up = "0", OPTO darkened = "1".

Terminate test. Actuate housing switch.

*) from Progr.-Index 004

1.5.6 Track selection of CD test records

P61 Track selection of CD test records (more than 15 tracks per record).	Select the required CD record and track number and press "H". e.g. 0123 - Disc 01, Track 23. The selected title will be stored and played after returning to play mode.
---	---

1.5.7 Read-out of errors

P62 Error code of last error (see descr. error displays).	Enter "0". (Is automatically switched on).
Error code of previous errors (see descr. error displays).	Advance with key "1". Up to max. 10 errors.
At error code 6x no. of CD at which error occurred. At error code 9x no. of cover at which error occurred.	Enter "2".
Time since power on or start of test P60/3 or P60/4 when error occurs.	Enter "3". Display in hrs., min.
Cancellation of stored error code.	Enter "4", "1" and "H".

UNIT DESCRIPTION

TITLE INDICATION II FOR NSM-PHONOGRAPH

ES IV-CD TECHNOLOGY

to
Technical Information, Assy

174 903	SILVER CITY
174 831	SILVER SKY
174 486	FASCINATION
175 274	SOUNDMASTER
175 040	FIRE BIRD/COUNTRY

NSM
Aktiengesellschaft
Saarlandstraße 240
6530 Bingen am Rhein

9

Page 901-911

1 FUNCTION

1.1 PCB Title display

The PCB is connected to the serial interface and +5 V of the control unit via ST 1. +15 V and +14 V are also conducted via ST 1. The constant voltage of +15 V supplies motors and opto couplers.

Shiftregister IC 2 is the output port for motor driver IC 3, which controls the motor for stacker movement (MO MOV) and the gripper motor (MO GR).

Shiftregister IC 1 is the input port for opto couplers and push buttons. Light barriers GRL and GRR control the endposition of the gripper (carrier). MOV1, MOV2 and MOV3 supervise various positions during the stacker movement. Any blocking will be recognized and displayed by error code Er 9x.

Pushbuttons TL and TR in the PCB are service keys for moving title holders.

They are identical with pushbuttons (←) and (→) on the front of the phonograph.

1.2 Movement of title holders

By pushing the keys "left" respectively "right" two title holder will be moved into the corresponding direction (from program index 08).

A complete movement consists out of following phases: If i.e. the key "left" is pushed, at first the position of the gripper will be checked and -if required- the front gripper positioned in front of the right hand stack. Both stacks are level. Now the right stack moves to the front while the left one moves back simultaneously until the grippers enter the carrier slots of the corresponding title holders. Then the grippers move the title holder to the other side. In the final position the right hand stack will be moved forward while the left hand stack will be moved backward until they are level. The grippers will be brought back to their starting position. In case of a limitation of selectable CD's via service step P22 only the corresponding title holders will be shown. A movement to the right beyond the highest covernumber as well as to the left below covernumber 1 is not possible.

1.3 Exchange of defective title holders

When defective title holders can still be driven to the front by the motor, the exchange of the holder should be performed there.

For removal, the center of the title holder has to be bent slightly forward until it jumps out of the top guide. The insertion of the new title holder works accordingly.

1.4 Jammed or dislocated title holders

When the transportation by motor is impossible due to jamming, all title holders in front of the jamming location have to be removed. After correcting the problem the title holders have to be inserted in the same sequence (Fig. 1).

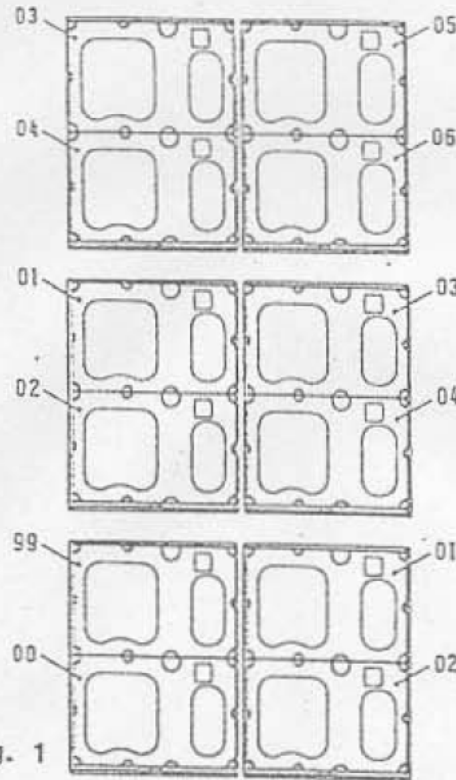
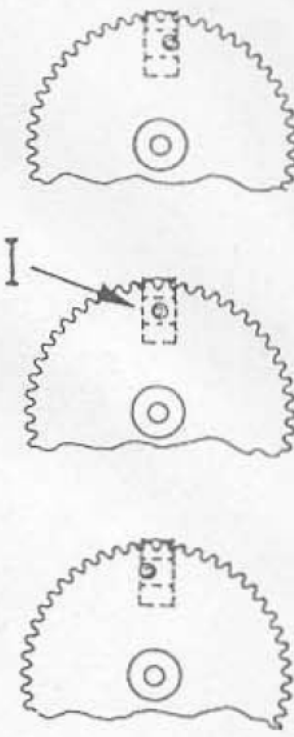

Fig. 1



view from
under neat

Fig. 2

1.5 Insertion of all title holders (Synchronization)

When all title holders are removed and the motor has turned, the synchronization has to be readjusted. During insertion of the title holders it is important, that the pin of the counter wheel is positioned exactly in the center of the opto coupler "sync" (Fig. 2/I, 3/I).

The belt drives for the title holders (Fig. 3/II) have to be in their end position. When this is not the case, one of the pushbuttons ← → or the service button TL/TR has to be used, until position I and the end position are reached.

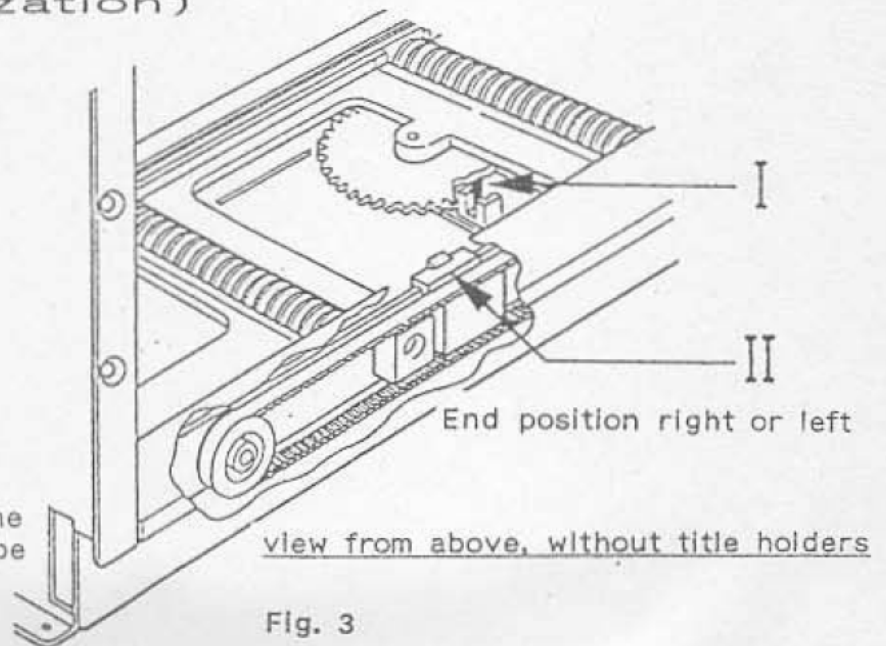

Fig. 3

Now the synchronization has the correct relation to the position of the title holders. The title holders have to be inserted into the worm drives starting from the rear end. In order to do this the title holder has to be bent slightly forward in the center until it fits in the guide. It should be started at the left rear end with "53" (see Fig. 4) then "55", "57" etc until "01"; on the right side it starts with "51", the "49", "47" until "03".

Sequence of title holders (for synchronization)

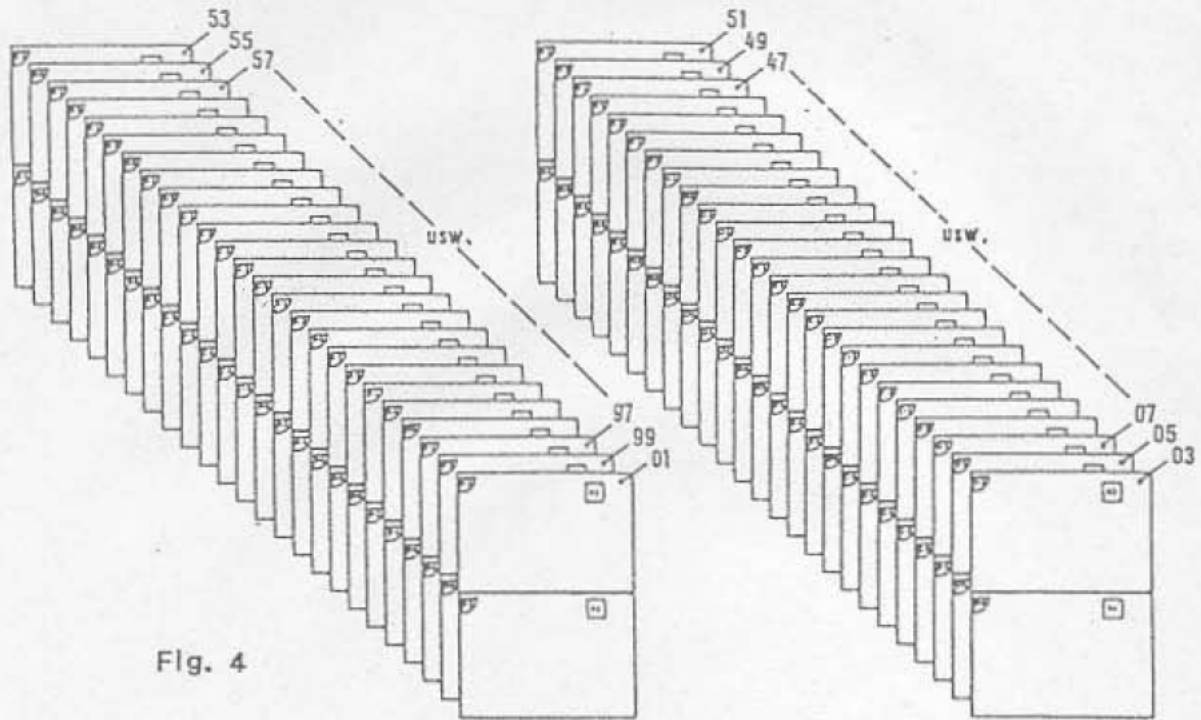

Fig. 4

NOTE! Special care has to be taken during insertion that the first holder has to be inserted into to last slot of the worm drives and the next into the following slot directly in front. If one slot is accidentally skipped, all following title holders have to be removed again.

2 SERVICE

2.1 Operation tests

Service-program-step P60, input test "F2" allows testing of IC1 inputs, port 6. The result is shown on display 3:

The switching position of any give opto couplers is shown on the first digit from the right
"0" = closed, "1" = open

The opto coupler is shown on the second digit from the right

Gripper opto "0" = GRL,
 "1" = GRR.

Switching wheel opto "2" = MOV1,
 "3" = MOV2,
 "4" = MOV3.

Counting wheel opto "5" = SYNCHRON.

Directional pushbuttons "6" = TL,
 "7" = TR.

The port number is shown on the third digit from the right.
"6" = Port 6 on IC 1

SPARE PARTS LIST

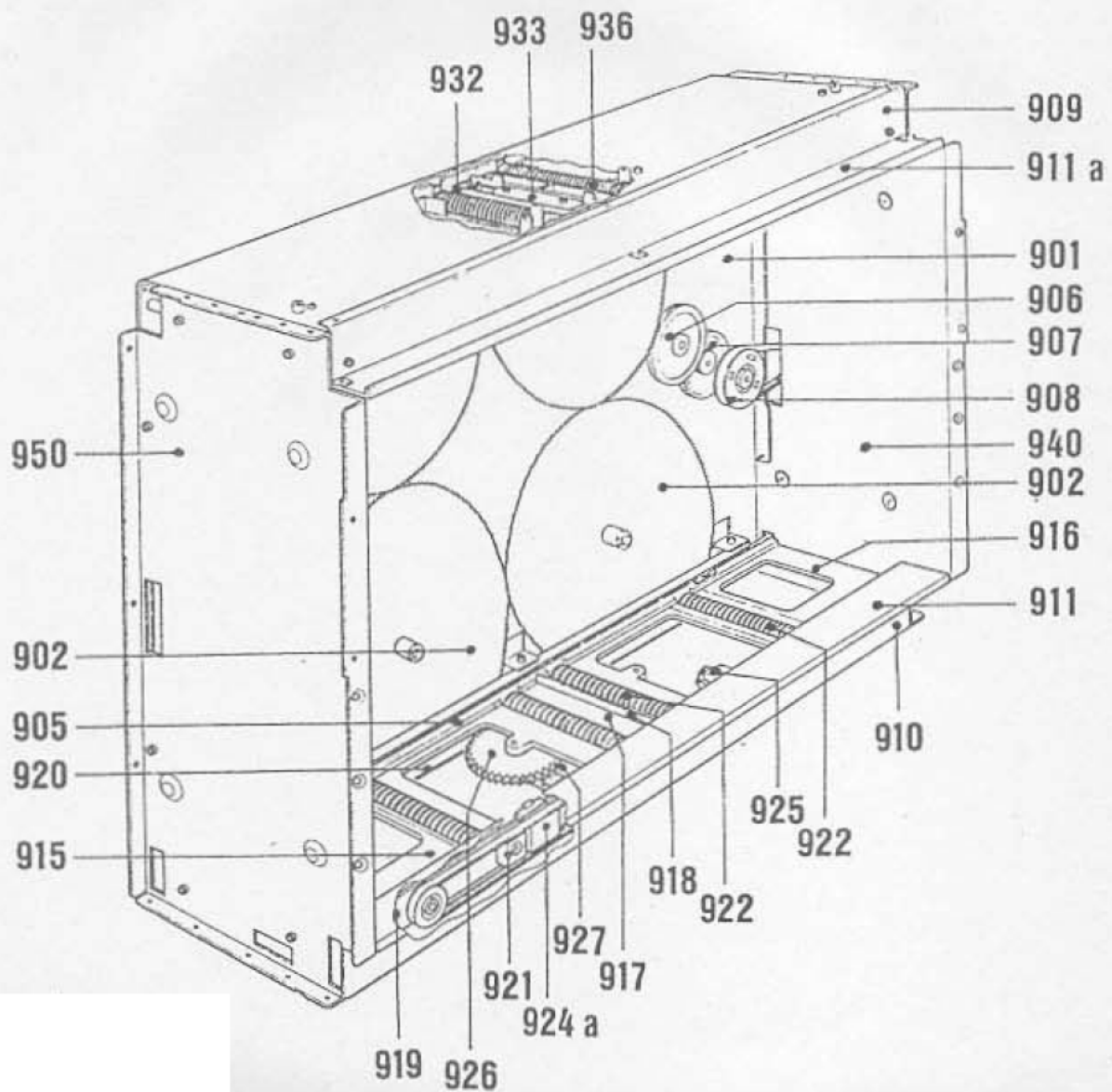

SPARE PARTS LIST

POS.	PART-No.	DESCRIPTION	DATA	QTY
900	174 710	<u>CD-TITLE INDICATION II, ASSY</u>		1
901	174 917	CABINET PLATE, STAMPED		1
	206 100	PLASTIC BEARING	STAR-NYLINER	4
902	174 753	TOOTHED WHEEL	Z = 160	4
903	174 876	SHIFTING WHEEL		1
904	174 929	CB - SHIFTING WHEEL, ASSY		1
905	174 799	GUIDE		1
906	174 886	GEAR WHEEL	Z = 58	1
907	174 875	GEAR WHEEL	Z = 48	1
908	174 878	BELT WHEEL	Z = 52	1
	174 879	WASHER		1
909	174 848	COVER, UPPER		1
910	174 847	COVER, LOWER		1
911	174 900	MASK	LOWER WHITE	1
911a	175 123	MASK	UPPER BLUE	>
	175 124	MASK	UPPER YELLOW	1
912	174 950 to			>
	174 999	TITLE HOLDER II		50
913	206 880	SCOTCH BUMPON		8
	219 185	TITLE STRIP		120
	212 509	TITLE COVER		--
914	175 926	GUIDE PLATE		1
<u>LOWER DECK</u>				
915	175 077	TRAVERSE I, ASSY		1
916	174 881	TRAVERSE II		1
	175 944	TRAVERSE II	from SERIAL-Nr. 9025	1
917	174 797	TRAVERSE, MIDDLE		1
	175 322	TRAVERSE, MIDDLE	from SERIAL-Nr. 9025	1
918	175 321	BRACKET		1
	741 008	BALL \varnothing 6 DIN 5401		2
	205 834	SPRING		2
919	174 906	HOLDING BAR		1
920	174 931	HOLDING BAR, REAR SIDE		1
	175 923	HOLDING BAR, REAR SIDE	from SERIAL-Nr. 9025	1
921	206 794	LOSS		2
922	174 751	WORM, ASSY, LOWER		4
	206 100	PLASTIC BEARING	STAR-NYLINER	4
923	174 898	BELT WHEEL	Z = 28	2
924	206 776	BELT	Typ S2 M800	2
924a	174 846	DRIVE, FRONT SIDE		1
	174 882	DRIVE, REAR SIDE		1
	175 922	DRIVE, REAR SIDE	from SERIAL-Nr. 9025	1

SPARE PARTS LIST

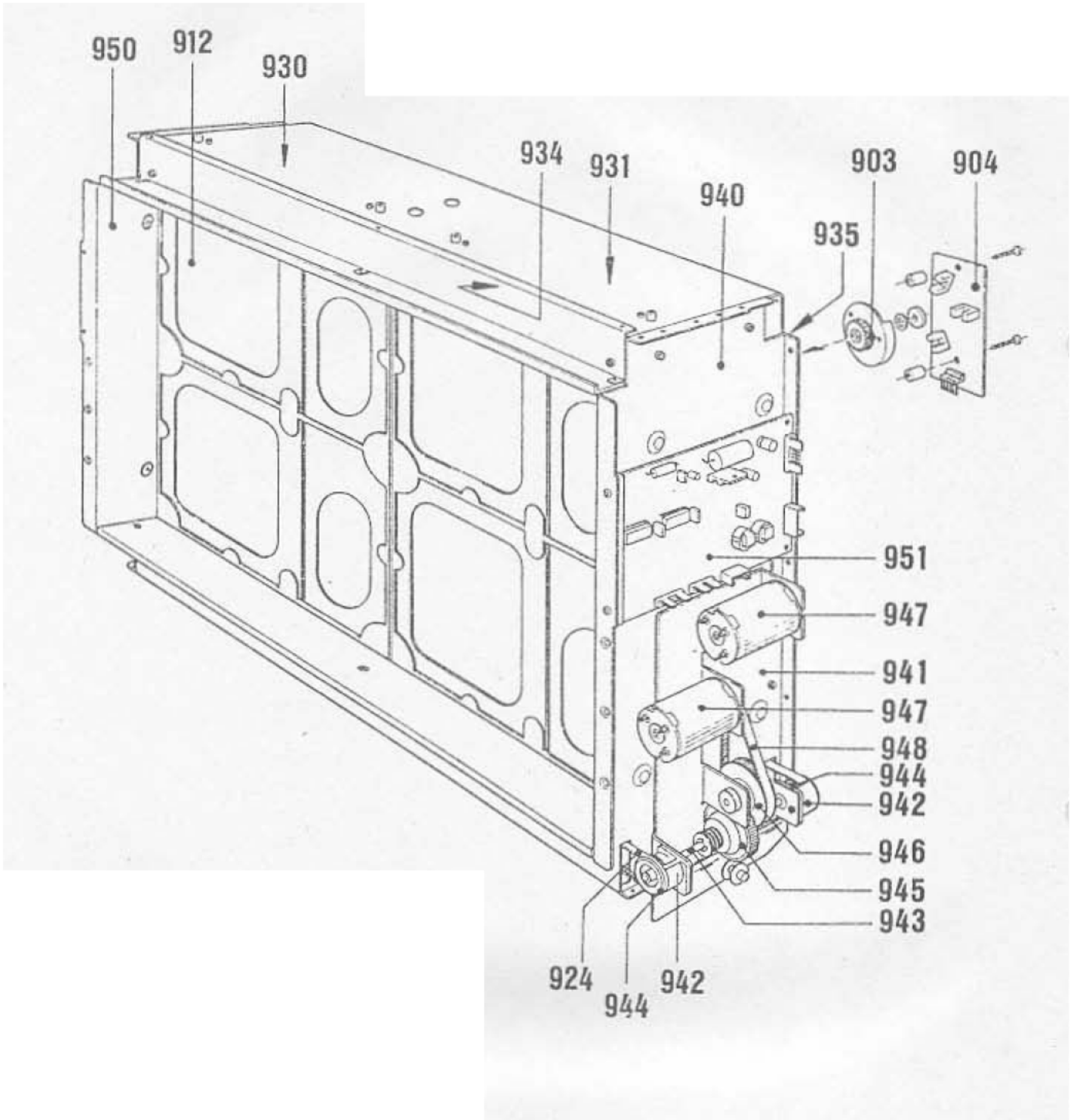

SPARE PARTS LIST

POS.	PART-No.	DESCRIPTION	DATA	QTY
925	174 930	CB - DRIVE, ASSY	to TRAVERSE I/II	2
926	174 885	COUNTER		1
927	175 078	CB - COUNTER, ASSY		1
	225 412	PLUG CONNECTOR	4 prongs 90°	1
	231 322	COPPLER PLATE	LTH-301	1
	175 103	CABLE HARNESS: SHIFTING WHEEL		1
	175 104	CABLE HARNESS: DRIVE		1
UPPER DECK				
930	174 791	TRAVERSE I		1
	175 943	TRAVERSE I	from SERIAL-Nr. 9025	1
931	174 881	TRAVERSE II		1
	175 944	TRAVERSE II	from SERIAL-Nr. 9025	1
932	174 797	TRAVERSE, MIDDLE		1
	175 322	TRAVERSE, MIDDLE	from SERIAL-Nr. 9025	1
933	175 321	BRACKET		1
	741 008	BALL \varnothing 6	DIN 5401	2
	205 834	SPRING		2
934	174 798	HOLDING BAR I		1
935	174 931	HOLDING BAR, REAR SIDE		1
	175 923	HOLDING BAR, REAR SIDE	from SERIAL-Nr. 9025	1
936	174 764	WORM, ASSY, UPPER		4
SIDE PART				
940	174 932	SIDE PLATE, RIGHT, STAMPED		1
941	174 925	MOTOR- and GEAR PLATE, STAMPED		1
942	174 926	BELT PROTECTION, ASSY		2
943	174 924	DRIVE AXLE		1
	175 270	COUPLING (PART 1)		1
	211 271	COUPLING (PART 2)		1
	205 807	SPRING		1
944	174 898	BELT WHEEL	Z = 28	2
945	174 875	GEAR WHEEL	Z = 48	1
946	174 878	BELT, WHEEL	Z = 52	1
	174 879	WASHER		1
947	174 889	MOTOR, ASSY		2
948	206 789	BELT WHEEL	40 S2 M180	2
950	174 912	SIDE PLATE		1
	175 946	SIDE PLATE	from SERIAL-Nr. 9025	1
951	174 928	CB - TITLE INDICATION, ASSY	see Page 907	1

SPARE PARTS LIST

POS.	PART-No.	DESCRIPTION	DATA	QTY
	174 928	<u>CB - TITLE INDICATION II</u>		1
ST 4	225 443	PIN PLUG	6 prongs red	1
ST 3	225 444	PIN PLUG	8 prongs red	1
ST 1	225 440	PIN PLUG	10 prongs red	1
ST 2	225 710	PIN PANEL	4 prongs	1
ST 6	225 711	PIN PANEL	6 prongs	1
TL, TR	222 404	CONTACT BUTTON	D 6 red	2
IC 1	221 763	IC-CMOS	HEF 4021 B	1
IC 2	221 771	IC-CMOS	HEF 4094 B	1
IC 3	231 303	IC-LINEAR	L 298	1
D 1-8	221 822	SI-DIODE	BA - 157	8
D 9	221 114	SI-DIODE	1 N 4148	1
T 1	221 283	SI-TRANSISTOR	BC 212 B	1
C 1-3, 9	220 334	MKT-CAPACITOR	0,1 µF 63 V	4
C 6	220 332	MKT-CAPACITOR	0,33 µF 63 V	1
C 7	220 162	LYTIC	10 µF 63 V	1
C 4, 8	220 250	LYTIC	100 µF 25 V	2
C 5	220 253	LYTIC	1000 µF 25 V	1
R 33	221 620	RESISTOR	22 Ω ½ W	1
R 31	221 600	RESISTOR	100 Ω ½ W	1
R 25-27	221 033	RESISTOR	3,3 KΩ ½ W	3
R 19, 26-30	221 035	RESISTOR	10 KΩ ½ W	4
R 11-18	221 603	RESISTOR	12 KΩ ½ W	8
R 2-9	221 036	RESISTOR	15 KΩ ½ W	8
R 32	221 604	RESISTOR	22 KΩ ½ W	1
R 20	221 049	RESISTOR	470 KΩ ½ W	1
R 23, 35	221 273	RESISTOR	10 Ω ½ W	2
R 21, 22	221 392	RESISTOR	390 Ω ½ W	2
R 24	221 692	WIRE WOUND RESISTOR	1 Ω	1
R 36	221 169	WIRE WOUND RESISTOR	10 Ω	1

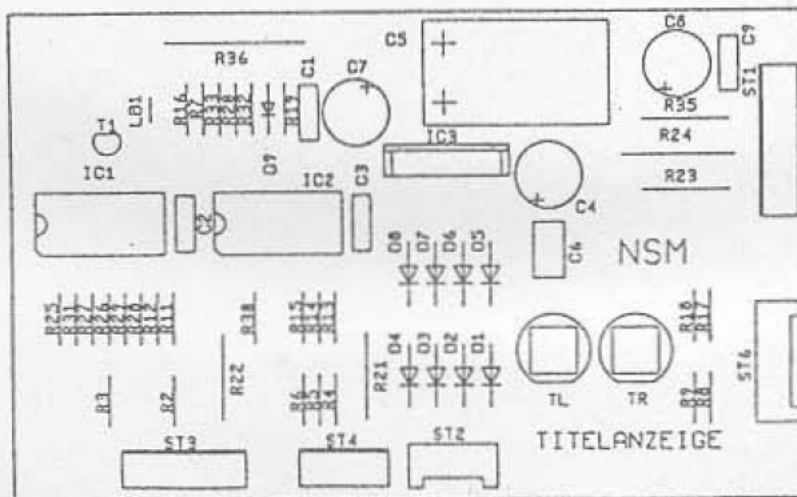

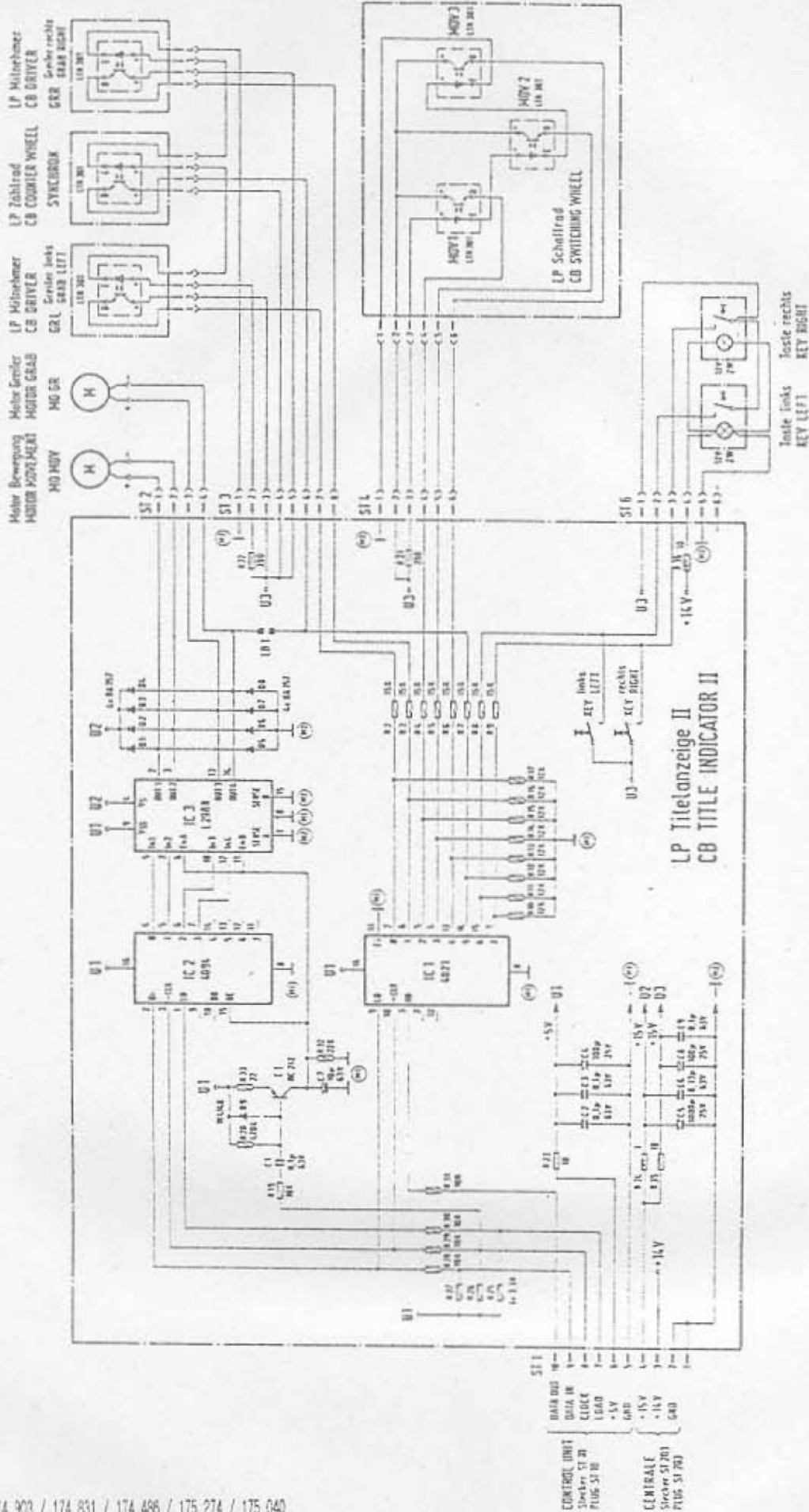

ANWENDER IM SINNE DES HEINER FÜRORDNUNGS VERBÄHRLICH
 JEDER VON BEIHER ANWENDUNG
 SUBJEKT ZU TECHNISCHE MODIFICATION WITHOUS OBLIGATION
 IS HOBBY EQUIPMENT ALREADY BELONGS!

MUSIKAUTOMATEN
 PHOTOGRAPHS
 ES IV - CD TECHNOLOGY
 Titelanzeiger II
 WIRING DIAGRAM
 TITLE INDICATOR II



TROUBLE SHOOTING FOR NSM-PHONOGRAPHS

ES IV-CD TECHNOLOGY

to
Technical Information, Assy

174 903	SILVER CITY
174 831	SILVER SKY
174 486	FASCINATION
175 274	SOUNDMASTER
175 040	FIRE BIRD/COUNTRY

NSM
Aktiengesellschaft
Saarlandstraße 240
6530 Bingen am Rhein

14

Page 1401-1406

INDEX

- 1 TROUBLE SHOOTING
 - 1.1 Description of malfunction/cause
 - 1.2 Error displays
 - 1.3 Trouble shooting for NSM phonographs ES-IV/CD technology

1 TROUBLE SHOOTING

1.1 Description of malfunction/cause

DESCRIPTION	CAUSE
Phonograph illumination and LED's in central unit/CD supply do not light up.	<ol style="list-style-type: none">1. Power cord2. Main switch3. Power fuse (switch plate/fuse box)
Phonograph illumination okay, LED's in central unit do no light up.	<ol style="list-style-type: none">1. Plug connection ST 200 of central unit2. Fuses Si 201-205 of central unit3. Power transformer connection
Luminous effect lights do not light phonographs with light generator).	<ol style="list-style-type: none">1. Fuse T 8 A on switch plate2. Fuses Si 701-703 as well as3. Plug connection of luminous effects PCB
Fan for output stage does not run while disc is playing.	<ol style="list-style-type: none">1. Plug connection ST 2092. Triac TIC 200.3. Transistor T 204/205.
+5 V; 15 V-LED's in central unit do not light up or are darker Fuses are okay.	<ol style="list-style-type: none">1. Voltage regulators VR 201-203 in central unit defective2. Short circuit in connected units. (Pull plugs one after another and observe LED's).
No tone signal at loudspeaker even though a CD is playing and the volume is switched on.	<ol style="list-style-type: none">1. loudspeaker connection2. Plug connection of frequency network and output transformer3. Interruption on signal wire (plug connection "ST" 4-pol. of central unit to "ST 2" on changer adapter, from "ST 3" on changer adapter to decoder board).
Volume reduced by electronic protection device.	<ol style="list-style-type: none">1. loudspeaker mismatch (less than 2 ohms impedance) due to remote speakers.2. Transistor T 252 defective.3. Output transistor defective.4. Control unit defective.
Poor bass reproduction.	Loudspeaker connections reversed.
Er xx-display.	See "Error Displays".

1.2 Error Displays

Displays	Possible Causes	Corrections
1 2 3		
Er 01	EPROM contents (CONTROL UNIT) interrupted.	Change EPROM (IC 2).
Er 10	RAM (CONTROL UNIT) defective.	Change RAM (IC 3). After that reprogram all program steps (P20-P56).
Er 11	RAM contents (CONTROL UNIT) short-term disturbance.	No correction necessary; program is reinitialized. Change RAM IC 3 if frequently occurring.
Er 20	Verification errors in program (CONTROL UNIT).	No correction necessary; program is reinitialized. Change CPU IC 1 if frequently occurring.
Pxx Er 30	Memory contents (CONTROL UNIT) invalid.	No correction necessary; program step Pxx (in Display 1) is automatically reprogrammed.
Pxx Er 31	Memory contents (CONTROL UNIT) invalid or not programmed.	Service step Pxx shown in Display 1 must be reprogrammed.
Pxx Er 40	Wrong price setting.	Check price setting and, if necessary, reprogram (P41-P45, check sequence).
Er 50	Coin mechanism defective. Too much credit.	Check coin mechanism.
Er 6x	Error at CD player.	See Er 60 - Er 62. Play interrupted after error.
Er 60	Error before playing CD (track selection). No supply voltage present for decoder or player.	Exchange decoder board, microcomputer T018 on pickup driver (IC 8). Check primary fuse in CD transformer.
Er 61	No CD recognized by player. No CD in CD tray, CD defective. Player defective. Decoder board defective. No supply voltage present for decoder or player.	Check CD and exchange if needed. Laser player (CDM-3). Exchange decoder board. Check primary fuse in CD transformer.
Er 62	Error after playing CD (stop).	As in Er 60.
Er 63	Track cannot be played (CD defective) or choosing a track number which is too high (error display appears only during continuous test P60/3 or P60/4; during regular operation track No. 1 is played when choosing a track number which is too high).	Exchange CD, check track selection.
Er 7x	Malfunction on CD changer.	See Er 70 - Er 76. If error display does not disappear after 2 sec., error cannot be automatically corrected. No CD will be played until cabinet switch or "power on" is activated.
Er 70	CD tray after playing CD incorrect in pickup.	Check function of light barriers OPPUM, OPGRL, OPGRR.
Er 71	Error during grip from left-side magazine.	Check alignment from magazine to pickup assy and adjust if necessary. Check function of light barrier OPPUM.
Er 72	Error during grip from right-side magazine.	As in Er 71.
Er 73	Error during replacing in left-side magazine. Malfunction of left grip lever.	Check alignment of magazine to pickup assy and adjust if needed. Check function of grip. Check function of light barrier OPGRL.
Er 74	Error during replacing of right-side magazine. Malfunction grip lever.	As in ER 73. Check function of light barrier OPGRR.
Er 75	Malfunction during lift drive.	Check lift for jamming. Check function and correct adjustment of light barrier OPSTP (drive wheel).
Er 76	End position of lift not o.k.	Check function and adjustment of light barrier OPEND.

plays		Possible Causes	Corrections
2	3		
Er	80	Short circuit on wallbox signal wire.	Check wallbox connection.
Er	90	Title display, three blocking in sequence, not functional anymore.	} Blocking remedy.
Er	91	Blocking title display, gripper left.	
Er	92	Blocking title display, gripper right.	
Er	93	Blocking title display, stack left.	
Er	94	Blocking title display, stack right.	

the memorized values of program steps P20 to P56 are checked after each "power on" and by activating the cabinet latch.

In case of an error on the programmable memory area the corresponding program steps is shown on Display 1; Pxx Er 31; the "error" lamp flashes.

After the phonograph is turned on, the malfunction display in Display 3 and the flashing of "error" remains visible for 2 sec. After that the phonograph is operational; without regarding the malfunctioning program step, though. Using serv.-progr.-step P62, the last 10 error codes can be called; see "service programs" pt. 1.5.7.

1.3 Trouble-Shooting Chart for NSM Phonographs ES-IV/CD Technology

Conditions: Line voltage present, line connection and power supply in order.

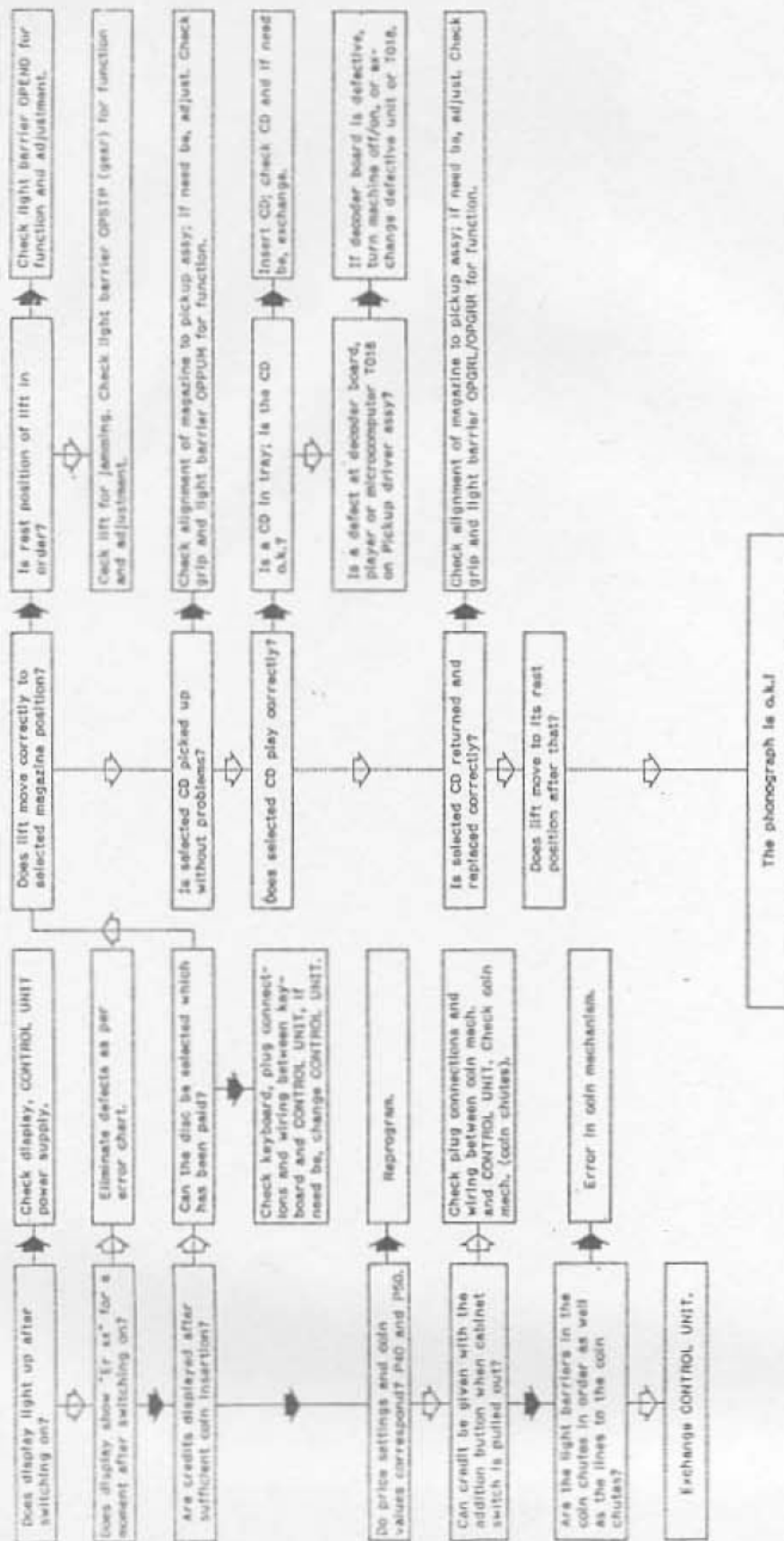

◇ : 14
 ◆ : 15

Compare also 1.2 "Error Displays".