

UNIT DESCRIPTION

TITLE INDICATION II FOR NSM-PHONOGRAPH

ES IV-CD TECHNOLOGY

to
Technical Information, Assy

174 903	SILVER CITY
174 831	SILVER SKY
174 486	FASCINATION
175 274	SOUNDMASTER
175 040	FIRE BIRD/COUNTRY

NSM
Aktiengesellschaft
Saarlandstraße 240
6530 Bingen am Rhein

9

Page 901-911

1 FUNCTION

1.1 PCB Title display

The PCB is connected to the serial interface and +5 V of the control unit via ST 1. +15 V and +14 V are also conducted via ST 1. The constant voltage of +15 V supplies motors and opto couplers.

Shiftregister IC 2 is the output port for motor driver IC 3, which controls the motor for stacker movement (MO MOV) and the gripper motor (MO GR).

Shiftregister IC 1 is the input port for opto couplers and push buttons. Light barriers GRL and GRR control the endposition of the gripper (carrier). MOV1, MOV2 and MOV3 supervise various positions during the stacker movement. Any blocking will be recognized and displayed by error code Er 9x.

Pushbuttons TL and TR in the PCB are service keys for moving title holders.

They are identical with pushbuttons (←) and (→) on the front of the phonograph.

1.2 Movement of title holders

By pushing the keys "left" respectively "right" two title holder will be moved into the corresponding direction (from program index 08).

A complete movement consists out of following phases: If i.e. the key "left" is pushed, at first the position of the gripper will be checked and -if required- the front gripper positioned in front of the right hand stack. Both stacks are level. Now the right stack moves to the front while the left one moves back simultaneously until the grippers enter the carrier slots of the corresponding title holders. Then the grippers move the title holder to the other side. In the final position the right hand stack will be moved forward while the left hand stack will be moved backward until they are level. The grippers will be brought back to their starting position. In case of a limitation of selectable CD's via service step P22 only the corresponding title holders will be shown. A movement to the right beyond the highest covernumber as well as to the left below covernumber 1 is not possible.

1.3 Exchange of defective title holders

When defective title holders can still be driven to the front by the motor, the exchange of the holder should be performed there.

For removal, the center of the title holder has to be bent slightly forward until it jumps out of the top guide. The insertion of the new title holder works accordingly.

1.4 Jammed or dislocated title holders

When the transportation by motor is impossible due to jamming, all title holders in front of the jamming location have to be removed. After correcting the problem the title holders have to be inserted in the same sequence (Fig. 1).

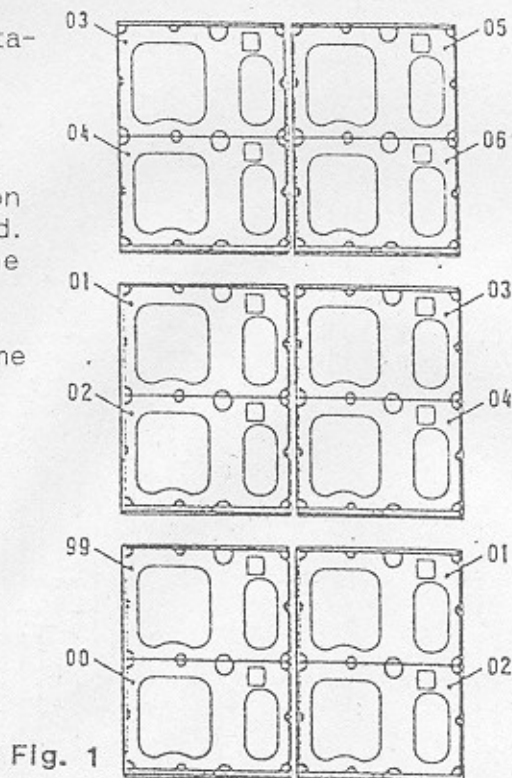

Fig. 1

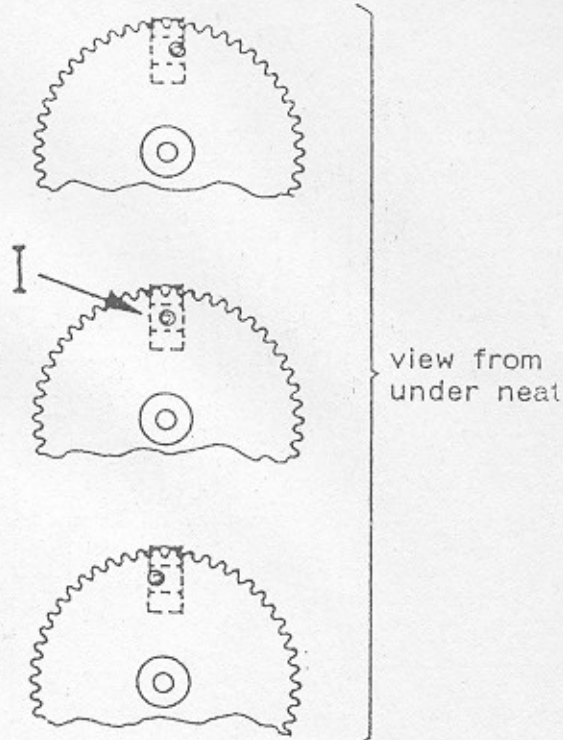

Fig. 2

1.5 Insertion of all title holders (Synchronization)

When all title holders are removed and the motor has turned, the synchronization has to be readjusted. During insertion of the title holders it is important, that the pin of the counter wheel is positioned exactly in the center of the opto coupler "sync" (Fig. 2/I, 3/I). The belt drives for the title holders (Fig. 3/II) have to be in their end position. When this is not the case, one of the pushbuttons ← → or the service button TL/TR has to be used, until position I and the end position are reached.

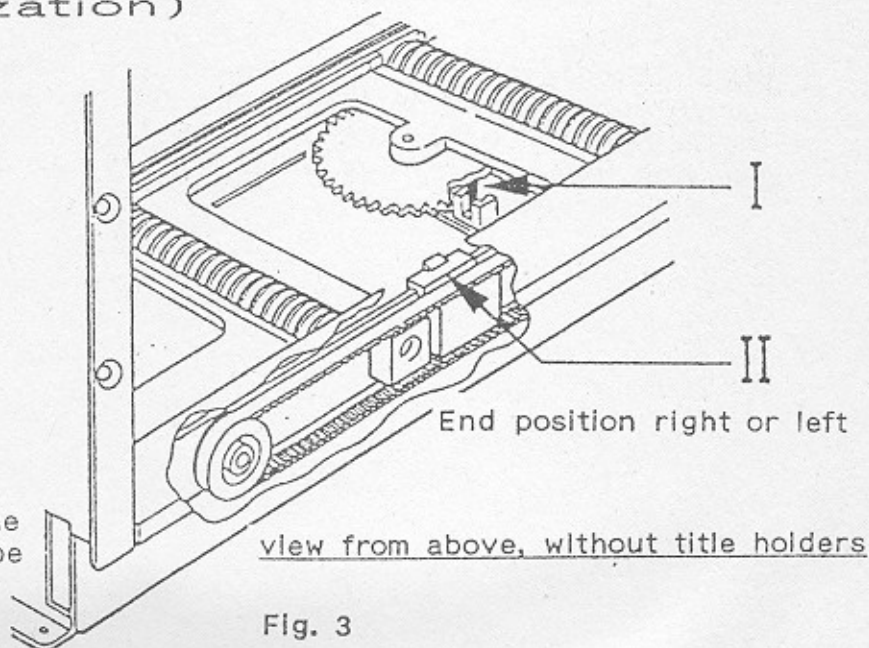

Fig. 3

Now the synchronization has the correct relation to the position of the title holders. The title holders have to be inserted into the worm drives starting from the rear end. In order to do this the title holder has to be bent slightly forward in the center until it fits in the guide. It should be started at the left rear end with "53" (see Fig. 4) then "55", "57" etc until "01"; on the right side it starts with "51", the "49", "47" until "03".

Sequence of title holders (for synchronization)

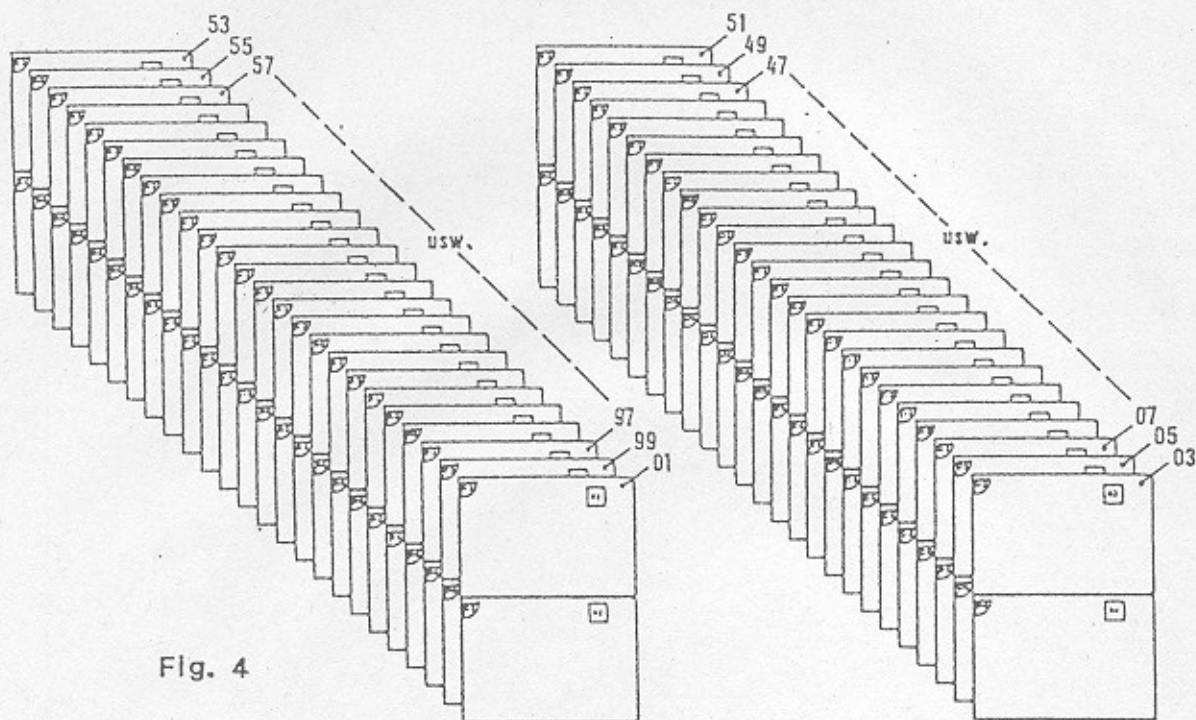

Fig. 4

NOTE! Special care has to be taken during insertion that the first holder has to be inserted into to last slot of the worm drives and the next into the following slot directly in front. If one slot is accidentally skipped, all following title holders have to be removed again.

2 SERVICE

2.1 Operation tests

Service-program-step P60, input test "F2" allows testing of IC1 inputs, port 6. The result is shown on display 3:

The switching position of any give opto couplers is shown on the first digit from the right
"0" = closed, "1" = open

The opto coupler is shown on the second digit from the right

Gripper opto
"0" = GRL,
"1" = GRR.

Switching wheel opto
"2" = MOV1,
"3" = MOV2,
"4" = MOV3.

Counting wheel opto
"5" = SYNCHRON.

Directional pushbuttons
"6" = TL,
"7" = TR.

The port number is shown on the third digit from the right.
"6" = Port 6 on IC 1

SPARE PARTS LIST

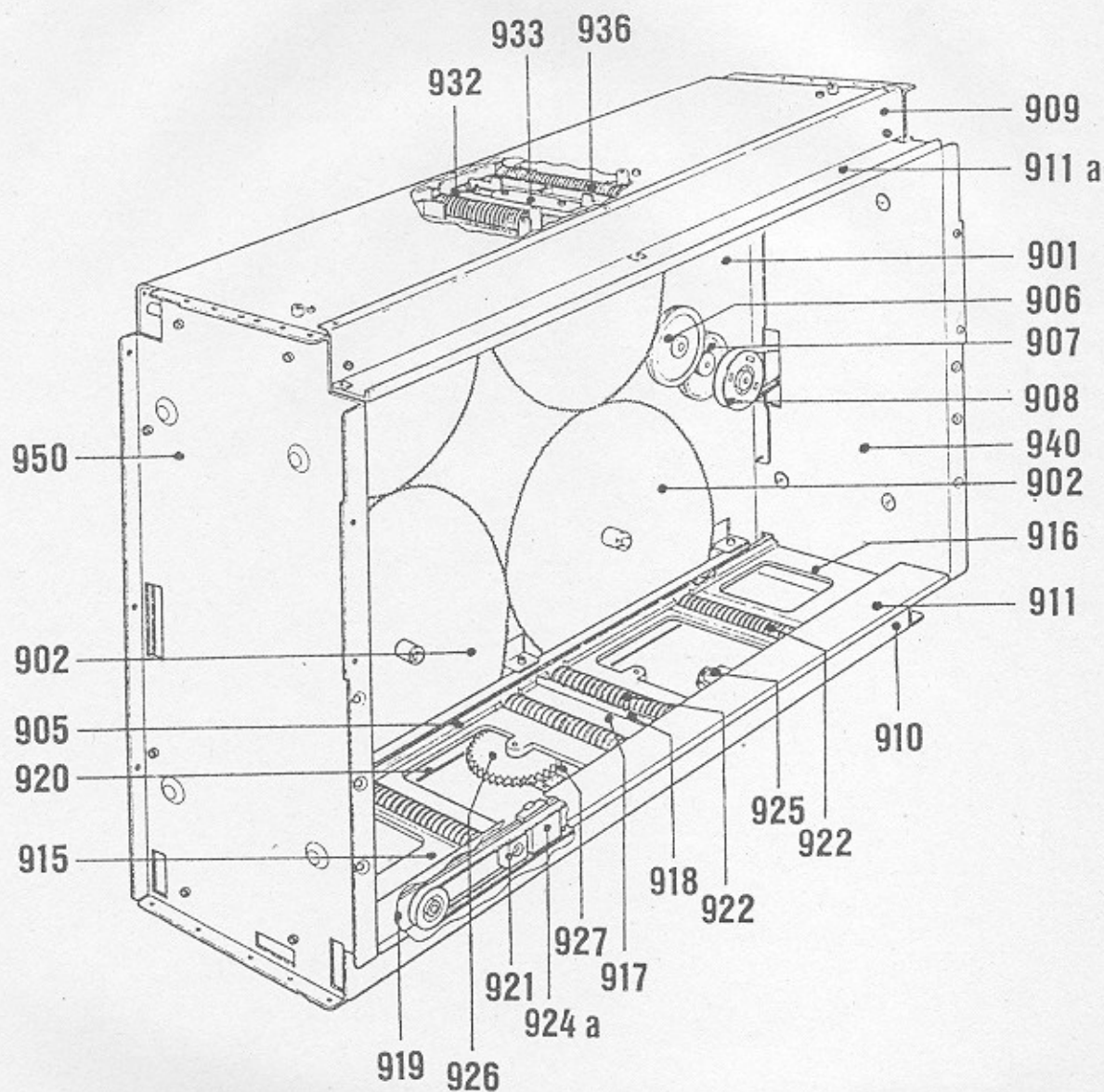

SPARE PARTS LIST

POS.	PART-No.	DESCRIPTION	DATA	QTY
900	174 710	<u>CD-TITLE INDICATION II, ASSY</u>		1
901	174 917	CABINET PLATE, STAMPED		1
	206 100	PLASTIC BEARING	STAR-NYLINER	4
902	174 753	TOOTHED WHEEL	Z = 160	4
903	174 876	SHIFTING WHEEL		1
904	174 929	CB - SHIFTING WHEEL, ASSY		1
905	174 799	GUIDE		1
906	174 886	GEAR WHEEL	Z = 58	1
907	174 875	GEAR WHEEL	Z = 48	1
908	174 878	BELT WHEEL	Z = 52	1
	174 879	WASHER		1
909	174 848	COVER, UPPER		1
910	174 847	COVER, LOWER		1
911	174 900	MASK	LOWER WHITE	1
911a	175 123	MASK	UPPER BLUE	>
	175 124	MASK	UPPER YELLOW	1
912	174 950 ^{to}			>
	174 999	TITLE HOLDER II		50
913	206 880	SCOTCH BUMPON		8
	219 185	TITLE STRIP		120
	212 509	TITLE COVER		--
914	175 926	GUIDE PLATE		1
<u>LOWER DECK</u>				
915	175 077	TRAVERSE I, ASSY		1
916	174 881	TRAVERSE II		1
	175 944	TRAVERSE II	from SERIAL-Nr. 9025	1
917	174 797	TRAVERSE, MIDDLE		1
	175 322	TRAVERSE, MIDDLE	from SERIAL-Nr. 9025	1
918	175 321	BRACKET		1
	741 008	BALL \varnothing 6 DIN 5401		2
	205 834	SPRING		2
919	174 906	HOLDING BAR		1
920	174 931	HOLDING BAR, REAR SIDE		1
	175 923	HOLDING BAR, REAR SIDE	from SERIAL-Nr. 9025	1
921	206 794	LOSS		2
922	174 751	WORM, ASSY, LOWER		4
	206 100	PLASTIC BEARING	STAR-NYLINER	4
923	174 898	BELT WHEEL	Z = 28	2
924	206 776	BELT	Typ S2 M800	2
924a	174 846	DRIVE, FRONT SIDE		1
	174 882	DRIVE, REAR SIDE		1
	175 922	DRIVE, REAR SIDE	from SERIAL-Nr. 9025	1

SPARE PARTS LIST

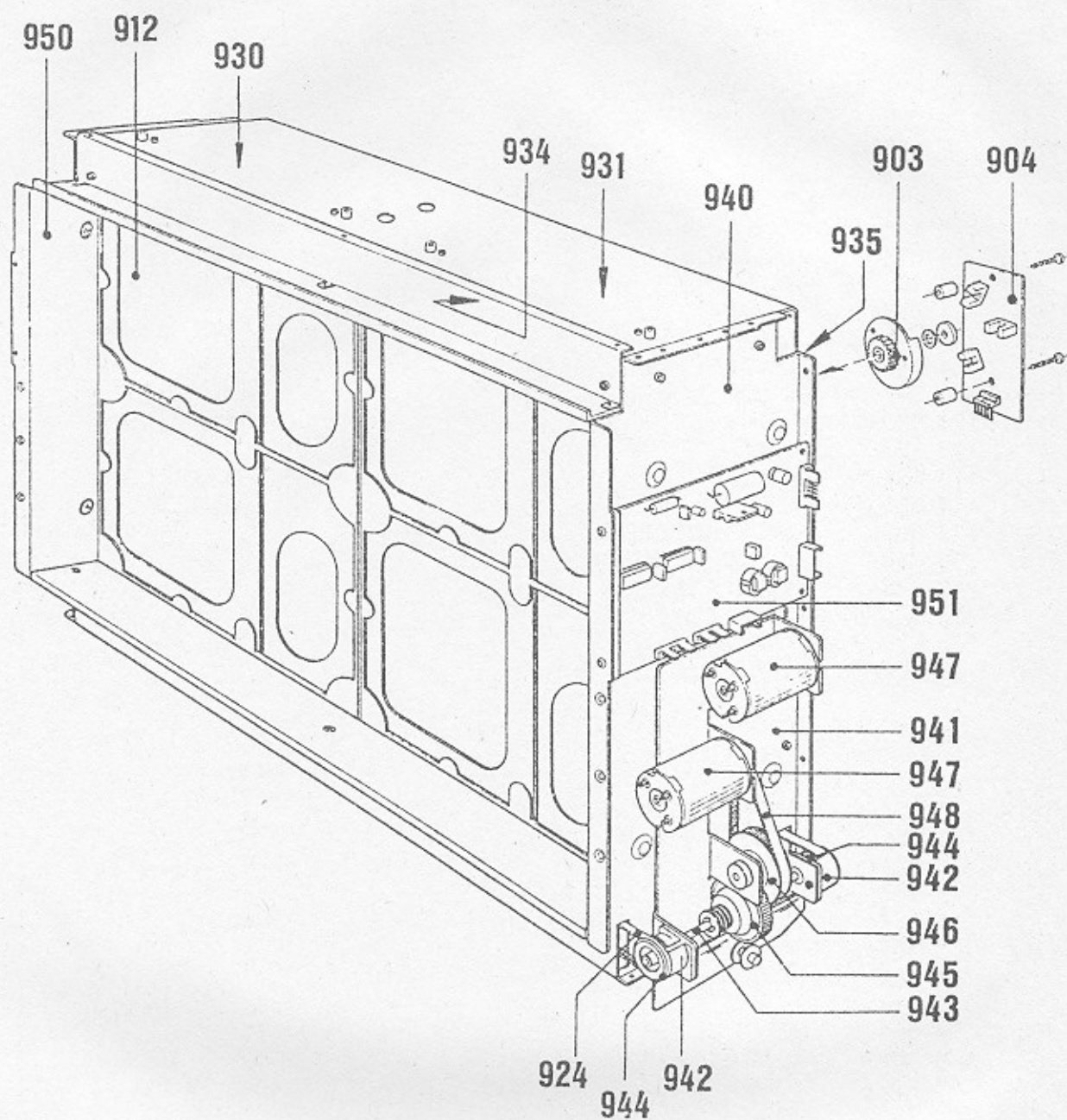

SPARE PARTS LIST

POS.	PART-No.	DESCRIPTION	DATA	QTY
925	174 930	CB - DRIVE, ASSY	to TRAVERSE I/II	2
926	174 885	COUNTER		1
927	175 078	CB - COUNTER, ASSY		1
	225 412	PLUG CONNECTOR	4 prongs 90°	1
	231 322	COPPLER PLATE	LTH-301	1
	175 103	CABLE HARNESS: SHIFTING WHEEL		1
	175 104	CABLE HARNESS: DRIVE		1
<u>UPPER DECK</u>				
930	174 791	TRAVERSE I		1
	175 943	TRAVERSE I	from SERIAL-Nr. 9025	1
931	174 881	TRAVERSE II		1
	175 944	TRAVERSE II	from SERIAL-Nr. 9025	1
932	174 797	TRAVERSE, MIDDLE		1
	175 322	TRAVERSE, MIDDLE	from SERIAL-Nr. 9025	1
933	175 321	BRACKET		1
	741 008	BALL \varnothing 6	DIN 5401	2
	205 834	SPRING		2
934	174 798	HOLDING BAR I		1
935	174 931	HOLDING BAR, REAR SIDE		1
	175 923	HOLDING BAR, REAR SIDE	from SERIAL-Nr. 9025	1
936	174 764	WORM, ASSY, UPPER		4
<u>SIDE PART</u>				
940	174 932	SIDE PLATE, RIGHT, STAMPED		1
941	174 925	MOTOR- and GEAR PLATE, STAMPED		1
942	174 926	BELT PROTECTION, ASSY		2
943	174 924	DRIVE AXLE		1
	175 270	COUPLING (PART 1)		1
	211 271	COUPLING (PART 2)		1
	205 807	SPRING		1
944	174 898	BELT WHEEL	Z = 28	2
945	174 875	GEAR WHEEL	Z = 48	1
946	174 878	BELT, WHEEL	Z = 52	1
	174 879	WASHER		1
947	174 889	MOTOR, ASSY		2
948	206 789	BELT WHEEL	40 S2 M180	2
950	174 912	SIDE PLATE		1
	175 946	SIDE PLATE	from SERIAL-Nr. 9025	1
951	174 928	CB - TITLE INDICATION, ASSY	see Page 907	1

SPARE PARTS LIST

POS.	PART-No.	DESCRIPTION	DATA	QTY
	174 928	<u>CB - TITLE INDICATION II</u>		1
ST 4	225 443	PIN PLUG	6 prongs red	1
ST 3	225 444	PIN PLUG	8 prongs red	1
ST 1	225 440	PIN PLUG	10 prongs red	1
ST 2	225 710	PIN PANEL	4 prongs	1
ST 6	225 711	PIN PANEL	6 prongs	1
TL, TR	222 404	CONTACT BUTTON	D 6 red	2
IC 1	221 763	IC-CMOS	HEF 4021 B	1
IC 2	221 771	IC-CMOS	HEF 4094 B	1
IC 3	231 303	IC-LINEAR	L 298	1
D 1-8	221 822	SI-DIODE	BA - 157	8
D 9	221 114	SI-DIODE	1 N 4148	1
T 1	221 283	SI-TRANSISTOR	BC 212 B	1
C 1-3, 9	220 334	MKT-CAPACITOR	0,1 μ F 63 V	4
C 6	220 332	MKT-CAPACITOR	0,33 μ F 63 V	1
C 7	220 162	LYTIC	10 μ F 63 V	1
C 4, 8	220 250	LYTIC	100 μ F 25 V	2
C 5	220 253	LYTIC	1000 μ F 25 V	1
R 33	221 620	RESISTOR	22 Ω $\frac{1}{2}$ W	1
R 31	221 600	RESISTOR	100 Ω $\frac{1}{2}$ W	1
R 25-27	221 033	RESISTOR	3,3 K Ω $\frac{1}{2}$ W	3
R 19, 26-30	221 035	RESISTOR	10 K Ω $\frac{1}{2}$ W	4
R 11-18	221 603	RESISTOR	12 K Ω $\frac{1}{2}$ W	8
R 2-9	221 036	RESISTOR	15 K Ω $\frac{1}{2}$ W	8
R 32	221 604	RESISTOR	22 K Ω $\frac{1}{2}$ W	1
R 20	221 049	RESISTOR	470 K Ω $\frac{1}{2}$ W	1
R 23, 35	221 273	RESISTOR	10 Ω $\frac{1}{2}$ W	2
R 21, 22	221 392	RÉSISTOR	390 Ω $\frac{1}{2}$ W	2
R 24	221 692	WIRE WOUND RESISTOR	1 Ω	1
R 35	221 169	WIRE WOUND RESISTOR	10 Ω	1

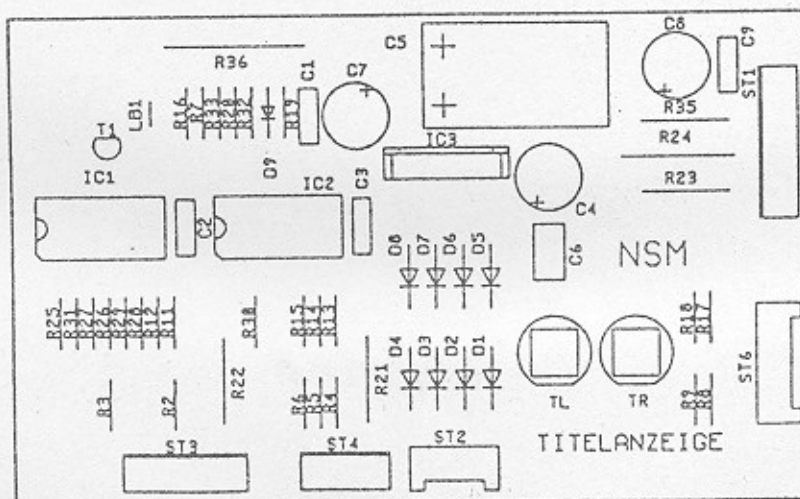

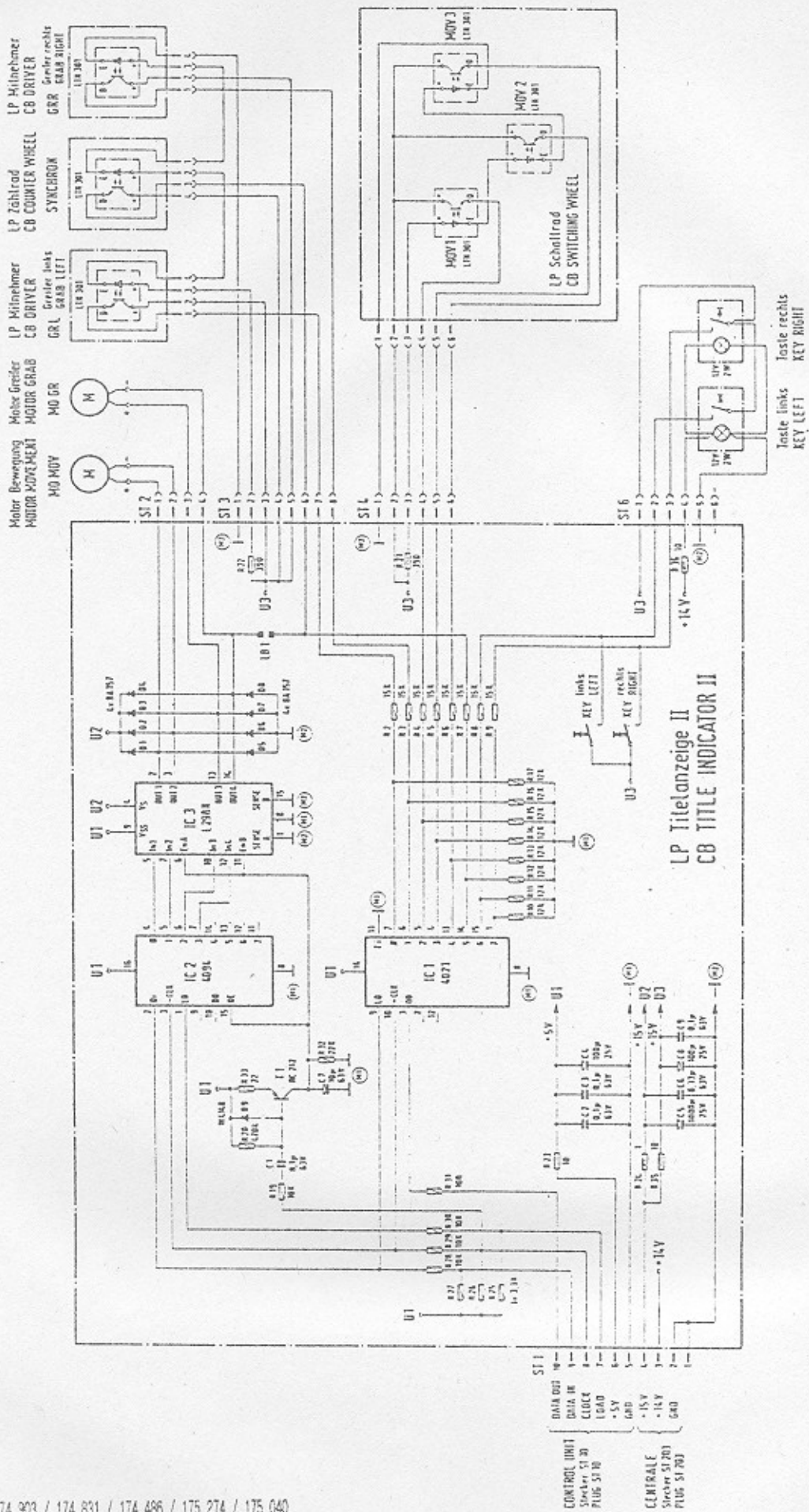

ÄNDERUNGEN IM SINNE DES TECHN. VERGEBENDES VERFAHRENS,
 UNTER BEWÄHRUNG DER VERGEBENDES VERFAHRENS
 SIND FÜR TECHNISCHE MODIFIKATIONEN OHNE VERBODEN
 BEI MODIFIZIERUNG DER AUSRÜSTUNG ALLE RECHT VERBEHALTEN

PHOTODIAGRAMME
ES IV - CD TECHNOLOGY
 Schaltbild
 Titelanzeige II
 WIRING DIAGRAM
 TITLE INDICATOR II

von unten gesehen
 BOTTOM VIEW

BE 212

Druckwerk
 TOP VIEW

(U1, U2, U3)

— A/W
 — B/W
 — C/W