

PART THREE

PARTS CATALOG

INTRODUCTION	3-1
DESCRIPTION	3-1
ORDERING REPLACEMENT PARTS	3-1
PARTS BREAKDOWN	3-2

FIGURE	TITLE	PAGE
1	Phonograph Final Assembly, Model R-81	3-2
2	Selector Assembly	3-10
3	Selector and Speaker Panel Assembly	3-12
4	Top Door Assembly	3-14
5	Front Door Assembly	3-16
6	Side Panel Assembly	3-18
7	Top Access Door Assembly	3-19
8	Mechanism Assembly	3-20
9	Playmeter Assembly	3-27
10	Tone Arm Assembly	3-28
11	Turntable Motor and Plate Assembly	3-29
12	Cam Switch and Motor Assembly	3-30
13	Encoder Assembly	3-32
14	D.C. Converter	3-34
15	Sprag Assembly	3-35
16	Main Power Supply Assembly	3-36
17	Output Transformer Assembly	3-38
18	Shell Assembly	3-39/3-40

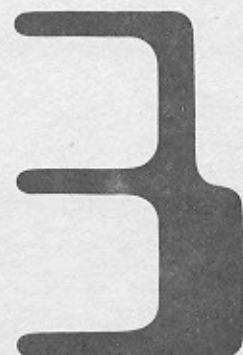

INTRODUCTION

This parts catalog lists procurable replacement parts for the R-81 phonograph.

The purpose of this parts catalog is to locate and identify replaceable components and to supply ordering information.

DESCRIPTION

The parts catalog is divided into 19 major assemblies called "FIGURES" corresponding to the illustrations used. In some instances major assemblies require more than one illustration to identify the procurable parts. In this case sheet numbers are assigned to the figure, i.e. Figure 1, Sheet 1, Figure 1, Sheet 2.

Parts of riveted or welded units are not listed since repair of these parts is normally impractical in the field, however these parts are available as assemblies.

Standard hardware is indicated on each illustration by code letters which are defined in the Standard Hardware List at the rear of the catalog.

To be sure that this parts catalog contained the latest information, last minute revisions were made. In these instances the additions were added in sequence with a letter added to the identification numbers both in the parts list and corresponding illustration i.e., 1A, 1B, 1C.

The Parts List contains four columns:

- Items are listed for reference purposes only.
- The assembly listed has all piece parts indexed below.
- The item listed is an alternate part.
- Two or more assemblies are listed together in one illustration and the same parts are used but in different quantities.

ROWE Part No. - This column lists the part number of the item which should be specified for ordering purposes.

Description - This column contains a brief word description of the assembly or part. Each item is indented to show its proper relationship to the unit of which it is a part or to its next higher assembly.

Qty Per Assy - This column contains the quantity of the part used in the assembly. When a figure covers more than one model of an assembly, the "Qty Per Assy" column is divided to show each model.

ORDERING REPLACEMENT PARTS

All replacement parts must be ordered directly from an authorized ROWE Distributor.

Once the replacement item is determined, complete a standard parts order form available from your ROWE distributor at no charge. Very often parts orders are delayed, because of inadequate or incomplete information. To insure prompt parts delivery always specify the following information:

- Part Number and Description. State color if applicable.
- Quantity required.
- Model and Serial Number of machine for which the repair part is needed.
- Complete shipping address including ZIP code.
- Shipping Instructions must be specified. If the shipping method selected is Parcel Post, Air Parcel Post, United Parcel Service or Air UPS, indicate an alternate shipping method if there is a possibility the packages may exceed the size and weight limits established by these services. If you would like ROWE to select the best way to ship your parts order, specify "BEST WAY". If fastest delivery is the requirement, specify "FASTEST WAY". ROWE will select the carrier for those orders which justify shipment by truck.

Phonograph Final Assembly Sheet 1

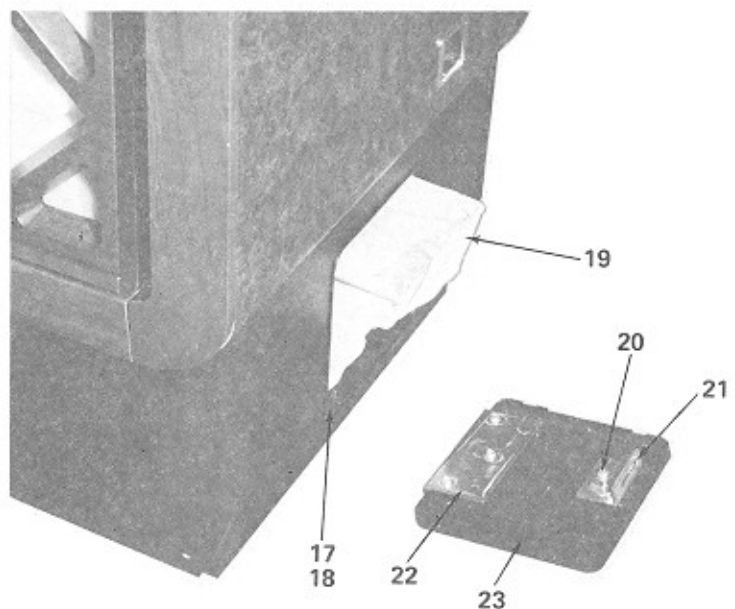
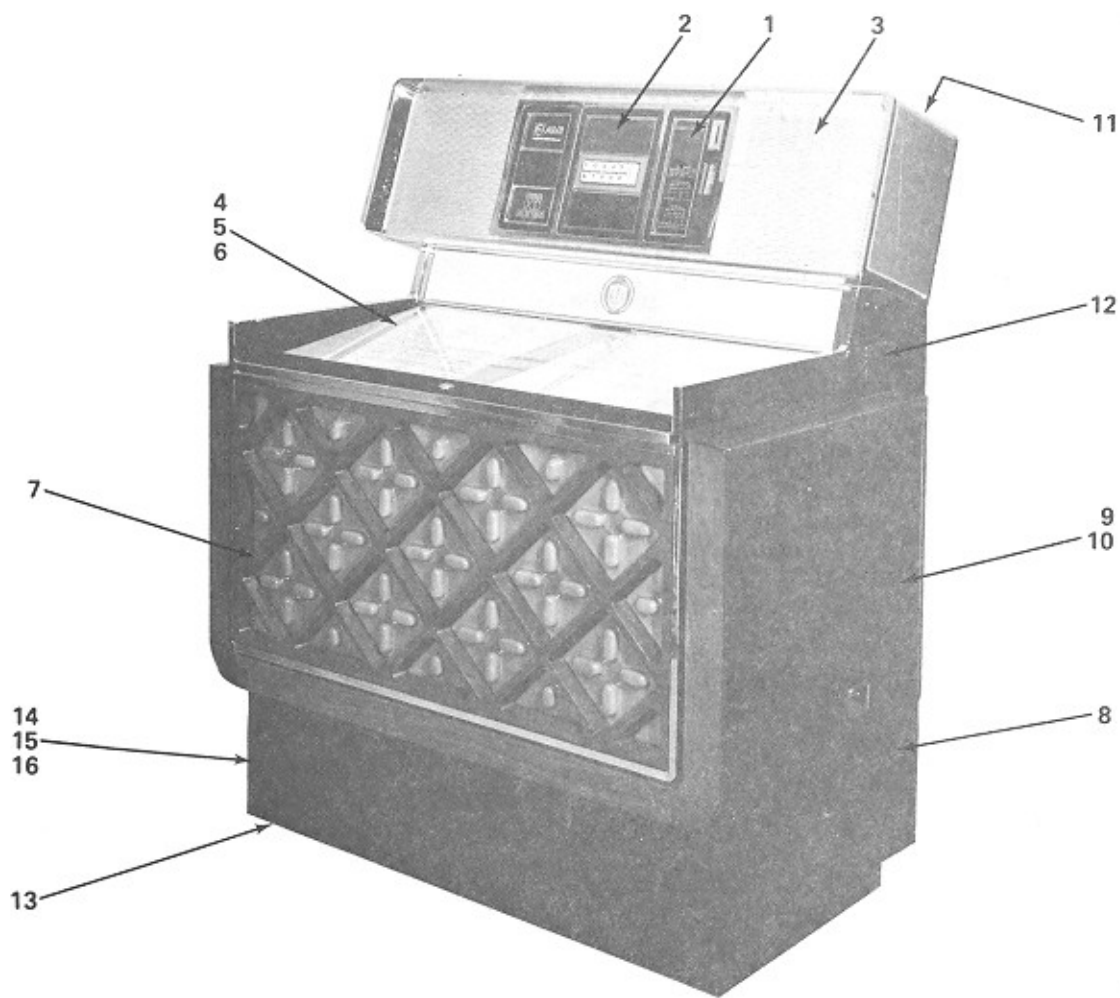

FIG. AND INDEX NO.	ROWE PART NO.	DESCRIPTION	QTY. PER ASSY
1-	601-08200	Phonograph Final Assembly, Model R-81, Wood Style	
1-	602-08200	Phonograph Final Assembly, Model R-81, Scene Style	
	208-17305	. Accessories Bag Assembly	1
	716-00913	. Slip-on Terminal Lug	10
	710-00926	. Pin Contact	3
	711-00926	. Pin Contact	3
	701-00975	. Universal Pin Contact	6
	702-00975	. Universal Socket Contact	6
	701-00756	. Contact, post	6
	708-00720	. 3 Amp Cartridge Fuse (Used on 64W Amplifier)	2
	701-00721	. 0.5 Amp Cartridge Fuse (Used on Main Power Supply)	1
	722-00721	. 3 Amp Cartridge Fuse (Used on Main Power Supply)	1
	725-00721	. 2.5 Amp Cartridge Fuse (Used on Main Power Supply)	1
	301-07442	. Decorative Panel (Covers Bill Acceptor Opening When No B.A. Is Used)	1
	201-17557	. Insert Retainer (Used To Hold Decorative Panel Above)	1
1	301-07710	. Universal Price Card	1
	601-07681	. Universal Price Selection Card	1
2	602-07675	. Selector Assembly (See Figure 2)	1
3	601-08273	. Selector and Speaker Panel Assembly (See Figure 3)	1
4	601-08277	. Top Door Assembly (See Figure 4)	1
5	201-17818	. Hinge Pin	2
6	703-01430	. Retaining Ring	2
7	601-08278	. Front Door Assembly, Wood Style (See Figure 5)	1
7	602-08278	. Front Door Assembly, Scene Style (See Figure 5)	1
8	401-07005	. R.H. Side Panel Overlay	1
	401-07004	. L.H. Side Panel Overlay	1
9	601-08281	. R.H. Side Panel Assembly (See Figure 6)	1
	601-08280	. L.H. Side Panel Assembly (See Figure 6)	1
10	301-07714	. Filler Pad	2
11	601-08272	. Top Access Door Assembly (See Figure 7)	1
12	402-06801	. R.H. Side Trim (Door)	1
	402-06800	. L.H. Side Trim (Door)	1
13	201-17805	. Protective Strap	1
14	401-07006	. Lower Grille	1
15	201-17820	. Bottom Grille Foamed Pad	1
16	201-17806	. Acoustical Pad, 9" x 60"	1
17	405-05276	. Cash Box Door Frame	1
18	200-11449	. Speed Clip, "U" Type	1
19	301-07026	. Cash Bag	1
	205-11866	. Cash Box Door Assembly	1
20	716-01600	. Cylinder Lock	1
21	200-06695	. Lock Support	1
22	200-07703	. Catch Bracket	1
23	605-03267	. Cash Box Door	1

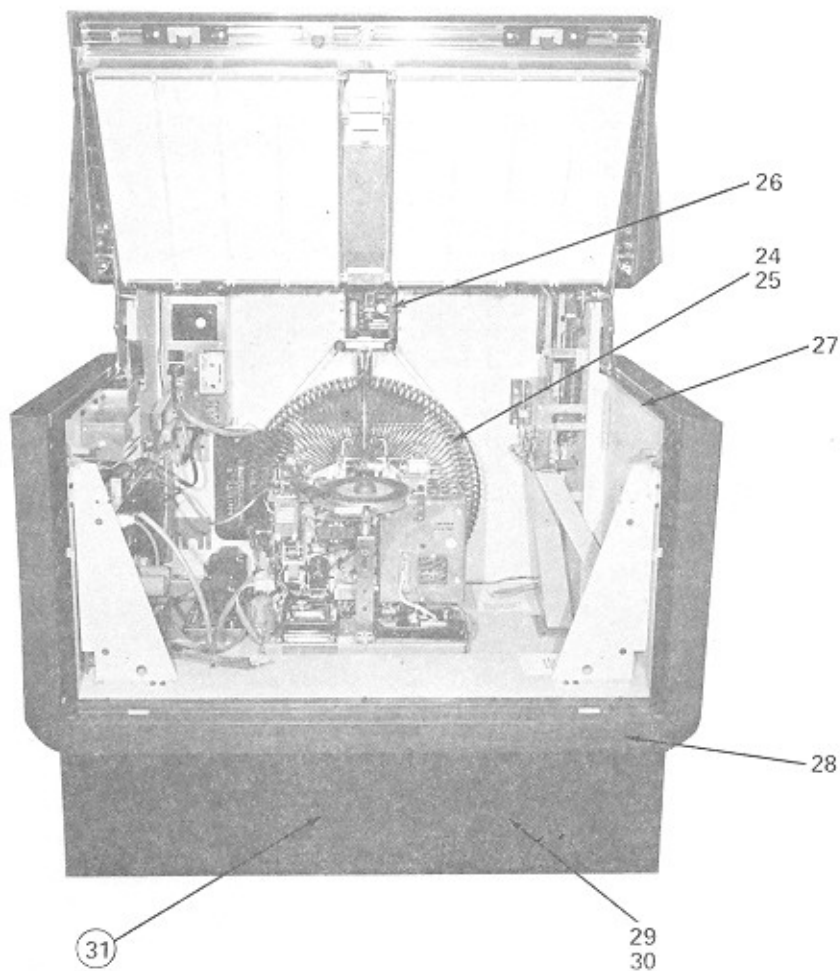
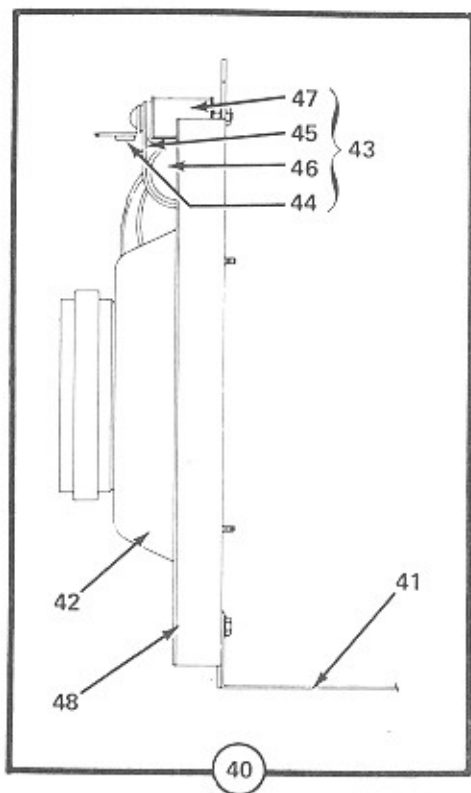
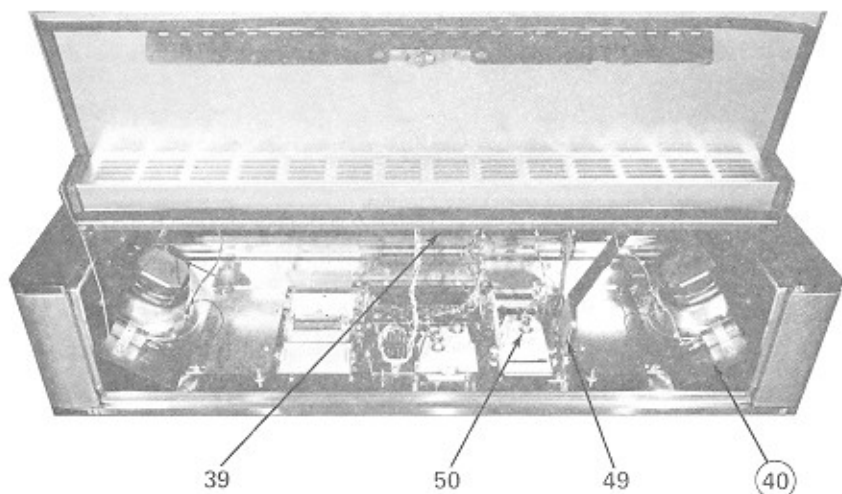
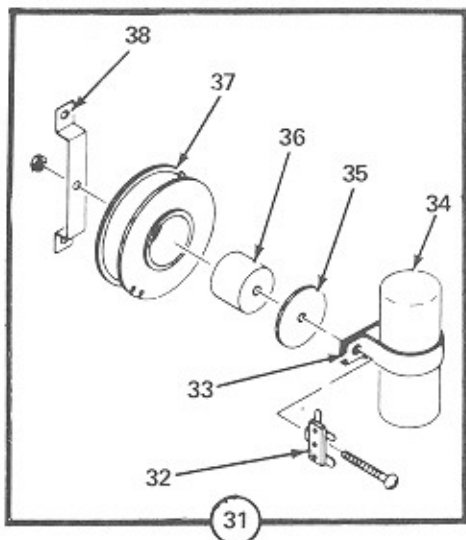

FIG. AND INDEX NO.	ROWE PART NO.	DESCRIPTION	QTY. PER ASSY
1-	601-08200	Phonograph Final Assembly, Model R-81, Wood Style (Continued)	
1-	602-08200	Phonograph Final Assembly, Model R-81, Scene Style (Continued)	
24	601-03065	. Record Changer Mechanism Assembly (See Figure 8)	1
25	200-11537	. Lower Spring Support	4
26	601-07674	. Credit Computer (See Schematic, page 2-36 for Parts List)	1
27	401-07027	. R.H. Support	1
	401-07026	. L.H. Support	1
28	401-07003	. Front Bar	1
29	201-17807	. Retainer Bracket (Used to mount speakers, Item 30)	8
30	401-07039	. Low Frequency Speaker (Mounted behind grille)	2
31	301-06284	. Low Frequency Speaker Network	1
32	314-04225	. . Terminal Strip	1
33	712-00931	. . Cable Clamp	1
34	200-14006	. . 48 MFD Electrolytic Capacitor, 50V	1
35	704-01200	. . Flat Washer	1
36	710-01211	. . Spacer	1
37	201-10641	. . 10 mH Inductor	1
38	200-09297	. . Bracket	1
39	601-08060	. Selector Logic Module (See Schematic, page 2-36 for Parts List)	1
40	401-07036	. R.H. Speaker Assembly	1
	401-07035	. L.H. Speaker Assembly	1
41	301-07721	. . R.H. Light and Sound Block	1
	301-07720	. . L.H. Light and Sound Block	1
42	401-07037	. . Speaker	1
43	301-07717	. . High Frequency Speaker Network	1
44	314-04225	. . . Terminal Strip	1
45	716-00931	. . . Cable Clamp	1
46	202-17612	. . . 12.5 MFD Electrolytic Capacitor	1
47	201-17828	. . . 3 mH Inductor	1
48	401-07030	. . R.H. Speaker Mounting Bracket	1
	401-07029	. . L.H. Speaker Mounting Bracket	1
49	401-06829	. Upper Coin Chute Assembly	1
50	200-50763	. No. 755 Pilot Lamp, 6.3V, Type T-3-1/4	2

Phonograph Final Assembly Sheet 3

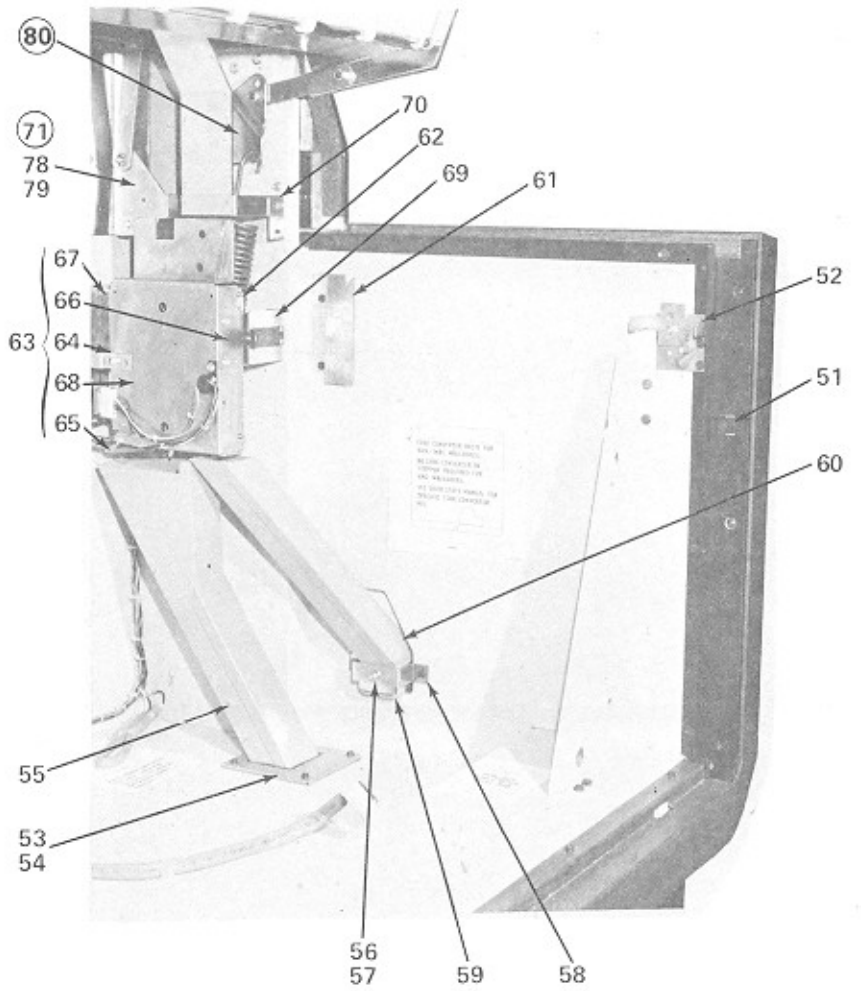
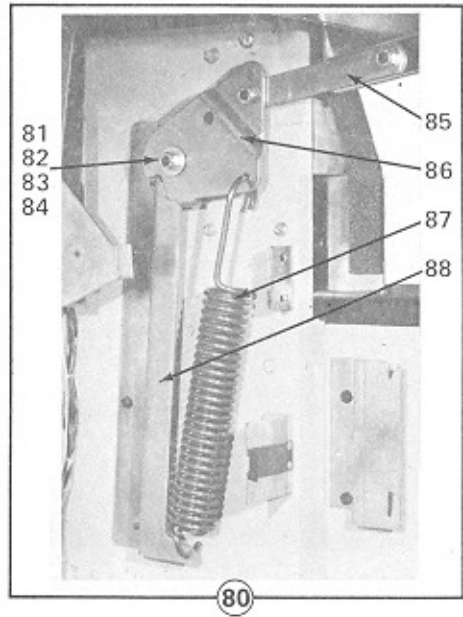
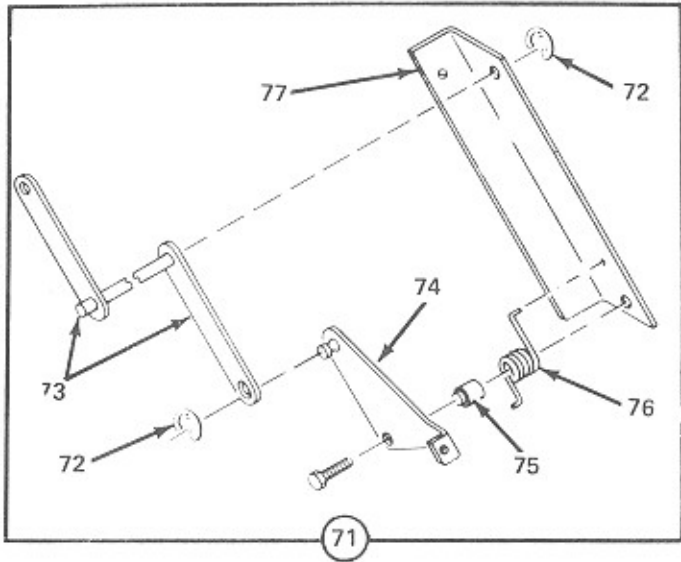
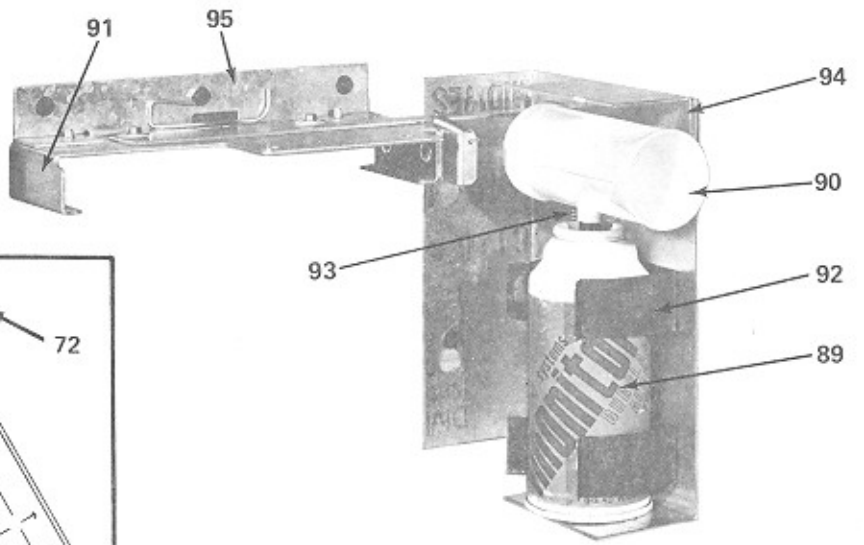

FIG. AND INDEX NO.	ROWE PART NO.	DESCRIPTION	QTY. PER ASSY
1-	601-08200	Phonograph Final Assembly, Model R-81, Wood Style (Continued)	
1-	602-08200	Phonograph Final Assembly, Model R-81, Scene Style (Continued)	
51	200-14913	. Door Guide	2
52	201-17128	. Latch Assembly, R.H.	1
	201-17127	. Latch Assembly, L.H.	1
53	301-07437	. Coin Chute Collar	1
54	201-17544	. Coin Chute Gasket	1
55	402-06825	. Lower Coin Chute Assembly	1
56	202-13578	. Elastic Stop Nut	1
57	702-01200	. Flat Washer	1
58	202-17208	. Slug Cup Bracket	1
59	201-06463	. Slug Cup and Door Assembly	1
60	401-07034	. Slug Chute Assembly	1
61	201-17533	. Support Hinge	2
62	401-06961	. Slug Rejector (5¢, 10¢, 25¢)	1
	400-05476	. Slug Rejector (5¢, 10¢, 25¢, 50¢)	OPT
63	401-07038	. Mounting Bracket and Coin Switch Assembly	1
64	201-08795	. Retainer Bracket	1
65	302-05787	. Coin Switch Assembly	1
66	201-14314	. Plate and Pin Assembly	1
67	201-17179	. Rejector Hinge	1
68	401-05793	. Slug Rejector Mounting Bracket Assembly	1
69	201-14295	. Rejector Catch Assembly	1
70	201-17140	. Alignment Bracket	1
71	401-06830	. Scavenge Assembly	1
72	704-01430	. Retaining Ring	2
73	201-17566	. Pivot Assembly	1
74	201-17591	. Link and Pin Assembly	1
75	201-17562	. Spacer	1
76	201-17565	. Torsion Spring	1
77	201-17550	. Scavenge Bracket	1
78	201-17555	. Scavenge Bracket	1
79	704-01430	. Retaining Ring	1
80	301-07622	. Spring Assembly	1
81	204-13578	. Elastic Stop Nut	1
82	708-01214	. Flat Washer	2
83	200-13900	. Lever Pin	1
84	719-01208	. Flat Washer	1
85	202-15671	. Spring Link	1
86	201-17725	. Spring Lever	1
87	301-06994	. Spring	1
88	301-07621	. Spring Support	1
	201-15303	. Burglar Alarm Kit (Mounted inside cash box door)	OPT
89	201-17228	. Alarm Power Pack	1
90	301-07284	. Horn	1
91	401-06345	. Lever Assembly	1
	401-06344	. Horn Mounting and Actuator Assembly	1
92	201-51481	. Spring Clip	2
93	200-14024	. Handle Return Spring	1
94	201-15297	. Bracket and Actuator	1
95	402-06495	. Cash Bag Support	1

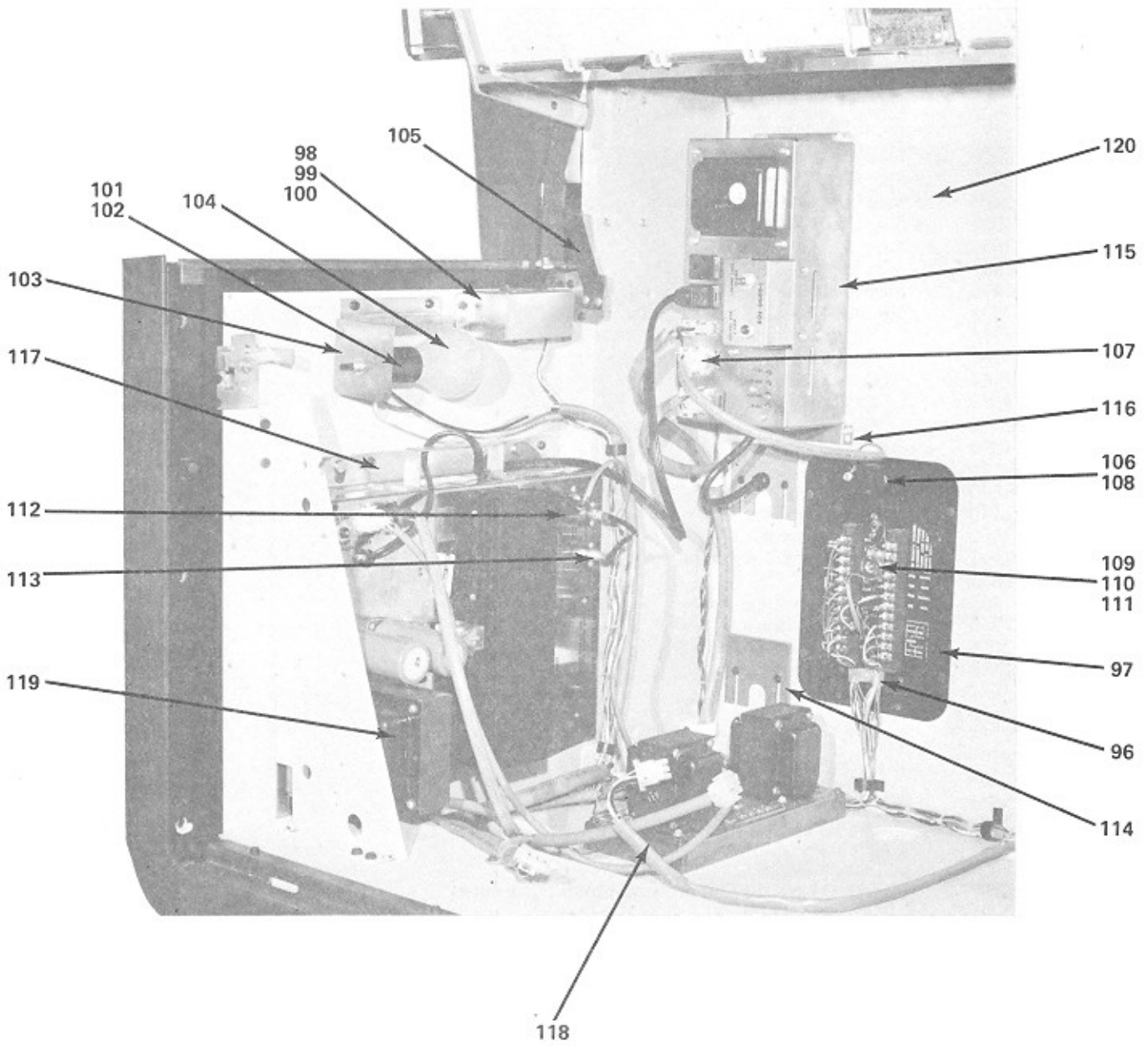

FIG. AND INDEX NO.	ROWE PART NO.	DESCRIPTION	QTY. PER ASSY
1-	601-08200	Phonograph Final Assembly, Model R-81, Wood Style (Continued)	
1-	602-08200	Phonograph Final Assembly, Model R-81, Scene Style (Continued)	
	702-00934	. Cable Clamp	16
	703-00931	. Cable Clamp	2
	705-00931	. Cable Clamp	4
	708-00931	. Cable Clamp	6
	602-07677	. Harness and Console Assembly	1
	201-17734	. . Lamp Socket (Credit Lamps)	2
	207-12844	. . 1 Circuit Molex Socket Housing (To Bill Acceptor)	1
	705-00755	. . 5 Circuit Connector Housing (To Selector Logic)	1
	718-00755	. . 18 Circuit Connector Housing (To Credit Computer)	1
	709-00755	. . 9 Circuit Connector Housing (To Selector Logic and To Memory Unit)	2
	707-00755	. . 7 Circuit Connector Housing (To Coin Switches)	1
	304-07491	. . 6 Circuit Universal Connector Plug Housing (To Mechanism)	1
96	704-00931	. . Cable Clamp	2
97	310-06792	. . Rear Access Door Assembly	1
	305-07491	. . 9 Circuit Universal Connector Plug Housing (To Power Supply and To External Speakers)	2
	201-13541	. . 7 Circuit Combo-Line Cap Housing (To Phono Speakers)	1
	204-13541	. . 7 Circuit Combo-Line Cap Housing (To Mute)	1
98	201-17731	. . Insulator	2
99	703-00931	. . Cable Clamp	1
100	301-07615	. . Switch Housing Assembly	1
	601-08284	. . 110V Harness Assembly	1
	302-07491	. . 3 Circuit Universal Connector Plug Housing (To Power Supply, Mechanism and Front Door)	3
101	201-15811	. . Light Socket	1
102	711-01220	. . Internal Tooth Lockwasher	1
103	301-07715	. . Light Shield	1
104	711-00604	. . 40W Lamp, Style A-19	1
105	201-17727	. . Spring Assembly	1
	205-17320	. . Plug and Switch Assembly	1
106	204-13081	. . Cord and Switch Assembly (SPST)	1
107	304-07491	. . 6 Circuit Universal Connector Plug Housing (To Power Supply)	1
108	200-00490	. . Internal Tooth Lockwasher	1
109	200-01799	. . Volume Control Knob	1
110	200-02649	. . Palnut	1
111	201-13935	. . Volume Control and Terminal Assembly	1
112	205-14101	. . Cable and Plug Assembly	1
113	203-09257	. . Tone Arm Cable and Plug Assembly	1
114	201-17593	. . Cord Hole Cover	1
115	401-06894	. . Main Power Supply (See Figure 16)	1
116	200-09256	. . Junction Box Mounting Bracket	1
	201-08795	. . Retainer Bracket (Not Shown - mounted on outside rear of cabinet)	2
117	401-02426	. . Amplifier Mounting Bracket Assembly	1
	606-02182	. . 64W Stereo Amplifier and Transformer Assembly	1
118	404-06322	. . 64W Output Transformer Assembly (See Figure 17)	1
119	601-02179	. . 64W Stereo Amplifier Assembly	1
	602-03758	. . . Pre-Amplifier Assembly (See page 2-82 for Parts List)	1
	601-02193	. . . 64W Power Amplifier (See page 2-81 for Parts List)	1
120	601-08250	. . Shell Assembly (See Figure 18)	1

FIGURE
2

Selector Assembly

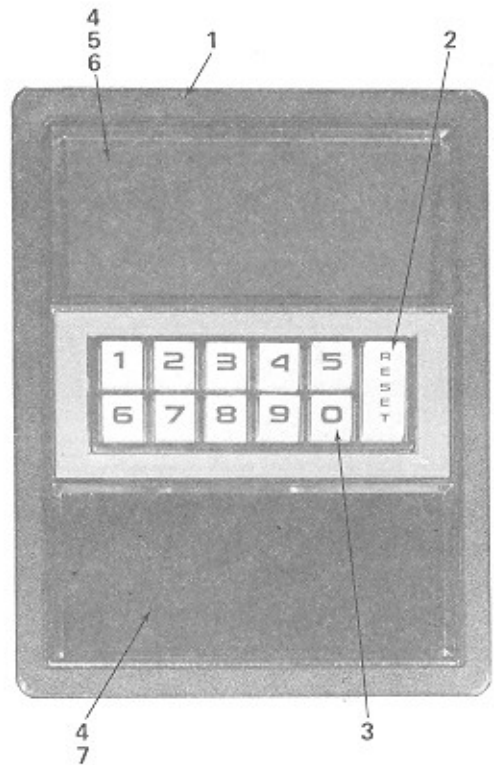
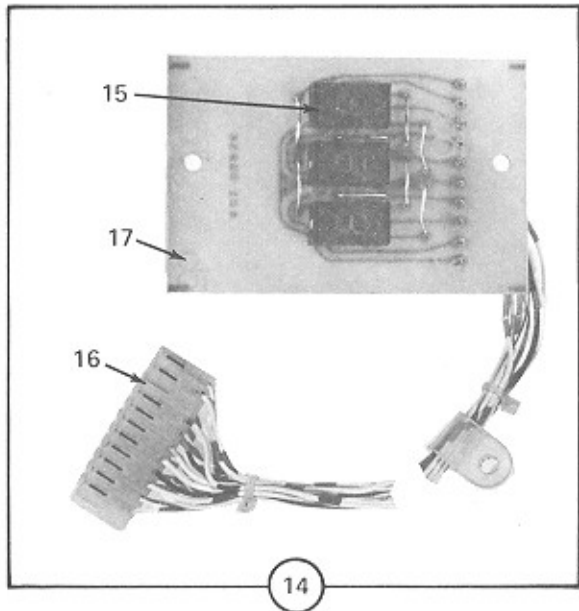
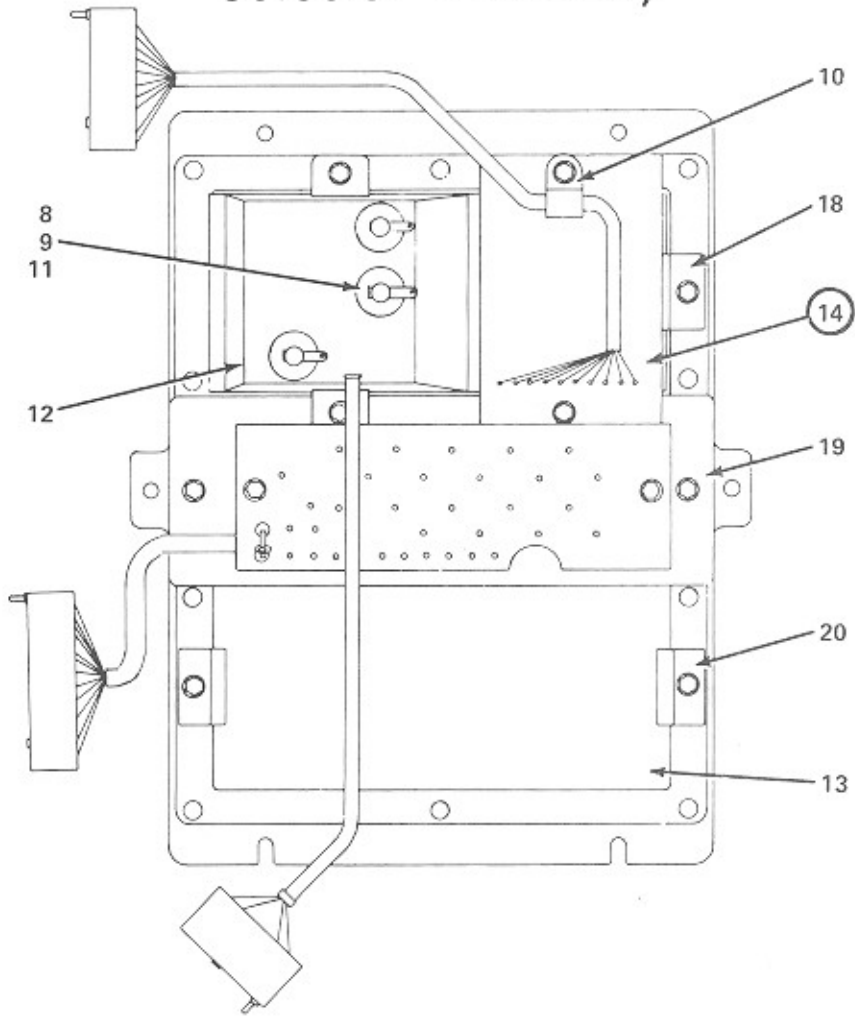

FIG. AND INDEX NO.	ROWE PART NO.	DESCRIPTION	QTY. PER ASSY
2-	602-07675	Selector Assembly (Figure 1, Item 2)	REF
1	402-06889	. Selector Panel Insert Assembly	1
2	302-07432	. Reset Pushbutton	1
3		. Number Series Pushbutton (1 Each of the Following:)	
	301-07711	"1" 305-07711 "5" 308-07711 "8"	
	302-07711	"2" 306-07711 "6" 309-07711 "9"	
	303-07711	"3" 307-07711 "7" 310-07711 "0"	
	304-07711	"4"	
4	201-17663	. Window Glass (6" x 2-3/4" x .115/.133" Thick Double Strength "B" Glass)	2
5	202-17678	. Digital Display Card (Part of Final Assembly)	1
6	201-17819	. Light Filter, Display Card	1
7	201-17821	. Solid State Card	1
8	200-50763	. 6.3V Pilot Lamp	3
9	201-17830	. Light Shield	2
10	703-00931	. Cable Clamp	1
	303-07557	. Selector Light Harness Assembly	1
11	201-17734	. . Lamp Socket	3
	706-00755	. . 6 Circuit P.C. Wafer Housing	1
12	402-06872	. Digital Display Light Housing	1
13	201-17822	. Backup Pad	1
14	401-06904	. Digital Display	1
15	201-17667	. . LED Display (LED's on each board must be all from same manufacturer)	3
16	301-07538	. . Digital Indicator Harness Assembly	1
17	401-06856	. . Digital Display Printed Wiring Board	1
18	201-17584	. Window Clamp	1
19	401-06898	. Keyboard Assembly	1
20	201-17594	. Retainer	2

FIGURE
3

Selector and Speaker Panel Assembly

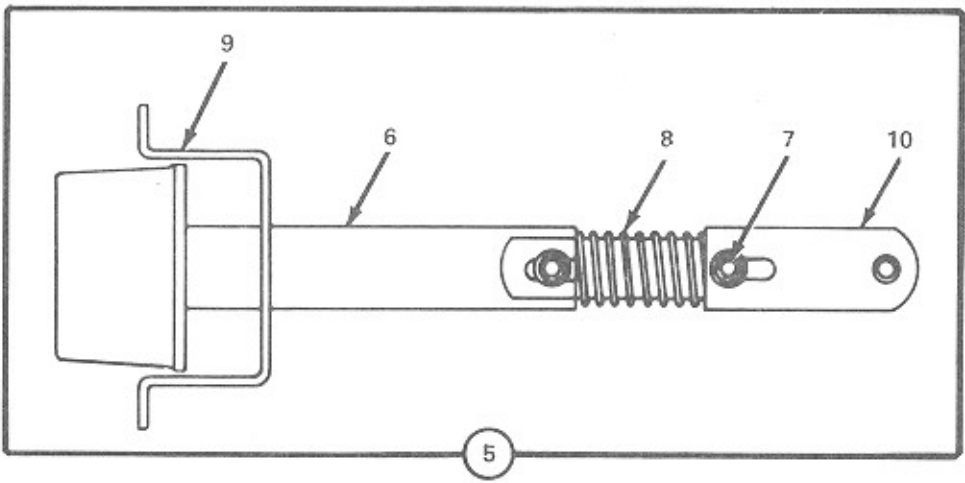
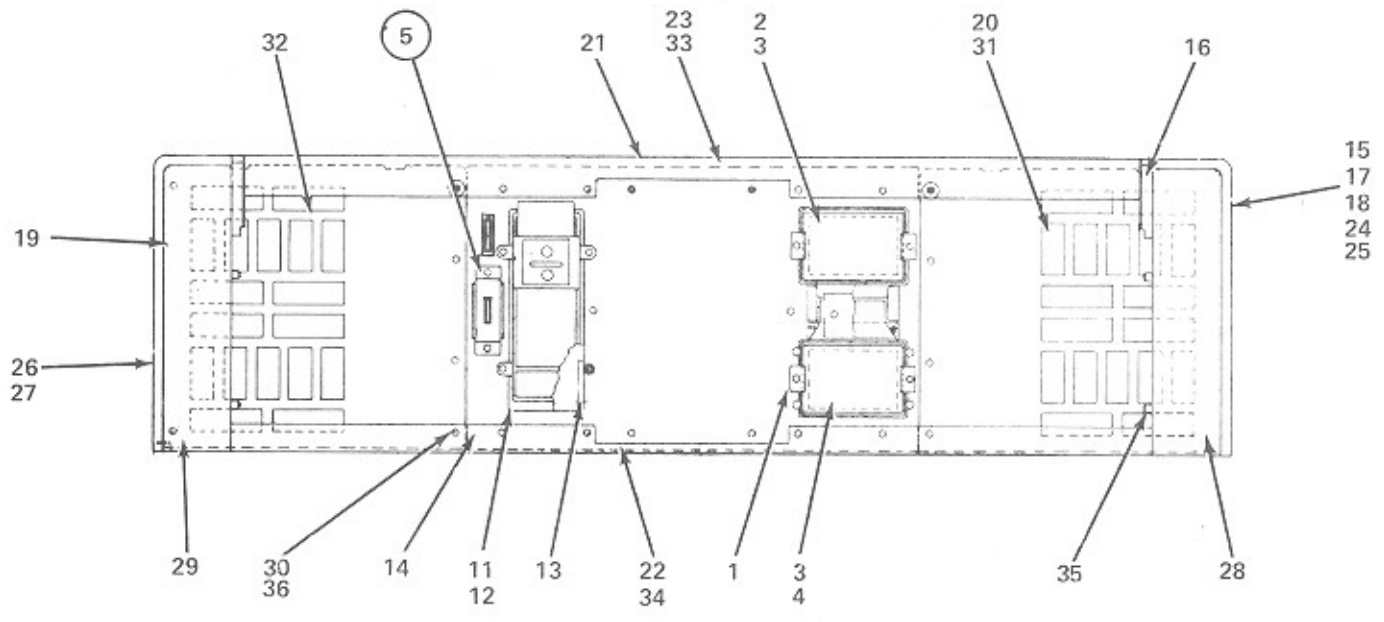

FIG. AND INDEX NO.	ROWE PART NO.	DESCRIPTION	QTY. PER ASSY
3-	601-08273	Selector and Speaker Panel Assembly (Figure 1, Item 3)	REF
1	201-17594	. Retainer	4
2	201-17510	. Product Identification Panel	1
3	201-17509	. Legend Window (4" x 2-3/4" x 0.115/0.133" Thk. "B" Glass, Double Strength)	2
4	202-17511	. Stereo Panel	1
5	301-07471	. Shaft and Stop Assembly	1
6	201-17507	. . Button and Shaft Assembly	1
7	202-09225	. . Spacer	2
8	201-17656	. . Compression Spring	1
9	301-07411	. . Stop Bracket	1
10	201-17564	. . Shaft and Pin Assembly	1
11	601-07673	. Light Housing	1
12	301-07412	. Price Card Window (7-7/8" x 2-7/8" x 0.115/0.133" Thk. Double Strength "B" Glass	1
13	722-02123	. Cork Composition Strip	4
14	301-07705	. Selector Coin Inlet Assembly	1
15	201-17801	. Corner Bracket	2
16	401-07009	. L.H. Top Panel Retainer	1
16	401-07010	. R.H. Top Panel Retainer	1
17	601-08261	. Side Grille	2
18	301-07709	. Side Grille Backing	2
19	601-08255	. R.H. Corner Speaker Trim	1
19	601-08254	. L.H. Corner Speaker Trim	1
20	401-07020	. Front Grille	2
21	601-08259	. Upper Trim Bar	1
21	601-08260	. Lower Trim Bar	1
22	301-07706	. Grille Strip	1
23	302-07706	. Grille Strip	1
24	701-01130	. Roll Pin, 0.131/0.135" O.D. x 13/16" Lg.	2
25	702-01130	. Roll Pin, 0.194/0.199" O.D. x 5/8" Lg.	2
26	601-08253	. Side Speaker Trim	2
27	710-02204	. Foamed Tape, 1/4" x 1/8" x 40-1/2" Lg.	1
28	201-17802	. L.H. Bracket Assembly	1
29	201-17803	. R.H. Bracket Assembly	1
30	201-17501	. Stud	4
31	301-07707	. L.H. Backup Plate with Studs	1
32	301-07708	. R.H. Backup Plate with Studs	1
33	301-07704	. Backup Strip	2
34	302-07704	. Backup Strip	2
35	202-15726	. Fall Stop Cable	1
36	710-01200	. Washer, 0.203" I.D. x 5/8" O.D. x 0.063" Thk.	2

FIGURE
4

Top Door Assembly

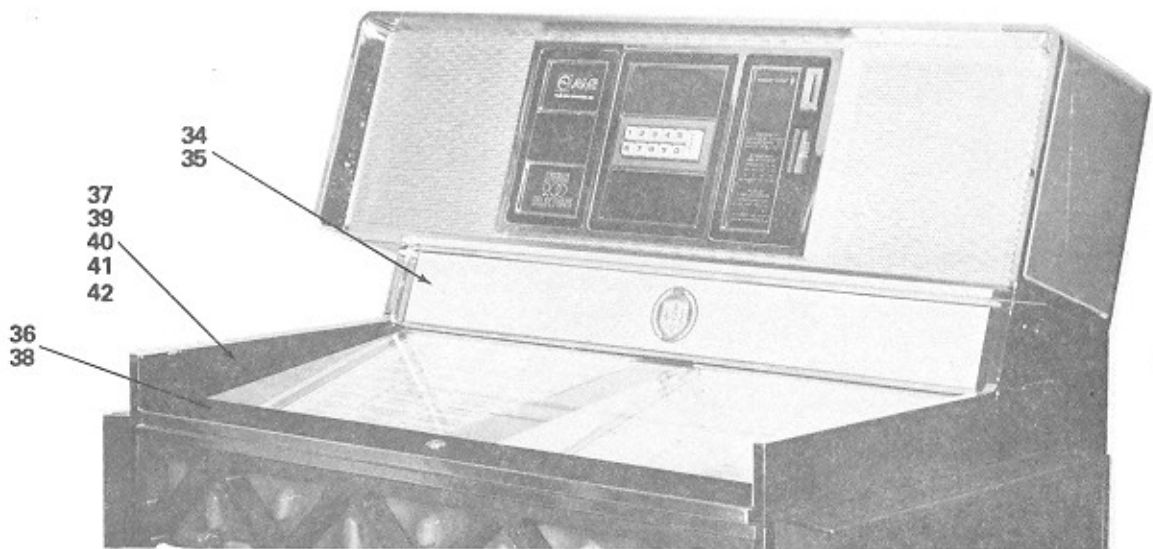
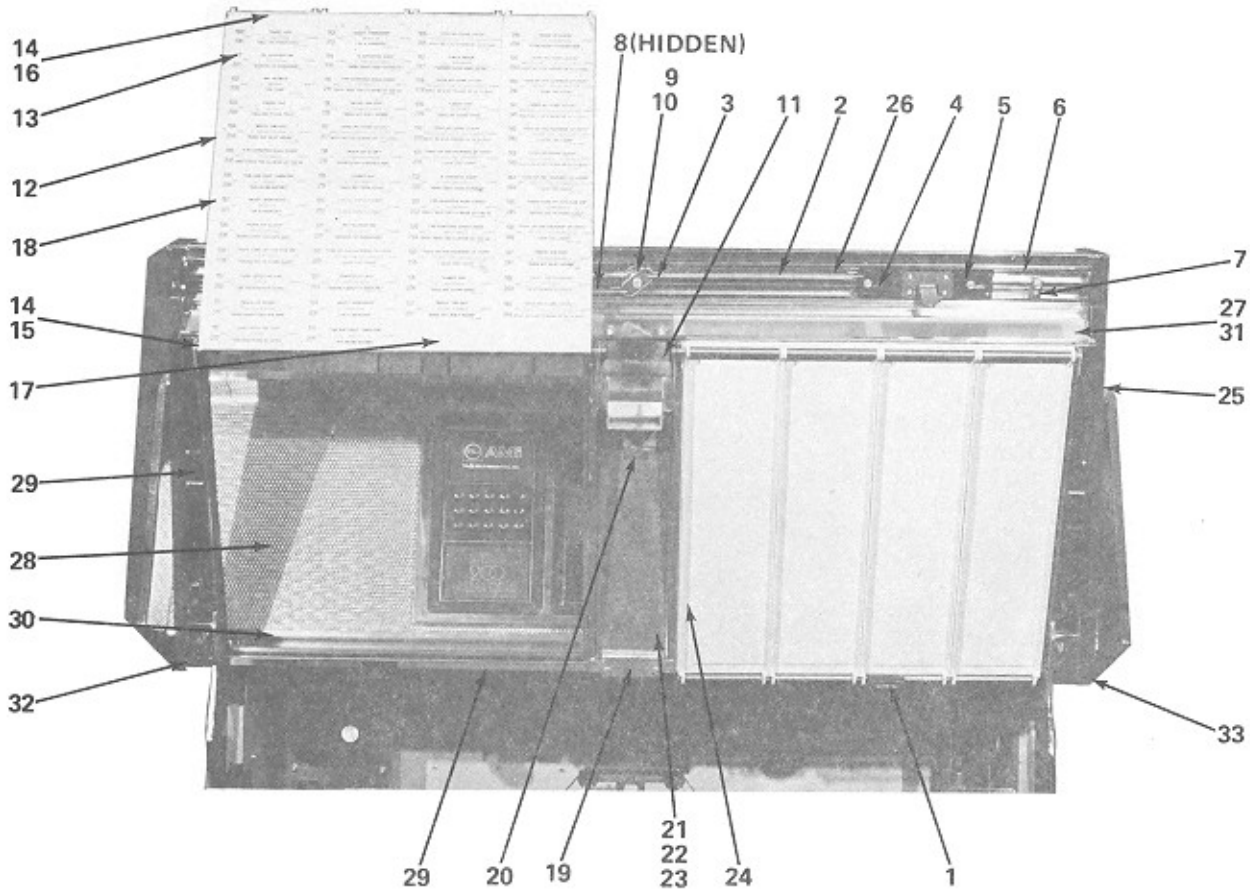

FIG. AND INDEX NO.	ROWE PART NO.	DESCRIPTION	QTY. PER ASSY
4-	601-08277	Top Door Assembly (Figure 1, Item 4)	REF
1	201-17518	. Title Panel Spring Catch	2
2	201-17657	. Lock Bar Link	2
3	200-14256	. Lock Bolt	1
4	202-09225	. Spacer	4
5	201-17515	. Lock Bar Assembly, R.H.	1
	201-17514	. Lock Bar Assembly, L.H.	1
6	200-12562	. Spring	2
7	201-15674	. Spring Retainer	2
8	201-17532	. Guide	1
9	725-01208	. Washer	1
10	719-01630	. Common Keying Cylinder Lock	1
11	201-17517	. Pivot Bracket and Spring Assembly	1
12	402-06820	. Title Panel Assembly, L.H.	1
	402-06821	. Title Panel Assembly, R.H.	1
13	301-07493	. . Number Strip, 100 to 212 (On 402-06820)	1
	302-07493	. . Number Strip, 113 to 225 (On 402-06820)	1
	303-07493	. . Number Strip, 126 to 237 (On 402-06820)	1
	304-07493	. . Number Strip, 138 to 249 (On 402-06820)	1
	305-07493	. . Number Strip, 150 to 261 (On 402-06821)	1
	306-07493	. . Number Strip, 162 to 273 (On 402-06821)	1
	307-07493	. . Number Strip, 174 to 286 (On 402-06821)	1
	308-07493	. . Number Strip, 182 to 299 (On 402-06821)	1
14	703-01430	. . Retaining Ring	4
15	201-17519	. . Bottom Rod	1
16	201-17520	. . Top Rod	1
17	201-17628	. . Title Rack Insert	2
18	601-07571	. . Title Rack	4
19	201-17548	. Record Playing Frame Mounting Bracket	1
20	201-17554	. License Holder Retainer Bracket	1
21	201-17551	. License Holder Backing	1
22	201-17552	. License Cover	1
23	201-17815	. License Card	1
24	601-07564	. Record Playing Frame	1
24A	201-17813	. Opening Cover	1
25	708-02204	. Foamed Tape (Door Sides)	2
26	711-02204	. Foamed Tape (Front)	1
27	201-17516	. Diffuser	2
28	301-07416	. Top Door Window (15-11/32" x 34-5/8" x .178/.198 Thk. Fully Tempered Clear Glass)	1
29	725-02203	. Foamed Tape	1
30	210-15794	. Channel, 34-3/8" Long	2
31	721-02203	. Foamed Tape	1
32	201-17814	. Light Block and Reset Assembly	1
33	203-17541	. Light Block	1
34	401-07012	. Back Trim Insert	1
35	401-06808	. Back Trim	1
36	401-07016	. Front Trim	1
37	301-07701	. R.H. Door Support Side	1
37	301-07702	. L.H. Door Support Side	1
38	301-07712	. Front Trim Overlay	1
39	601-08270	. L.H. Door Support	1
39	601-08271	. R.H. Door Support	1
40	601-08274	. L.H. Door Support Side Inlay	1
40	601-08275	. R.H. Door Support Side Inlay	1
41	201-17811	. Washer	6
42	708-01355	. Palnut	6

FIGURE
5

Front Door Assembly

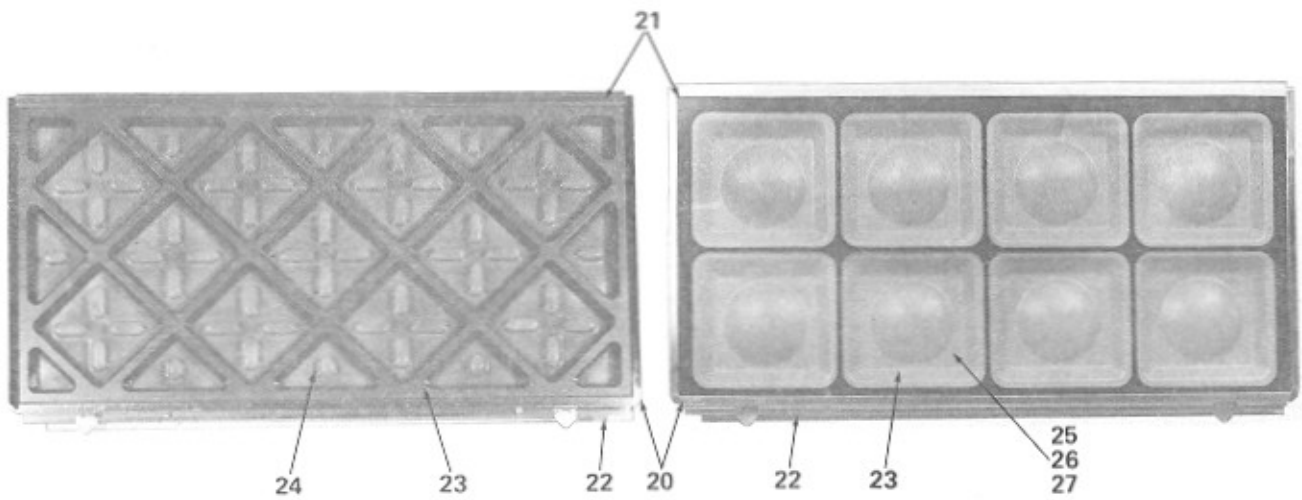
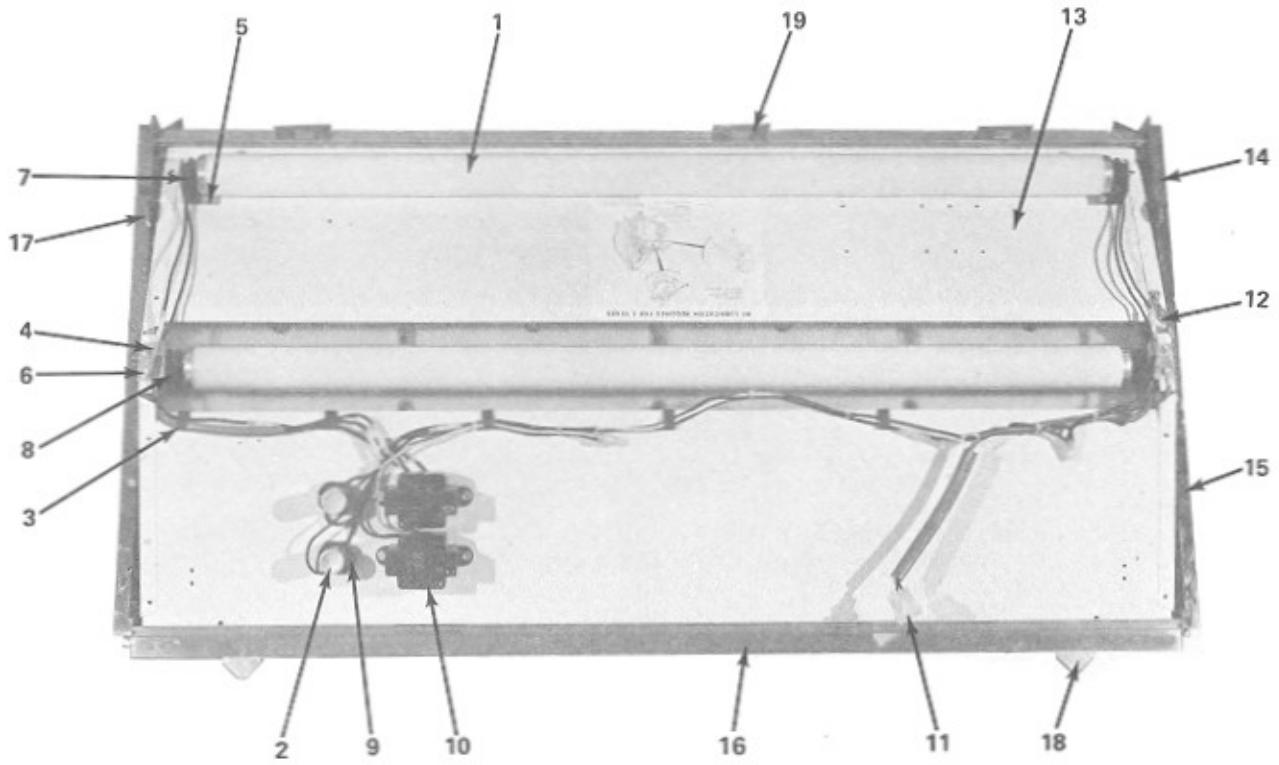

FIG. AND INDEX NO.	ROWE PART NO.	DESCRIPTION	QTY. PER ASSY
5-	601-08278	Front Door Assembly, Wood Style (Figure 1, Item 7)	REF
5-	602-08278	Front Door Assembly, Scene Style (Figure 1, Item 7)	REF
1	706-00601	. Fluorescent Lamp, 25W, 33 inches, Type T-12	2
2	703-00800	. Fluorescent Starter, FS-25	2
	601-08279	. Reflector Panel and Harness Assembly	1
3	200-07545	. Wire Clip	6
4	703-00931	. Cable Clamp	2
	401-07025	. Front Door Harness Assembly	1
5	201-15676	. Upper Lamp Bracket	2
6	201-17159	. Lower Lamp Bracket	2
7	207-15808	. Upper Fluorescent Lampholder	2
8	208-15808	. Lower Fluorescent Lampholder	2
9	200-00295	. Starter Socket	2
10	200-13801	. 25W Ballast	2
11	302-07490	. 3 Circuit Universal Connector Cap Housing	1
12	201-17816	. Fall Stop	1
13	401-07024	. Reflector Panel Assembly	1
14	713-02204	. Foamed Tape	2
15	714-02204	. Foamed Tape	2
16	715-02204	. Foamed Tape	1
17	201-17116	. Catch	2
18	201-17804	. Pivot Bracket	2
19	202-17537	. Strike Plate	3
20	601-08257	. L.H. Door Side	1
20	601-08258	. R.H. Door Side	1
21	401-07014	. Top Trim	1
22	401-07013	. Bottom Trim	1
23	601-08266	. Front Door Trim (Wood Style Only)	1
23	601-08269	. Front Door Scene (Scene Style Only)	1
24	601-08267	. Wood Trim Insert (Wood Style Only)	1
25	201-14301	. Window Channel, 35-1/2" Long (Top and Bottom)	2
26	206-14301	. Window Channel, 17-1/2" Long (Sides)	2
27	301-07703	. Front Door Window (18" x 36-3/32" x .110/.140" Thk. Full Tempered Clear Glass)	1

**FIGURE
6**

Side Panel Assembly

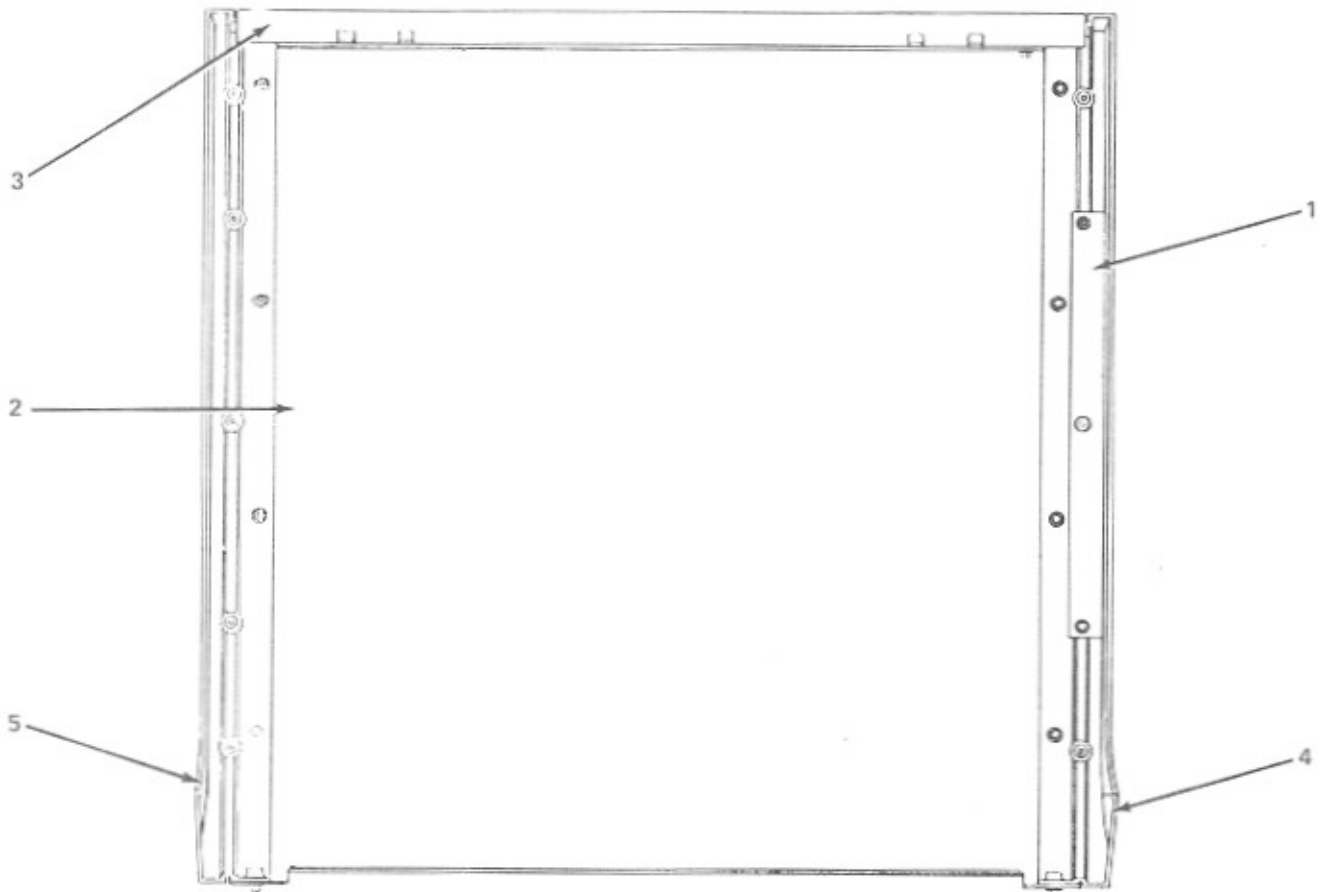

FIG. AND INDEX NO.	ROWE PART NO.	DESCRIPTION	QTY. PER ASSY
6-	601-08280	Side Panel Assembly, L.H. (Figure 1, Item 9)	REF
6-	601-08281	Side Panel Assembly, R.H. (Figure 1, Item 9)	REF
1	301-07430	. Side Frame Retaining Bracket	1
2	401-07022	. L.H. Panel and Stud Assembly (Left Side Only)	1
2	401-07023	. R.H. Panel and Stud Assembly (Right Side Only)	1
3	401-07000	. Side Overlay Top	1
4	601-08251	. L.H. Side Trim	1
5	601-08252	. R.H. Side Trim	1

Top Access Door Assembly

FIGURE
7

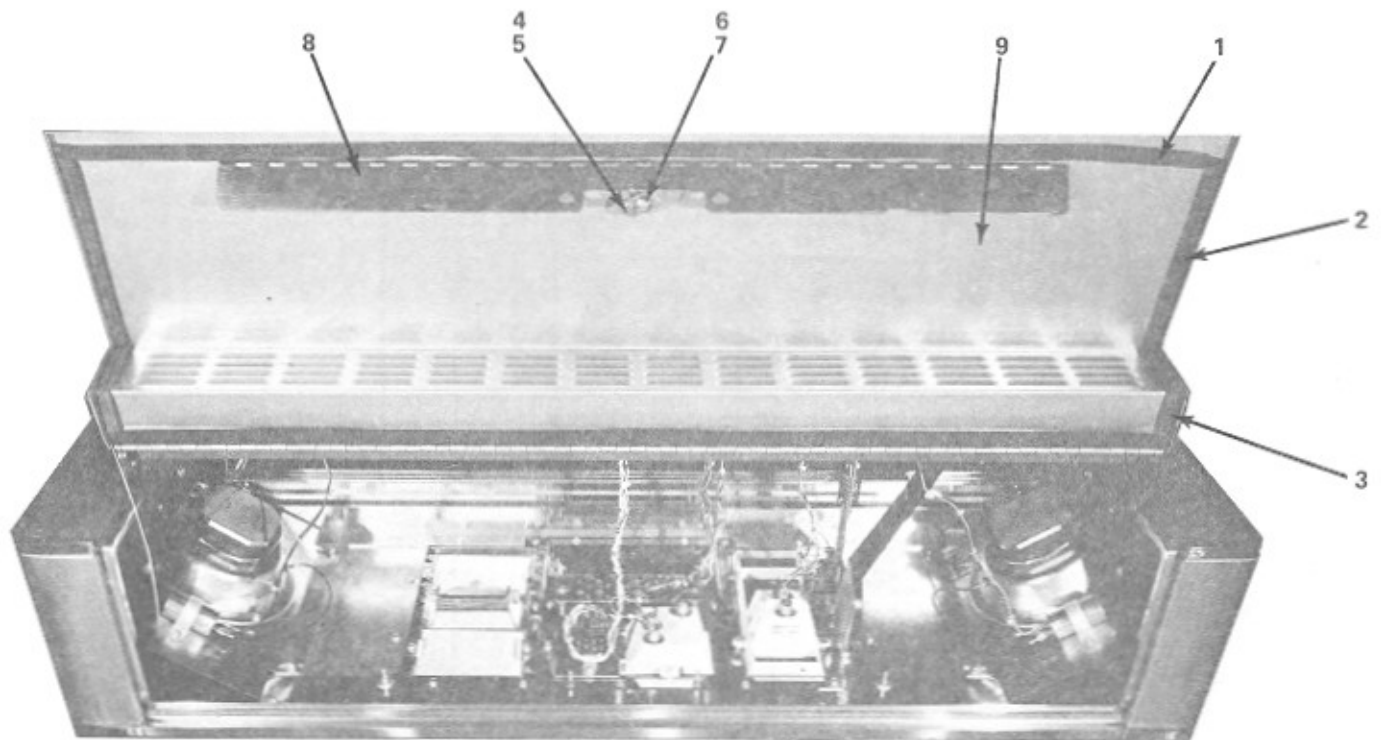

FIG. AND INDEX NO.	ROWE PART NO.	DESCRIPTION	QTY. PER ASSY
7-	601-08272	Top Access Door Assembly (Figure 1, Item 11)	REF
1	722-02203	Tape, Foam	1
2	725-02129	Tape, Foam	2
3	703-02121	Tape, Foam	1
4	703-01430	Ring, Retaining	1
5	201-15718	Link, Latch Bar	1
6	202-14228	Lock Bolt Assembly	1
7	719-01630	Lock, Cylinder, Common Keying	1
8	401-07011	Hinge, Latch	1
9	601-08276	Top Door Weld Assembly	1

FIGURE
8

Mechanism Assembly Sheet 1

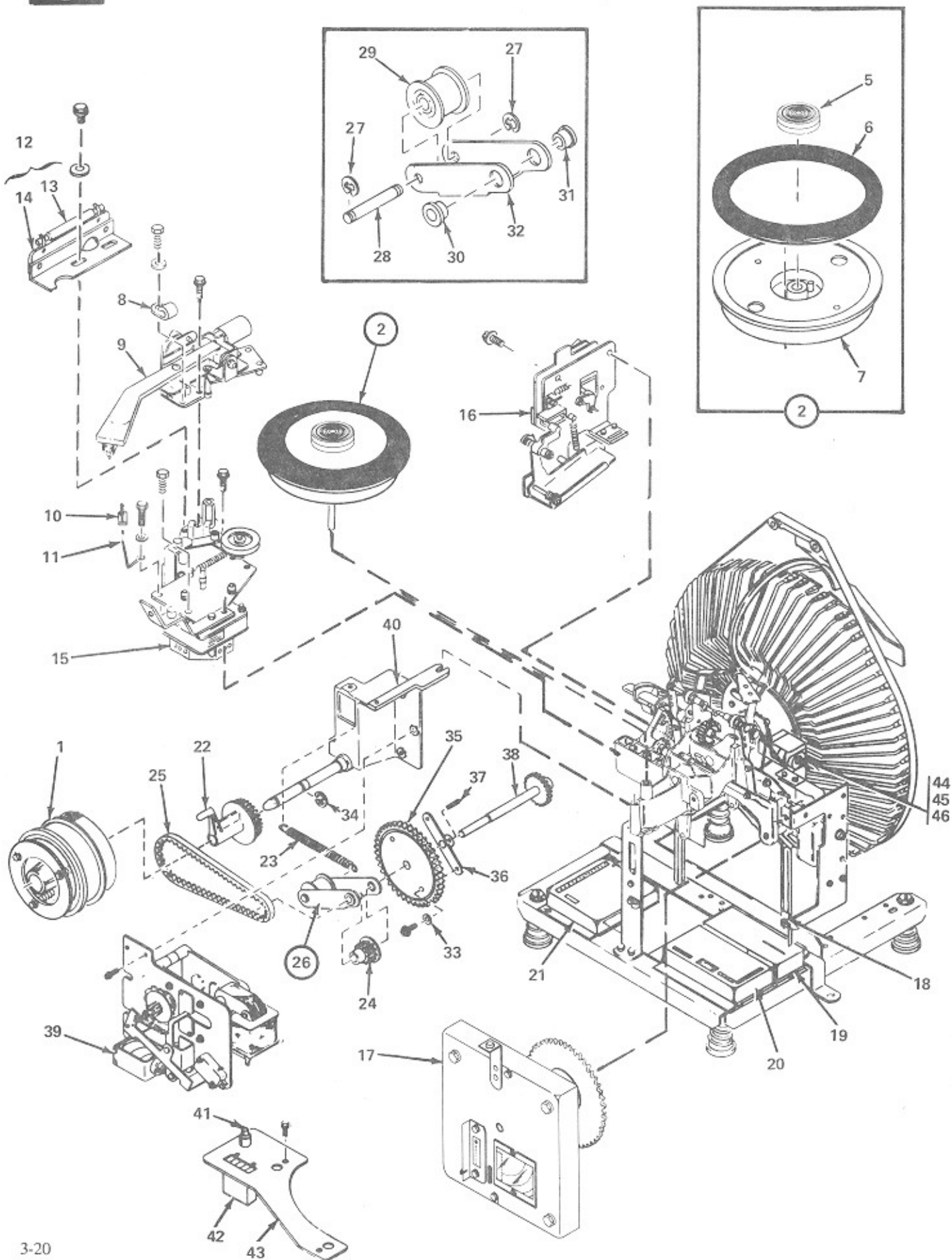

FIG. AND INDEX NO.	ROWE PART NO.	DESCRIPTION	QTY. PER ASSY
8-	601-03065	Mechanism Assembly (Figure 1, Item 24)	REF
1	305-05465	. Playmeter Wheel Assembly (See Figure 9)	1
2	301-05238	. Turntable Assembly	1
3	Not Used		
4	Not Used		
5	401-05068	. . Hub	1
6	301-05235	. . Turntable Face	1
7	402-05069	. . Turntable and Shaft Assembly	1
8	701-00931	. Cable Clamp	1
9	306-05124	. Tone Arm Assembly (See Figure 10)	1
10	200-02182	. Brush	1
11	200-11569	. Brush Clip	1
12	201-10891	. Cutoff Switch Assembly	1
13	200-10726	. . Reed Switch	1
14	201-10917	. . Terminal Board and Bracket Assembly	1
15	404-05074	. Turntable Motor and Plate Assembly (See Figure 11)	1
16	401-06906	. Cam Switch and Motor Assembly (See Figure 12)	1
17	601-07667	. Encoder Assembly (See Figure 13)	1
18	200-11587	. 1/4-20 Speednut	2
19	301-07541	. D.C. Converter(See Figure 14)	1
20	601-07666	. Memory Unit (See phonograph schematic in Part 2 for parts)	1
21	401-06905	. Mechanism Control Unit (See phonograph schematic in Part 2 for parts)	1
22	300-05149	. Playmeter Pulley	1
23	200-10896	. Tension Spring	1
24	200-10880	. Pulley	1
25	201-10878	. Timing Belt	1
26	201-11012	. Idler Bracket Assembly	1
27	703-01430	. . Retaining Ring	2
28	200-10879	. . Idler Pin	1
29	200-03843	. . Belt Roller	1
30	707-01460	. . Bearing	1
31	706-01460	. . Bearing	1
32	200-10877	. . Idler Bracket	1
33	704-01222	. External Tooth Lockwasher	2
34	702-01430	. Retaining Ring	1
35	301-05181	. Pinion and Plate Assembly	1
36	200-10826	. Gear Hub	1
37	706-01130	. Roll Pin	2
38	201-11000	. Magazine Drive Shaft Assembly	1
39	405-05022	. Sprag Assembly (Magazine Motor) (See Figure 15)	1
40	301-05125	. Motor Bracket Assembly	1
41	201-15818	. Momentary Contact Switch, Pushbutton Type	1
42	201-17721	. Counter Assembly	1
43	301-05242	. Counter Mounting Plate	1
44	201-17716	. Tip and Plunger Assembly	1
45	206-11505	. Solenoid Assembly	1
46	201-17669	. Solenoid Bracket	1

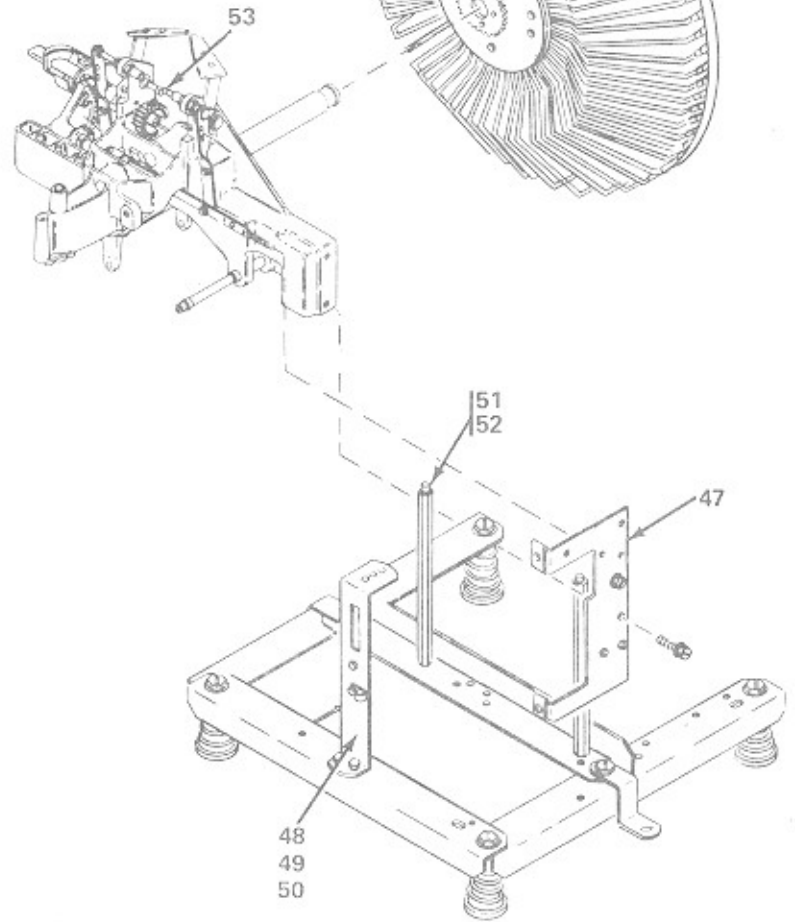
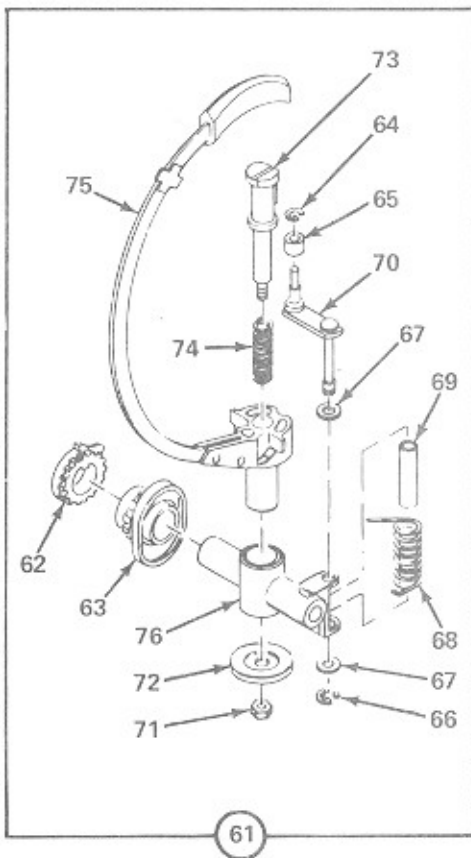
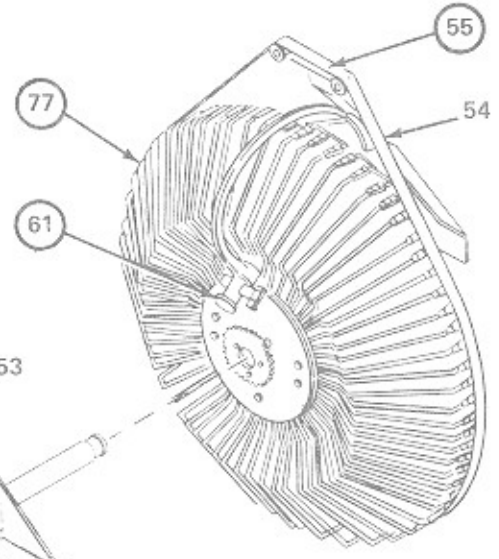
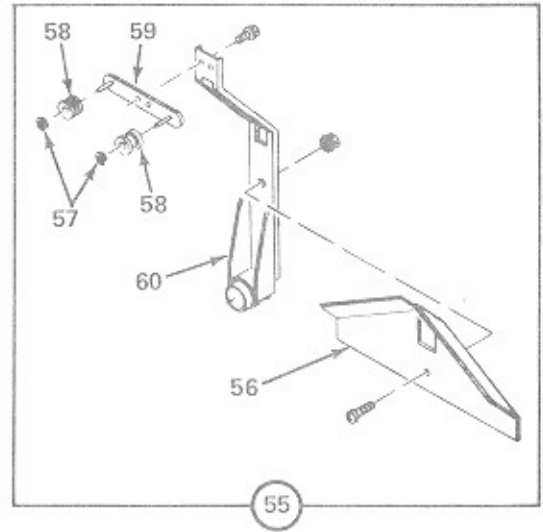
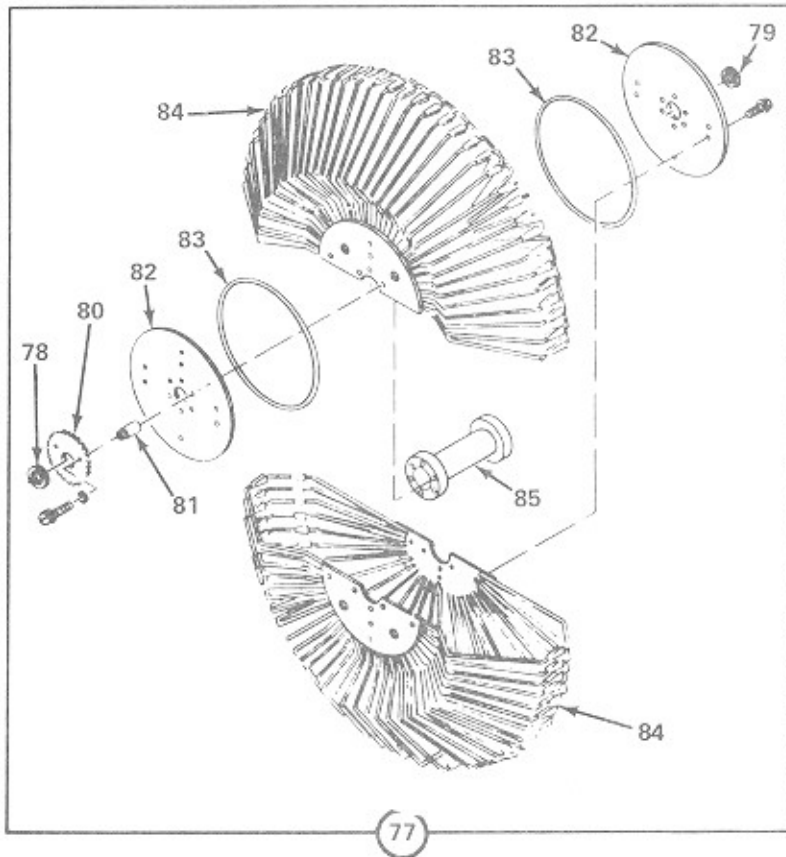

FIG. AND INDEX NO.	ROWE PART NO.	DESCRIPTION	QTY. PER ASSY
8-	601-03065	Mechanism Assembly (Continued)	
47	302-07489	. Encoder Unit Mounting Bracket	1
48	200-07545	. Wire Clip	4
49	200-10864	. Mounting Bracket	1
50	200-11014	. Locknut	2
51	200-10881	. Mechanism Support	2
52	200-11013	. Locknut	2
53	200-10792	. Trunnion Pin	2
54	201-10895	. Belt	1
55	303-05169	. Guide and Belt Support Assembly	1
56	400-05049	. . Record Stop	1
57	703-01430	. . Retaining Ring	2
58	200-03843	. . Roller	2
59	200-10894	. . Roller Bracket Assembly	1
60	301-05147	. . Gripper Bow Assembly	1
61	401-05390	. Gripper Bow and Trunnion Assembly	1
62	300-05122	. . Trunnion Gear	1
63	400-05013	. . Cam Gear	1
64	707-01430	. . Retaining Ring	1
65	200-12537	. . Roller	1
66	703-01430	. . Retaining Ring	1
67	721-01207	. . Flat Washer	2
68	200-12538	. . Torsion Spring	1
69	200-12536	. . Sleeve Bearing	1
70	201-12532	. . Pawl Lever and Shaft Assembly	1
71	210-13578	. . Stop Nut	1
72	201-10815	. . Cam Follower	1
73	201-10808	. . Inner Shoe	1
74	200-10811	. . Record Release Spring	1
75	301-05197	. . Transfer Arm and Hub Assembly	1
76	301-05121	. . Trunnion	1
77	603-03010	. Magazine Assembly	1
78	714-01460	. . Bearing	1
79	701-01460	. . Bearing	1
80	300-05191	. . Gear	1
81	200-11518	. . Spacer	3
82	300-05100	. . Separator Support	2
83	200-10803	. . Cord Ring	2
84	402-05044	. . Separator Assembly	2
85	300-05101	. . Support Spacer	1

FIGURE 8

Mechanism Assembly Sheet 3

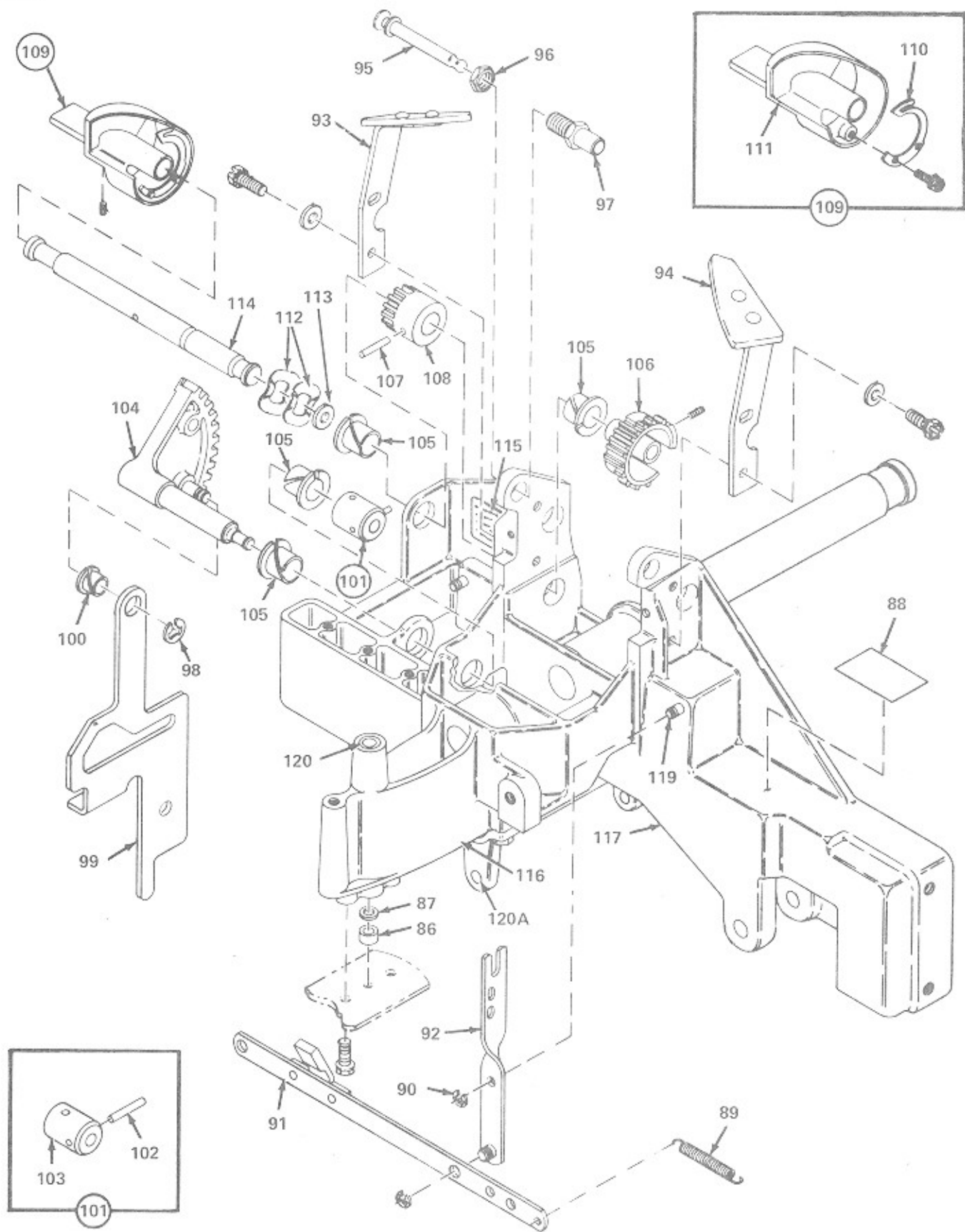

FIG. AND INDEX NO.	ROWE PART NO.	DESCRIPTION	QTY. PER ASSY
8-	601-03065	Mechanism Assembly (Continued)	
86	200-10866	. Spacer Bearing	1
87	200-10364	. Thrust Bearing	1
88	204-11004	. Mechanism Nameplate	1
89	200-10955	. Tension Spring	1
90	703-01430	. Retaining Ring	4
91	201-10823	. Cross Link and Stop Assembly	1
92	201-11517	. Link and Pin Assembly	2
93	201-11520	. Record Guide Assembly (L.H.)	1
94	201-11521	. Record Guide Assembly (R.H.)	1
95	200-11528	. Toggle Pin	2
96	704-01301	. Nut	2
97	200-10817	. Toggle Pin Bushing	2
98	704-01430	. Retaining Ring	1
99	200-10793	. Transfer Link	1
100	704-01460	. Bearing	1
101	201-10809	. Collar and Pin Assembly	1
102	720-01101	. . Roll Pin	1
103	200-10799	. . Collar	1
104	201-10800	. Segment Gear and Shaft Assembly	1
105	705-01460	. Bearing	4
106	400-05014	. Trunnion and Cam Drive Gear	1
107	719-01130	. Roll Pin	1
108	200-14175	. Camshaft Gear	1
109	201-10892	. Tone Arm Cam Assembly	1
110	200-10909	. . Spring	1
111	400-05008	. . Cam	1
112	733-01225	. Wave Washer	2
113	725-01208	. Plain Washer	1
114	200-10791	. Trunnion Drive Shaft	1
115	200-12665	. Label	1
116	404-05003	. Base Assembly	1
117	300-05205	. . Shaft Support	1
118	401-05002	. . Base and Shaft Support Assembly	1
119	200-10729	. . Mounting Pin	2
120	200-10377	. . Bearing	2
120A	702-01460	. Bearing	2

Mechanism Assembly Sheet 4

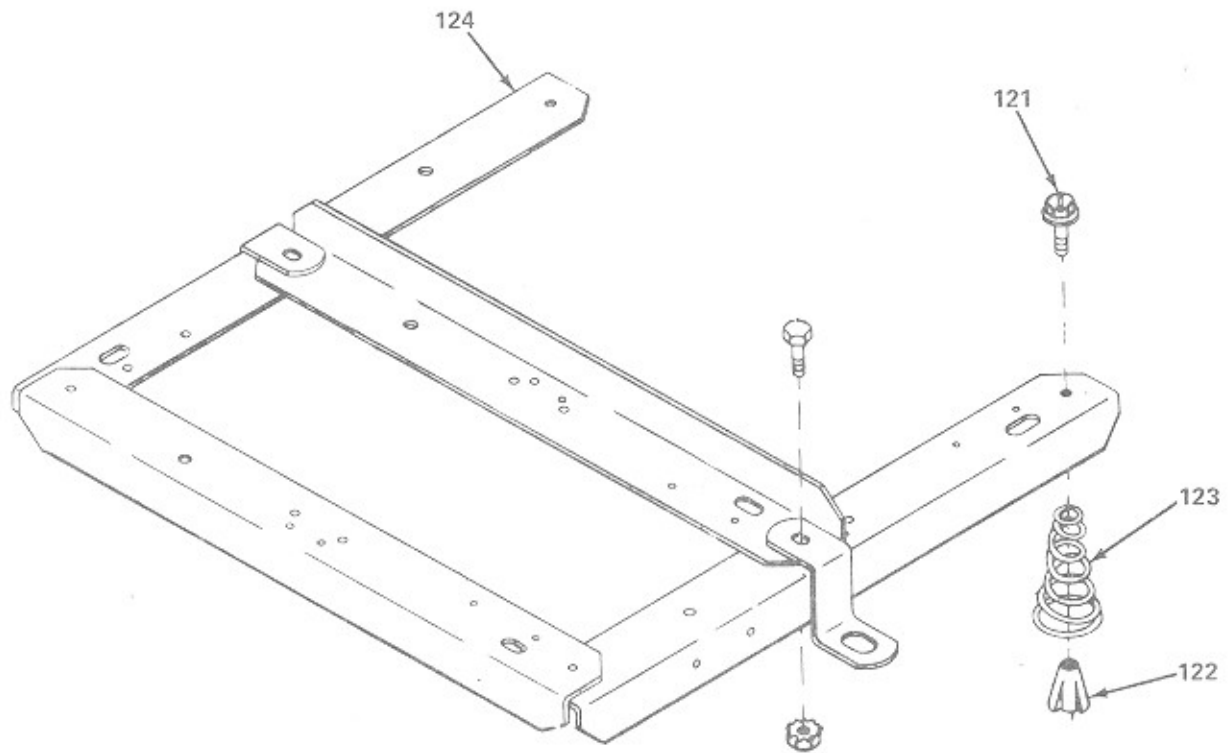

FIG. AND INDEX NO.	ROWE PART NO.	DESCRIPTION	QTY. PER ASSY
8-	601-03065	Mechanism Assembly (Continued)	
	303-06622	. . . Mechanism Support and Spring Assembly	1
121	200-11538	. . . Pin, Screw, Spring Support	4
122	200-06272	. . . Support, Spring	4
123	200-06128	. . . Spring	4
124	303-05142	. . . Mechanism Support Assembly	1

Playmeter Wheel Assembly

FIGURE
9

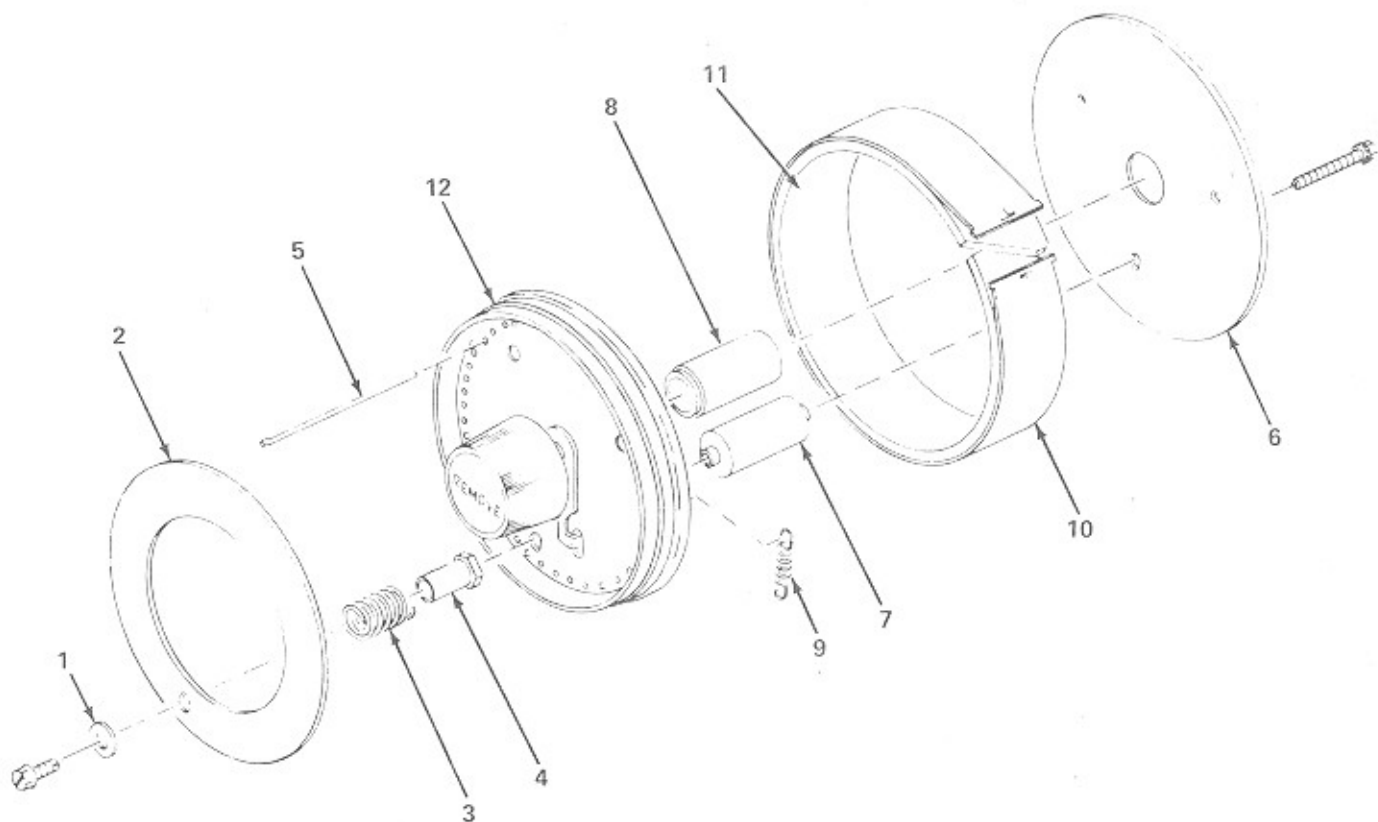

FIG. AND INDEX NO.	ROWE PART NO.	DESCRIPTION	QTY. PER ASSY
9-	305-05465	Playmeter Wheel Assembly (Figure 8, Item 1)	REF
1	702-01200	Washer, Flat, No. 6	3
2	300-06262	Plate, Reset	1
3	200-10965	Spring, Compression	3
4	200-10969	Stud, Reset Guide	3
5	200-11582	Pin, Playmeter	100
6	300-05159	Plate, Back	1
7	200-10962	Spacer	3
8	200-10968	Bearing	1
9	200-11581	Spring, Tension	1
10	301-07537	Strip, Playmeter	1
11	202-10966	Strip, Pin Loading	1
12	201-13913	Playmeter Plate Assembly	1

**FIGURE
10**

Tone Arm Assembly

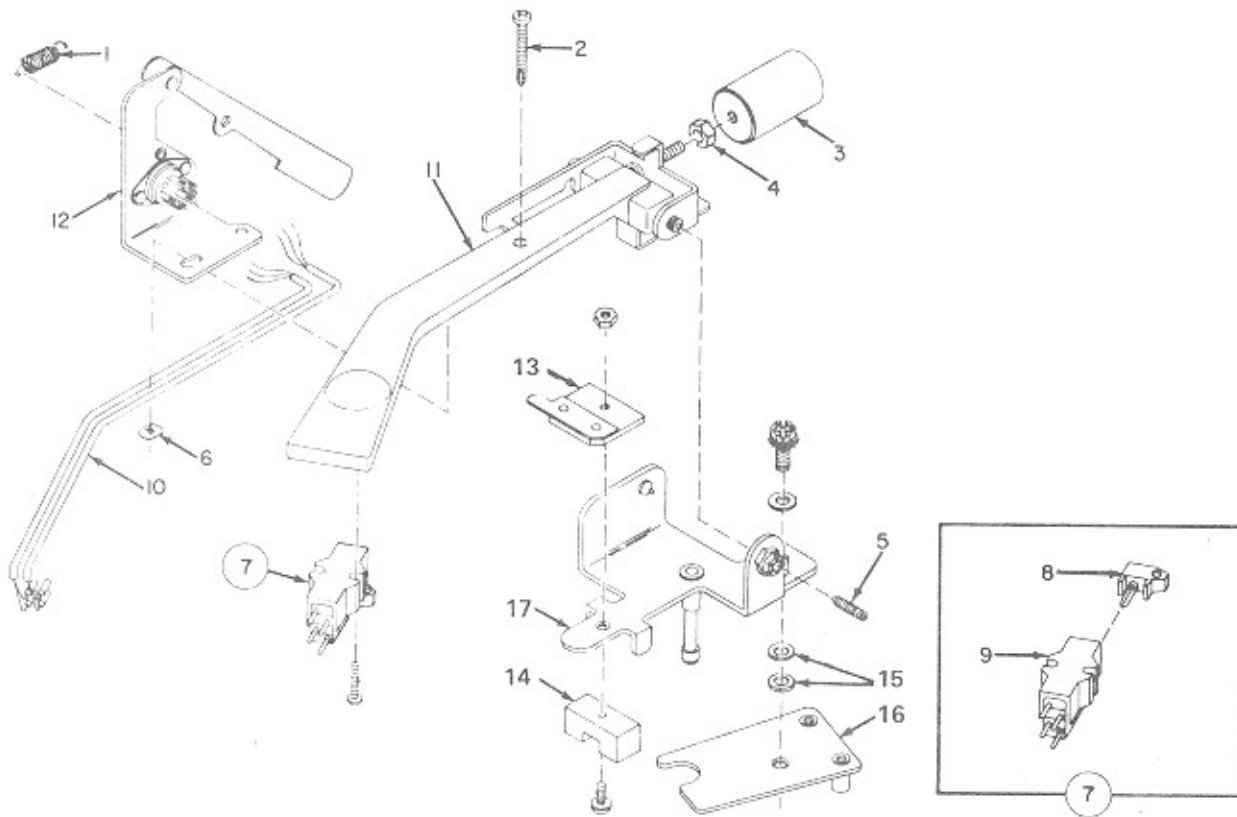

FIG. AND INDEX NO.	ROWE PART NO.	DESCRIPTION	QTY. PER ASSY
10-	306-05124	Tone Arm Assembly (See Figure 8, Item 9)	REF
1	200-03713	. Spring, Tension	1
2	200-65025	. Screw, Contact	1
3	201-11585	. Counterweight	1
4	200-13306	. Nut	1
5	200-10712	. Screw, Pivot	1
6	200-10898	. Nut, Push-On	3
7	200-13011	. Cartridge, Stereo	1
8	200-13031	. Stylus	1
9	200-10873	. Cartridge	1
10	201-10874	. Cable Assembly	2
11	303-05118	. Arm and Lever Assembly	1
12	201-10785	. Bracket and Lever Assembly	1
13	201-65023	. Blade, Contact	1
14	200-10724	. Magnet	1
15	719-01200	. Washer, Flat	AR
16	201-10727	. Cam Plate Assembly	1
17	201-10714	. Bracket and Shaft Assembly	1

Turntable Motor and Plate Assembly

**FIGURE
11**

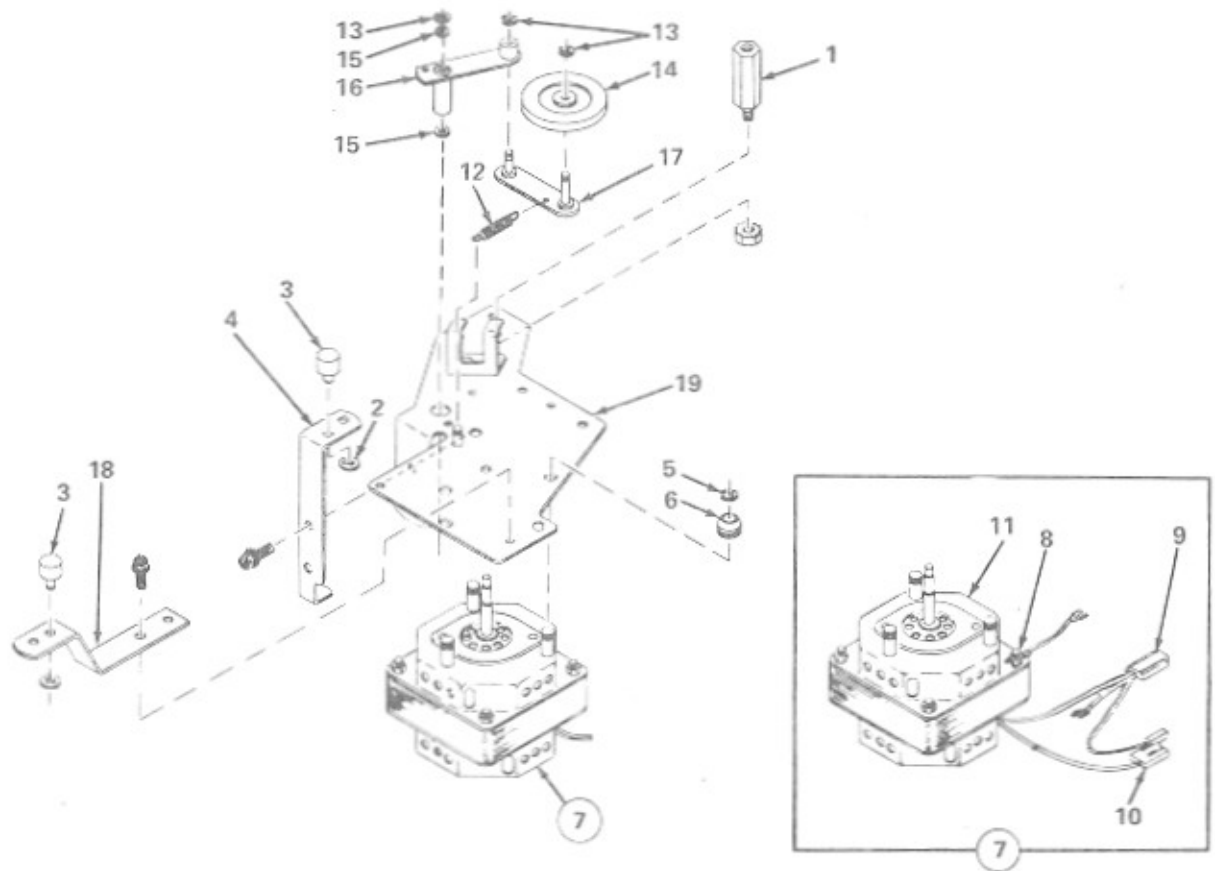

FIG. AND INDEX NO.	ROWE PART NO.	DESCRIPTION	QTY. PER ASSY
11-	404-05074	Turntable Motor and Plate Assembly (Figure 8, Item 15)	REF
1	201-10708	Tone Arm Bearing	1
2	702-01437	Retaining Ring	2
3	200-10897	Gripper Bow Rest	2
4	200-10886	Gripper Bow Rest Bracket (L.H.)	1
5	712-01430	Retaining Ring	3
6	200-11501	Grommet	3
7	302-05240	Turntable Motor Assembly	1
8	216-12300	Wire and Lug Assembly	1
9	302-07490	Universal Connector Cap Housing, 3 Circuit	1
10	201-51106	Triple Receptacle (Insulated)	1
11	302-05193	Turntable Motor	1
12	200-00907	Tension Spring	1
13	701-01430	Retaining Ring	3
14	201-10889	Idler Wheel Assembly	1
15	712-01213	Washer	2
16	201-11610	Link and Bushing Assembly	1
17	201-10888	Link and Pin Assembly	1
18	200-10890	Gripper Bow Rest Bracket (Front)	1
19	302-05189	Turntable Motor Mount Assembly	1

FIGURE 12

Cam Switch and Motor Assembly

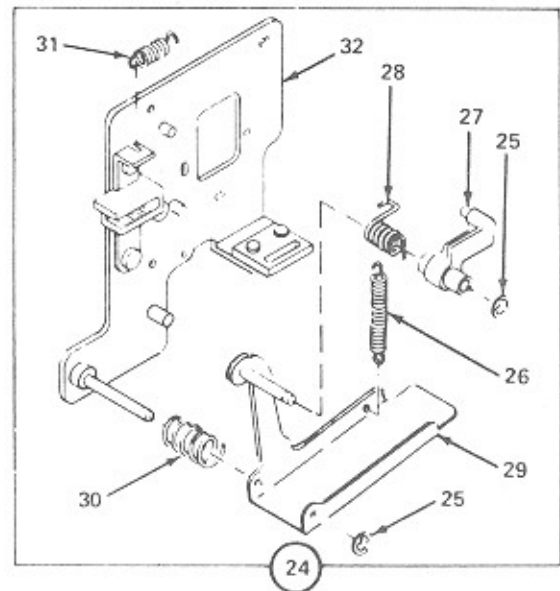
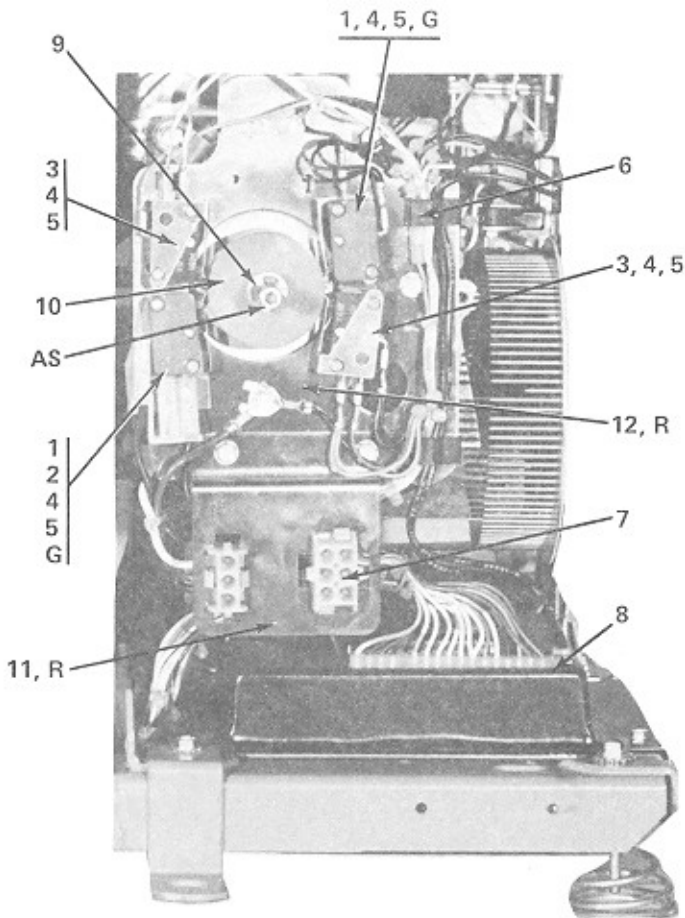
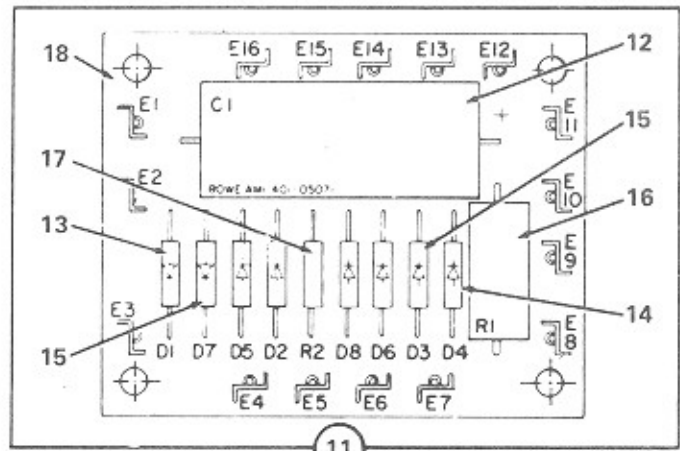
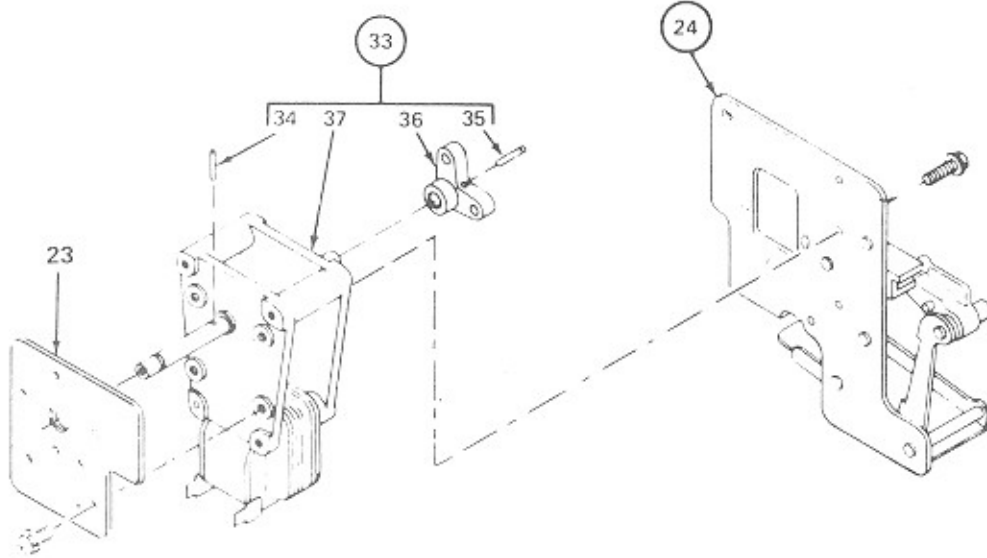

FIG. AND INDEX NO.	ROWE PART NO.	DESCRIPTION	QTY. PER ASSY
12-	401-06906	Cam Switch and Motor Assembly (Figure 8, Item 16)	REF
1	200-10732	. Switch	2
2	200-50548	. Insulator	1
3	200-10731	. Switch	2
4	200-10829	. Switch Actuator	4
5	200-10830	. Twin Nut	4
6	200-07545	. Wire Clip	3
	601-07687	. Mechanism Harness Assembly	1
7	304-07490	. . Universal Connector Cap Housing, 6 Circuit	1
8	718-00755	. . Connector Housing	1
9	704-01430	. Retaining Ring	1
10	300-06636	. Switch Cam	1
11	204-51450	. Housing Mounting Bracket	1
12	300-06628	. Switch Mounting Plate	1
13	300-06627	. Motor Mounting Plate	1
14	303-05129	. Motor Mounting Plate Assembly	1
15	703-01430	. . Retaining Ring	2
16	201-11644	. . Tension Spring	1
17	301-05204	. . Ratchet Pawl Assembly	1
18	200-10835	. . Torsion Spring	1
19	201-10834	. . Actuator Arm Assembly	1
20	200-12075	. . Compression Spring	1
21	200-03816	. . Tension Spring	1
22	203-10833	. . Plate and Ratchet Assembly	1
23	201-11598	. Motor and Crank Assembly	1
24	706-01131	. . Roll Pin	1
25	719-01130	. . Roll Pin	1
26	202-10807	. . Crank and Pin Assembly	1
27	401-05059	. . Transfer Motor Assembly	1

FIGURE
13

Encoder Assembly

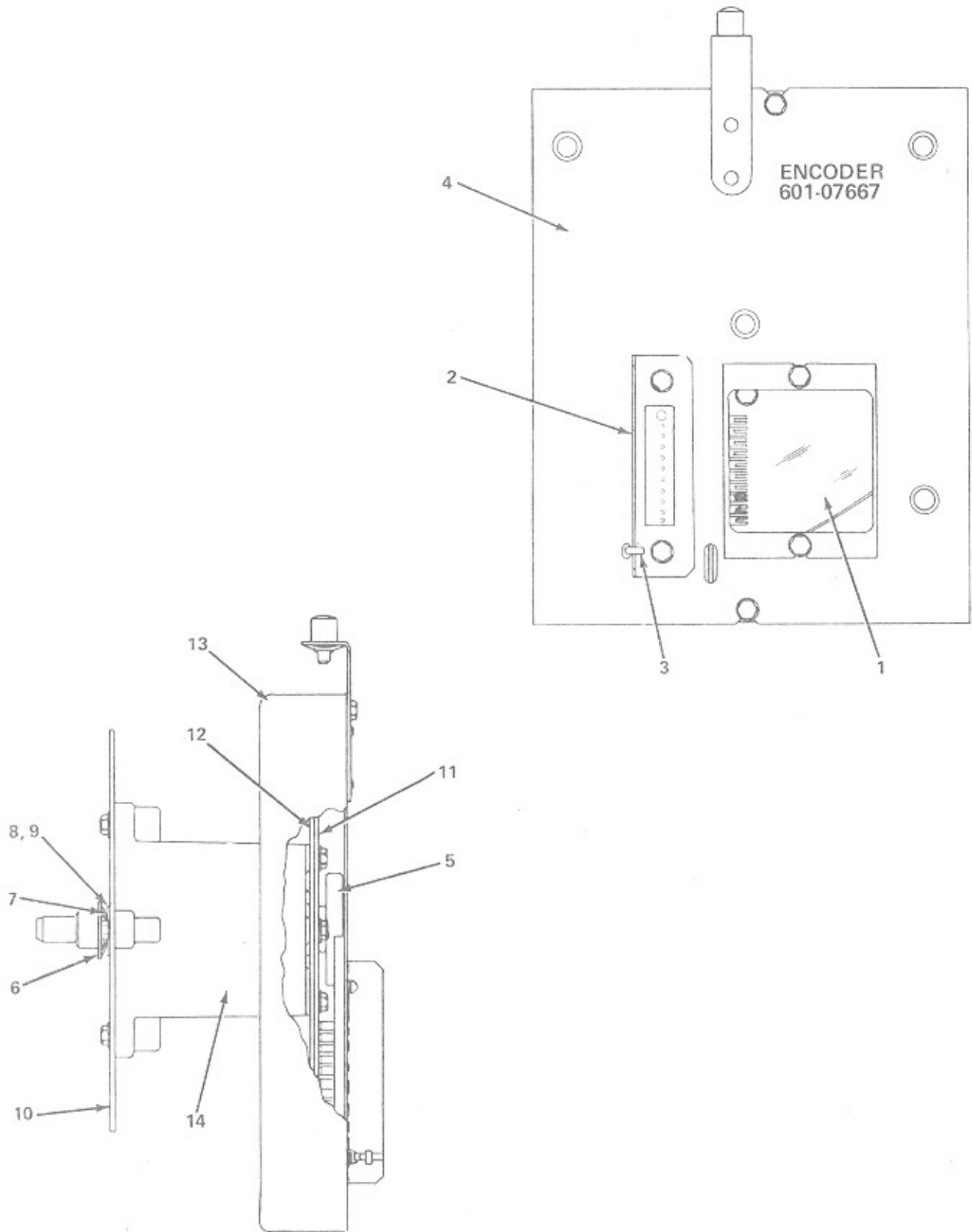

FIG. AND INDEX NO.	ROWE PART NO.	DESCRIPTION	QTY. PER ASSY
13-	601-07667	Encoder Assembly (Figure 8, Item 17)	REF
1	201-17597	. Window	1
2	201-17598	. Cover	1
3	701-08001	. Cable Tie	1
4	401-06879	. Shaft and Base Assembly	1
5	301-07498	. Brush Block Assembly	1
6	706-01430	. Retaining Ring	1
7	741-01225	. Bowed Washer	1
8	710-01209	. Flat Washer	1
9	711-01460	. Bearing	1
10	301-07477	. Selector Gear	1
11	301-07474	. Encoder Wheel	1
12	301-07473	. Disc	1
13	401-06875	. Cover	1
14	301-07610	. Hub Assembly	1

**FIGURE
14**

D.C. Converter

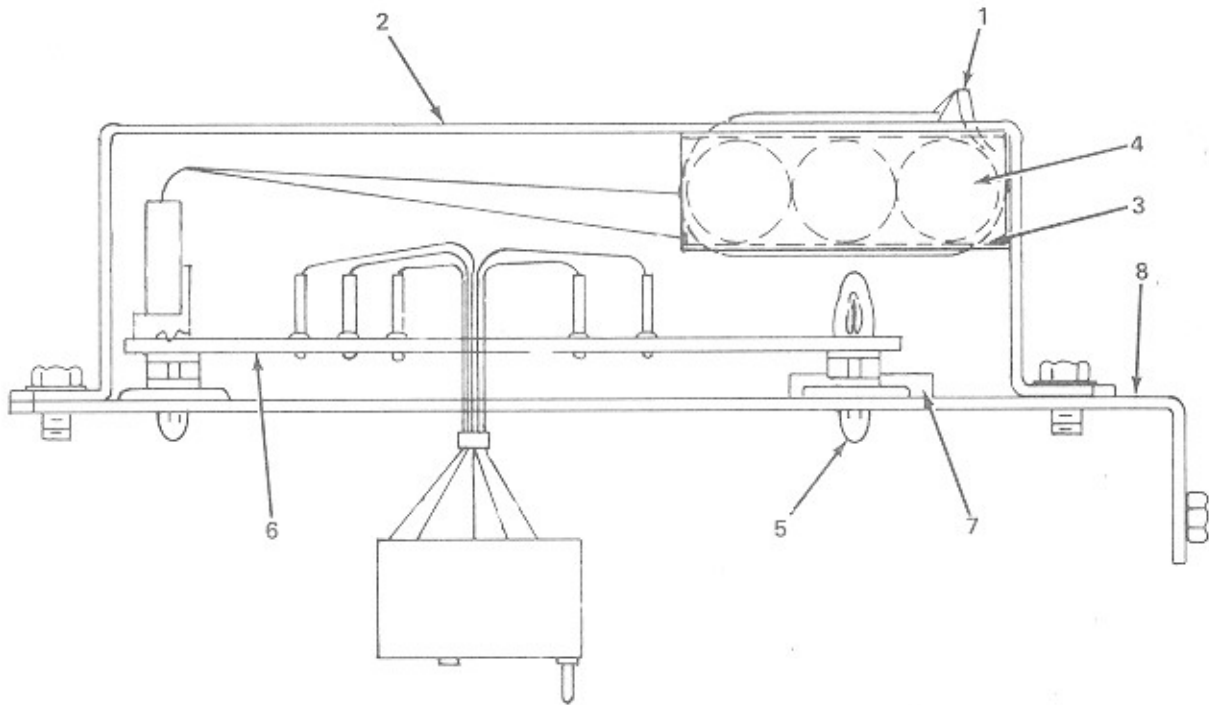

FIG. AND INDEX NO.	ROWE PART NO.	DESCRIPTION	QTY. PER ASSY
14-	301-07541	D.C. Converter (Figure 8, Item 19)	REF
1	706-08001	. Cable Tie	1
2	301-07628	. Converter Board Cover	1
3	201-17747	. Battery Insulator	1
4	201-17740	. Battery Assembly	1
5	702-05000	. Circuit Board Support	3
6	601-08077	. DC to DC Converter Circuit Board Assembly (See schematic in Part 2 for parts list)	1
7	706-02204	. Foamed Tape	1
8	301-07627	. Converter Board Mounting Bracket	1

Sprag Assembly

**FIGURE
15**

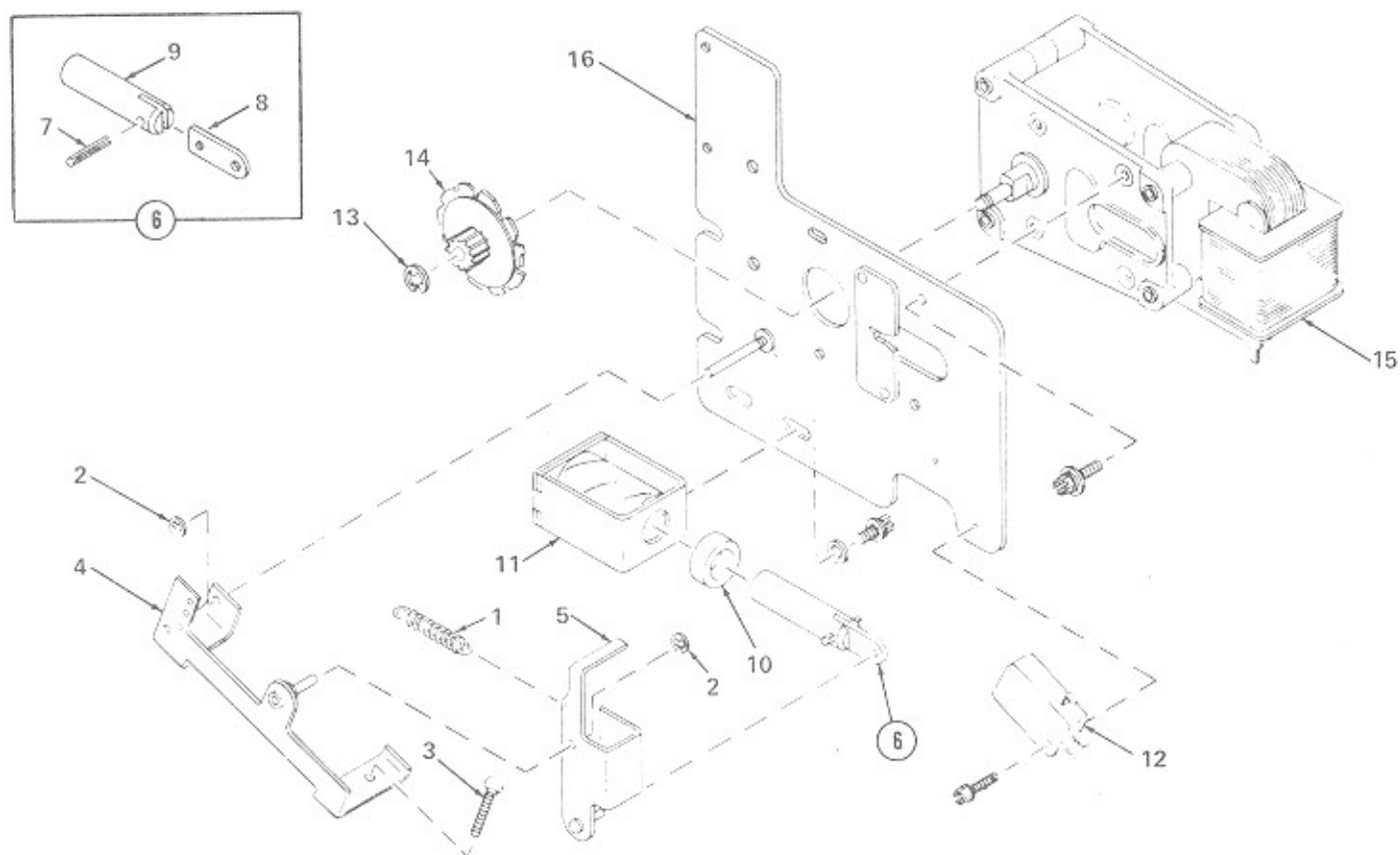

FIG. AND INDEX NO.	ROWE PART NO.	DESCRIPTION	QTY. PER ASSY
15-	405-05022	Sprag Assembly (Figure 8, Item 39)	REF
1	200-10843	. Tension Spring	1
2	705-01430	. Retaining Ring	2
3	200-03822	. Adjusting Screw	1
4	201-10855	. Sprag Link Assembly	1
5	201-10856	. Sprag Lever Assembly	1
6	201-10857	. Plunger Assembly	1
7	703-01130	. Roll Pin	1
8	200-06226	. Plunger Link	1
9	200-10848	. Solenoid Plunger	1
10	200-10849	. Plunger Stop	1
11	206-11505	. Solenoid Assembly	1
12	200-10732	. Switch	1
13	703-01430	. Retaining Ring	1
14	300-05133	. Sprag Wheel	1
15	401-06950	. Magazine Motor	1
16	301-05135	. Sprag Bracket Assembly	1

FIGURE
16

Main Power Supply

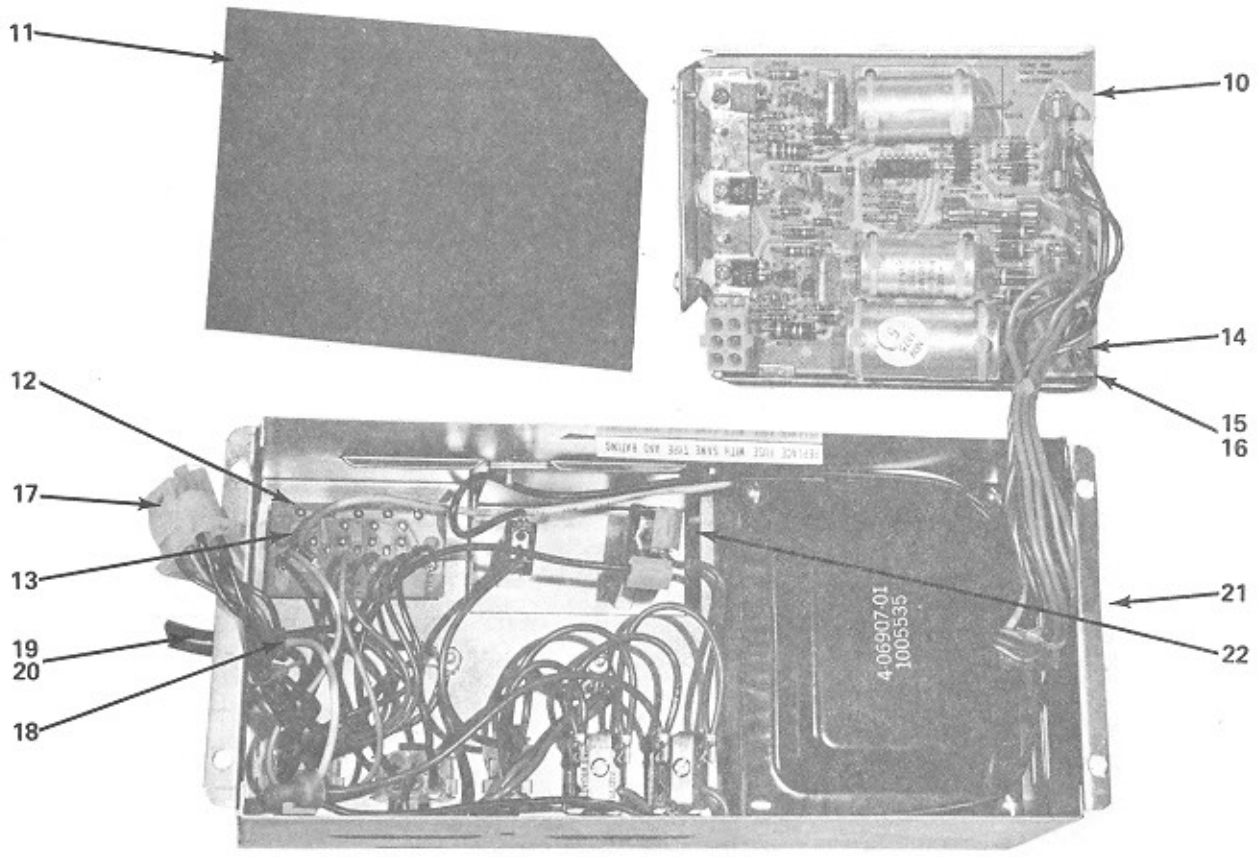
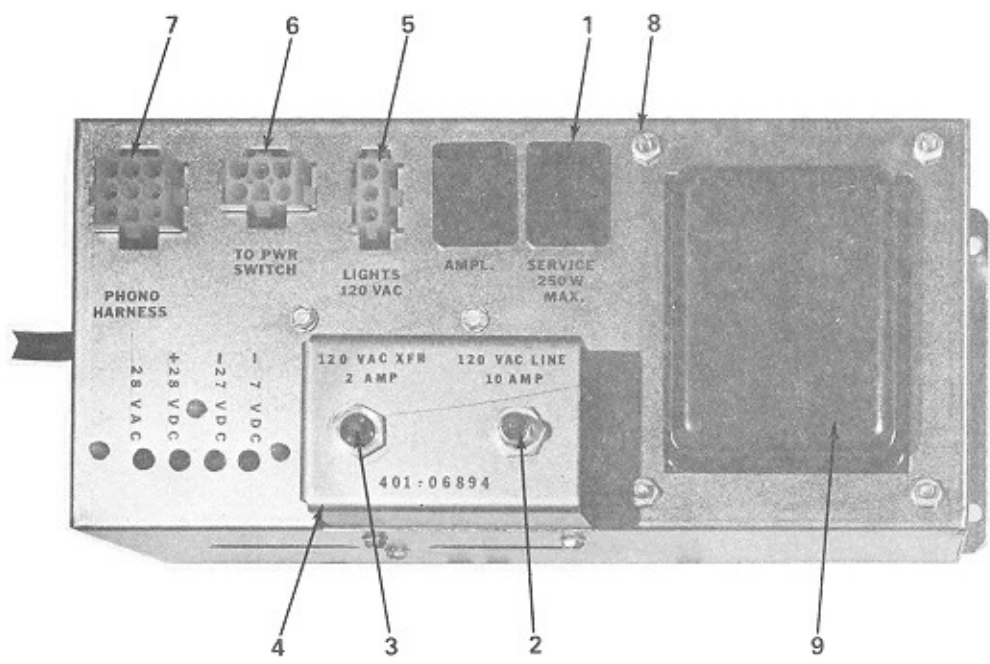

FIG. AND INDEX NO.	ROWE PART NO.	DESCRIPTION	QTY. PER ASSY
16-	401-06894	Main Power Supply (Figure 1, Item 115)	REF
1	200-13759	. 3 Wire Convenience Outlet	2
	301-07548	. Circuit Breaker and Bracket Assembly	1
2	725-00734	. . 10 Amp Circuit Breaker	1
3	715-00733	. . 2 Amp Circuit Breaker	1
4	301-07549	. . Bracket with Lettering	1
5	302-07490	. 3 Circuit Universal Connector Cap Housing	1
6	304-07490	. 6 Circuit Universal Connector Cap Housing	1
7	305-07490	. 9 Circuit Universal Connector Cap Housing	1
8	201-17621	. 8-32 Non-Standard Hex Nut	4
9	401-06907	. Main Power Supply Transformer	1
10	401-06850	. Power Supply Circuit Board (See power supply schematic in Part 2 for parts list)	1
11	201-17676	. Power Supply Insulator	1
12	401-06960	. Voltage Indicator (L.E.D.) Circuit Board (See power supply schematic in Part 2 for parts list)	1
13	704-05000	. Circuit Board Support	3
14	706-05000	. Circuit Board Support	2
15	200-13778	. Molded Bumper	1
16	301-07546	. Support Plate	1
	201-17760	. "U" Type Speed Clip Fastener	1
17	304-07491	. 6 Circuit Universal Connector Plug Housing	1
18	704-02321	. Strain Relief	2
19	201-11212	. Cord and Plug Assembly	1
20	200-14059	. Cord Hole Cover	1
21	401-06908	. Chassis with Lettering	1
22	200-50393	. Insulator	2

**FIGURE
17**

Output Transformer Assembly

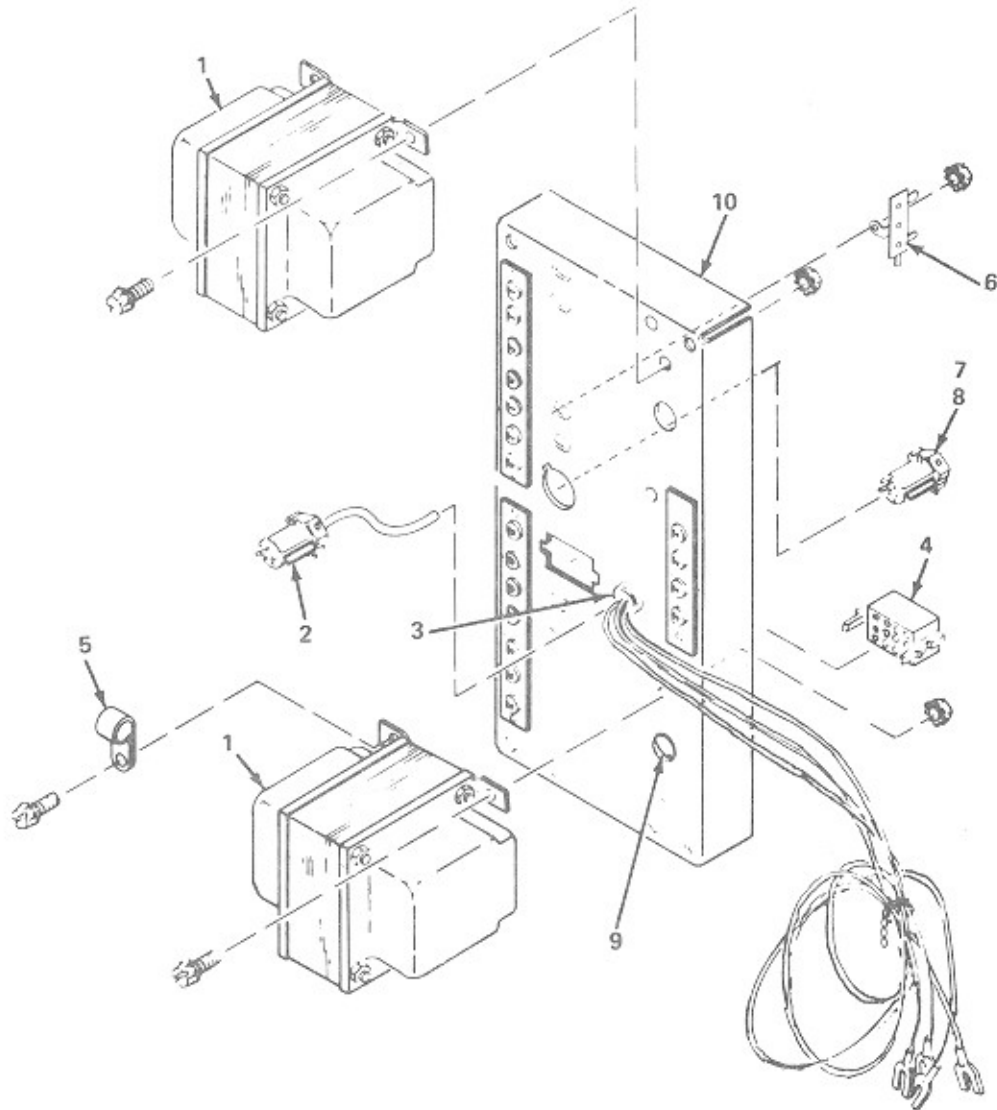

FIG. AND INDEX NO.	ROWE PART NO.	DESCRIPTION	QTY. PER ASSY
17-	404-06322	Output Transformer Assembly (Figure 1, Item 118)	REF
1	401-06522	. Output Transformer	2
	301-06327	. Plug And Cable Assembly	1
2	201-13541	. . 7 Circuit Combo-Line Cap Housing	1
3	701-02331	. Strain Relief	1
	301-07488	. Plug and Cable Assembly	1
4	305-07490	. . 9 Circuit Universal Connector Cap Housing	1
5	704-00931	. Cable Clamp	1
6	314-04225	. Terminal Strip	1
7	201-15373	. Plug and Cable Assembly	1
8	201-13540	. . 7 Circuit Combo-Line Plug Housing	1
9	202-02331	. Strain Relief	2
10	405-05776	. Chassis Assembly with Lettering	1

Shell Assembly

**FIGURE
18**

FIG. AND INDEX NO.	ROWE PART NO.	DESCRIPTION	QTY. PER ASSY
18	601-08250	Shell Assembly (Figure 1, Item 120)	REF
	200-09326	. Teenut	6
	201-15372	. Teenut	2
	204-17506	. Vent Tube	1
	201-17506	. Vent Tube	2
	701-02402	. Wire Mesh Screen	1
	719-02401	. Wire Mesh Screen	1
	300-06257	. Hand Hole Cover	4
	401-06001	. Support Bracket Assembly	1
	200-14518	. Lock Spring	1
	301-06340	. Caster and Cup Assembly	4
	401-07028	. Skid Rail	2
	400-06206	. L.H. Gusset	1
	400-06207	. R.H. Gusset	1