

## SECTION 2 - INSTALLATION

### INTRODUCTION

This section contains instructions for unpacking the phonograph and installing it on location. The phonograph is shipped with all major components in place. Save all tie-down hardware should it become necessary to move the phonograph to another location.

### ACCESSORIES BAG ASSEMBLY

Included is a plastic bag containing slip-on terminals connecting accessories, an assortment of spare fuses and spare contacts for connectors. It is recommended that you leave this Service Manual and the accessory bag assembly in the phonograph cabinet in case they are needed.

### WARRANTY REGISTRATION CARD

A postage-paid warranty registration card is included with the phonograph. Use this card to register the phonograph for in-warranty repairs.

### UNPACKING INSTRUCTIONS

The phonograph is shipped in one carton, ready for installation. The shipping carton should be opened carefully to prevent the phonograph from being damaged or scratched. Inspect the exterior and interior of the cabinet for evidence of damage.

In case of damage, please notify the delivering carrier at once to call and examine the phonograph regardless of the external condition of the boxes. Under U.S. regulations, damage claims must be collected by the consignee. Do not return shipping-damaged merchandise until after your claim has been established. Once your claim is established, damaged merchandise may be returned to the Rowe/AMI distributor for repair. The invoice for repair charges may then be collected from the carrier. Do not destroy packing material or boxes until the carrier's agent has examined them. Unpack the phonograph as follows.

### REMOVE PACKING CASE AND SHIPPING CARTON

1. Carefully open packing case. Do not use shipping hooks or other sharp instruments.
2. Remove plastic bag from phonograph cabinet.

### OPEN PHONOGRAPH CABINET

1. Locate red key bag. Insert key in lock and turn. The top door will unlatch and glide smoothly up to the fully open position.
2. Remove tape from title panel. Pull out rods as shown in figure 1-3 to release title panel. Swing panel down from the top. The panel is not removable.
3. Release latches and open front door as shown.

### REMOVE RECORD CHANGER MECHANISM TIE-DOWN BOLTS

1. Remove shipping bolt from rear of cabinet as shown in figure 1-4
2. Rotate record changer tie-down brackets away from mechanism support frame as shown. Lift up and remove.
3. Remove rubber bands and shipping block from tone arm and toggle shifter plunger.
4. Remove turntable hold-down clip. Replace screw.
5. Remove turntable by pulling turntable straight up. Remove rubber band and shipping block from idler wheel.

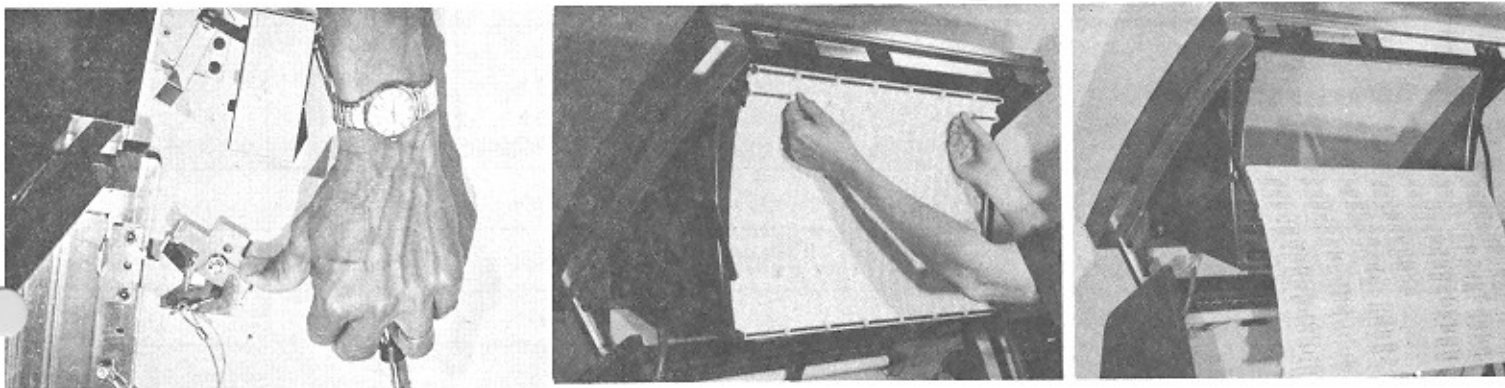

FIGURE 1-3. OPENING PHONOGRAPH CABINET

- Replace turntable, making sure that idler wheel rides on inside of turntable rim. This is accomplished by manually rotating turntable clockwise.
- Remove stylus cover from cartridge and stylus.

8. Save shipping hardware for future use.

9. Remove adhesive tape.

10. Check that all plugs are firmly seated in their respective receptacles

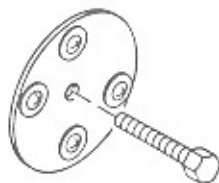
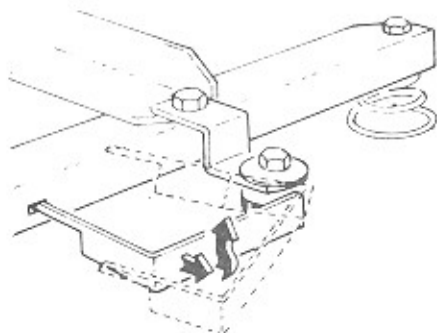

PHONOGRAPH REAR

FIGURE 1-4. REMOVING MECHANISM TIE-DOWN

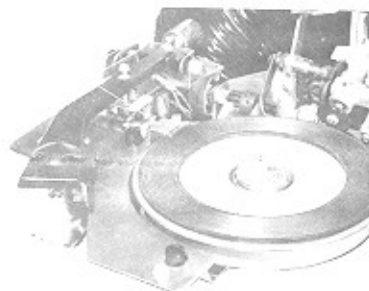

### LEVEL PHONOGRAPH

Level the phonograph cabinet left-to-right and front-to-back to ensure proper slug rejector operation. This is done by placing spacers under the caster wheels.

### INSTALL LICENSE CARD

For locations where a license must be displayed, a license card area has been provided on the title rack. To install license card, follow this procedure:

- Open top door and swing down title panel.
- The license card frame has tabs, top and bottom, which lock into two corresponding slots in the title panel. Pull the frame outward at the sides to free it.
- Trim the license card to fit and install it from the back of the frame.
- When the frame is put back, bend it slightly as shown to engage tabs in slots.



FIGURE 1-5. LICENSE CARD INSTALLATION

TABLE 1-3. USE OF AMPLIFIER CONTROLS FOR ACOUSTICAL COMPENSATION

SOUND LEVEL IN ROOM	ROOM ACOUSTICS					
	DEAD OR SOFT HIGHLY ABSORBENT		AVERAGE - MODERATELY ABSORBENT		LIVE OR HARD NON-ABSORBENT	
	SET BASS BOOST CONTROL	SET TREBLE RANGE CONTROL	SET BASS BOOST CONTROL	SET TREBLE RANGE CONTROL	SET BASS BOOST CONTROL	SET TREBLE RANGE CONTROL
LOUD	LOW	MOD/MAX	LOW	MOD/MAX	MOD	LIM
MODERATE	LOW	MAX	MOD	MOD/MAX	MAX	LIM
SOFT	MOD	MAX	MAX	MAX	MAX	MOD

NOTE: Reduce Treble Range setting as required by record noise (scratch) conditions.

## AMPLIFIER SET-UP

### ACOUSTICAL COMPENSATION (BASS AND TREBLE CONTROLS)

The pre-amplifier contains treble range and bass boost controls to compensate for room acoustics in various locations. These controls are on the amplifier chassis. The sound level at which the phonograph will be operated and the room furnishings determine the settings of these controls. A room with carpeting and drapery is a soft or highly-absorbent location. A crowded room is also highly-absorbent. These locations require higher sound levels. A room with paneled walls and a bare or tiled floor is a hard non-absorbent location. Bass boost and treble range control settings are listed in the above table. Note that more bass boost is required at low volume levels. The amplifier incorporates circuitry that provides extra bass compensation at low volume levels.

### STEREO BALANCE

The stereo balance control is provided to equalize left and right channel amplifier output. This control affects only

the side speakers; the low-frequency speakers are not affected. This control is factory-adjusted for best performance. If adjustment is required, play a monaural selection and adjust the control for equal sound from each side speaker. When balanced, the sound will seem to come from the center of the phonograph.

### AMPLIFIER OPERATION WITH HIGH LINE VOLTAGE

In locations where input line voltage to the phonograph exceeds 125 volts, use the black/red primary lead of the amplifier power transformer instead of the black/yellow lead. This results in a 10% reduction in secondary voltage.

### AUTO PLAY

Set auto play selector switch to 20 min. or 40 min. position. If no auto play is required, set to off position.

### AMPLIFIER OPERATION WITH FM, BACKGROUND MUSIC, PAGING & QUAD

This is an optional add on accessory. See accessory equipment section for explanation of amplifier accessory kit.