

CD-100C

LaserStar® II *Compact Disc* *Phonograph*

Field Service Manual
And Parts Catalog

Volume 2

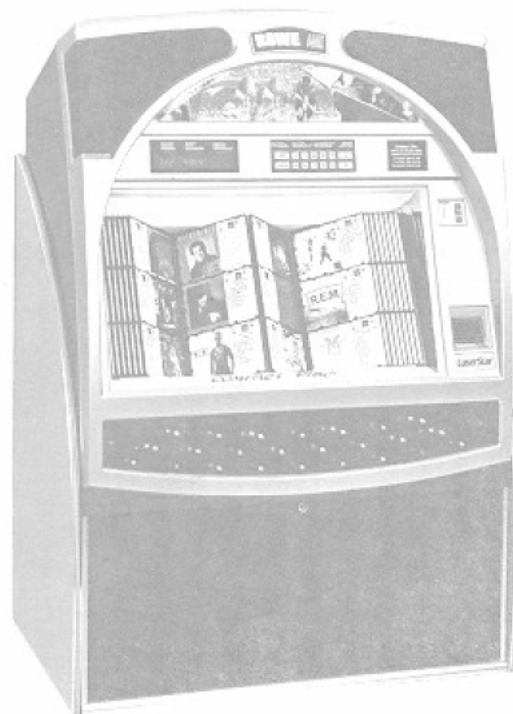

ROWE

ROWE INTERNATIONAL, INC.
1500 UNION AVE, SE • GRAND RAPIDS, MI 49507-1884
(616) 243-3633

Printed in USA

Part No. 21822621
Second Edition
First Printing July 1992

This page intentionally left blank

Table of Contents

SECTION 4 — CBA-2 MAINTENANCE

System Description	4-1
Equipment Description	4-1
Transport	4-1
Logic Board	4-1
Bill Acceptor Transport/Stacker	4-1
Magnetic Head	4-1
Anti Cheat Lever and V ₄ Sensor	4-2
Transport/Stacker Drive	4-2
Bill Acceptor Logic Board	4-2
Power and Status LED's	4-2
Reset Pushbutton	4-2
Functional Description	4-2
Power Up Sequence	4-2
Acceptor in Standby Mode (Ready to Accept Bills)	4-3
Problems that may Arise in Standby Mode	4-3
Actions Taken	4-3
Bill Acceptance Mode	4-4
Routine Maintenance	4-11
Tools Required	4-11
Removing Jammed Bills from Bill Acceptor	4-11
Bill Jamming Checklist	4-12
Cleaning	4-12
Lubrication	4-12
Mechanical Adjustments	4-13
Belt Adjustment	4-13
Gear Backlash Adjustment	4-14
Stacker Home Switch Adjustment	4-15
Magnetic Head Alignment	4-15
Removal and Replacement Procedures	4-15
Removing Inlet	4-15
Removing Watershield	4-16
Re-installing the Watershield	4-16
Removing the Lower Harness and Cell Assembly	4-16
Re-installing the Lower Harness and Cell Assembly	4-17
Trouble Shooting Aids	4-19

SECTION 5 — TROUBLE SHOOTING

Introduction	5-1
Trouble Shooting Aids	5-1
Replacing the CCC Eprom	5-2
Free Play	5-2

Table of Contents

SECTION 5 — TROUBLE SHOOTING *(Continued)*

CD Module Functions	5-2
Digital Display Module	5-2
CCC	5-2
Mechanism Control	5-3
CBA-2 Logic Board	5-3
Sequence of Operation	5-3
CCC	5-4
Mechanism Control	5-4
CBA-2	5-4
Digital Display	5-4
Status Lamps	5-10
Main Power Supply LED's	5-10
Mechanism Control and CD Decoder	5-10
Central Control Computer	5-11
Digital Display	5-11
CBA-2	5-11
Errors and Warnings	5-12
Basic Concepts	5-12
Errors (ERR)	5-12
Warnings (WARN)	5-12
Viewing the Errors and Warnings	5-12
Error and Warning Summary	5-15
Description of Errors/Warnings and Probable Causes	5-16
Clearing Errors/Warnings from Memory	5-21
Disc Conditions	5-22
Basic Concepts	5-22
Programmable Disc Condition Logging	5-22
Skip Log (Service Code 35)	5-22
Skip Cancel (Service Code 36)	5-22
Time Cancel (Service Code 37)	5-22
Factory Settings	5-22
Non-Programmable Disc Condition Logging	5-22
Logged Track Number equals 00	5-22
Logged CANCL and SKIP Equals 99	5-23
Logged CANCL equals 99 and SKIP equals 77	5-23
Logged CANCL equals 99 and SKIP equals 88	5-23
Viewing Disc Conditions	5-23
Clearing Disc Conditions from Memory	5-26
Trouble Shooting	5-27
Sound System Quick Checks	5-38
No Sound - Both Channels	5-38
No Sound, Low Sound or Distorted Sound Right or Left Channel Only	5-38
Constant High Volume - Can Not Adjust	5-40
Excessive Hum	5-40

Table of Contents

SECTION 5 — TROUBLE SHOOTING *(Continued)*

Component Lists

Main Power Supply	5-48
Preamplifier Board	5-54
Amplifier Driver Board	5-64
Crossover Network	5-67
Display Assembly	5-72
Central Control Computer	5-82
Mechanism Control Board	5-98
Title Rack Interface Board	5-107

SECTION 6 — MECHANICAL ADJUSTMENTS

Lubrication	6-1
-------------------	-----

Unscheduled Maintenance	6-1
-------------------------------	-----

Mechanism Maintenance And Adjustments	6-1
---	-----

CD Player Mechanism	6-1
Cleaning the Laser Lens	6-2
CD Player Maintenance	6-2
Removing the Mechanism Control Unit	6-2
Removing the CD Player	6-4
Hold Down Assembly and Hold Down Plate Height	6-6
Service Check	6-6
Adjustment	6-6
Hold Down Plate Centering	6-6
Optical Switch Adjustment	6-7
Sprag Assembly	6-8
Adjustments	6-8
Sprag Assembly Removal	6-9
Disc Magazine and Support	6-10
Adjustments	6-10
Magazine Belt Adjustment	6-10
Cam Switch	6-11
Adjustments	6-11
Cam Switch Check and Adjustment	6-11
Title Rack Switch Adjustment	6-14

SECTION 7 — MISCELLANEOUS

CD-100C Specifications	7-1
General	7-1
Power Requirements	7-1
Credit and Pricing System	7-1
Sound System	7-2
Door Lighting	7-2

Fuses and Circuit Breakers	7-3
----------------------------------	-----

Resistor Code Chart	7-5
---------------------------	-----

Table of Contents

SECTION 8 — PARTS CATALOG

CD-100C Code Sheet	8-2
Introduction	8-3
Catalog Description	8-3
Parts List Description	8-3
Ordering Replacement Parts	8-3
Parts Catalog	8-4
Accessory Equipment	8-50

FREQUENTLY USED FIGURES AND TABLES for VOLUME 2

Accessory Equipment (<i>Table 8-1</i>)	8-50
Block Diagram, CD100C (<i>Figure 5-1</i>)	5-9
Central Control Computer	
I/O Matrix (<i>Table 5-3</i>)	5-86
Schematic (<i>Figure 5-12A</i>)	5-74
Crossover Network (<i>Figure 5-8C</i>)	5-66
Display Assembly Schematic (<i>Figure 5-11</i>)	5-71
Harness Diagram, System (<i>Figure 5-4</i>)	5-43
Main Power Supply	
Wiring Diagram (<i>Figure 5-5A</i>)	5-44
Schematic - Domestic (<i>Figure 5-5B</i>)	5-45
Schematic - Export (<i>Figure 5-6B</i>)	5-47
Wiring Diagram (<i>Figure 5-6A</i>)	5-46
Mechanism Control	
Block Diagram (<i>Figure 5-13A</i>)	5-89
Schematic (<i>Figure 5-13B</i>)	5-91
CBA-2 Schematic (<i>Figure 4-3</i>)	4-9
Amplifier Schematic (<i>Figure 5-8A</i>)	5-63
Preamplifier Schematic (<i>Figure 5-7A</i>)	5-51
Resistor Color Code (<i>Figure 7-2</i>)	7-5
Transformer	
Output Voltages (<i>Figure 5-9</i>)	5-68
Wiring Diagram (<i>Figure 5-10</i>)	5-69
Trouble Shooting Chart	
Modular (<i>Table 5-2</i>)	5-28
CBA-2 (<i>Table 4-2</i>)	4-20

This page intentionally left blank

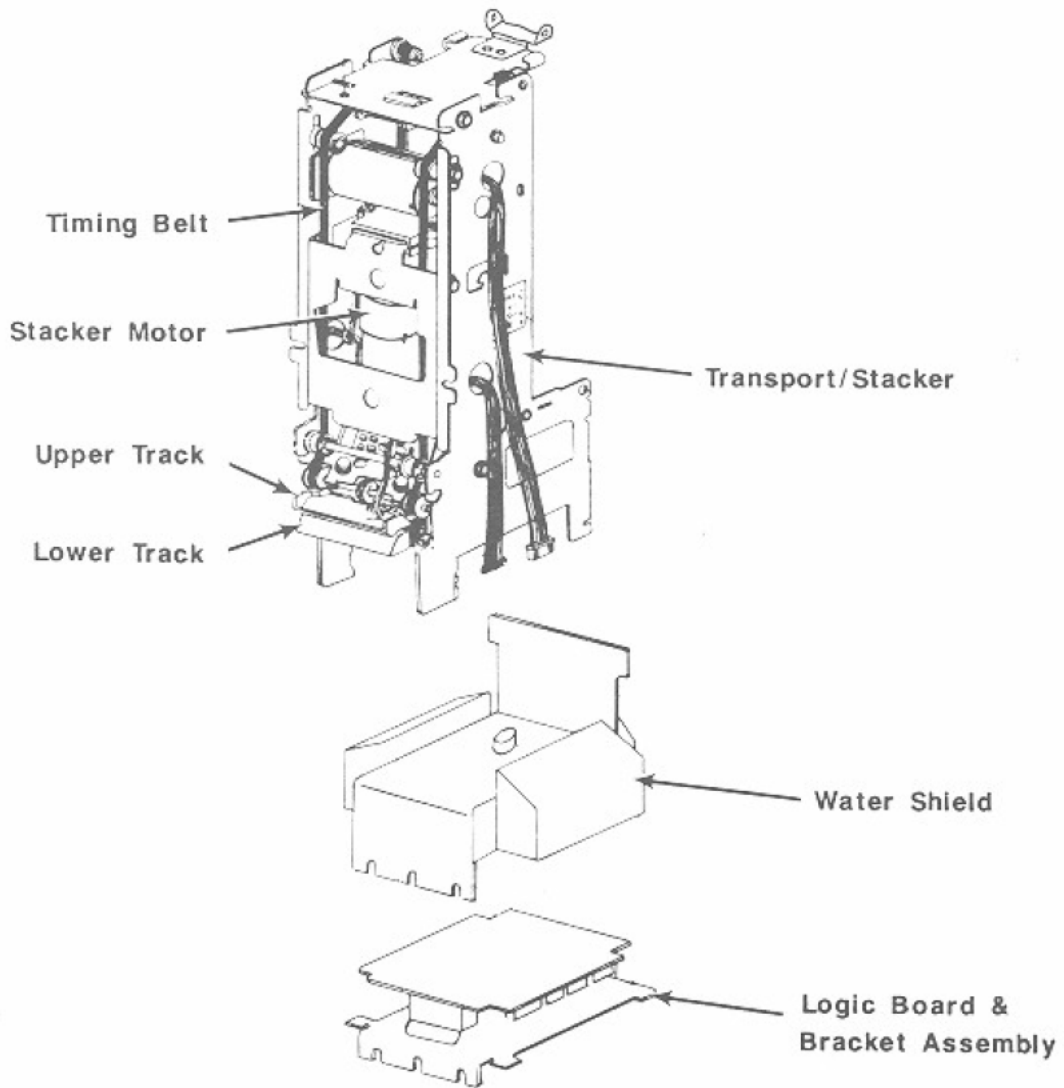

Figure 4-1 CBA-2 Components

Section 4: CBA-2 Maintenance

SYSTEM DESCRIPTION

The Rowe Compact Bill Acceptor-2 (CBA-2) extends the capability of your equipment to include the acceptance of one and five dollar bills. Valid bills of genuine United States currency are accepted by the CBA-2, which then outputs credit pulses. Rejected bills are returned to the customer.

Equipment Description

The CBA-2 consists of a bill acceptor transport/stacker mechanism, an electronic logic board, and a power supply integrated into a single unit.

TRANSPORT

The bill acceptor transport mechanism contains optical and magnetic sensors for bill validation. These sensors transmit their signals to the control circuitry.

The transport/stacker unit uses long life optical cells and a timing belt drive for long trouble-free performance.

LOGIC BOARD

The logic board contains electronics for operation of the CBA-2. Microcomputer based electronic circuitry that provides protection against bogus bills and bills of different denominations. The control of the transport motor, the stacker motor, and the credit function are also contained in the logic board.

BILL ACCEPTOR TRANSPORT/STACKER

The CBA-2 Transport is a mechanical device that carries the bill through five test stations. The transport contains a V_1 , V_2 , V_3 , and V_4 sensor and a magnetic head.

The V_1 sensor consists of an infrared emitter and receiver which senses that a bill has been inserted into the transport.

The V_2 backside sensor consists of a green emitter and receiver to make checks on the backside of the bill.

The V_3 sensor consists of a detector, which senses that the bill has reached the magnetic head.

V_4 verifies that the bill has left the transport.

MAGNETIC HEAD AND BILL PRESSURE ROLLER

The magnetic head checks the magnetic properties of the bill. A spring-loaded pressure roller, located under the lower track, presses the bill firmly against the magnetic head.

ANTI-CHEAT LEVER AND V₄ SENSOR

The anti-cheat lever prevents the bill from being pulled back through the transport once it has exited the transport and credit has been given. The anti-cheat lever also works in conjunction with the V₄ sensor to sense bill position and to provide a signal to give credit when the bill has exited the transport. The V₄ sensor is an infrared emitter/receiver.

TRANSPORT/STACKER DRIVE

The transport uses a direct gear drive from the motor to the drive shaft. The drive shaft drives the front belts, which are also timing belts. Adjustable idler pulleys are used to maintain the correct timing belt tension. The rear belts are the semi-stretch type and do not require length adjustment. The bill is trapped between the front and rear belts for positive, non-slip movement through the transport.

The stacker uses a gear-head motor. A cam on the motor shaft causes the bill pusher plate to move forward and backward inside the transport. This action will remove the bill from between the belts and place it into the bill box. A microswitch riding on the motor cam allows the logic board to monitor the pusher plate position.

Bill Acceptor Logic Board

The logic board directs all of the operations of the bill acceptor. It contains a microcomputer which is the "brain" of the system as well as self-diagnostic circuitry and the interface and drive circuitry necessary to monitor and control the transport/stacker.

Power is provided by the power supply. The CBA-2 requires a voltage of +12 VDC. A regulator on the logic board reduces the +12 VDC to +5 VDC.

The logic board contains all the electrical controls and visual indicators for the CBA-2. These are:

POWER AND STATUS LED'S

The logic board contains a self diagnostic feature, which is capable of detecting various malfunctions as well as certain normal conditions within the bill acceptor. The POWER LED indicates that the CBA-2 is receiving power. The STATUS LED indicates the status of the CBA-2.

RESET PUSHBUTTON

When the CBA-2 is in a FAULT condition, this pushbutton will cause the CBA-2 to reset.

FUNCTIONAL DESCRIPTION

The following functional description will give you a basic understanding of how the bill acceptor normally operates. This information and the schematic in *figures 4-2 and 4-3* can also be used as an aid in troubleshooting.

Power-Up Sequence

The CBA-2 goes through a well defined power-up sequence as follows:

1. The transport motor runs forward for about 75 milliseconds.
2. The stacker is cycled to purge any bills from the drive belts.
3. The transport motor runs in reverse and the computer adjusts the motor to the correct speed.

If any of the sensors detect a bill during power-up, the reject sequence described later in this section is initiated. If this sequence successfully removes the bill (or object), the power-up sequence just described is followed.

If the stacker does not cycle properly during the power-up sequence, the bill acceptor enters the shutdown sequence (which is described later).

If the transport motor speed cannot be correctly adjusted within 5 seconds, a modified shutdown sequence is followed:

1. The bill acceptor ignores any inserted bills and the STATUS LED flashes in a 7-flash sequence.
2. During each 2-minute interval (up to 8½ hours maximum) the computer will attempt to adjust the motor speed correctly. If the correct speed is attained, the unit will enter the standby mode. If, after 8½ hours, the speed still cannot be set correctly, the bill acceptor will remain in shutdown mode with the STATUS LED in a 7-flash sequence.

Acceptor In Standby Mode (Ready To Accept Bills)

Although the CBA-2 appears to be idle, it is continually checking the sensors in the bill transport and bill stacker mechanisms. If the CBA-2 senses an incorrect signal, it takes the appropriate action.

Problems That May Arise In The Standby Mode:

THE V₃ OR V₄ SENSOR IS ACTIVE

The bill acceptor assumes that something is trapped in the bill transport path if either of these sensors are active while in the STANDBY mode. The bill acceptor then begins the REJECT sequence to remove the trapped object from the path. For further information, see the following paragraphs on the REJECT sequence.

STACKER HOME SWITCH NOT ACTIVATED

The bill acceptor turns on the stacker motor and attempts to return the stacker platen to its HOME position. If it is successful, the bill acceptor returns to the STANDBY mode. If the bill acceptor is unsuccessful, it shuts itself down. For further information, see the following section on the SHUTDOWN sequence:

Actions Taken By The Bill Acceptor To Correct Problems

REJECT SEQUENCE

In order to clear the bill transport mechanism and purge any objects from the transport path, the bill acceptor turns on its motor in the reverse direction. If the bill acceptor is following a normal bill rejection sequence, it will reject the bill and the transport mechanism will return the bill to the bill acceptor opening. The bill acceptor will place the bill so that the bill can be easily grasped by the customer. If the customer retrieves the bill within five seconds, and all other sensors indicate that the transport path is clear, the bill acceptor returns to the STANDBY mode. If the track is not clear, the bill acceptor begins the SELF-CLEARING sequence described in the following paragraph:

SELF-CLEARING SEQUENCE

If the transport cannot clear the transport path as previously described, the bill acceptor begins a SELF-CLEARING sequence. This process consists of a series of reverse cycles to dislodge any object trapped in the transport. If this procedure is successful, the bill acceptor returns to the STANDBY mode. If the track is not clear after 10 cycles, the unit shuts down. The SHUTDOWN sequence is as follows:

SHUTDOWN SEQUENCE

Several things may cause a bill acceptor shutdown. During the SELF-CLEARING sequence, if the bill acceptor is unable to clear an object lodged in the transport path, it will initiate a SHUTDOWN sequence. In the event of a shutdown, the bill acceptor turns everything OFF except the STATUS LED, which it flashes ON and OFF to indicate a FAULT condition. After a fault has occurred, the system must be reset by pushing the RESET button on the logic board.

Bill Acceptance Mode

1. The Customer Inserts A Bill And Bill Validation Begins

- a. The V_1 sensor is covered by leading edge of the bill.
- b. The computer starts the Motor Forward and Motor On circuits, which start transport motor in the forward direction.
- c. As the bill is moved through the transport mechanism, the computer closely monitors all sensors for the proper signals and timings representative of a valid bill.
- d. If the bill meets all of the necessary requirements, the transport motor continues to run until the bill exits the rear of the transport and allows the anti-cheat lever to move back to its rest position, which uncovers the V_4 sensor.

2. Bill Validation Sequence Complete-The Credit And Stacking Cycles Are Activated

- a. The Transport motor continues to run until the bill is in position to be stacked.
- b. The computer sends a credit signal to the output circuitry.
- c. The computer also turns on the bill stacker motor for one cycle of the bill pusher plate, which will move the bill from the transport belts to the bill box.

3. If Any Of The Validation Conditions Are Not Met, The Bill Is Returned To The Customer As Follows:

- a. The transport motor changes direction from forward to reverse and returns the bill to the transport opening.
- b. The computer checks for the V_4 and V_3 sensors to be uncovered by the returning bill.
- c. The computer stops the transport motor with the leading edge of the bill still in the transport inlet covering the V_1 cell.
- d. If the V_1 cell is still covered after 5 seconds, the computer enters the self-clearing sequence as described in *Self-Clearing Sequence* in this section.

This page intentionally left blank.

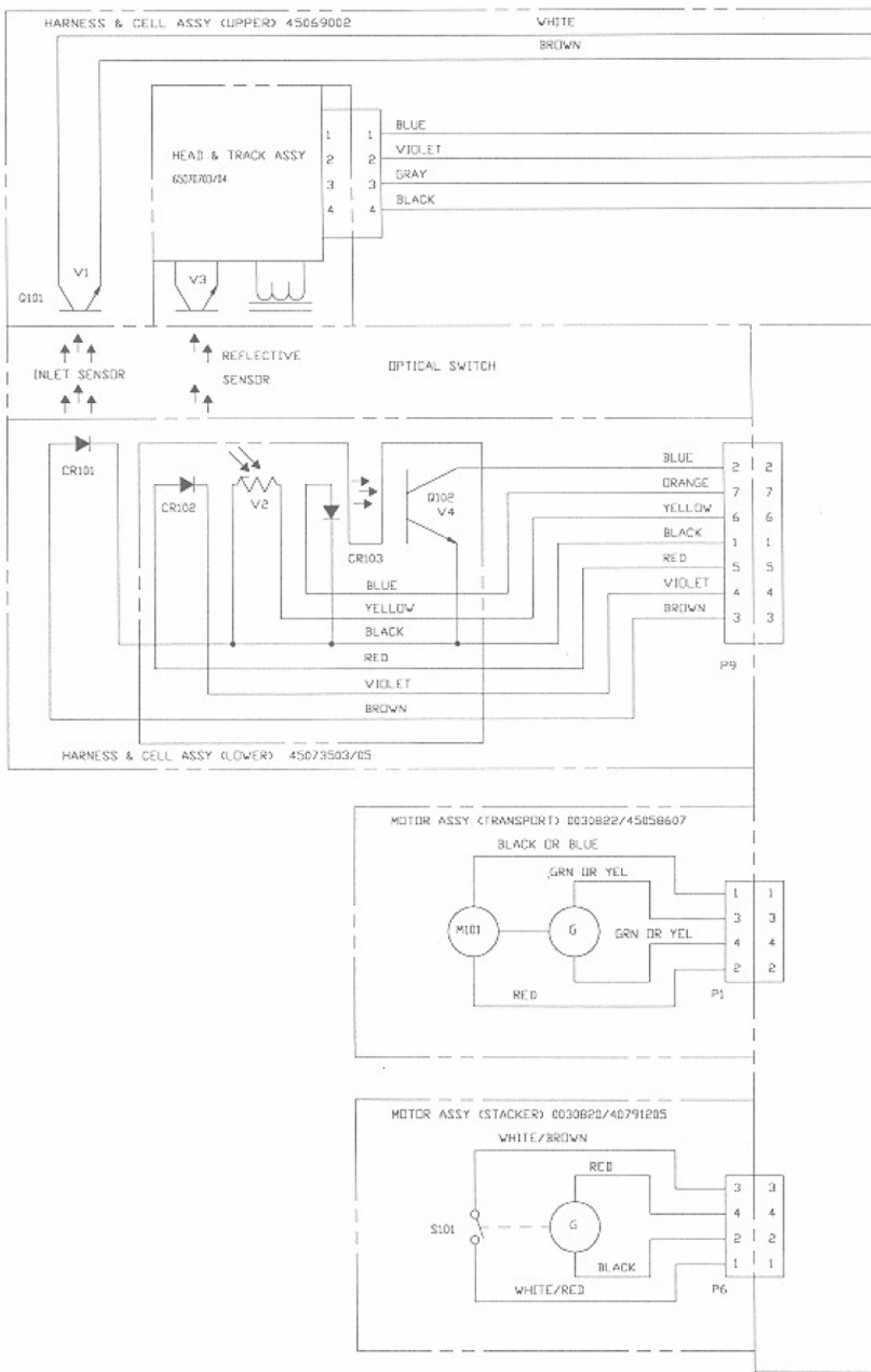

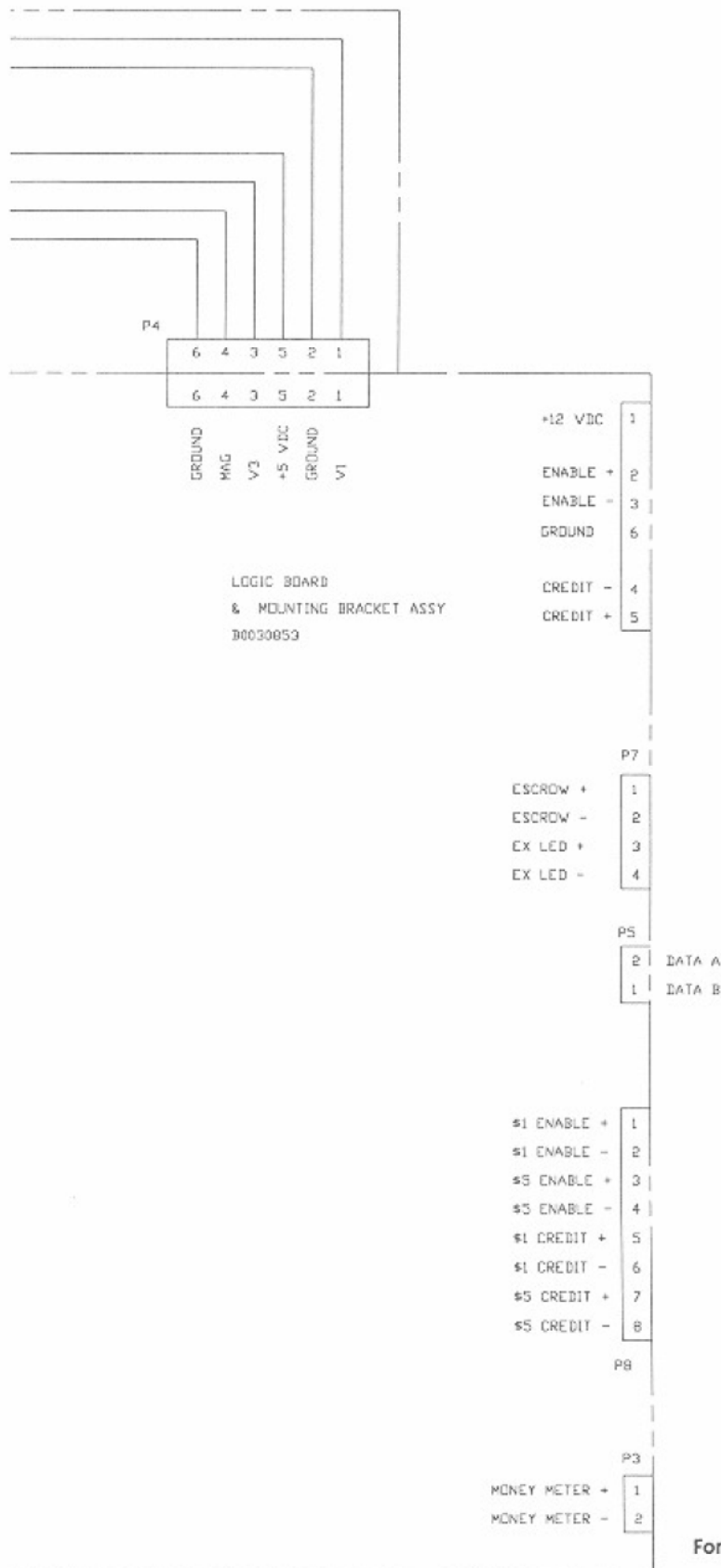

For Equivalent Engineering Drawing See 65093004-Q7 - B
 Figure 4-2. System Block Diagram

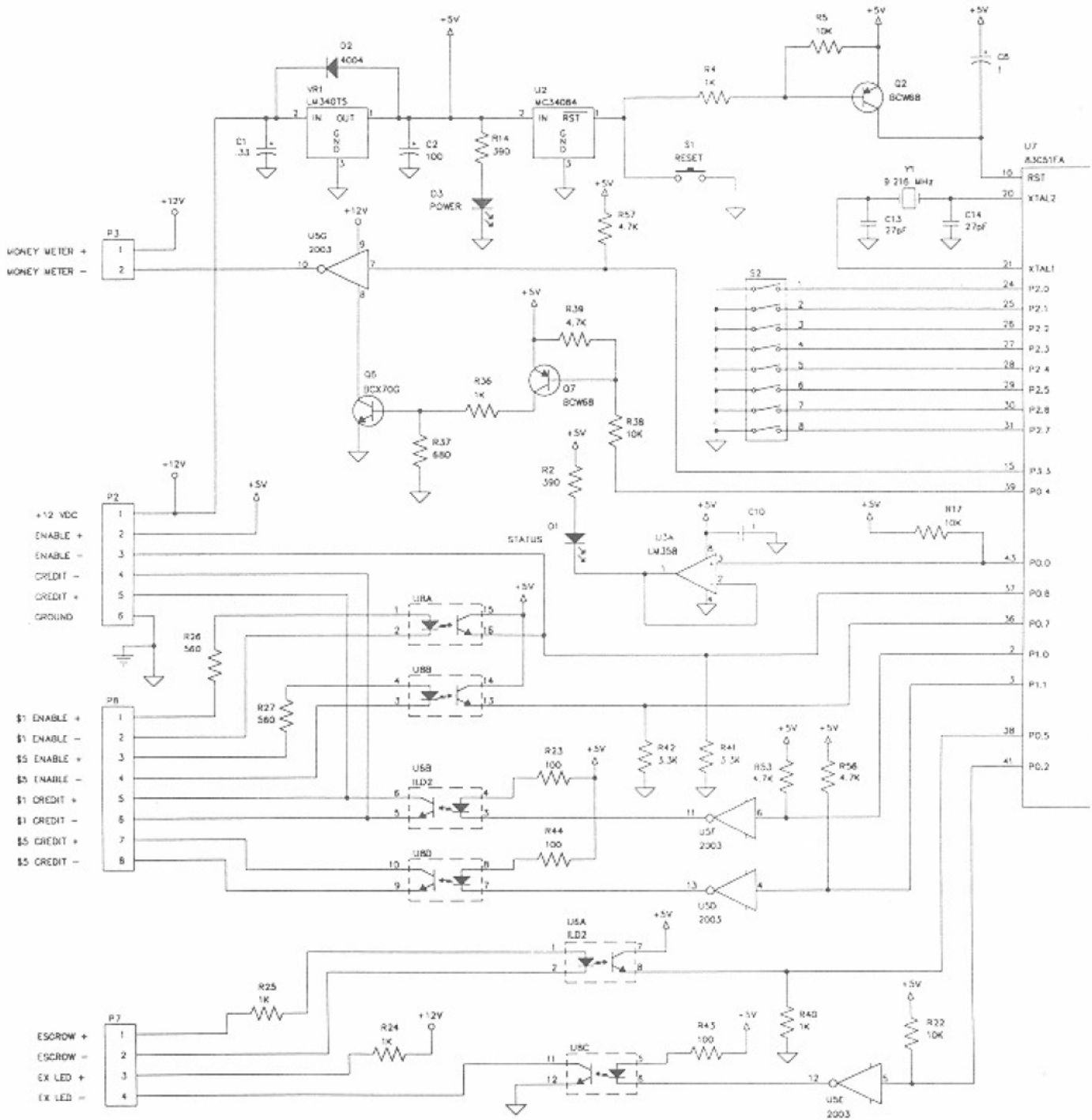

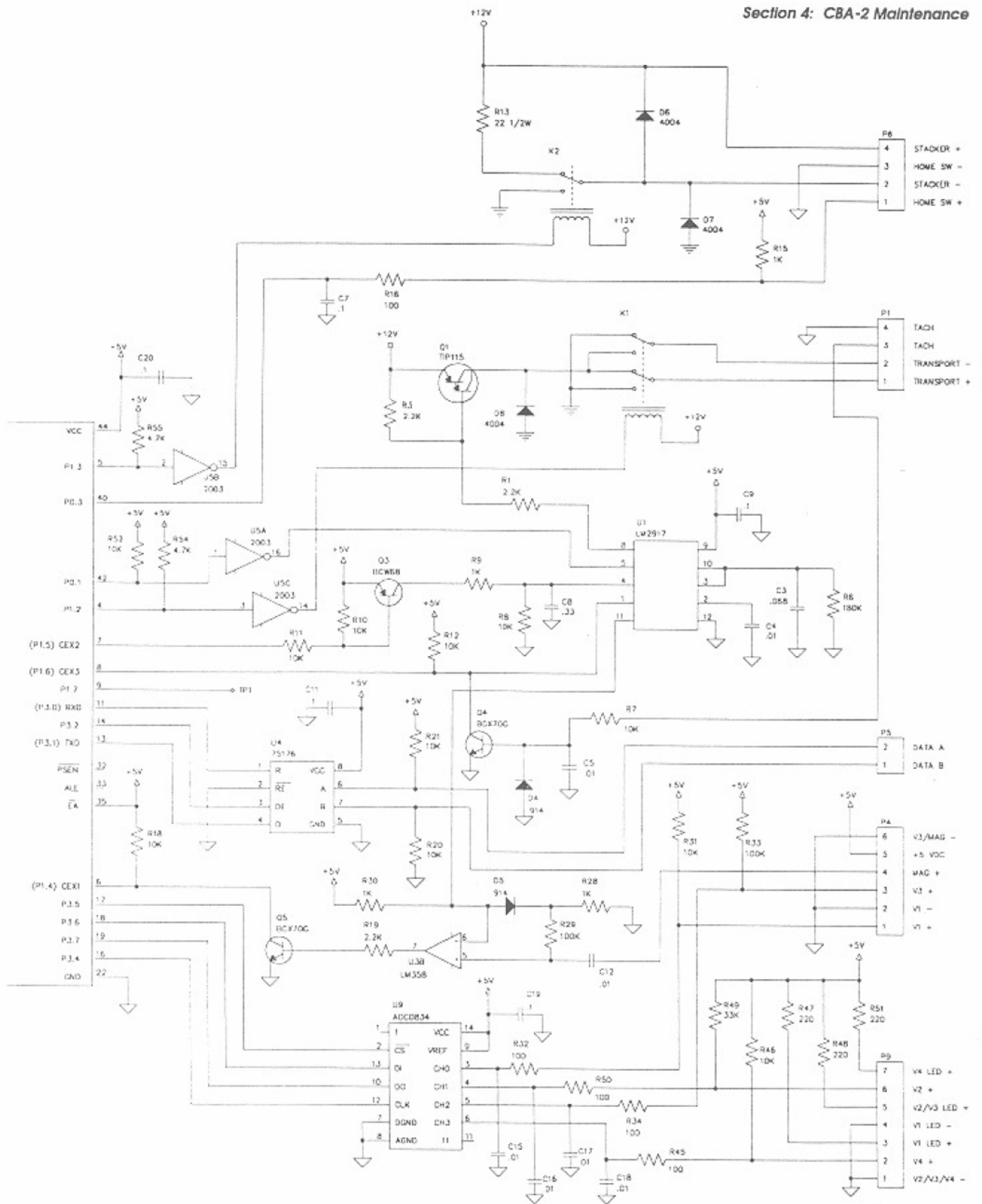

For Equivalent Engineering Drawing See 0030832/53
 Figure 4-3. CBA-2 Schematic Diagram

This page intentionally left blank.

ROUTINE MAINTENANCE

Jammed bills are the cause of most maintenance calls. If you have recurring bill jams or other CBA-2 problems, follow the troubleshooting procedures (see *Trouble Shooting* at the end of this section).

Tools Required

The CBA-2 does not require special tools. The following tools are recommended, however:

Table 4-1. Tools Recommended To Service The CBA-2

1/8" Nut Driver 1/4" Nut Driver 5/16" Nut Driver Small Phillips Screwdriver 3/32" Flat Blade Insulated Screwdriver Long Nose Pliers	3/8" Open End Wrench 5/16" Open End Wrench 0.030" Feeler Gauge External Retaining Ring Tool Precision Oiler With Lightweight Machine Oil (Such as 3-IN-1 Electric Motor Oil)
--	---

Removing Jammed Bills From The Bill Acceptor

First, try to determine where the bill is jammed in the transport.



CAUTION:

Always disconnect the power to the CBA-2 before turning the gear by hand. Be careful not to pinch your fingers between the gears.

Open the bill box and determine if the bill can be reached. If necessary, the transport can be turned by hand, either forward or reverse to remove the bill. To turn the transport by hand, turn the gear on the side of the transport. If the bill is jammed near the inlet, try to remove it by turning the transport by hand. If this does not free the bill; remove the transport from the unit and remove the inlet (see *Removing The Inlet* at the end of this section).

Bill Jamming Checklist

If frequent bill jamming occurs, perform the following checks and corrective procedures:

1. Check that the timing belts are not too loose or too tight (see *Timing Belt Tension Adjustment* in this section). Make sure the belts are positioned on the pulleys correctly.
2. Make sure the upper belts run freely and stay centered on the crowned rollers while the transport is running.
3. The inlet and bill track surfaces must be free of dirt, moisture, burrs, projections, and rough spots, which might catch edge of a bill or slow the bill down.
4. Check that the anti-cheat lever moves freely.
5. Check that the belts are clean and not glazed or slippery. If the belts are dirty or oily, clean them by wiping them with denatured alcohol.
6. Check that the driving pulleys are not loose on the shaft.
7. Check that the upper input roller is not loose on the shaft.
8. Check that the lower input roller has the correct amount of spring pressure and moves up and down without binding. The force to move the roller should be 150 to 200 grams.

CLEANING

The bill acceptor does not require routine cleaning, however, the inlet and track surface should be wiped with a clean soft lint free cloth each time the mechanism is removed for service. Due to the abrasive nature of currency, the magnetic head does not normally require cleaning. If the head does become dirty, use a clean cotton swab saturated with denatured alcohol or other suitable cleaning solution. Never soak the belts in cleaning solvents.

LUBRICATION

The bill acceptor does not require lubrication under normal use. If the transport turns hard or squeaks, apply one drop of light machine oil (such as 3:1 Electric Motor Oil or equivalent) to the following 19 areas:

- Gear shaft
- The nyliner bearings
- Each roller for the upper and lower belts
- Two blue bearings on the upper inlet shaft (These bearings can be reached by removing the inlet; see *Removing The Bill Inlet* in this section)

See *figure 4-4* for oiling locations.

Do not over lubricate.

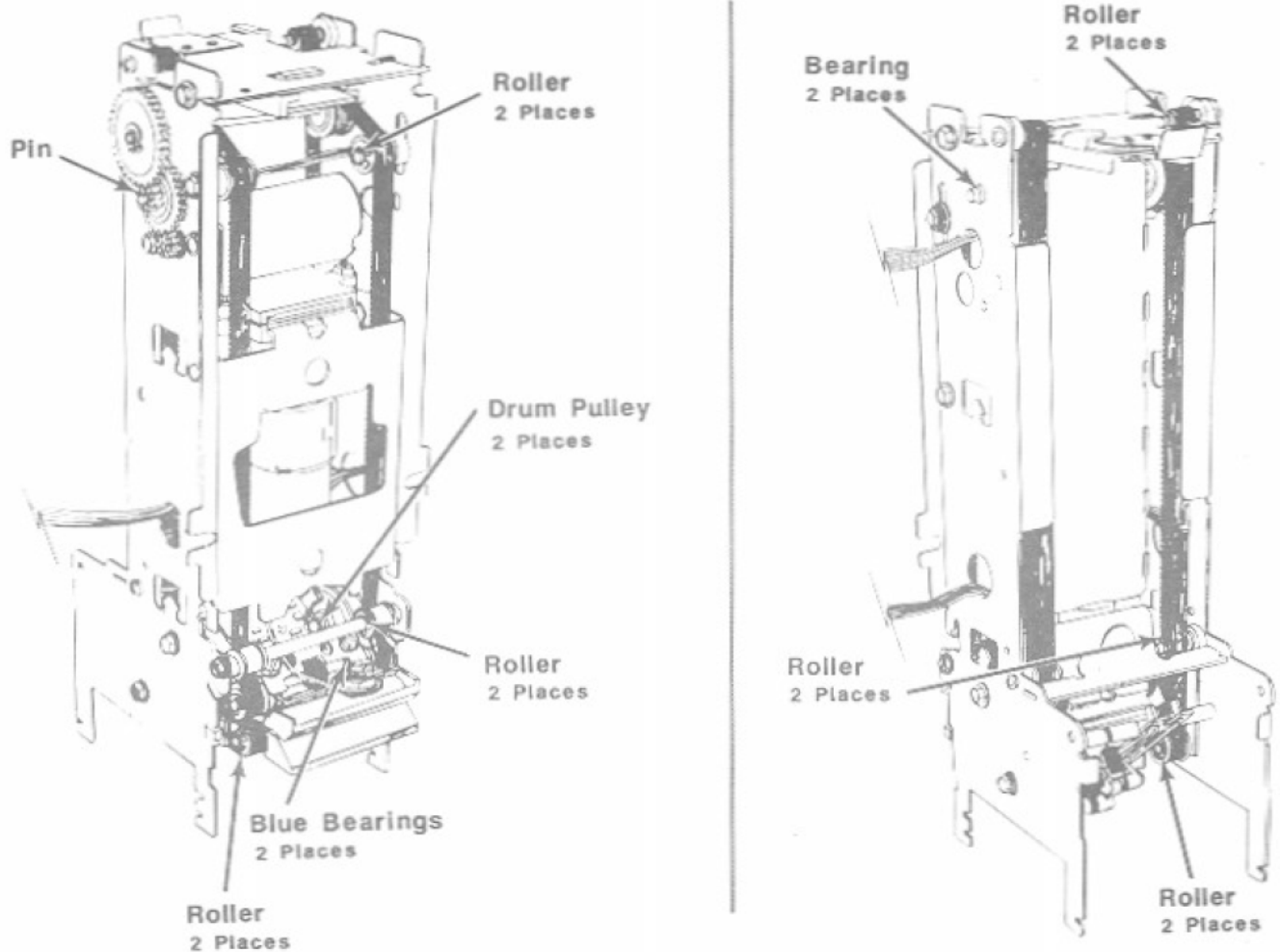

Figure 4-4. Oiling Locations

MECHANICAL ADJUSTMENTS

The bill acceptor transport mechanism does not require setup or routine adjustment; however, if the mechanism binds or slips, the following adjustments can be made. These adjustments should also be made if the transport is disassembled.

Belt Adjustment

Refer to *figure 4-5* for adjustment locations and the precision adjustment illustration.

COARSE ADJUSTMENT CHECK

Timing belts should be adjusted tight enough that they do not come off the pulleys, but not so tight that they put a load on the transport. This tension is achieved by adjusting the belt to the point that the slack in the belt is taken up.

PRECISION ADJUSTMENT CHECK

If this general adjustment procedure is not satisfactory, you may use the following precision adjustment procedure (refer to figure 4-5):

1. Apply a force of 118 grams to each belt. Each belt must deflect a distance of 3/16 inch.
2. Apply the force mentioned in step 1 with the end of a 1/4 inch diameter pin. The centerline of the pin must be centered on a line that is 1/4 inch from the stacker motor bracket and the pin must be centered on the belt. Apply the force in a direction perpendicular to the belt.
3. If the tension is not correctly set, loosen the screw(s) (A) in figure 4-5 so that the pulleys move freely in their slots. Adjust the pulley(s), tighten the screw(s), and recheck the belt deflection.

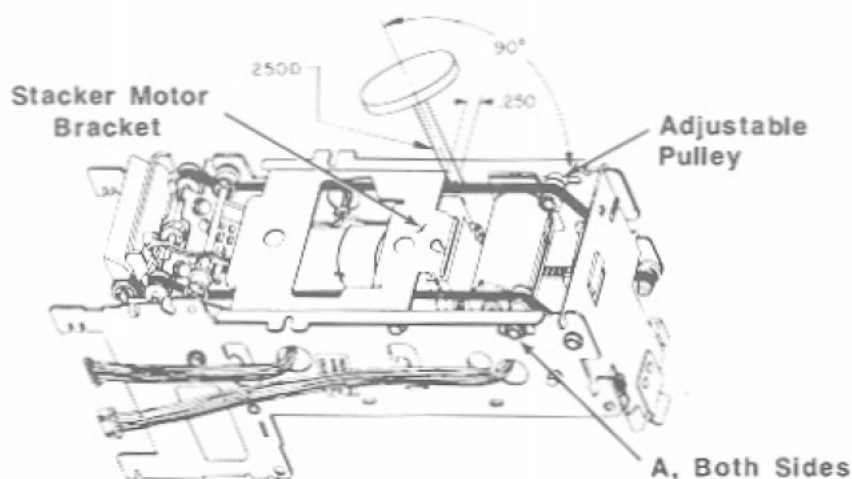

Figure 4-5. Timing Belt Tension Adjustment

Gear Backlash Adjustment

Check that the gears in figure 4-6 have a slight backlash of .008 to .012 inch. To adjust the gear backlash:

1. Loosen the two Hex-head adjusting screws (A) holding the motor.
2. Move the motor to obtain the correct backlash.
3. Tighten the two screws and recheck the gear backlash.

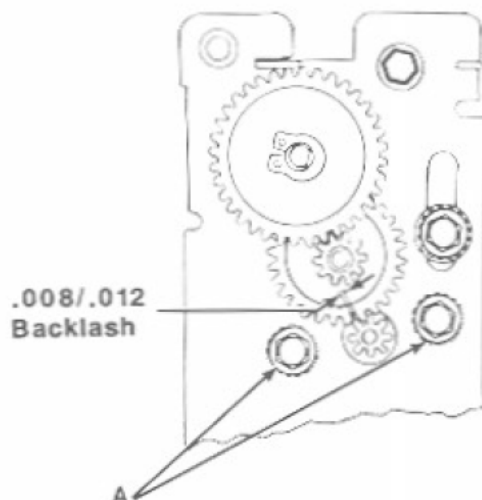

Figure 4-6. Gear Backlash Adjustment

Stacker Home Switch Adjustment

Check for a gap of $1/32$ (.030 inch feeler gauge) between the stacker switch arm and the stacker switch body as shown in *figure 4-7*.

If this clearance is not correct, adjust the stacker switch as follows:

1. Loosen the two adjusting screws as shown in *figure 4-7*.
2. Position the cam so that the switch arm rests on the raised lobe of the cam.
3. Insert a $1/32$ inch gauge (0.030 inch feeler gauge) between the switch arm and the switch body.
4. Hold the switch against the arm and tighten the two adjusting screws.

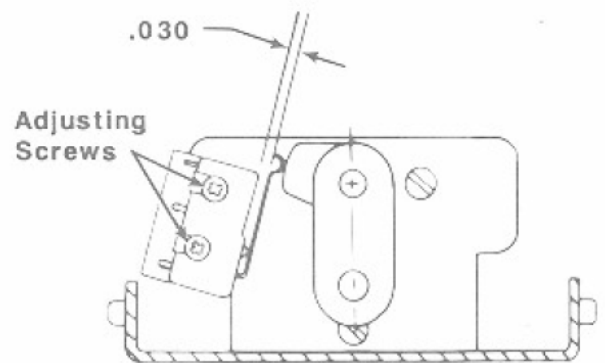

Figure 4-7. Stacker Home Switch Adjustment

Magnetic Head Alignment

The magnetic head is aligned to the upper track at the factory. If the head must be aligned or replaced, order the *Upper Track Harness And Cell Assembly* listed in *figure 5-4*.

ELECTRICAL ADJUSTMENTS

The CBA-2 has no electrical adjustments.

REMOVAL AND REPLACEMENT PROCEDURES

Removing the Inlet

1. Remove the countersunk screw that holds the inlet on the front of the transport (*see figure 4-8*).
2. Lift off the inlet.

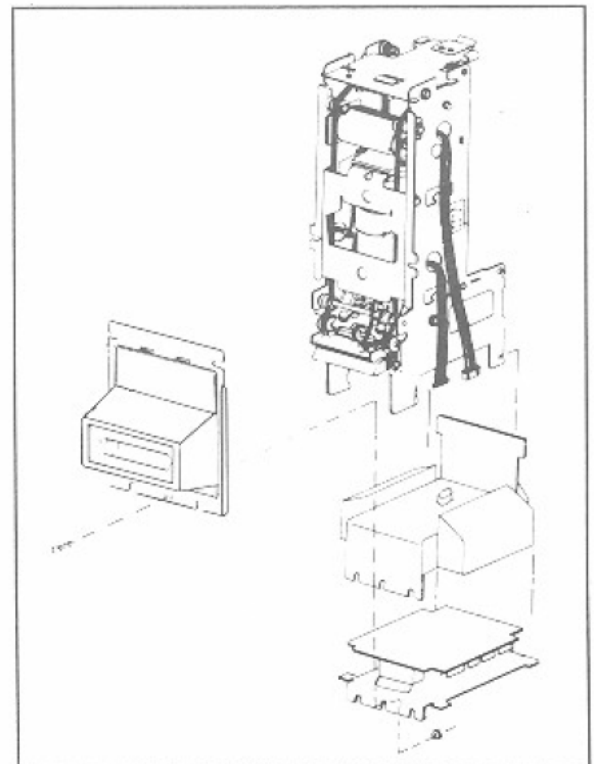

Figure 4-8. Removing The Bill Inlet

Removing The Water Shield

The water shield must be removed to gain access to the outer belts, rollers, and the lower harness and cell assembly. Remove the water shield as follows:

Remove the inlet (see *Removing The Inlet* in the preceding paragraph), disconnect the logic board wiring harnesses, and slide the logic board back; then, remove all three pieces (watershield, logic board, mounting bracket) at the same time.

Re-installing The Water Shield

1. Slide the water shield into its former position.
2. Re-install the logic board, reconnect the wiring harnesses, and re-install the inlet (see *figure 3-5*).

Removing The Lower Harness And Cell Assembly

1. Remove the water shield (see *Removing The Water Shield* in the preceding paragraph if you are not familiar with this procedure).
2. Push back on the catch (as shown in *figure 4-9*) to unhook the board, then remove the board.

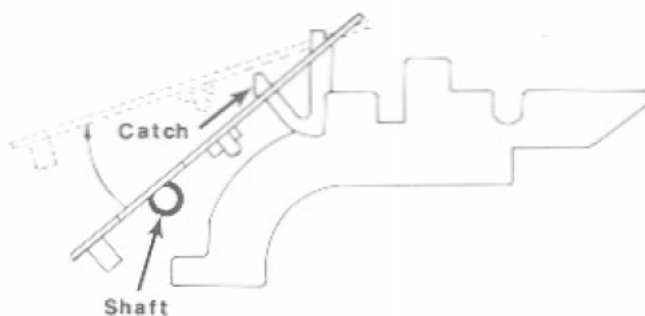

Figure 4-9. Removing The Cell Assembly

RE-INSTALLING THE LOWER HARNESS AND CELL ASSEMBLY

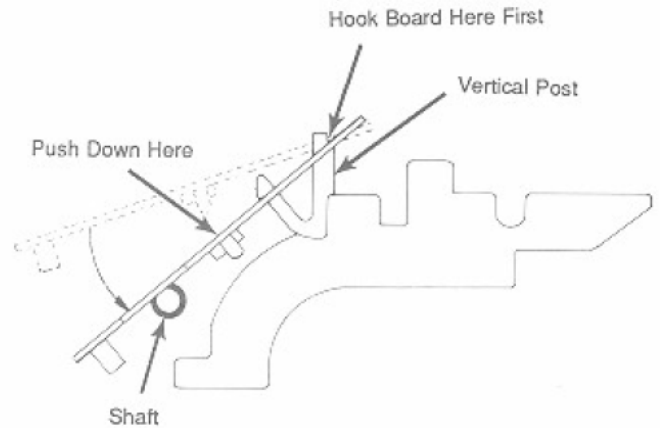
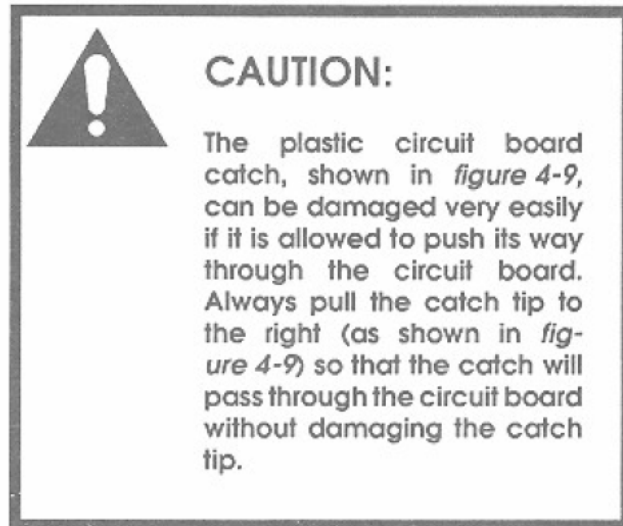

Figure 4-10A. Mounting The Cell Assembly

1. To replace the assembly on the lower track, set the transport upside down. Hook the board over the vertical post; then, pull the catch back and push down on the board to snap it under the catch (see *figure 4-10A*).
2. Re-Install the water shield (see *Re-installing The Water Shield* in this section if you are not familiar with this procedure).
3. Check to see that the catch is hooked over the board (A) and the board is setting in the recessed area on the shaft (B). See *figure 4-10B*.

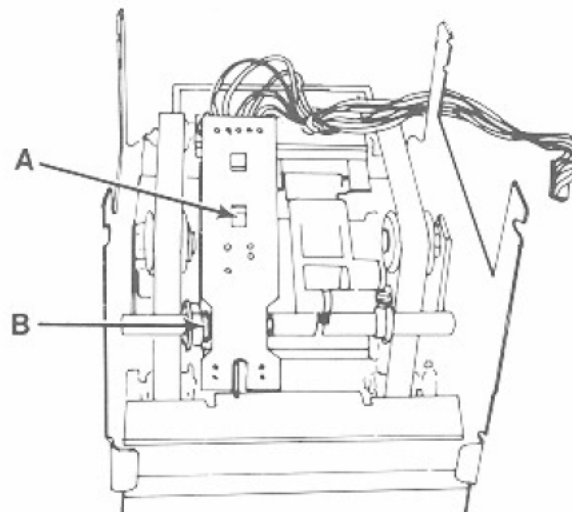

Figure 4-10B. Mounting The Cell Assembly

This page intentionally left blank.

TROUBLE SHOOTING

Logical troubleshooting minimizes effort caused by removing and replacing the wrong part. Many failures are caused by minor defects such as loose connections or dirty contacts. Check the following before replacing any parts:

1. Check that all plugs are firmly seated.
2. Check that connector pins are not bent, broken, or pushed through the back of the connector when mated.
3. Check that the coin acceptor operates properly. If the machine has disabled the coin acceptor, the CBA-2 will also be disabled.

TROUBLESHOOTING AIDS

This guide will help you isolate problems and return the bill acceptor to service as quickly as possible. *Table 4-2* lists common "Trouble" situations, their symptoms, and the most likely defective modules.

Rowe recommends that you replace defective modules with new modules, rather than try to replace individual components within the modules.

Table 4-2. Troubleshooting Chart

Trouble	Symptom	Probable Cause
<p>Transport motor does not start when a bill is inserted.</p>	<p>POWER LED on the logic board is not lit.</p>	<ol style="list-style-type: none"> 1. The problem is in the power supply or the harness to the CBA-2. 2. Defective logic board.
	<p>The STATUS LED is ON or is blinking.</p>	<p>The CBA-2 is not operational due to a fault condition (see the next section of this chart).</p>
	<p>The transport does not start, but a clicking sound is heard in the logic board.</p>	<ol style="list-style-type: none"> 1. An object is jammed in the transport mechanism. 2. Defective transport 3. Defective logic board
	<p>No sound or other indication that the transport is trying to run.</p>	<ol style="list-style-type: none"> 1. Defective V₁ cell 2. Defective logic board
<p>CBA-2 in SHUTDOWN</p>	<p>CBA-2 STATUS LED is ON steady</p>	<p>The CBA-2 has not been enabled by the controlling machine</p>
<p>In this state, the CBA-2 STATUS LED will be flashing ON and OFF. The number of flashes indicates the cause of the SHUTDOWN.</p>	<p>The CBA-2 STATUS LED flashes once.</p>	<ol style="list-style-type: none"> 1. An object is covering the V₁ cell in the transport. 2. Defective transport 3. Defective logic board
	<p>The CBA-2 STATUS LED flashes three times</p>	<ol style="list-style-type: none"> 1. An object is covering the V₃ cell. 2. Defective lower harness and cell assembly 3. Defective transport 4. Defective logic board

Table 4-2. Troubleshooting Chart

Trouble	Symptom	Probable Cause
<p>In this state, the CBA-2 STATUS LED will be flashing ON and OFF. The number of flashes indicates the cause of the SHUTDOWN. (cont'd)</p>	<p>The CBA-2 STATUS LED flashes four times</p>	<ol style="list-style-type: none"> 1. An object is activating the anti-pull-back lever in the transport 2. Defective lower harness and cell assembly 3. Defective lower harness and cell assembly 4. Defective logic board
	<p>The CBA-2 STATUS LED flashes five times</p>	<ol style="list-style-type: none"> 1. The bill stacker is full. 2. The bill stacker is jammed in the OFF-HOME position. 3. The bill stacker HOME switch is out of adjustment. 4. Defective bill stacker home switch 5. Defective logic board
	<p>The CBA-2 STATUS LED flashes seven times.</p>	<ol style="list-style-type: none"> 1. Motor speed could not be adjusted 2. Incorrect belt tension 3. Defective motor 4. Defective logic board
<p>The bill acceptor rejects a large number of valid bills. The CBA-2 STATUS LED will flash one or more times to indicate the cause of the rejection.</p>	<p>The CBA-2 STATUS LED flashes once after rejecting the bill.</p>	<ol style="list-style-type: none"> 1. Defective V₁ cell in the transport 2. Defective logic board
	<p>The CBA-2 STATUS LED flashes twice after rejecting the bill.</p>	<ol style="list-style-type: none"> 1. Defective lower harness and cell assembly 2. Defective logic board

Table 4-2. Troubleshooting Chart

Trouble	Symptom	Probable Cause
<p>The bill acceptor rejects a large number of valid bills. The CBA-2 STATUS LED will flash one or more times to indicate the cause of the rejection. <i>(cont'd)</i></p>	<p>The CBA-2 STATUS LED flashes three times after rejecting the bill</p>	<ol style="list-style-type: none"> 1. Defective V₃ cell in the transport 2. Defective logic board
	<p>The CBA-2 STATUS LED flashes four times after rejecting the bill.</p>	<ol style="list-style-type: none"> 1. An object is lodged in the transport. 2. Binding anti-pull-back lever 3. Defective lower harness and cell assembly 4. Defective logic board
	<p>The CBA-2 STATUS LED flashes five times after rejecting the bill.</p>	<ol style="list-style-type: none"> 1. Defective magnetic head or transport 2. Defective logic board
	<p>The CBA-2 STATUS LED flashes six times after rejecting the bill.</p>	<p>The bill denomination inserted has not been enabled.</p>
<p>Bills Jam Frequently</p>		<ol style="list-style-type: none"> 1. The anti-pull-back lever is not moving freely 2. The bill pressure roller is binding 3. The transport inlet or track surfaces have projections, or rough spots on them. 4. The transport belts are out of adjustment or dirty. 5. The transport belts are not centered on their rollers. 6. The transport upper input roller does not move up and down freely. 7. Defective power supply

Section 5: Troubleshooting

INTRODUCTION

The CD-100C Phonograph incorporates several modules which plug in for rapid service. The most likely causes of phonograph problems are:

1. Continuous or intermittent opens in a harness. The cause can be wiring, a terminal, or a bad terminal crimp.
 - Check that all plugs are firmly seated.
 - Check that connector pins are not bent, broken or pushed through the back of connectors when mated.
 - Check for bad solder joints, especially at connector pins.
2. A defective module (*see table 5-1*). Troubleshooting procedures are directed at module replacement, not repair.

Table 5-1. Replaceable Modules

Part No.	Description
40832201	Central Control Computer (CCC)
61048101	Mechanism Control and CD decoder
30955401	CD Player
40770609	Power Supply
40855001	Digital Display
40856101	Title Rack-KeyBoard Interface Assembly

TROUBLESHOOTING AIDS

The troubleshooting topics presented in this section are:

- A summary of the functions for each of the phonograph's replaceable modules
- A sequence of operation explanation and a Block Diagram (*figure 5-1*) to help you isolate the problem to a harness or a module.
- The RED LED STATUS lamps (*figure 5-2*).
- Instructions on how to use the ERROR and WARNING messages
- Modular Troubleshooting Charts that list the *Trouble*, *Symptom*, and *Probable Cause*
- A Sound System Quick Check

**NOTE:**

The CBA-2 service procedures are described in *Section 4* of this manual.

REPLACING THE CCC EPROM

If you have changed the CCC EPROM, use the following procedure to reset the CCC:

1. Put NORM/SERVICE switch to SERVICE and ON/OFF Power switch to OFF.
2. Press and hold keyboard 0 and 1 switches down and place the ON/OFF POWER switch power to ON; hold the 0 and 1 buttons down until the display shows LOADING DEFAULTS. Do not be concerned when the 14-04 WARNING appears, because it is just a status message indicating that the defaults were loaded. For a fresh start, clear out this warning (CODE 81).

FREE PLAY

1. Enter the SERVICE mode by setting the SERVICE switch to the SERVICE position.
2. Enter 55. This will place you in the PRICING menu, OPTION 5. Press and hold RESET and press 9. The display will change from FPLAY STATUS OFF to FPLAY STATUS ON. Press POPULAR to complete the change.

CD MODULE FUNCTIONS**Digital Display Module**

- A "dumb" controller (i.e. cannot make any decisions)
- Displays information sent by CCC

Title Rack-Keybaord Interface Module

- Contains the TITLE DISPLAY motor driver IC. The IC is controlled by the CCC.

CCC

- The master controller
- Has battery backed up RAM
- Controls all credit functions
- Stores all selections
- Controls all programming functions
- Makes all system decisions
- Mutes and unmutes the audio amplifier

Mechanism Control

- A slave controller
- Plays selections sent by the CCC
- Controls all mechanism functions
- Controls the CD player

CBA-2 Logic Board

- A slave controller
- Tells CCC when a valid bill is accepted.

Rowelink and the Power Bus (voltages, Commons & System Reset) are the only connections between CCC, mechanism control and CBA-2. Rowelink is a 2-wire communication channel that ties the system components together. The ROWELINK COMMAND (CCC), and ROWELINK TX (mechanism control), LED's should always be flickering.

SEQUENCE OF OPERATION

This sequence of operation describes the phonograph cycle and jobs performed by each module shown in the Block Diagram (*figure 5-1*).

In the Block Diagram, the TITLE DISPLAY switches are shown in the PAGE 1 position. The mechanism OUTER CAM and INNER CAM switches are shown in the MAGAZINE ROTATE position.

Step 1. Power is turned on, voltages and commons are applied to modules and components.

At Line Voltage	Voltages Labeled	Should Measure
115 VAC	28 VAC	26 to 30 VAC
115 VAC	+28 VDC	+23 to +30 VDC
95 to 135 VAC	+8 VDC	+8.2 to +9.9 VDC
115 VAC	9.5 VAC	8.75 to 10 VAC

Step 2. The modules sense power turn on, no selections or credit in memory, and the SERVICE switch is in the NORMAL position.

CCC

- +5 VDC LED lights
- BOARD ERROR LED flashes 3 times to indicate that ROM, RAM and real time calendar clock have tested OK.
- ROWELINK COMMAND LED flickers, indicating that serial communication commands are being sent from the master (CCC) to the slaves (mechanism control and CBA-2).

Mechanism Control

- +5V, +10V, -10V, +12V, -12V LEDES light.
- BOARD ERROR LED flashes 3 times to indicate that ROM, RAM and other checks have tested OK.
- ROWELINK TX (Rowelink response) LED flickers indicating that communication is occurring between the mechanism control (a slave) and CCC (the master). Each time it flickers, communication has successfully occurred.

CBA-2

- PWR LED lights
- STATUS LED flashes 1 time

Digital Display

- +5 VDC LED lights
- CCC serially sends information (via TX data, clock) and display shows:
 - Checksum = XXXX
 - RAM test passed
 - 0 (selections remaining)
- After 10 seconds, the moving messages ROWE, CD PHONOGRAPH and PLAY THE MUSIC appear.

Step 3. Customer deposits money. Play credit is established.

- Money is deposited
- CBA-2 tells CCC if a bill was validated and stacked.
- • CCC senses coins from the closed coin switches.

- • CCC uses pricing information (COIN SWITCH VALUES, PRICE LEVELS, PLAYS @ LEVEL and MULTIPLIER) stored in it, to convert money deposited into play credits.
- • CCC sends (via TX data, clock) credits to digital display and they appear above the SELECTIONS REMAINING legend.
- • CCC tells the mechanism control the money's value and the mechanism control increments the money counter.

Step 4. Customer makes a selection.

- • CCC determines that a switch is closed or open by sending out strobes and sensing returns.
- • Customer finds the selection that he wants to make by using the keyboard IN (> <) and OUT (< >) title page switches.
- • CCC sends out Strobes 1, 9 and 10 to the TITLE RACK-KEYBOARD INTERFACE.
- • The motor driver in the TITLE RACK-KEYBOARD INTERFACE uses Strobe 9 to control speed and Strobe 10 to control direction.
- • CCC determines when to stop the motor (i.e. a page has flipped) by sensing the state of the INDEX switch on return RET 1.
- • CCC determines when to change directions by sensing the state of the LIMIT switch on return RET 0, or using PAGE IN, OUT data in the ATTRACT menu.
- • Customer enters 4 digits (a 2-digit disc number and a 2-digit track number).
- • CCC senses the pushed keys by sending out Strobes 2, 3, 4, 5 and sensing returns RET 0, 1, 2 and 3.
- • Digital display shows digits as they are entered above the SELECTION BEING MADE.
- • Selection stored in the CCC's memory.
- • Credit is cancelled.
- • Selection is displayed for approximately 4 seconds after it is made.

Step 5. Selection is located and played.

- • CCC sends the selection to the mechanism control.
- • Mechanism Control searches for the disc.
- • Detent coil is energized and the magazine unlocks.
- • Magazine motor rotates the magazine.
- • Mechanism control SCAN/TRANSFER LED lights.
- • Digital display shows the selection playing as — — — — .
- • Mechanism control locates the disc by counting gear teeth interruptions of the INDEX optical switch light beam.

- Disc located and transferred to the play position.
- • Magazine motor stops and the magazine locks (detented).
- • Transfer motor runs and the disc is placed in the play position.
- • Outer cam Common connected to the N.O. contact.
- Mechanism control SCAN/TRANSFER LED goes OFF.
- Mechanism control tells the CDM-4 what track (i.e. selection) to play.
- CDM-4 tells the mechanism control that the track has been located.
- Selection plays
- • Mechanism control tells the CCC that the selection is playing.
- • CCC unmutes the audio amplifier.
- • Selection is erased from CCC's memory.
- • Digital display shows that the selection is playing.
- • Mechanism control monitors the disc condition and tells the CCC if disc problems occur.

Step 6. Selection ends, the disc returns to magazine, the CCC searches selection memory.

- Mechanism control tells the CCC that the selection is over.
- CCC mutes the audio amplifier
- Transfer motor runs and the disc is returned to the magazine
- Inner cam Common connects to the N.O. contact when the disc is in the magazine.
- CCC searches its selection memory. If it contains one or more selections, steps 5 and 6 are repeated.

Step 7. Phono returns to STANDBY and AUTOPLAY timing begins.

- All selections have played.
- Digital display shows moving messages: ROWE, CD PHONOGRAPH, and PLAY THE MUSIC.

This page intentionally left blank.

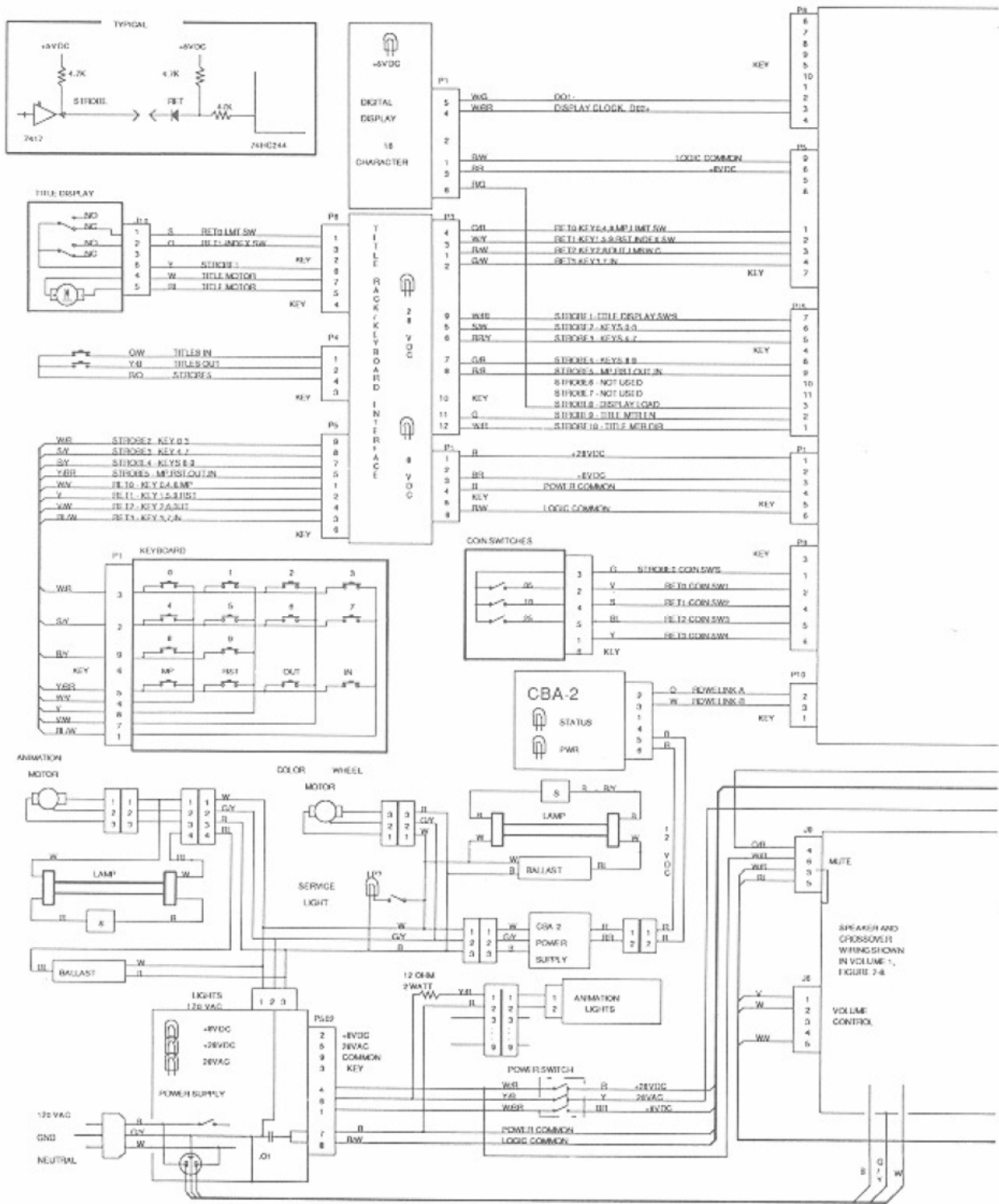

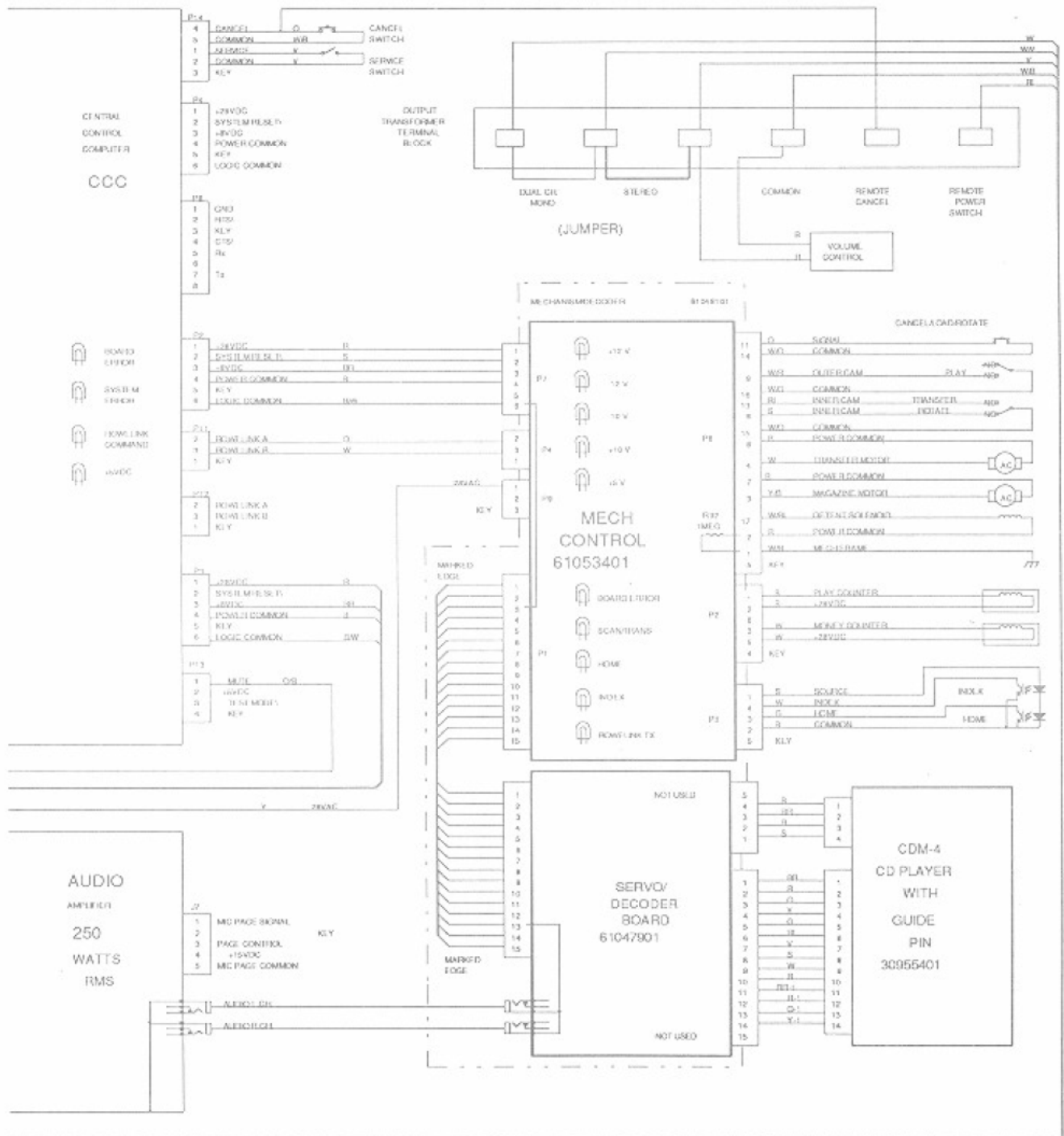

Block Diagram
Figure 5-1. CD-100C

STATUS LAMPS

The red LED indicators are connected to various strategic points in the phonograph's circuits to indicate the status of power and signal circuits.

Main Power Supply LED's

+8 Volts DC
+28 Volts DC
28 Volts AC

These indicators light when their corresponding voltages are present and no wiring shorts are present.

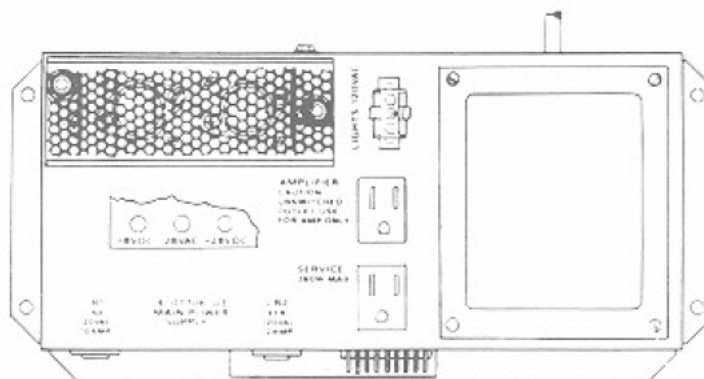

Main Power Supply

Mechanism Control And CD Decoder

OPT. SW. INDEX

Lights when the index section of the optical switch sees a tooth space of the magazine drive gear. Flickers when the magazine rotates.

OPT. SW. HOME

Lights when the HOME section of the optical switch sees the hole in the magazine drive gear. Flickers when the magazine CD Position 99 passes the transfer position.

5V, +10V, -10V, +12V, -12V

Indicate supply voltages and all should always be lit.

ROWELINK TX

Flashes when the CD mechanism is transmitting to the CCC.

BOARD ERROR

Blinks on and off three times on power up. Any other time, this LED indicates that a fatal mechanism error (phonograph out of service) has occurred.

SCAN/TRANSFER

Lights when either the scan or the transfer motor is activated.

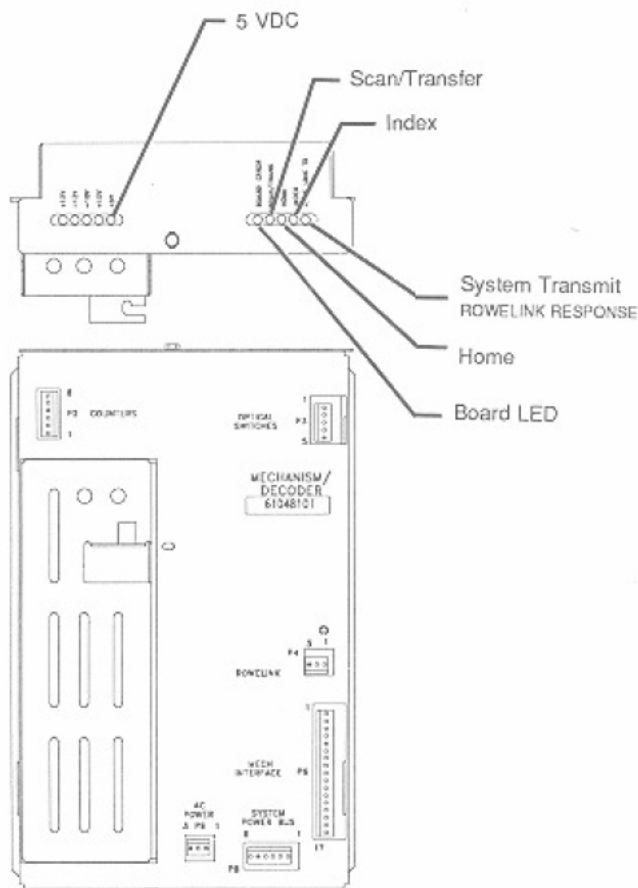

Central Control Computer

- BOARD ERROR** Blinks 3 times on power up. If it stays on, an error has been detected.
- SYSTEM ERROR** Lit only when the phonograph is out of order. The type of error that caused the shutdown can be examined from the SERVICE mode.
- ROWELINK COMMAND** Flashes when the CCC is transmitting messages to slave devices (i.e. mechanism, CBA-2)
- +5 VDC** +5 VDC is present.

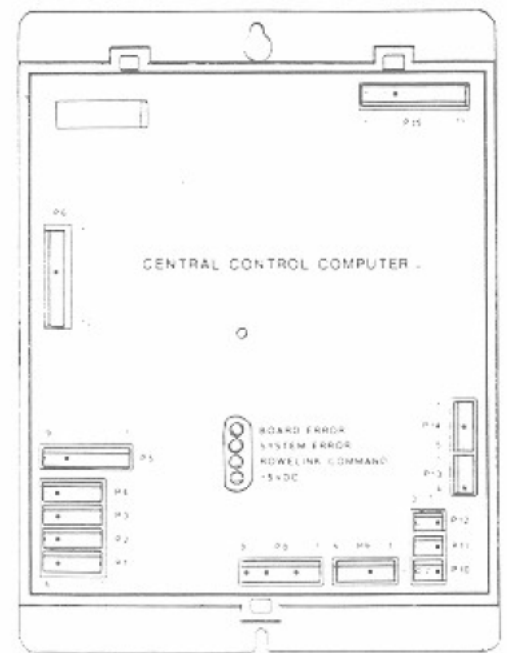

Central Control Computer

Digital Display

- +5 VDC** +5 VDC is present.

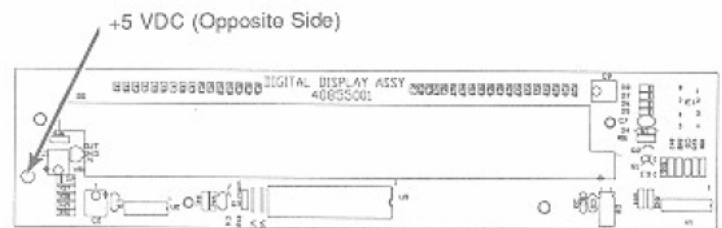

CBA-2

- BA STATUS** Blinks one time at power up then stays off. See Section 4 Troubleshooting if always lit or flashing.
- PWR** Voltage is present.

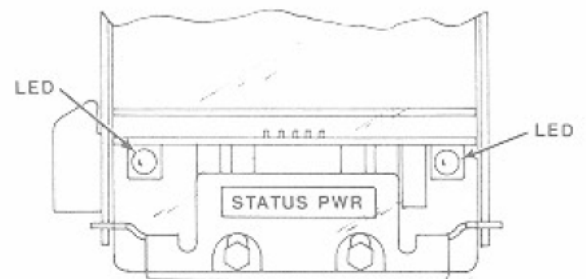

Figure 5-2. Status Indicators

ERRORS AND WARNINGS

Basic Concepts

When you switch to SERVICE mode, you will see one of two displays:

- If the phonograph has not encountered any errors or warnings, * SERVICE MODE * will be displayed.
- If the phonograph has encountered errors or warnings, --ERRORS EXIST-- will be displayed. This message will only appear as you enter SERVICE mode, and it will not change menu or command operation.

ERRORS (ERR)

- Cause phonograph shutdown and show the OUT OF ORDER message.
- Usually require a service call, component replacement, adjustment, or harness repair.
- Are always shown as active (A), even if they cleared up.

If you turn power OFF and ON, the phonograph will operate if error cleared up. If error is still present, the phonograph will shutdown. Errors that clear up do not require service unless phonograph is malfunctioning.

WARNINGS (WARN)

- Do not cause phonograph shutdown.
- Phonograph may or may not operate.
- Service personnel are made aware by the --ERRORS EXIST-- message appearing upon entering the service mode.
- Shown as active (A) until the problem clears up.
- Not active (N) warnings do not require service unless phonograph is malfunctioning.

VIEWING THE ERRORS AND WARNINGS



NOTE:

1. If the CCC thinks that a key other than RESET is closed, it will not accept other keys. This problem will not allow you to view the error/warnings. The probable cause is a short in the keyboard, a short in RET 0, 1, 2 or 3 wiring, defective CCC, or a short in < > page < switch or wiring.
2. The viewing procedure can be started over by holding RESET and repeatedly pushing POPULAR until the display shows * SERVICE MODE *. Then start at step 2.

Steps

1. Enter SERVICE mode
2. Type 8
3. Type 0 (*see note 1*)
4. Push POPULAR

Display Shows

--Errors Exist--

* STATUS *

Error History

X WARN XX-XX XX

A = Active

N = Not Active

Source of warning

Type of warning

Number of occurrences

OR

X ERR XX-XX XX

A = Active

Source of error

Type of error

Number of occurrences

5. Hold RESET, push 9

START XX:XX XX/XX

Time of first occurrence

Month/day of first
occurrence

6. Hold RESET, push 9

END XX:XX XX/XX

Time it last cleared up
(not active)Month/day it last cleared up
(not active)00:00 00/00 if first
occurrence and still active,
or ERR message

7. Hold RESET, push 3

Next ERR or WARN if a dif-
ferent one exists. Otherwise
stays the same.

8. Repeat steps 5, 6, and 7 as often as necessary (*See the Notes that follow*).

**NOTE:**

3. You can review the WARN or ERR, START or END by holding RESET and pushing 9 as often as desired.
4. Steps 4 and 5 can be skipped.
5. Hold RESET, push 2 to search backwards through errors.

EXAMPLE 1:

N WARN 06-02 15
 START 14:30 06/01
 END 15:00 06/01

Message means

- CBA-2 thinks bill transport V1 cell was blocked 15 times.
- First occurrence was 2:30 p.m. on June 1.
- Last occurrence cleared up 3:00 p.m. on June 1.

Probable cause

- Someone tried to obtain free credit by inserting a foreign object.

EXAMPLE 2:

A ERR 05-63 03
 START 09:10 07/13
 END 00:00 00/00

Message means

- The CCC has sent messages (via the ROWELINK) to the mechanism control, but the CCC has not received any response for 1 minute.
- First occurrence was 9:10 a.m. on July 13.

**NOTE:**

6. A (Active symbol) always proceeds ERR, even if the problem is not active now.
7. An ERR message always shows 00:00 and 00/00 for the END time and date.

ERROR AND WARNING SUMMARY

The following list summarizes all possible errors and warnings that can be displayed. For details of causes and corrective action, see *Description Of Errors/Warnings And Probable Causes* that follows this summary.

Coin Switches (01)

01-17	#1 coin switch	05-56	Index LED
01-18	#2 coin switch	05-57	Index LED
01-19	#3 coin switch	05-58	Home LED
01-20	#4 coin switch	05-59	Home LED
01-31	Multiple coin switches	05-62	CDM-to-CCC communication lost
		05-63	Mech-to-CCC communication lost
		05-64	Gripper bow position undetermined

Keyboard Switches (02)

02-16	Key 0
02-17	Key 1
02-18	Key 2
02-19	Key 3
02-20	Key 4
02-21	Key 5
02-22	Key 6
02-23	Key 7
02-24	Key 8
02-25	Key 9
02-26	Most Popular key
02-27	Reset key
02-28	<> key
02-29	>< key
02-31	Multiple keys
02-32	Cancel button

Mechanism Controller (05)

05-05	Mech. cannot determine magazine position
05-08	EPROM checksum error
05-09	RAM test failed.
05-10	CDM communication invalid
05-25	Cause undetermined

Mechanism Fatal Errors

These error codes (05-50 through 05-64) will cause a system reset and after five errors, the phonograph will go out of order.

05-50	Inner cam switch
05-51	Inner cam switch
05-52	Outer cam switch
05-53	Outer cam switch

CBA-2 (06)

06-01	Communication to the CBA-2 has been lost
06-02	V1 cell or inlet cell
06-03	Jammed bill!
06-04	Bill stacker is full
06-05	Cause undetermined

Wallbox Controller (07-10)

07-01	Communication to wallbox #1 has been lost
08-01	Communication to wallbox #2 has been lost
09-01	Communication to wallbox #3 has been lost
10-01	Communication to wallbox #4 has been lost

IR Remote (11)

11-01	Communication to the IR remote has been lost.
-------	---

Central Control Computer (14)

14-01	EPROM checksum error
14-02	RAM failed
14-03	Real time clock error
14-04	Factory defaults have been loaded
14-05	RAM checksum error
14-06	Low battery

Description Of Errors/Warnings And Probable Causes

SOURCE 01 (COIN SWITCH WARNINGS)

WARN	01-17	#1 coin switch
	01-18	#2 coin switch
	01-19	#3 coin switch
	01-20	#4 coin switch
	01-31	Multiple coin switches

Message Means:

CCC thinks one or more coin switches are closed for more than 5 seconds.

Probable cause:

1. A manual operation of coin switches
 2. A jammed coin or switch
 3. A short in wiring
 4. A defective CCC
-

SOURCE 02 (KEYBOARD WARNINGS)

WARN	02-16	Key 0
	02-17	Key 1
	02-18	Key 2
	02-19	Key 3
	02-20	Key 4
	02-21	Key 5
	02-22	Key 6
	02-23	Key 7
	02-24	Key 8
	02-25	Key 9
	02-26	MOST POPULAR key
	02-27	RESET key
	02-28	< > key
	02-29	> < key
	02-30	-----
	02-31	Multiple keys
	02-32	External CANCEL button

Message Means:

CCC thinks one or more switches were closed for more than 10 minutes.

Probable cause:

1. Someone held it closed. Nothing needs repairing or replacing.
2. A short in associated wiring (*see the Block Diagram in this section*).
3. A defective CCC.

SOURCE 03—04 NOT DESIGNATED

SOURCE 05 (MECHANISM ERRORS/WARNINGS)

WARN 05-05

Message Means:

Both the Index and Home signals are changing, but the mechanism is unable to determine the magazine position.

Probable cause:

1. A defective optical switch
 2. A loose connection wire/terminal at OPTICAL switch connector on the mechanism controller.
 3. A defective mechanism control
-

WARN 05-08 EPROM checksum warning

Message Means:

Checksum test failed

Probable cause:

1. A failed EPROM
 2. A defective mechanism control.
-

WARN 05-09 RAM test failed

Message Means:

RAM test failure

Probable cause:

A defective RAM or mechanism control.

WARN 05-10 CDM communication invalid

Message Means:

The mechanism control is receiving invalid communications from the servoprocessor on the decoder board.

Probable cause:

1. Neon signs
 2. RF signals from radio station(s), CB radio(s), arcing wires, etc.
-

Warn 05-25 Unspecified Warning

ERR 05-50 Inner Cam switch always closed
05-51 Inner Cam switch always open
05-52 Outer Cam switch always closed
05-53 Outer Cam switch always open

Message Means:

Mechanism control thinks a switch is not working.

Probable cause:

1. A switch
 2. A wiring short or open
 3. The mechanism control
-

ERR 05-56 Index LED always OFF
05-57 Index LED always ON
05-58 Home LED always OFF
05-59 Home LED always ON

Message Means:

Mechanism control thinks that the optical switch is defective.

Probable cause:

1. The optical switch
 2. A wiring short or open
 3. The mechanism control
-

ERR 05-62 CDM communication failure

Message Means:

The servo processor, on the decoder board, has stopped all communications with the mechanism control for 20 seconds.

Probable cause:

1. The decoder board is not getting power
 2. A failure in the mech controller
 3. A failure in the decoder board
-

ERR 05-63 Mech communication failure

Message Means:

The CCC has sent messages (via the Rowelink) to the mechanism controller, but the CCC has not received any response for one minute.

Probable cause:

1. Rowelink harness failure in the CCC harness
2. The mech control has failed
3. CCC (or a module that uses ROWELINK) has failed.

ERR 05-64

Message Means:

Both the inner and outer cam switches are operating, but the gripper bow position is uncertain.

Probable cause:

1. A defective cam switch
 2. A loose connection in wire/terminal at cam switch
 3. A defective mechanism control
-

SOURCE 06 (CBA-2 WARNINGS)

WARN 06-01

Message Means:

CBA-2 Communication failure

Probable Cause:

1. A loose connection in wire/terminal at the Rowelink communication line.
 2. A defective CBA—2.
-

WARN 06-02

Message Means:

CBA-2 control unit thinks that the transport V1 cell is blocked.

Probable cause:

1. An object in transport covering V1 cell
 2. A defective transport
 3. A defective CBA-2
-

WARN 06-03

Message Means:

CBA-2 control unit thinks that a bill is jammed in the transport.

Probable cause:

1. An object is or was in transport activating anti-pullback lever.
2. A defective transport
3. A defective CBA-2

WARN 06-04

Message Means:

CBA-2 thinks that the bill stacker is full.

Probable cause:

1. The bill stacker is full
 2. The bill stacker is jammed in the OFF HOME position
 3. The bill stacker HOME switch is out of adjustment
 4. A defective bill stacker
 5. A defective CBA-2
-

WARN 06-05 Unspecified Warning

SOURCE 07 (WALLBOX ADDRESS 70)

WARN 07-01 CCC lost communication with wallbox or concentrator for more than 1 minute

SOURCE 08 (WALLBOX ADDRESS 71)

WARN 08-01 CCC lost communication with wallbox for more than 1 minute

SOURCE 09 (WALLBOX ADDRESS 72)

WARN 09-01 CCC lost communication with wallbox for more than 1 minute

SOURCE 10 (WALLBOX ADDRESS 73)

WARN 10-01 CCC lost communication with wallbox for more than 1 minute

Message Means:

Rowelink communications was established with this wallbox or concentrator then it was lost for more than 1 minute.

Probable Cause:

1. The Rowelink wiring to the concentrator (or wallbox)
 2. A wallbox power supply
 3. A wallbox or concentrator
-

SOURCE 11 (IR REMOTE WARNING)

WARN 11-01 IR Remote communication failure

Message Means:

Rowelink communications was established with the IR remote then was lost for more than 1 minute.

Probable Cause:

1. Defective Rowelink harness between the P10 of the CCC and P6 of the IR Remote.
2. Defective power harness between P1 of the CCC and P4 of the IR Remote.
3. Defective IR Remote assembly.

SOURCE 12-13 NOT DESIGNATED**SOURCE 14 (INTERNAL CCC WARNINGS)**

- 14-01 CCC EPROM checksum test failed
- 14-02 CCC RAM test failed
- 14-03 CCC real-time clock failure
- 14-04 CCC factory defaults requested and loaded
- 14-05 CCC programmed RAM checksum test failed
- 14-06 CCC battery voltage is low

Message Means:

All except 04 indicate a CCC internal fault. The 04 indicates factory defaults were loaded into programmed RAM because: someone used the factory load procedure (see replacing the EPROM).

Probable cause:

1. A defective CCC for all except 04
2. A defective CCC if 04 occurs frequently
3. Someone loaded factory defaults, causing 04 warning.

CLEARING ERROR/WARNINGS FROM MEMORY

Error/warnings stored in the phonograph's memory can be cleared by:

STEPS	DISPLAY SHOWS
1. Enter SERVICE mode	-- ERRORS EXIST --
2. Press 8.	* STATUS *
3. Press 1.	* CLEAR ERRORS *
4. Press POPULAR.	CLEAR ERRORS
	(Will blink and then reappear)

**NOTE:**

If already in SERVICE mode, or you want to start over, hold RESET and repeatedly press POPULAR until display shows * SERVICE MODE *. Then start at step 2.

DISC CONDITIONS

Basic Concepts

Compact Discs are very rugged, but sometimes they develop problems similar to vinyl records. Skips and dropouts are not uncommon CD faults and may be caused by: a dirty disc, dirty CD player lens, or CD manufacturing defects. On rare occasions, the CD player may be unable to play any tracks on a disc. This failure to play any tracks may have the same cause as skips and dropouts.

Programmable Disc Condition Logging

The CD-100C has a built-in disc condition logging feature that records disc play problems found on a disc or track. Three programmable options determine when these conditions are placed into the Disc Condition Log:

SKIP LOG (SERVICE CODE 35)

The number of skips, over one second, to occur before recording the error in the condition log. The recommended setting is 3.

SKIP CANCEL (SERVICE CODE 36)

The number of skips, greater than one second, to occur before recording the error in the condition log and canceling the selection. The recommended setting is 5.

TIME CANCEL (SERVICE CODE 37)

The absolute time difference, in seconds, between the current playing position, coming off the CD, and the running time. The recommended setting is 10.

Factory Settings

The factory settings for the SKIP LOG, SKIP CANCEL, and TIME CANCEL are 99. The reason for the difference between defaults and recommended settings is that we want the CD-100C, when shipped, to play discs of practically any condition without early canceling.

Non-Programmable Disc Condition Logging

Four non-programmable disc condition events are also recorded in the condition log. These events are:

LOGGED TRACK NUMBER EQUALS 00

This entry in the log means that the CD player was unable to read the CD Table Of Contents (TOC).



NOTE:

The TOC is read every time the disc is placed on the turntable. The TOC contains the location of each track on the disc, so without it the player is unable to play any track.

LOGGED CANCL AND SKIP EQUALS 99

This entry means that the CD player was able to read the TOC, but was unable to locate the track.

LOGGED CANCL EQUALS 99 AND SKIP EQUALS 77

This means the disc stopped spinning while playing

LOGGED CANCL EQUALS 99 AND SKIP EQUALS 88

This means tracking was lost when the disc was playing

The CD-100C has an automatic method to lock out selections that have logged too many errors. You can set this number of condition occurrences to any number from 1 to 99. Once the LOCKOUT COUNT, Code 693, has exceeded the number of occurrences on a selection, that selection is automatically placed into LOCKOUTS list, Code 60. To remove a condition generated lockout, refer to the Section 2 on editing the Lockout List or reinitialize the disc when using menu command 31.

Viewing Disc Conditions

Steps	Display Shows
1. Enter SERVICE mode.	* SERVICE MODE *
2. Type 8.	* STATUS *
3. Type 6.	DISC CONDITIONS
4. Press POPULAR	- NO CONDITIONS
	-OR-
	SEL ditr OCC oo
	The small letters mean:
	di - Disc number
	tr - Track number
	oo - Number of occurrences
5. Hold RESET, press 9	CANCL tt SKIP ss tt - Absolute time difference, in seconds, when the condition was logged. ss - Number of skips, greater than one second in duration, when the condition was logged.
6. Hold RESET, press 9	TIME hh:mi mo/dd hh - Hour when last condition occurred. mi - Minute when last condition occurred. mo - Month when last condition occurred. dd - Day when last condition occurred.
7. Hold RESET, Press 3 to view next disc condition.	
8. Hold RESET, Press 2 to view previous disc condition.	
9. Repeat steps 5, 6, 7, and 8 as often as necessary.	

Example 1:

SEL 1500 OCC 05
CANCL 00 SKIP 00
TIME 12:15 7/19

Condition Means

The CD player could not read the TOC (track number equals 00) of disc 15 on 5 selected occasions. The most recent condition was logged on July 19th at 12:15 (24 hour time).

Probable Cause

1. Disc installed backward.
2. Absent disc. This disc location may not have been initialized, allowing it to be accidentally selected.
3. Dirty disc. For this type of a condition the dirt would be located around the inner most diameter of the disc. This is where the TOC information is located.
4. Dirty CD player LASER lens. Expect to see various conditions logged on many of the discs selected (*see CD Player Lens in Section 3 for details*).

Remedy

1. Check to see if the disc was inserted backward. If inserted backward, re-install it correctly and initialize that disc.
 2. Check to see if the disc is present. If not present, initialize that disc location.
 3. Remove the disc from the magazine, then inspect the inner diameter, TOC area, for dirt or damage. If you find dirt or damage clean it up. See disc cleaning section. Clear out the conditions and select a track on this disc to see if the CD player is able to read the TOC. If the CD player is still unable to read the TOC, try further cleaning or replace the disc.
 4. Clean the CD player LASER lens (*see CD Player Lens in Section 3 for details*).
-

Example 2:

SEL 1505 OCC 01
CANCL 99 SKIP 99
TIME 12:30 7/12

Condition Means

The CD player read the TOC successfully, but was unable to start playing the track (no music would have been heard) on 1 occasion. The most recent condition was logged on July 12th at 12:30 (24 hour time).

Probable Cause

1. The disc is dirty. For this type of a condition the dirt would be located some where between the inner most diameter of the disc and the track selected. See disc cleaning section.

2. Dirty CD player LASER lens. Expect to see various conditions logged on many of the discs selected (*see CD Player Lens in Section 3 for details*).

Remedy

1. Remove the disc from the magazine, then inspect it for dirt or damage. If you find dirt or damage clean it up. See disc cleaning section. Clear out the conditions and select 1505 again to see if the CD player is able to play it. If the CD player is still unable to play it, try further cleaning, lock out tracks 5 and greater on disc 15, or replace the disc.
 2. Clean the CD player LASER lens (*see CD Player Lens in Section 3 for details*).
-

Example 3:

```
SEL 2302 OCC 01
CANCL 10 SKIP 3
TIME 23:30 5/20
```

Condition Means

1. The CD player was playing selection 2302, but while it was playing 3 skips occurred, skips over 1 second, with an overall time loss of 10 seconds on 1 occasion. The most resent condition was logged on May 20th at 23:30 (24 hour time).

Probable Cause

1. Dirty disc. For this type of a condition the dirt would be located some where within track 2.
2. Dirty CD player LASER lens. Expect to see various conditions logged on many of the discs selected (*see CD Player Lens in Section 3 for details*).
3. An outside jarring of the jukebox.

Remedy

1. Remove the disc from the magazine, then inspect it for dirt or damage. If you find dirt or damage clean it up. See disc cleaning section. Clear out the conditions and select 2302 again to see if the CD player is able to play it. If the CD player is still unable to play it, try further cleaning, lock out track 2 on disc 23, or replace the disc.
2. Clean the CD player LASER lens (*see CD Player Lens in Section 3 for details*).

Clearing Disc Conditions From Memory

Disc condition messages stay in memory until you perform the following steps:



NOTE:

If already in SERVICE mode, or you want to start over, hold RESET and repeatedly press POPULAR until display shows * SERVICE MODE *. Then start at step 2.

STEPS

1. Enter SERVICE mode
2. Press 8.
3. Push 7.
4. Press POPULAR.

DISPLAY SHOWS

* SERVICE MODE * or -- ERRORS EXIST --
* STATUS *
* CLEAR CONDITIONS *
CLEAR CONDITIONS
(will blink and then reappear)

TROUBLESHOOTING CHARTS

One of the best ways to isolate a problem is to determine the exact state of the phonograph when the failure occurs. This means recording the condition of digital display, STATUS LED's, gripper bow, detent pawl, magazine, cam switches, etc.

This information can help you identify the cause of intermittent or continuous failures.

Refer to figure 5-2 for descriptions and locations of the LED's referred to in the Modular Troubleshooting Chart that follows in table 5-2.

The chart has the following three columns:

- The trouble column lists different types of failures.
- The symptom column shows the state of the phonograph when the failure occurs.
- The last column shows the probable cause.

Refer to figure 5-1, the Block Diagram for harnessing information.

Table 5-2. Modular Troubleshooting Chart

Trouble	Symptom	Probable Cause
Phonograph fails to operate when power is turned ON	LED's on power supply and fluorescent lights fail to light	<ol style="list-style-type: none"> 1. Rear power switch OFF 2. Plug not in wall 3. Wall circuit is dead 4. 10 amp circuit breaker tripped 5. Wiring to rear power switch 6. Rear power switch
	LED's on power supply fail to light but fluorescent lamps are ON	<ol style="list-style-type: none"> 1. 2 amp circuit breaker tripped 2. Power supply 3. 28 VAC overload from magazine, transfer or T.T. motor
	The +8 VDC or +28 VDC LED on power supply fails to light but lights when phono harness at power supply is unplugged	<ol style="list-style-type: none"> 1. Central control computer 2. Mechanism control 3. Digital display 4. Title Rack/Keyboard Interface 5. Power Supply 6. Service switch 7. Short circuit in wiring 8. Detent coil 9. Money or play counter
<div style="display: flex; align-items: flex-start;"> <div style="margin-right: 20px;">  </div> <div> <p>NOTE:</p> <p>To locate the problem, reconnect the phono harness and unplug the connectors in the order shown in the following 10 steps. If the LED lights, replace the last module unplugged or repair the short in the harness.</p> </div> </div>		

Table 5-2. Modular Troubleshooting Chart

Trouble	Symptom	Probable Cause
Phonograph fails to operate when power is turned ON	The +8 VDC or +28 VDC LED on power supply fails to light but lights when phono harness at power supply is unplugged	<ol style="list-style-type: none"> 1. Digital display module (P1) 2. Harness at the CCC (P5) 3. Title Rack/Keyboard Interface Module (P1) 4. Harness at CCC (P1) 5. Harness at mechanism control (P12 and P6). Check harnesses, detent coil, and counters. 6. Mechanism control module (P7) 7. Harness at CCC (P2) 8. CCC module (P3) 9. Check power switch and wiring between it, the power supply, and CCC (P3). 10. Replace the power supply or the circuit board inside it.
	CCC ROWELINK COMMAND LED is always OFF or always ON (not flickering)	Central control computer
	CCC ROWELINK COMMAND LED flickering 4 times a second and the display shows OUT OF ORDER, and Error A ERR 05-63 is logged in	<ol style="list-style-type: none"> 1. If the mechanism ROWELINK TX LED is flickering, the cause is: <ol style="list-style-type: none"> a. mech control b. open wiring in mechanism 2. If the mechanism ROWELINK TX LED is not flickering, the cause is: <ol style="list-style-type: none"> a. mechanism control b. CBA-2 c. a short in the ROWELINK wiring

Table 5-2. Modular Troubleshooting Chart

Trouble	Symptom	Probable Cause
<div style="display: flex; align-items: flex-start;"> <div style="margin-right: 10px;">  </div> <div> <p>NOTE:</p> <p>The CCC sends OUT OF ORDER to the display and logs the A ERR 05-63 Error one minute after power up if it cannot establish Rowelink communication with the mechanism control and the phonograph is in the NORMAL mode (i.e. not SERVICE).</p> <p>To isolate the problem to a module or its associated Rowelink wiring, put the SERVICE switch in the SERVICE position and unplug the connectors in the following order. If the mechanism ROWELINK TX (TRANSMIT) LED starts flickering, replace the last module unplugged or repair the short in the harness. If the LED never starts flickering, the cause is a defective mechanism control, CCC, or a short in the Rowelink harness between them.</p> <ol style="list-style-type: none"> 1. Unplug the CBA- 2. </div> </div>		
Magazine does not rotate when a selection is made	SCAN/TRANSFER LED ON, detent is actuated	<ol style="list-style-type: none"> 1. Power supply 2. Wiring to mag. motor 3. Magazine motor 4. Mech control board
	SCAN/TRANSFER LED OFF	<ol style="list-style-type: none"> 1. Mech control board 2. Central control computer 3. Wiring from central control computer to mech control board
Magazine rotates continuously	SCAN/TRANSFER LED OFF	<ol style="list-style-type: none"> 1. Wiring to magazine motor 2. Mech control board

Table 5-2. Modular Troubleshooting Chart

Trouble	Symptom	Probable Cause
Magazine rotates continuously <i>(cont'd)</i>	SCAN/TRANSFER LED is ON, OPT. SW. INDEX LED is not flashing, and/or OPT. SW. HOME LED does not flash at Disc Number 99.	<ol style="list-style-type: none"> 1. Optical switch 2. Wiring to optical switch 3. Mech control board
	SCAN/TRANS LED ON and both optical switch LED's normal	Mech control board
Magazine stops at wrong disc	Stops at random CD anywhere in magazine	<ol style="list-style-type: none"> 1. Faulty optical switch 2. Wiring to optical switch 3. Heavy dirt buildup in optical switch
	Stops one or two discs before disc selected	<ol style="list-style-type: none"> 1. Optical switch adjustment 2. Magazine not full of CD's (out of balance) 3. Broken sprag lever guide
	Stops one or two discs after disc selected	<ol style="list-style-type: none"> 1. Faulty optical switch 2. Optical switch adjustment 3. Magazine not full of CD's (out of balance) 4. Broken sprag gear 5. Sprag linkage binding
	Stops one-half to one disc position off before or after disc selected	<ol style="list-style-type: none"> 1. Broken sprag gear 2. Broken sprag guide 3. Sprag linkage binding or needs adjustment

Table 5-2. Modular Troubleshooting Chart

Trouble	Symptom	Probable Cause
Disc does not transfer	SCAN/TRANSFER LED is ON	<ol style="list-style-type: none"> 1. Wiring to transfer motor 2. Mech control board 3. Transfer motor
	SCAN/TRANSFER LED is OFF	<ol style="list-style-type: none"> 1. Mech control board 2. Central control computer 3. Wiring from central control computer to mech control board
Transfer starts when power is applied and runs continuously	SCAN/TRANSFER LED is OFF	<ol style="list-style-type: none"> 1. Mech control board 2. Wiring to motor
	SCAN/TRANSFER LED is ON	<ol style="list-style-type: none"> 1. Mech control board 2. Open circuit at inner cam switch N.O. contact 3. Open circuit at inner cam switch Common 4. Outer cam switch N.O. shorted to Common
Transfer starts and runs continuously after selection is located	SCAN/TRANSFER LED comes ON when motor starts and stays ON	<ol style="list-style-type: none"> 1. Wiring to outer cam switch 2. Outer cam switch 3. Mech control board 4. Inner cam switch N.O. contact shorted to Common. 5. Open circuit in outer cam switch Common
No sound	Always muted	<ol style="list-style-type: none"> 1. Central control computer 2. Amplifier
Motor noise in speakers	Never muted	<ol style="list-style-type: none"> 1. Central control computer 2. Wiring between CCC and amplifier 3. Amplifier

Table 5-2. Modular Troubleshooting Chart

Trouble	Symptom	Probable Cause
All discs cancel without playing	Disc spins but will not play	<ol style="list-style-type: none"> 1. Short in cancel switch wiring 2. Cancel switch 3. Mech control board 4. CD player 5. Bad/upside down disc
	Disc will not spin	<ol style="list-style-type: none"> 1. Mech control board 2. CD player 3. Wiring between the CD player and the mech control
Some discs cancel without playing		<ol style="list-style-type: none"> 1. Defective discs (check disc conditions) 2. Mechanism control 3. CD player
Money counter or play counter fails to count	Fails to count	<ol style="list-style-type: none"> 1. Wiring to counter 2. Counter 3. Mech control board
Phonograph is always in SERVICE mode of operation	* SERVICE MODE * is always displayed after power up	<ol style="list-style-type: none"> 1. SERVICE switch 2. SERVICE switch wiring 3. Central control computer 4. Central control computer set for programming with the front door closed (the VOID SERVICE SWITCH option is ON)
Phonograph will not go into SERVICE mode	Display will not show * SERVICE MODE * or ERRORS EXIST when SERVICE switch is in SERVICE	<ol style="list-style-type: none"> 1. Central control computer 2. SERVICE switch wiring 3. SERVICE switch

Table 5-2. Modular Troubleshooting Chart

Trouble	Symptom	Probable Cause
Some CD's Skip		<ol style="list-style-type: none"> 1. Dirty discs or dirty lens on CD player (see <i>table 3-3</i> for lens cleaning procedure) 2. Defective discs (check disc conditions) 3. Mechanism control 4. CD player
All CD's skip		<ol style="list-style-type: none"> 1. Dirty lens on CD player (see <i>table 3-3</i> for lens cleaning procedure) 2. CD player 3. Mechanism control
No credit	No credit given by coins and dollar bills	Central control computer
	No credit given by coins but dollar bill gives credit	<ol style="list-style-type: none"> 1. Coin switch Common wiring 2. Central control computer
	One value of coin will not give credit	<ol style="list-style-type: none"> 1. Coin rejected 2. Wiring to coin switch 3. Coin switch 4. Central control computer
	Dollar bill will not give credit	<ol style="list-style-type: none"> 1. Bill acceptor 2. Wiring to bill acceptor 3. Central control computer
Wrong credit	Credit for amount deposited does not agree with price card setting	<ol style="list-style-type: none"> 1. One or more coins or bills did not register (<i>see No Credit</i>). 2. Central control computer programmed incorrectly. 3. Central control computer
System does not respond to keyboard	0 Credits on SELECTION REMAINING display	Insufficient credit

Table 5-2. Modular Troubleshooting Chart

Trouble	Symptom	Probable Cause
System does not respond to keyboard (<i>cont'd</i>)	Credits remain, but entire keyboard does not work	<ol style="list-style-type: none"> 1. Shorted keyboard switch 2. Central control computer 3. Short in keyboard wiring
	Credits remain, but certain keys do not work	<ol style="list-style-type: none"> 1. Wiring from keyboard to title rack/keyboard interface 2. Keyboard 3. Title rack/keyboard interface 4. Central control computer
Digital display does not work	Display lights, but shows wrong information	<ol style="list-style-type: none"> 1. Digital display 2. Central control computer
Title pages do not operate normally	Title pages do not move at all or movement is very slight	<ol style="list-style-type: none"> 1. Mechanical jam in the mechanism—Try to rotate the motor by hand—Disassemble to locate the jam. 2. The motor will not run—faulty motor—test for voltage at the motor—Try rotating the motor by hand. Remove the motor and test it. 3. The switches are not adjusted properly—Adjust according to the procedure in <i>Section 6</i>. 4. The title page harness is not plugged in.
	Two pages on a side try to turn at the same time	The metal fingers on the back of the top of the page are bent because the pages were forced. Remove the racks from the back side of the assembly—Inspect the metal fingers and straighten any bent fingers.

Table 5-2. Modular Troubleshooting Chart

Trouble	Symptom	Probable Cause
Title pages do not operate normally (<i>cont'd</i>)	Pages continue to flip past the next page	<ol style="list-style-type: none"> 1. Index switch on the title display is defective or out of adjustment. 2. Harness between title display and P6 of the title rack/keyboard interface. 3. Harness between P3 of the title rack/keyboard interface and P5 or P15 of the central control computer. 4. Defective title rack/keyboard interface module. 5. Defective central control computer.
	Cannot get the desired page	<ol style="list-style-type: none"> 1. PAGE IN/OUT limits are not set correctly—<i>See Section 2.</i> 2. Limit switch on the title display is defective or out of adjustment. 3. Harness between the title display and J5 of the digital display. 4. Harness between J3 of the digital display and P5 or P15 of the central control computer. 5. Defective digital display module. 6. Defective central control computer.

Table 5-2. Modular Troubleshooting Chart

Trouble	Symptom	Probable Cause
Title pages do not operate normally (<i>cont'd</i>)	Pages do not operate from keyboard OUT/IN switches or from the titles OUT/IN switch	<ol style="list-style-type: none"> 1. Defective title motor. 2. Defective digital display module. 3. Defective central control computer. 4. Harness between title display and P6 of the title rack/keyboard interface. 5. Harness between P3 of the title rack/keyboard interface and P5 or P15 of the central control computer. 6. Defective keyboard. 7. Harness between J1 of the keyboard and J4 of the digital display.
	Pages do not operate from the keyboard OUT/IN switches, but do operate from the titles OUT/IN switch	Defective keyboard
	Pages do not operate from the titles OUT/IN switch, but do operate from the keyboard OUT/IN switches	<ol style="list-style-type: none"> 1. Defective titles OUT/IN switch 2. Harness between titles OUT/IN switch and J2 of the keyboard. 3. Defective keyboard.
Miscellaneous problems	Any malfunction not described above	<ol style="list-style-type: none"> 1. Main power supply 2. Central control computer

SOUND SYSTEM QUICK CHECK

Rowe solid state sound systems are service designed for fast, easy repair. The following check list will enable you to locate troubles with basic tools. Refer to figures 5-1 and 5-4 as needed.



WARNING:

Do not plug in or unplug circuit boards with power ON. Checks should be made with the changer in the disc playing position. Perform all service checks in the order listed.

No Sound — Both Channels

POWER - SECOND LEVEL

1. Check that the amplifier is plugged-in and is receiving power from the power supply.
2. Disconnect the mute plug.
3. Press the circuit breaker reset pushbutton on the amplifier chassis to make sure that it is not tripped. The amplifier should cause an audible "thump" in the speakers when its power is turned ON.

VOLUME CONTROL

Disconnect the volume control plug from the amplifier chassis and short out Pin 3 (Common) to Pins 1, 2 and 4, 5. Full volume indicates an open volume control or line. If full volume at all times is the problem and disconnecting the volume control plug does not kill the sound, replace the preamp board.

No Sound, Low Sound Or Distorted Sound Right Or Left Channel Only

EXTENSION SPEAKERS

Check the OVERLOAD indicators (see figure 1-6), then disconnect the extension speakers from the transformer package receptacle (figure 1-7 also) and look at the OVERLOAD indicators again. If either or both OVERLOAD indicators were ON, but are now OFF, the overload is in the extension speakers.

Check that the phonograph is not overloaded by performing the following five steps:

1. Make sure that the phonograph and extension speakers are connected to the proper speaker taps.
2. On the amplifier, set all seven RIGHT CHANNEL and all seven LEFT CHANNEL graphic equalizer controls fully counter-clockwise.
3. Set the volume control fully clockwise (maximum volume) and make a selection.
4. While the music is playing, an acceptable load will allow the OVERLOAD INDICATORS(S) to be off or occasionally flicker in a random manner. If the OVERLOAD INDICATOR(S) are always lit or flicker continuously, the amplifier is overloaded and you must perform Step 5.

5. Do this step only if the OVERLOAD INDICATOR(S) came on as described in the previous step. Find the source of the overload (shorted speaker wires, too many speakers connected, or speaker power taps too high). After you fix the short, disconnect a few speakers, or lower the speaker power tap selection; repeat *Step 4*.

OUTPUT DEVICES

Visually inspect the driver board for blown fuses. If a fuse is blown, replace the associated output device. The two devices used in each channel are not interchangeable. Check the part number on the case and install an identical or equivalent replacement. Before mounting the device onto the heat sink, be sure that the heat sink surface is flat and no burrs are around the mounting holes to cause a short. Be sure that one, and only one, mica insulator is between the device and the heat sink and heat transfer compound (*Rowe Specification 0-00053-00*) is on both sides of insulator.

FILTER CAPACITORS

Check for plus and minus 40 VDC in the amplifier power supply. Connect the negative meter lead to ground and check the voltage at the terminals of the large electrolytic filter capacitors located on the amplifier chassis next to the power transformer. When taking readings on the capacitor with the outer shell isolated from chassis to one of the shell tabs, check that the voltage on each capacitor terminal is the same. A lowered voltage at one of the capacitor pins indicates that the capacitor may be defective and should be replaced, or that the bridge rectifier is defective. Another indication of defective filter capacitors is excessive hum in the sound output.

PREAMP OUTPUT

Short all five of the volume control pins located on amp. Press your finger against Pins 1 or 3 (outside pins) labeled PHONO CARTRIDGE INPUT, and check for approximately 1 VAC at preamp output (Pins 3 or 5 of 13 pin connector to chassis Common). Replace the preamp board if voltage is not present. If voltage is present check the center pin of the output driver board for approximately 16 VAC. If voltage is not present, make sure your finger is pressed against the same outside pin with respect to the channel that is being checked with the voltmeter.

DRIVER BOARDS

If one driver board is defective, switch the input to "Mono" and use the good channel temporarily.

Constant High Volume — Cannot Adjust

VOLUME CONTROL

Disconnect volume control plug from amplifier chassis. No sound indicates a short in the volume control line or the volume control connector is plugged in backwards. White/violet wire should be closest to heatsink.

PREAMP

If full volume is heard with control plug disconnected, replace the preamplifier board.

Excessive Hum

OPEN SHIELD

Be sure that shield or wires are not broken between CD player and the amplifier input plug.

FILTER CAPACITORS

Check filter capacitor, parallel an extra 500 Mfd. 50V capacitor in chassis. If hum drops; replace the capacitor. If external inputs are used, the equipment driving those inputs must not be tied to Earth Ground.

This page intentionally left blank.

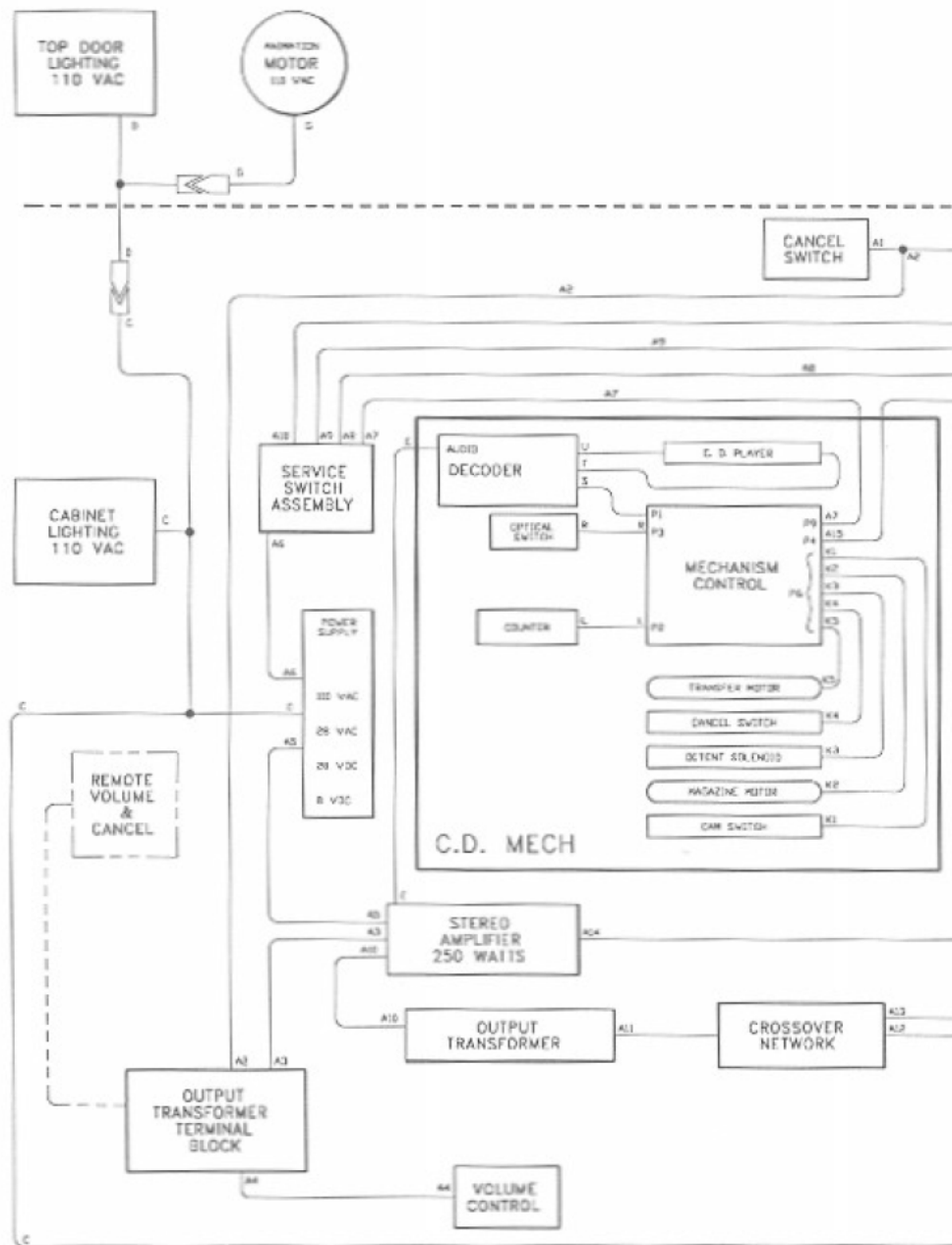

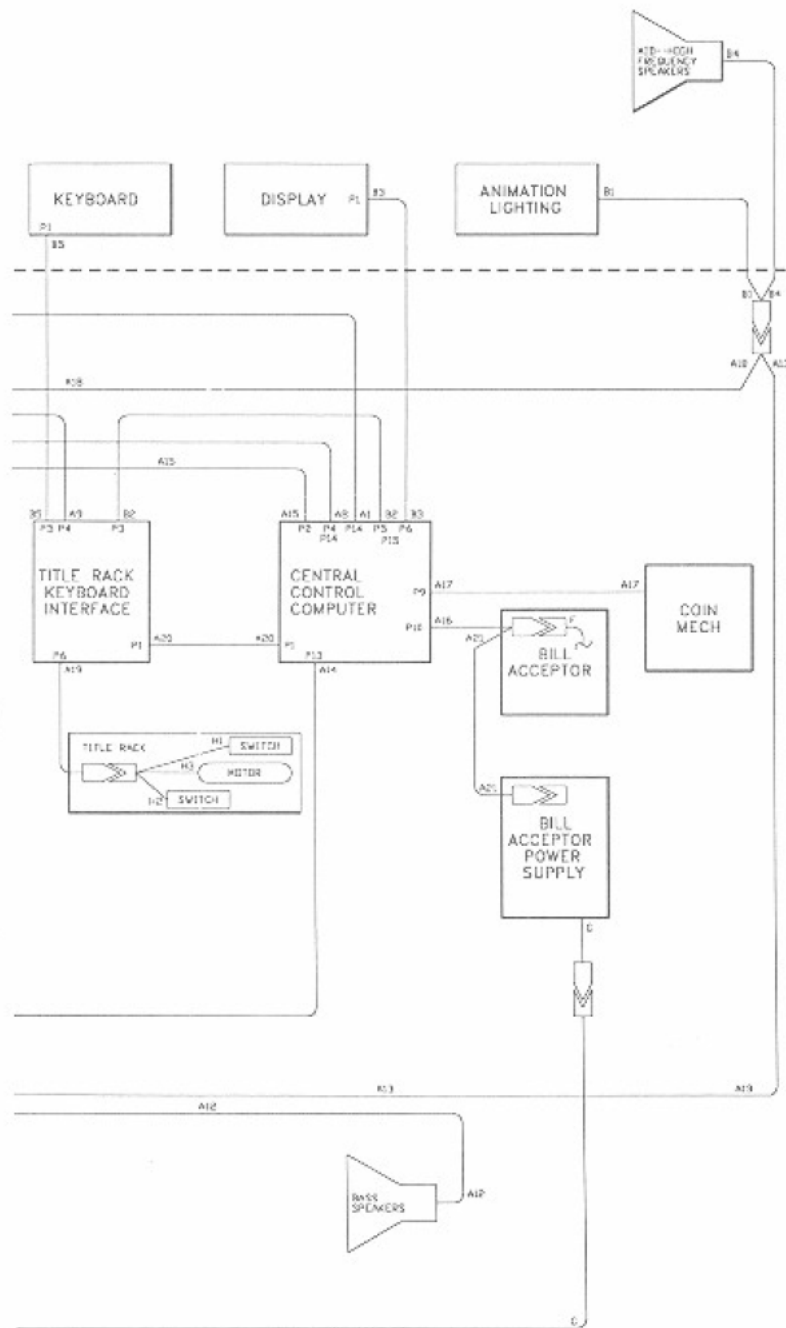

- A → HARNESS & SWITCH ASSY 61060901**
1. Cancel To Computer
 2. Cancel Line To Terminal Block
 3. Remote Volume & Volume Control From Amplifier
 4. Volume Control
 5. 110 VAC To Amplifier
 6. Low Voltage Power To Switch
 7. 28 VAC To CD Player
 8. Low Voltage Power To Computer
 9. Page Control To Title Rack / Keyboard Interface
 10. Amplifier Output (Audio)
 11. Audio Output To Crossover
 12. Audio Output To Bass Speakers
 13. Audio Output To Mid-High Frequency Speakers
 14. Mute
 15. Signal & VDC Power To CD Player
 16. Signal To Bill Acceptor
 17. Signal-Coin Mechanism
 18. 28 VAC Power To Animation Lighting
 19. Signal And Power To Title Rack
 20. VDC Power To The Title Rack / Keyboard Interface
 21. VDC Power To Bill Acceptor
- B → HARNESS ASSY - DISPLAY 40855101**
1. 28 VAC Power To Animation Lighting
 2. Signal And VDC Power To Title Rack Keyboard Interface
 3. Signal And VDC Power To Display
 4. Audio Input To Mid-High Frequency Speakers
 5. Signal To Keyboard
- C → HARNESS ASSY - 110 VAC 60/50 HZ . . . 40854301/02**
- D → HARNESS ASSY - TOP DOOR LIGHTING . . 40855201**
- E → CABLE ASSEMBLY - AUDIO 30934203**
- F → HARNESS ASSEMBLY - CBA-2 35127401**
- G → MOTOR & HARNESS ASSY 40824302**
- H → HARNESS ASSY - INTERCONNECT 30938501**
1. Switch - Signal To Title Rack / Keyboard Interface
 2. Switch - Signal To Title Rack / Keyboard Interface
 3. Motor Power From Title Rack / Keyboard Interface
- K → HARNESS ASSY - CD MECH. 40830002**
1. Cam Switch To Mech. Control
 2. Magazine Motor To Mech. Control
 3. Detent Solenoid To Mech. Control
 4. Cancel Switch To Mech. Control
 5. Transfer Motor To Mech. Control
- L → COUNTER & PLUG ASSEMBLY 30933301**
- R → OPTICAL SWITCH ASSEMBLY. 30906801**
- S → HARNESS DECODER - RIBBON CABLE 21959501**
- T → HARNESS ASSEMBLY - LASER (14 WIRE) 30955601**
- U → HARNESS ASSY - PLAYER MOTOR (4 WIRE) 30955501**

Figure 5-4. CD-100C Harness Diagram

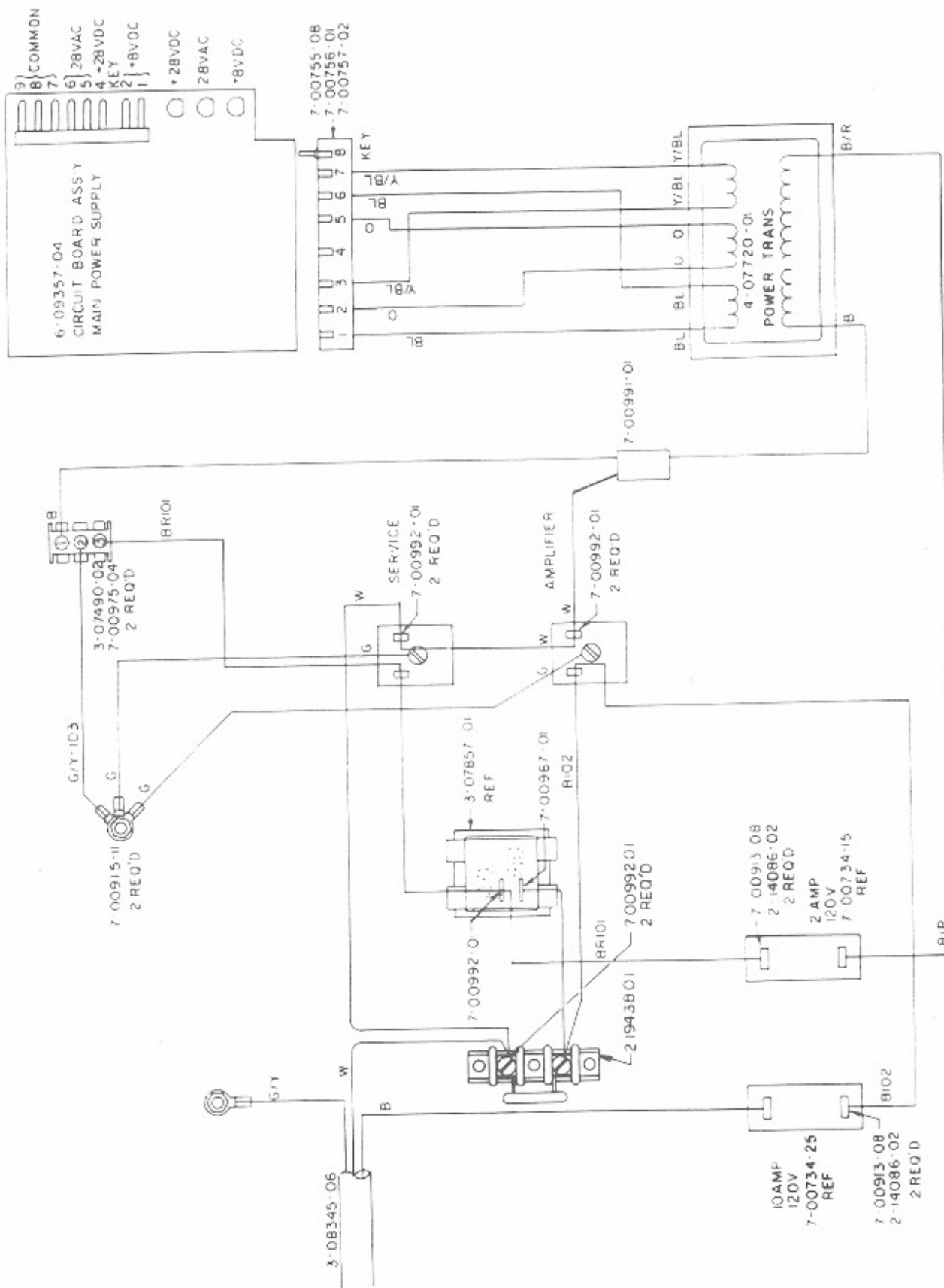

For Equivalent Engineering Drawing See 40770609-Q1 A

Figure 5-5A. Main Power Supply Wiring Diagram - Domestic

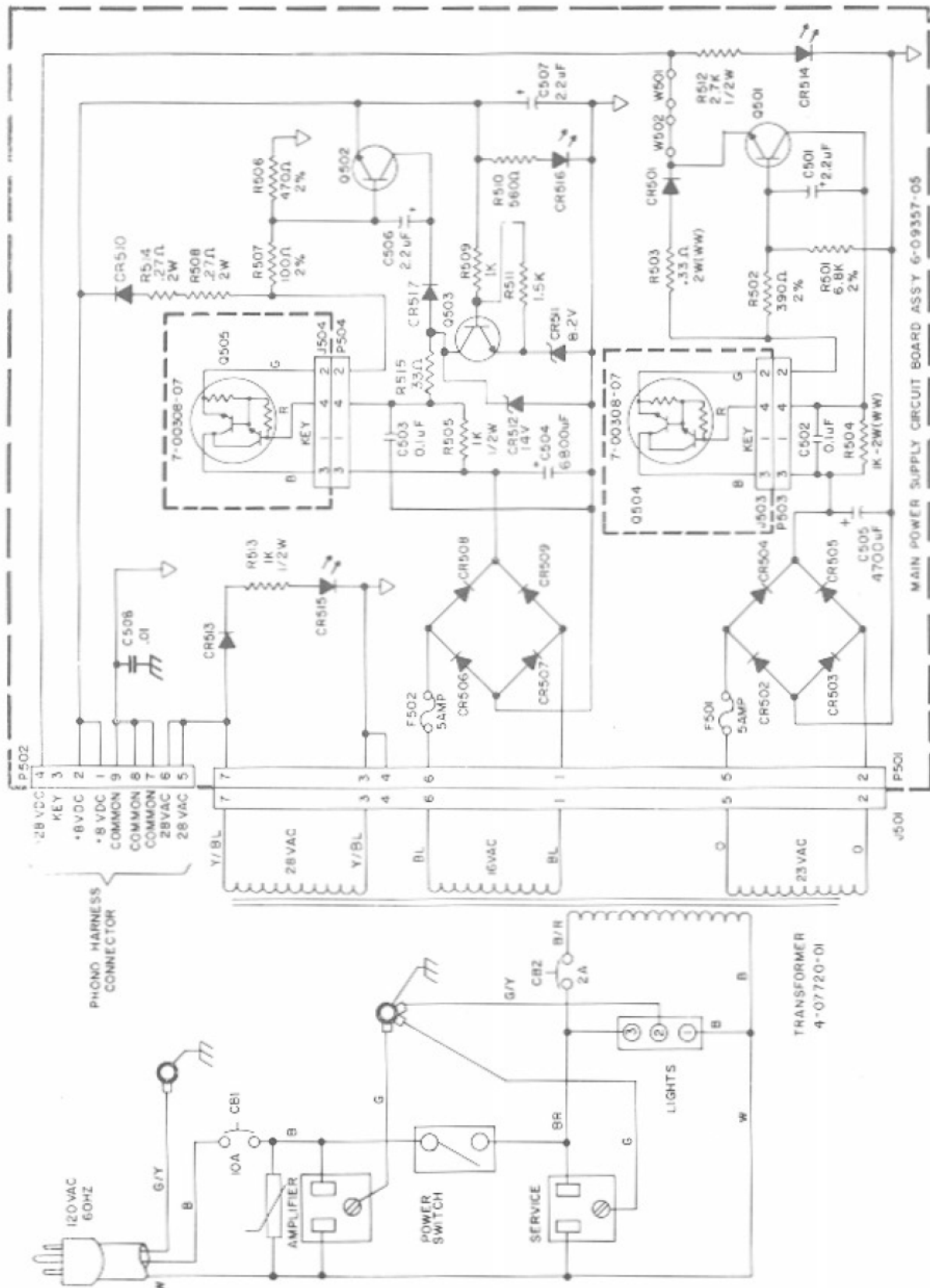

SCHEMATIC DIAGRAM-MAIN POWER SUPPLY
For Equivalent Engineering Drawing See 40770609-02 E

Figure 5-5B. Main Power Supply Schematic - Domestic

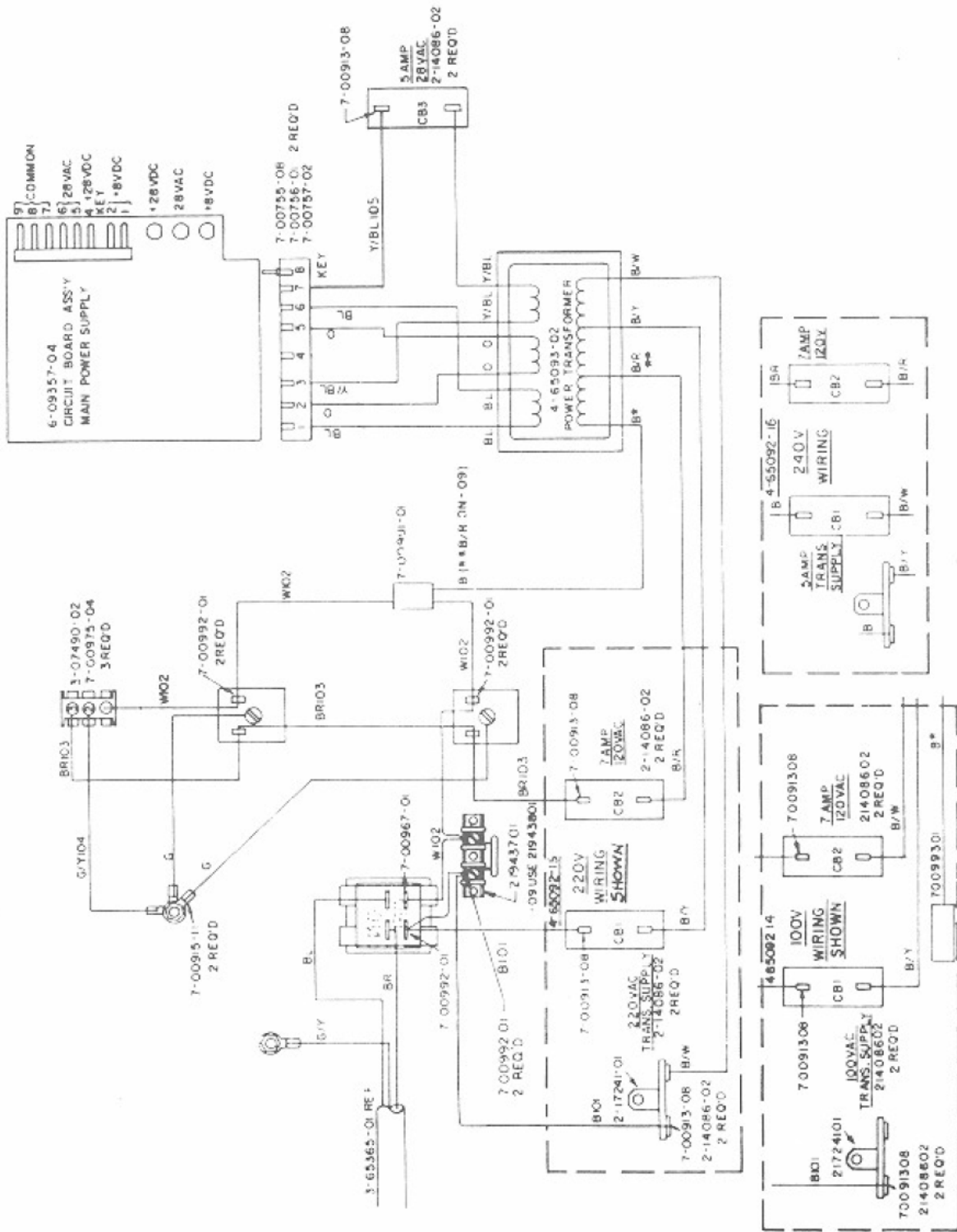

For Equivalent Engineering Drawing See 46509214/15/16-Q1 B

Figure 5-6A. Main Power Supply Wiring Diagram - Export

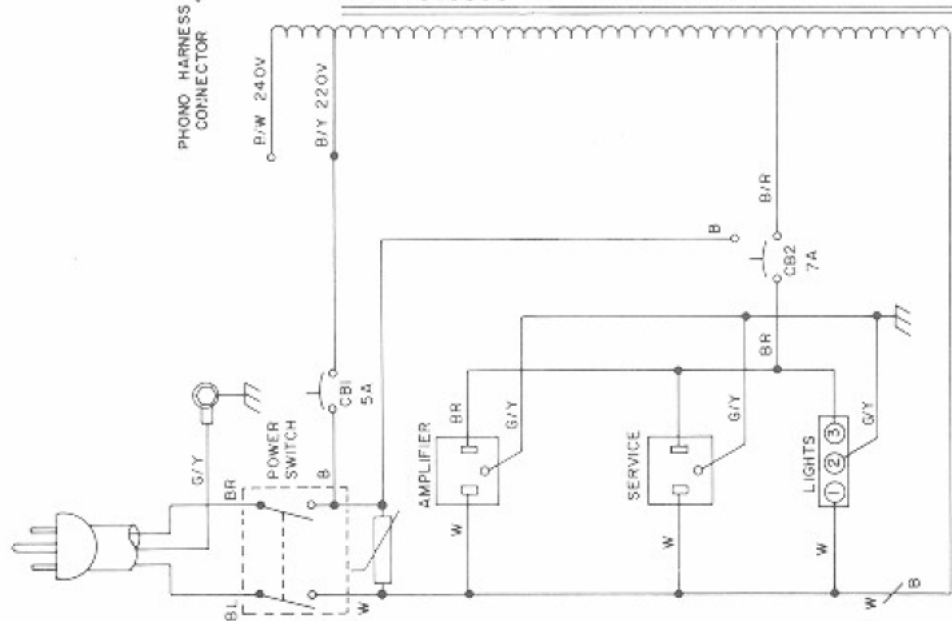

1. 220VAC SCHEMATIC DIAGRAM IS SHOWN.
 2. 240VAC IS SAME EXCEPT CBI IS WIRED TO TRANSFORMER BLACK/WHITE LEAD.
 3. FOR 120VAC CBI IS WIRED TO TRANSFORMER BLACK/RED LEAD, AND CB2 IS WIRED TO BLACK WIRE FROM POWER SWITCH.
 4. FOR 100VAC CB2 IS WIRED TO TRANSFORMER B/W LEAD, AND TRANSFORMER B/R IS SPliced TO WHITE TRANSFORMER. B IS NOT CONNECTED ALSO. CBI AND CB2 ARE BOTH 7A.
- 465092 14 IS 100VAC
 465092 15 IS 230VAC
 465092 16 IS 240VAC

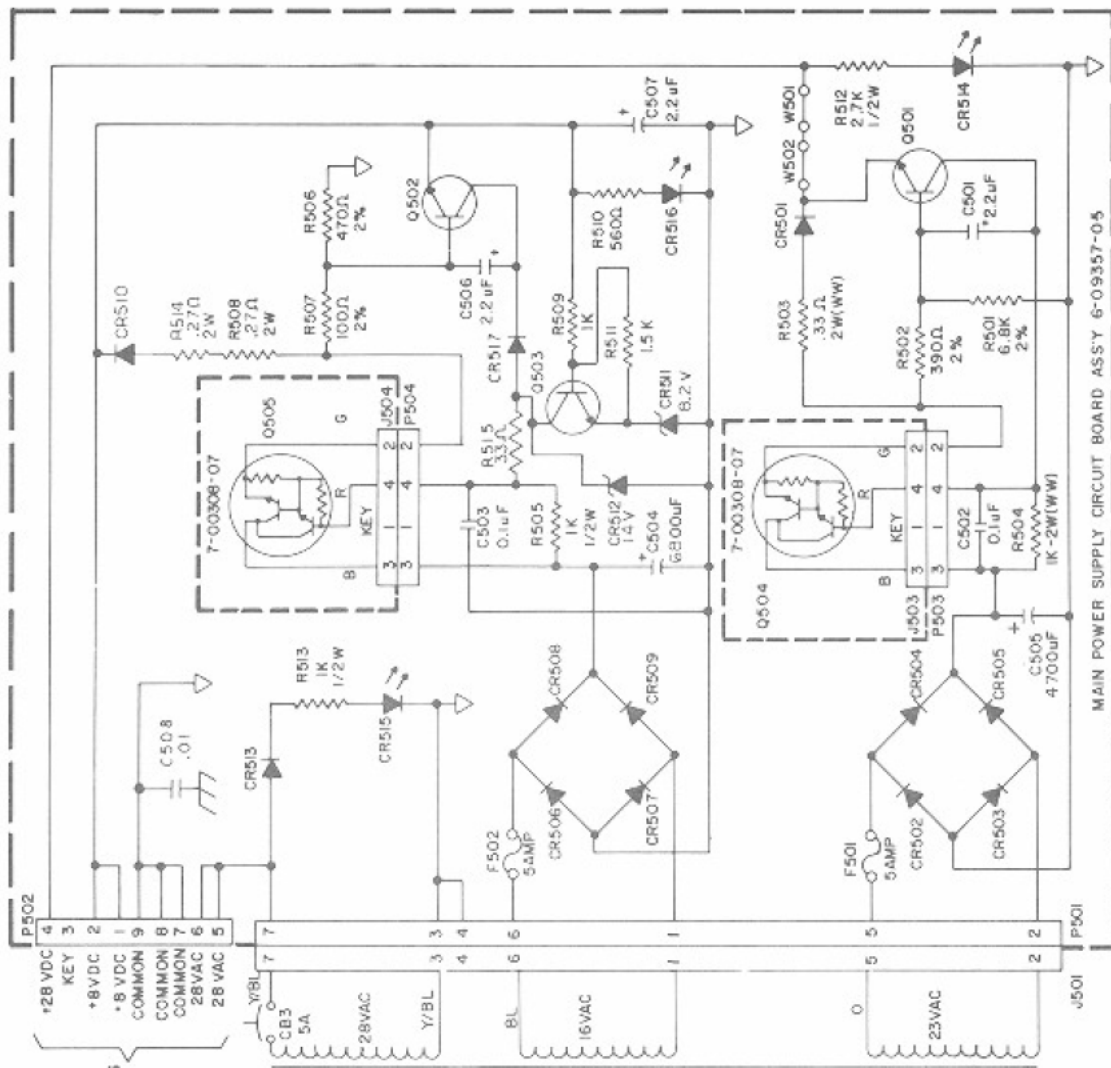

SCHEMATIC DIAGRAM - MAIN POWER SUPPLY
 For Equivalent Engineering Drawing See 46509214/15/16-Q2 E

Figure 5-6B. Main Power Supply Schematic - Export

**COMPONENTS LIST FOR
MAIN POWER SUPPLY CIRCUIT BOARD 60935705**

C501	CAPACITOR - ELECTROLYTIC	2.2 μ F @ 50V	70023805
C502	CAPACITOR - MONOLYTHIC CERAMIC	0.1 μ F @ 50V	70028511
C503	CAPACITOR - MONOLYTHIC CERAMIC	0.1 μ F @ 50V	70028511
C504	CAPACITOR - ELECTROLYTIC	6800 μ F @ 35V	70023601
C505	CAPACITOR - ELECTROLYTIC	4700 μ F @ 50V	70023604
C506	CAPACITOR - ELECTROLYTIC	2.2 μ F @ 50V	70023805
C507	CAPACITOR - ELECTROLYTIC	2.2 μ F @ 50V	70023805
C508	CAPACITOR - MONOLYTHIC CERAMIC	0.01 μ F @ 1000V	70022508
CR502	DIODE - SILICON		70035004
CR502	DIODE - SILICON		70035004
CR503	DIODE - SILICON		70035004
CR504	DIODE - SILICON		70035004
CR505	DIODE - SILICON		70035004
CR506	DIODE - SILICON		70035004
CR507	DIODE - SILICON		70035004
CR508	DIODE - SILICON		70035004
CR509	DIODE - SILICON		70035004
CR510	DIODE - SILICON		70035004
CR511	DIODE - ZENER	8.2 V 5%	70035528
CR512	DIODE - ZENER	14 V 5%	70035529
CR513	DIODE - SILICON		70035004
CR514	DIODE - LIGHT EMITTING		70035303
CR515	DIODE - LIGHT EMITTING		70035303
CR516	DIODE - LIGHT EMITTING		70035303
CR517	DIODE - SILICON		70035004
F501	FUSE - 5 AMP		70072106
F502	FUSE - 5 AMP		70072106
P501	POLARIZING WAFER ASSEMBLY		70075007
P502	POLARIZING WAFER - 90°		70076009
P503	POLARIZING WAFER ASSEMBLY		70075003
P504	POLARIZING WAFER ASSEMBLY		70075003

Q501	TRANSISTOR - SILICON	(NPN)	70033005
Q502	TRANSISTOR - SILICON	(NPN)	70033005
Q503	TRANSISTOR - SILICON	(NPN)	70033008
R501	RESISTOR - CARBON (1/4W, 2%)	6.8K Ω	79902682
R502	RESISTOR - CARBON (1/4W, 2%)	390 Ω	79902391
R503	RESISTOR - WIRE WOUND (2W, 5%)	0.33 Ω	79920338
R504	RESISTOR - WIRE WOUND (1/2W, 10%)	1K Ω	79920102
R505	RESISTOR - CARBON (1/2W, 10%)	1K Ω	70010619
R506	RESISTOR - CARBON (1/4W, 2%)	470 Ω	79902471
R507	RESISTOR - CARBON (1/4W, 2%)	100 Ω	79902101
R508	RESISTOR - WIRE WOUND (2W, 10%)	0.27 Ω	79920278
R509	RESISTOR - CARBON (1/4W, 5%)	1K Ω	79901102
R510	RESISTOR - CARBON (1/4W, 5%)	560 Ω	79901561
R511	RESISTOR - CARBON (1/4W, 5%)	1.5K Ω	79901152
R512	RESISTOR - CARBON (1/2W, 5%)	2.7K Ω	70012007
R513	RESISTOR - CARBON (1/2W, 10%)	1K Ω	70010619
R514	RESISTOR - WIRE WOUND (2W, 5%)	0.27 Ω	79920278
R515	RESISTOR - CARBON (1/4W, 5%)	33 Ω	79901330
W501	WIRE - BARE		00503200
W502	WIRE - BARE		00503200

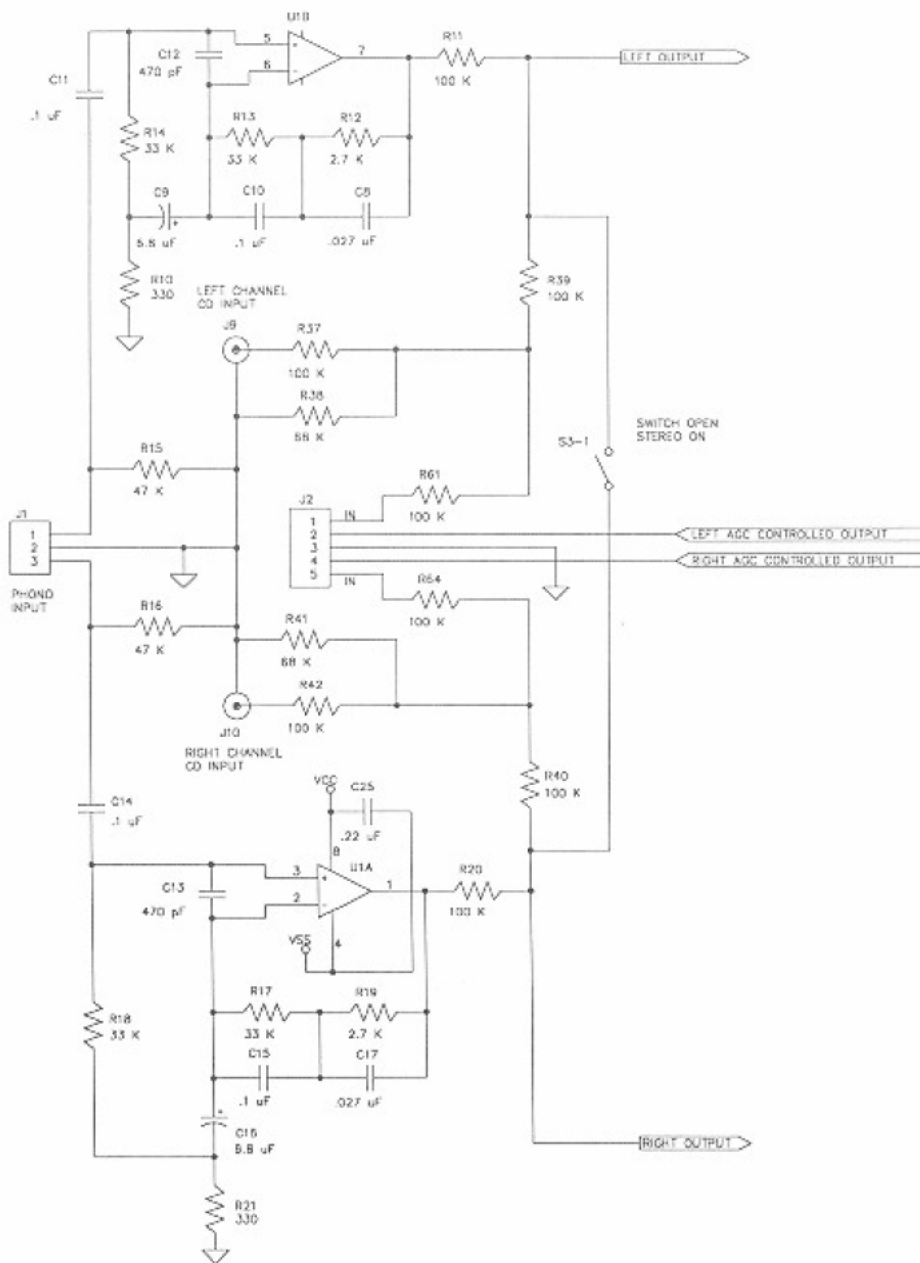

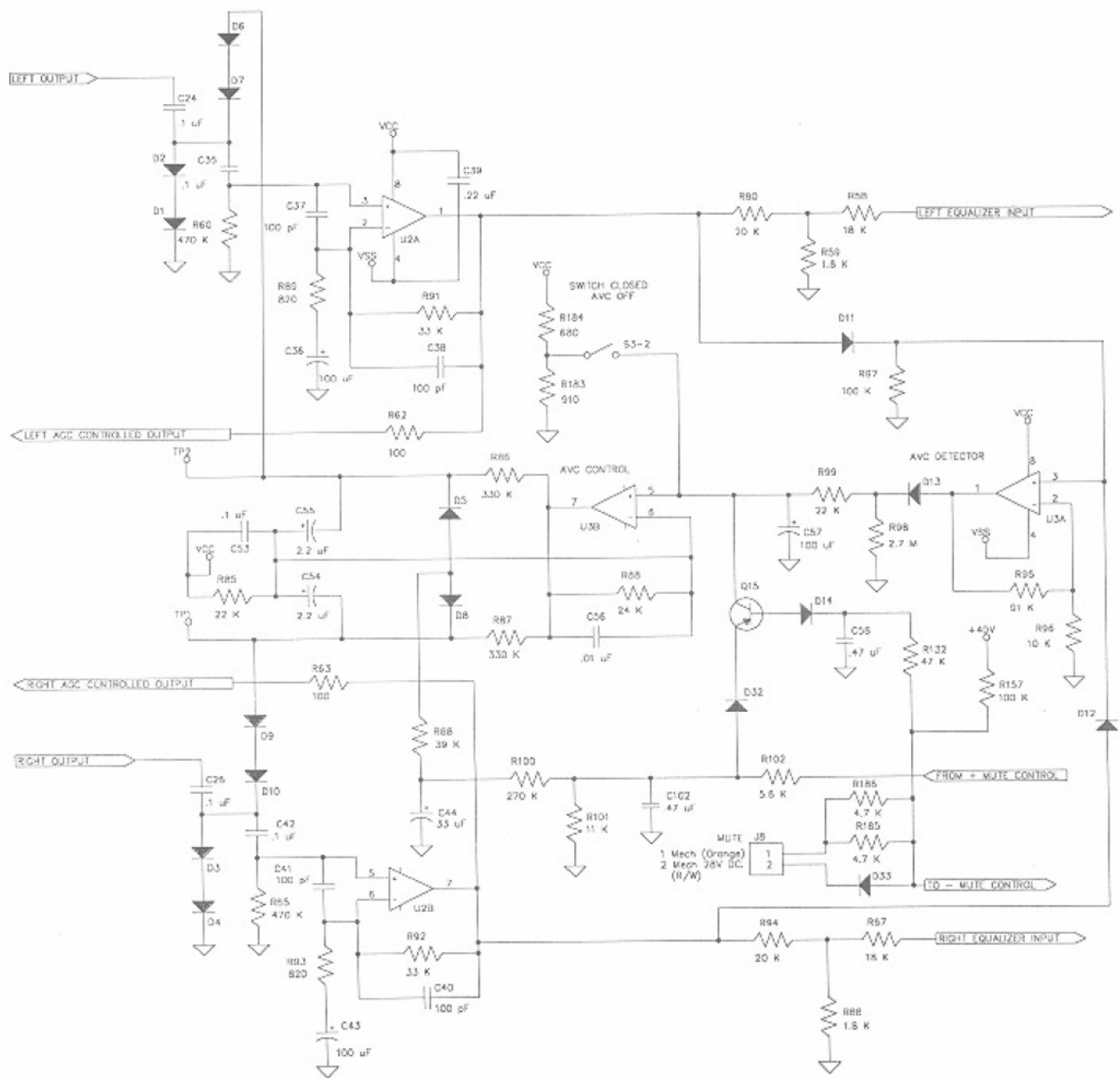

For Equivalent Engineering Drawing See 61023702-Q2 C

Figure 5-7A. Schematic Diagram - Stereo Preamp Assembly, Sheet 1

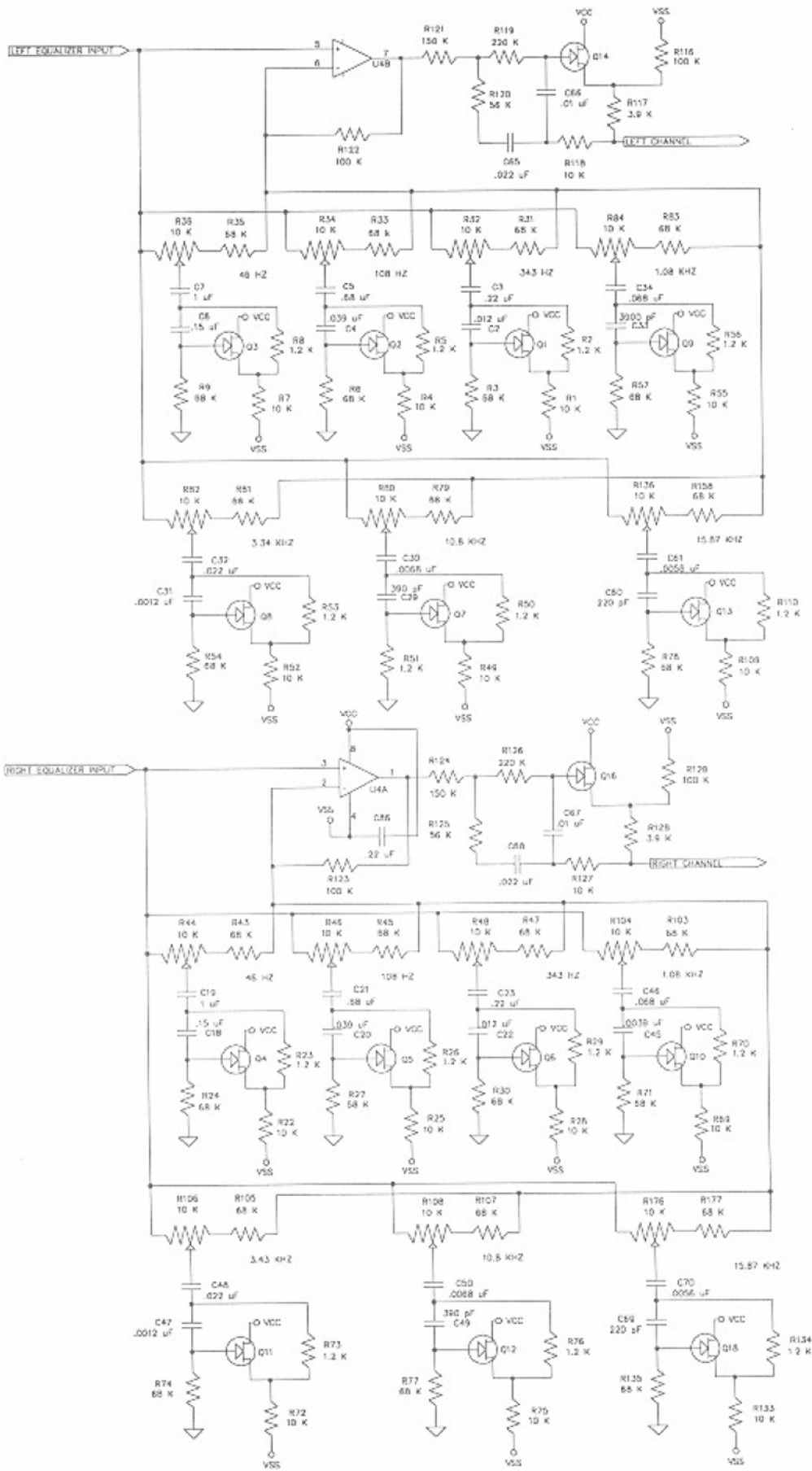

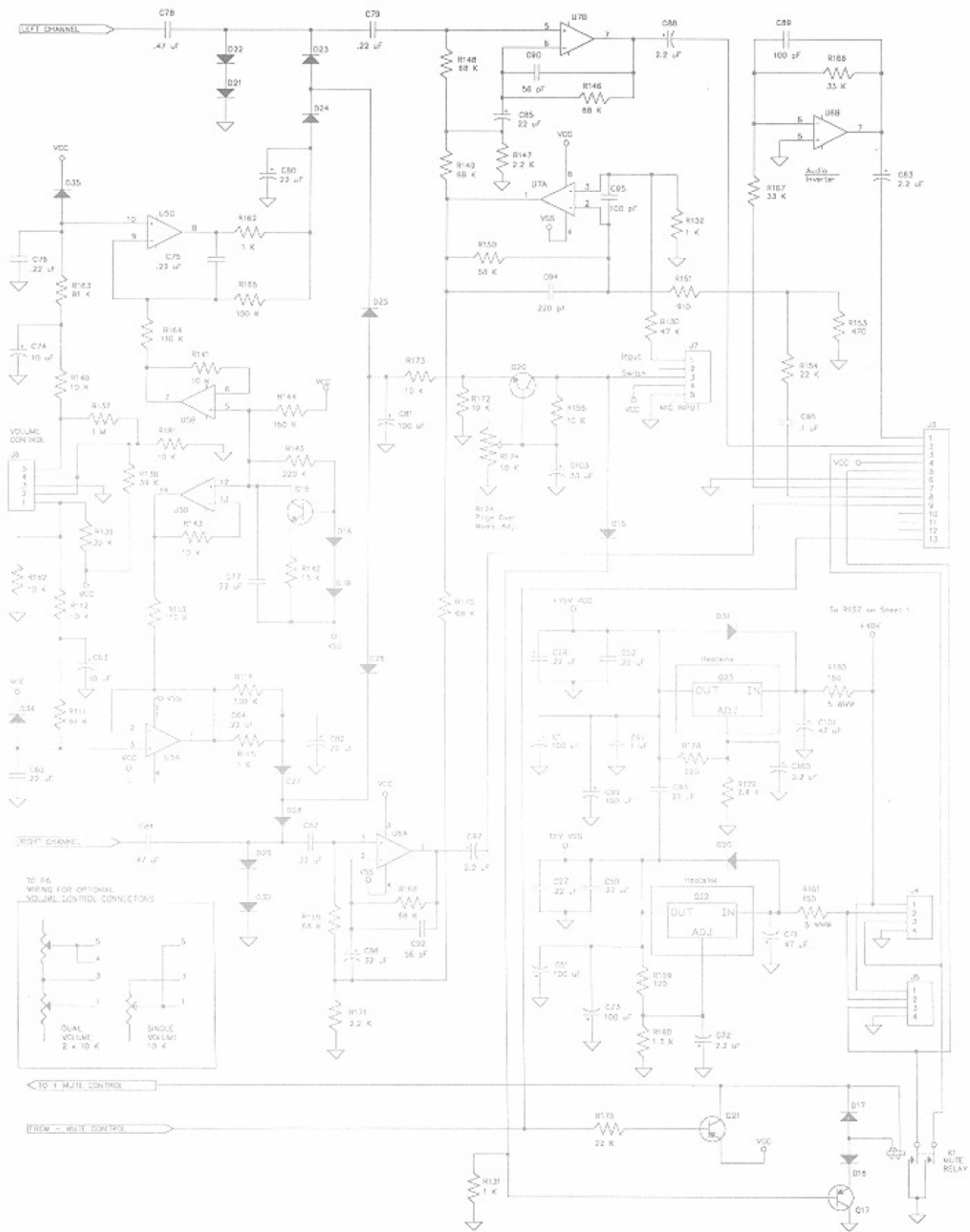

For Equivalent Engineering Drawing See 61023702-Q2 C

Figure 5-7A. Schematic Diagram - Stereo Preamp Assembly, Sheet 2

COMPONENT LIST FOR PREAMPLIFIER BOARD (61023702-D)

C1	CAPACITOR - ELECTROLYTIC	100 μ F	70023814
C2	CAPACITOR - MONO CERAMIC	.012 μ F	70028638
C3	CAPACITOR - MONO CERAMIC	.22 μ F	70028523
C4	CAPACITOR - MONO CERAMIC	.039 μ F	70028644
C5	CAPACITOR - MONO CERAMIC	.68 μ F	70028522
C6	CAPACITOR - MONO CERAMIC	.15 μ F	70028512
C7	CAPACITOR - MONO CERAMIC	1 μ F	70028521
C8	CAPACITOR - MONO CERAMIC	.027 μ F	70028642
C9	CAPACITOR - ELECTROLYTIC	6.8 μ F	70023807
C10	CAPACITOR - MONO CERAMIC	.1 μ F	70028649
C11	CAPACITOR - MONO CERAMIC	.1 μ F	70028649
C12	CAPACITOR - MONO CERAMIC	470 PF	70028612
C13	CAPACITOR - MONO CERAMIC	470 PF	70028612
C14	CAPACITOR - MONO CERAMIC	.1 μ F	70028649
C15	CAPACITOR - MONO CERAMIC	.1 μ F	70028649
C16	CAPACITOR - ELECTROLYTIC	6.8 μ F	70023807
C17	CAPACITOR - MONO CERAMIC	.027 μ F	70028642
C18	CAPACITOR - MONO CERAMIC	.15 μ F	70028512
C19	CAPACITOR - MONO CERAMIC	1 μ F	70028521
C20	CAPACITOR - MONO CERAMIC	.039 μ F	70028644
C21	CAPACITOR - MONO CERAMIC	.68 μ F	70028522
C22	CAPACITOR - MONO CERAMIC	.012 μ F	70028638
C23	CAPACITOR - MONO CERAMIC	.22 μ F	70028523
C24	CAPACITOR - MONO CERAMIC	.1 μ F	70028649
C25	CAPACITOR - MONO CERAMIC	.22 μ F	70028523
C26	CAPACITOR - MONO CERAMIC	.1 μ F	70028649
C27	CAPACITOR - MONO CERAMIC	.22 μ F	70028523
C28	CAPACITOR - MONO CERAMIC	.22 μ F	70028523
C29	CAPACITOR - MONO CERAMIC	390 PF	70028611
C30	CAPACITOR - MONO CERAMIC	.0068 μ F	70028633
C31	CAPACITOR - MONO CERAMIC	.0012 μ F	70028620
C32	CAPACITOR - MONO CERAMIC	.022 μ F	70028641
C33	CAPACITOR - MONO CERAMIC	.0039 μ F	70028629
C34	CAPACITOR - MONO CERAMIC	.068 μ F	70028647
C35	CAPACITOR - MONO CERAMIC	.1 μ F	70028649
C36	CAPACITOR - ELECTROLYTIC	100 μ F	70023814
C37	CAPACITOR - MONO CERAMIC	100 PF	70028601
C38	CAPACITOR - MONO CERAMIC	100 PF	70028601
C39	CAPACITOR - MONO CERAMIC	.22 μ F	70028523
C40	CAPACITOR - MONO CERAMIC	100 PF	70028601
C41	CAPACITOR - MONO CERAMIC	100 PF	70028601
C42	CAPACITOR - MONO CERAMIC	.1 μ F	70028649
C43	CAPACITOR - ELECTROLYTIC	100 μ F	70023814
C44	CAPACITOR - ELECTROLYTIC	33 μ F	70023811
C45	CAPACITOR - MONO CERAMIC	.0039 μ F	70028629
C46	CAPACITOR - MONO CERAMIC	.068 μ F	70028647
C47	CAPACITOR - MONO CERAMIC	.0012 μ F	70028620
C48	CAPACITOR - MONO CERAMIC	.022 μ F	70028641
C49	CAPACITOR - MONO CERAMIC	390 PF	70028611
C50	CAPACITOR - MONO CERAMIC	.0068 μ F	70028633
C51	CAPACITOR - ELECTROLYTIC	100 μ F	70023814
C52	CAPACITOR - MONO CERAMIC	.22 μ F	70028523
C53	CAPACITOR - MONO CERAMIC	.1 μ F	70028649
C54	CAPACITOR - ELECTROLYTIC	2.2 μ F	70023805
C55	CAPACITOR - ELECTROLYTIC	2.2 μ F	70023805

C56	CAPACITOR - MONO CERAMIC	.01 μ F	70028636
C57	CAPACITOR - ELECTROLYTIC	100 μ F	70023814
C58	CAPACITOR - MONO CERAMIC	.47 μ F	70028516
C59	CAPACITOR - MONO CERAMIC	.22 μ F	70028523
C60	CAPACITOR - MONO CERAMIC	220 PF	70028606
C61	CAPACITOR - MONO CERAMIC	.0056 μ F	70028632
C62	CAPACITOR - MONO CERAMIC	.22 μ F	70028523
C63	CAPACITOR - ELECTROLYTIC	10 μ F	70023808
C64	CAPACITOR - MONO CERAMIC	.22 μ F	70028523
C65	CAPACITOR - MONO CERAMIC	.022 μ F	70028641
C66	CAPACITOR - MONO CERAMIC	.01 μ F	70028636
C67	CAPACITOR - MONO CERAMIC	.01 μ F	70028636
C68	CAPACITOR - MONO CERAMIC	.022 μ F	70028641
C69	CAPACITOR - MONO CERAMIC	220 PF	70028606
C70	CAPACITOR - MONO CERAMIC	.0056 μ F	70028632
C71	CAPACITOR - ELECTROLYTIC	47 μ F	70023812
C72	CAPACITOR - ELECTROLYTIC	2.2 μ F	70023805
C73	CAPACITOR - ELECTROLYTIC	100 μ F	70023814
C74	CAPACITOR - ELECTROLYTIC	10 μ F	70023808
C75	CAPACITOR - MONO CERAMIC	.22 μ F	70028523
C76	CAPACITOR - MONO CERAMIC	.22 μ F	70028523
C77	CAPACITOR - MONO CERAMIC	.22 μ F	70028523
C78	CAPACITOR - MONO CERAMIC	.47 μ F	70028516
C79	CAPACITOR - MONO CERAMIC	.22 μ F	70028523
C80	CAPACITOR - ELECTROLYTIC	22 μ F	70023810
C81	CAPACITOR - ELECTROLYTIC	100 μ F	70023814
C82	CAPACITOR - ELECTROLYTIC	22 μ F	70023810
C83	CAPACITOR - ELECTROLYTIC	2.2 μ F	70023805
C84	CAPACITOR - MONO CERAMIC	.47 μ F	70028516
C85	CAPACITOR - ELECTROLYTIC	22 μ F	70023810
C86	CAPACITOR - MONO CERAMIC	.22 μ F	70028523
C87	CAPACITOR - MONO CERAMIC	.22 μ F	70028523
C88	CAPACITOR - ELECTROLYTIC	2.2 μ F	70023805
C89	CAPACITOR - MONO CERAMIC	100 PF	70028601
C90	CAPACITOR - MONO CERAMIC	56 PF	70028710
C91	CAPACITOR - MONO CERAMIC	.1 μ F	70028649
C92	CAPACITOR - MONO CERAMIC	56 PF	70028710
C93	CAPACITOR - MONO CERAMIC	.22 μ F	70028523
C94	CAPACITOR - MONO CERAMIC	220 PF	70028606
C95	CAPACITOR - MONO CERAMIC	100 PF	70028601
C96	CAPACITOR - ELECTROLYTIC	22 μ F	70023810
C97	CAPACITOR - ELECTROLYTIC	2.2 μ F	70023805
C98	CAPACITOR - MONO CERAMIC	.1 μ F	70028649
C99	CAPACITOR - ELECTROLYTIC	100 μ F	70023814
C100	CAPACITOR - ELECTROLYTIC	2.2 μ F	70023805
C101	CAPACITOR - ELECTROLYTIC	47 μ F	70023812
C102	CAPACITOR - MONO CERAMIC	.47 μ F	70028516
C103	CAPACITOR - ELECTROLYTIC	33 μ F	70023811
D1	DIODE - SILICON	1N4148	70035012
D2	DIODE - SILICON	1N4148	70035012
D3	DIODE - SILICON	1N4148	70035012
D4	DIODE - SILICON	1N4148	70035012
D5	DIODE - SILICON	1N4148	70035012
D6	DIODE - SILICON	1N4148	70035012
D7	DIODE - SILICON	1N4148	70035012
D8	DIODE - SILICON	1N4148	70035012
D9	DIODE - SILICON	1N4148	70035012

D10	DIODE - SILICON	1N4148	70035012
D11	DIODE - SILICON	1N4148	70035012
D12	DIODE - SILICON	1N4148	70035012
D13	DIODE - SILICON	1N4148	70035012
D14	DIODE - SILICON	1N4148	70035012
D15	DIODE - SILICON	1N4148	70035012
D16	DIODE - SILICON	1N4148	70035012
D17	DIODE - SILICON	1N4148	70035012
D18	DIODE - SILICON	1N4148	70035012
D19	DIODE - SILICON	1N4148	70035012
D20	DIODE - SILICON	1N4148	70035012
D21	DIODE - SILICON	1N4148	70035012
D22	DIODE - SILICON	1N4148	70035012
D23	DIODE - SILICON	1N4148	70035012
D24	DIODE - SILICON	1N4148	70035012
D25	DIODE - SILICON	1N4148	70035012
D26	DIODE - SILICON	1N4148	70035012
D27	DIODE - SILICON	1N4148	70035012
D28	DIODE - SILICON	1N4148	70035012
D29	DIODE - SILICON	1N4148	70035012
D30	DIODE - SILICON	1N4148	70035012
D31	DIODE - SILICON	1N4148	70035012
D32	DIODE - SILICON	1N4148	70035012
D33	DIODE - SILICON	1N4148	70035012
D34	DIODE - SILICON	1N4148	70035012
D35	DIODE - SILICON	1N4148	70035012
K1	RELAY - REED		70042208
P1	HEADER - NON POLARIZING (3 CKT)		70074921
P2	HEADER - NON POLARIZING (5 CKT)		70074923
P3	HEADER - NON POLARIZING (13 CKT)		70074931
P4	CONNECTOR - TOP ENTRY (4 CKT)		70074802
P5	CONNECTOR - TOP ENTRY (4 CKT)		70074802
P6	HEADER - NON POLARIZING (5 CKT)		70074923
P7	HEADER - NON POLARIZING (5 CKT)		70074923
P8	HEADER - POLARIZING (2 CKT)		70075002
P9	RECEPTACLE - PHONO JACK		21540902
P10	RECEPTACLE - PHONO JACK		21540902
Q1	TRANSISTOR - J FET (N-CHANNEL)	2N5484	70030901
Q2	TRANSISTOR - J FET (N-CHANNEL)	2N5484	70030901
Q3	TRANSISTOR - J FET (N-CHANNEL)	2N5484	70030901
Q4	TRANSISTOR - J FET (N-CHANNEL)	2N5484	70030901
Q5	TRANSISTOR - J FET (N-CHANNEL)	2N5484	70030901
Q6	TRANSISTOR - J FET (N-CHANNEL)	2N5484	70030901
Q7	TRANSISTOR - J FET (N-CHANNEL)	2N5484	70030901
Q8	TRANSISTOR - J FET (N-CHANNEL)	2N5484	70030901
Q9	TRANSISTOR - J FET (N-CHANNEL)	2N5484	70030901
Q10	TRANSISTOR - J FET (N-CHANNEL)	2N5484	70030901
Q11	TRANSISTOR - J FET (N-CHANNEL)	2N5484	70030901
Q12	TRANSISTOR - J FET (N-CHANNEL)	2N5484	70030901
Q13	TRANSISTOR - J FET (N-CHANNEL)	2N5484	70030901
Q14	TRANSISTOR - J FET (N-CHANNEL)	2N5484	70030901
Q15	TRANSISTOR - SILICON (PNP)	MPSA56	70030104
Q16	TRANSISTOR - J FET (N-CHANNEL)	2N5484	70030901
Q17	TRANSISTOR - SILICON (PNP)	MPSA56	70030104
Q18	TRANSISTOR - J FET (N-CHANNEL)	2N5484	70030901

Q19	TRANSISTOR - SILICON (NPN)	MPSA06	70030008
Q20	TRANSISTOR - SILICON (NPN)	MPSA06	70030008
Q21	TRANSISTOR - SILICON (PNP)	MPSA56	70030104
Q22	REGULATOR - VOLTAGE (ADJ NEG)	LM337T	70036508
Q23	REGULATOR - VOLTAGE (ADJ POS)	LM317T	70036507
R1	RESISTOR - CARBON (1/4W 5%)	10 K	79901103
R2	RESISTOR - CARBON (1/4W 5%)	1.2 K	79901122
R3	RESISTOR - CARBON (1/4W 5%)	68 K	79901683
R4	RESISTOR - CARBON (1/4W 5%)	10 K	79901103
R5	RESISTOR - CARBON (1/4W 5%)	1.2 K	79901122
R6	RESISTOR - CARBON (1/4W 5%)	68 K	79901683
R7	RESISTOR - CARBON (1/4W 5%)	10 K	79901103
R8	RESISTOR - CARBON (1/4W 5%)	1.2 K	79901122
R9	RESISTOR - CARBON (1/4W 5%)	68 K	79901683
R10	RESISTOR - CARBON (1/4W 5%)	330 Ω	79901331
R11	RESISTOR - CARBON (1/4W 5%)	100 K	79901104
R12	RESISTOR - CARBON (1/4W 5%)	2.7 K	79901272
R13	RESISTOR - CARBON (1/4W 5%)	33 K	79901333
R14	RESISTOR - CARBON (1/4W 5%)	33 K	79901333
R15	RESISTOR - CARBON (1/4W 5%)	47 K	79901473
R16	RESISTOR - CARBON (1/4W 5%)	47 K	79901473
R17	RESISTOR - CARBON (1/4W 5%)	33 K	79901333
R18	RESISTOR - CARBON (1/4W 5%)	33 K	79901333
R19	RESISTOR - CARBON (1/4W 5%)	2.7 K	79901272
R20	RESISTOR - CARBON (1/4W 5%)	100 K	79901104
R21	RESISTOR - CARBON (1/4W 5%)	330 Ω	79901331
R22	RESISTOR - CARBON (1/4W 5%)	10 K	79901103
R23	RESISTOR - CARBON (1/4W 5%)	1.2 K	79901122
R24	RESISTOR - CARBON (1/4W 5%)	68 K	79901683
R25	RESISTOR - CARBON (1/4W 5%)	10 K	79901103
R26	RESISTOR - CARBON (1/4W 5%)	1.2 K	79901122
R27	RESISTOR - CARBON (1/4W 5%)	68 K	79901683
R28	RESISTOR - CARBON (1/4W 5%)	10 K	79901103
R29	RESISTOR - CARBON (1/4W 5%)	1.2 K	79901122
R30	RESISTOR - CARBON (1/4W 5%)	68 K	79901683
R31	RESISTOR - CARBON (1/4W 5%)	68 K	79901683
* R32	POTENTIOMETER - SPECIAL	10 K	70040018
R33	RESISTOR - CARBON (1/4W 5%)	68 K	79901683
* R34	POTENTIOMETER - SPECIAL	10 K	70040018
R35	RESISTOR - CARBON (1/4W 5%)	68 K	79901683
* R36	POTENTIOMETER - SPECIAL	10 K	70040018
R37	RESISTOR - CARBON (1/4W 5%)	100 K	79901104
R38	RESISTOR - CARBON (1/4W 5%)	68 K	79901683
R39	RESISTOR - CARBON (1/4W 5%)	100 K	79901104
R40	RESISTOR - CARBON (1/4W 5%)	100 K	79901104
R41	RESISTOR - CARBON (1/4W 5%)	68 K	79901683
R42	RESISTOR - CARBON (1/4W 5%)	100 K	79901104
R43	RESISTOR - CARBON (1/4W 5%)	68 K	79901683
* R44	POTENTIOMETER - SPECIAL	10 K	70040018
R45	RESISTOR - CARBON (1/4W 5%)	68 K	79901683
* R46	POTENTIOMETER - SPECIAL	10 K	70040018
R47	RESISTOR - CARBON (1/4W 5%)	68 K	79901683
* R48	POTENTIOMETER - SPECIAL	10 K	70040018
R49	RESISTOR - CARBON (1/4W 5%)	10 K	79901103
R50	RESISTOR - CARBON (1/4W 5%)	1.2 K	79901122
R51	RESISTOR - CARBON (1/4W 5%)	68 K	79901683
R52	RESISTOR - CARBON (1/4W 5%)	10 K	79901103

R53	RESISTOR - CARBON (1/4W 5%)	1.2 K	79901122
R54	RESISTOR - CARBON (1/4W 5%)	68 K	79901683
R55	RESISTOR - CARBON (1/4W 5%)	10 K	79901103
R56	RESISTOR - CARBON (1/4W 5%)	1.2 K	79901122
R57	RESISTOR - CARBON (1/4W 5%)	68 K	79901683
R58	RESISTOR - CARBON (1/4W 5%)	18 K	79901183
R59	RESISTOR - CARBON (1/4W 5%)	1.8 K	79901182
R60	RESISTOR - CARBON (1/4W 5%)	470 K	79901474
R61	RESISTOR - CARBON (1/4W 5%)	100 K	79901104
R62	RESISTOR - CARBON (1/4W 5%)	100 Ω	79901101
R63	RESISTOR - CARBON (1/4W 5%)	100 Ω	79901101
R64	RESISTOR - CARBON (1/4W 5%)	100 K	79901104
R65	RESISTOR - CARBON (1/4W 5%)	470 K	79901474
R66	RESISTOR - CARBON (1/4W 5%)	1.8 K	79901182
R67	RESISTOR - CARBON (1/4W 5%)	18 K	79901183
R68	RESISTOR - CARBON (1/4W 5%)	39 K	79901393
R69	RESISTOR - CARBON (1/4W 5%)	10 K	79901103
R70	RESISTOR - CARBON (1/4W 5%)	1.2 K	79901122
R71	RESISTOR - CARBON (1/4W 5%)	68 K	79901683
R72	RESISTOR - CARBON (1/4W 5%)	10 K	79901103
R73	RESISTOR - CARBON (1/4W 5%)	1.2 K	79901122
R74	RESISTOR - CARBON (1/4W 5%)	68 K	79901683
R75	RESISTOR - CARBON (1/4W 5%)	10 K	79901103
R76	RESISTOR - CARBON (1/4W 5%)	1.2 K	79901122
R77	RESISTOR - CARBON (1/4W 5%)	68 K	79901683
R78	RESISTOR - CARBON (1/4W 5%)	68 K	79901683
R79	RESISTOR - CARBON (1/4W 5%)	68 K	79901683
* R80	POTENTIOMETER - SPECIAL	10 K	70040018
R81	RESISTOR - CARBON (1/4W 5%)	68 K	79901683
* R82	POTENTIOMETER - SPECIAL	10 K	70040018
R83	RESISTOR - CARBON (1/4W 5%)	68 K	79901683
* R84	POTENTIOMETER - SPECIAL	10 K	70040018
R85	RESISTOR - CARBON (1/4W 5%)	22 K	79901223
R86	RESISTOR - CARBON (1/4W 5%)	330 K	79901334
R87	RESISTOR - CARBON (1/4W 5%)	330 K	79901334
R88	RESISTOR - CARBON (1/4W 5%)	24 K	79901243
R89	RESISTOR - CARBON (1/4W 5%)	820 Ω	79901821
R90	RESISTOR - CARBON (1/4W 5%)	20 K	79901203
R91	RESISTOR - CARBON (1/4W 5%)	33 K	79901333
R92	RESISTOR - CARBON (1/4W 5%)	33 K	79901333
R93	RESISTOR - CARBON (1/4W 5%)	820 Ω	79901821
R94	RESISTOR - CARBON (1/4W 5%)	20 K	79901203
R95	RESISTOR - CARBON (1/4W 5%)	91 K	79901913
R96	RESISTOR - CARBON (1/4W 5%)	10 K	79901103
R97	RESISTOR - CARBON (1/4W 5%)	100 K	79901104
R98	RESISTOR - CARBON (1/4W 5%)	2.7 M	79901275
R99	RESISTOR - CARBON (1/4W 5%)	22 K	79901223
R100	RESISTOR - CARBON (1/4W 5%)	270 K	79901274
R101	RESISTOR - CARBON (1/4W 5%)	11 K	79901113
R102	RESISTOR - CARBON (1/4W 5%)	5.6 K	79901562
R103	RESISTOR - CARBON (1/4W 5%)	68 K	79901683
* R104	POTENTIOMETER - SPECIAL	10 K	70040018
R105	RESISTOR - CARBON (1/4W 5%)	68 K	79901683
* R106	POTENTIOMETER - SPECIAL	10 K	70040018
R107	RESISTOR - CARBON (1/4W 5%)	68 K	79901683
* R108	POTENTIOMETER - SPECIAL	10 K	70040018
R109	RESISTOR - CARBON (1/4W 5%)	10 K	79901103
R110	RESISTOR - CARBON (1/4W 5%)	1.2 K	79901122

R111	RESISTOR - CARBON (1/4W 5%)	91 K	79901913
R112	RESISTOR - CARBON (1/4W 5%)	10 K	79901103
R113	RESISTOR - CARBON (1/4W 5%)	110 K	79901114
R114	RESISTOR - CARBON (1/4W 5%)	100 K	79901104
R115	RESISTOR - CARBON (1/4W 5%)	1 K	79901102
R116	RESISTOR - CARBON (1/4W 5%)	100 K	79901104
R117	RESISTOR - CARBON (1/4W 5%)	3.9 K	79901392
R118	RESISTOR - CARBON (1/4W 5%)	10 K	79901103
R119	RESISTOR - CARBON (1/4W 5%)	220 K	79901224
R120	RESISTOR - CARBON (1/4W 5%)	56 K	79901563
R121	RESISTOR - CARBON (1/4W 5%)	150 K	79901154
R122	RESISTOR - CARBON (1/4W 5%)	100 K	79901104
R123	RESISTOR - CARBON (1/4W 5%)	100 K	79901104
R124	RESISTOR - CARBON (1/4W 5%)	150 K	79901154
R125	RESISTOR - CARBON (1/4W 5%)	56 K	79901563
R126	RESISTOR - CARBON (1/4W 5%)	220 K	79901224
R127	RESISTOR - CARBON (1/4W 5%)	10 K	79901103
R128	RESISTOR - CARBON (1/4W 5%)	3.9 K	79901392
R129	RESISTOR - CARBON (1/4W 5%)	100 K	79901104
R130	RESISTOR - CARBON (1/4W 5%)	47 K	79901473
R131	RESISTOR - CARBON (1/4W 5%)	1 K	79901102
R132	RESISTOR - CARBON (1/4W 5%)	47 K	79901473
R133	RESISTOR - CARBON (1/4W 5%)	10 K	79901103
R134	RESISTOR - CARBON (1/4W 5%)	1.2 K	79901122
R135	RESISTOR - CARBON (1/4W 5%)	68 K	79901683
R136	POTENTIOMETER - SPECIAL	10 K	70040018
R137	RESISTOR - CARBON (1/4W 5%)	1 M	79901105
R138	RESISTOR - CARBON (1/4W 5%)	39 K	79901393
R139	RESISTOR - CARBON (1/4W 5%)	39 K	79901393
R140	RESISTOR - CARBON (1/4W 5%)	10 K	79901103
R141	RESISTOR - CARBON (1/4W 5%)	10 K	79901103
R142	RESISTOR - CARBON (1/4W 5%)	13 K	79901133
R143	RESISTOR - CARBON (1/4W 5%)	10 K	79901103
R144	RESISTOR - CARBON (1/4W 5%)	150 K	79901154
R145	RESISTOR - CARBON (1/4W 5%)	220 K	79901224
R146	RESISTOR - CARBON (1/4W 5%)	68 K	79901683
R147	RESISTOR - CARBON (1/4W 5%)	2.2 K	79901222
R148	RESISTOR - CARBON (1/4W 5%)	68 K	79901683
R149	RESISTOR - CARBON (1/4W 5%)	68 K	79901683
R150	RESISTOR - CARBON (1/4W 5%)	68 K	79901683
R151	RESISTOR - CARBON (1/4W 5%)	910 Ω	79901911
R152	RESISTOR - CARBON (1/4W 5%)	1 K	79901102
R153	RESISTOR - CARBON (1/4W 5%)	470 Ω	79901471
R154	RESISTOR - CARBON (1/4W 5%)	22 K	79901223
R155	RESISTOR - CARBON (1/4W 5%)	10 K	79901103
R156	NOT USED		
R157	RESISTOR - CARBON (1/4W 5%)	100 K	79901104
R158	RESISTOR - CARBON (1/4W 5%)	68 K	79901683
R159	RESISTOR - CARBON (1/4W 2%)	120 Ω	79902121
R160	RESISTOR - CARBON (1/4W 2%)	1.3 K	79902132
R161	RESISTOR - WIREWOUND	150 Ω	70012510
R162	RESISTOR - CARBON (1/4W 5%)	1 K	79901102
R163	RESISTOR - CARBON (1/4W 5%)	91 K	79901913
R164	RESISTOR - CARBON (1/4W 5%)	110 K	79901114
R165	RESISTOR - CARBON (1/4W 5%)	100 K	79901104
R166	RESISTOR - CARBON (1/4W 5%)	33 K	79901333
R167	RESISTOR - CARBON (1/4W 5%)	33 K	79901333
R168	RESISTOR - CARBON (1/4W 5%)	68 K	79901683

R169	RESISTOR - CARBON (1/4W 5%)	68 K	79901683
R170	RESISTOR - CARBON (1/4W 5%)	68 K	79901683
R171	RESISTOR - CARBON (1/4W 5%)	2.2 K	79901222
R172	RESISTOR - CARBON (1/4W 5%)	10 K	79901103
R173	RESISTOR - CARBON (1/4W 5%)	10 K	79901103
* R174	POTENTIOMETER	10 K	70040014
R175	RESISTOR - CARBON (1/4W 5%)	22 K	79901223
* R176	POTENTIOMETER - SPECIAL	10 K	70040018
R177	RESISTOR - CARBON (1/4W 5%)	68 K	79901683
R178	RESISTOR - CARBON (1/4W 2%)	220 Ω	79902221
R179	RESISTOR - CARBON (1/4W 2%)	2.4 K	79902242
R180	RESISTOR - WIREWOUND	150 Ω	70012510
R181	RESISTOR - CARBON (1/4W 5%)	10 K	79901103
R182	RESISTOR - CARBON (1/4W 5%)	10 K	79901103
R183	RESISTOR - CARBON (1/4W 5%)	910 Ω	79901911
R184	RESISTOR - CARBON (1/4W 5%)	680 Ω	79901681
R185	RESISTOR - CARBON (1/4W 5%)	4.7 K	79901472
R186	RESISTOR - CARBON (1/4W 5%)	4.7 K	79901472
S1	SWITCH - DIP		70042902
U1	IC - DUAL OP AMP	LM833	30800238
U2	IC - DUAL OP AMP	LM833	30800238
U3	IC - DUAL OP AMP	LM833	30800238
U4	IC - DUAL OP AMP	LM833	30800238
U5	IC - DUAL OP AMP	LM348	30800215
U6	IC - DUAL OP AMP	LM833	30800238
U7	IC - DUAL OP AMP	LM833	30800238

* Requires Potentiometer Adjustment Shaft, Part Number 21621101.

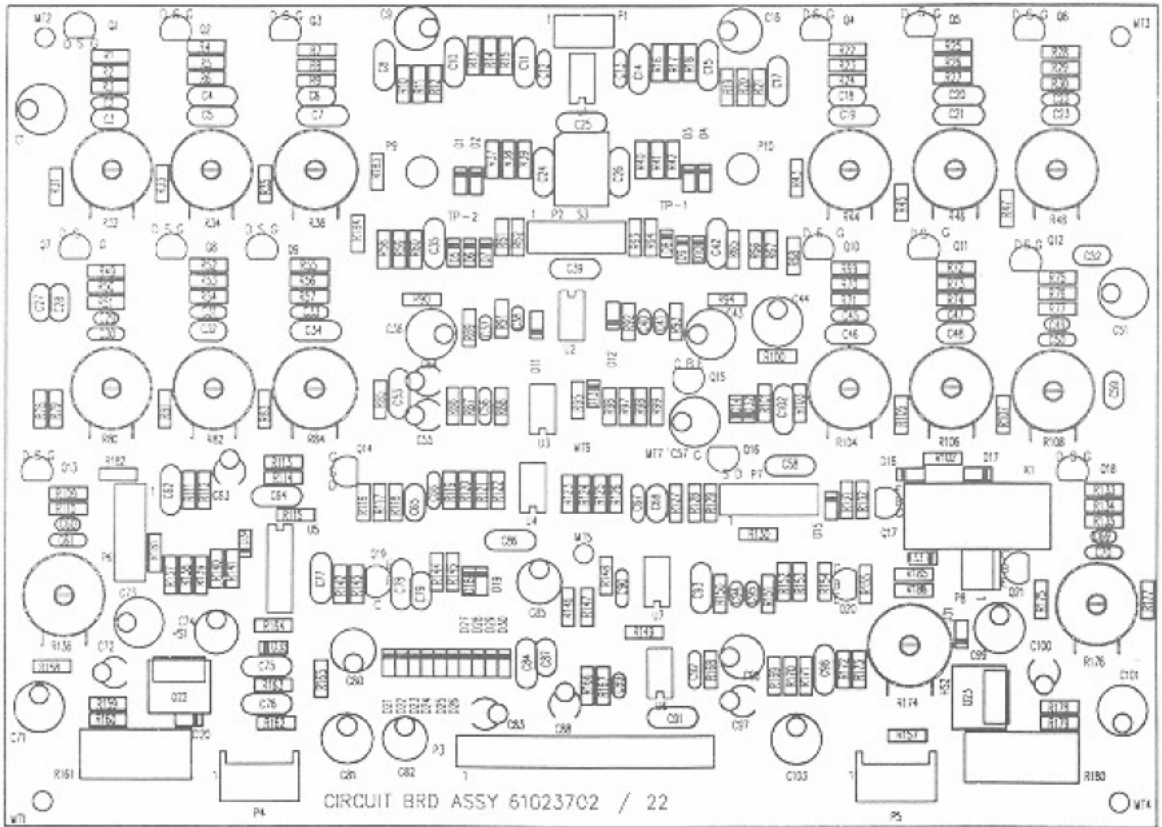
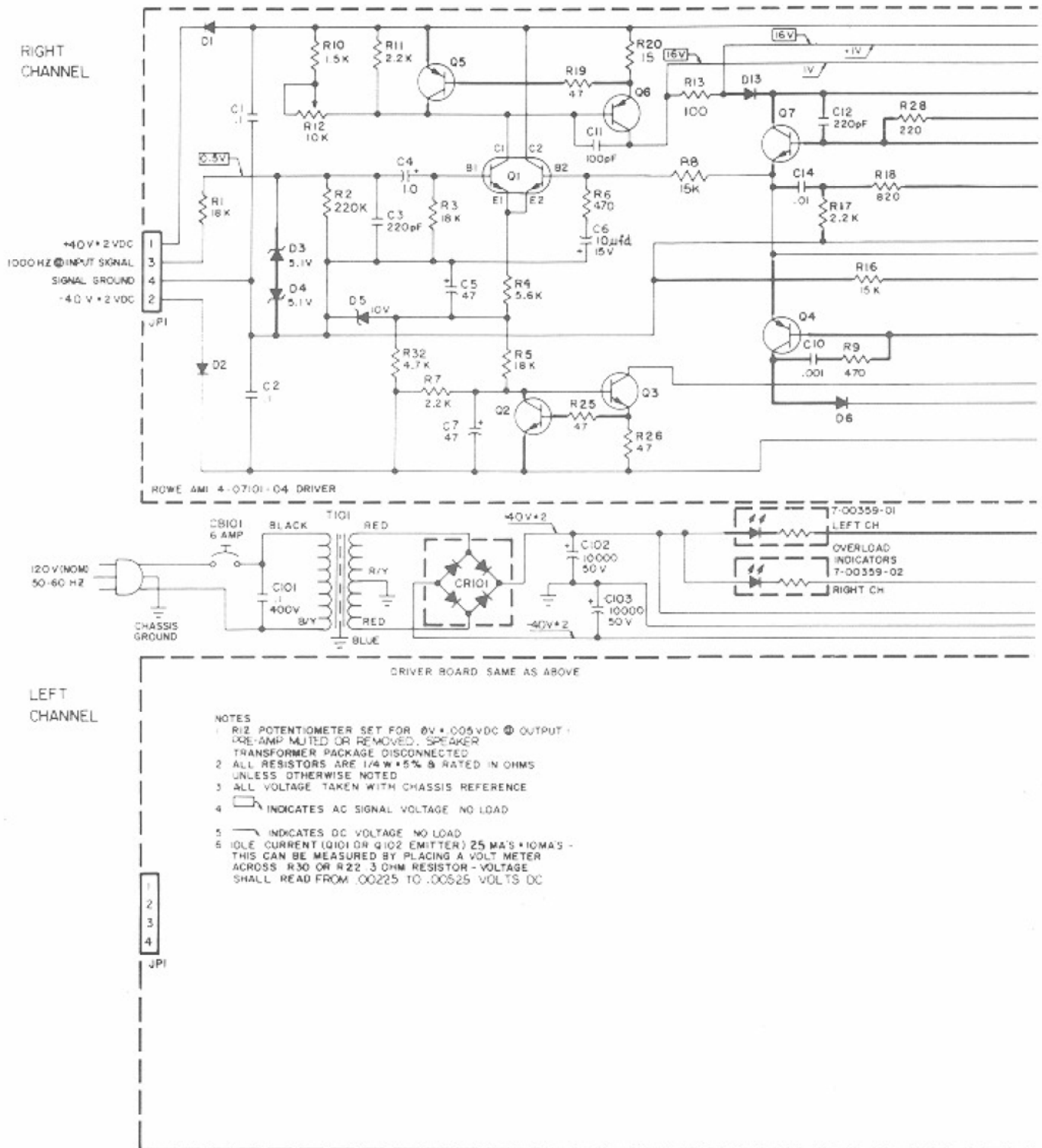
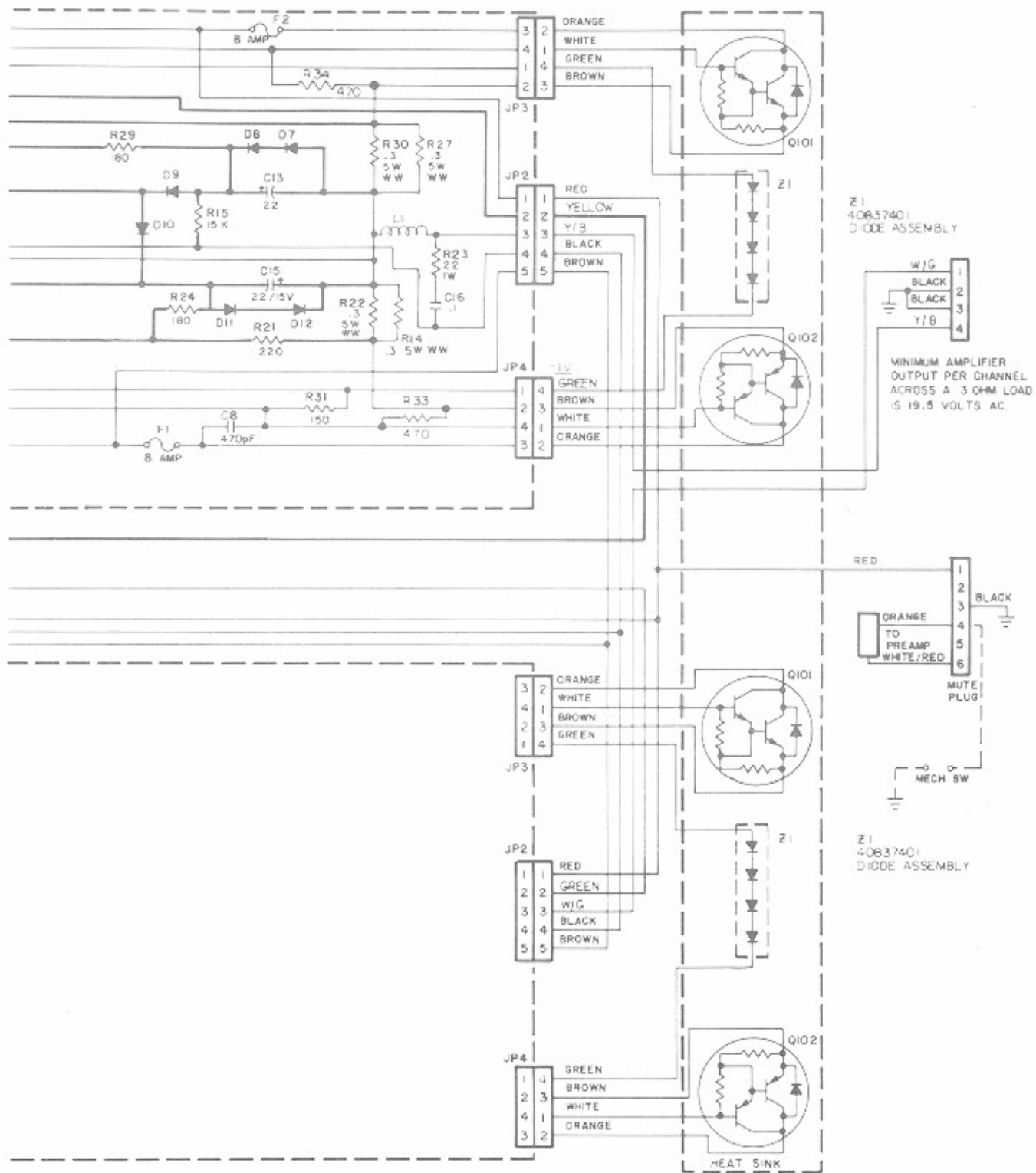

Figure 5-7B. Preamplifier Circuit Board Layout





(See Figure 8-15 for the pictorial view of the heat sink)

For Equivalent Engineering Drawing See 61024901/02-Q2 D

Figure 5-8A. Schematic Diagram - 250 Watt Power Amp

COMPONENT LIST FOR AMPLIFIER DRIVER BOARD 40710104-J

C1	Capacitor - Mylar	.1 MF	70021549
C2	Capacitor - Mylar	.1 MF	70021549
C3	Capacitor - Monolithic Ceramic	220 PF	70028606
C4	Capacitor - Electrolytic	1 MF	70023804
C5	Capacitor - Electrolytic	47 MF	70023812
C6	Capacitor - Electrolytic	10 MF	70023808
C7	Capacitor - Electrolytic	47 MF	70023812
C8	Capacitor - Monolithic Ceramic	470 PF	70028612
C9	NOT USED		
C10	Capacitor - Monolithic Ceramic	.001 MF	70028618
C11	Capacitor - Monolithic Ceramic	100 PF	70028601
C12	Capacitor - Monolithic Ceramic	220 PF	70028606
C13	Capacitor - Electrolytic	22 MF	70023810
C14	Capacitor - Monolithic Ceramic	.01 MF	70028636
C15	Capacitor - Electrolytic	22 MF	70023810
C16	Capacitor - Mylar	.1 MF	70021549
CR1	Diode - Silicon		70035005
CR2	Diode - Silicon		70035005
CR3	Diode - Zener	(5.1 V)	70035527
CR4	Diode - Zener	(5.1 V)	70035527
CR5	Diode - Zener	(10 V)	70035514
CR6	Diode - Silicon		70035005
CR7	Diode - Silicon		70035005
CR8	Diode - Silicon		70035005
CR9	Diode - Silicon		70035005
CR10	Diode - Silicon		70035005
CR11	Diode - Silicon		70035005
CR12	Diode - Silicon		70035005
CR13	Diode - Silicon		70035005
F1	Fuse (8 Amp)		70072002
F2	Fuse (8 Amp)		70072002
L1	Inductor - Coil		21940701
P1	Wafer - Non-Polarizing	(4 CKT)	70074904
P2	Wafer - Polarizing	(5 CKT)	70075005
P3	Wafer - Polarizing	(4 CKT)	70075004
P4	Wafer - Polarizing	(4 CKT)	70075004
Q1	Transistor - Silicon (Dual)	(NPN)	70030301
Q2	Transistor - Silicon	(NPN)	70030008
Q3	Transistor - Silicon	(NPN)	70033006
Q4	Transistor - Silicon	(PNP)	70030104
Q5	Transistor - Silicon	(PNP)	70030104
Q6	Transistor - Silicon	(PNP)	70030403
Q7	Transistor - Silicon	(NPN)	70030008

Note: All resistors are ¼ watt 5%, unless otherwise noted.

R1	Resistor - Carbon	18 K Ω	79901183
R2	Resistor - Carbon	220 K Ω	79901224
R3	Resistor - Carbon	18 K Ω	79901183
R4	Resistor - Carbon	5.6 K Ω	79901562
R5	Resistor - Carbon	18 K Ω	79901183
R6	Resistor - Carbon	470 Ω	79901471
R7	Resistor - Carbon	2.2 Ω	79901222
R8	Resistor - Carbon	15 K Ω	79901153
R9	Resistor - Carbon	470 Ω	79901471
R10	Resistor - Carbon	1.5 K Ω	79901152
R11	Resistor - Carbon	2.2 K Ω	79901222
R12	Resistor - Potentiometer	10 K Ω	70040014
R13	Resistor - Carbon	100 Ω	79901101
R14	Resistor - Wire Wound	.3 Ω	70011805
R15	Resistor - Carbon	15 K Ω	79901153
R16	Resistor - Carbon	15 K Ω	79901153
R17	Resistor - Carbon	2.2 K Ω	79901222
R18	Resistor - Carbon	820 Ω	79901821
R19	Resistor - Carbon	47 Ω	79901470
R20	Resistor - Carbon	15 Ω	79901150
R21	Resistor - Carbon	180 Ω	79901181
R22	Resistor - Wire Wound	.3 Ω	70011805
R23	Resistor - Wire Wound	22 Ω	79920220
R24	Resistor - Carbon	180 Ω	79901181
R25	Resistor - Carbon	47 Ω	79901470
R26	Resistor - Carbon	47 Ω	79901470
R27	Resistor - Wire Wound	.3 Ω (5 W, 10%)	70011805
R28	Resistor - Carbon	180 Ω	79901181
R29	Resistor - Carbon	180 Ω	79901181
R30	Resistor - Wire Wound	.3 Ω (5 W, 10%)	70011805
R31	Resistor - Carbon	220 Ω	79901221
R32	Resistor - Carbon	4.7 K Ω	79901472
R33	Resistor - Carbon	470 Ω	79901471
R34	Resistor - Carbon	470 Ω	79901471

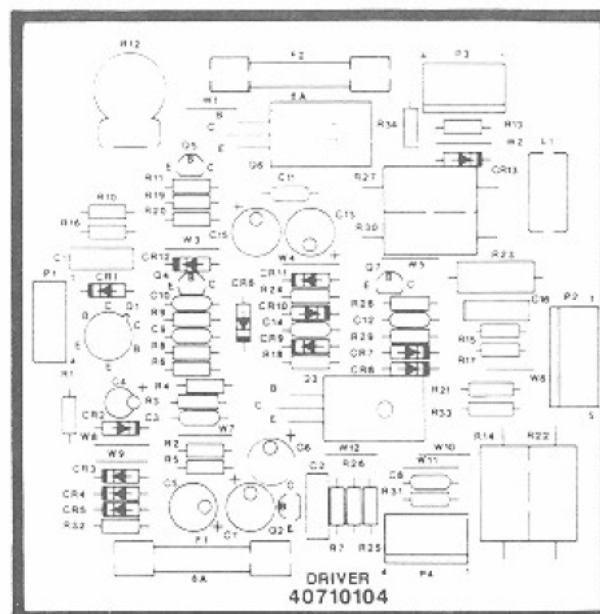
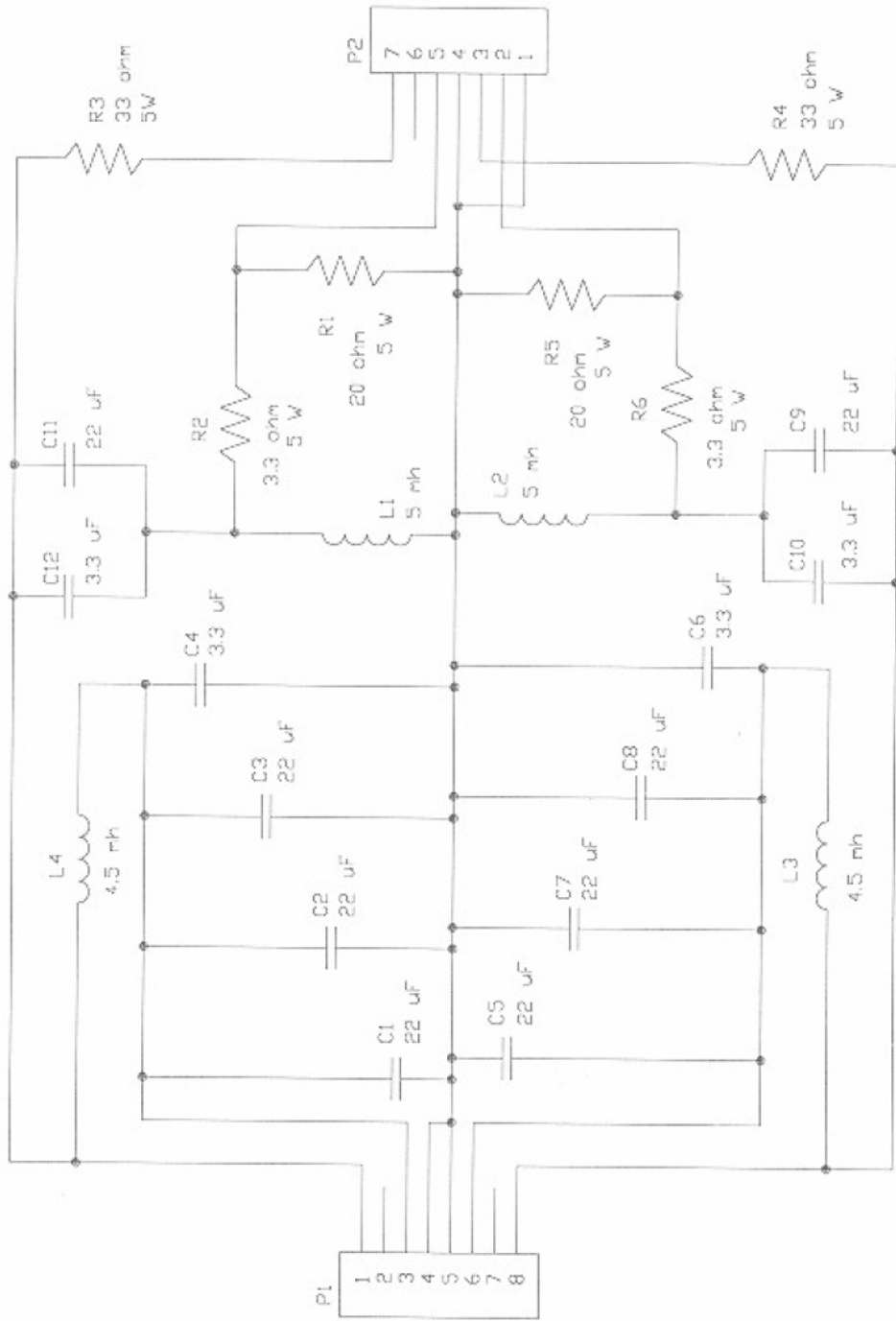

Figure 5-8B. Amplifier Driver Board Layout



For Equivalent Engineering Drawing See 61052701-62 D

Figure 5-8C. Schematic Diagram - Crossover Network

**COMPONENTS LIST FOR
CROSSOVER NETWORK (61052701)-D**

C1	CAPACITOR - BI-POLAR ELECTROLYTIC	22 μ F	70022809	SEE NOTE
C2	CAPACITOR - BI-POLAR ELECTROLYTIC	22 μ F	70022809	SEE NOTE
C3	CAPACITOR - BI-POLAR ELECTROLYTIC	22 μ F	70022809	SEE NOTE
C4	CAPACITOR - BI-POLAR ELECTROLYTIC	3.3 μ F	70022801	SEE NOTE
C5	CAPACITOR - BI-POLAR ELECTROLYTIC	22 μ F	70022809	SEE NOTE
C6	CAPACITOR - BI-POLAR ELECTROLYTIC	3.3 μ F	70022801	SEE NOTE
C7	CAPACITOR - BI-POLAR ELECTROLYTIC	22 μ F	70022809	SEE NOTE
C8	CAPACITOR - BI-POLAR ELECTROLYTIC	22 μ F	70022809	SEE NOTE
C9	CAPACITOR - BI-POLAR ELECTROLYTIC	22 μ F	70022809	SEE NOTE
C10	CAPACITOR - BI-POLAR ELECTROLYTIC	3.3 μ F	70022801	SEE NOTE
C11	CAPACITOR - BI-POLAR ELECTROLYTIC	22 μ F	70022809	SEE NOTE
C12	CAPACITOR - BI-POLAR ELECTROLYTIC	3.3 μ F	70022801	SEE NOTE
L1	INDUCTOR	5 mH	70041404	OR 70041302
L2	INDUCTOR	5 mH	70041404	OR 70041302
L3	INDUCTOR	4.5 mH	70041406	OR 70041301
L4	INDUCTOR	4.5 mH	70041406	OR 70041301
P1	HEADER - VERTICAL POLARIZED (8CKT)		70075008	
P2	HEADER - VERTICAL POLARIZED (7CKT)		70075007	
R1	RESISTOR - WIREWOUND 5W	20 Ω	70012514	
R2	RESISTOR - WIREWOUND 5W	3.3 Ω	70012513	
R3	RESISTOR - WIREWOUND 5W	33 Ω	70012512	
R4	RESISTOR - WIREWOUND 5W	33 Ω	70012512	
R5	RESISTOR - WIREWOUND 5W	20 Ω	70012514	
R6	RESISTOR - WIREWOUND 5W	3.3 Ω	70012513	

NOTE: THE FOLLOWING SUBSTITUTIONS ARE AUTHORIZED TO BENEFIT COST OR PROCUREMENT.

$C1(22\mu F) + C2(22\mu F) + C3(22\mu F) + C4(3.3\mu F) = 69.3\mu F$
 $C5(22\mu F) + C7(22\mu F) + C8(22\mu F) + C6(3.3\mu F) = 69.3\mu F$

OR

$C2(33\mu F) + C3(33\mu F) + C4(3.3\mu F) = 69.3\mu F$
 $C7(33\mu F) + C8(33\mu F) + C6(3.3\mu F) = 69.3\mu F$

C1 AND C5 NOT USED
 EITHER OF THE ABOVE COMBINATIONS MAY BE USED TO OBTAIN THE NOMINAL 69.3 μ F. THE
 33 μ F IS A 70022811.

AMPLIFIER FULL POWER OUTPUT VOLTAGES (PER CHANNEL)

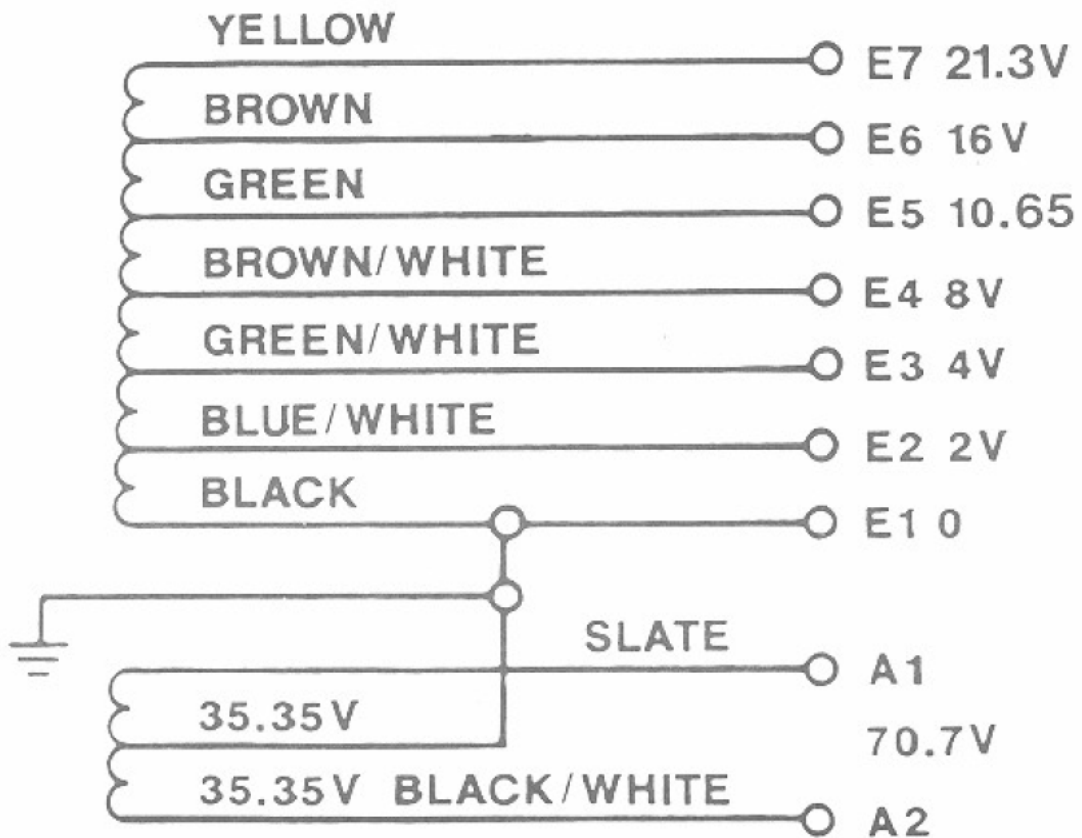
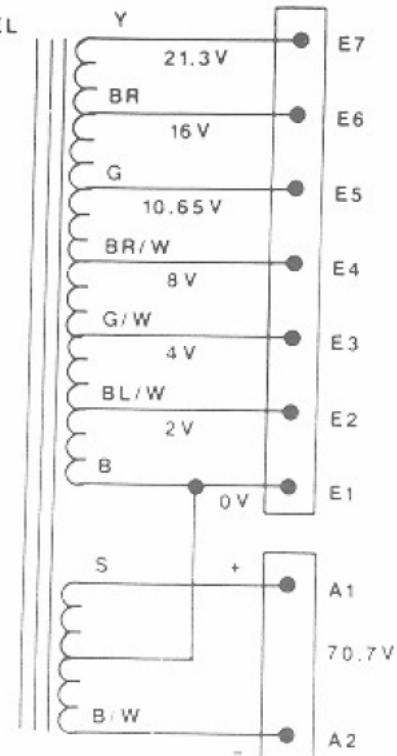
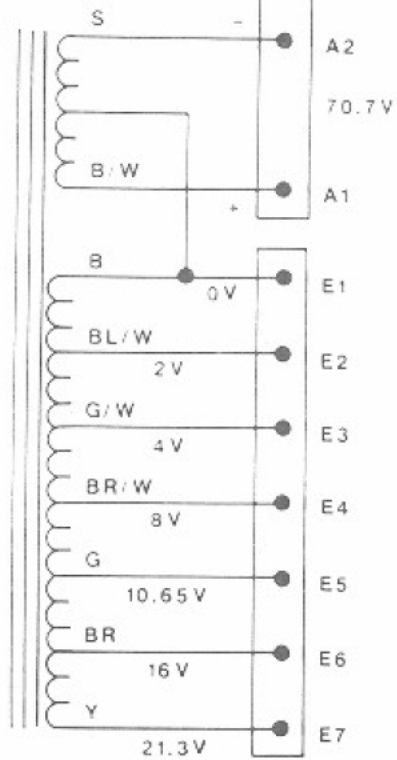

Figure 5-9. Transformer Output Voltages

RIGHT CHANNEL



LEFT CHANNEL



For Equivalent Engineering Drawing See 40832101-Q2 A

Figure 5-10. Transformer Wiring Diagram

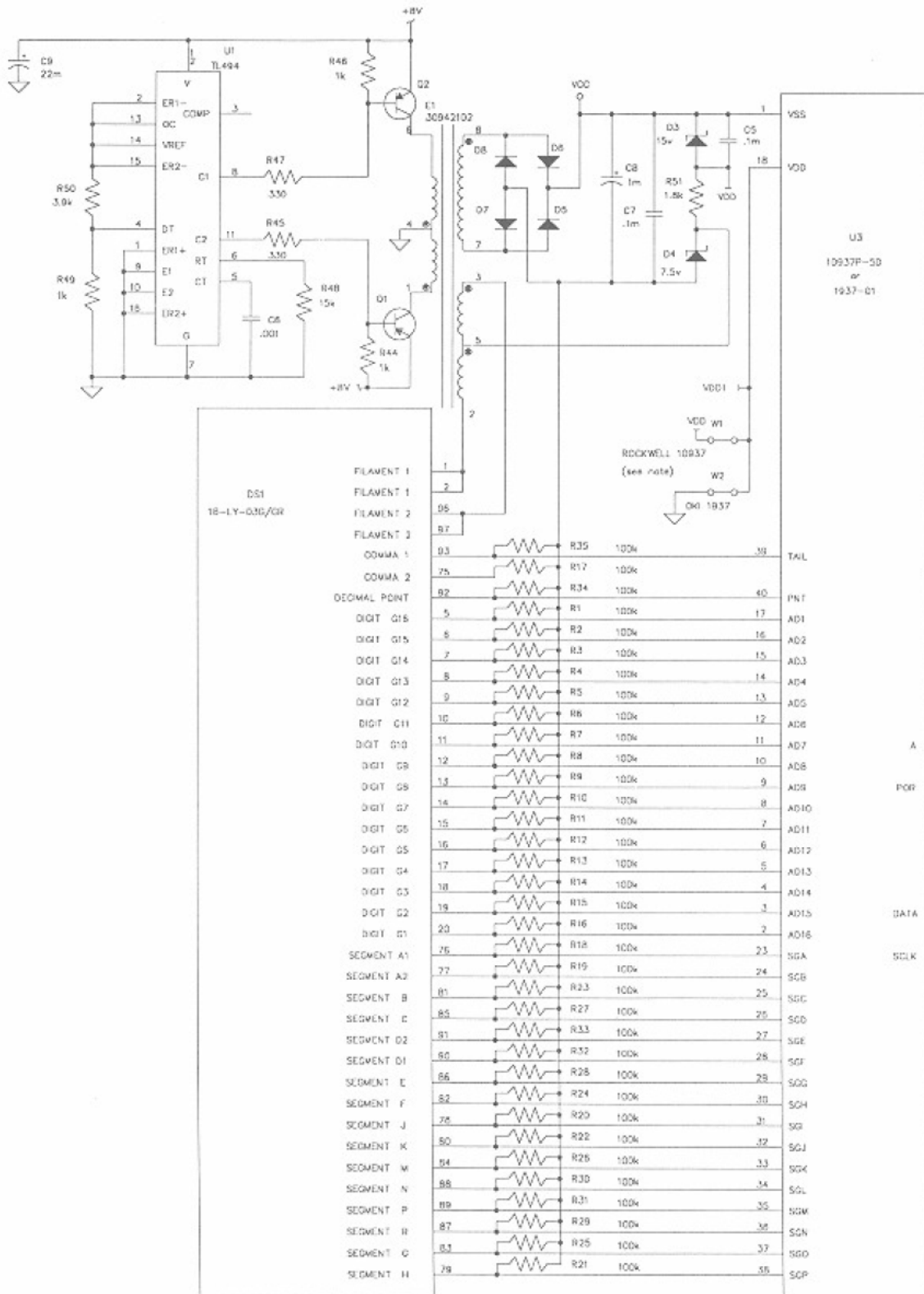

NOTE:

AT U3	W1	W2
30800237	USED	NOT USED
30800258	NOT USED	USED

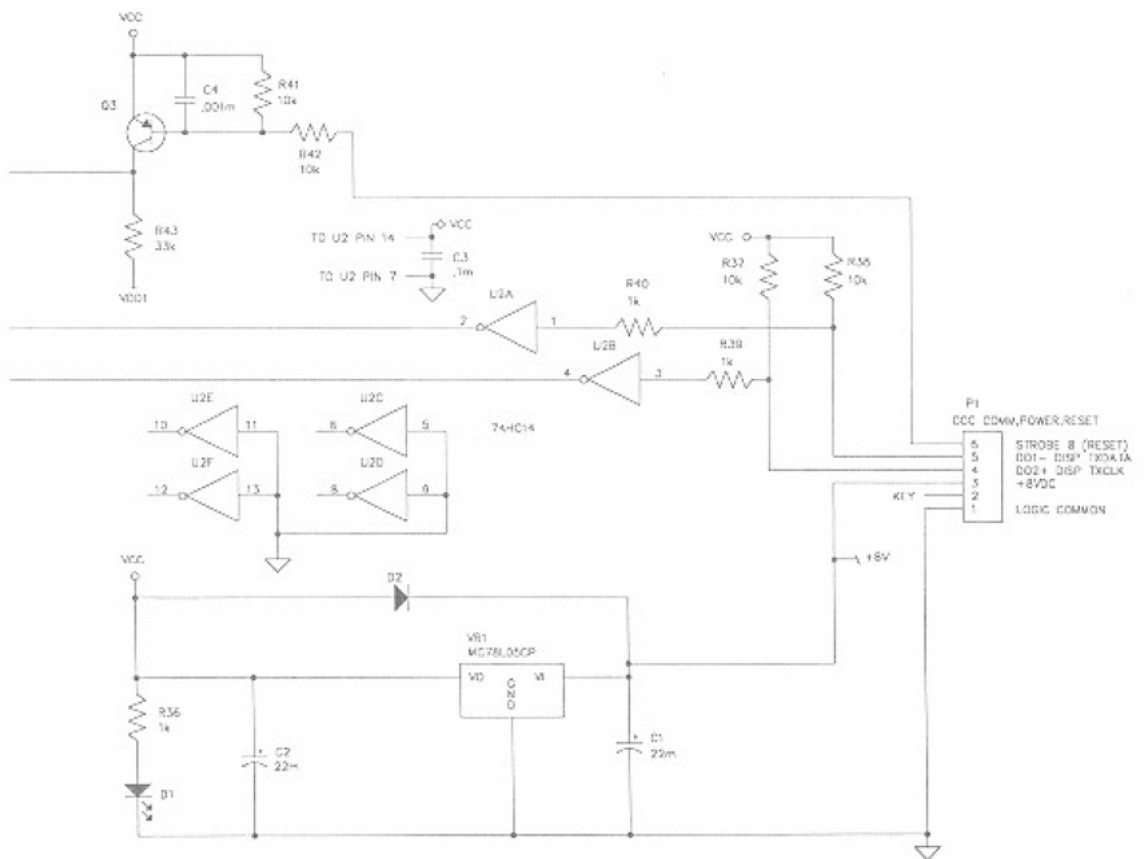

For Equivalent Engineering Drawing See 40855001-Q2

Figure 5-11. Display Assembly

COMPONENT LIST FOR THE DISPLAY ASSEMBLY (40855001)

C1	CAPACITOR-TANTALUM 15 VDC 10%	22 μ F	70025104
C2	CAPACITOR-TANTALUM 15 VDC 10%	22 μ F	70025104
C3	CAPACITOR-MONOLYTHIC CERAMIC	.1 μ F	70028511
C4	CAPACITOR-MONOLYTHIC CERAMIC 10%	.001 μ F	70028618
C5	CAPACITOR-MONOLYTHIC CERAMIC	.1 μ F	70028511
C6	CAPACITOR-MONOLYTHIC CERAMIC 10%	.001 μ F	70028618
C7	CAPACITOR-MONOLYTHIC CERAMIC	.1 μ F	70028511
C8	CAPACITOR-ELECTROLYTIC 100 VDC 20%	1 μ F	70028101
C9	CAPACITOR-TANTALUM 15 VDC 10%	22 μ F	70025104
D1	DIODE - LIGHT EMITTING RED DIFFUSED		70035305
D2	DIODE - SILICON	1N4004	70035005
D3	DIODE - ZENER 15V 1/2W 5%	1N965B	70035522
D4	DIODE - ZENER 7.5V 1/2W 5%	1N958B	70035520
D5	DIODE - SILICON	1N4148	70035012
D6	DIODE - SILICON	1N4148	70035012
D7	DIODE - SILICON	1N4148	70035012
D8	DIODE - SILICON	1N4148	70035012
DS1	DISPLAY - VAC FLU (16 CHAR)	16-LY-03G	30933204
E1	TRANSFORMER DC-DC/AC	30942102	
P1	HEADER - POLARIZED .156 6 POSITION	70075006	
Q1	TRANSISTOR - SILICON PNP	MPSA56	70030104
Q2	TRANSISTOR - SILICON PNP	MPSA56	70030104
Q3	TRANSISTOR - SILICON PNP	MPSA56	70030104
R1-R35	RESISTOR - CARBON FILM 1/8W 5%	100 K	79905104
R36	RESISTOR - CARBON FILM 1/4W 5%	1 K	79901102
R37	RESISTOR - CARBON FILM 1/4W 5%	10 K	79901103
R38	RESISTOR - CARBON FILM 1/4W 5%	10 K	79901103
R39	RESISTOR - CARBON FILM 1/4W 5%	1 K	79901102
R40	RESISTOR - CARBON FILM 1/4W 5%	1 K	79901102
R41	RESISTOR - CARBON FILM 1/4W 5%	10 K	79901103
R42	RESISTOR - CARBON FILM 1/4W 5%	10 K	79901103
R43	RESISTOR - CARBON FILM 1/4W 5%	33 K	79901333
R44	RESISTOR - CARBON FILM 1/4W 5%	1 K	79901102
R45	RESISTOR - CARBON FILM 1/4W 5%	330 OHM	79901331
R46	RESISTOR - CARBON FILM 1/4W 5%	1 K	79901102
R47	RESISTOR - CARBON FILM 1/4W 5%	330 OHM	79901331
R48	RESISTOR - CARBON FILM 1/4W 5%	15 K	79901153
R49	RESISTOR - CARBON FILM 1/4W 5%	1 K	79901102
R50	RESISTOR - CARBON FILM 1/4W 5%	3.9 K	79901392
R51	RESISTOR - CARBON FILM 1/4W 5%	1.8 K	79901182

U1	I.C.-PWM CONTROL CIRCUIT	TL494	30800257
U2	SCHMITT TRIGGER INVERTER	74HC14I.C.-HEX	79940014
U3	DRIVER-DISPLAY (VAC FLU)	10937P-50	30800237 SEE NOTE
	OR		
	DRIVER-DISPLAY (VAC FLU)	MSC1937-01	30800258 SEE NOTE
VR1	REGULATOR-VOLTAGE (LINEAR IC)	MC78L05ACP	70036515
W1	WIRE - BARE		00503200 SEE NOTE
W2	WIRE - BARE		00503200 SEE NOTE

NOTE: INSERT W1 (W2 OPEN) IF ROCKWELL 10937 (30800237) AT U3.
 INSERT W2 (W1 OPEN) IF OKI 1937 (30800258) AT U3.

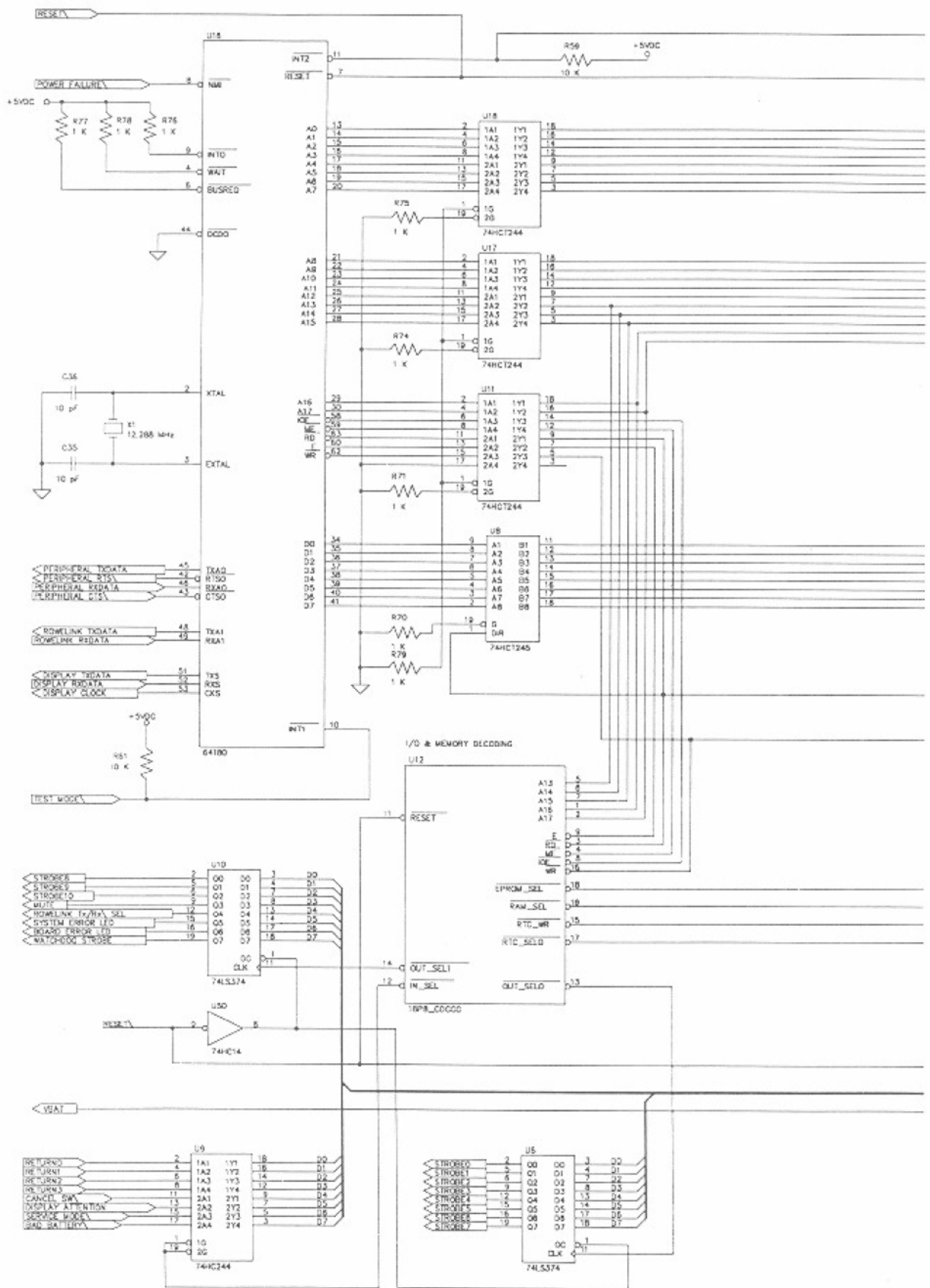

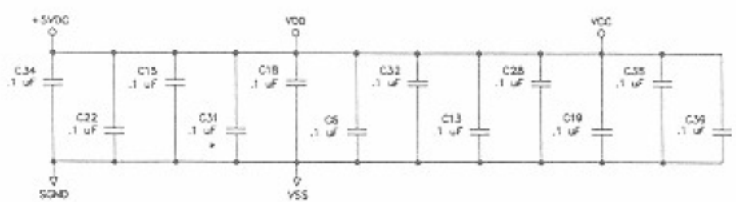
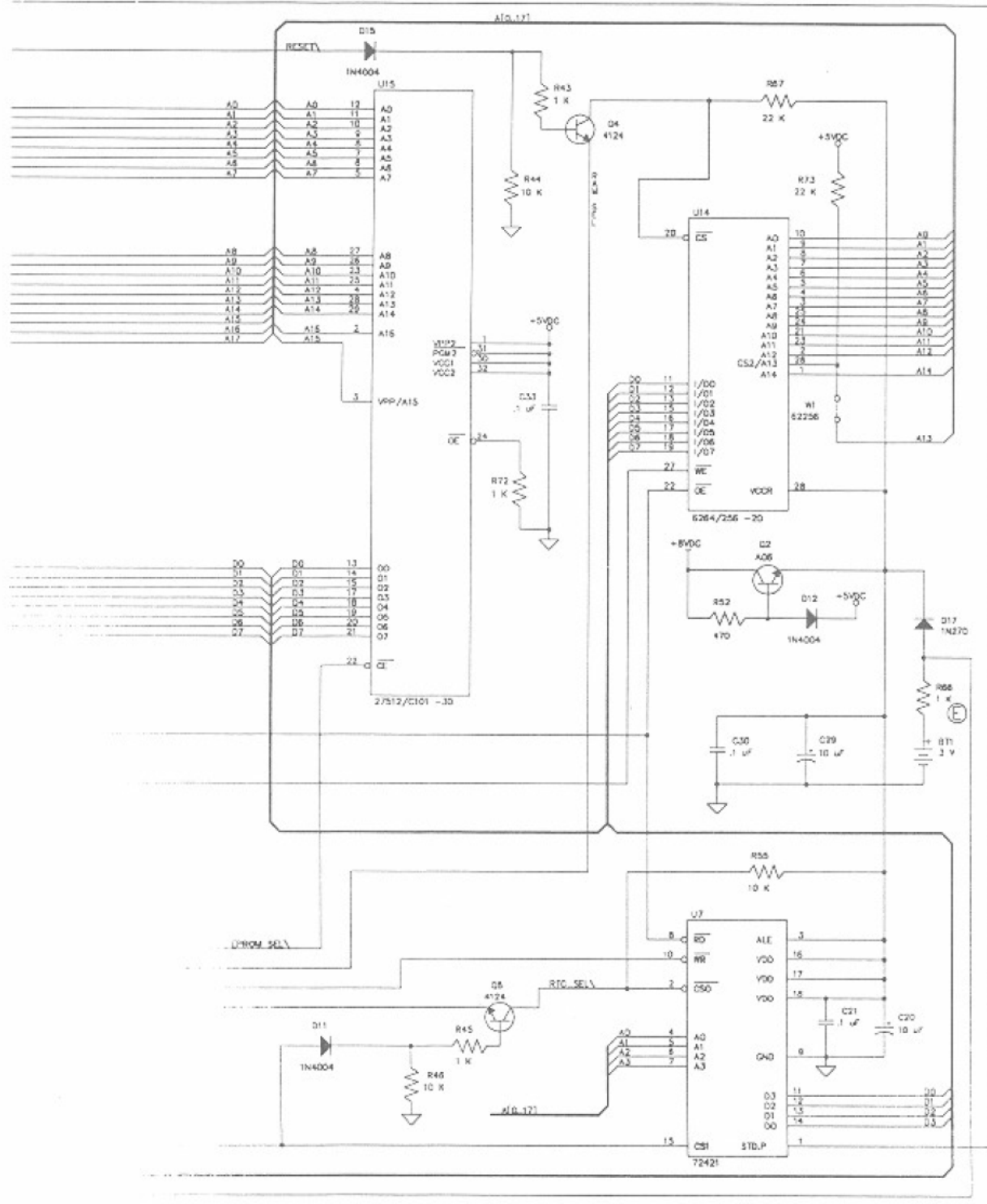

For Equivalent Engineering Drawing See 61031101-Q2 E

Figure 5-12A. Central Control Computer Schematic, Sheet 1

DISPLAY/KEYBOARD INTERFACE

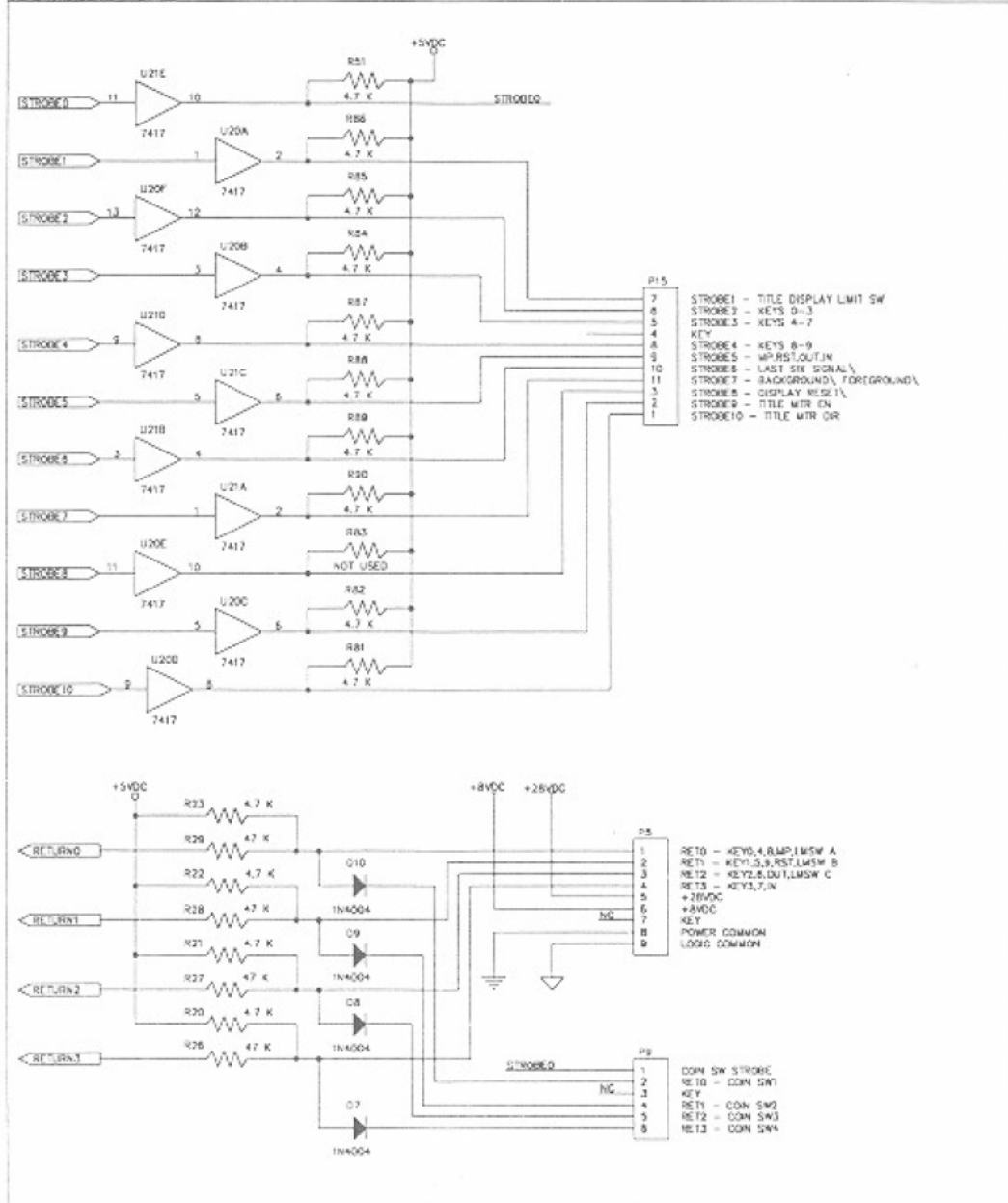

DISPLAY INTERFACE (53422)

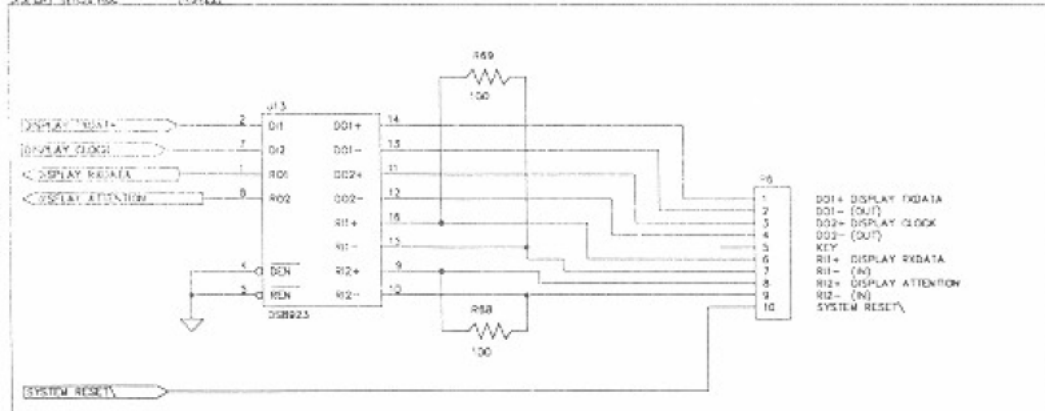

ROWLINK (DS445)

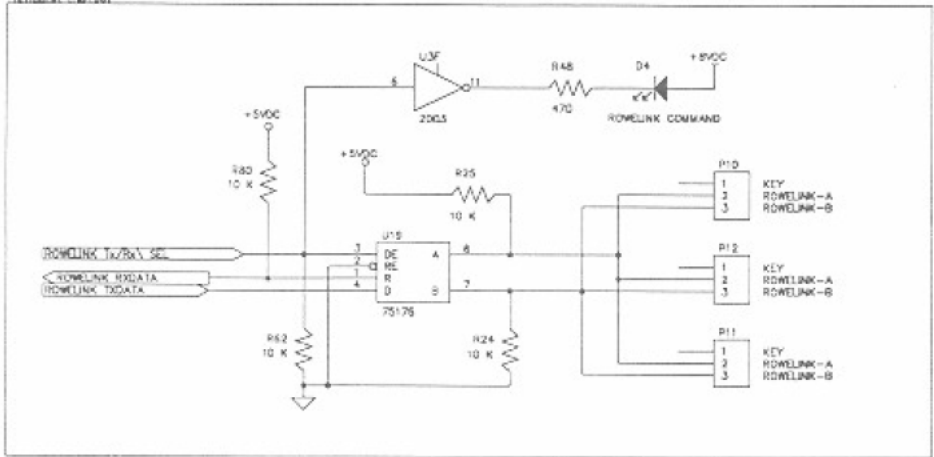

MISC INTERFACE

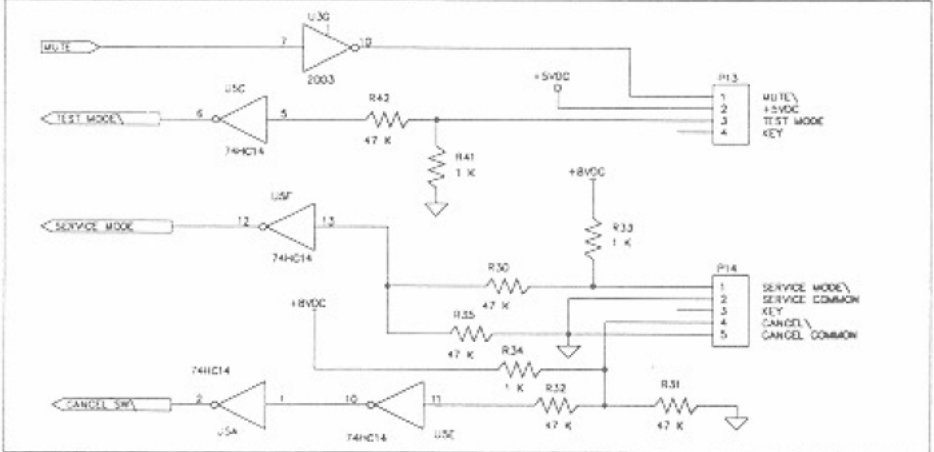

PERIPHERAL INTERFACE (DS232C)

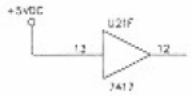
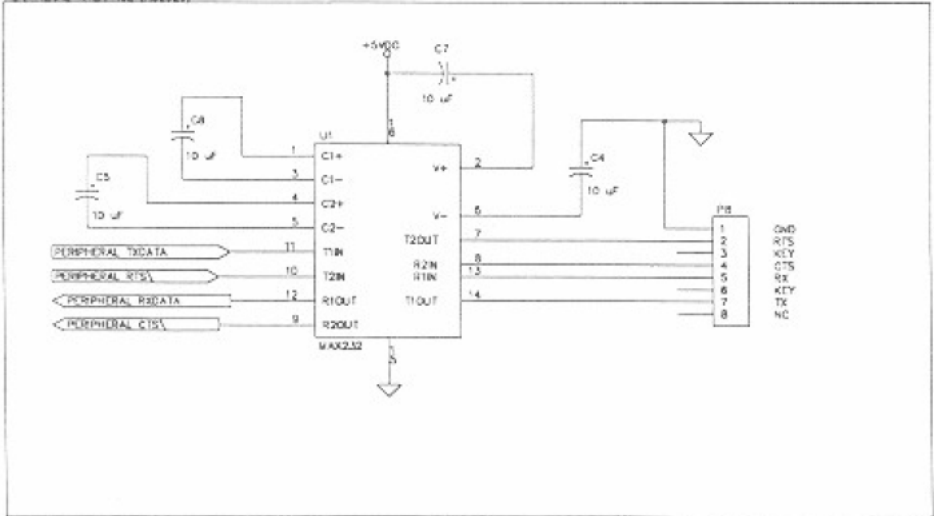

For Equivalent Engineering Drawing See 61031101-Q2 E

Figure 5-12A. Central Control Computer Schematic, Sheet 2

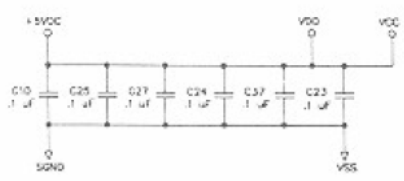
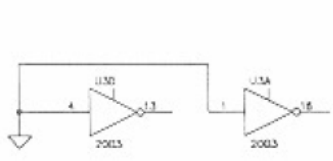
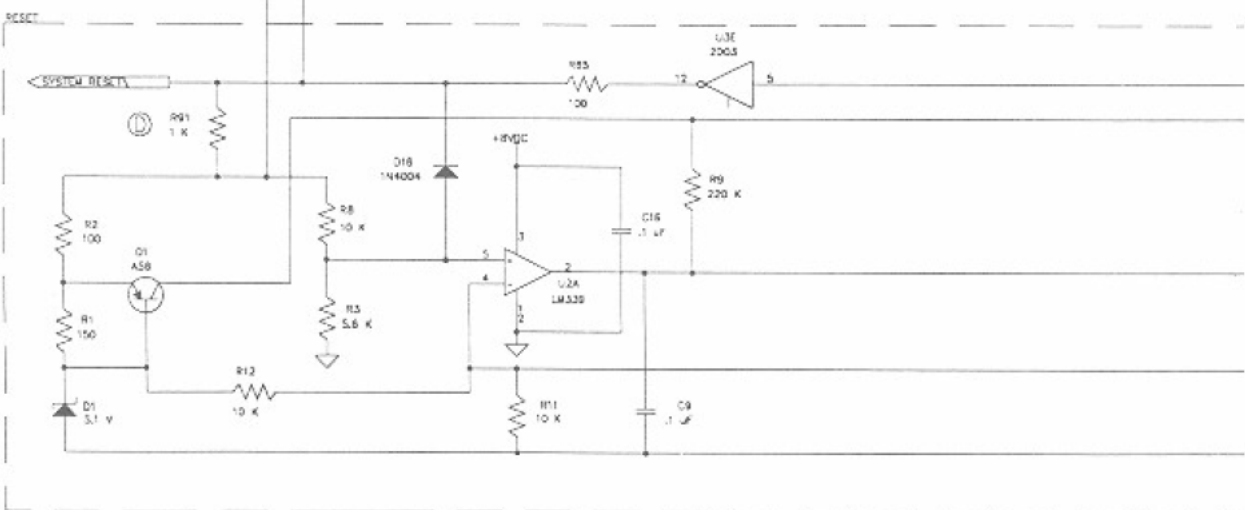
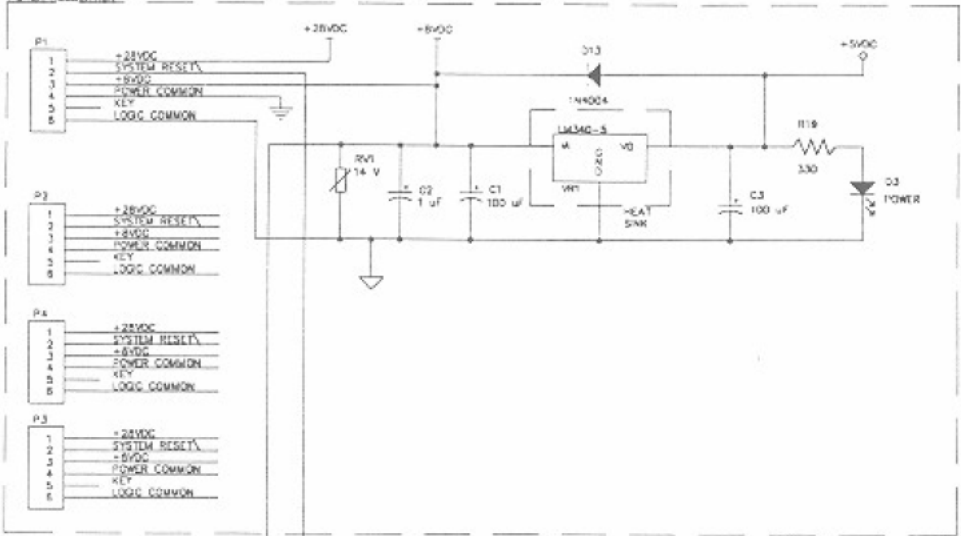
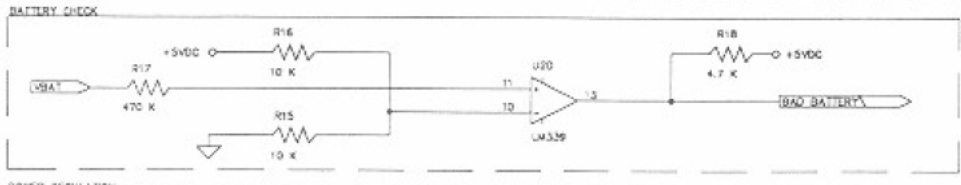
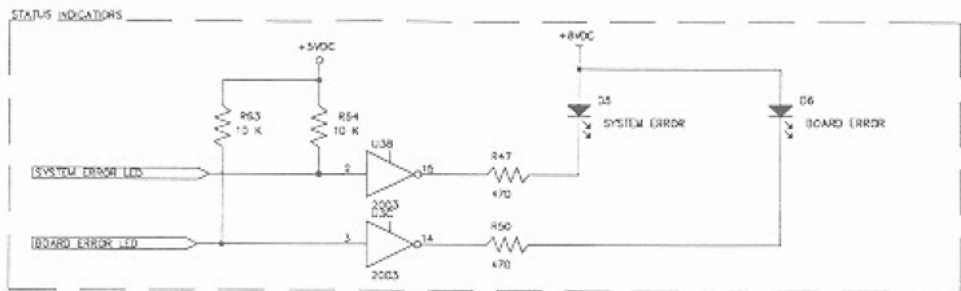

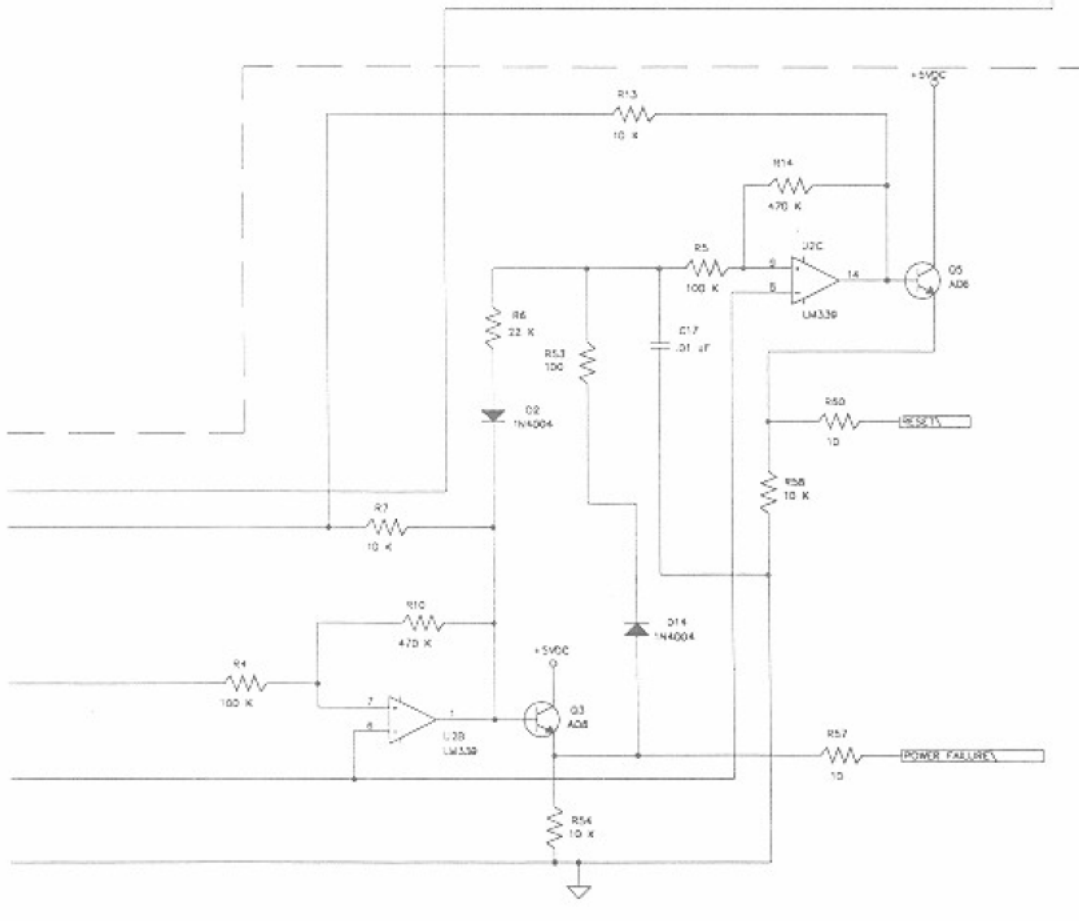
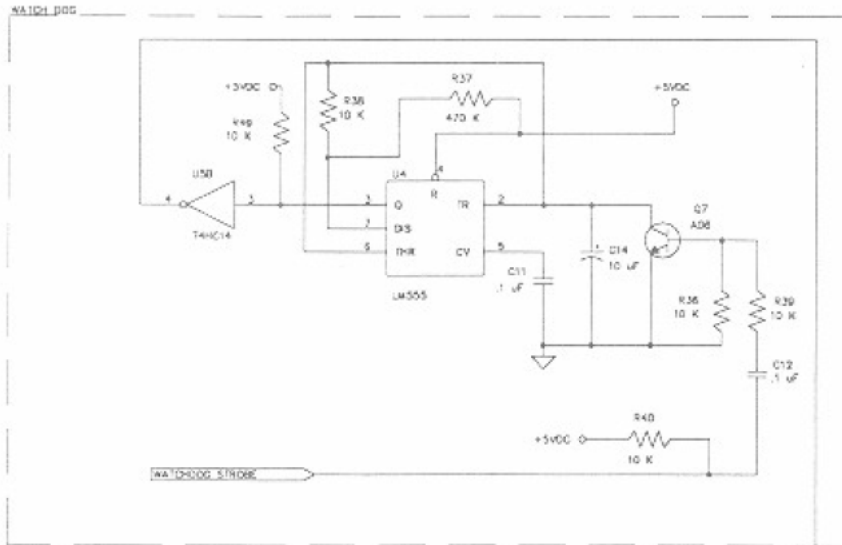

For Equivalent Engineering Drawing See 61031101-Q2 E

Figure 5-12A. Central Control Computer Schematic, Sheet 3

CD-100C C.C.C IC Power And Common Pin Chart

Ref.	Generic Part #	Power		Common	
		+5 VDC	+8 VDC	Logic	Power
U1	MAX232	16	—	15	—
U2	LM339	—	3	12	—
U3	2003	—	—	8	—
U4	LM555	8	—	1	—
U5	74HC14	14	—	7	—
U6	74LS374	20	—	10	—
U7	72421	16,17,18	—	9	—
U8	74HCT245	20	—	10	—
U9	74HC244	20	—	10	—
U10	74LS374	20	—	10	—
U11	74HCT244	20	—	10	—
U12	18P8_CDCCC	20	—	10	—
U13	DS8923	3	—	6	—
U14	6264/6256	28	—	14	—
U15	27512/27C101	32,30	—	16	—
U16	64180	32	—	1,33	—
U17	74HCT244	20	—	10	—
U18	74HCT244	20	—	10	—
U19	75176	8	—	5	—
U20	7417	14	—	7	—
U21	7417	14	—	7	—

For Equivalent Engineering Drawing See 61031101-Q2 E

Figure 5-12A. Central Control Computer Schematic, Sheet 4

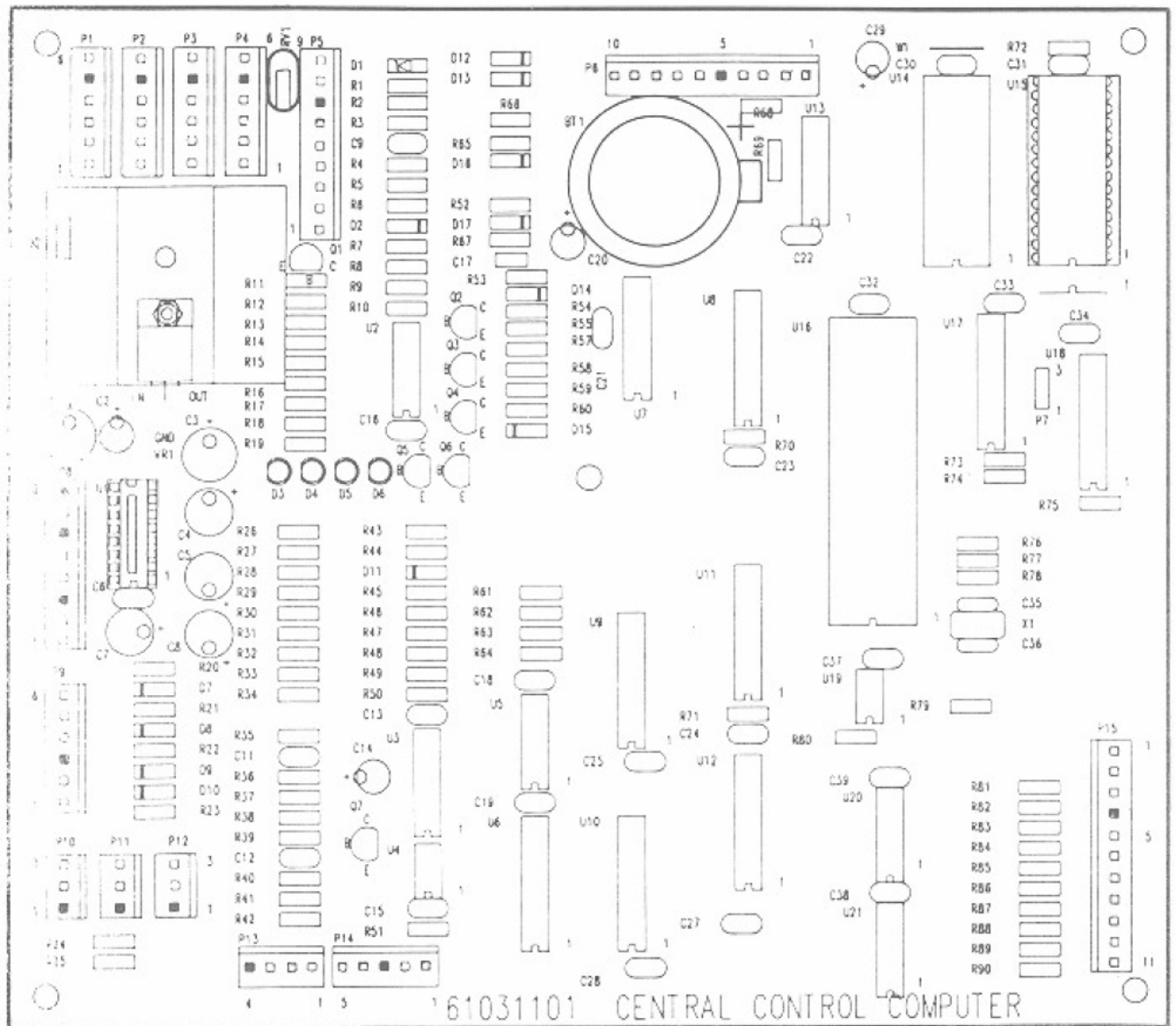

Figure 5-12B. Central Control Computer Circuit Board Layout

COMPONENT LIST FOR CENTRAL CONTROL COMPUTER (61031101-S)

BT1	Battery - Lithium	160 mah 3V (with holder)	30873101
		OR	
		750 mah 3V	40788901
C1	Capacitor - Electrolytic	100 MF	70023814
C2	Capacitor - Tantalum	1 MF	70025121
C3	Capacitor - Electrolytic	100 MF	70023814
C4	Capacitor - Electrolytic	10 MF	70023808
C5	Capacitor - Electrolytic	10 MF	70023808
C6	Capacitor - Monolithic Ceramic	.1 MF	70028511
C7	Capacitor - Electrolytic	10 MF	70023808
C8	Capacitor - Electrolytic	10 MF	70023808
C9	Capacitor - Monolithic Ceramic	.1 MF	70028511
C10	NOT USED		
C11	Capacitor - Monolithic Ceramic	.1 MF	70028511
C12	Capacitor - Monolithic Ceramic	.1 MF	70028511
C13	Capacitor - Monolithic Ceramic	.1 MF	70028511
C14	Capacitor - Electrolytic	10 MF	70023808
C15	Capacitor - Monolithic Ceramic	.1 MF	70028511
C16	Capacitor - Monolithic Ceramic	.1 MF	70028511
C17	Capacitor - Monolithic Ceramic	.01 MF	70028502
C18	Capacitor - Monolithic Ceramic	.1 MF	70028511
C19	Capacitor - Monolithic Ceramic	.1 MF	70028511
C20	Capacitor - Electrolytic	10 MF	70023808
C21	Capacitor - Monolithic Ceramic	.1 MF	70028511
C22	Capacitor - Monolithic Ceramic	.1 MF	70028511
C23	Capacitor - Monolithic Ceramic	.1 MF	70028511
C24	Capacitor - Monolithic Ceramic	.1 MF	70028511
C25	Capacitor - Monolithic Ceramic	.1 MF	70028511
C27	Capacitor - Monolithic Ceramic	.1 MF	70028511
C28	Capacitor - Monolithic Ceramic	.1 MF	70028511
C29	Capacitor - Electrolytic	10 MF	70023808
C30	Capacitor - Monolithic Ceramic	.1 MF	70028511
C31	Capacitor - Monolithic Ceramic	.1 MF	70028511
C32	Capacitor - Monolithic Ceramic	.1 MF	70028511
C33	Capacitor - Monolithic Ceramic	.1 MF	70028511
C34	Capacitor - Monolithic Ceramic	.1 MF	70028511
C35	Capacitor - Monolithic Ceramic	10 PF	70028701
C36	Capacitor - Monolithic Ceramic	10 PF	70028701
C37	Capacitor - Monolithic Ceramic	.1 MF	70028511
C38	Capacitor - Monolithic Ceramic	.1 MF	70028511
C39	Capacitor - Monolithic Ceramic	.1 MF	70028511
D1	Diode - Zener (5.1 V)		70035526
D2	Diode - Silicon	IN4004	70035005
D3	Diode - Light Emitting		70035305
D4	Diode - Light Emitting		70035305
D5	Diode - Light Emitting		70035305
D6	Diode - Light Emitting		70035305
D7	Diode - Silicon	IN4004	70035005
D8	Diode - Silicon	IN4004	70035005
D9	Diode - Silicon	IN4004	70035005
D10	Diode - Silicon	IN4004	70035005
D11	Diode - Silicon	IN4004	70035005

D12	Diode - Silicon	IN4004	70035005
D13	Diode - Silicon	IN4004	70035005
D14	Diode - Silicon	IN4004	70035005
D15	Diode - Silicon	IN4004	70035005
D16	Diode - Silicon	IN4004	70035005
D17	Diode - Germanium	IN270	70035101
P1	Wafer - Polarizing	6 CKT	70075006
P2	Wafer - Polarizing	6 CKT	70075006
P3	Wafer - Polarizing	6 CKT	70075006
P4	Wafer - Polarizing	6 CKT	70075006
P5	Wafer - Polarizing	9 CKT	70075009
P6	Wafer - Polarizing	10 CKT	70075010
P7	NOT USED		
P8	Wafer - Polarizing	8 CKT	70075008
P9	Wafer - Polarizing	6 CKT	70075006
P10	Wafer - Polarizing	3 CKT	70075003
P11	Wafer - Polarizing	3 CKT	70075003
P12	Wafer - Polarizing	3 CKT	70075003
P13	Wafer - Polarizing	4 CKT	70075004
P14	Wafer - Polarizing	5 CKT	70075005
P15	Wafer - Polarizing	11 CKT	70075011
Q1	Transistor - Silicon (PNP)		70030104
Q2	Transistor - Silicon (NPN)		70030008
Q3	Transistor - Silicon (NPN)		70030008
Q4	Transistor - Silicon (NPN)		70031301
Q5	Transistor - Silicon (NPN)		70030008
Q6	Transistor - Silicon (NPN)		70031301
Q7	Transistor - Silicon (NPN)		70030008

Note: All resistors are ¼ watt 5%, unless otherwise noted.

R1	Resistor - Carbon	150 Ω	79901151
R2	Resistor - Carbon	100 Ω	79901101
R3	Resistor - Carbon	5.6 K Ω (¼ W, 2%)	79902562
R4	Resistor - Carbon	100 K Ω	79901104
R5	Resistor - Carbon	100 K Ω	79901104
R6	Resistor - Carbon	22 K Ω	79901223
R7	Resistor - Carbon	10 K Ω	79901103
R8	Resistor - Carbon Film	10 K Ω (¼ W, 2%)	79902103
R9	Resistor - Carbon	220 K Ω	79901224
R10	Resistor - Carbon	470 K Ω	79901474
R11	Resistor - Carbon Film	10 K Ω (¼ W, 2%)	79902103
R12	Resistor - Carbon Film	10 K Ω (¼ W, 2%)	79902103
R13	Resistor - Carbon	10 K Ω	79901103
R14	Resistor - Carbon	470 K Ω	79901474
R15	Resistor - Carbon	10 K Ω	79901103
R16	Resistor - Carbon	10 K Ω	79901103
R17	Resistor - Carbon	470 K Ω	79901474
R18	Resistor - Carbon	4.7 K Ω	79901472
R19	Resistor - Carbon	330 Ω	79901331
R20	Resistor - Carbon	4.7 K Ω	79901472
R21	Resistor - Carbon	4.7 K Ω	79901472
R22	Resistor - Carbon	4.7 K Ω	79901472

COMPONENT LIST FOR CENTRAL CONTROL COMPUTER (61031101)

(Continued)

R25	Resistor - Carbon	10 K Ω	79901103
R26	Resistor - Carbon	47 K Ω	79901473
R27	Resistor - Carbon	47 K Ω	79901473
R28	Resistor - Carbon	47 K Ω	79901473
R29	Resistor - Carbon	47 K Ω	79901473
R30	Resistor - Carbon	47 K Ω	79901473
R31	Resistor - Carbon	47 K Ω	79901473
R32	Resistor - Carbon	47 K Ω	79901473
R33	Resistor - Carbon	1 K Ω	79901102
R34	Resistor - Carbon	1 K Ω	79901102
R35	Resistor - Carbon	47 K Ω	79901473
R36	Resistor - Carbon	10 K Ω	79901103
R37	Resistor - Carbon	470 K Ω	79901474
R38	Resistor - Carbon	10 K Ω	79901103
R39	Resistor - Carbon	10 K Ω	79901103
R40	Resistor - Carbon	10 K Ω	79901103
R41	Resistor - Carbon	1 K Ω	79901102
R42	Resistor - Carbon	47 K Ω	79901473
R43	Resistor - Carbon	1 K Ω	79901102
R44	Resistor - Carbon	10 K Ω	79901103
R45	Resistor - Carbon	1 K Ω	79901102
R46	Resistor - Carbon	10 K Ω	79901103
R47	Resistor - Carbon	470 Ω	79901471
R48	Resistor - Carbon	470 Ω	79901471
R49	Resistor - Carbon	10 K Ω	79901103
R50	Resistor - Carbon	470 Ω	79901471
R51	Resistor - Carbon	4.7 K Ω	79901472
R52	Resistor - Carbon	470 Ω	79901471
R53	Resistor - Carbon	100 Ω	79901101
R54	Resistor - Carbon	10 K Ω	79901103
R55	Resistor - Carbon	10 K Ω	79901103
R57	Resistor - Carbon	10 Ω	79901100
R58	Resistor - Carbon	10 K Ω	79901103
R59	Resistor - Carbon	10 K Ω	79901103
R60	Resistor - Carbon	10 Ω	79901100
R61	Resistor - Carbon	10 K Ω	79901103
R62	Resistor - Carbon	10 K Ω	79901103
R63	Resistor - Carbon	10 K Ω	79901103
R64	Resistor - Carbon	10 K Ω	79901103
R65	Resistor - Carbon	100 Ω	79901101
R66	Resistor - Carbon	1 K Ω	79901102
R67	Resistor - Carbon	22 K Ω	79901223
R68	Resistor - Carbon	100 Ω	79901101
R69	Resistor - Carbon	100 Ω	79901101
R70	Resistor - Carbon	1 K Ω	79901102
R71	Resistor - Carbon	1 K Ω	79901102
R72	Resistor - Carbon	1 K Ω	79901102
R73	Resistor - Carbon	22 K Ω	79901223
R74	Resistor - Carbon	1 K Ω	79901102
R75	Resistor - Carbon	1 K Ω	79901102
R76	Resistor - Carbon	1 K Ω	79901102
R77	Resistor - Carbon	1 K Ω	79901102
R78	Resistor - Carbon	1 K Ω	79901102
R79	Resistor - Carbon	1 K Ω	79901102
R80	Resistor - Carbon	10 K Ω	79901103

R81	Resistor - Carbon	4.7 K Ω	79901472
R82	Resistor - Carbon	4.7 K Ω	79901472
R83	NOT USED		
R84	Resistor - Carbon	4.7 K Ω	79901472
R85	Resistor - Carbon	4.7 K Ω	79901472
R86	Resistor - Carbon	4.7 K Ω	79901472
R87	Resistor - Carbon	4.7 K Ω	79901472
R88	Resistor - Carbon	4.7 K Ω	79901472
R89	Resistor - Carbon	4.7 K Ω	79901472
R90	Resistor - Carbon	4.7 K Ω	79901472
R91	Resistor - Carbon	1 K Ω	79901102
RV1	Metal Oxide Varistor	14 VDC	70037505 70037507
U1	NOT USED		
U2	I.C. - Quad Comparator (LM339)	(3302)	70036801
U3	I.C. - Darlington Array	(2003)	70036901
U4	I.C. - Timer	(LM555)	70033801
U5	I.C. - HCT (Hex Schmitt Trigger)	74HC14	79940014
U6	I.C. - Octal Edge Triggered F/F	74LS374	70037111
U7	I.C. - Calendar Clock	74HCT245	79930245
U9	I.C. - HC-Tristate Octal Buffer (Octal Bus Transceiver)	74HC244	79940244
U10	I.C. - Octal Edge Triggered F/F	74LS374	70037111
U11	I.C. - HCT (Octal Buffer/Line Driver)	74HCT244	79930244
U12	I.C. - PAL 18P8-CDCCC		30800232
U13	I.C. - RS-422 Dual Driver/Rcvr	DS8923	30800230
U14	I.C. - CMOS RAM 8K X 8	6264	70036604
U15	I.C. - 64K X 8 EPROM	27512	70039903
U16	I.C. - Microprocessor	64180	70039126
U17	I.C. - HCT (Octal Buffer/Line DRIVER)	74HCT244	79930244
U18	I.C. - HCT (octal Buffer/Line Driver)	74HCT244	79930244
U19	I.C. - Transceiver (RS-485)	75176	70037801
U20	I.C. - TTL Buffer (Open Collector)	7417	70036305
U21	I.C. - TTL Buffer (Open Collector)	7417	70036305
VR1	Regulator - Voltage (Linear I.C.)	LM340-5	70036505
W1	Not Used		
X1	Crystal - Quartz (12.288 Mhz)		25167314

The chart below shows the various combinations of strobes (outputs from the CCC) and returns (inputs to the CCC) and their corresponding functions.

Strobes 0 through 5 appear on Returns 0 through 3 when the indicated switches are activated.

For Example: If you need to be sure that Key 5 is working, find Key 5 in table 5-3. This matrix entry indicates that, when Strobe 3 is active and Key 5 is pressed, Return 1 becomes active.

Not all of the strobes and returns operate in this matrix mode; Returns 4 through 7 and Strobes 7 through 15 have unique functions, which are listed in the table.

Table 5-3. CD-100C CCC I/O Matrix

Outputs		Inputs							
Strobes	Dedicated	Returns				Dedicated			
		0	1	2	3	4	5	6	7
0		5¢ Coin Switch	10¢ Coin Switch	25¢ Coin Switch	50¢ Coin Switch	Cancel Switch	Display Attention	Service Switch	Low Battery Det.
1		Title Disp. Limit	Title Disp. Index	Reserved	UK Defaults				
2		Key 0	Key 1	Key 2	Key 3				
3		Key 4	Key 5	Key 6	Key 7				
4		Key 8	Key 9		Audit Report Start Button				
5		POPULAR	RESET	OUT	IN				
	6	Fade volume signal							
	7	Background music active							
	8	Display Reset - Controls hardware reset on the display driver chip							
	9	Sends speed info. to motor chip							
	10	Sends motor info. to motor chip							
	11	Mute							
	12	ROWELINK Tx/Rx Select							
	13	SYSTEM ERROR LED							
	14	BOARD ERROR LED							
	15	Watchdog Strobe							

This page intentionally left blank.

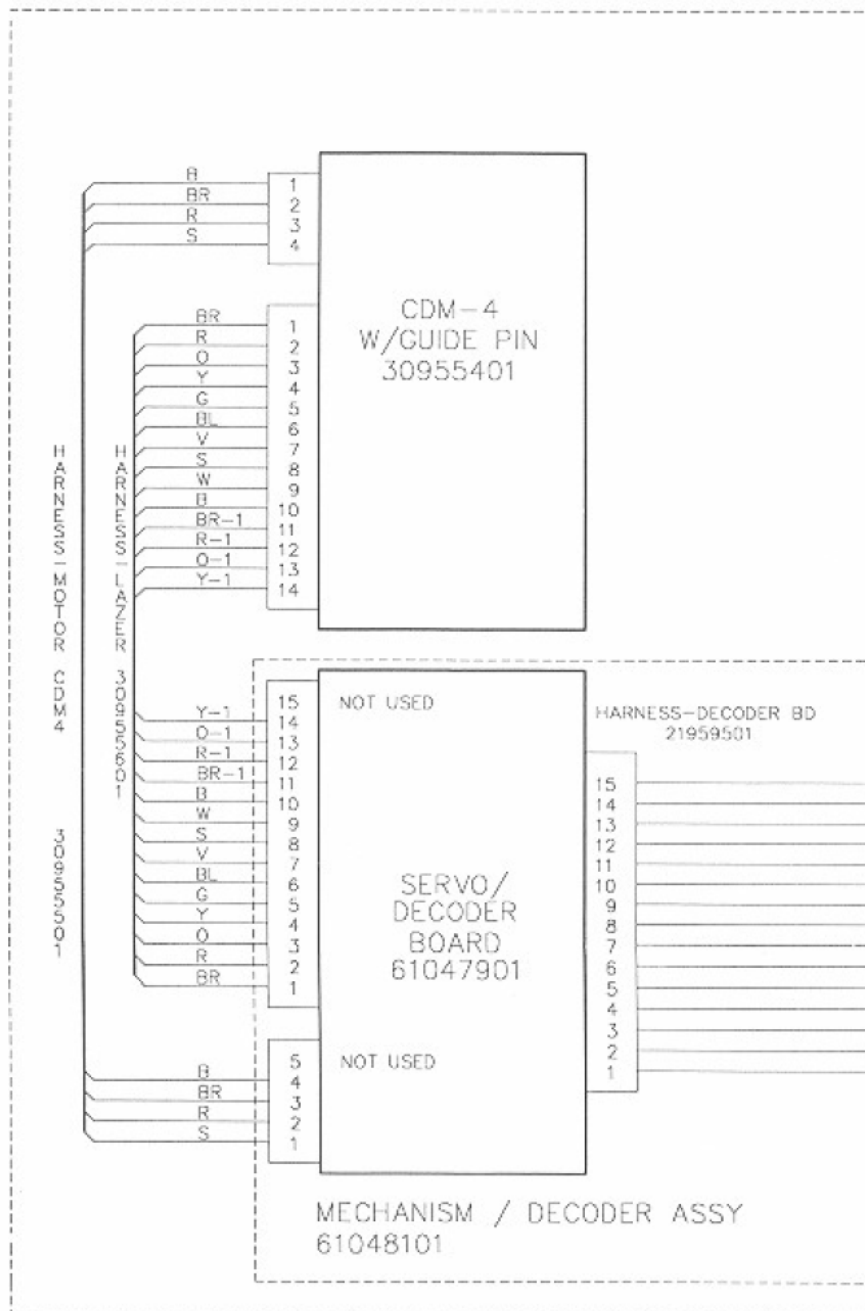

CD MECHANISM ASSEMBLY 61047801

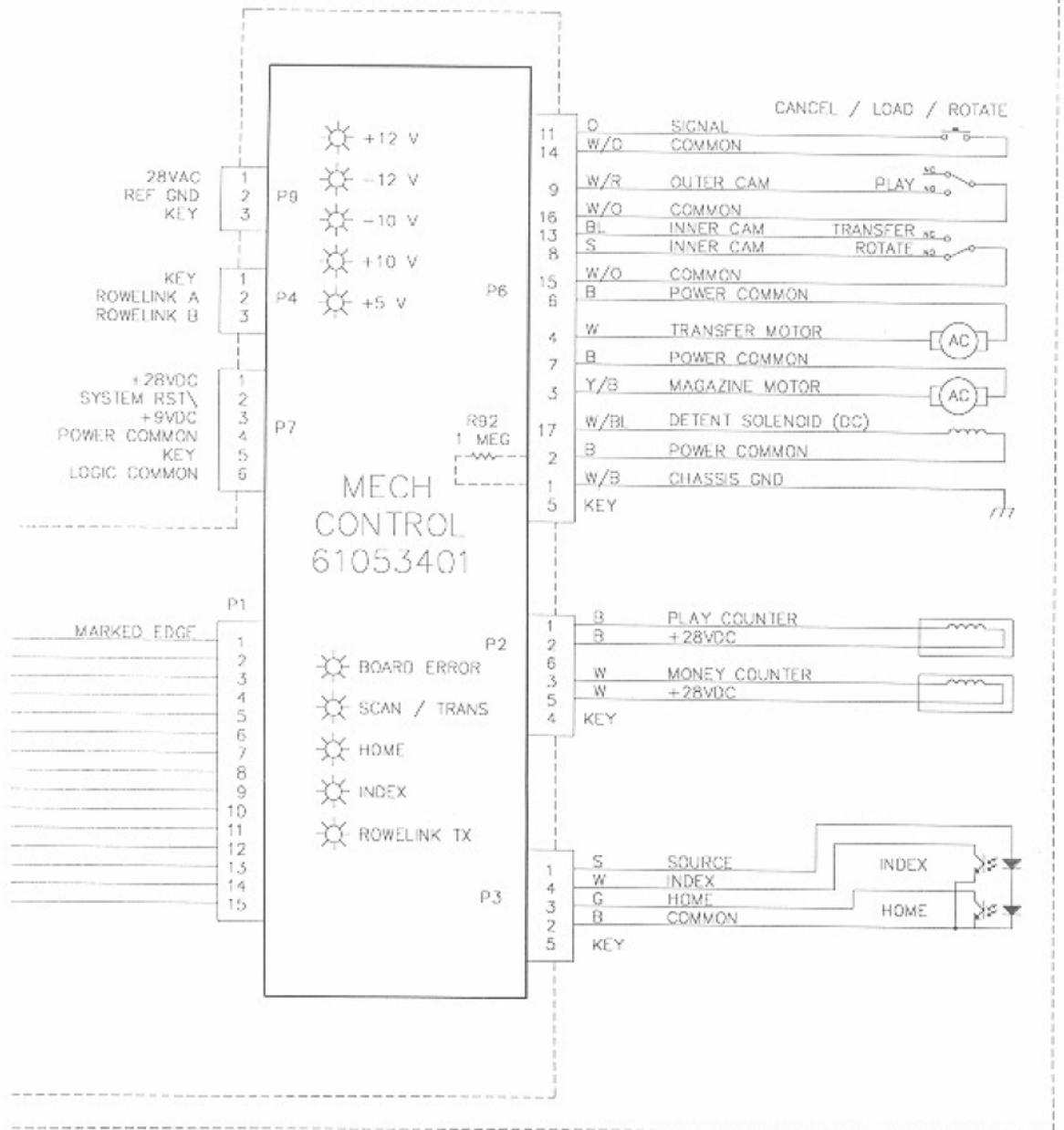

61047801-Q7 B
Figure 5-13A. Mechanism Control Assembly Block Diagram

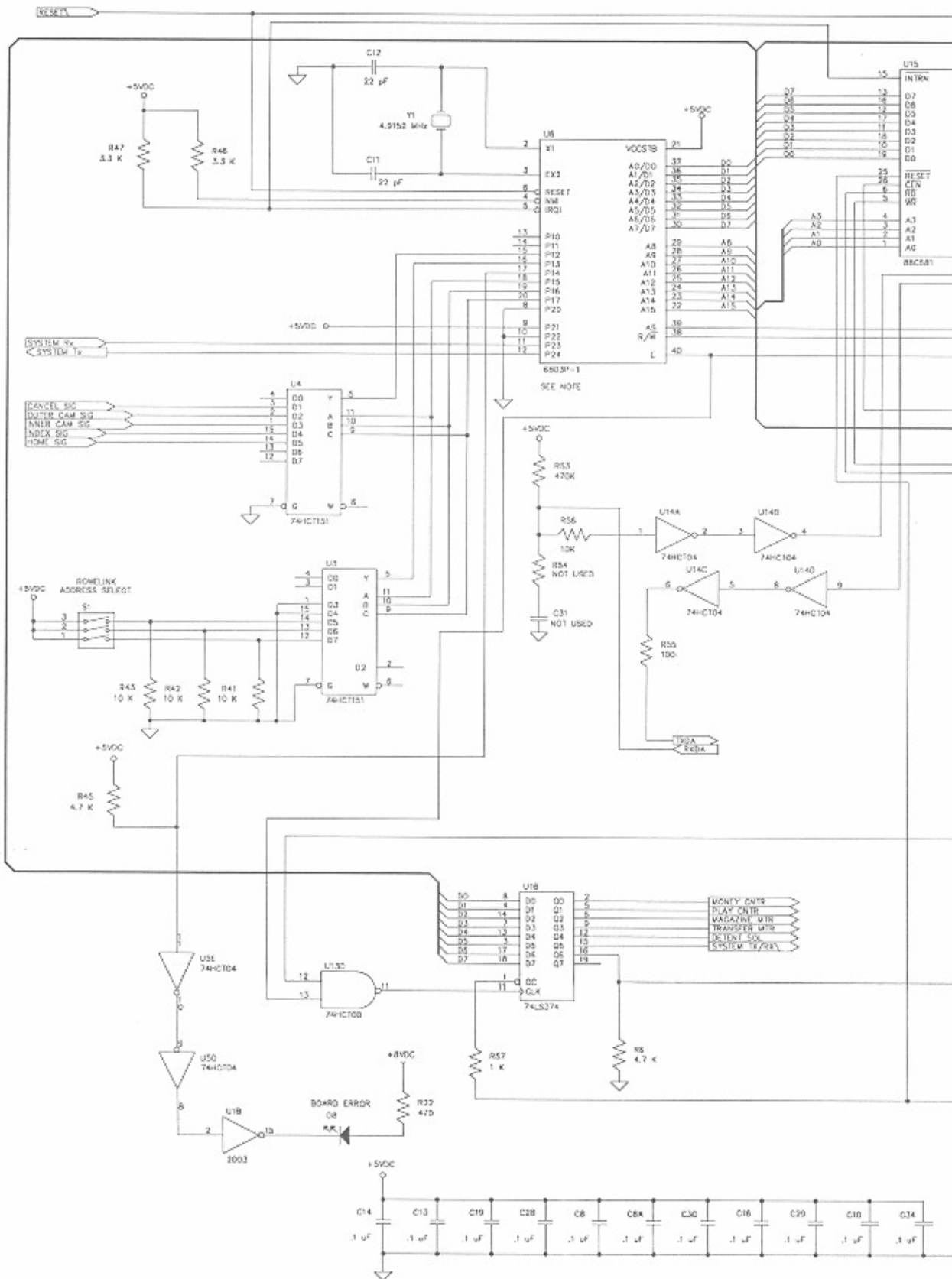

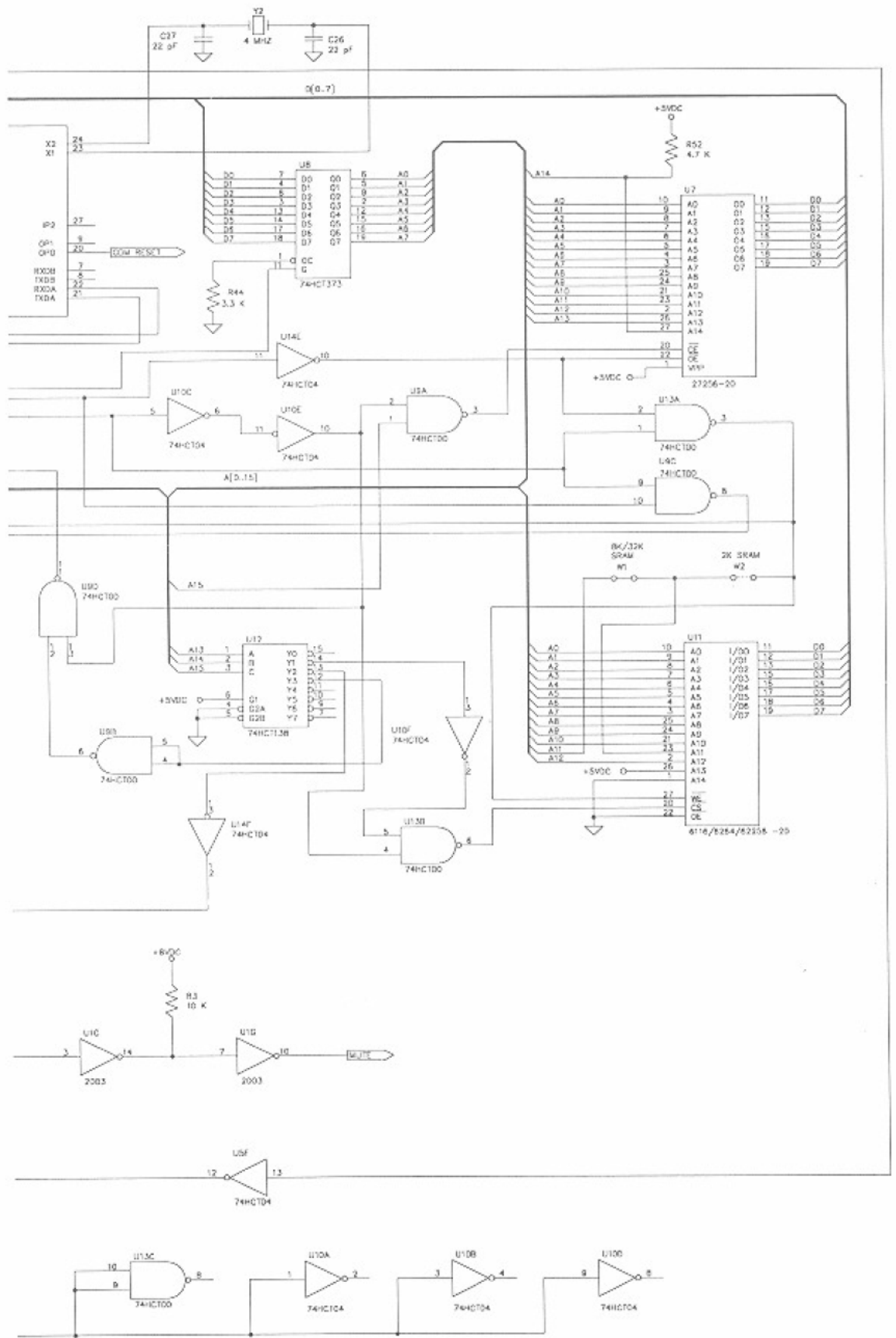

For Equivalent Engineering Drawing See 61053401-Q2 B

Figure 5-13B. Mechanism Control Assembly Schematic, Sheet 1

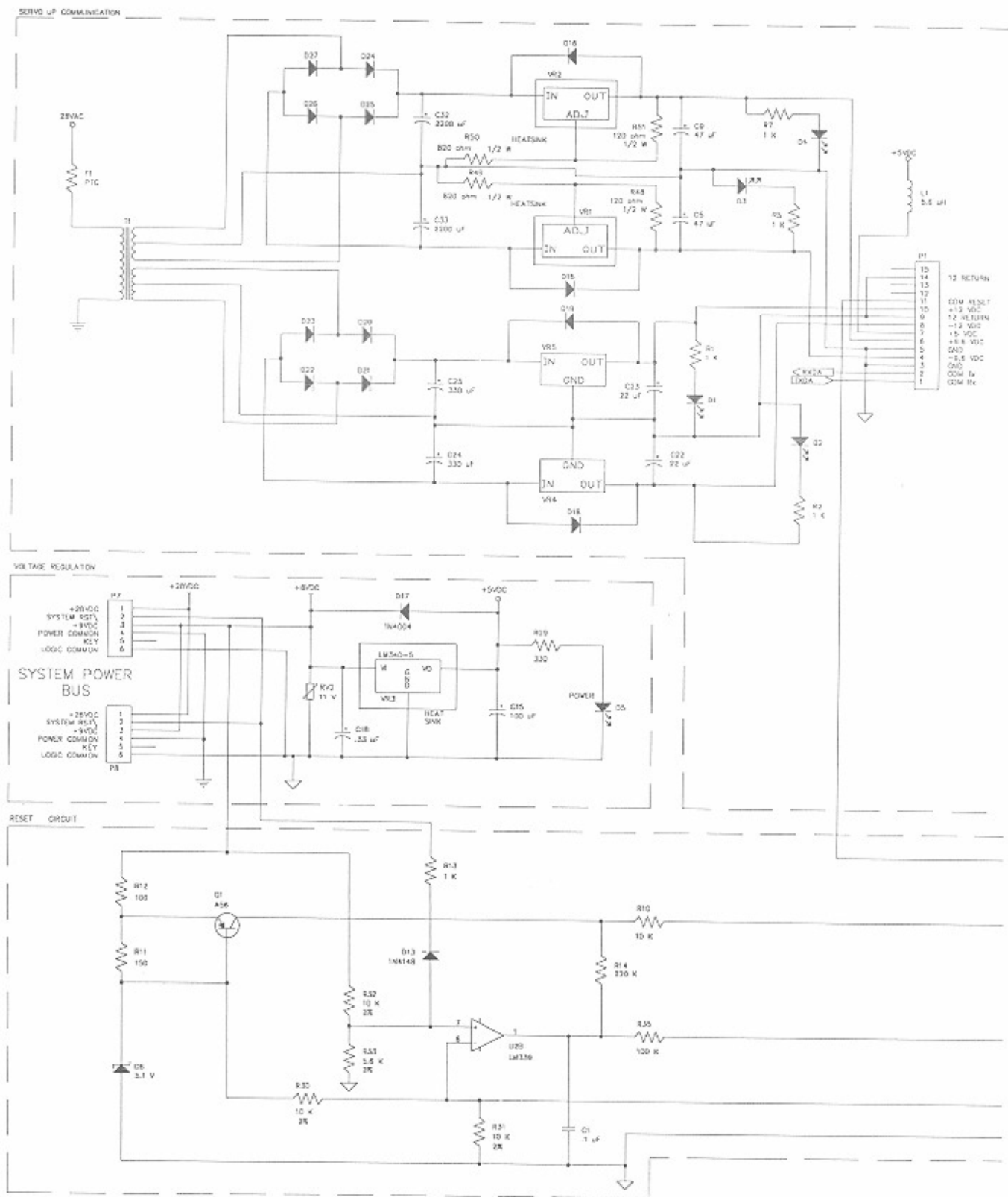

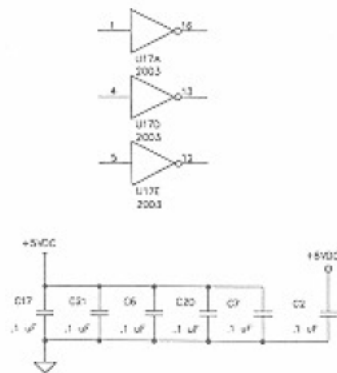
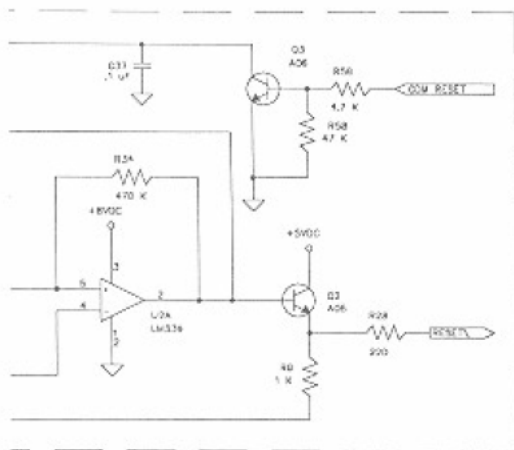
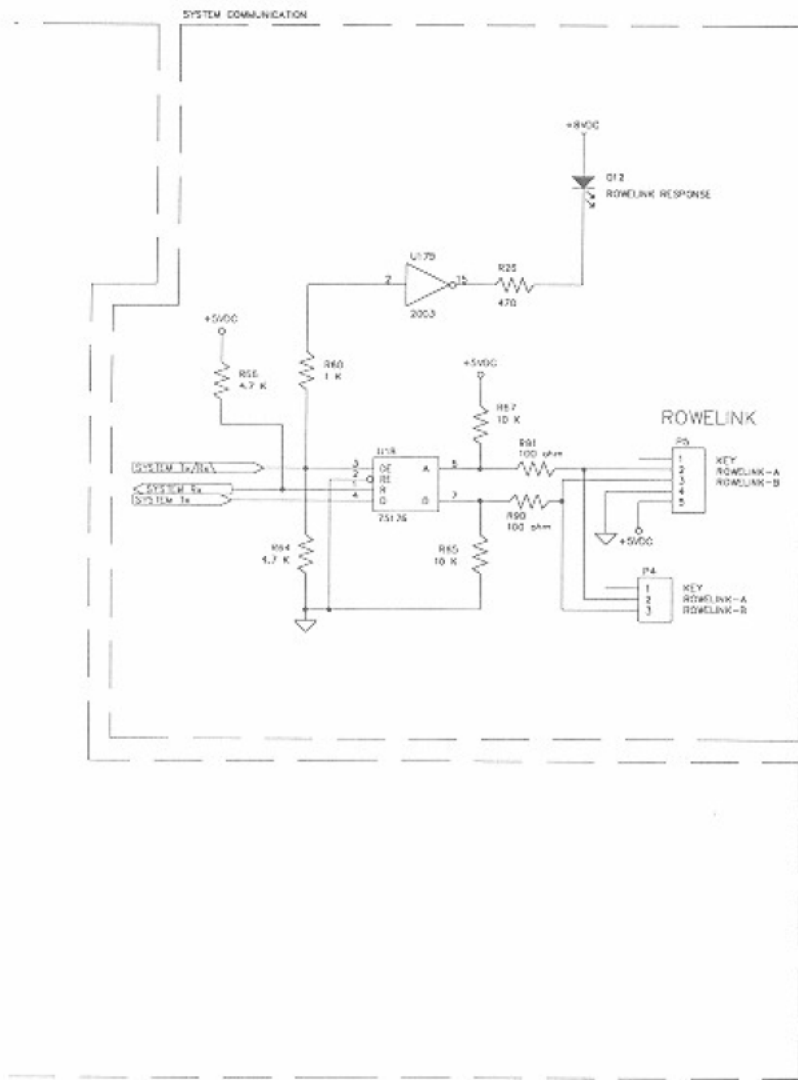

For Equivalent Engineering Drawing See 61053401-Q2 B

Figure 5-13B. Mechanism Control Assembly Schematic, Sheet 2

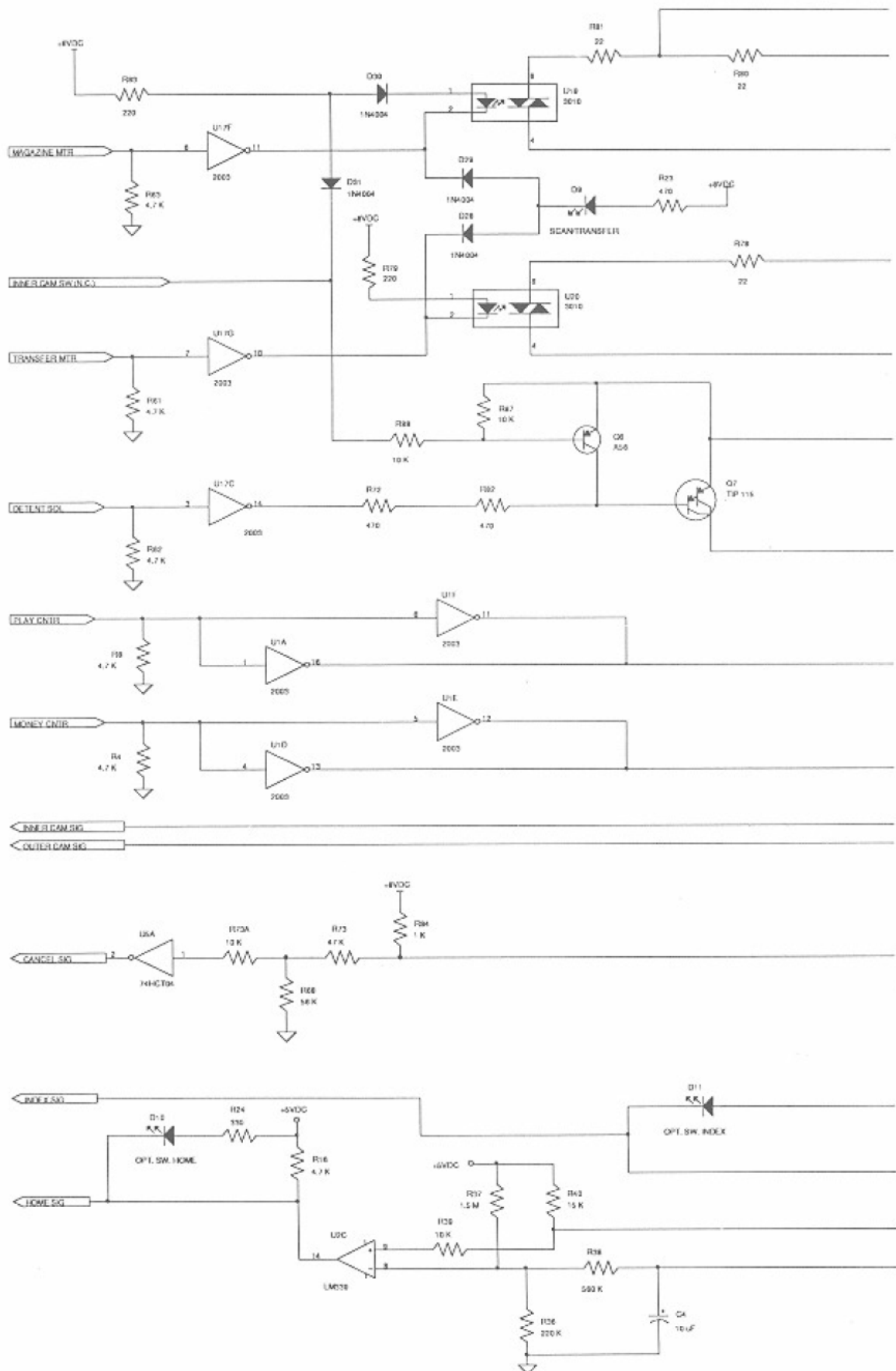

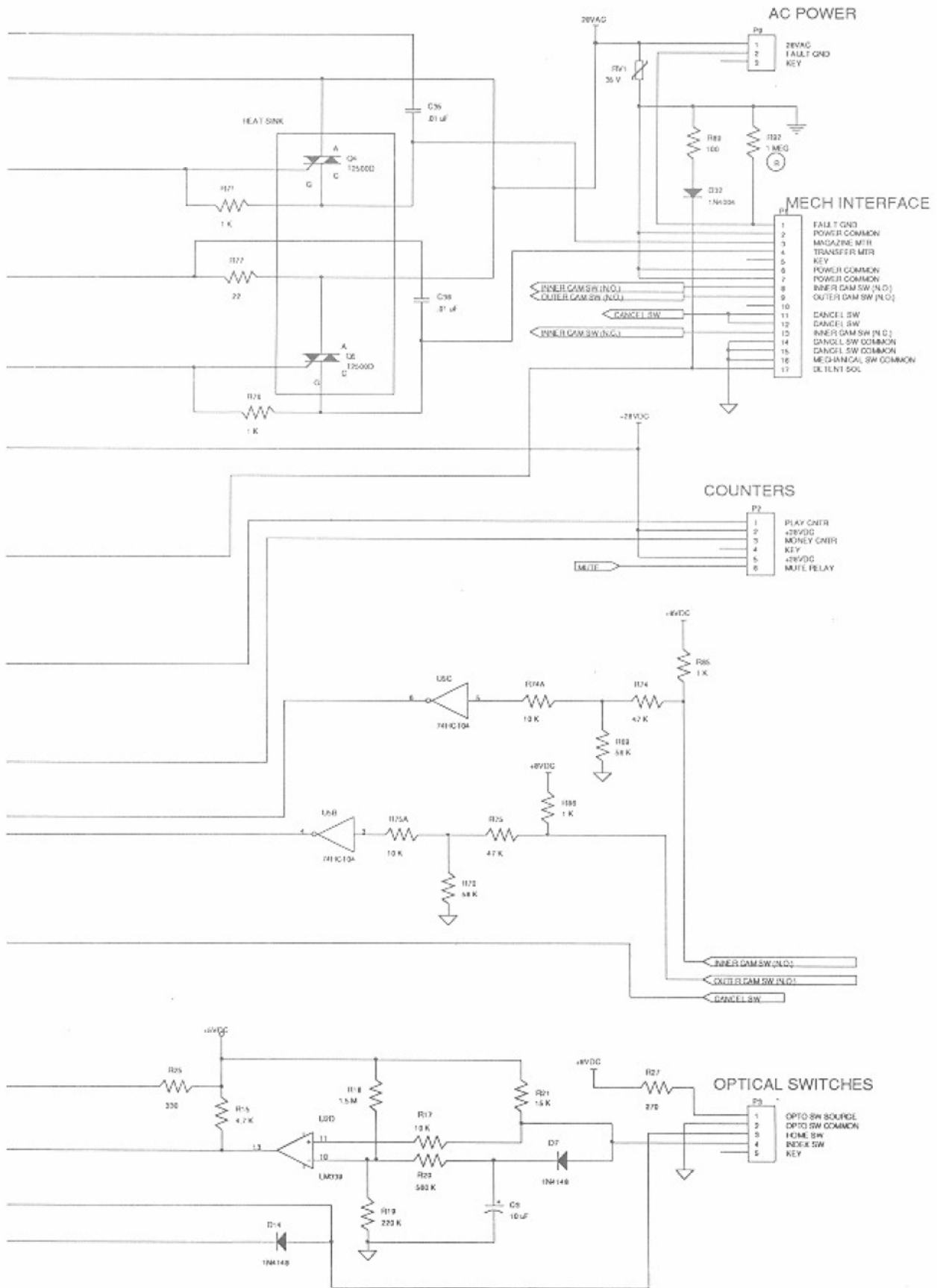

For Equivalent Engineering Drawing See 61053401-Q2 B

Figure 5-13B. Mechanism Control Assembly Schematic, Sheet 3

CD-100C Mech. Controller IC Power And Common Pin Chart

Ref.	Generic Part #	Power		Common	
		+5 VDC	+28 VDC	Logic	Power
U1	ULN2003	—	9	8	—
U2	LM3302	—	—	—	—
U3	74HCT151	16	—	8	—
U4	74HCT151	16	—	8	—
U5	74HCT04	14	—	7	—
U6	63A03R	7	—	1	—
U7	27256	28	—	14	—
U8	74HCT373	20	—	10	—
U9	74HCT00	14	—	7	—
U10	74HCT04	14	—	7	—
U11	6264	28	—	14	—
U12	74HCT138	16	—	8	—
U13	74HCT00	14	—	7	—
U14	74HCT04	14	—	7	—
U15	88C168	28	—	14	—
U16	74LS374	20	—	10	—
U17	ULN2003	—	—	8	—

For Equivalent Engineering Drawing See 61053401-Q2 B

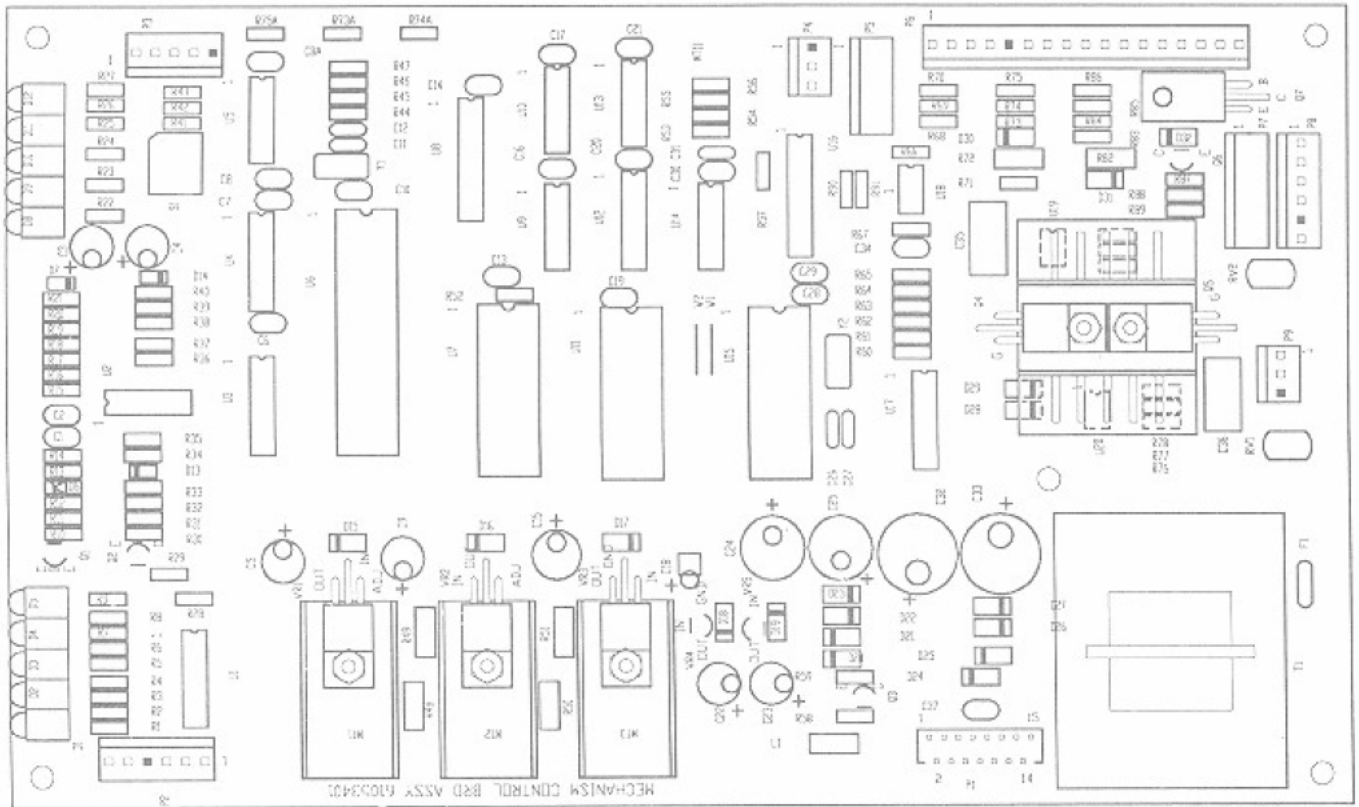

Figure 5-13C. Mechanism Control Assembly Circuit Board Layout 61053401-C

COMPONENT LIST FOR MECHANISM CONTROL BOARD (61053401-C)

C1	Capacitor - Monolythic Ceramic	.1 μ f	70028511
C2	Capacitor - Monolythic Ceramic	.1 μ f	70028511
C3	Capacitor - Electrolytic 50 VDC 20%	10 μ f	70028105
C4	Capacitor - Electrolytic 50 VDC 20%	10 μ f	70028105
C5	Capacitor - Electrolytic 35 VDC 20%	47 μ f	70028109
C6	Capacitor - Monolythic Ceramic	.1 μ f	70028511
C7	Capacitor - Monolythic Ceramic	.1 μ f	70028511
C8	Capacitor - Monolythic Ceramic	.1 μ f	70028511
C8A	Capacitor - Monolythic Ceramic	.1 μ f	70028511
C9	Capacitor - Electrolytic 35 VDC 20%	47 μ f	70028109
C10	Capacitor - Monolythic Ceramic	.1 μ f	70028511
C11	Capacitor - Monolythic Ceramic 10%	22 pf	70028705
C12	Capacitor - Monolythic Ceramic 10%	22 pf	70028705
C13	Capacitor - Monolythic Ceramic	.1 μ f	70028511
C14	Capacitor - Monolythic Ceramic	.1 μ f	70028511
C15	Capacitor - Electrolytic 16 VDC 20%	100 μ f	70028111
C16	Capacitor - Monolythic Ceramic	.1 μ f	70028511
C17	Capacitor - Monolythic Ceramic	.1 μ f	70028511
C18	Capacitor - Tantalum 35 VDC 20%	.33 μ f	70025119
C19	Capacitor - Monolythic Ceramic	.1 μ f	70028511
C20	Capacitor - Monolythic Ceramic	.1 μ f	70028511
C21	Capacitor - Monolythic Ceramic	.1 μ f	70028511
C22	Capacitor - Electrolytic 50 VDC 20%	22 μ f	70028107
C23	Capacitor - Electrolytic 50 VDC 20%	22 μ f	70028107
C24	Capacitor - Electrolytic 35 VDC 20%	330 μ f	70028114
C25	Capacitor - Electrolytic 35 VDC 20%	330 μ f	70028114
C26	Capacitor - Monolythic Ceramic 10%	22 pf	70028705
C27	Capacitor - Monolythic Ceramic 10%	22 pf	70028705
C28	Capacitor - Monolythic Ceramic	.1 μ f	70028511
C29	Capacitor - Monolythic Ceramic	.1 μ f	70028511
C30	Capacitor - Monolythic Ceramic	.1 μ f	70028511
C31	NOT USED		
C32	Capacitor - Electrolytic 35 VDC 20%	2200 μ f	70028116
C33	Capacitor - Electrolytic 35 VDC 20%	2200 μ f	70028116
C34	Capacitor - Monolythic Ceramic	.1 μ f	70028511
C35	Capacitor - Film 400 VDC 20%	.01 μ f	70024013
C36	Capacitor - Film 400 VDC 20%	.01 μ f	70024013
C37	Capacitor - Monolythic Ceramic	.1 μ f	70028511
D1	Diode - Light Emitting Red Diffused		70035201
D2	Diode - Light Emitting Red Diffused		70035201
D3	Diode - Light Emitting Red Diffused		70035201
D4	Diode - Light Emitting Red Diffused		70035201
D5	Diode - Light Emitting 90 Degree		70035201
D6	Diode - Zener 5.1V (1/2w, 5%)	1N5231B	70035526
D7	Diode - Silicon	1N4148	70035007
D8	Diode - Light Emitting 90 Degree		70035201
D9	Diode - Light Emitting 90 Degree		70035201
D10	Diode - Light Emitting 90 Degree		70035201
D11	Diode - Light Emitting 90 Degree		70035201
D12	Diode - Light Emitting 90 Degree		70035201
D13	Diode - Silicon	1N4148	70035007
D14	Diode - Silicon	1N4148	70035007
D15	Diode - Silicon	1N4004	70035005

D16	Diode - Silicon	1N4004	70035005
D17	Diode - Silicon	1N4004	70035005
D18	Diode - Silicon	1N4004	70035005
D19	Diode - Silicon	1N4004	70035005
D20	Diode - Silicon	1N4004	70035005
D21	Diode - Silicon	1N4004	70035005
D22	Diode - Silicon	1N4004	70035005
D23	Diode - Silicon	1N4004	70035005
D24	Diode - Silicon	1N4004	70035005
D25	Diode - Silicon	1N4004	70035005
D26	Diode - Silicon	1N4004	70035005
D27	Diode - Silicon	1N4004	70035005
D28	Diode - Silicon	1N4004	70035005
D29	Diode - Silicon	1N4004	70035005
D30	Diode - Silicon	1N4004	70035005
D31	Diode - Silicon	1N4004	70035005
D32	Diode - Silicon	1N4004	70035005
F1	Resistor - PTC		70072501
L1	Inductor - RF	5.6 μ H	70041503
P1	Connector - Ribbon Cable 1.5 mm		21640901
P2	Header - Polarized .156 6 Position		70075006
P3	Header - Polarized .156 5 Position		70075005
P4	Header - Polarized .156 3 Position		70075003
P5	NOT USED		
P6	Header - Polarized .156 17 Position		70075017
P7	NOT USED		
P8	Header - Polarized .156 6 Position		70075006
P9	Header - Polarized .156 3 Position		70075003
Q1	Transistor - Silicon PNP	MPSA56	70030104
Q2	Transistor - Silicon NPN	MPSA06	70030008
Q3	Transistor - Silicon NPN	MPSA06	70030008
Q4	Thyristor Triac	T2500D	70038102
Q5	Thyristor Triac	T2500D	70038102
Q6	Transistor - Silicon PNP	MPSA56	70030104
Q7	Transistor - Silicon Darlington	TIP115	70030805

Note: All resistors are ¼ watt 5%, unless otherwise noted.

R1	Resistor	1 K	79901102
R2	Resistor	1 K	79901102
R3	Resistor	10 K	79901103
R4	Resistor	4.7 K	79901472
R5	Resistor	1 K	79901102
R6	Resistor	4.7 K	79901472
R7	Resistor	1 K	79901102
R8	Resistor	4.7 K	79901472
R9	Resistor	1 K	79901102
R10	Resistor	10 K	79901103

COMPONENT LIST FOR MECHANISM CONTROL BOARD

R11	Resistor	150 Ω	79901151
R12	Resistor	100 Ω	79901101
R13	Resistor	1 K	79901102
R14	Resistor	220 K	79901224
R15	Resistor	4.7 K	79901472
R16	Resistor	4.7 K	79901472
R17	Resistor	10 K	79901103
R18	Resistor	1.5 M	79901155
R19	Resistor	220 K	79901224
R20	Resistor	560 K	79901564
R21	Resistor	15 K	79901153
R22	Resistor	470 Ω	79901471
R23	Resistor	470 Ω	79901471
R24	Resistor	330 Ω	79901331
R25	Resistor	330 Ω	79901331
R26	Resistor	470 Ω	79901471
R27	Resistor	270 Ω	79901271
R28	Resistor	220 Ω	79901221
R29	Resistor	330 Ω	79901331
R30	Resistor - Carbon Film	10 K ($\frac{1}{4}w$, 2%)	79902103
R31	Resistor - Carbon Film	10 K ($\frac{1}{4}w$, 2%)	79902103
R32	Resistor - Carbon Film	10 K ($\frac{1}{4}w$, 2%)	79902103
R33	Resistor - Carbon Film	5.6 K ($\frac{1}{4}w$, 2%)	79902562
R34	Resistor	470 K	79901474
R35	Resistor	100 K	79901104
R36	Resistor	220 K	79901224
R37	Resistor	1.5 M	79901155
R38	Resistor	560 K	79901564
R39	Resistor	10 K	79901103
R40	Resistor	15 K	79901153
R41	Resistor	10 K	79901103
R42	Resistor	10 K	79901103
R43	Resistor	10 K	79901103
R44	Resistor	3.3 K	79901332
R45	Resistor	4.7 K	79901472
R46	Resistor	3.3 K	79901332
R47	Resistor	3.3 K	79901332
R48	Resistor - Metal Film	120 Ω ($\frac{1}{2}w$, 5%)	79904121
R49	Resistor - Metal Film	820 Ω ($\frac{1}{2}w$, 5%)	79904821
R50	Resistor - Metal Film	820 Ω ($\frac{1}{2}w$, 5%)	79904821
R51	Resistor - Metal Film	120 Ω ($\frac{1}{2}w$, 5%)	79904121
R52	Resistor	4.7 K	79901472
R53	Resistor	470 K	79901474
R54	NOT USED		
R55	Resistor	100 Ω	79901101
R56	Resistor	10 K	79901103
R57	Resistor	1 K	79901102
R58	Resistor	47 K	79901473
R59	Resistor	4.7 K	79901472
R60	Resistor	1 K	79901102
R61	Resistor	4.7 K	79901472
R62	Resistor	4.7 K	79901472
R63	Resistor	4.7 K	79901472
R64	Resistor	4.7 K	79901472
R65	Resistor	10 K	79901103

R66	Resistor	4.7 K	79901472
R67	Resistor	10 K	79901103
R68	Resistor	56 K	79901563
R69	Resistor	56 K	79901563
R70	Resistor	56 K	79901563
R71	Resistor	1 K	79901102
R72	Resistor - Metal Film	470 Ω (1/2w, 5%)	79904471
R73	Resistor	47 K	79901473
R73A	Resistor	10 K	79901103
R74	Resistor	47 K	79901473
R74A	Resistor	10 K	79901103
R75	Resistor	47 K	79901473
R75A	Resistor	10 K	79901103
R76	Resistor	1 K	79901102
R77	Resistor	22 Ω	79901220
R78	Resistor	22 Ω	79901220
R79	Resistor	220 Ω	79901221
R80	Resistor	22 Ω	79901220
R81	Resistor	22 Ω	79901220
R82	Resistor - Metal Film	470 Ω (1/2w, 5%)	79904471
R83	Resistor	220 Ω	79901221
R84	Resistor	1 K	79901102
R85	Resistor	1 K	79901102
R86	Resistor	1 K	79901102
R87	Resistor	10 K	79901103
R88	Resistor	10 K	79901103
R89	Resistor	100 Ω	79901101
R90	Resistor	100 Ω	79901101
R91	Resistor	100 Ω	79901101
RV1	Metal Oxide Varistor 45 VDC		70037506
RV2	Metal Oxide Varistor 14 VDC		70037505
S1	NOT USED		
T1	Transformer		40827201
U1	I.C. - Darlington Array	(ULN2003)	70036901
U2	I.C. - Quad Comparator	(LM3302)	70036801
U3	I.C. - 1 Of 8 Multiplexer	(74HCT151)	79930151
U4	I.C. - 1 Of 8 Multiplexer	(74HCT151)	79930151
U5	I.C. - Hex Inverter	(74HCT04)	79930004
U6	I.C. - Microprocessor	(63A03R) (6803P-1)	70039125 70039128
U7	I.C. - 32K X 8 EPROM (CD100 MECH V3.0)	(27256)	70038322
U8	I.C. - Octal Transparent Latch	(74HCT373)	79930373
U9	I.C. - Quad 2 Input NAND Gate	(74HCT00)	79930000
U10	I.C. - Hex Inverter	(74HCT04)	79930004
U11	I.C. - 8K X 8 CMOS RAM		70036604
U12	I.C. - 1 Of 8 Decoder	(74HCT138)	79930138
U13	I.C. - Quad 2 Input NAND Gate	(74HCT00)	79930000
U14	I.C. - Hex Inverter	(74HCT04)	79930004
U15	I.C. - Dual USART	(88C168)	30800255
U16	I.C. - Octal Edge-triggered Flip Flop	(74LS374)	70037111
U17	I.C. - Darlington Array	(ULN2003)	70036901

COMPONENT LIST FOR MECHANISM CONTROL BOARD

U18	I.C. - Transceiver RS-485	(75176)	70037801
U19	Photocoupler Opto-triac	(3010)	70033703
U20	Photocoupler Opto-triac	(3010)	70033703
VR1	I.C. - Voltage Regulator Adjustable	(LM337T)	70036508
VR2	I.C. - Voltage Regulator Adjustable	(LM317T)	70036507
VR3	I.C. - Voltage Regulator + 5V	(LM340T5)	70036505
VR4	I.C. - Voltage Regulator -12V	(LM79L12)	70036517
VR5	I.C. - Voltage Regulator +12V	(LM78L12)	70036516
W1	Wire - Bare		00503200
W2	NOT USED		
Y1	Crystal - Quartz 4.9152 MHz		25167313
Y2	Crystal - Quartz 4.000 MHz		25167306

This page intentionally left blank.

P3
 CCC STROBE/RETURN

RET2 KEY2,6,OUT,LMSW C	1
RET3 KEY3,7,IN	2
RET1 KEY1,5,9,RST,LMSW B	3
RET0 KEY0,4,8,MP,LMSW A	4
STR2 KEY 0-3	5
STR3 KEY 4-7	6
STR4 KEY 8,9	7
STR5 KEY MP,RST,OUT,IN	8
STR1 LMT SW A,B,C	9
KEY	10
STR9 TITLE MOTOR ENABLE	11
STR10 TITLE MOTOR DIR	12

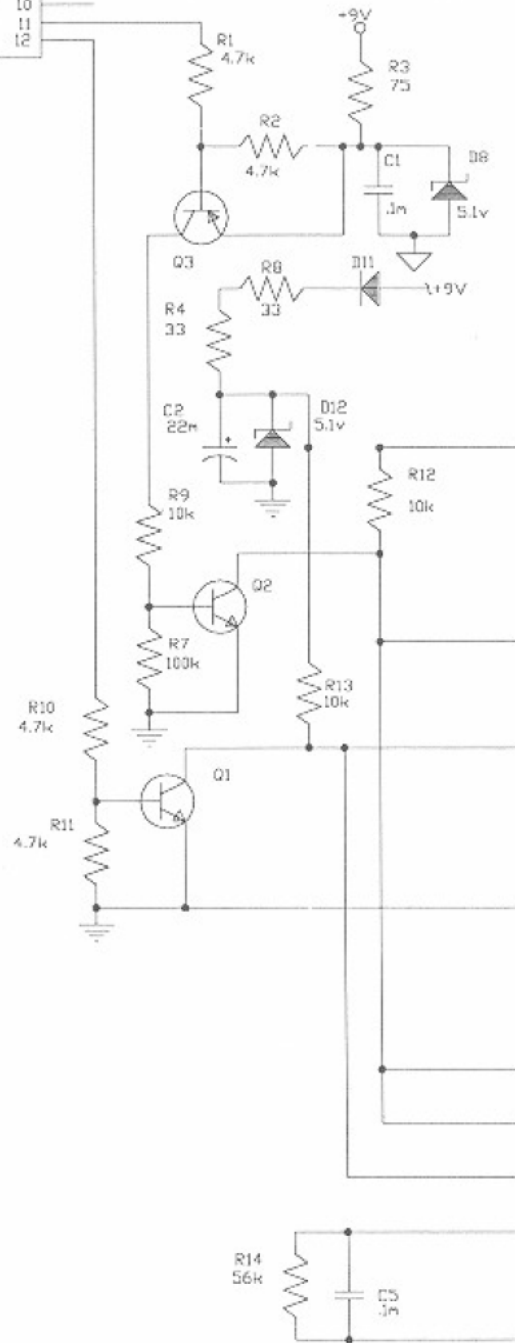
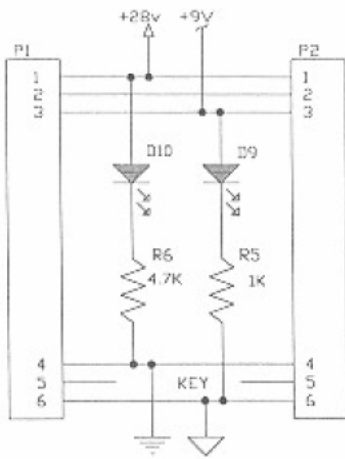

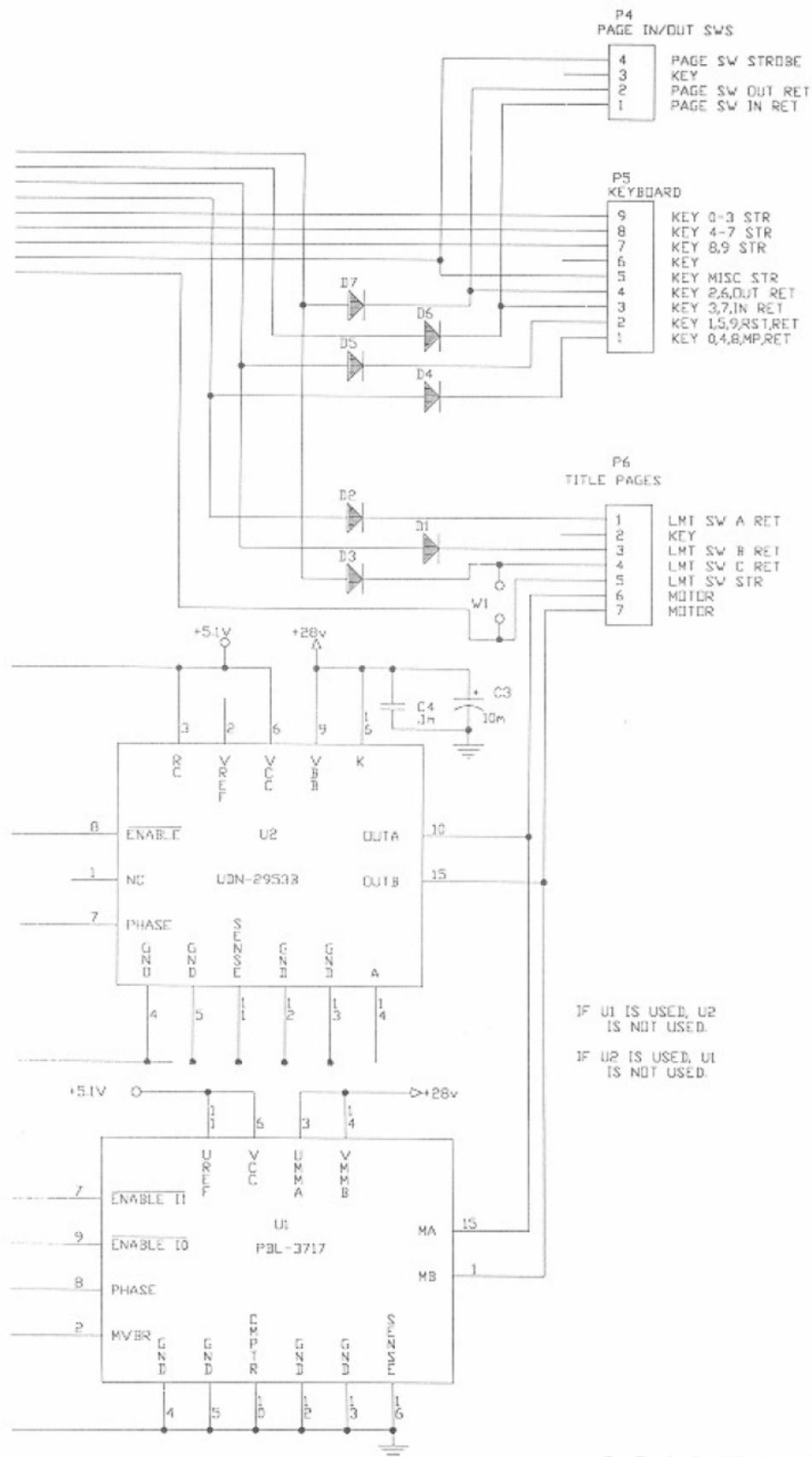

For Equivalent Engineering Drawing See 40853001-Q2 A Figure 5-14A. Title Rack Interface Schematic

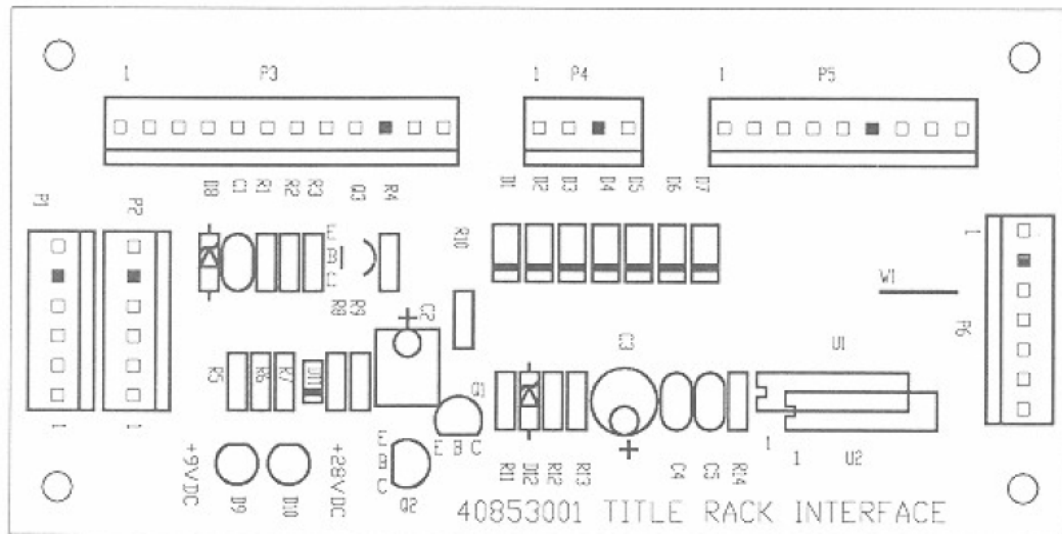

Figure 5-14B. Title Rack Interface Circuit Board Layout 40853001 - A

COMPONENT LIST FOR TITLE RACK INTERFACE BOARD (40853001-A)

C1	CAPACITOR - MONOLYTHIC CERAMIC	.1 UF	70028511
C2	CAPACITOR - TANTALUM 15 VDC 10%	22 UF	70025104
C3	CAPACITOR - ELECTROLYTIC 50 VDC 20%	10 UF	70023808
C4	CAPACITOR - MONOLYTHIC CERAMIC	.1 UF	70028511
C5	CAPACITOR - MONOLYTHIC CERAMIC	.1 UF	70028511
D1	DIODE - SILICON	1N4004	70035005
D2	DIODE - SILICON	1N4004	70035005
D3	DIODE - SILICON	1N4004	70035005
D4	DIODE - SILICON	1N4004	70035005
D5	DIODE - SILICON	1N4004	70035005
D6	DIODE - SILICON	1N4004	70035005
D7	DIODE - SILICON	1N4004	70035005
D8	DIODE - ZENER 5.1V 1/2W 5%	1N5231B	70035526
D9	DIODE - LIGHT EMITTING RED DIFFUSED		70035305
D10	DIODE - LIGHT EMITTING RED DIFFUSED		70035305
D11	DIODE - SILICON	1N4148	70035012
D12	DIODE - ZENER 5.1V 1/2W 5%	1N5231B	70035526
P1	HEADER - POLARIZED .156 6 POSITION		70075006
P2	HEADER - POLARIZED .156 6 POSITION		70075006
P3	HEADER - POLARIZED .156 12 POSITION		70075012
P4	HEADER - POLARIZED .156 4 POSITION		70075004
P5	HEADER - POLARIZED .156 9 POSITION		70075009
P6	HEADER - POLARIZED .156 7 POSITION		70075007
Q1	TRANSISTOR - SILICON NPN	MPSA06	70030008
Q2	TRANSISTOR - SILICON NPN	MPSA06	70030008
Q3	TRANSISTOR - SILICON PNP	MPSA56	70030104
R1	RESISTOR - CARBON FILM 1/4W 5%	4.7 K	79901472
R2	RESISTOR - CARBON FILM 1/4W 5%	4.7 K	79901472
R3	RESISTOR - CARBON FILM 1/4W 5%	75 OHM	79901750
R4	RESISTOR - CARBON FILM 1/4W 5%	33 OHM	79901330
R5	RESISTOR - CARBON FILM 1/4W 5%	1 K	79901102
R6	RESISTOR - CARBON FILM 1/4W 5%	4.7 K	79901472
R7	RESISTOR - CARBON FILM 1/4W 5%	100 K	79901104
R8	RESISTOR - CARBON FILM 1/4W 5%	33 OHM	79901330
R9	RESISTOR - CARBON FILM 1/4W 5%	10 K	79901103
R10	RESISTOR - CARBON FILM 1/4W 5%	4.7 K	79901472
R11	RESISTOR - CARBON FILM 1/4W 5%	4.7 K	79901472
R12	RESISTOR - CARBON FILM 1/4W 5%	10 K	79901103
R13	RESISTOR - CARBON FILM 1/4W 5%	10 K	79901103
R14	RESISTOR - CARBON FILM 1/4W 5%	56 K	79901563
U1	I.C. - MOTOR DRIVER	CS3717A	30800241 SEE NOTE
U2	I.C. - MOTOR DRIVER	UDN-2953B	30800229 SEE NOTE
W1	NOT USED		

NOTE: IF U1 IS USED, U2 IS NOT USED
IF U2 IS USED, U1 IS NOT USED

This page intentionally left blank.

Section 6: Mechanical Adjustments

LUBRICATION

Your phonograph mechanism requires no lubrication.

UNSCHEDULED MAINTENANCE

This section contains adjustments, removal, and replacement procedures that are to be followed whenever a malfunction has occurred.

MECHANISM MAINTENANCE AND ADJUSTMENTS



CAUTION:

The CD mechanism is extremely sensitive to static discharges. The photo diodes and the laser are more sensitive to discharges than MOS IC's. Careless handling may immediately destroy components within the player or cause undetectable damage that will lead to failure after several weeks or even months of use. Before you touch the player, discharge your hands and tools by touching a grounded metal part of the phonograph, such as the amplifier or power supply chassis. If you need to remove the CD player for servicing, place the CD player into the anti-static bag (shipped with the phonograph for this purpose) immediately after you remove it from the phonograph.

CD Player Mechanism

The only maintenance required on the CD player is an occasional cleaning of the lens. If you need to clean the CD player lens, be sure to follow the lens cleaning procedure that follows.

Cleaning The Laser Lens



NOTE:

Before you clean the laser lens, be sure to turn the jukebox power OFF and ground yourself by touching a grounded component (such as the lower door) to discharge any static buildup that may harm the CDM-4 player.

1. Remove loose particles from the lens by gently brushing it with a camel's hair brush or a blow brush (both items can be purchased at most camera supply stores). Take care not to snag brush bristles under the lens. The lens is mounted on a delicate suspension spring that may be damaged with even a soft brush.
2. Remove any remaining dirt by placing one to three drops of Kodak Lens Cleaner (Kodak Catalog Number 176 7136, available from photographic supply stores or Rowe Part Number 21966601) on a lint-free "Q"-Tip and very gently wiping dust and smoke deposits from the lens. Take care not to damage the delicate lens suspension spring. Do not allow any of the lens cleaner to run down the side of the lens.

CD Player Maintenance

The CD player does not require any adjustments or field replaceable parts. Individual parts and components are not available for distributor or field repairs. All CD players that require repair must be sent to Rowe for service.

Removing Mechanism Control Unit

If you have followed the troubleshooting procedure in *Section 5*, and you have found the mechanism control unit needs to be removed for factory service, follow this procedure:

1. Turn the POWER switch (on the back of the phonograph) OFF, or place the POWER switch (on the left side of the phonograph) in the OFF position.
2. Remove all connectors from the mechanism control unit (including the two attached to the player), loosen the mechanism control unit mounting screw (*figure 6-1*), and remove the mechanism control unit.

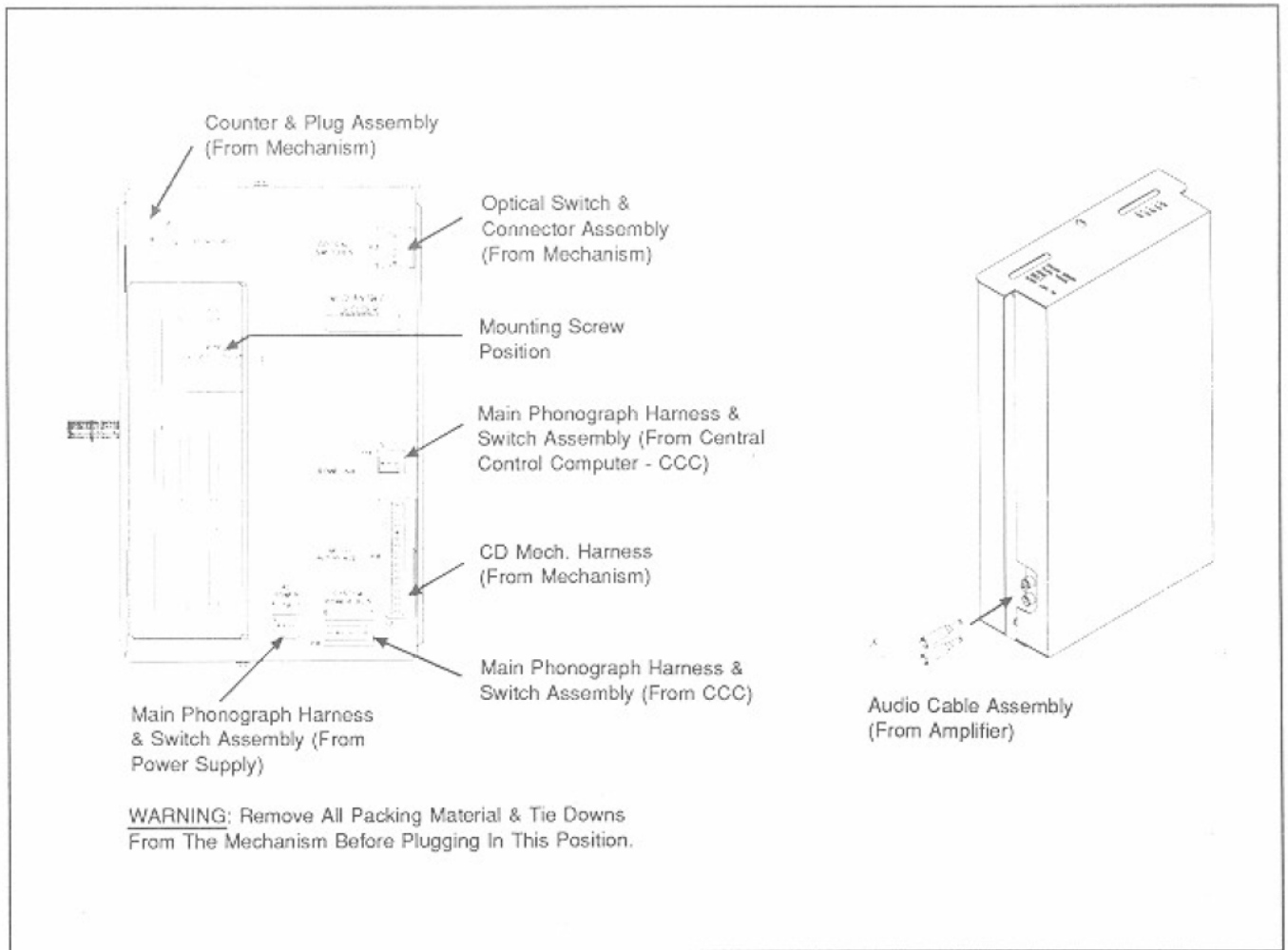

Figure 6-1. Mechanism Control Connecting Diagram

Removing The CD Player

1. Read the following Caution before you remove the CD player:



CAUTION:

The CD mechanism is extremely sensitive to static discharges. The photo diodes and the laser are more sensitive to discharges than MOS IC's. Careless handling may immediately destroy components within the player or cause undetectable damage that will lead to failure after several weeks or even months of use. Before you touch the player, discharge your hands and tools by touching a grounded metal part of the phonograph, such as the amplifier or power supply chassis. If you need to remove the CD player for servicing, place the CD player into the anti-static bag (shipped with the phonograph for this purpose) immediately after you remove it from the phonograph.

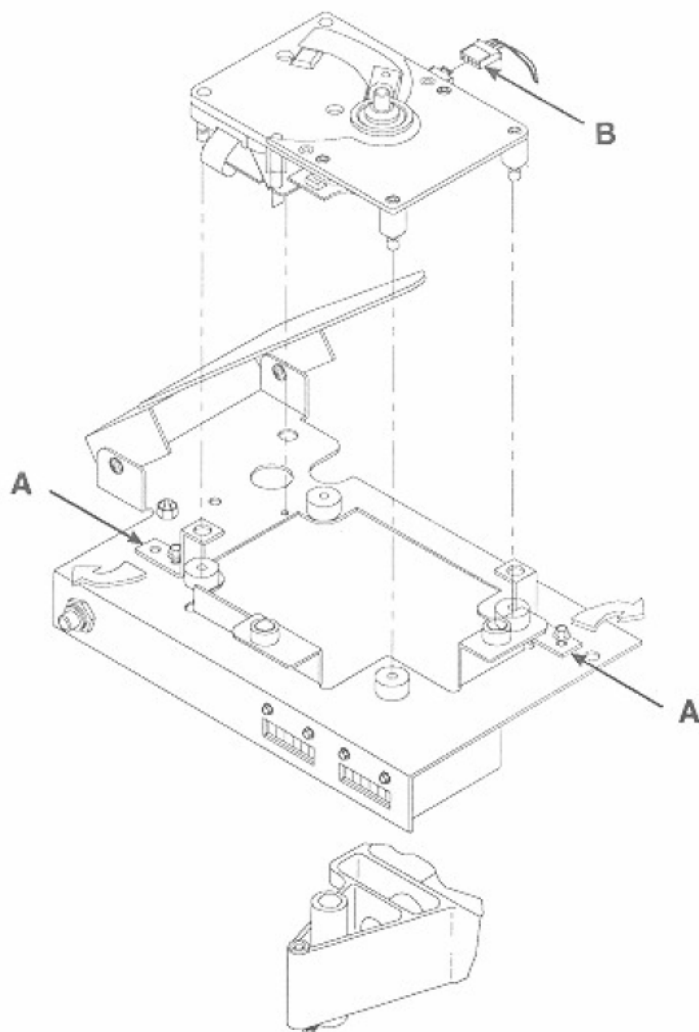

Figure 6-2A. Removing The CD Player

2. Refer to *figure 6-2A* as you do this step. To remove the player, loosen the screws holding the two retaining brackets (A) in place, swing the brackets out of the way, and lift the player straight up (If any of the four grommets from the player posts remain attached to the player, remove them from the player posts and place them in corresponding hole in the mounting frame).
3. Refer to *figure 6-2A* as you do this step. If not previously done, disconnect the small player electrical plug (B).
4. Refer to *figure 6-2B*. Remove the main CD harness, which is on the bottom of the CD player as follows:
 - A. Pull the locking tab away from the plug body and hold it away from the plug body.
 - B. Pull the plug out of the socket while you continue to hold the tab away from the plug body.
5. Immediately place the CD player into the anti-static bag (supplied with the phonograph) and return the CD player to your distributor.
6. To replace the CD player, reverse the previous steps. Make sure that the four grommets are in place in the holes in the mounting plate before pushing the player posts into the grommets. When you have properly positioned the CD player, make sure that all grommets are seated and that the CD player sets level in the mechanism frame.

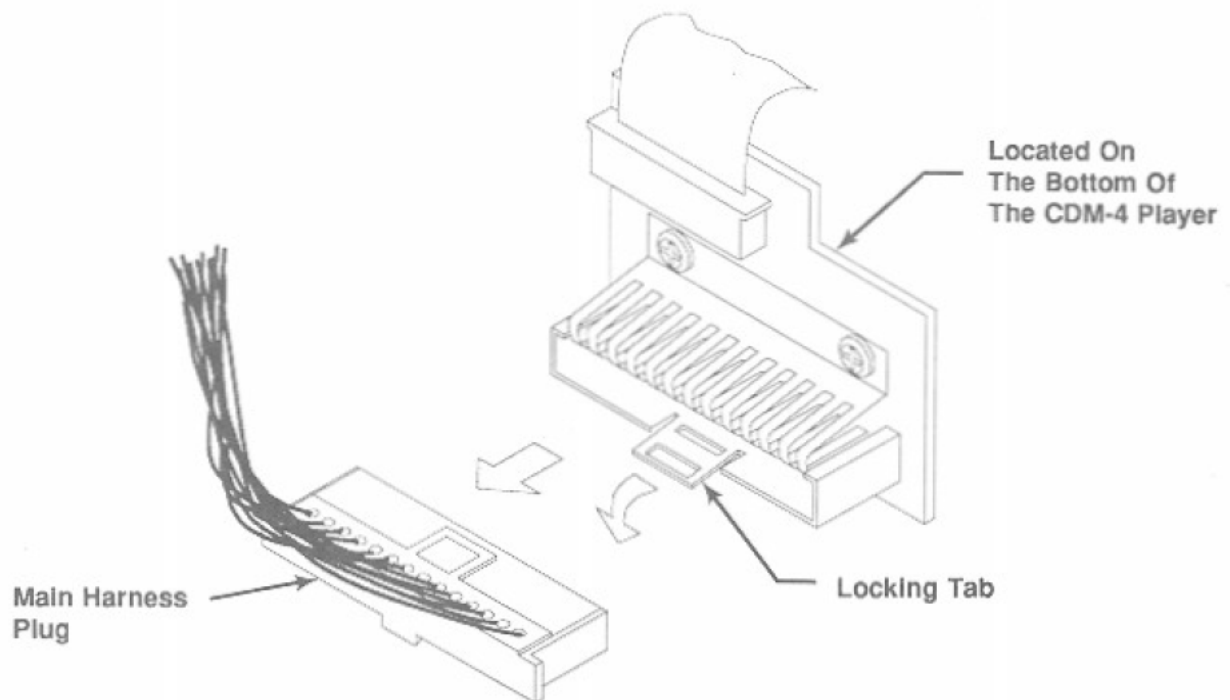

Figure 6-2B. Disconnecting The Main CD Player Harness

Hold Down Assembly And Hold Down Plate Height

SERVICE CHECK

With the gripper bow in the play position and the disc on the turntable (the outer cam switch is actuated), the aluminum hold down plate (figure 6-3) should be $3/32$ to $5/32$ inch ($1/8 \pm 1/32$) under the flange of the magnetic hold down hub.

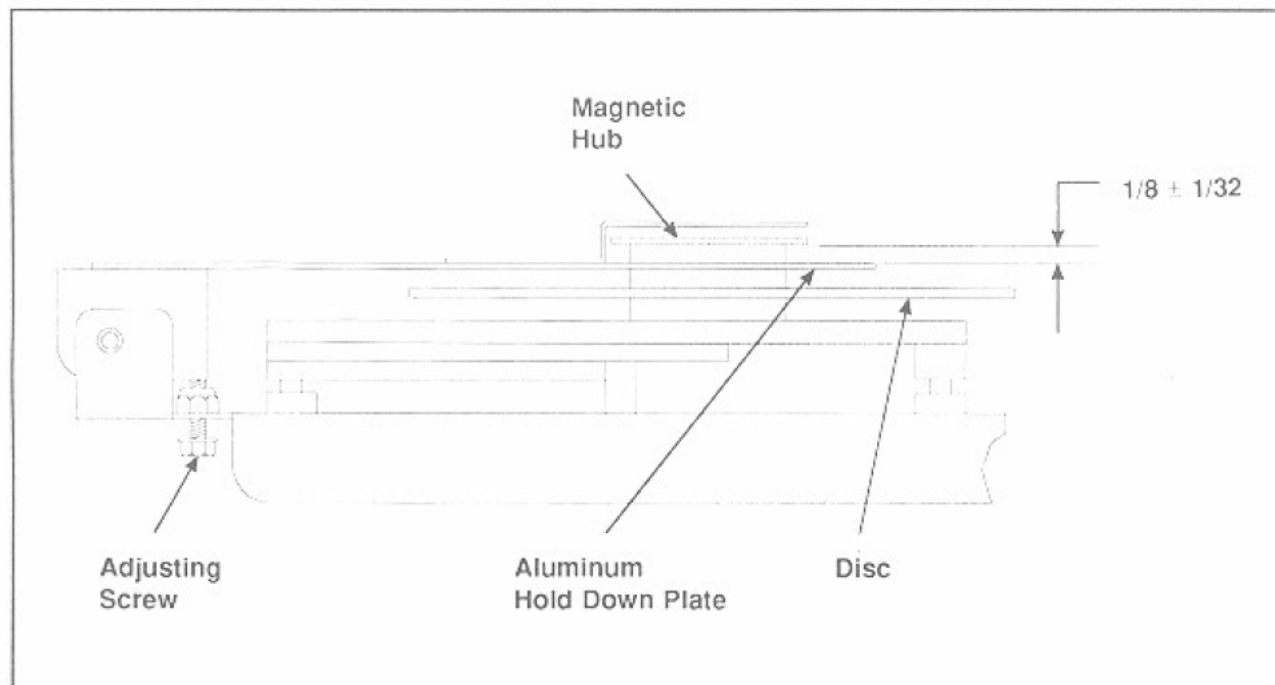

Figure 6-3. Hold Down Plate

ADJUSTMENT

If the hold down plate height is not correct, turn the adjustment screw (figure 6-3) until the $3/32$ to $5/32$ inch ($1/8 \pm 1/32$) height is attained.

HOLD DOWN PLATE CENTERING

Refer to figure 6-4 for this adjustment.

1. With the gripper bow in the PLAY position and the disc on the turntable, loosen the two centering adjustment screws slightly.
2. Look straight down on the turntable hub and rotate the hold down plate until the two "witness" marks are centered around the magnetic hold down hub.
3. Tighten the two centering adjustment screws and recheck the previous adjustments.

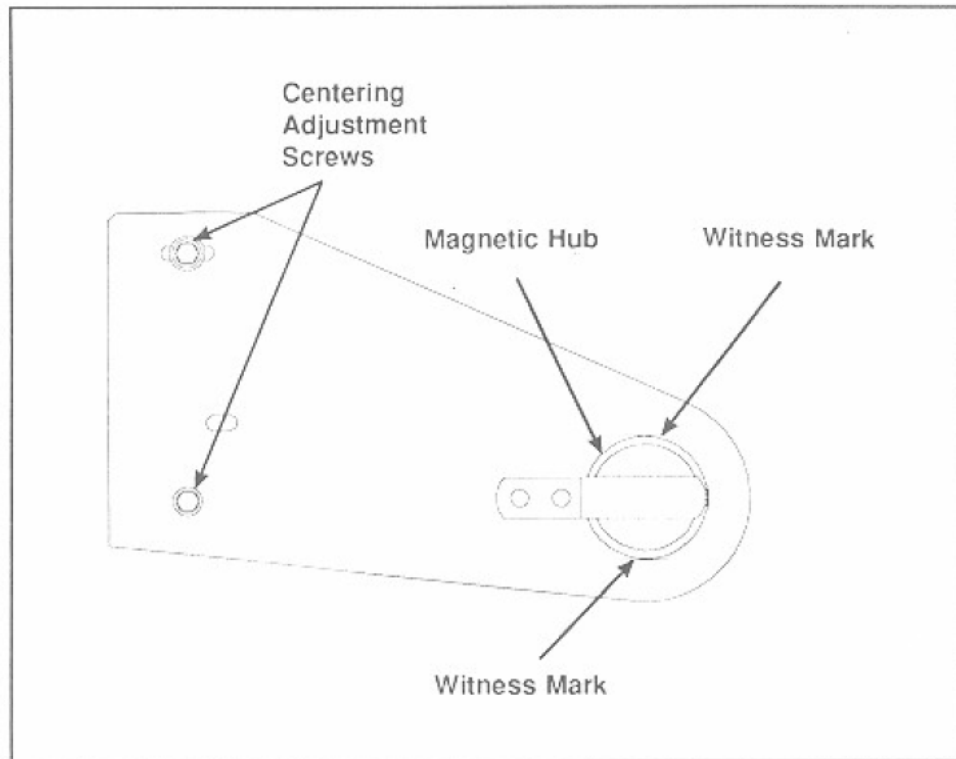

Figure 6-4. Hold Down Plate Centering

Optical Switch Adjustment

1. Push in the detent plunger, so that the magazine can be rotated to Position 99. Engage the detent plunger.
2. Loosen the optical switch bracket mounting screw, turn the adjustment knob counter clockwise to top of its travel, and move the bracket down to the bottom of its travel (refer to figure 6-5). Snug the optical switch mounting screw, so that the bracket can move with resistance.
3. With the detent plunger engaged, rotate the magazine counter-clockwise to remove gear backlash and maintain pressure for Steps 4 and 5.
4. Turn the adjustment knob clockwise until both the INDEX and HOME LED's are ON.

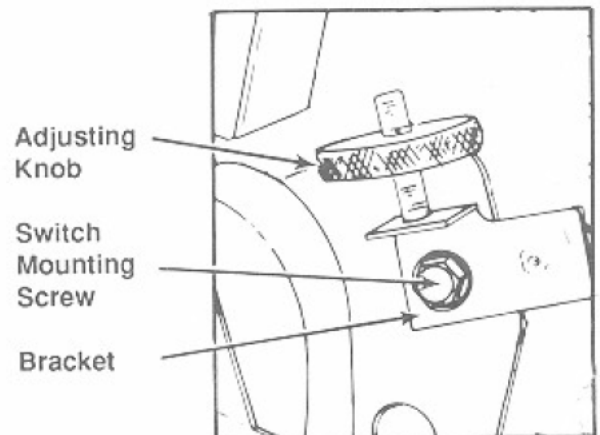

Figure 6-5. Optical Switch Adjustment

5. Continue turning the adjustment knob clockwise until the INDEX LED goes OFF. The HOME LED must remain ON. Then turn the knob one full turn clockwise and tighten the mounting screw. The INDEX LED must be OFF and the HOME LED can be ON or OFF.
6. Push in the detent plunger and rotate the magazine to Position 06.
7. With the detent plunger engaged, rotate the magazine in both directions as far as you can by hand (taking up the gear backlash in both directions). The INDEX and HOME LED's will remain OFF when properly adjusted.
8. Push in the detent plunger and rotate the magazine to Positions 56, 07, and 57. Repeat Step 7 at each position.

Sprag Assembly

ADJUSTMENTS

The following steps must be used to make sprag assembly adjustments.



WARNING:

Turn the power OFF before servicing the sprag assembly.

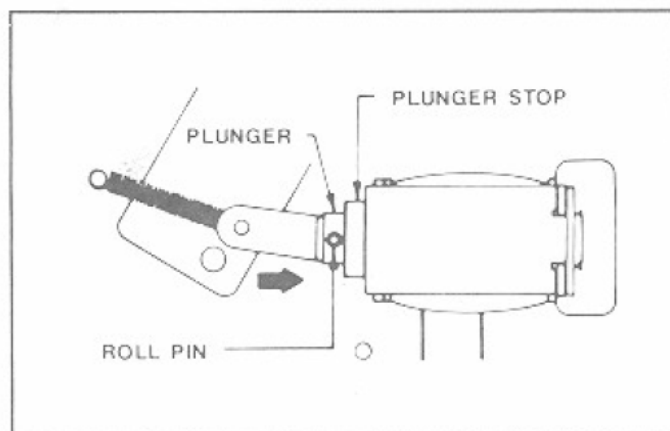

Figure 6-6. Sprag Assembly (Plunger)

1. Refer to figure 6-6. Depress solenoid plunger until the roll pin bottoms on the plunger stop (actuate by pressing on plunger).
2. Rotate the disc magazine and note the clearance between the sprag lever and the sprag wheel located on the backside of the sprag plate assembly.

The sprag lever must not touch the sprag wheel and the clearance must be .015 to .025 inches (see figure 6-7). It will be necessary to remove the sprag assembly if corrections are required.

SPRAG ASSEMBLY REMOVAL

1. To remove sprag assembly, disconnect wires to the solenoid and motor, remove the three mounting screws and slide the assembly out of the right side of the mechanism (see figure 6-8).
2. Loosen the solenoid mounting screws (see figure 6-9) and with the roll pin against the plunger stop, position the solenoid so that there is a .015 to .025-inch gap between the sprag lever and the highest point on the sprag wheel (see figure 6-7).
3. Tighten solenoid mounting screws.
4. Replace sprag assembly in mechanism with three mounting screws and replace the Black and White/Blue wires to the solenoid and the Yellow and Yellow/Black wires to the magazine motor.
5. After you have replaced the sprag assembly, perform the *Aligning Magazine Stopping Position With The Gripper Bow* procedure in this section.
6. To adjust the optical switch, refer to *Optical Switch* in this section.

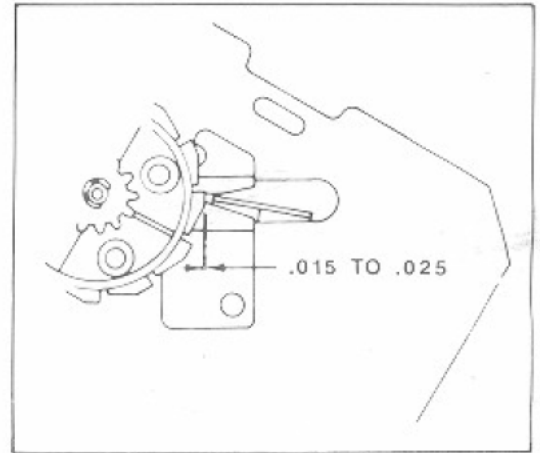

Figure 6-7. Sprag Wheel

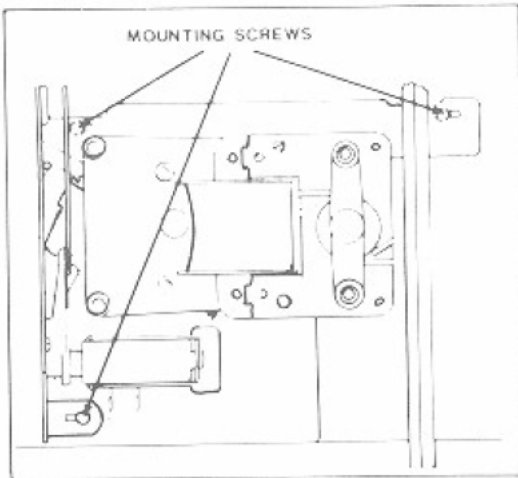

Figure 6-8. Sprag Assembly Removal

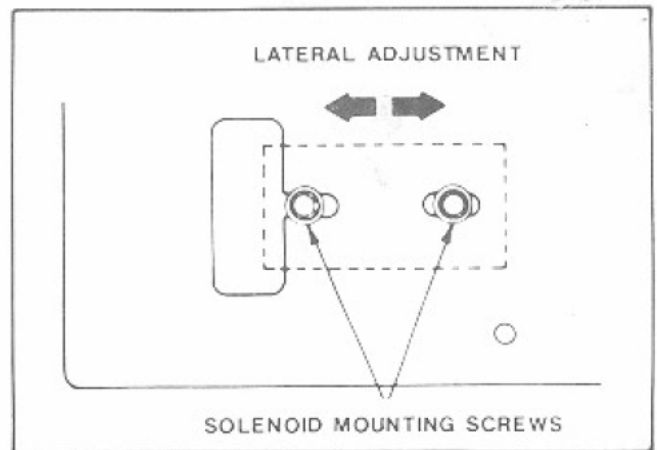

Figure 6-9. Lateral Adjustment

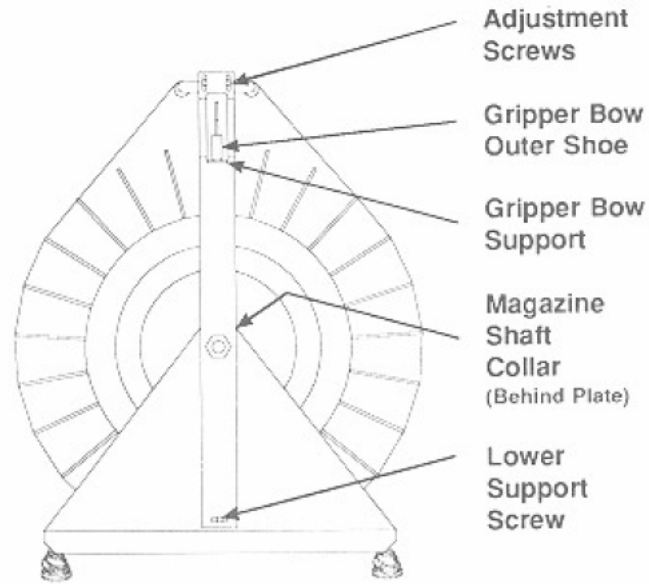

Figure 6-10. Magazine Belt Adjustment

Disc Magazine And Gripper Bow Support

See *figure 6-10* for this adjustment.

ADJUSTMENT

To eliminate magazine end play and to adjust the gripper bow support:

1. Loosen the set screws in rear magazine shaft collar. Push the collar on to magazine shaft to eliminate end play and tighten the screws.
2. Loosen the lower screw that holds the gripper bow support to the mechanism frame.
3. Adjust the gripper bow support so that the gripper bow outer shoe is centered in the opening.
4. Tighten the support to the frame with the lower screw.

Magazine Belt Adjustment

1. Loosen the two adjustment screws shown in *figure 6-10*.
2. Raise the bracket to tighten the belt around the magazine.
3. Check that belt rides evenly in the center of the belt guides, all the way around the magazine.
4. Tighten the two adjustment screws.

Cam Switch

ADJUSTMENTS

If you need to remove the switch cam from the transfer motor, the following procedure must be followed to ensure that the cam is properly located and not 180 degrees out of position.

Locate the inner lobe so that it is pointing in the same direction as the crank. Turn cam so that neither cam lobe is on a switch before removing or installing the cam (see *figure 6-11*).

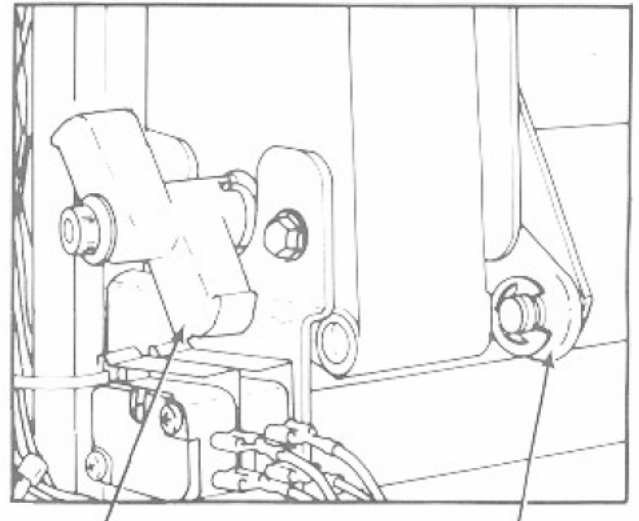

Inner Lobe

Crank

CAM SWITCH CHECK AND ADJUSTMENT

Figure 6-11. Cam Switch

1. Check that the leaf spring is resting in the cam lobes and that the switch plunger just touches the bottom of the leaf spring as shown in *figure 6-12*.
2. To adjust the switches, loosen mounting screw under plunger end and move the switch housing as described in the previous step (see *figure 6-12*).
3. Tighten mounting screw and recheck operation.

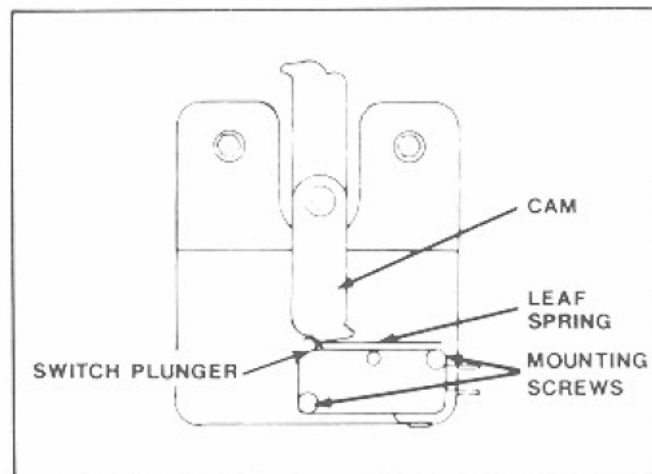

Figure 6-12. Cam Switch Adjustment

Aligning Magazine Stopping Position

With The Gripper Bow

1. Place a disc in any position in the disc magazine and rotate the magazine until this disc is in the top position. Allow the magazine sprag lever to engage and lock the magazine in this position.
2. Using a 5/32-inch Allen wrench in the end of transfer motor shaft, turn motor shaft clockwise until the gripper bow starts to lift the disc out of the magazine (see figure 6-13).
3. With the disc and gripper bow in this position, rock the magazine to the left and right to make sure the magazine vertical slot is centered relative to the edge of the disc.

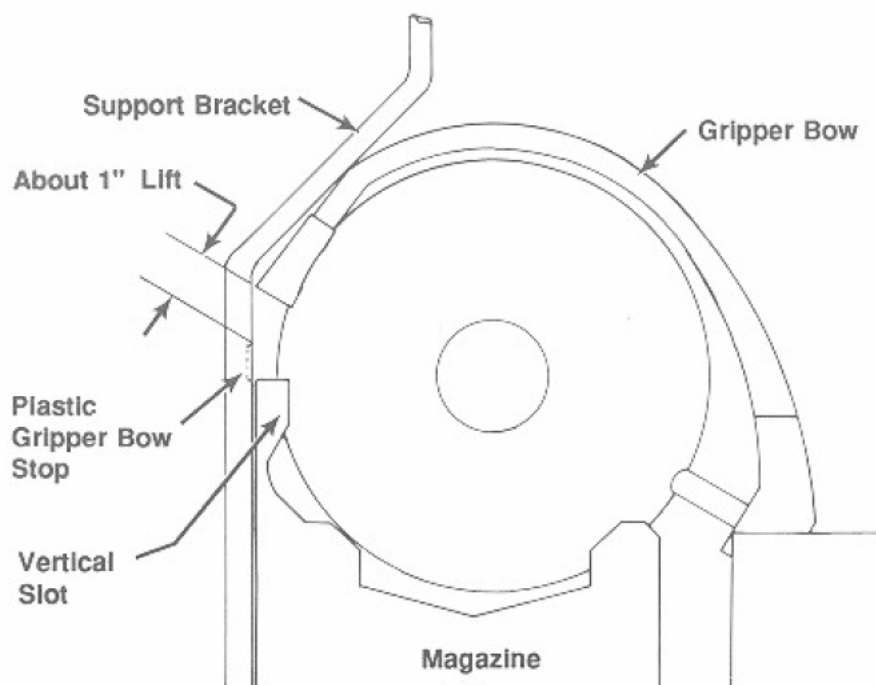

Figure 6-13. Magazine and Gripper Bow Stopping Position

IF ADJUSTMENT IS NECESSARY:

4. Loosen three screws in the magazine motor mounting plate.
5. With sprag wheel locked, move the magazine until the disc is centered in the magazine vertical slot (The adjustment screws will be approximately centered in the slots, *see figure 6-14*).
6. Tighten the three screws in the magazine motor mounting plate securely.
7. Perform the *Optical Switch Adjustment* described earlier in this section.

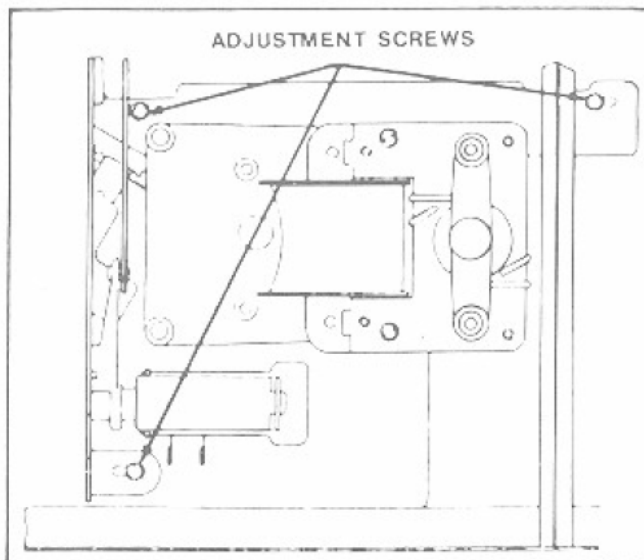

Figure 6-14. Magazine Adjustment

Title Rack Switch Adjustment



WARNING:

Do not attempt to turn the CD title pages by hand unless you use the handwheel on the back of the title rack (see figure 6-2A).

Refer to figure 6-15 for illustration of the title rack adjustment.

1. Open the top door, unplug the title rack from the phonograph, and remove the title rack from the phonograph.
2. Loosen the switch mounting screw and the adjusting screw so that the switch can be rotated.
3. Use the handwheel to move the rack and pinion (and the title rack pages) so that the switch roller is directly over the top of one of the rack lobes. This will cause two of the title rack pages to point approximately straight out.
4. Insert a 0.040-inch feeler gauge between the switch body and the switch actuator arm.
5. Slowly rotate the switch downward until all clearance between the switch and the switch body is removed.
6. Tighten the switch mounting screw and the switch adjustment screw.
7. Turn the handwheel in both directions and verify that the switch clicks before the roller reaches the bottom of the rack (as it rolls "down hill") and before it reaches the top of the rack (as it rolls "up hill"). This distance should be approximately halfway between the peaks and the valleys of the lobes.
9. Re-install the title rack.
10. Perform *Title Page Re-Synchronizing* that follows this step.

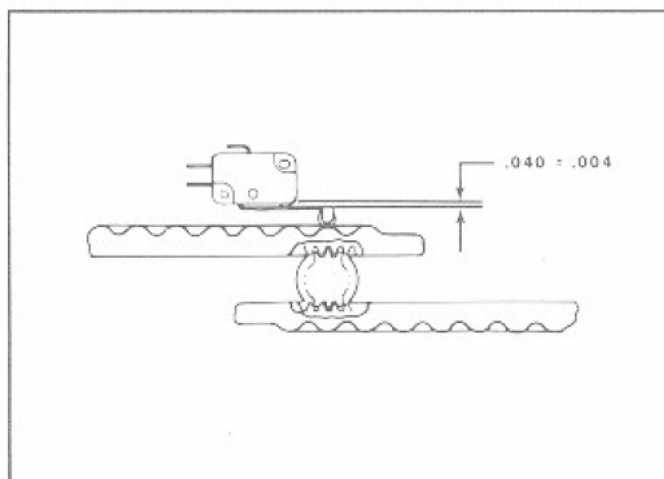

Figure 6-15. Title Rack Switch Adjustment

Title Page Re-Synchronizing

Title page re-synchronizing is necessary whenever power to the phonograph is interrupted or after the title pages have been changed with the handwheel.

1. Press either PAGE CHANGE button repeatedly until the pages no longer change (The pages may not advance as far as you expect them to. This is normal when the pages are being re-synchronizing).
2. Press the other PAGE CHANGE button repeatedly until the pages no longer change.

Section 7: Miscellaneous

CD-100C SPECIFICATIONS

General

Depth	26-1/2 in. (67.3 cm.)
Width	41-1/2 in. (105.4 cm.)
Height	61.6 in. (156.5 cm.)
Weight	415 lbs (188.6 Kg.)

Power Requirements	120 VAC 60 Hz., 530 watts 5.3 amps. 220 VAC 50 Hz., 560 watts 3.3 amps. 240 VAC 50 Hz., 560 watts 3.0 amps.
---------------------------------	--

CD Player And Changer

Capacity	100 Digital discs
Disc Size	5-inch or 3-inch

Credit And Pricing System

Accumulator Type Credit System	\$1 & \$5 bills \$1 & half-dollar coins are optional
--------------------------------	--

Coins Accepted	Nickels Dimes Quarters
----------------------	------------------------------

TOTAL CREDIT ACCUMULATIONS	65535
---	-------

PRICING	See Pricing, Section 2
----------------------	------------------------

Sound System

CD PLAYER

Type Philips Industrial CDM-4
 Frequency Response 20 to 20,000 Hz.
 Channel Separation 90 db @ 1,000 Hz.
 Output 1 V (approx. depending on the disc)

POWER AMPLIFIER

250 Watt Stereo

FTC Rating, 3 Ohm Loads @ .5% THD 250 watts RMS
 FTC Rating, 70 V Lines @ .5% THD 126 watts RMS

PREAMPLIFIER

AVC Control Range 40 db

Tone control is accomplished through a 7 band equalizer (10 db/filter band)

SELECTION SYSTEM CAPACITY 100 discs with a 99 max. selections per disc

TRANSFORMER PACKAGE

Power Levels For Phonograph Speakers 1, 4, 16, 64 watts
 (Provides 70-volt line for extension speakers)

SPEAKER SYSTEM

Characteristics	Woofers	Midrange	High Frequency
Speaker Diameter	12 in.	6 in.	3 in.
Voice Coil Diameter	1-½ in.	1 in.	Not Applicable
Impedance	8 ohms	8 ohms	8 ohms

SYSTEM FREQUENCY RESPONSE 20 to 20,000 ±4 db

Door Lighting Fluorescent – 30 watt, 36 in.
 14 volt incandescent

FUSES AND CIRCUIT BREAKERS

Main Power Supply

120 VAC (Transformer Primary Only)	2 amp. circuit breaker
120 VAC	10 amp. circuit breaker
+28 VDC	5 amp. Slo-Blo fuse
+8 VDC	5 amp. Slo-Blo fuse

Amplifier

120 VAC	6 amp. circuit breaker
32 VDC	8 amp. fuse (4)

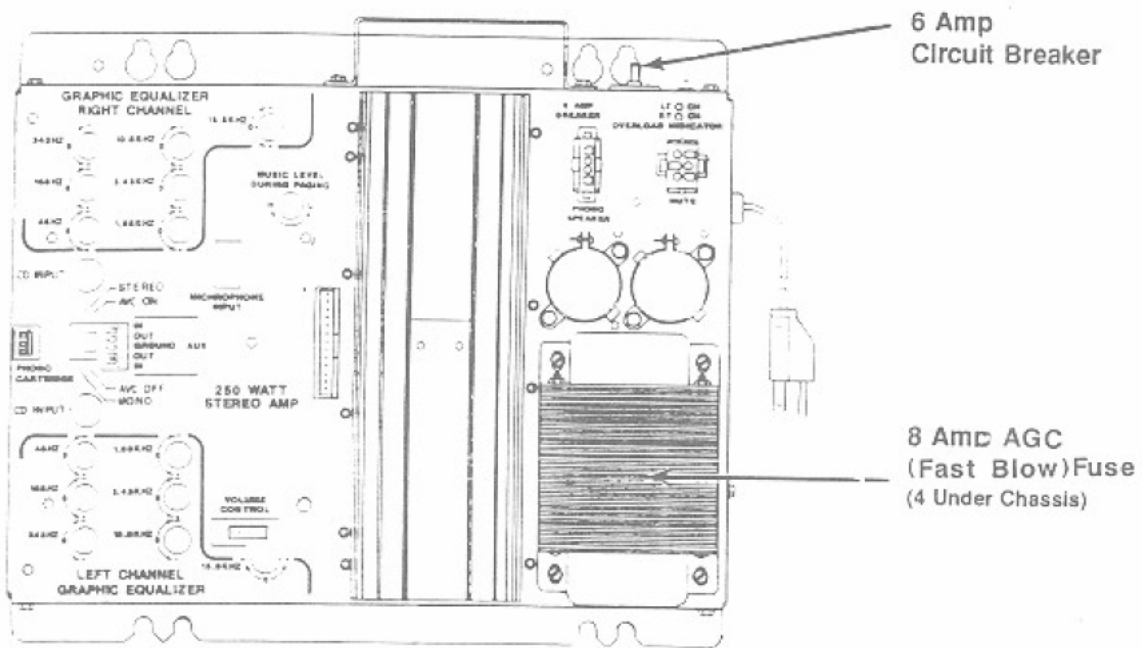

250 WATT AMPLIFIER

Two 5 Amp AGC Fuses
(Mounted on Power Supply Circuit Board)

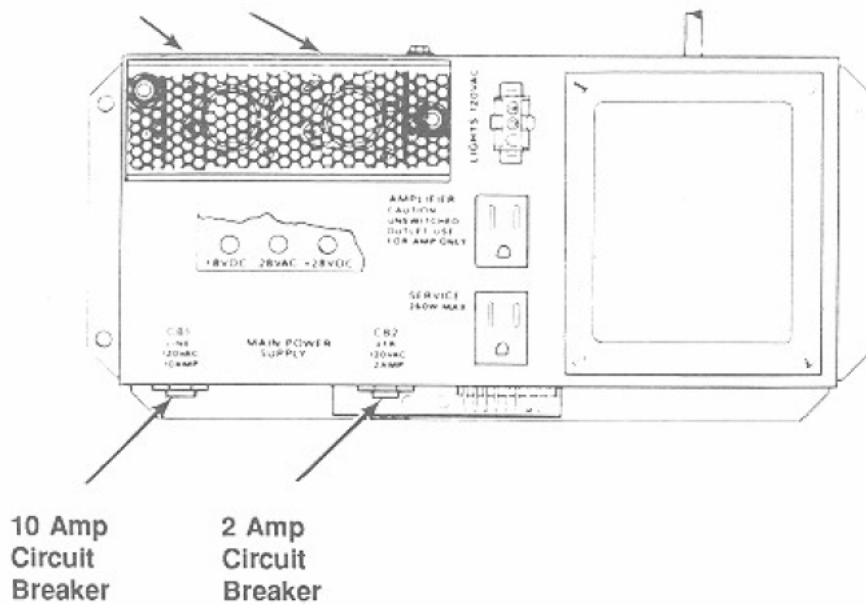

MAIN POWER SUPPLY

Figure 7-1. Fuse and Circuit Breaker Locations

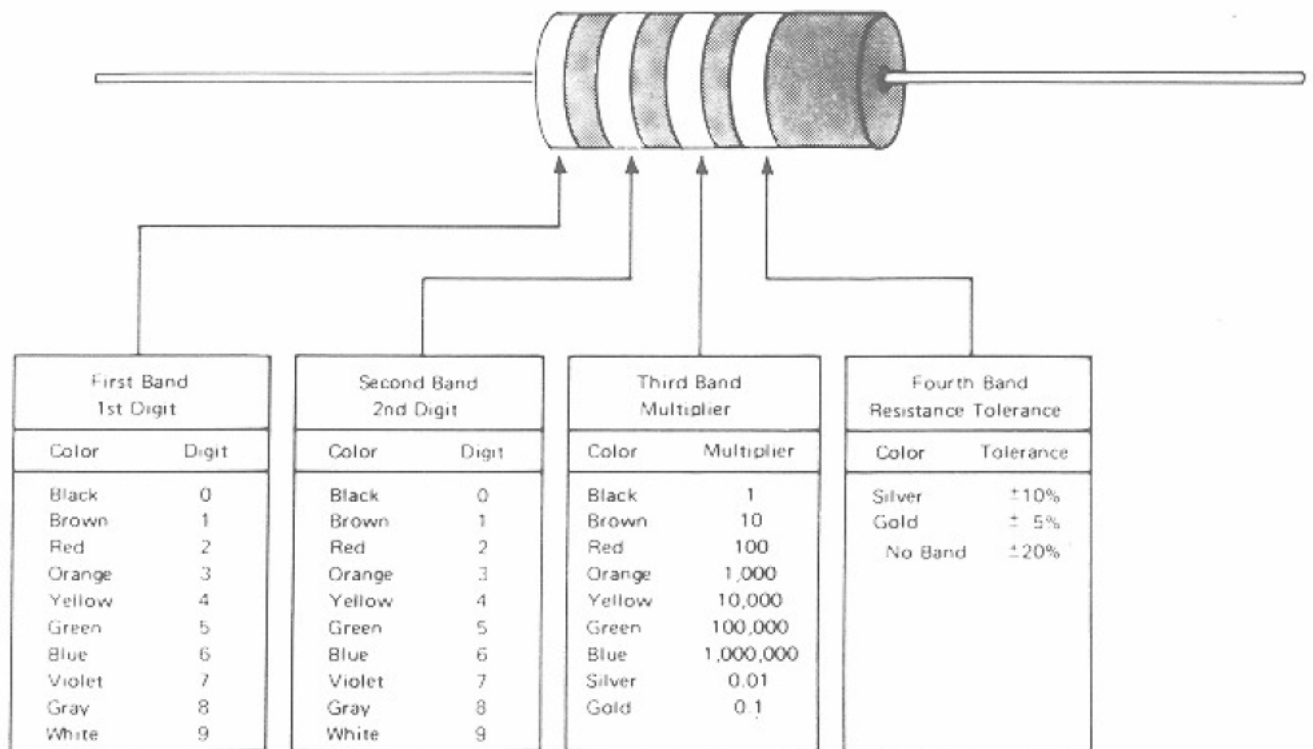

Figure 7-2. Resistor Color Code

Example: You have a resistor with the colors Yellow, Violet, Red, and Gold on it. Place the resistor in front of you so that the end of the resistor with no colored bands is on your right. Now, use the color code chart to decode the colors: the Yellow band=4, the Violet band=7, the Red band means multiply by 100. So the resistor value is 47X100, or 4700 ohms. The Gold band indicates that the resistor can be 5% over or 5% under the 4700 value and still be considered to be the proper value.

**NOTE:**

Testing a resistor while both ends of the resistor are connected to the circuit can give a false LOW reading. If the resistor value is critical, disconnect one end of the resistor from the circuit and use an accurate digital VOM.

This page intentionally left blank.

Section 8: Parts Catalog

<u>Paragraph</u>	<u>Page</u>
CD-100C CODE SHEET	8-2
INTRODUCTION	8-3
Catalog Description	8-3
Parts List Description	8-3
Ordering Replacement Parts	8-3
PHONOGRAPH ASSEMBLY EXTERNAL VIEW	8-4,7
TOP DOOR ASSEMBLY	8-8,10
HOUSING ANIMATION	8-12
FRONT DOOR ASSEMBLY	8-14
TITLE RACK ASSEMBLY	8-16
PHONOGRAPH ASSEMBLY INTERNAL VIEW	8-18
COIN CHUTE ASSEMBLY	8-20
CBA-2 BILL ACCEPTOR ASSEMBLY	8-22
CBA-2 TRANSPORT ASSEMBLY	8-24
Upper Track	8-26
Lower Track	8-27
Motor and Gear Assembly	8-28
Stacker Assembly	8-29
AMPLIFIER COMPARTMENT	8-30
Stereo Amplifier Assembly	8-32
Heat Sink Detail	8-34
Output Transformer Assembly	8-35
Main Power Supply	8-36
Central Control Computer Assembly	8-38
MECHANISM ASSEMBLY	8-40, 42, 44, 46
Sprag Assembly	8-48
Cam Switch and Motor Assembly	8-49
ACCESSORY EQUIPMENT	8-50

COUNTRY 1st & 2nd DIGIT	PACK 3rd DIGIT	CD-100C SUB-ASSEMBLY 4th & 5th & 6th DIGIT	AMPLIFIER 7th DIGIT	BILL ACCEPTOR 8th DIGIT
01 = US	1 = DomPack = 2-19664-01	300 = Silver (60 HZ) = 6-10600-01 301 = Silver (50 HZ) = 6-10600-02	0 = None 1 = 2 = 3-06322-09 Remote 3 = Volume Cont. Assy 4 = 5 = 250u Amp 6 = 6-10248-02 7 = 250u Amp 8 = 6-10248-02 9 = with 3-06322-09 Remote Volume Control	0 = None 1 = 2 = 3 = 4 = 5 = CBA-2 2-19671-01 6 = W/Stacker 7 =
02 = Arg				
03 = Australia				
04 = Aus				
05 = Bah				
06 = Belg				
07 = Canada				
08 = Chile				
09 = Col				
10 = Costa R				
11 = Neut. Stk				
12 = Denmark				
13 = Ecuador				
14 = El Salv				
15 = England				
16 = Finland				
17 = France				
18 = Germany				
19 = Guat				
20 = Holland				
21 = Hon				
22 = Italy				
23 = Belize				
24 = Japan				
25 = Mexico				
26 = Nrc				
27 = Norway				
28 = Aruba				
29 = Panama				
30 = Curaco				
31 = Spain				
32 = Sweden				
33 = Swiss Fr				
34 = Swiss Ge				
35 = Swiss It				
36 = Trinidad				
37 = Eng Video				
38 = Venez				
39 = Zambia				
40 = Puerto R				
41 = Guyana				
42 = Brazil				
43 = Barbados				
44 = Surinam				
45 = Yugo				
46 = S. Africa				
47 = US (220V)				
48 = US (240V)				
49 = Singapore				
50 = Israel				
51 = Korea				
52 = Greece				
53 =				

SAMPLE:

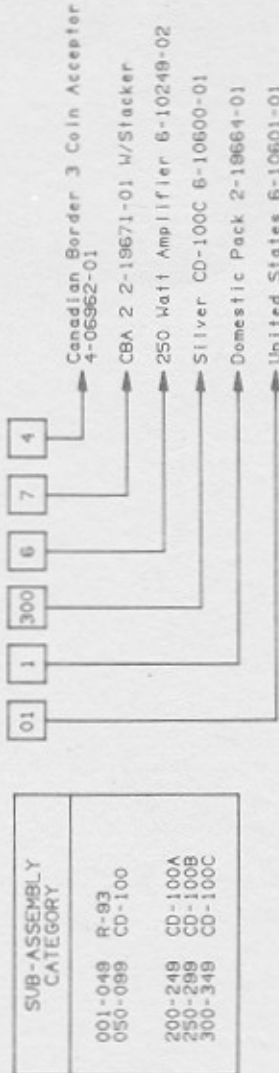

INTRODUCTION

This parts catalog lists procurable replacement parts for the phonograph. The purpose of this parts catalog is to locate and identify replaceable components and supply information on how to order them.

Catalog Description

This catalog is divided into major sections labeled figures, which correspond to the illustrations used. Some assemblies require more than one illustration to identify the parts. Each page has a sheet number to identify the sheet as part of that assembly's parts list.

Since replacing parts that are welded or riveted onto an assembly is normally impractical, replacement parts are not listed for these items. The assembly that contains the welded part should be replaced.

Parts List Description

The parts list contains four columns:

- **Figure, Sheet, and Index Number** — The first entry in this column is the figure number of the corresponding illustration. An index number, when listed, corresponds to the index number appearing on the illustration. Index numbers are not used when items are listed for reference purposes only or when the item listed is an alternate part.
- **Rowe Part Number** — This column lists the part number to use when ordering replacement parts or making inquiries.
- **Description** — This column gives a word description of each part or assembly. Each item is indented to show its relationship to the next higher assembly.
- **Qty** — This column contains the part quantity used in the assembly. When a figure describes more than one model of an assembly, the "Qty" column is divided to show each model.

Ordering Replacement Parts

All replacement parts must be ordered directly from an authorized Rowe Distributor.

Once the replacement item has been determined, complete a Standard Parts Order Form. (available from your Rowe Distributor at no charge) Very often parts orders are delayed because of inadequate or incompletely filled out parts order forms. To enable prompt delivery, always specify the following information:

- Part Number and Description (indicate color, if applicable)
- Quantity required
- Machine Model and Serial Number
- Complete shipping address, including the ZIP code
- Shipping Instructions must be supplied. If the shipping method is Parcel Post, Air Parcel Post, United Parcel Service, or Air UPS, and the packages may exceed the size and weight limits of these services, indicate an alternate shipping method.

If the shipment must be delivered as fast as possible, specify "Fastest Way". Rowe will select the carrier for orders that justify shipment by truck.

Figure 8-1. CD-100C Phonograph External View

Sheet 1

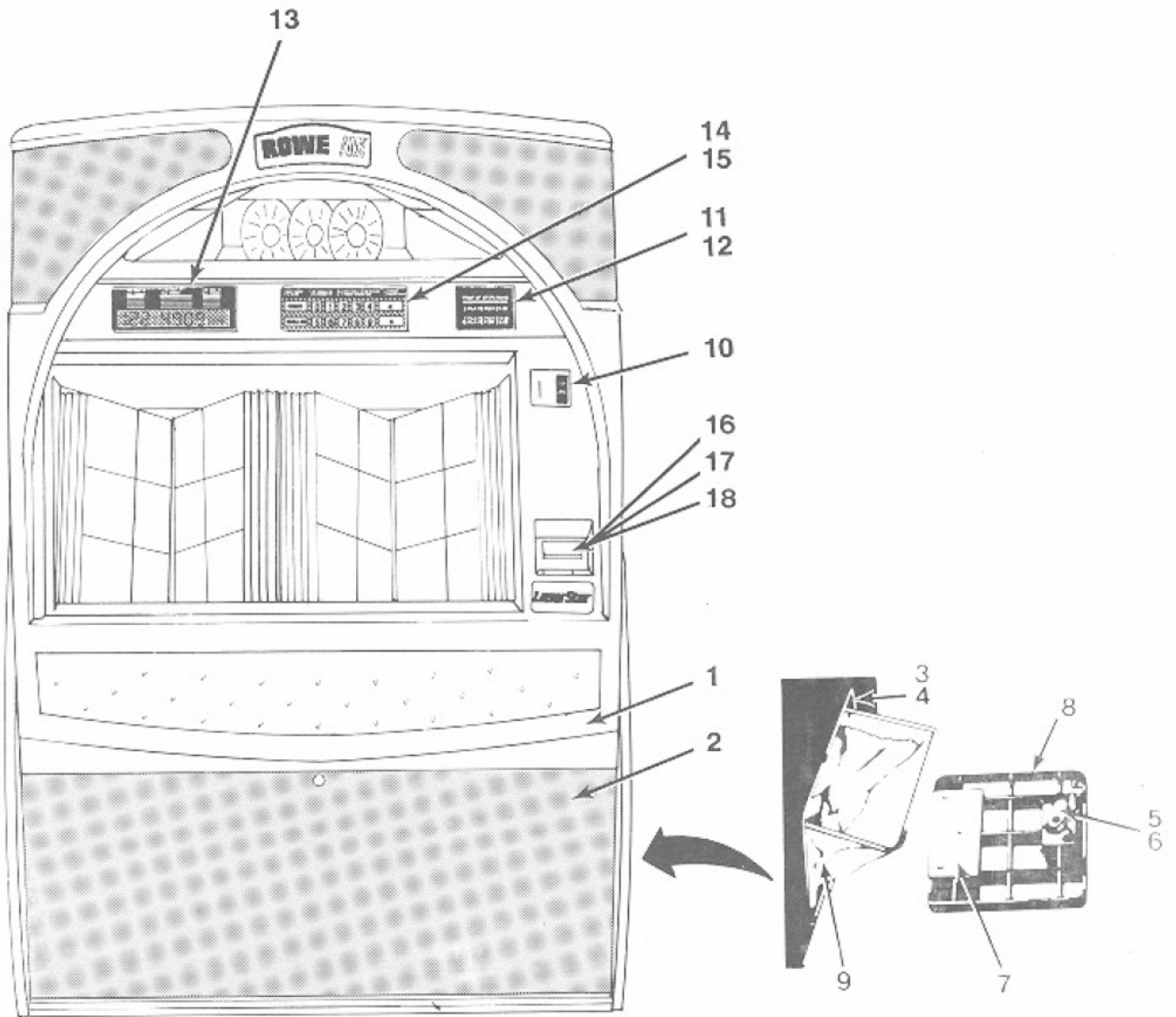

Figure 8-1 CD-100C Phonograph External View (Sheet 1)

Ref.	Part No.	Description	Qty
	61060001	CD-100C Phonograph Assembly	Ref.
1	61060501	Top Door Assembly (<i>see figure 8-2</i>)	1
2	61061001	Front Door Assembly (<i>see figure 8-4</i>)	1
3	40527605	• Frame - Cash Box Door	1
4	21776005	• "U" Type Speed Clip	1
	21186605	• Cash Box Door Assembly	1
5	70162004	• Cylinder - Lock (Individual Keying)	1
6	20669501	• Support - Lock	1
7	20770301	• Bracket - Catch	1
8	60326705	• Door - Cash Box	1
9	30702601	• Bag - Cash	1
	70212507	• Felt Strip (Adhesive Back)	1
	70166008	• Lock Bolt - Straight	1
10	30962201	• Blockout - Coin Inlet	1
11	21845612	• Window - Price Card	1
12	Ref.	• Price Card (<i>see the table on the following page</i>)	1
13	Ref.	• Card Readout (<i>see the table on the following page</i>)	1
14	21845616	• Window - Selector	1
15	Ref.	• Card-Selector Graphics (<i>see the table on the following page</i>)	1
16	40854401	• Blockout - Bill Acceptor	1
17	30966501	• Decal - Bill Acceptor Blockout	1
18	21968301	• Retainer - Bill Acceptor Blockout	1

Price Card Part Numbers			
Price Card Language	Price Card	Readout Card	Selector Graphics Card
Standard	30931304	30967001	30944702
Spanish	30952901	30967003	30953101
German	30952902	30967004	30953102
French	30952903	30967005	30953103
England	30952906		
England	30952916		

Figure 8-1. CD-100C Phonograph External View

Sheet 2

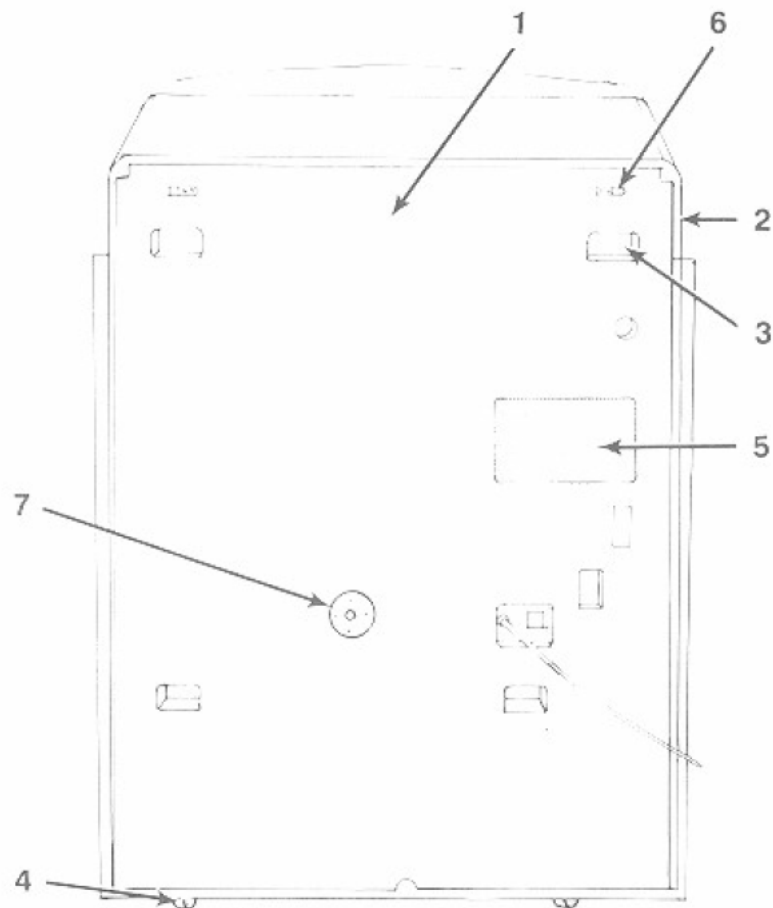
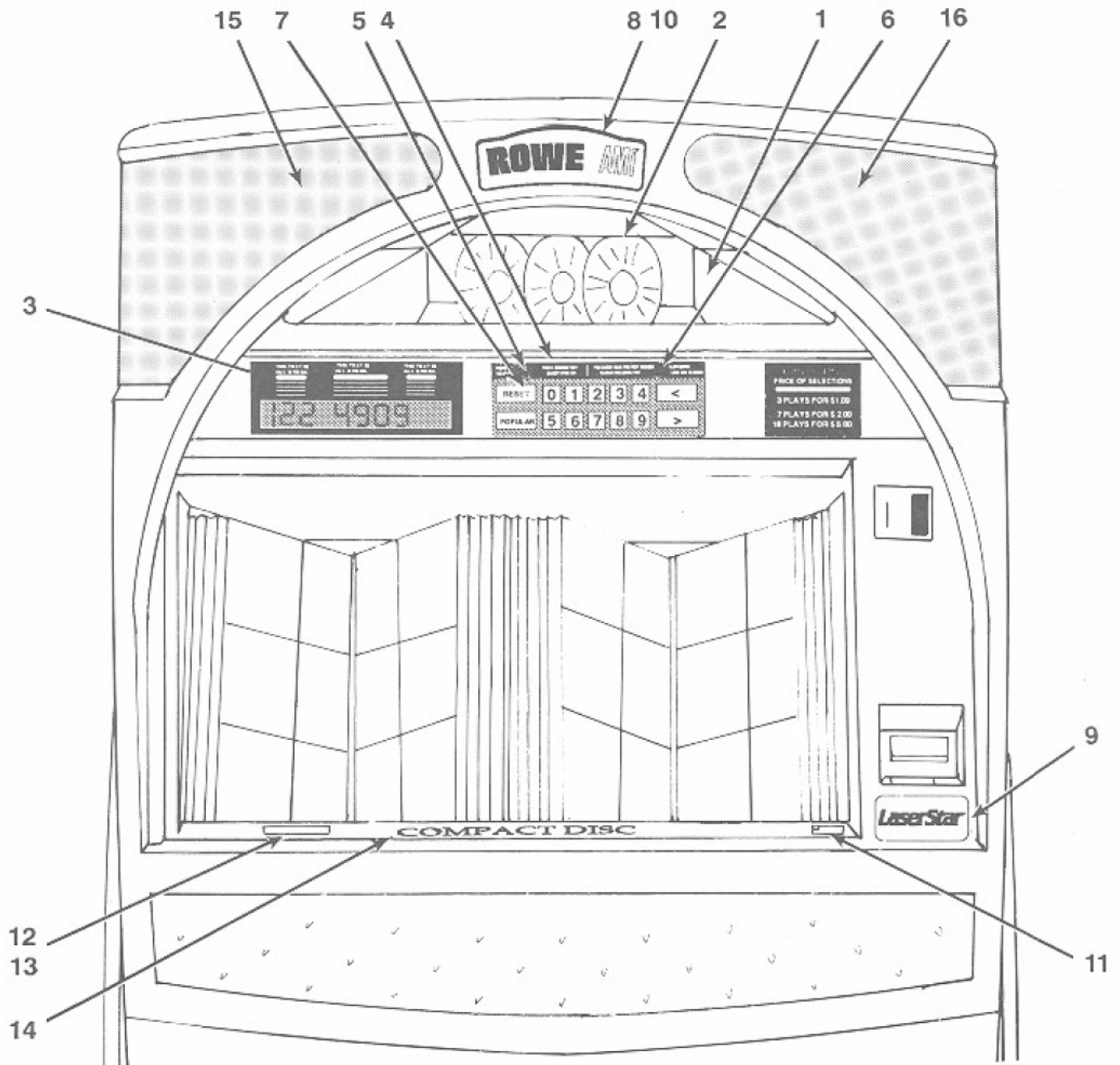

Figure 8-1 CD-100C Phonograph External View (Sheet 2)

Ref.	Part No.	Description	Qty
	61060001	CD-100C Phonograph Assembly	Ref.
1	61065001	• Shell - CD100-C	1
	60927901	• Bracket-Cash Bag	1
	21451801	• Spring - Lock	1
	30866907	• Strap - Protective	2
	70240126	• Screen - Wire Mesh	1
	20932601	• Tee Nut	4
	21750619	• Tube - Vent	1
	21750620	• Tube - Vent	1
2	40702810	• Rail - Skid	2
3	30625701	• Hand Hold Cover	4
4	30634001	• Caster and Cup Assembly	4
5	30868402	• Screen - Enclosure	1
6	20879501	• Bracket - Retainer	2
7	21265203	• Tie Down Plate Assembly	1

Figure 8-2. CD-100C Phonograph Top Door Assembly

Sheet 1



Ref.	Part No.	Description	Qty
	61060501	Door Assembly — Top	Ref.
1	40854201	• Window - Animation	1
2	61060601	• Animation Assembly	1
3	21845610	• Window - Digital Display	1
4	61040801	• Trim - Keyboard	1
5	30944702	• Card - Graphics (Keyboard)	1
6	21845616	• Window	1
7	40839403	• Keyboard Assembly	1
	21949601	• Keyboard Key Kit - Complete Set Of Numbers	1 Set
	21949701	• Keyboard Key Kit - Four Button Set (POPULAR, <<, >>, RESET)	1 Set
8	30963801	• Emblem - Rowe	1
9	21968601	• Decal - Laserstar	1
10	70135514	• Palnut (5/32)	2
11	25223101	• Label - Flag	1
12	30921502	• Frame - License	2
13	21921001	• Retainer - License	2
14	40855701	• Decal - Compact Disc	1
15	61062101	• Grille - Upper (R.H.)	Ref.
16	61062001	• Grille - Upper (L.H.)	Ref.

Figure 8-2. CD-100C Phonograph Top Door Assembly

Sheet 2

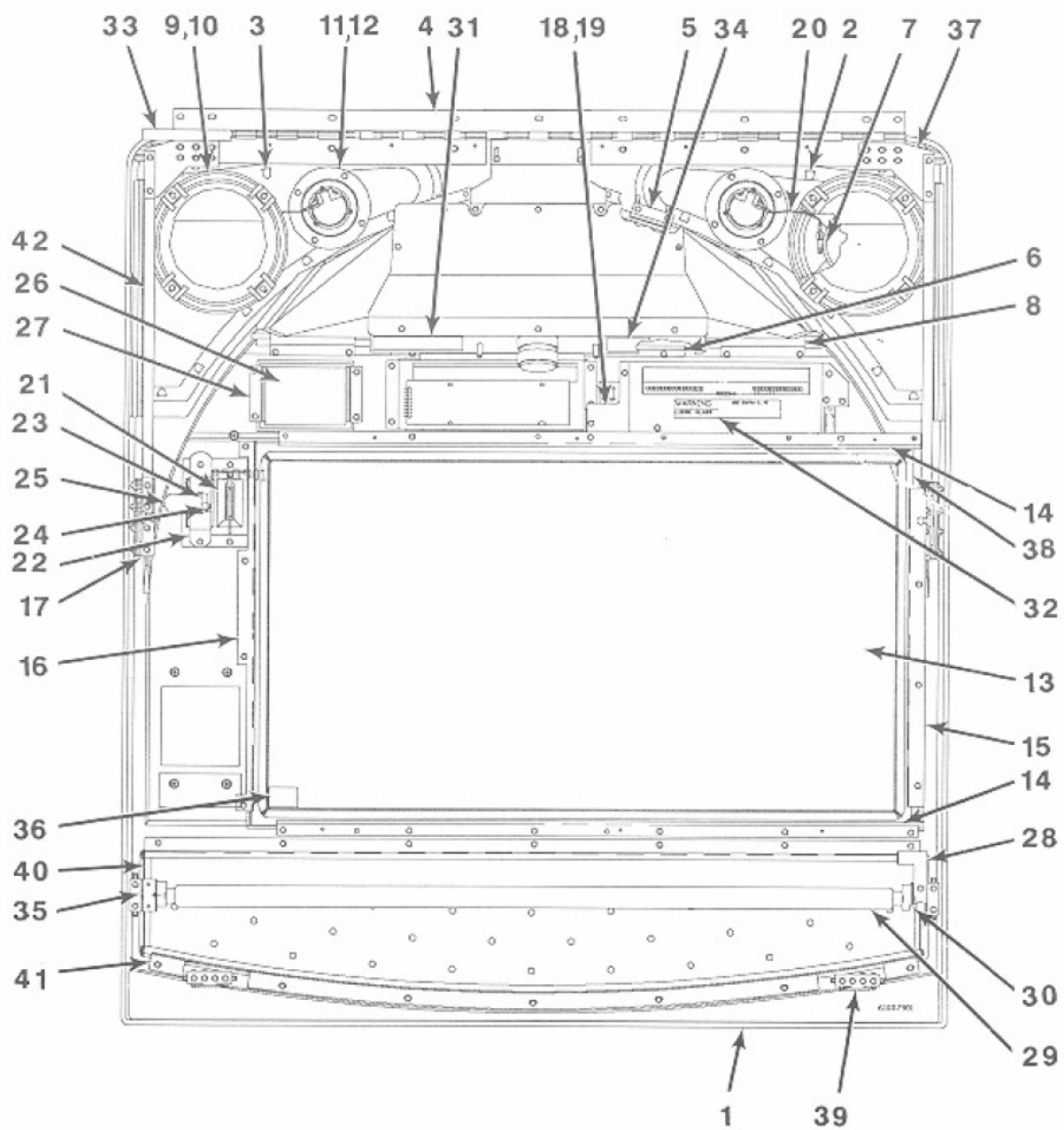

Ref.	Part No.	Description	Qty
	61060501	Door Assembly — Top	Ref.
1	61007901	• Frame - Door	1
2	61062001	• Grille - Upper (L.H.)	1
3	61062101	• Grille - Upper (R.H.)	1
4	61061901	• Hinge	1
5	21966501	• Retainer - Animation Window (Upper)	2
6	30964101	• Retainer - Animation Window (Lower)	1
7	40830803	• Speaker - Midrange (6")	2
8	30962401	• Bracket - Animation Mounting (Lower)	2
9	30951201	• Pad - Acoustical	4
10	61042801	• Housing - Speaker	2
11	40830902	• Speaker - Tweeter (3")	2
12	21944401	• Spacer - Speaker	8
13	21961102	• Window - Front	1
14	30963501	• Bracket - Window (Top & Bottom)	2
15	30966801	• Bracket - Window (LH)	1
16	30966901	• Bracket - Window (RH)	1
17	21966201	• Pivot Assembly - Gas Spring	2
18	40855001	• Digital Display Assembly	1
19	30967001	• Card - Digital Display	1
20	25240601	• Jumper Assembly	2
21	40853901	• Inlet - Coin	1
22	30964401	• Bracket - Guide	1
23	21834801	• Channel	2
24	21822901	• Spring - Compression	1
25	21742912	• Button & Shaft Assembly	1
26	21845612	• Window - Price Card	1
27	21966301	• Bracket - Price Card	2
28	21968801	• Actuator - Service Switch	1
29	70060112	• Lamp - Flourescent (30 W T-8)	1
30	70080004	• Starter - Flourescent	1
31	30935302	• Label - Speaker Harness	1
32	21948801	• Label - Warning	1
33	70220453	• Foamed Tape	1
34	21956801	• Label - Lamp	1
35	30963301	• Bracket - Light	2
36	21922001	• Sticker - CD	1
37	30964001	• Bracket - Corner Brace	2
38	61061801	• Frame - Window	1
39	30963401	• Strike	2
40	61062601	• Scene Assembly	1
41	30963101	• Bracket - Mounting (Scene)	1
42	30967501	• Strap - Door Support	2

Figure 8 - 3 CD-100C Housing Animation

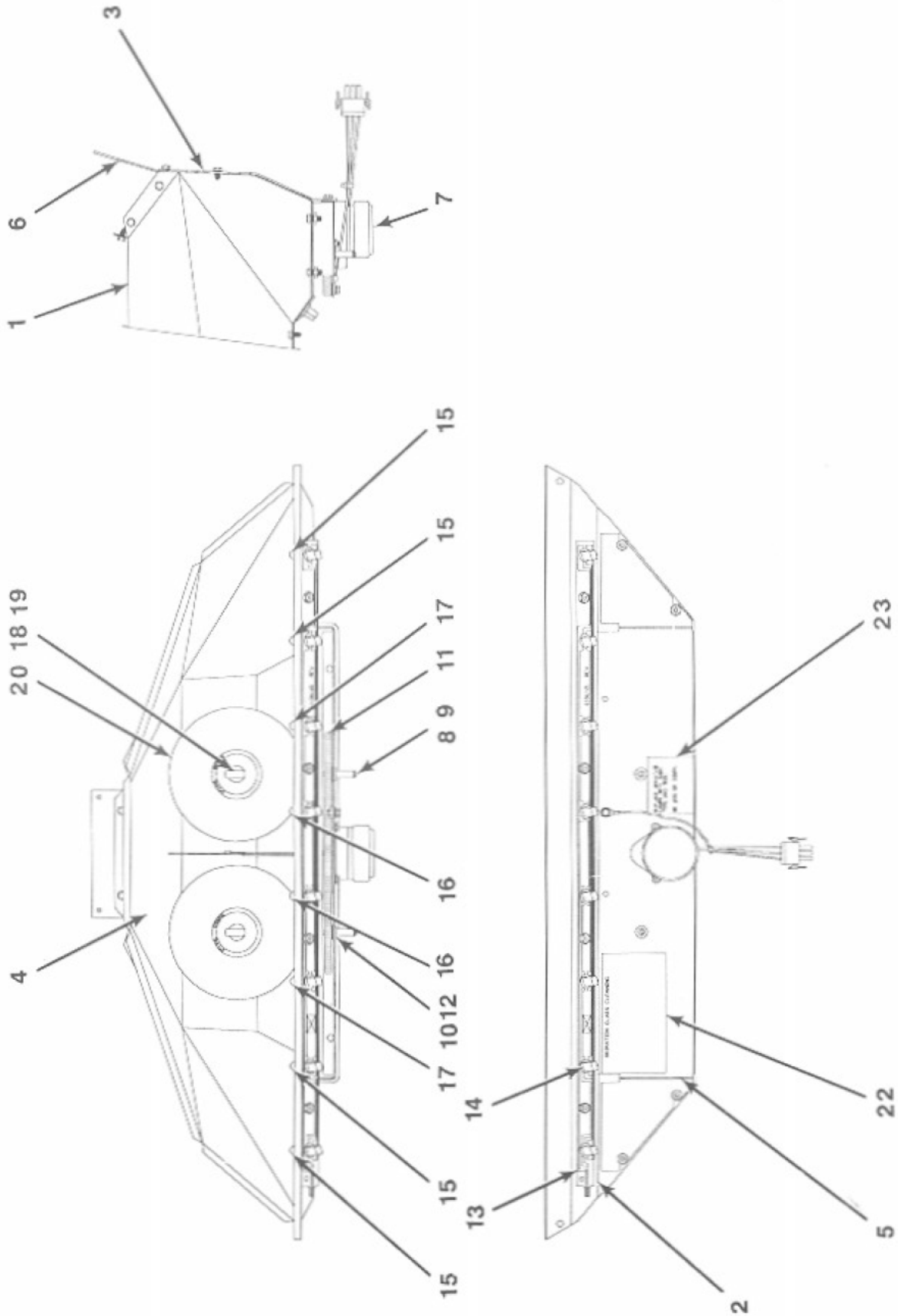

Ref.	Part No.	Description	Qty
	61060601	Animation Assembly	
1	61058501	• Housing-Animation (Top & Ends)	1
2	61058401	• Housing-Animation (Base)	1
3	61058201	• Housing-Animation (Rear)	1
4	61058301	• Housing-Animation (Top Rear)	1
5	30962601	• Plate Assy-Animation Drive	1
6	30962501	• Brkt-Animation Mtg (Upper)	1
7	40824302	• Motor & Harness Assy	1
8	30936702	• Shaft	2
9	70143001	• Ring-External Retaining	4
10	21110001	• Washer-Thrust	2
11	40834901	• Gear	3
12	21532801	• Speednut-Push On	3
13	61061101	• PWB-C.D. Animation	1
14	21862201	• Lamp & Socket Assy	8
15	30866501	• Lens-Brown	4
16	30866504	• Lens-Magenta	2
17	30866503	• Lens-Clear	2
18	40834801	• Support -Disc	3
19	21922201	• Ring-Compression	3
20	30926904	• Disc-Animation	3
21	21922602	• Label-Copyright (Not Shown)	1
22	21969401	• Label-Animation Glasss Cleaning	1
23	21956801	• Label-Lamp	1

Figure 8 - 4 CD 100C Front Door Assembly

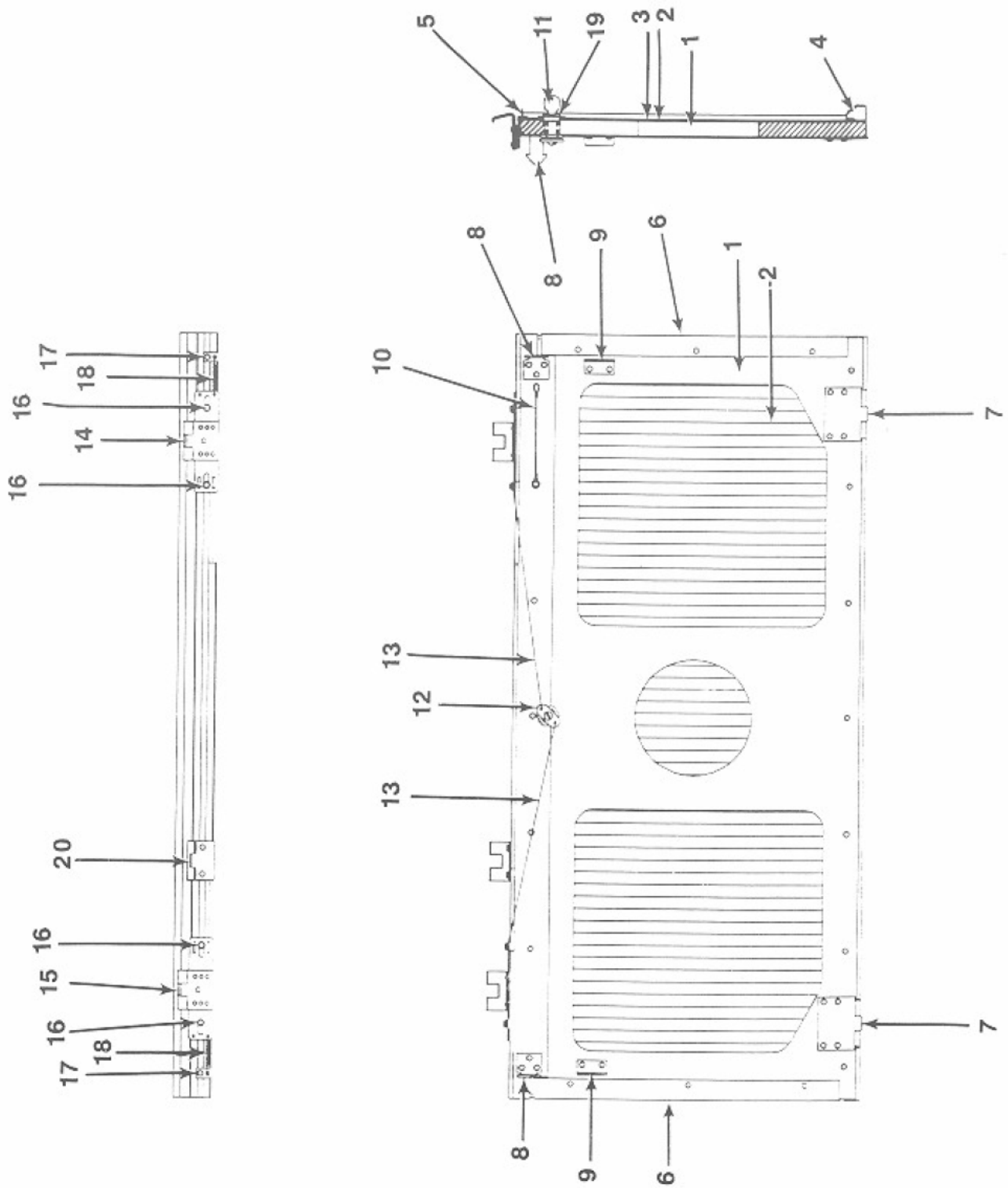

Ref.	Part No.	Description	Qty
	61061001	Front Door Assembly	Ref.
1	61068801	• Panel - Door (Lower)	1
2	40854601	• Scrim - Front Door	1
3	61060701	• Grille - Lower	1
4	61058601	• Trim - Bottom	1
5	61068701	• Lockbar	1
6	61057101	• Trim - Side	2
7	21940801	• Strap - Hinge	2
8	21965701	• Strike	2
9	21920101	• Bracket - Upstop	2
10	21572601	• Cable - Fall Stop	1
11	70163211	• Cylinder - Lock (Common Keying)	1
12	21425601	• Lockbolt	1
13	21865305	• Link - Pivot	2
14	21965901	• Lockbar Assy (LH)	1
15	21966001	• Lockbar Assy (RH)	1
16	20922502	• Spacer	4
17	21567401	• Retainer - Spring	2
18	21256201	• Spring - Tension	2
19	21795302	• Bezel - Lock	1
20	21969101	• Bracket - Alignment	1

Figure 8-5 Title Rack Assembly

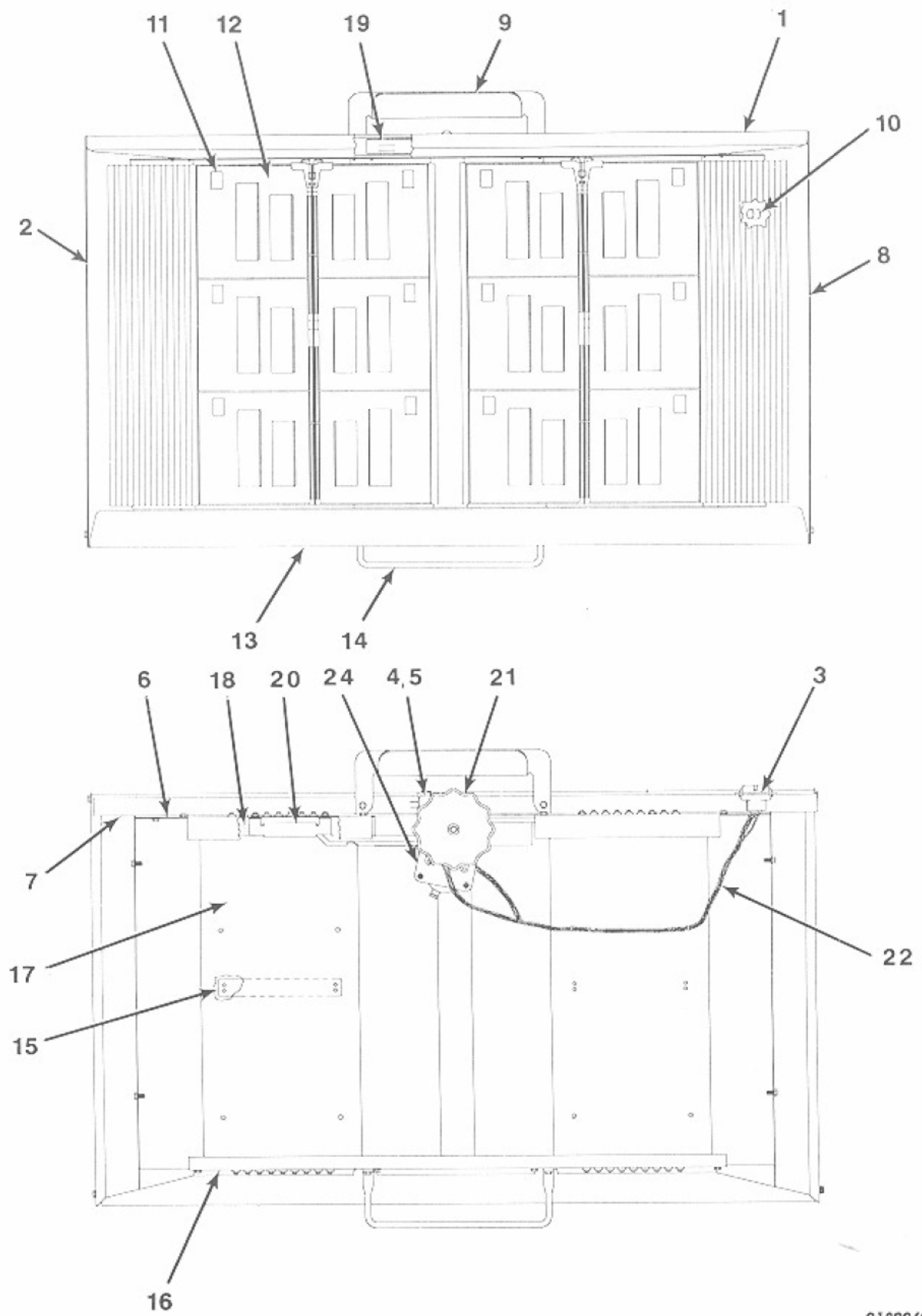

Ref.	Part No.	Description	Qty
	61060001	CD-100C Phonograph Assembly	Ref.
	61062701	Title Rack Assembly	1
1	61062401	• Diffuser - Light (Upper)	1
2	61062201	• Trim - Side (LH)	1
3	30938301	• Plate - Connector	1
4	21083001	• Nut - Twin	1
5	21942201	• Switch - Micro	2
6	61036702	• Plate - Top	1
7	40835302	• Brace - Mounting	1
8	61062301	• Trim - Side (RH)	1
9	30941802	• Handle - Titrack	1
10	30940801	• Bumper - Page	4
11	40835401	• Strip - Page Numbers	1
12	30933901	• Page and Clip Assembly	18
13	40855301	• Diffuser - Light (Lower)	1
14	30941801	• Handle - Titrack	1
15	40834701	• Guide - Center Page	1
16	61036802	• Plate - Bottom	1
17	61036903	• Support - Vertical (Titrack)	1
18	40833802	• Rack - CD Title Page	2
19	30940002	• Label - Warning (Narrow)	1
20	30935501	• Guide - Side CD Page Assembly	2
21	40848301	• Knob	1
22	30938501	• Harness Assembly - Interconnect	1
23	30935001	• Guide - Center (CD Page Assembly) (Not Shown)	1
24	30936301	• Motor and Gear Assembly	1
25	40855401	• Filter - Color (Decal) (Not Shown)	1
	30935904	• Blank - Title Strip (without numbers)	15
	30940601	• Filler - Title Page	8
	30935903	• Blank - Title Strip	15

Figure 8 - 6 CD-100C Phonograph Internal View

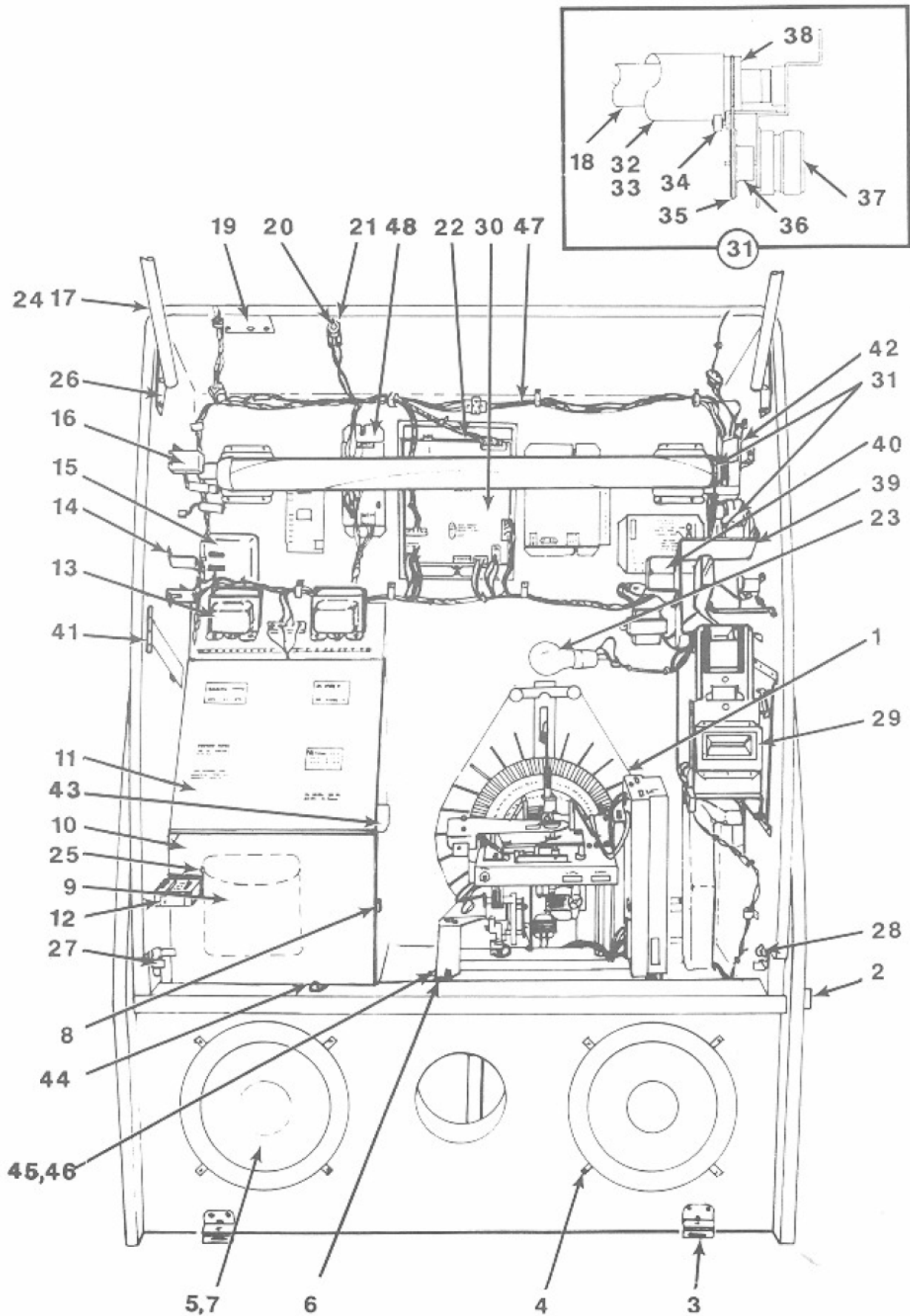
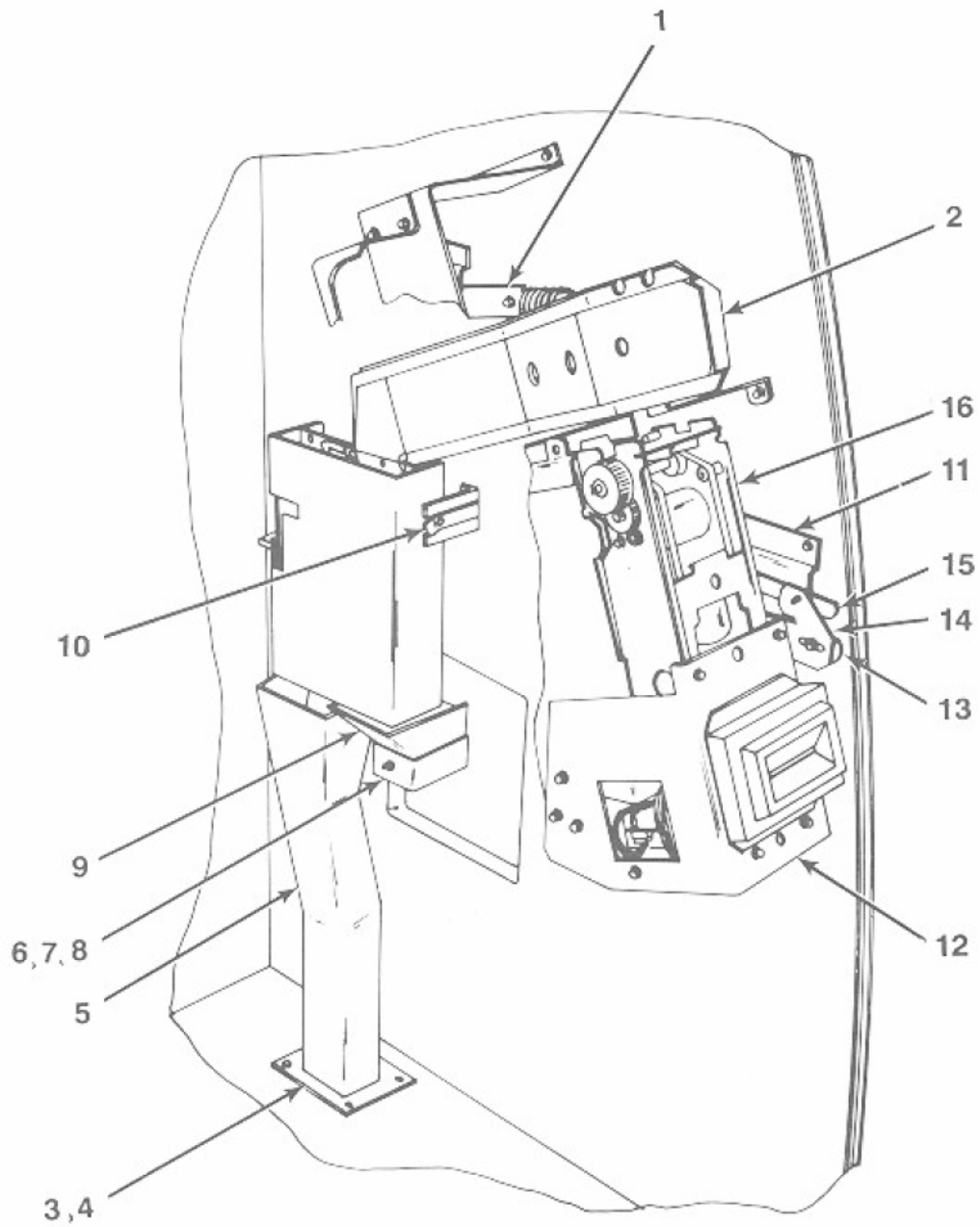

Figure 8-6 CD-100C Phonograph Internal View

Ref.	Part No.	Description	Qty
	61060001	CD-100C Phonograph Assembly	Ref.
1	61047801	• Mechanism - CD (Conv) (see figure 8-20)	1
2	21491301	• Guide - Door	4
3	30952301	• Bracket - Door Mounting	2
4	21780701	• Bracket - Retainer	8
5	21780610	• Pad - Acoustical (Not Shown)	1
6	21153701	• Support - Spring (Lower)	4
7	40731002	• Speaker - Low Frequency	2
8	21751804	• Catch - Title Panel	2
9	30869801	• Handy Case	1
(For a list of items included in the Handy Case, with part numbers, refer to Table 8-1, Accessory Equipment, at the end of this section)			
10	30962701	• Panel Assembly - Amplifier	1
11	40854901	• Panel Assembly - Amplifier (Top)	1
12	61060901	• Harness & Switch Assembly	1
13	40832101	• Transformer Assembly	1
14	30938101	• Bracket - Mounting (Upper LH)	1
15	21759301	• Cover - Cord Hole	1
16	40854701	• Bracket - Mounting (Lamp LH)	1
17	40714908	• Spring - Pneumatic	2
18	70060112	• Lamp - Flourescent (30 W T-8)	1
	70080004	• Starter - Flourescent (FS-4)	1
19	30936601	• Bracket - Guide (Hinge)	2
20	25060401	• Switch - Pushbutton (Momentary)	1
21	30956201	• Bracket - Switch	1
22	30956601	• Plate - Shield	1
23	70060423	• Lamp - Global (Inside Frosted)	1
24	30956301	• Support - Door	1
25	21870001	• Snap - In Fastener	2
26	21920302	• Plate Assembly - Pivot	2
27	21712701	• Latch Assembly - LH	1
28	21712801	• Latch Assembly - RH	1
29	65093004	• CBA-2 Transport Assembly (See figure 8-8)	1
30	40832201	• Central Control Computer	1
31	Ref.	• Color Tube Assembly	Ref.
32	30954201	• • Tube - Color	1
33	61061201	• • Filter - Color	1
34	21961701	• • Wheel & Bracket Assembly	1
35	21897301	• • Belt - O - Ring	1
36	21897401	• • Pulley	1
37	40824302	• • Motor & Harness Assembly	1
38	30953901	• • Cap - End (Color Tube)	1
39	30966701	• Bracket - Support	1
40	30938201	• Bracket - Mounting (Upper RH)	1
41	30962801	• Bracket Assembly - Titlerack	1
	21965501	• Velcro - Hook	1
	21965502	• Velcro - Loop	1
42	40854801	• Bracket - Mounting (Lamp RH)	1
43	30966601	• Stop / Catch - Titlerack	1
44	21730001	• Hook - Fall Stop	2
45	30932101	• Bracket - Mech Tie Down	2
46	30932201	• Lever - Mech Release	2
47	40854301	• Harness Assembly 100 v, 60 Hz	1
47	40854302	• Harness Assembly 100 v, 50 Hz	1
48	40856101	• Title Rack/Keyboard Interface	1

Figure 8-7. Coin Chute Assembly



Ref.	Part No.	Description	Qty
	61060001	CD-100C Phonograph Assembly	Ref.
1	30967301	• Scavenge Assembly	1
	30965601	• • Support - Scavenge (Large)	1
	30930902	• • Pivot - Scavenge	1
	30964501	• • Actuator	1
	21940601	• • Link - Scavenge (Pivot)	1
	30964301	• • Link - Scavenge	1
	21765601	• • Spring - Compression	1
	30965501	• • Support - Scavenge (Small)	1
	20922502	• • Spacer	6
	70091702	• • Lug - Solder	1
	21256201	• • Spring - Tension	1
	25156904	• • Washer - Shoulder	1
	25155901	• • Bumper - Split Stem	1
	70121701	• • Spacer	1
2	40854501	• Chute Assembly - Coin	1
	40855901	• • Back - Coin Chute (Upper)	1
	61062801	• • Chute - Coin (Upper)	1
	30963901	• • Bracket - Mounting (Coin Chute)	1
	30964201	• • Bracket - Mounting (Coin Chute)	1
3	30743701	• Collar - Coin (Lower)	1
4	21754401	• Gasket - Coin Chute	1
5	61060801	• Chute - Coin (Lower)	1
6	30781702	• Cup - Slug (Black)	1
7	21793001	• Bracket - Slug Cup	2
8	21792901	• Door - Slug Cup (Not Shown)	1
9	40856301	• Chute - Slug	1
10	21429501	• Catch Assembly - Rejector	1
	21790102	• Support - Hinge	1
11	30965201	• Support Assembly - B.A.	1
12	30965101	• Bracket Assembly Mounting (BA)	1
13	30858802	• Bar Assembly - Slide	1
14	30965301	• Bracket Assembly - Stop/Catch	1
15	30965001	• Latch - B.A.	1
16	65093004	• Transport - CBA-2	1
	40823101	• Power Supply CBA (Not Shown)	1
	40854001	• Inlet - Bill (Not Shown)	1
	21892605	• Label - Bill Insertion (Not Shown)	1

Figure 8-8. CBA-2 Bill Acceptor Assembly

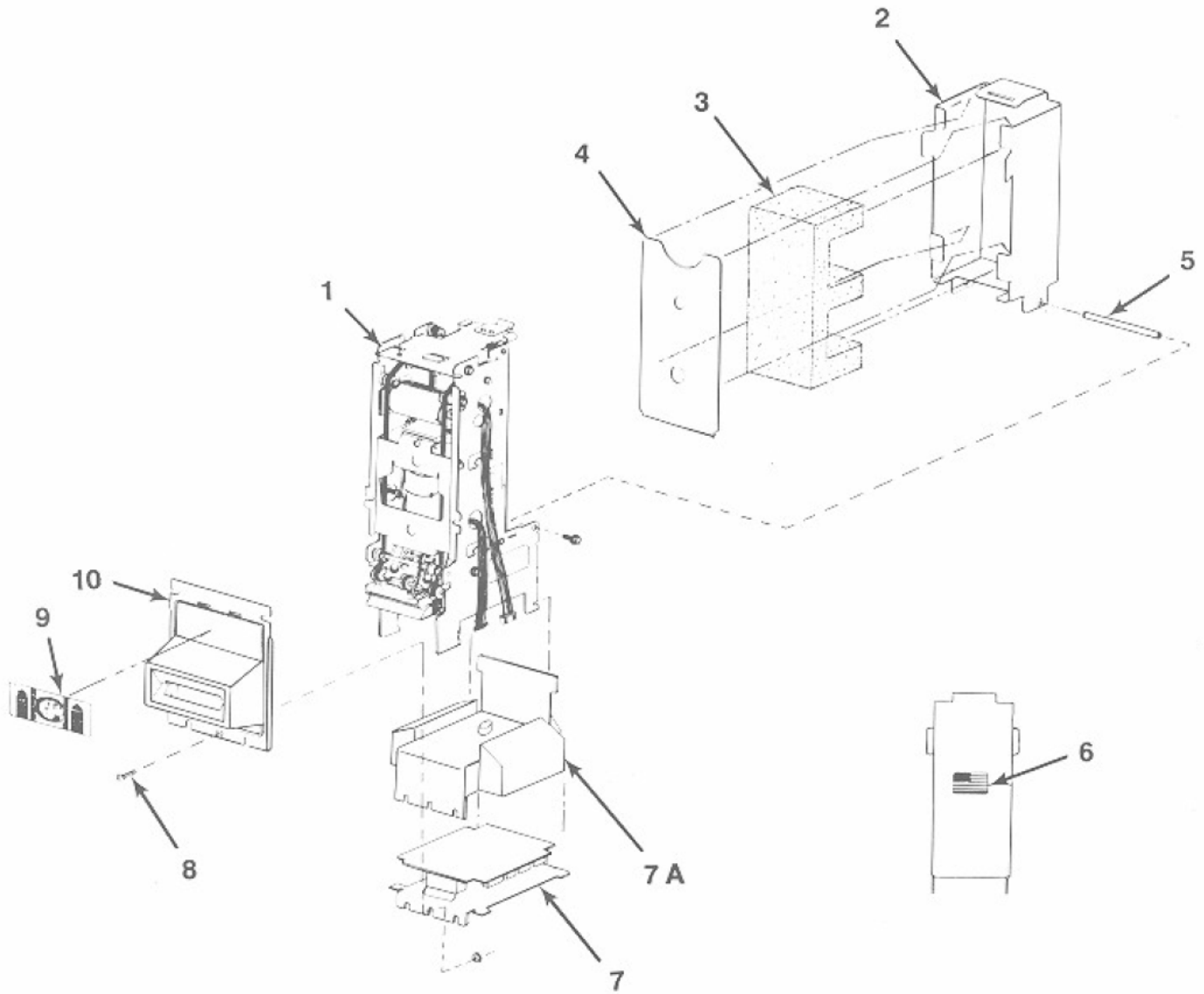

Ref.	Part No.	Description	Qty
1	65093004	• CBA-2 Transport Assembly	1
2	Ref.	• Bill Box	1
	45075101	• • 500 Locking Bill Box	
	65069501	• • 1000 Locking Bill Box	
3	Ref.	• Foam Block	1
	B0030702	• • Foam Block for 500 Bill	
	45078101	• • Foam Block for 1000 Bill	
4	35116401	• Pressure Plate	1
5	B0031942	• Bill Box Spacer Shaft	1
6	25223101	• Flag Label	1
7	B0030853	• Logic Board and Bracket Assembly (\$1 & \$5 Only)	1
7A	B0030819	• Water Shield	1
8	70134127	• Special Flat Head Screw	1
9	B0031988	• Bill Insertion Label	1
10	B0031953	• CBA-2 Tapered Bill Inlet	1

Figure 8-9. CBA-2 Transport Assembly

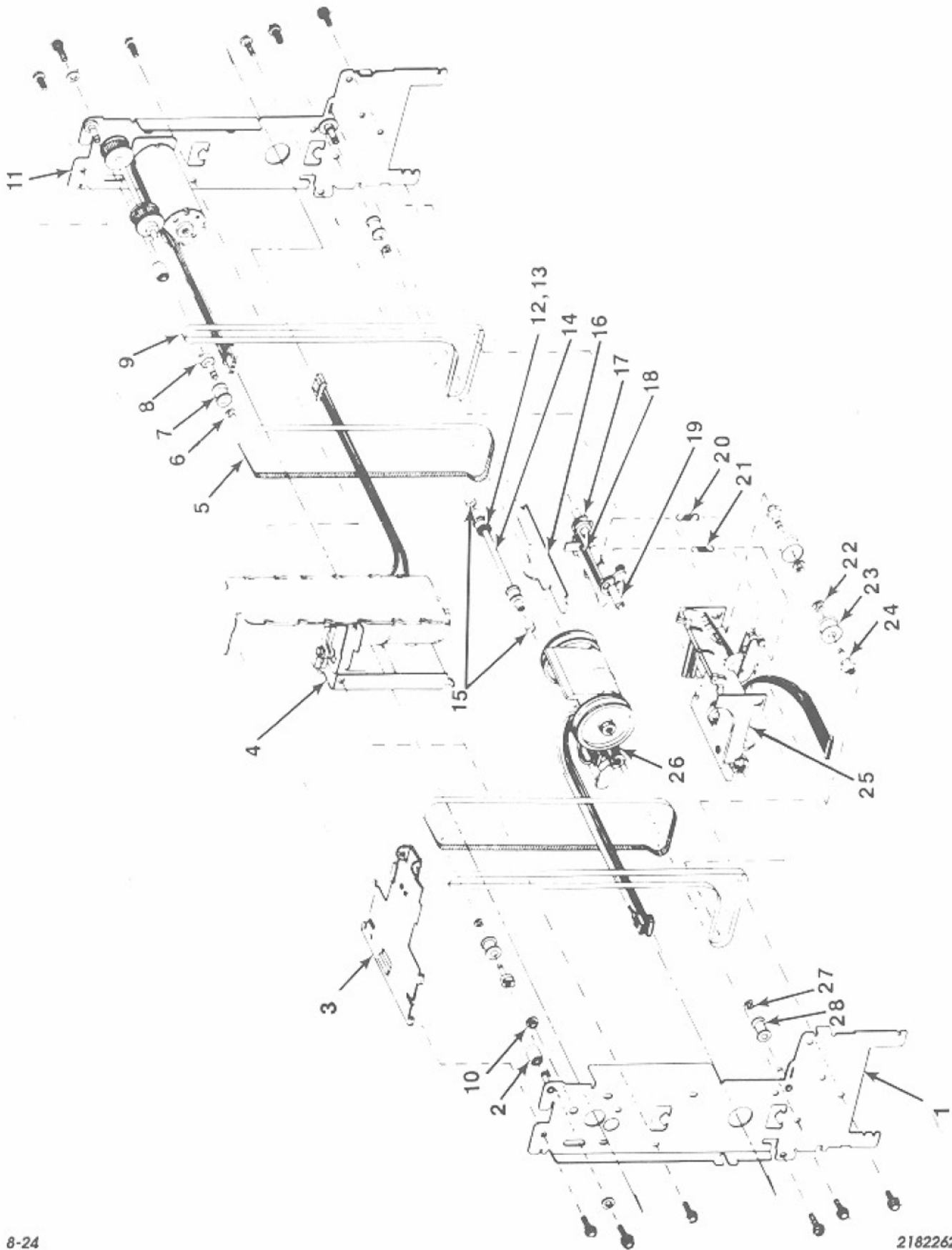

Ref.	Part No.	Description	Qty
	65070802	Generic CBA-2 (See figure 8-9)	
1	B0031952	• Right Hand Plate Assembly	1
2	25225501	• Crowned Roller	2
3	35117901	• Locking Latch Assembly	1
4	Ref.	• Stacker (See figure 8-14)	
5	B0031946	• Timing Belt	2
6	70143003	• External Retaining Ring	Ref.
7	35080302	• Flat Roller	Ref.
8	B0031937	• Flat Roller Pin	2
9	B0031956	• Drive Belt	2
10	70146003	• Nyliner Bearing	1
11	Ref.	• Motor and Gear Assembly (See figure 8-12)	
12	35080302	• Flat Roller	4
13	70143003	• External Retaining Ring	6
14	B0031930	• Flat Roller Shaft	1
15	B0030688	• Spacer	2
16	B0031925	• Bill Stop	1
17	70143004	• External Retaining Ring	2
18	45065801	• Anti-Cheat Lever	1
19	B0031941	• Anti-Cheat Lever Shaft	1
20	25223201	• Tension Spring (Yellow)	1
21	25223301	• Tension Spring (Blue)	1
22	70143003	• External Retaining Ring	Ref.
23	25193304	• Crowned Roller	2
24	B0031929	• Crowned Roller Pin	2
25	Ref.	• Lower Track (See figure 8-11)	
26	Ref.	• Upper Track (See figure 8-10)	
27	70143005	• External Retaining Ring	2
28	25225301	• Flanged Roller	2

Figure 8-10. Upper Track

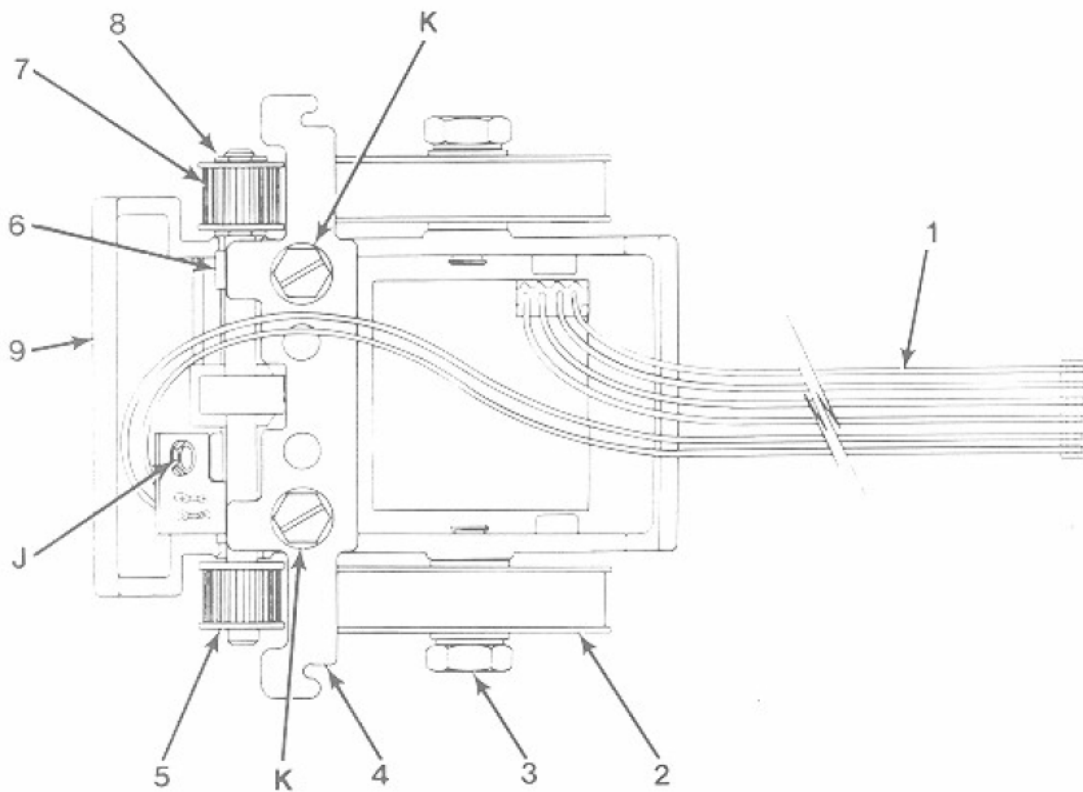

Figure 8-10 Upper Track

Ref.	Part No.	Description	Qty
	65070704	Upper Track	
1	45069002	• Upper Harness and Cell Assembly	1
2	35094601	• Drum Pulley	2
3	B0031924	• Pin	2
4	B0031922	• Upper Track Bracket	1
5	27038901	• Shaft and Pulley Assembly	1
6	25220401	• Split Bearing	1
7	35095102	• 16 -Tooth Pulley	1
8	70143005	• External Retaining Ring	2
9	B0031317	• Head and Track Assembly (Upper)	1

Figure 8-11. Lower Track

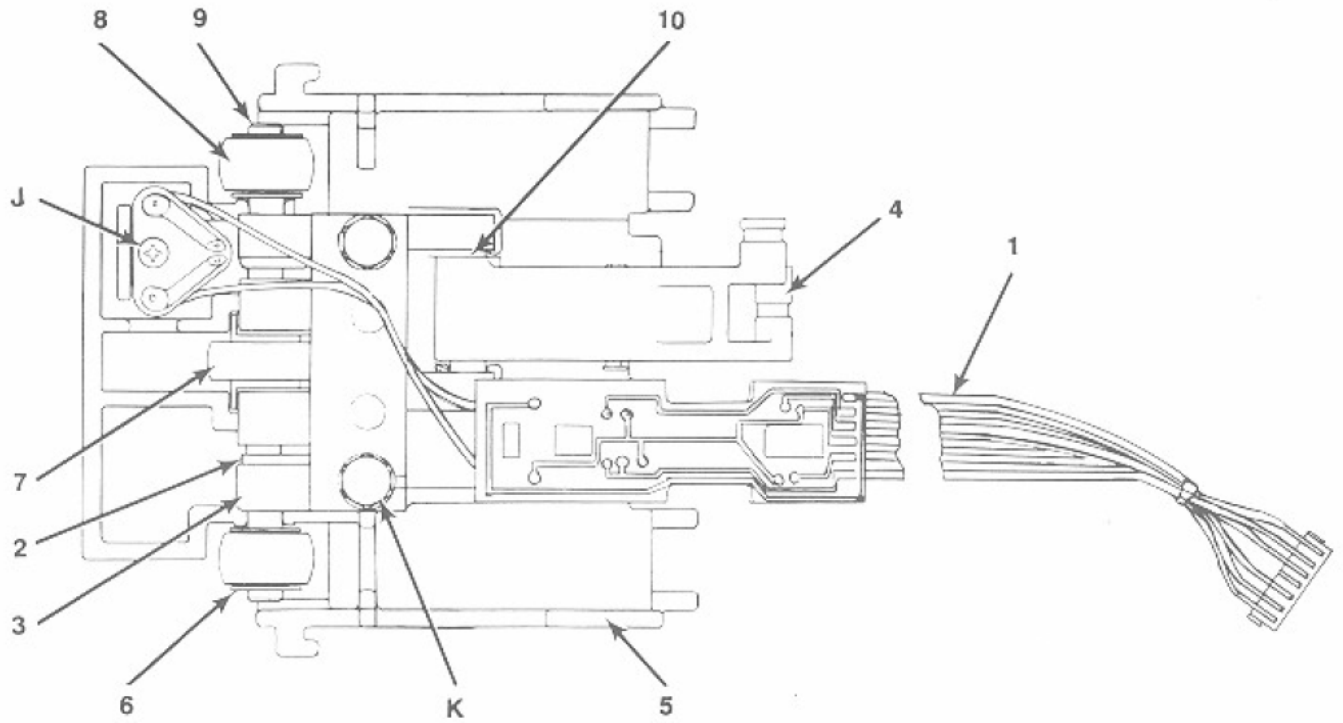

Figure 8-11. Lower Track

Ref.	Part No.	Description	Qty
	Ref.	Lower Track	
1	45073505	• Lower Harness and Cell Assembly	1
2	B0031927	• Input Shaft Spring	1
3	35111901	• Input Shaft Bracket	1
4	35117001	• Roller and Holder Assembly	1
5	B0031955	• Lower Track	1
6	70143003	• External Retaining Ring	4
7	25220701	• Input Roller	1
8	25193302	• Crown Roller	2
9	25220901	• Lower Input Shaft	1
10	B0031945	• Holder Pin	1

Figure 8-12. Motor and Gear Assembly

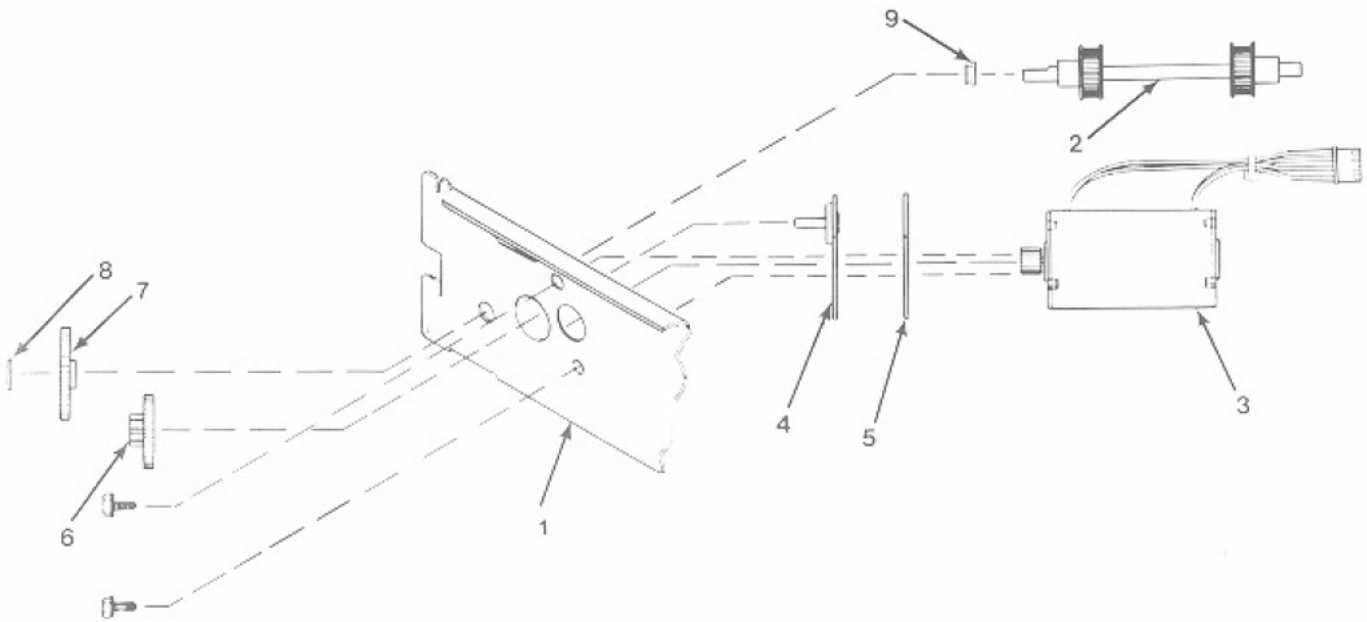

Figure 8-12. Motor and Gear Assembly

Ref.	Part No.	Description	Qty
Ref.		Motor and Gear	
1	B0031951	• Left Hand Plate Assembly	1
2	25244101	• Drive Shaft and Pulley Assembly	1
3	45058607	• Transport Motor Assembly	1
4	B0031974	• Transport Plate and Pin Assembly	1
5	B0031932	• Spacer Plate	1
6	B0031936	• Reduction Gear	1
7	B0031933	• Drive Gear	1
8	B0031944	• Retaining Ring	1
9	70146003	• Nyliner Bearing	1

Figure 8-13. Stacker Assembly

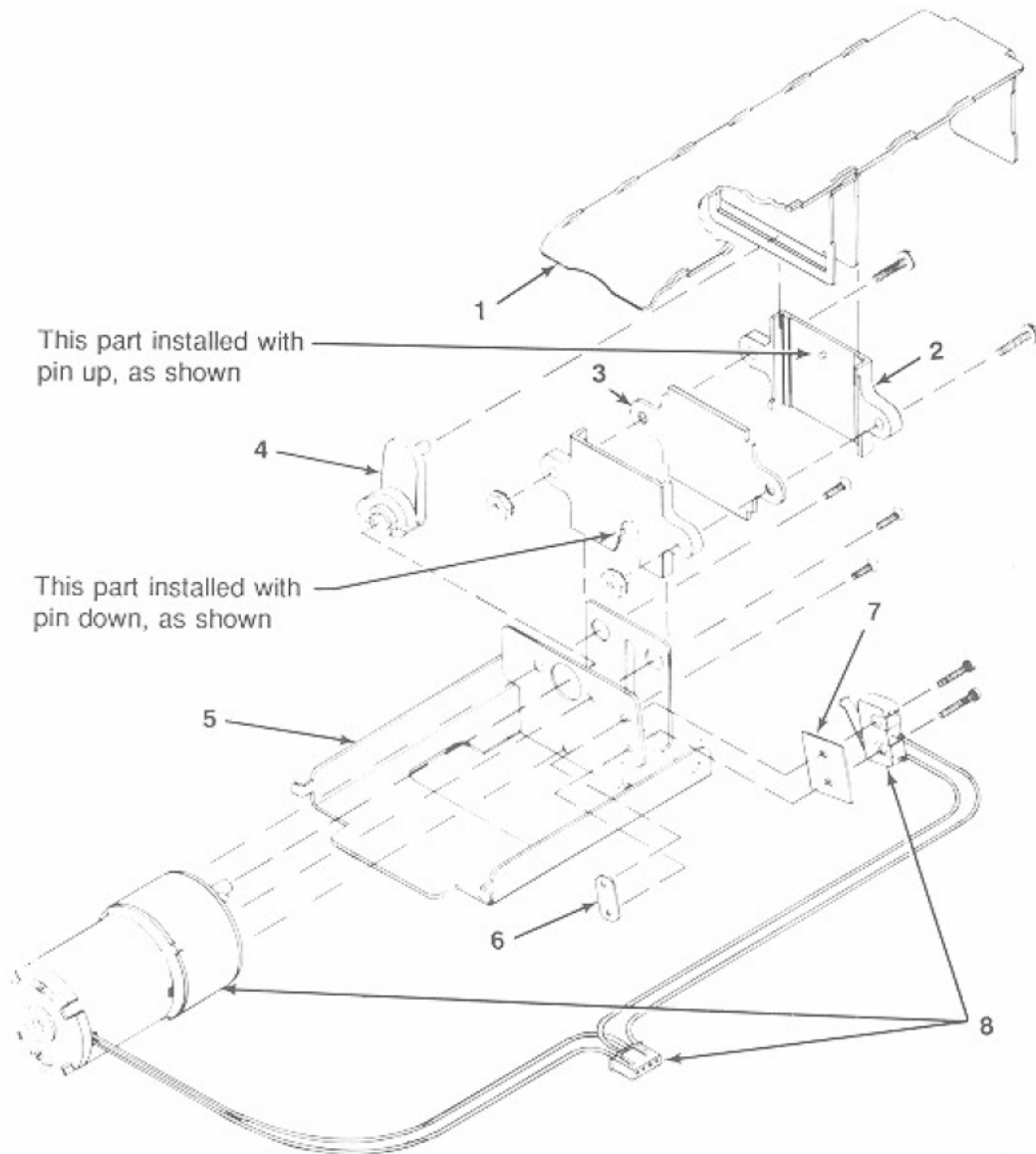

Figure 8-13. Stacker Assembly

Ref.	Part No.	Description	Qty
Ref.		Stacker	
1	B0031973	• Pusher Plate Assembly	1
2	B0031963	• Stacker Guide	2
3	B0031962	• Separator	1
4	B0031938	• Stacker Cam	1
5	B0031959	• Stacker Motor Bracket	1
6	B0030762	• Twin Nut	1
7	25222801	• Switch Separator	1
8	40791205	• Stacker and Motor Assembly	1
9	21630902	• Miniature Switch	1

Figure 8-14. CD-100C Amplifier Compartment

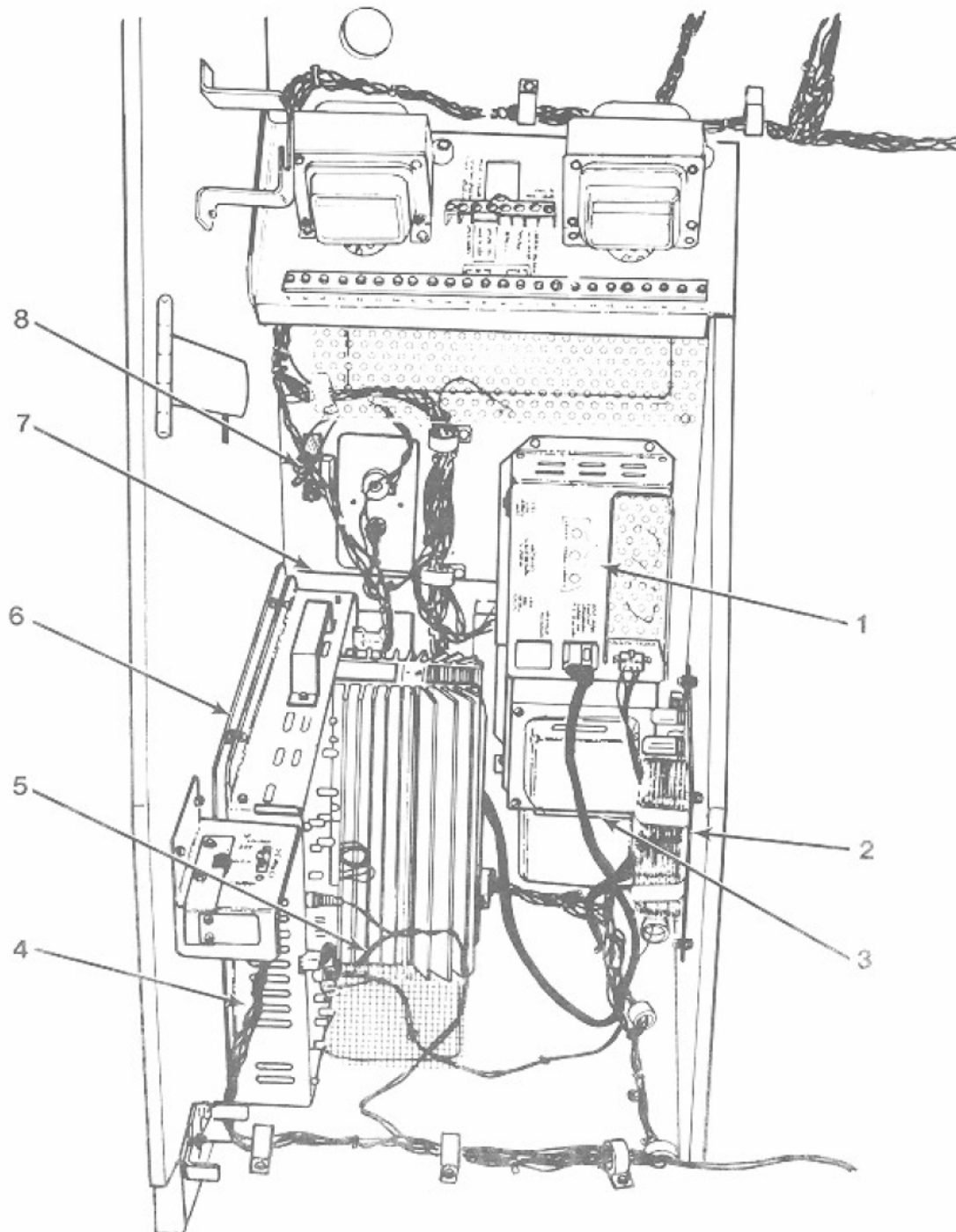
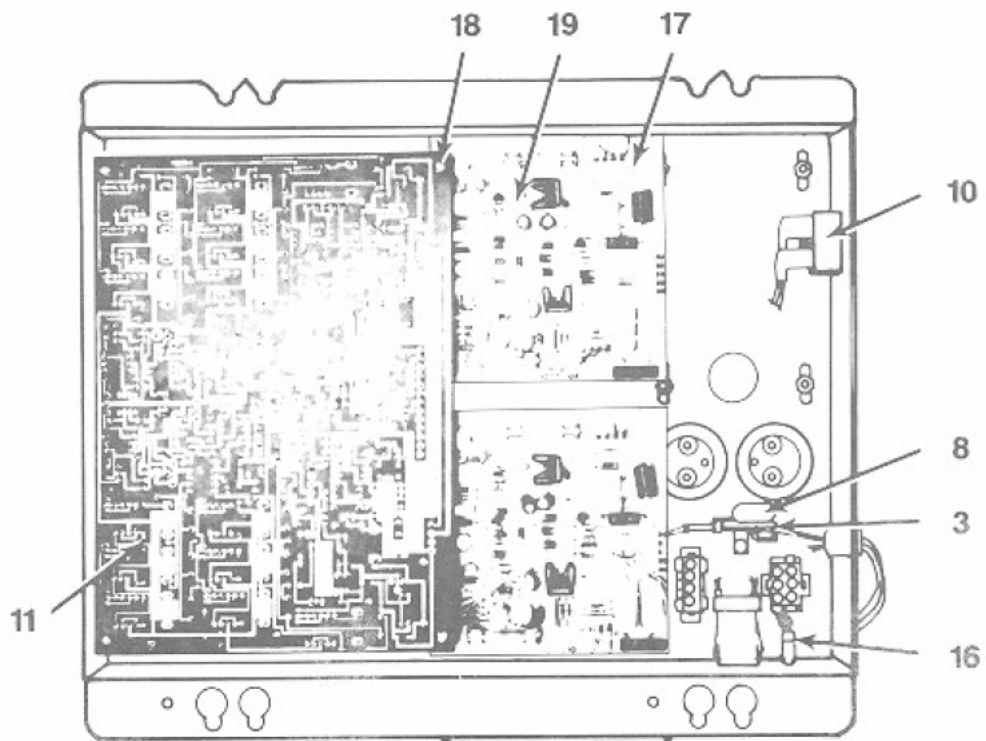
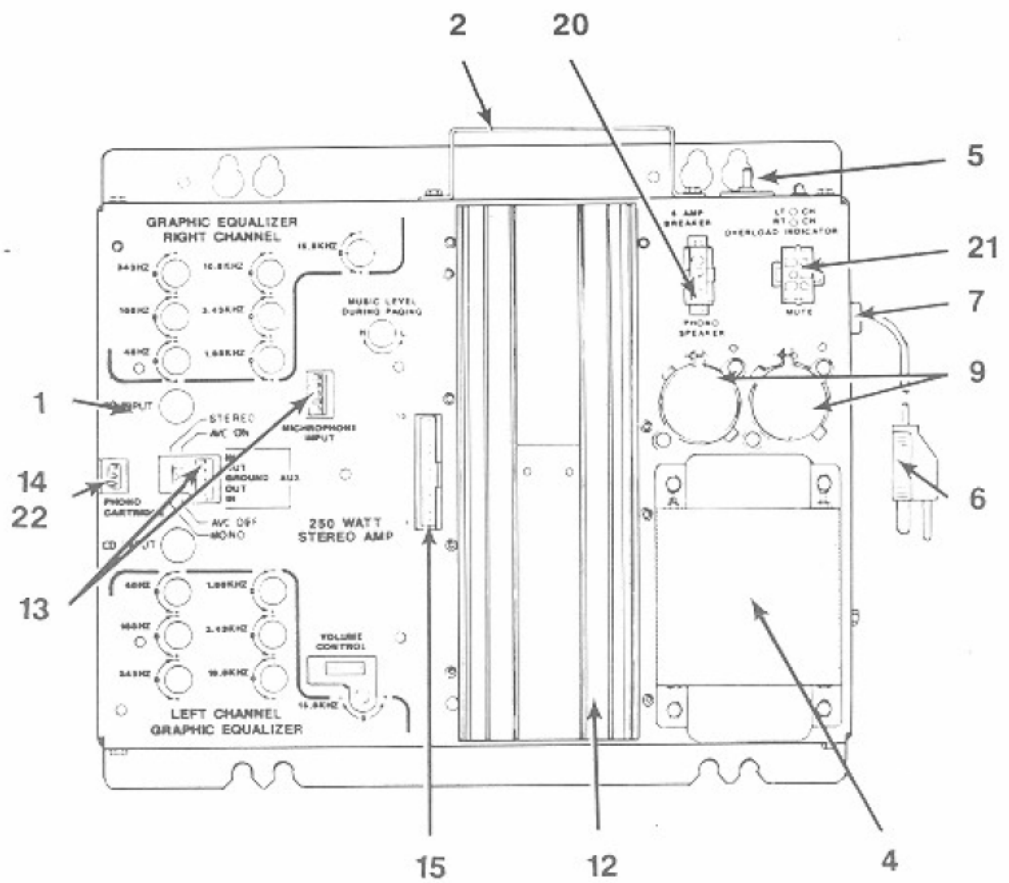

Figure 8-14. CD-100C Amplifier Compartment

Ref.	Part No.	Description	Qty
	61060001	CD-100C Phonograph Assembly	Ref.
1	40770609	• Main Power Supply (<i>see figure 8-18</i>)	1
2	61052701	• Circuit Board Assembly - Speaker Crossover	1
3	20925601	• Bracket - Mounting (Junction Box)	1
4	61024902	• 250 Watt Stereo Amplifier (<i>see figure 8-15</i>)	1
5	30934203	• Cable Assembly - Audio	1
6	40242601	• Mount Assembly - Amplifier	1
7	21967002	• Strap - Ground (CD-100C)	1
8	21955903	• Resistor - Assembly	1

Figure 8-15. Stereo Amplifier Assembly



Ref.	Part No.	Description	Qty
	61024902	Stereo Amplifier Assembly	Ref.
1	61024602	• Chassis Assembly	1
2	21488101	• Handle	1
3	21724102	• Terminal Strip	1
4	40737805	• Power Transformer	1
5	70078956	• Circuit Breaker	1
6	25218603	• 3 Conductor Cord and Plug	1
7	70232205	• Strain Relief	1
8	70021305	• Mylar Capacitor (.1 Mfd)	1
9	21823102	• Electrolytic Capacitor (10,000 Mfd)	2
10	21822501	• Bridge Rectifier	1
11	61023702	• Stereo Preamp. Assembly (<i>see schematic for parts list</i>)	1
12	40710303	• Heat Sink Detail (<i>see figure 8-16</i>)	1
13	70075505	• Connector Housing (5 Circuit)	2
14	70075503	• Connector Housing (3 Circuit)	1
15	21620703	• Amplifier Jumper Plug Assembly	1
16	21893401	• Speaker Overload Indicator (Left Channel)	1
	21893402	• Speaker Overload Indicator (Right Channel)	1
17	70500006	• Circuit Board Support	8
18	70500018	• Circuit Board Support	5
19	40710104	• Driver Circuit Board Assembly (<i>see power amplifier schematic for components list</i>)	2
20	30749003	• Cap Housing (4 Circuit)	1
21	30749004	• Cap Housing (6 Circuit)	1
	70097502	• • Contacts	6
22	21620704	• Shorting Plug	1
	70099201	• • Self - Stripping Terminal	1
	21943301	• • Capacitor Clamp	2
	70091706	• • Solder Lug	1
	70075505	• • Connector Housing (5 Circuit)	2
	70075502	• • Connector Housing (2 Circuit)	2
	70800101	• • Cable Tie	4
	70075601	• • Contact	9
	70091308	• • Terminal Lug - Slip On	2

Figure 8-16. Heat Sink Detail

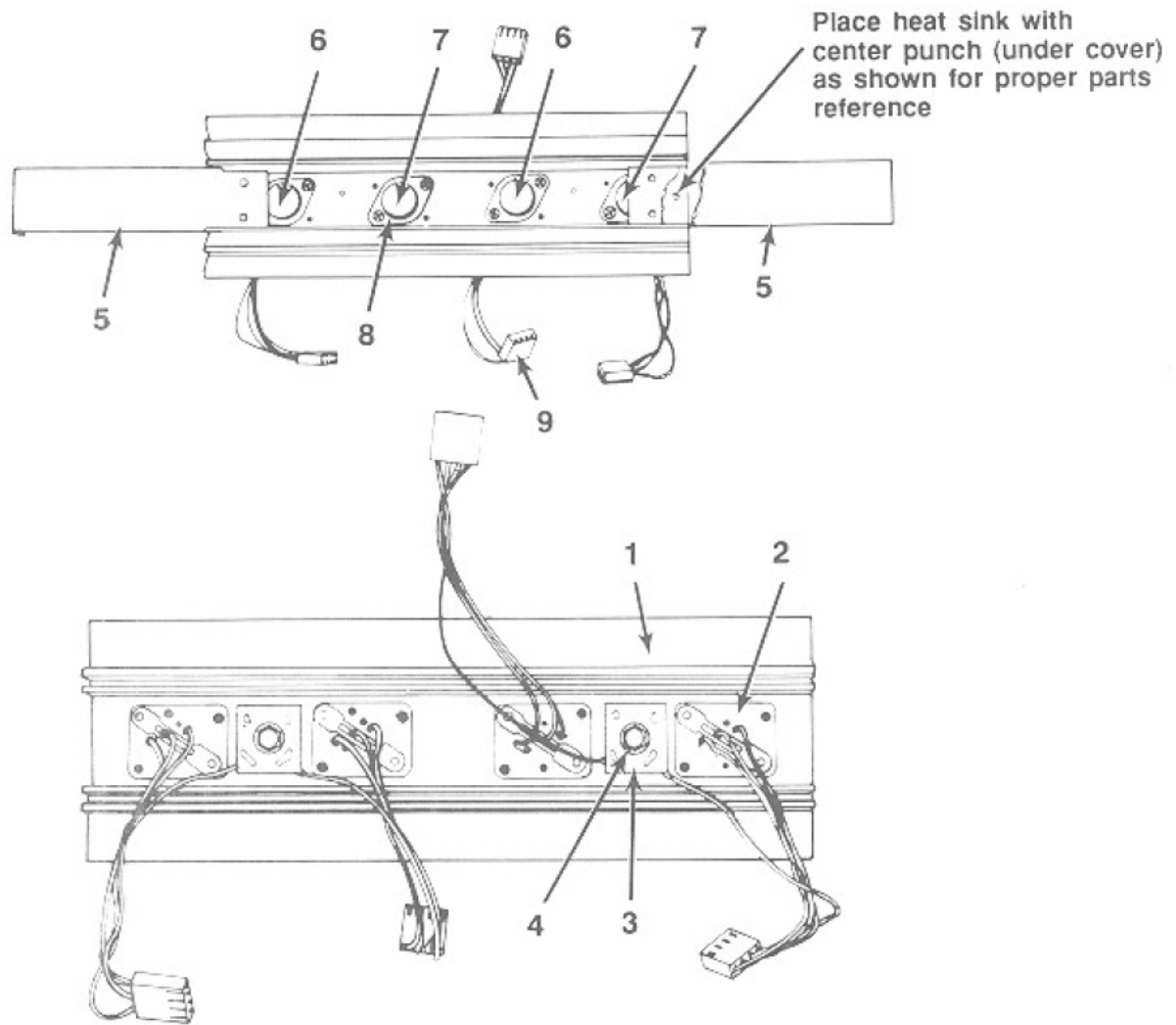

Figure 8-16. Heat Sink Detail

Ref.	Part No.	Description	Qty
1	40710303	• Heat Sink (<i>see figure 8-15, item 12</i>)	Ref.
2	21547301	• Power Transistor Socket	4
3	40837401	• Circuit Board Assembly - Bias Diode	2
4	21840201	• Compression Spring	2
5	21798001	• Cover	2
6	70030206	• Transistor (Darlington Amp, RCA- 2N6284) (NPN, Q101, 2 places)	2
7	70030207	• Transistor (Darlington Amp, RCA-2N6287) (PNP, Q102, 2 places)	2
8	21318902	• Precoated-Insulator	4
9	70075504	• Connector Housing	4

Figure 8-17. Output Transformer Assembly

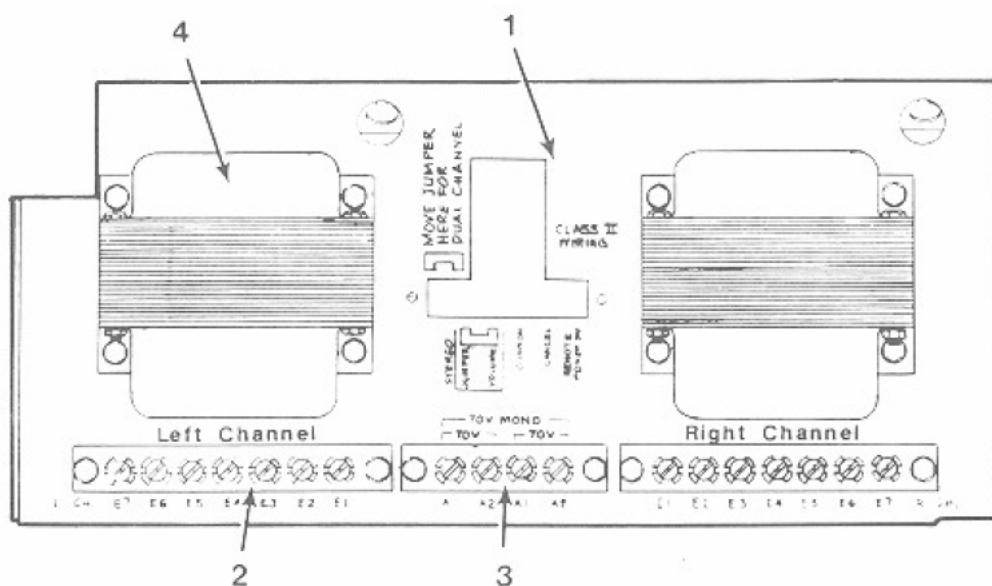
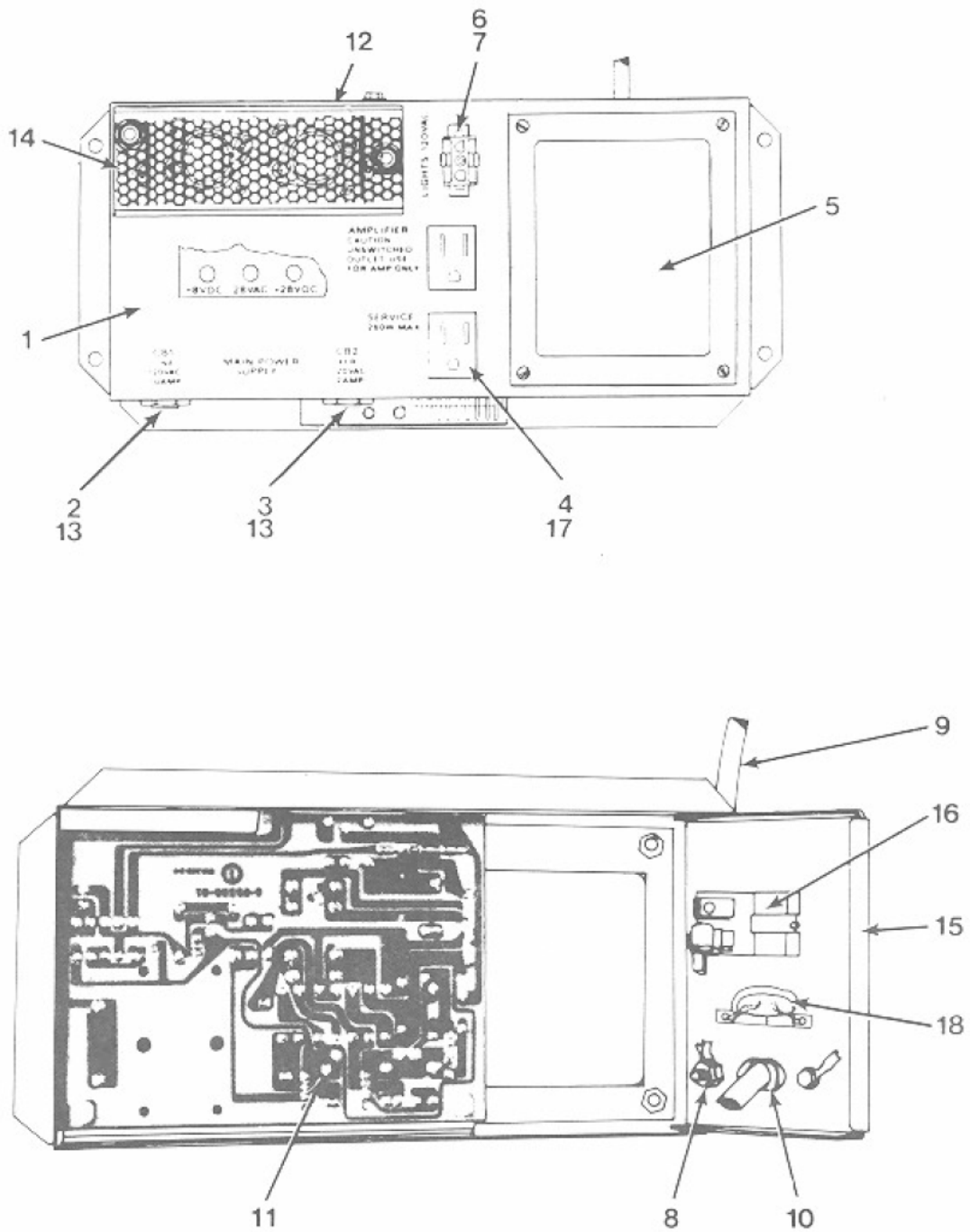

Figure 8-17. Output Transformer Assembly

Ref.	Part No.	Description	Qty
	40832101	Transformer Assembly (See figure 5-10, the Wiring Diagram)	
1	40832001	• Chassis With Lettering	1
2	30426707	• Terminal Strip	2
3	30426706	• Terminal Strip	1
4	40633502	• Output Transformer	2
5	21537401	• Label - Speaker Power	1

Figure 8-18. Main Power Supply

(120 Volt, 60 Hz Model)



Ref.	Part No.	Description	Qty
	40770610	Main Power Supply (120 V) Canada	Ref.
	46509214	Main Power Supply (100 V)	Ref.
	40770609	Main Power Supply (120 V) (see figure 8-14, item 1)	Ref.
	46509215	Main Power Supply (220 V)	Ref.
	46509216	Main Power Supply (240 V)	Ref.
1	40771905	• Chassis Assembly	1
2	70073613	• 10 Amp Circuit Breaker (120 V)	1
3	70073605	• 2 Amp Circuit Breaker (120 V)	1
4	21375901	• 3 Wire Convenience Outlet	2
5	40772001	• Transformer - Power (120 V)	1
	46509302	•• Transformer - Power (100/220/240 V)	1
	70075601	•• Post Contact (120 V)	6
	70075601	•• Post Contact (100/220/240 V)	5
	70097504	•• Contact	1
	70091308	•• Terminal Lug (120 V)	1
	70091308	•• Terminal Lug (100/220/240 V)	4
6	30749002	• Cap Housing	1
	70097504	•• Contact (100/220/240 V)	3
7	70097504	• Contact (120 V)	2
	70091308	•• Terminal Lug (120 V)	2
	70091308	•• Terminal Lug (100/220/240 V)	4
8	70091511	• Ring Terminal (120)	2
9	30834506	• Power Cord Assembly (120 V)	1
	36536501	• Power Cord Assembly (100/220 V/240 V)	1
10	70232104	• Strain Relief	1
11	60935705	• Circuit Board Assembly - Main Power Supply	1
12	40733102	• Heat Sink and Power Transistor Assembly	1
	30834301	•• Power Supply Heat Sink	1
	70030807	•• Transistor (Darlington) (2N6055) (Motorola, RCA)	2
	21318902	•• Insulator	2
	25158602	•• Power Transistor Socket	2
	70075504	•• Connector Housing	2
	70075601	•• Post Contact	6
	70075702	•• Keying Post	2
13	21408602	• Straight Receptacle (120 V)	4
	21408602	• Straight Receptacle (100/220/240 V)	8
	70073608	• Breaker 100/220/240 V (5A) (Not Shown)	2
	70073610	• Breaker 100/220/240 V (7A) (Not Shown)	1
14	21828101	• Heat Sink Cover	1
15	30867301	• Switch Panel	1
	30867302	• Switch Panel (Canada)	1
	21870501	• Base - Switch Cover (Canada)	1
	21870601	• Switch Cover (Canada)	1
	25077201	• Toggle Switch - SPST (Canada)	1
	21724101	• Terminal Strip (100/220/240 V)	1
16	30785701	• Rocker Switch - SPST (120 V)	1
	30785702	• Rocker Switch - SPST (100/220/240 V)	1
17	70096701	• Insulated Faston (120 V)	1
	70096701	• Insulated (220/240 V)	1
	70099201	• Self Stripping Terminal	7
	70099101	• Self Stripping Terminal	1
	70075508	• Connector Housing	1
	70075702	• Keying Plug	1
	70075601	• Post Contact (120 V)	4
	70075601	• Post Contact (220/240 V)	5
18	21943801	• MOV Assembly (100/120 V)	1
	21943701	• MOV Assembly (220/240 V)	1

Figure 8-19. Central Control Computer

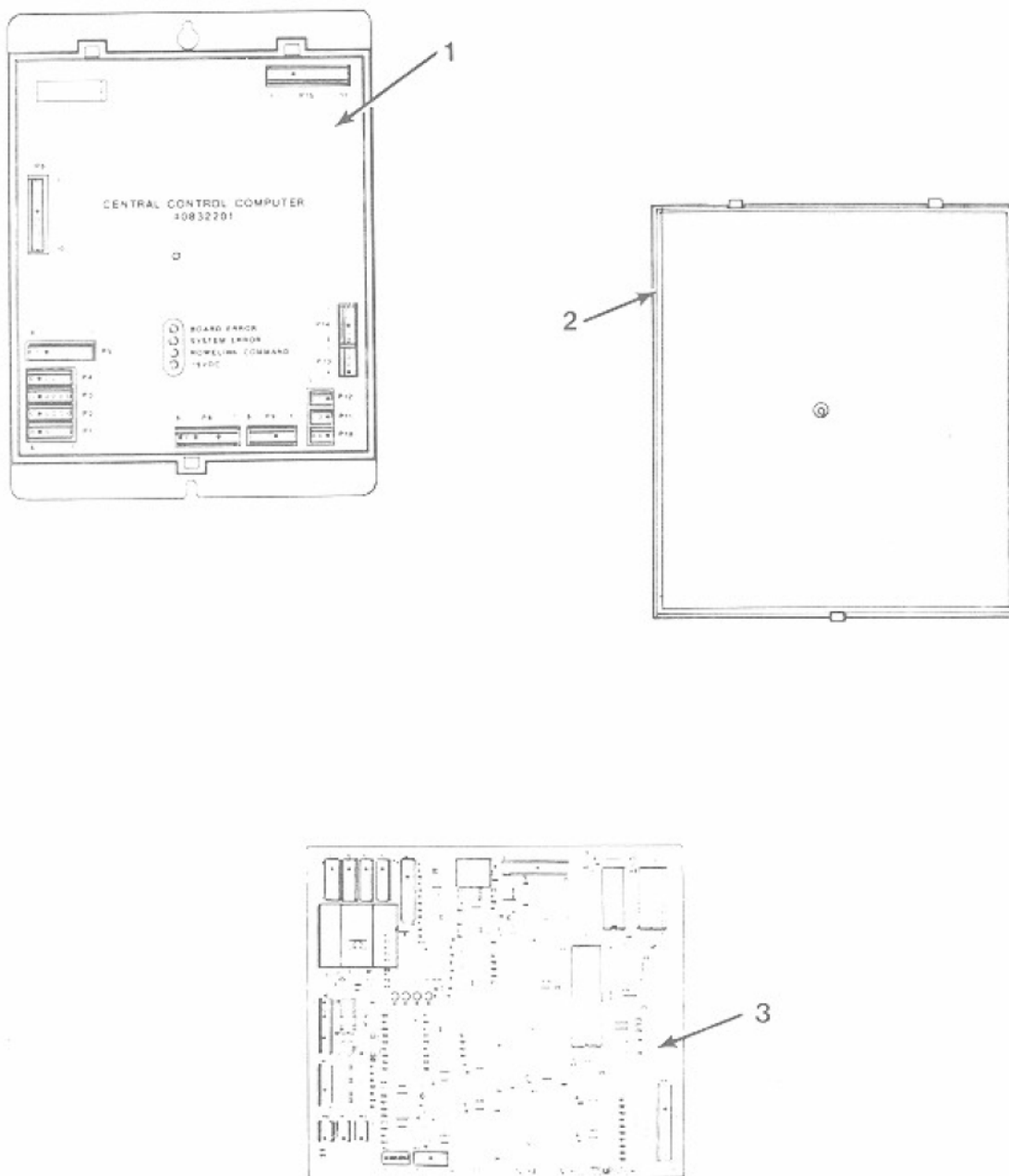
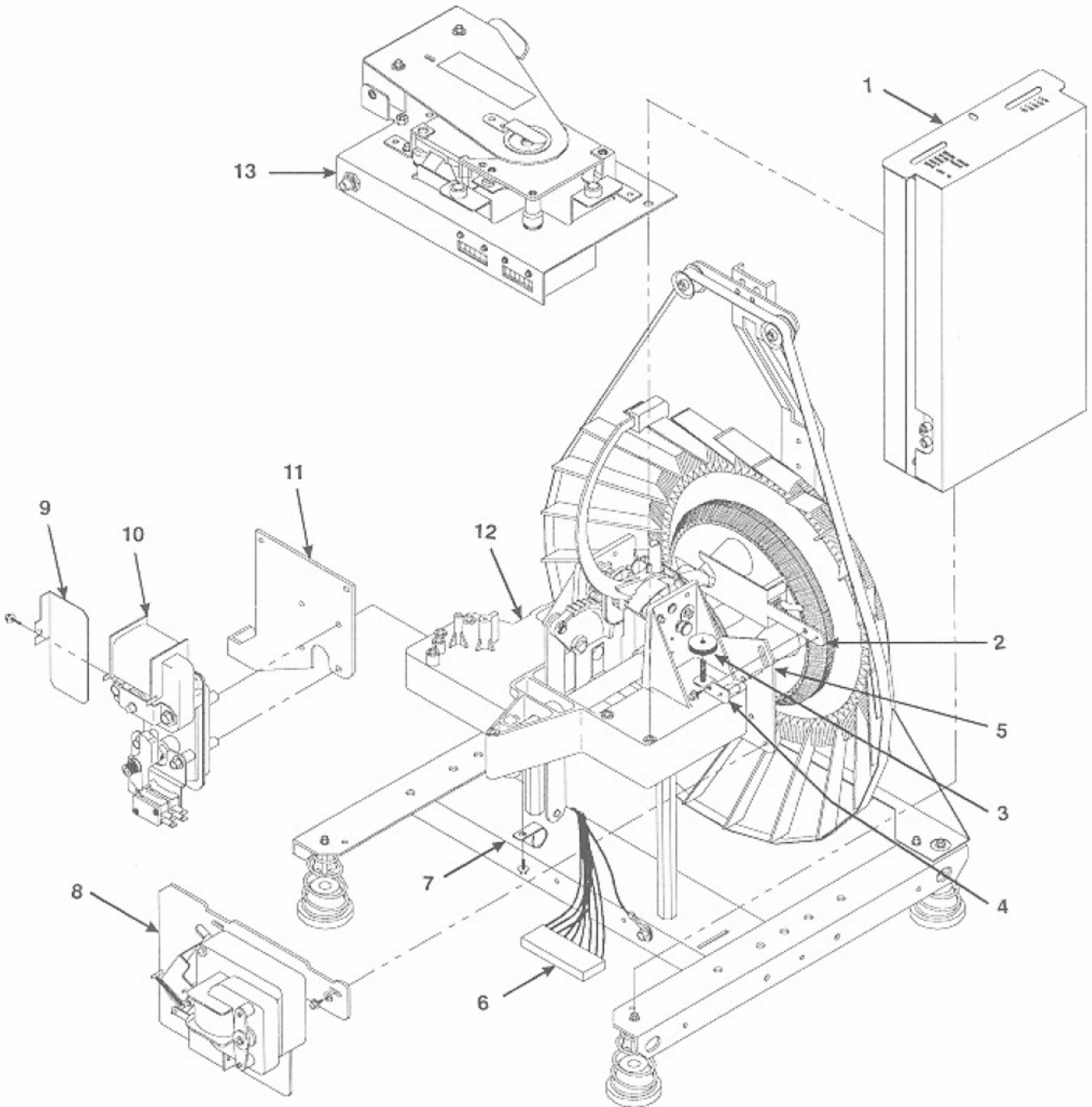

Figure 8-19. Central Control Computer Assembly

Ref.	Part No.	Description	Qty
	40832201	Central Control Computer Assembly (<i>see figure 8-6, item 30</i>)	Ref.
1	61031201	• Central Control Computer Cover	1
2	61031301	• Central Control Computer Base	1
3	61031101	• Central Computer Circuit Board Assembly (<i>see figure 5-12 for the schematic and components list</i>)	1

Figure 8-20. Mechanism Assembly

Sheet 1



Ref.	Part No.	Description	Qty
	61047801	CD Mechanism Assembly	Ref.
1	61048101	• Decoder & Mech Board Assembly	1
	30955501	• 4 Wire Harness	1
	30955601	• • 14 Wire Harness	1
	21959501	• • 15 Conductor Ribbon Wire	1
	61047901	• • Decoder Board	1
	40847801	• • Center Support Assembly (PWB)	1
	21962101	• • Support RCA Jack	1
	70121906	• • Hex Spacer (4-40 Thread)	4
	61053401	• • Mechanical Controller Board	1
	70500004	• • Plastic Standoff	1
	61054001	• • Cover-Decoder Board (Outside Cover)	1
	70233202	• • Snap Bushing	1
	61054101	• • Cover Mech. (Inside Mounting Cover)	1
2	30906801	• Switch Assembly Optical	1
	30905901	• • Optical Sw & Conn Assembly	1
	30794501	• • Bracket-Mtg (Optical Switch)	1
3	21818401	• Knob Adjusting	1
4	21818601	• Bracket Assembly Adjusting	1
5	40721801	• Plate Mounting (Intermediate)	1
6	40830003	• CD Harness Assembly	1
7	20554502	• Clip Cable	1
8	40721901	• Sprag Assembly (<i>See figure 8-21</i>)	1
9	30946901	• Shield-Oil Spray	1
10	40720802	• Cam Switch & Motor Assembly (<i>See figure 8 - 22</i>)	1
11	30790701	• Plate Motor Mounting	1
12	60870703	• Base-Mechanism (CDM-4)	1
13	61048001	• Plate Assembly-Mounting (CDM-4)	1

Figure 8-20. Mechanism Assembly

Sheet 2

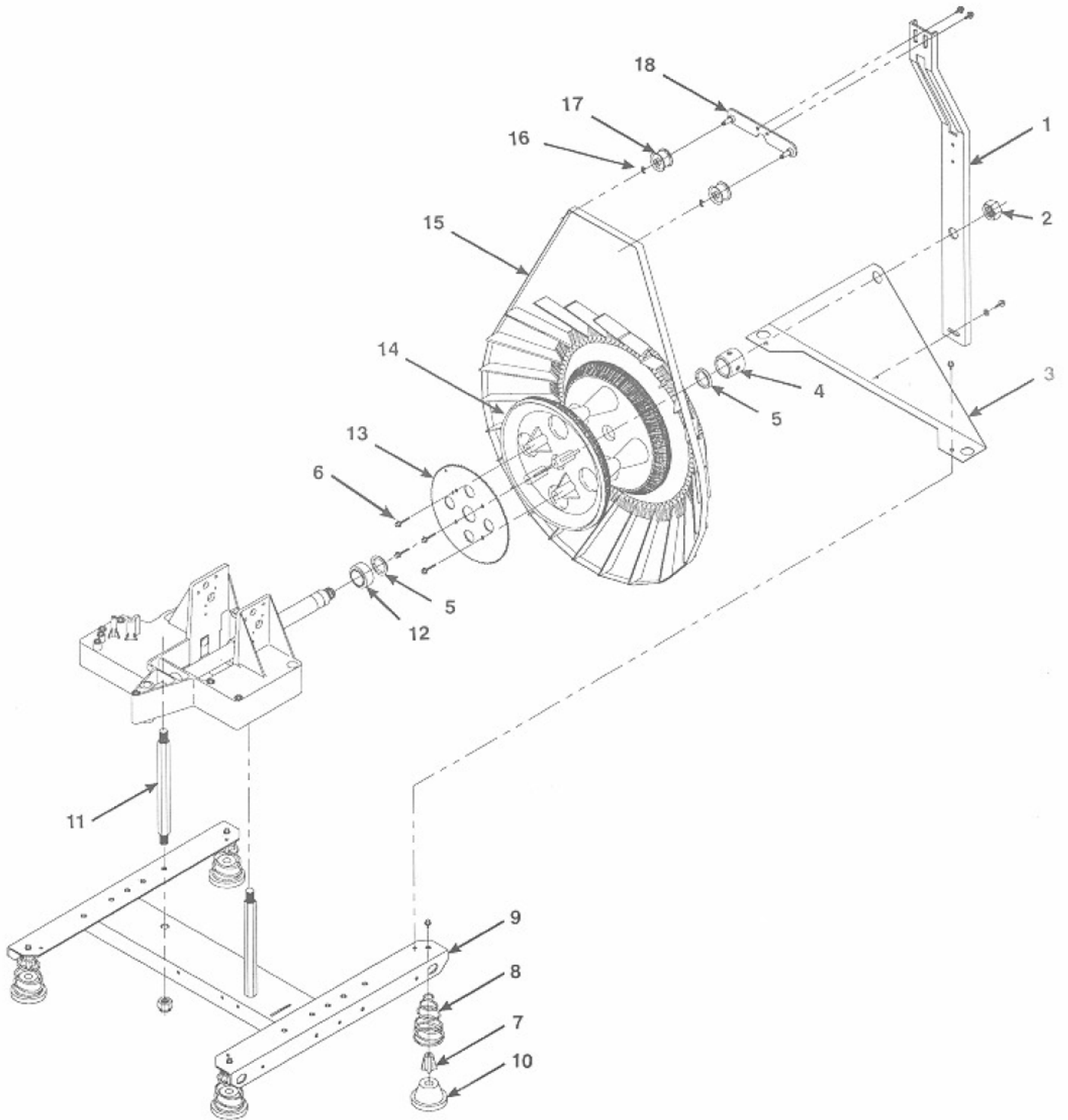

Ref.	Part No.	Description	Qty
	61047801	CD Mechanism Assembly	Ref.
1	40721303	• Guide Assembly-Gripper Bow	1
2	70130109	• 9/16-18 Jam Nut	1
3	61052901	• Support Rear	1
4	21812601	• Collar	1
5	70146001	• Bearing Nyliner	2
6	86663612	• #8-32 X 3/4 HWRHS Type 17 Screw - Special	4
7	20627202	• Support Spring (Upper)	4
8	20612804	• Spring	4
9	30791502	• Support Assembly Mech	1
10	21153701	• Support Spring (Lower)	4
11	21812501	• Support-Mechanism	2
12	25156906	• Washer-Shoulder	1
13	30790401	• Gear-Magazine	1
14	61045801	• Magazine Assembly-CD	1
15	21813802	• Belt	1
16	70143003	• Ring-External Retaining	2
17	20384301	• Roller-Belt	2
18	21089401	• Bracket Assembly-Roller	1

Figure 8-20. Mechanism Assembly

Sheet 3

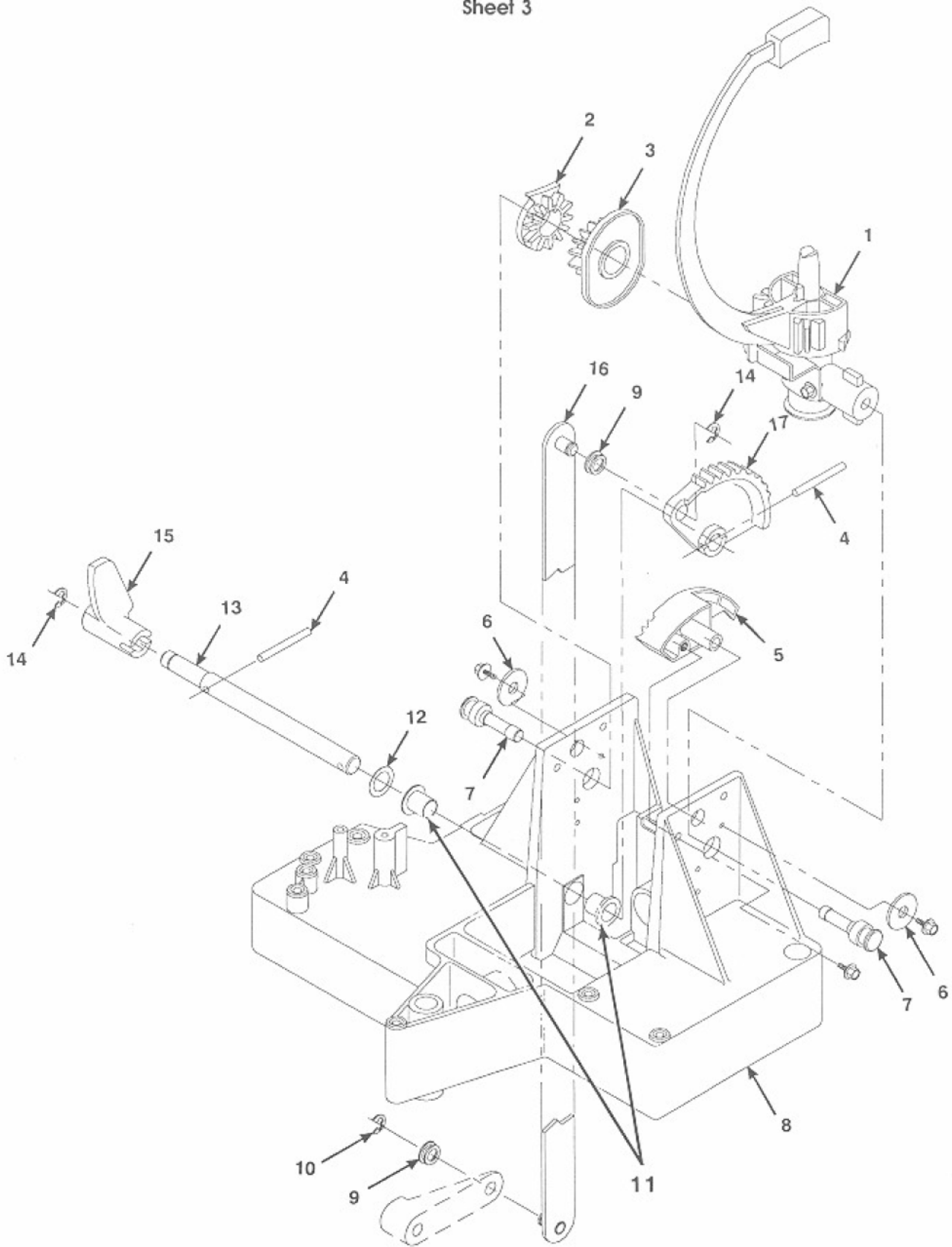

Ref.	Part No.	Description	Qty
	61047801	CD Mechanism Assembly	
1	40720701	• Gripper Bow & Trunnion Assembly	1
2	40720401	• • Gear - Cam	1
3	40720601	• • Gear - Trunnion	1
4	70113003	• • Pin - Roll .131/.135 x 11/16	2
5	30790603	• Rotator Assembly	1
6	70120010	• Washer	2
7	21079202	• Pin - Trunnion	2
8	60870703	• • Base - Mechanism (CDM-4)	1
9	70146004	• • Bearing - Nyliner	2
10	70143004	• • Ring - External Retaining	2
11	70146005	• • Bearing - Nyliner	2
12	70122533	• • Washer - Bowed	1
13	21813202	• • Cam Drive Shaft	1
14	70143010	• • Ring - External Retaining	1
15	30930002	• • Cam - Hold Down	1
16	21810201	• • Link Assembly - Transfer	1
17	40720502	• • Gear - Sector	1

Figure 8-20. Mechanism Assembly

Sheet 4

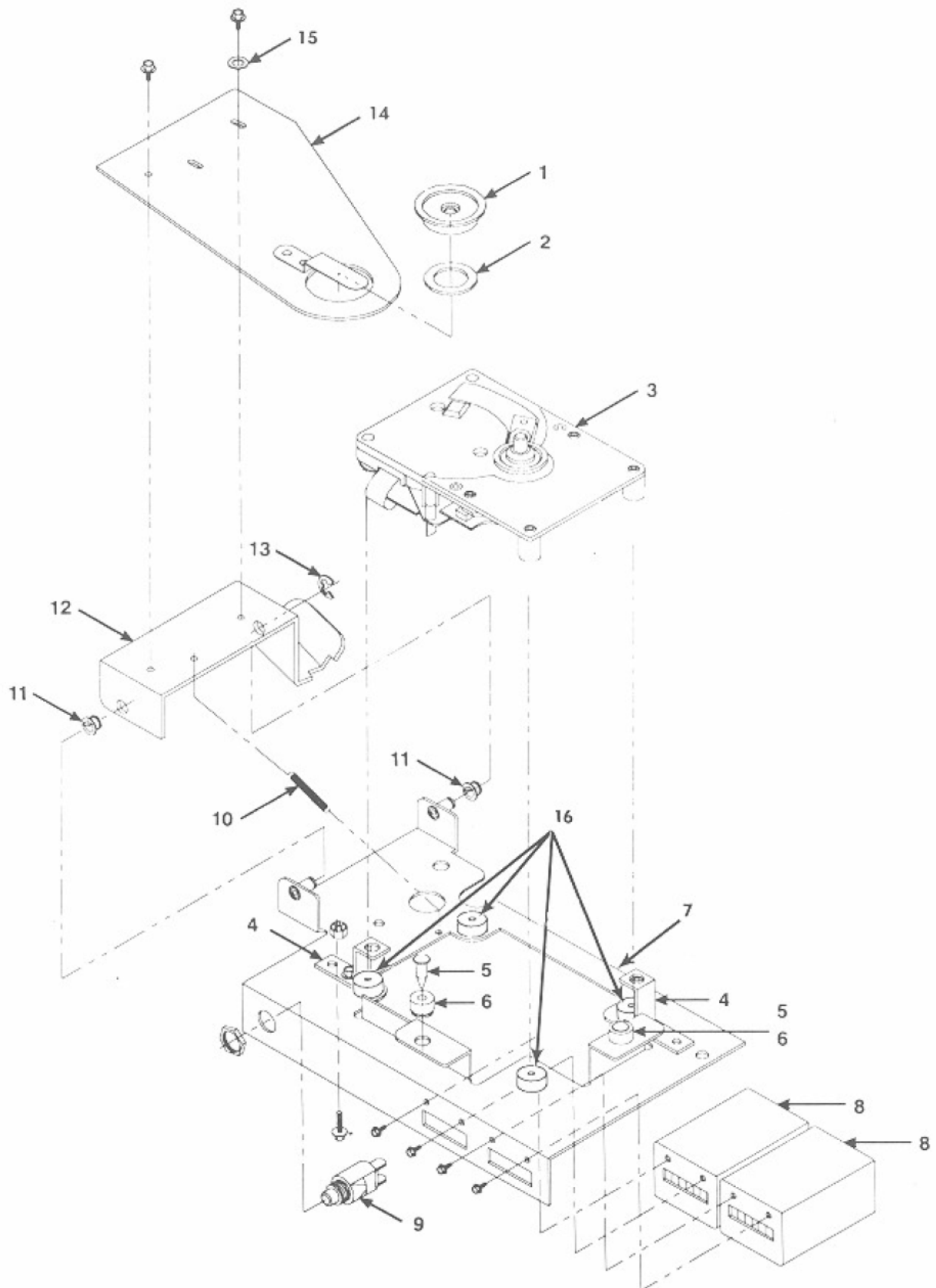

Ref.	Part No.	Description	Qty
	61047801	CD Mechanism Assembly	
1	21960101	• Magnetic Hub Assembly	1
	30930401	• • Magnet Ring (Hold Down)	1
2	21960201	• Washer-Traction	1
3	30955401	• Industrial CDM-4 Player W/Guide Pin	1
4	21961201	• Bracket Lockdown	2
5	20930007	• Rivet-Accordian	2
6	21813901	• Grommet	2
7	61048001	• Plate Assembly-Mounting (CDM 4)	1
8	30933301	• Counter & Plug Assembly	1
	21538302	• • Counter (Money)	1
	21441802	• • Counter-Electric (Play)	1
9	21581801	• Switch-Pushbutton (Momentary) with Nut	1
10	21095501	• Spring-Tension	1
11	70146004	• Bearing Nyliner	1
12	40847501	• Hinge-Hold Down (CDM-4)	1
13	70143004	• Ring-External Retaining	1
14	30954701	• Plate Assembly-Hold Down	2
15	70120019	• Washer	2
16	21940101	• Grommet - Shock Mount	4

Figure 8-21. Sprag Assembly

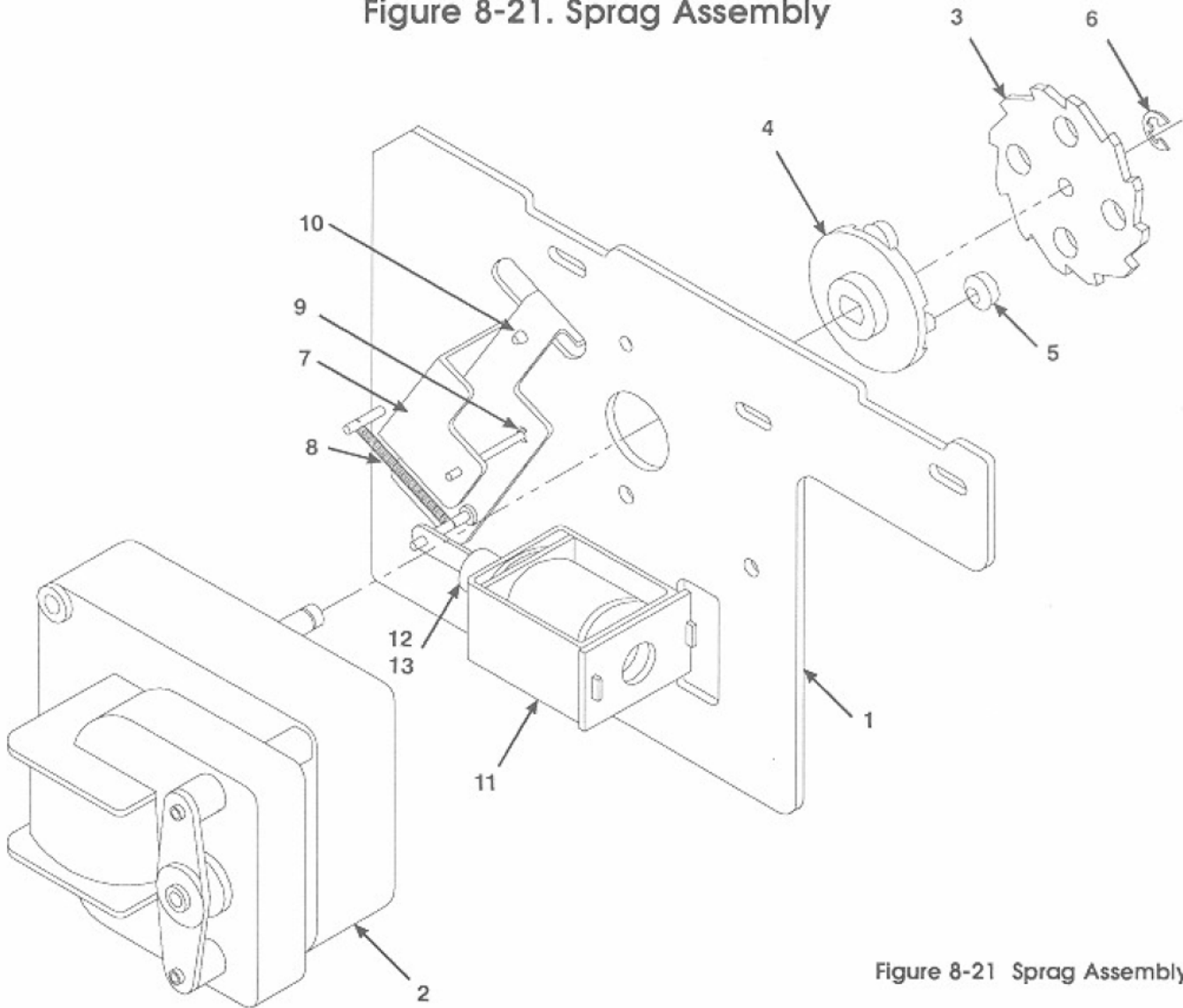

Figure 8-21 Sprag Assembly

Ref.	Part No.	Description	Qty
	40721901	Sprag Assembly (see figure 8-20, sheet 1, item 8)	Ref.
1	30793901	• Sprag Plate Assembly	1
2	40722701	• • Magazine Motor	1
3	40722301	• • Sprag Wheel	1
4	30793301	• • Sprag Wheel Hub	1
5	21816103	• Stem Bushing (Rubber)	4
6	70143003	• Retaining Ring	1
7	21816001	• Sprag Lever Assembly	1
8	21256201	• Tension Spring	1
9	70143005	• Retaining Ring	1
10	25155901	• Split Stem Bumper	2
11	21150510	• Solenoid Assembly	1
12	21085701	• Plunger Assembly	1
13	21084902	• Plunger Stop	1

Figure 8-22. Cam Switch and Motor Assembly

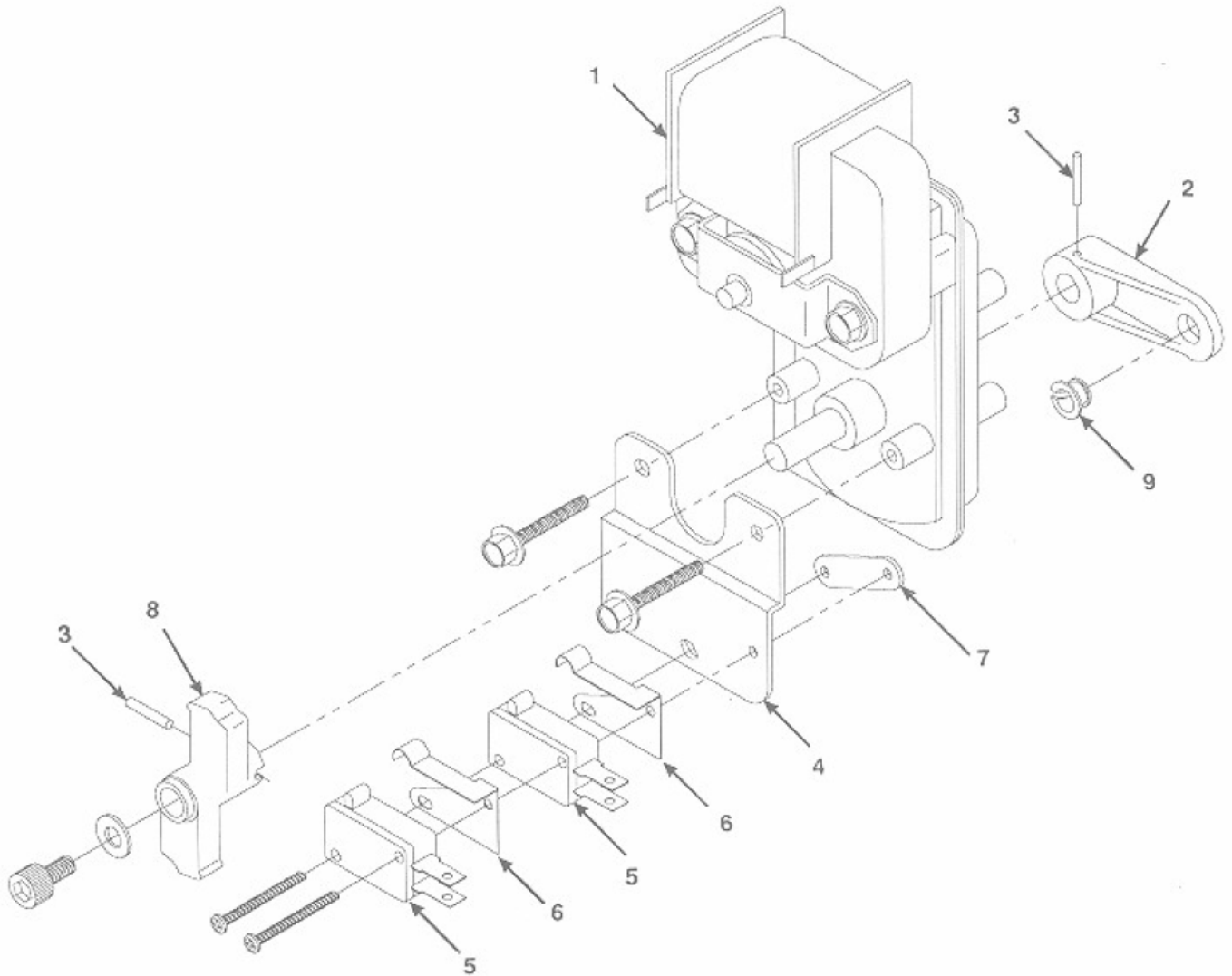

Figure 8-22. Cam Switch and Motor Assembly

Ref.	Part No.	Description	Qty
	40720802	Cam Switch and Motor Assembly (see figure 8-20, sheet 1, item 10)	Ref.
1	40720901	• Cam Motor	1
2	21810401	• Trunnion Crank	1
3	70113116	• Roll Pin	2
4	30790901	• Switch Plate	1
5	21073101	• Switch	2
6	21082901	• Switch Actuator	2
7	21083001	• Twin Nut	1
8	30793402	• Switch Cam	1
9	70146004	• Bearing	1

Table 8-1. Accessory Equipment

Part No.	Description	Function
26704401	Phono paging system With tabletop microphone	Paging system not affected by A.V.C. All plug-in unit, complete with microphone and 50 foot microphone cable.
26704402	Phonograph Paging System With hand-held microphone	Paging system not affected by A.V.C. All plug-in unit, complete with microphone and 50 foot microphone cable.
26694703	Amplifier Accessory Kit (Note: This kit will work with all 607925XX and 610237XX preamplifiers)	Provides access to auxiliary inputs and outputs of the preamplifier. Inputs will accept signals from most background music sources, such as tape players and AM/FM radios. Outputs are available to drive slave amplifiers before or after volume control.
21639701	Background Music Kit	Allows the phonograph to play Autoplay and customer selected music at different levels. Music can be played at different volumes in two different rooms or music can be switched to different rooms during either Autoplay or customer selections.
30632201	Remote volume and cancel control	The remote stereo volume control includes a cancel button. This kit does not include cable. A 3-conductor cable is required.
60898004	Remote volume power switch and cancel control	In addition to volume and cancel functions, the phonograph can be turned OFF and ON from a remote position. The CD currently playing is automatically canceled when the phonograph is turned OFF. The amplifier remains ON so that paging is possible. For domestic 120 volt phonographs only. Cable is not included. A four conductor cable is required.
30632209	Dual remote volume control	Controls volume of each channel separately. Does not include cable. A 4-conductor cable is required.
20819907	Remote volume and cancel control cable	This 3-conductor 50 foot cable connects a remote volume control to a phonograph.
20819908	Remote volume and cancel control cable	This 4-conductor 50 foot cable connects a remote volume control to a phonograph.
66505901	Service Kit	Includes central computer, digital display, power supply board, optical switch, power supply heat sink, blank titles, micro switches, peanut lamps, and fuses.
66505903	Service Kit	This kit includes: Mechanism controller and decoder assembly, CDM-4 CD player with mounting accessories.

Part No.	Description	Function
26711401	Amplifier Adapter Harness	Allows a 130 watt amplifier to be connected to a CD-100C as a replacement amplifier (the total amplifier output will be limited to 130 watts in this configuration).
26699503	Security Bar Kit	Heavy steel bar locks in place over cash box door. A padlock is required (not supplied by Rowe).
26713201	Prestige Silver Touch Up Paint	
21945601	Printer Interface Kit	Allows you to connect a serial RS-232 printer to a CD-100C. The printer must be at least a 40-column printer (Citizen Model iDP-560 RSL is recommended).
40846001	Keyboard Cover	Provides a flexible shield that protects the selection keyboard (POPULAR, RESET, 0-9, <, >) from water and other fluid spills.
21957501	LaserStar IR (Infra-Red) Remote Control Kit	Wireless remote control of: volume, cancel, selections, and pause. Volume of each channel can be controlled separately, or both channels can be controlled at once.

Parts Included In The Handy Case

(Refer to Figure 8-5)

21730516	• Accessories Bag Assembly	1
21827201	•• Bag - Zip Lock	1
70097501	••• Contact - Univ Conn (Pin)	6
70097502	••• Contact - Univ Conn (Socket)	6
70075601	••• Contact - Post	10
70091012	••• Terminal Lug - Spade	10
70072002	••• Fuse Cartridge (8 amp.)	2
70072106	••• Fuse Cartridge (5 amp.)	2
26676802	••• Quality Card - Phonograph	1
21822620	•• Manual - Service (CD-100C, Volume 1)	1
21822621	•• Manual - Service (CD-100C, Volume 2)	1
21888607	•• Programming Reference Guide	1
21957002	•• Routine Service Guide	1
30931304	•• Alternate Price Card	1
61031402	•• Universal Price Sheet	1
30935903	•• Blank Title Strip With Numbers	15
30940601	•• Title Page Filler	8
30935904	•• Blank Title Strip (Without Numbers)	15
21969501	•• Errors Guide	1

This page intentionally left blank.