

Section 1: Installation & System Description

INTRODUCTION

The CD-100A phonograph is an updated version of the very successful CD-100 Phonograph. The CD-100A plays compact discs exclusively. The outer appearance of the CD-100A is similar to the CD-100, and many of the functional modules are very similar to previous 45 RPM record models. The reliable record mechanism has been modified to hold up to 100 compact discs. These discs are played through a 250 watt stereo sound system.

The major difference between the CD-100 and the CD-100A is that the CD-100A has additional programmable features.

Before you begin to unpack and use this phonograph, you need to pay special attention to the following:

Read This Carefully Before You Put Your New CD-100A In Service

- **Mechanism**—Completely unpack the mechanism before you plug the 2-wire Yellow and White/Black cable into P10 on the CD mechanism.
- **Title Pages**—If you wish to turn the title pages manually, use the handwheel on the back of the title rack.
- **CD Player**—Read the CD player unpacking procedure and the static caution that accompanies the procedure.
- **Title Rack**—Before you close the top door, make sure that you have returned the title rack and hinged title rack support bracket to their normal positions .

FEATURES

The CD-100A utilizes many of the standard Rowe CD phonograph service features and contains many new features. The major CD-100A features are:

General Features:

- Sturdy construction and reliable design
- Conveniently located customer, operator, and service controls
- New attention getting animation display and expanded Autoplay options
- Electrically operated title pages
- Entire albums can be selected
- A 250 watt amplifier with dual 7-band graphic equalizer
- Increased AVC range keeps CD volume constant over a wider range
- 100 disc capacity
- As selected (FIFO) playback or random playback
- 500 Bill capacity
- Attract mode to merchandise music or advertising
- Many new phonograph programming options
- A total of 25 selections may be "locked out"
- A total of 10 selections may be "priorities"
- A total of 25 selections may be "premium"
- A real-time clock allows Autoplay, lockouts, and free play to be scheduled by time and day
- Accessory available to play background music and/or autoplay at different volume levels

Service Features:

- All servicing can be done from the front of the phonograph
- Modular component construction for easy removal and replacement
- Alpha/Numeric display gives you more comprehensive readouts
- Complete cash and play audit information
- Three levels of security access provide limited access to route operators if desired
- Disc condition logging feature to help find skipping selections and unplayable discs.
- Machine errors and disc conditions are logged by time and date
- Choice of 3 CD initialization procedures
- Optional RS-232 Interface allows you to print audit data, Memorec data, pricing options, disc conditions, and error history.

UNPACKING INSTRUCTIONS

This section contains information for unpacking the CD-100A and installing it on location. The phonograph is shipped with all major components in place. Save all tie-down hardware in case the CD-100A must be moved to another location.

Exterior

1. Remove the shipping carton with care: Do not use shipping hooks or sharp tools that could damage the phonograph cabinet.
2. Remove the plastic bag that covers the phonograph.
3. Carefully inspect the interior and exterior of the phonograph to ensure that no damage occurred during transit.

If damage is detected, the carrier who delivered the phonograph should be contacted immediately to examine it. Regardless of the exterior condition of the shipping cartons, the carrier should be called and notified of damage. Do not destroy the packing material or boxes until the carrier's agent has examined them. Damage claims are your responsibility. Do not return shipping damaged merchandise until after your claim has been established. Once your claim has been established, merchandise may be returned to your Rowe distributor for repair. The invoice amount for repair charges can then be collected from the carrier.

Doors

1. Locate the red bag on the top door. Remove the door key from the bag and unlock the top door. Turn the key to the right and press down on the top door as you turn the key.



WARNING:

Step back as you release the top door so that you do not hit your chin with the top door.

2. Open the front door by pressing down on both front door latches (*see figure 1-1*).

Shipping Bolts, Clips, And Tape

TITLE RACK

1. Remove the shipping tape from both ends of the lower title rack assembly support bar.
2. Remove the shipping tape from the front of the title rack pages.



CAUTION:

Do not attempt to turn the CD title pages by hand. Use the handwheel on the back of the title rack (see figure 1-2).

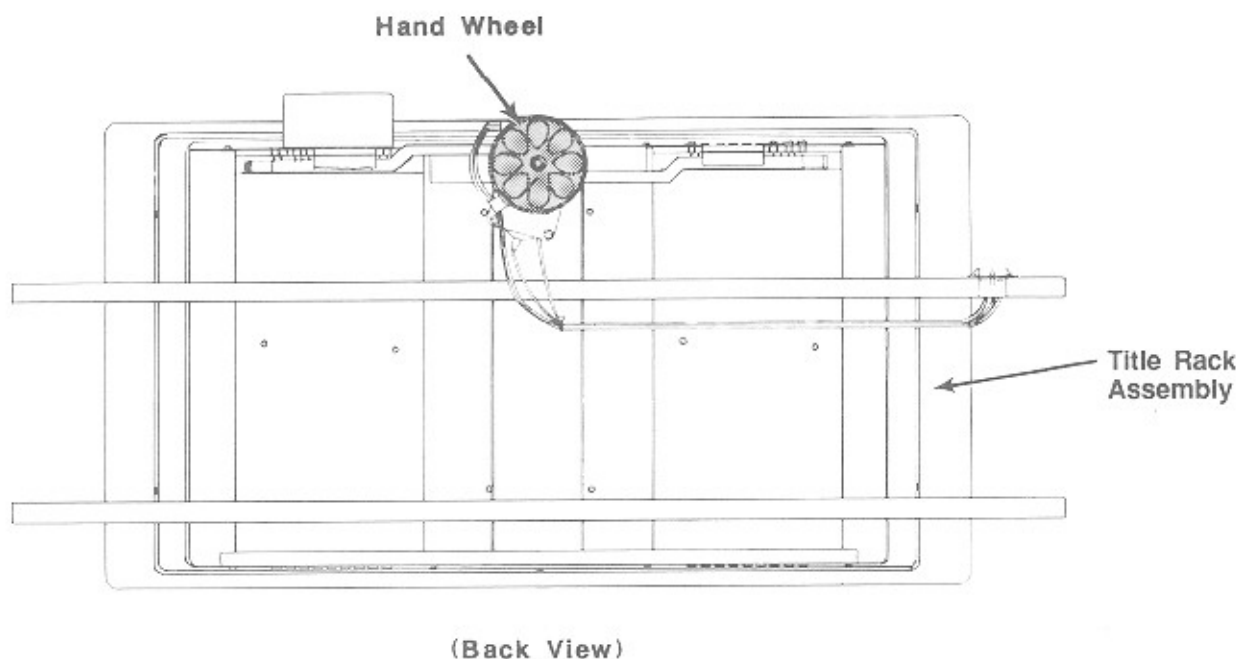

Figure 1-2. Title Rack Hand Wheel

Save all shipping hardware that you remove in the following six steps.

Mechanism

CD UNPACKING



CAUTION:

The CD mechanism is extremely sensitive to static discharges. The photo diodes and the laser are more sensitive to discharges than MOS IC's. Careless handling may immediately destroy components within the player or cause undetectable damage that will lead to failure after several weeks or even months of use. Before you touch the player, discharge your hands and tools by touching a grounded metal part of the phonograph, such as the amplifier or power supply chassis. If you need to remove the CD player for servicing, place the CD player into the anti-static bag (shipped with the phonograph for this purpose) immediately after you remove it from the phonograph.

1. Remove the CD changer mechanism shipping bolt from the back of the phonograph cabinet (see *figure 1-3*).

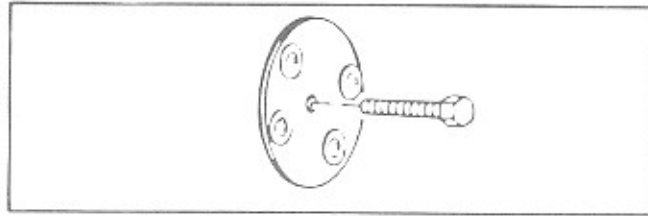

Figure 1-3. Shipping Bolt Removal

2. Remove the shipping tape from the front ends of the mechanism tie-down levers on the side of the mechanism frame (see to *figure 1-4*).
3. Push the end of the lever down slightly, rotate the lever away from the frame until the latch tab clears the hole in the frame, rotate the lever up until the mechanism is free, and remove the levers.

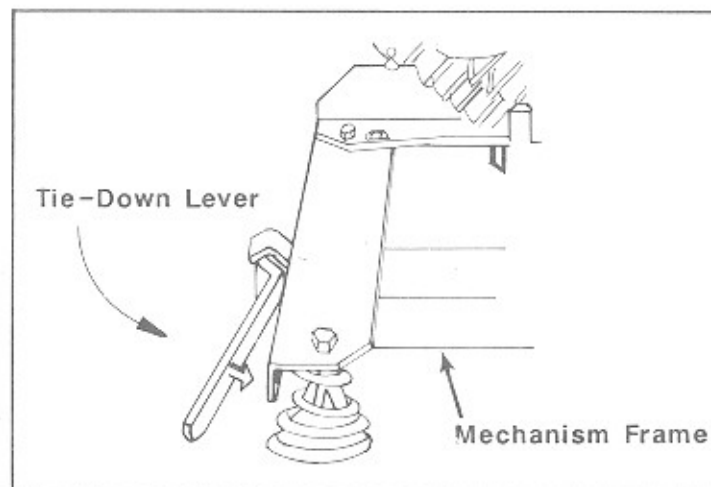

Figure 1-4. CD Changer Tie-Down Levers

Do not proceed with unpacking until you read and understand the following caution:



CAUTION:

The CD mechanism is extremely sensitive to static discharges. The photo diodes and the laser are more sensitive to discharges than MOS IC's. Careless handling may immediately destroy components within the player or cause undetectable damage that will lead to failure after several weeks or even months of use. Before you touch the player, discharge your hands and tools by touching a grounded metal part of the phonograph, such as the amplifier or power supply chassis. If you need to remove the CD player for servicing, place the CD player into the anti-static bag (shipped with the phonograph for this purpose) immediately after you remove it from the phonograph.

4. Remove the rubber band on the hold-down plate.
5. Remove the rubber band, wire hook, and warning tag that hold the sprag lever out of the sprag wheel.
6. Remove all tape from the magazine belt and magazine pulley.
7. Plug the 2-wire, Yellow and White/Black mechanism cable into P10 of the CD mechanism control module.
8. Check to see that the title page assembly is plugged in.

VISUAL INSPECTION

Check to be sure that all electrical plugs are completely seated into their receptacles.

PHONOGRAPH LEVELING

To ensure proper coin acceptor operation (if used), level the phonograph cabinet from left-to-right and front-to-back by inserting spacers under the caster wheels.

HANDY CASE

The Handy Case is a blue plastic envelope located on the left hand side of the phonograph. The Handy Case contains a variety of items, including the phonograph service manual and parts catalog, spare parts, and fuses. Keep the Handy Case inside the phonograph so that the service manual and parts will be readily available when needed.

WARRANTY REGISTRATION CARD

A postage-paid Warranty Registration Card is included with the phonograph. This card should be filled out and returned to Rowe.

MAJOR COMPONENTS OF THE CD-100A

Figure 1-1 shows the major CD-100A Phonograph components. Take a minute to familiarize yourself with these components.

Table 8-1 lists the accessories that you may have in addition to the standard phonograph.

CD Selection System

CD selections are made by entering the four digit selection number on the selector keyboard (keyboard) (See figure 1-5).



Figure 1-5. Keyboard

Keyboard

The keyboard consists of 14 keys, ten digit keys (0-9), and four special keys. The two PAGE CHANGE keys move the title pages electrically. The RESET button allows the customer to re-enter his selection, if he has changed his mind or made a mistake. The POPULAR key selects the selection that customers have selected the most number of times. Pressing the POPULAR key a second time will select the second most popular selection. Pressing the POPULAR key a third time will select the third most popular selection and so on.



NOTE:

On a new phonograph, a phonograph that has had its CCC replaced, or a phonograph that has had the POPULARITY cleared, the POPULAR key will not select any disc number until at least one normal selection has been made.

Central Control Computer

The central control computer (CCC) keeps track of all of the phonograph's activities and determines what the various components are to do next. The CCC regulates the following functions:

- Calculating credit and making selections
- Keeping track of selections not yet played
- Calculating the most popular selection list
- Remembering the operator's programmed values

Memorec

Memorec is the part of the CCC that remembers the:

- Number of times each selection was played
- The total amount of money deposited in the phonograph

Autoplay

When no selections have been made for a predetermined time, the Autoplay feature will play selections from a programmed list or make random selections. The choice of which selections are chosen, the selection sequence, and the selection interval can be programmed by the owner or service person.

PRINCIPLES OF OPERATION

Audio System

The audio system consists of the electronic components that transform the recorded sound into music. The major components of the audio system are the:

- CD player
- Stereo amplifier
- Output transformers
- Speaker system

CD PLAYER

This sub assembly translates digital pulses from the CD into a left and right channel audio signals.

STEREO AMPLIFIER

The amplifier assembly (*see figure 1-6*) contains two major sections, the preamplifier (preamp) and the power amplifier (amp).

Preamp

The preamp increases the signal from the CD player, corrects for varying recording levels (automatic volume control or AVC), allows the volume to be adjusted manually, and modifies the CD tone (Tone changes are made through a 7-band graphic equalizer).

Power Amplifier

The power amplifier converts the preamp signal to a signal that can be used by the phonograph speakers.

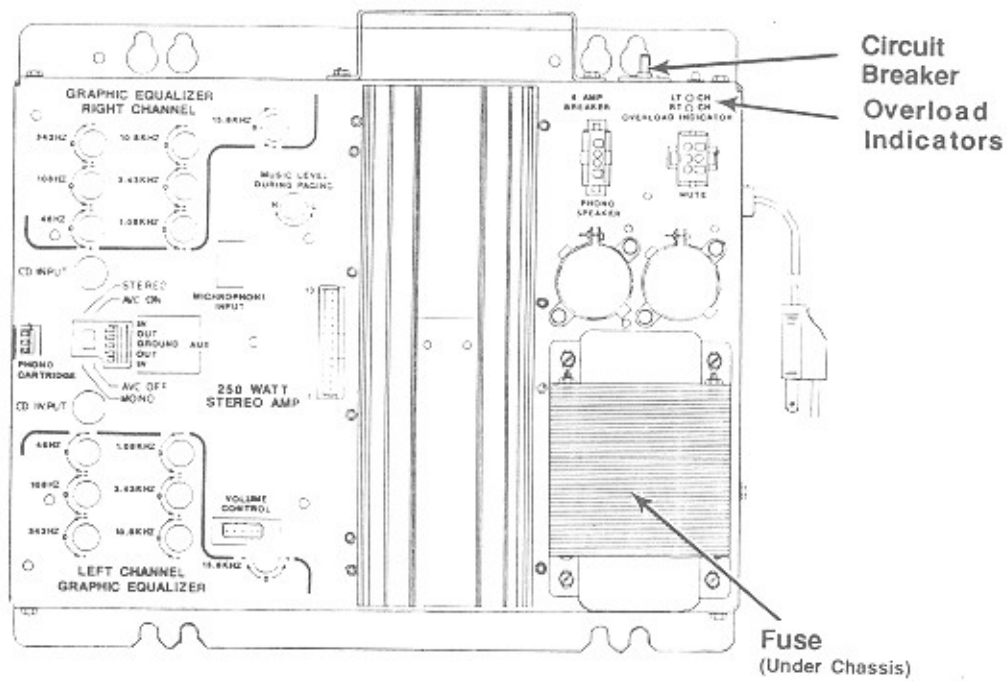

Figure 1-6. 250 Watt Stereo Amplifier Components

TWO-WIRE VOLUME CONTROL

A Rowe innovation, the two-wire volume control simplifies complex installations and reduces cost. A special preamplifier design permits volume control wiring using any unshielded two-wire cable.

OUTPUT TRANSFORMERS

The output transformers (figure 1-7) "step up" the power amplifier's output voltage for 70-volt extension speakers. The output transformers, also, provide connections (taps) for selecting different power levels and impedances (loads) for the speakers.

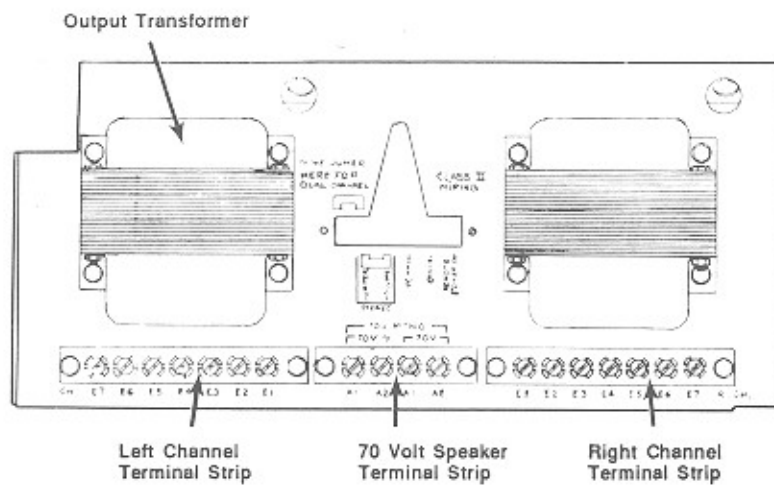

Figure 1-7. Output Transformer Package Components

THE SPEAKER SYSTEM

The speaker system consists of two specially designed speaker channels. Each channel consists of one 10-inch woofer, one mid/high range speaker, a tweeter, and a crossover network.

CD Changer Mechanism

The CD changer mechanism, also referred to as the "mechanism" or "mech", is located in the center of the cabinet's interior. It is the primary mechanical component of the phonograph. The mechanism holds 100 CD's and plays selections on command from the selection system (refer to figure 1-8 for the location of each of the major magazine components).

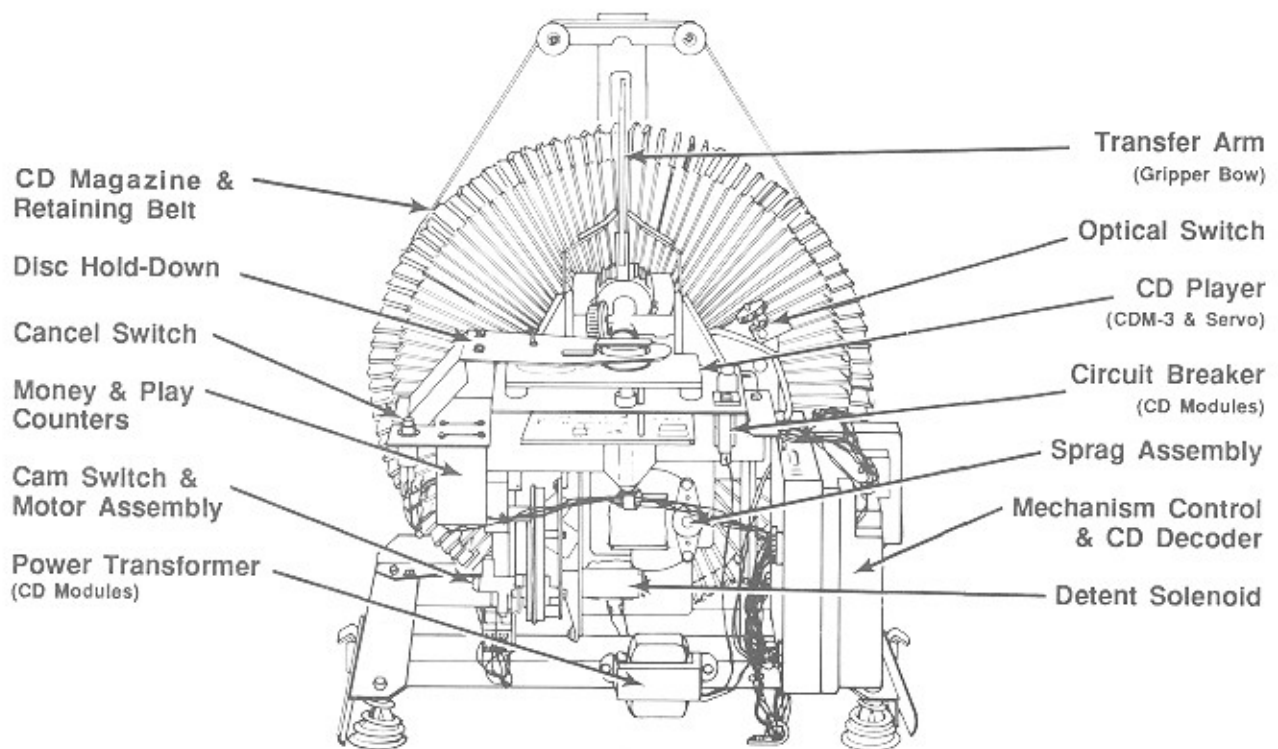

Figure 1-8. CD Changer Mechanism

MAGAZINE

The CD magazine stores 100 CD's in a circular cage.

PLAY COUNTER

The play counter accumulates the total number of plays on the mechanism.

MONEY COUNTER

The money counter registers the total money deposited in the phonograph.

OPTICAL SWITCH

The optical switch senses the CD magazine position so that the CCC can determine which CD is in gripping position.

CAM SWITCH AND MOTOR ASSEMBLY

The cam switch and motor assembly (see figure 1-9) consists of the transfer motor, cam, and two cam switches.

SPRAG ASSEMBLY

This assembly locks the CD magazine in position.

CD MODULES

The CD player and the CD decoder play CD's after they are positioned on the turntable by the disk transfer arm.

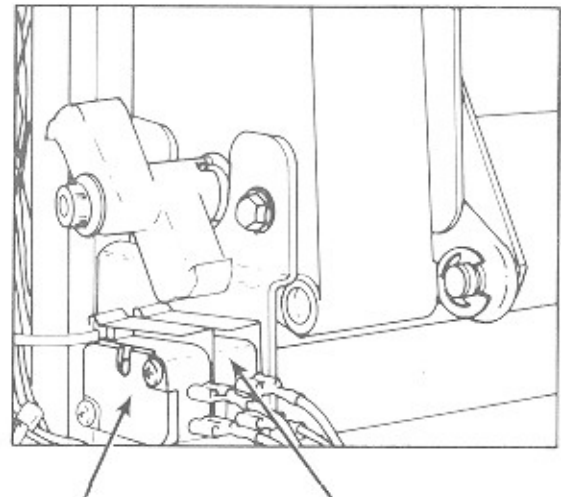

Outer Cam Switch
Actuated in CD Playing
Position

Inner Cam Switch
Actuated in Standby
Position

Figure 1-9. Cam Switch & Motor Assembly

Mechanism Control Unit

This solid state switching unit controls the scan and transfer.

Main Power Supply

The main power supply (see figure 1-10), located inside the amplifier compartment, distributes unregulated +28 VDC, 28 VAC, and regulated +8 VDC to the phonograph. The 120 VAC line voltage to the main power supply is controlled by the power switch on the rear of the phonograph cabinet.



CAUTION:

The 120 VAC AMPLIFIER OUTLET on the main power supply does not shut off by turning the POWER ON/OFF switch on the back of the phonograph OFF.

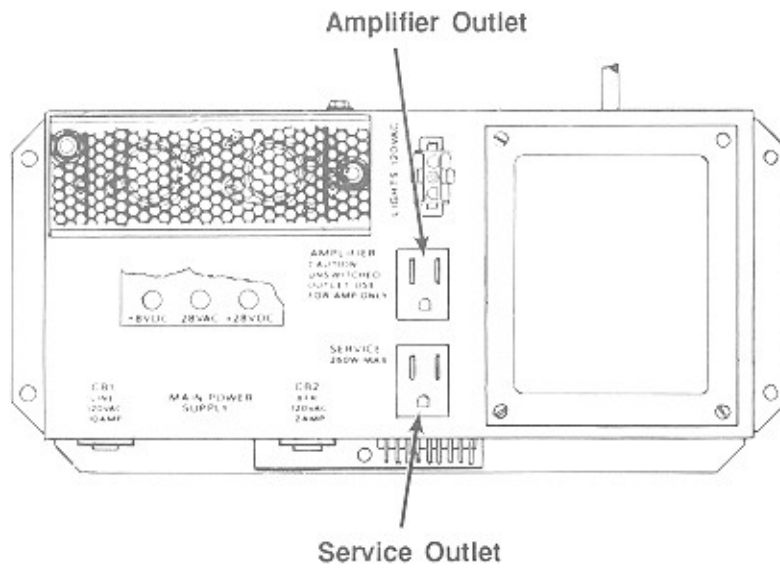

Figure 1-10. Main Power Supply