

## Section 6: Mechanical Adjustments

### LUBRICATION

Your phonograph requires no lubrication.

### UNSCHEDULED MAINTENANCE

This section contains adjustments, removal, and replacement procedures that are to be followed whenever a malfunction has occurred.

### MECHANISM MAINTENANCE AND ADJUSTMENTS



#### CAUTION:

The CD mechanism is extremely sensitive to static discharges. The photo diodes and the laser are more sensitive to discharges than MOS IC's. Careless handling may immediately destroy components within the player or cause undetectable damage that will lead to failure after several weeks or even months of use. Before you touch the player, discharge your hands and tools by touching a grounded metal part of the phonograph, such as the amplifier or power supply chassis. If you need to remove the CD player for servicing, place the CD player into the anti-static bag (shipped with the phonograph for this purpose) immediately after you remove it from the phonograph.

### CD Player Mechanism

The only maintenance required on the CD player is an occasional cleaning of the lens. If you need to clean the CD player lens, be sure to follow the procedure described in *Table 3-3, Laser Lens Cleaning*.

### CD Player Maintenance

The CD player does not contain any field adjustments or field replaceable parts. Individual parts and components are not available for distributor or field repairs. All CD players that require repair must be sent to Rowe for service.

## Removing The CD Player And Mechanism Control Unit

If you have followed the troubleshooting procedure in *Section 5*, and you have found that the CD player and the mechanism control unit needs to be removed for factory service, follow this procedure:

1. Turn the POWER switch (on the back of the phonograph) OFF, or place the POWER switch (on the left side of the phonograph) in the OFF position.
2. Remove all connectors from the mechanism control unit, loosen the two top screws (*figure 6-1, ref. A*), and remove the mechanism control unit.
3. Read the following Caution before you remove the CD player:



**CAUTION:**

The CD mechanism is extremely sensitive to static discharges. The photo diodes and the laser are more sensitive to discharges than MOS IC's. Careless handling may immediately destroy components within the player or cause undetectable damage that will lead to failure after several weeks or even months of use. Before you touch the player, discharge your hands and tools by touching a grounded metal part of the phonograph, such as the amplifier or power supply chassis. If you need to remove the CD player for servicing, place the CD player into the anti-static bag (shipped with the phonograph for this purpose) immediately after you remove it from the phonograph.

Loosen the two front mounting screws (These screws remain part of the phonograph. *See figure 6-1, ref. B* on the underside of the CD player mounting plate.

4. Slide the player approximately 1 inch toward the front of the phonograph and lift the front of the CD player up slightly and so that you can unplug the two connectors on the back side of the CD player. Remove the connectors by depressing the latches on each connector and separating the connectors from their sockets.
5. Lift the CD player up and out of its mounting bracket.
6. Remove the two rear mounting screws and grommets from the player assembly and install them on the replacement CD player.
7. Immediately place the CD player into the anti-static bag (supplied with the phonograph) and return the CD player to your distributor.

To replace the CD player, reverse the previous steps. *Refer to figure 6-2* for the mechanism control connecting diagram.

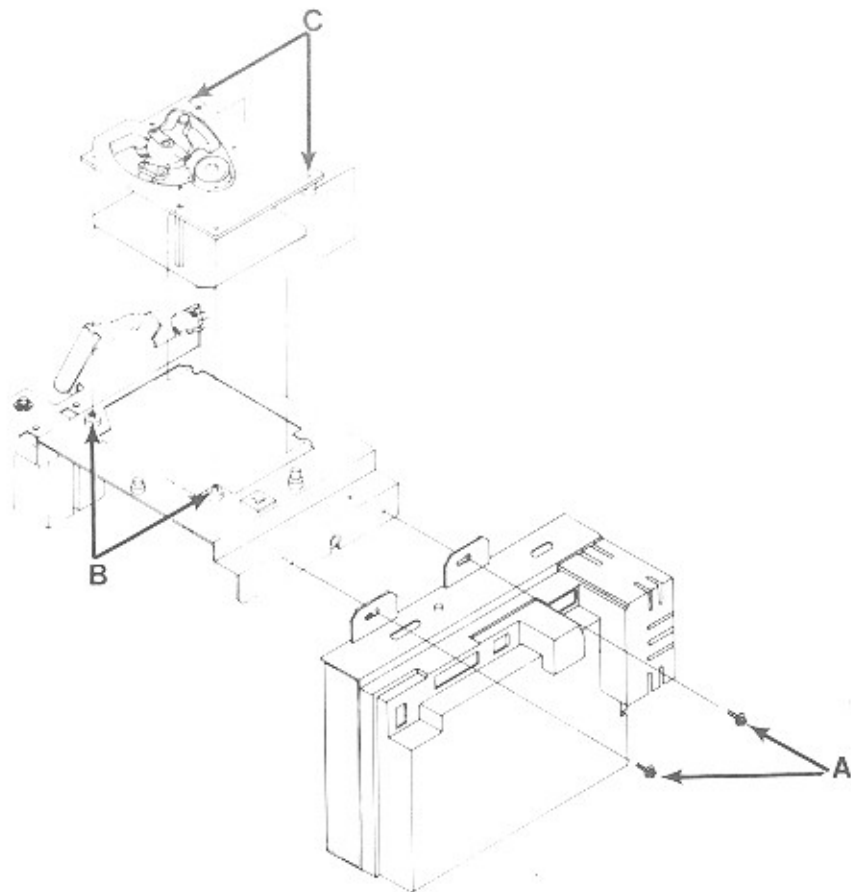

Figure 6-1. Removing the CD Player

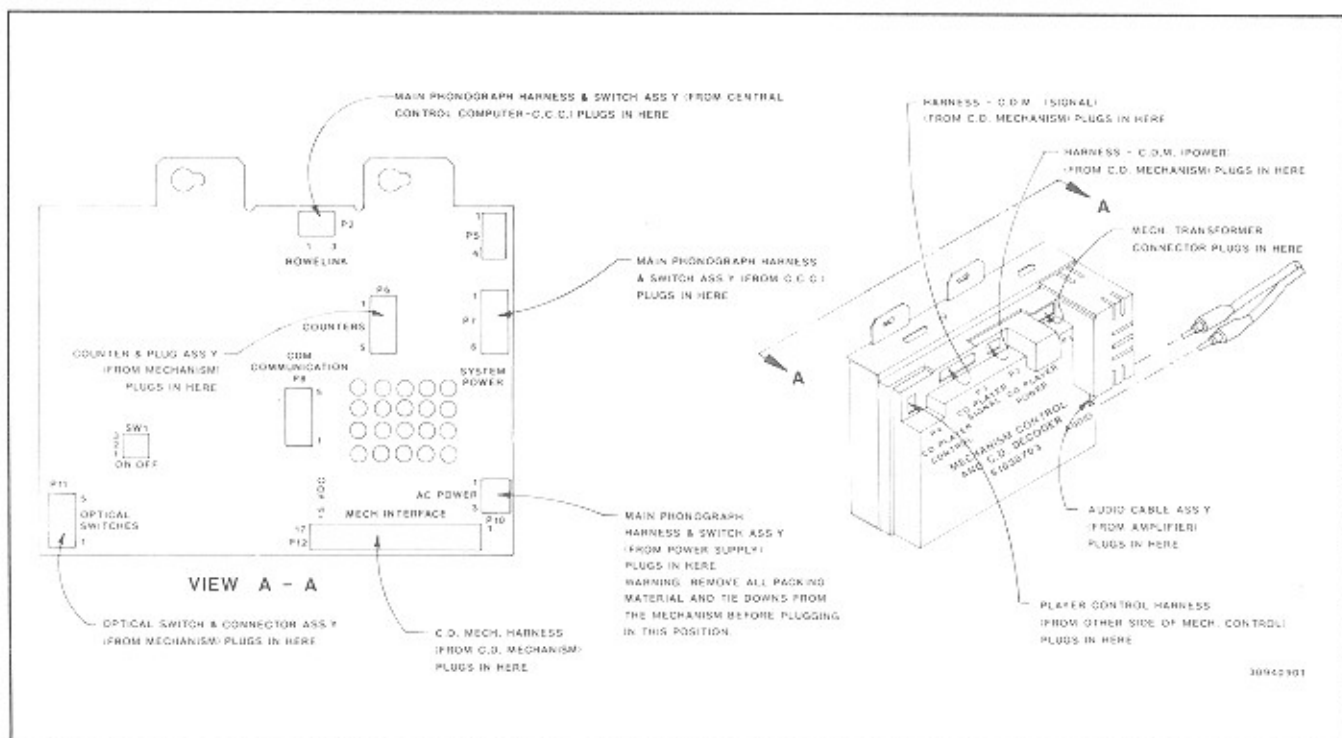

Figure 6-2. Mechanism Connecting Diagram

## Hold Down Assembly And Hold Down Plate Height

### SERVICE CHECK

With the gripper bow in the play position and the disc on the turntable (the outer cam switch is actuated), the aluminum hold down plate (figure 6-3) should be  $3/32$  to  $5/32$  inch ( $1/8 \pm 1/32$ ) under the flange of the magnetic hold down hub.

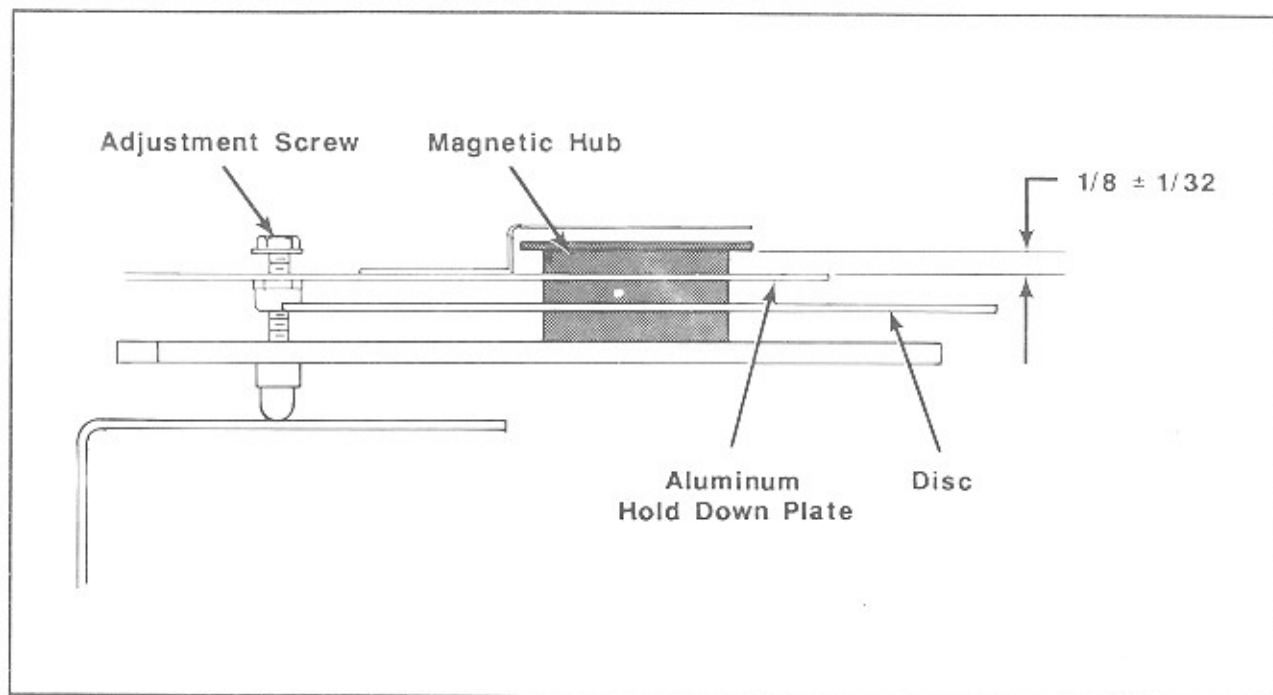

Figure 6-3. Hold Down Plate

### ADJUSTMENT

If the hold down plate height is not correct, turn the adjustment screw (figure 6-3) until the  $3/32$  to  $5/32$  ( $1/8 \pm 1/32$ ) height is attained.

### HOLD DOWN LIFTING CAM ADJUSTMENT

Refer to figure 6-4 as you make this adjustment.

1. With the gripper bow in the SCAN position over the magazine (transfer motor crank in the maximum down position), loosen one Allen-head screw in the collar.
2. Use a  $5/32$  Allen Wrench in the end of the transfer motor shaft to turn the

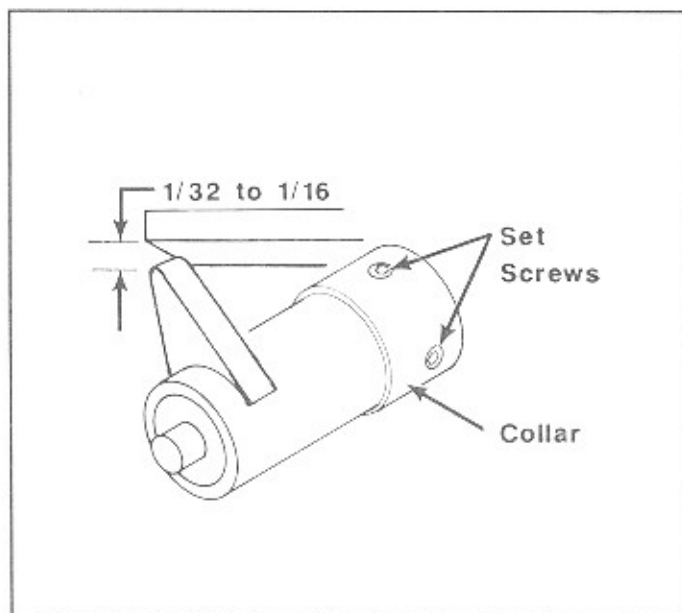

Figure 6-4. Hold Down Lifting Cam Adjustment

motor shaft clock-wise until the gripper bow is in the playing position (transfer motor crank in the up position).

4. Loosen the other Allen-head set screw in the collar.
5. Position the cam to clear the lifting surface by 1/32 to 1/16 inch.
6. Tighten the Allen-head set screws.

### HOLD DOWN PLATE CENTERING

Refer to figure 6-5 for this adjustment.

1. With the gripper bow in the PLAY position and the disc on the turntable, loosen the two centering adjustment screws slightly.
2. Look straight down on the turntable hub and shift the hold down plate until the scribed "witness" line appears to be centered around the magnetic hold down hub. Rotate the disc and turntable hub (notice that the hold down hub will not run perfectly true).
3. Shift the hold down plate until it appears to be in the best compromise position with the slightly off-center position of the hold down hub. Look for equal clearance as it rotates.
4. Tighten the two centering adjustment screws and recheck the previous adjustments.

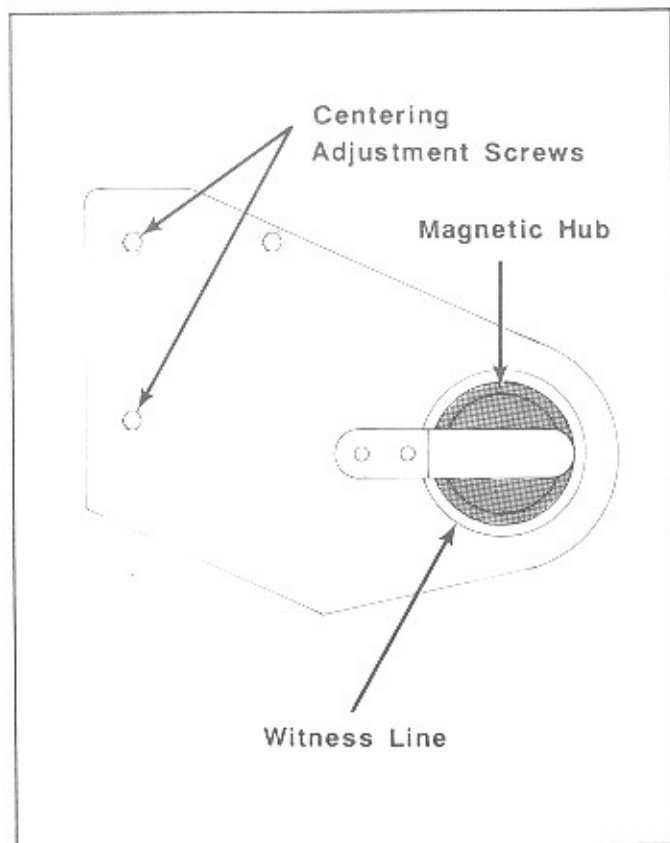

Figure 6-5. Hold Down Centering

### Optical Switch Adjustment

1. Push in the detent plunger, so that the magazine can be rotated to Position 99. Engage the detent plunger.
2. Loosen the optical switch bracket mounting screw, turn the adjustment knob counter clockwise to top of its travel, and move the bracket down to the bottom of its travel (refer to figure 6-6). Snug the optical switch mounting screw, so that the bracket can move with resistance.
3. With the detent plunger engaged, rotate the magazine counter-clockwise to remove gear backlash and maintain pressure for steps 4 and 5.
4. Turn the adjustment knob clockwise until both the INDEX and HOME LED's are ON.
5. Continue turning the adjustment knob clockwise until the INDEX LED goes OFF. The HOME LED must remain ON. Then turn the knob one full turn clockwise and tighten the mounting screw. The INDEX LED must be OFF and the HOME LED can be ON or OFF.

6. Push in the detent plunger and rotate the magazine to Position 06.
7. With the detent plunger engaged, rotate the magazine in both directions as far as you can by hand (taking up the gear backlash in both directions). The INDEX and HOME LED's will remain OFF when properly adjusted.
8. Push in the detent plunger and rotate the magazine to Positions 56, 07, and 57. Repeat step 7 at each position.

Adjusting  
Knob

Bracket  
Mounting  
Screw

Bracket

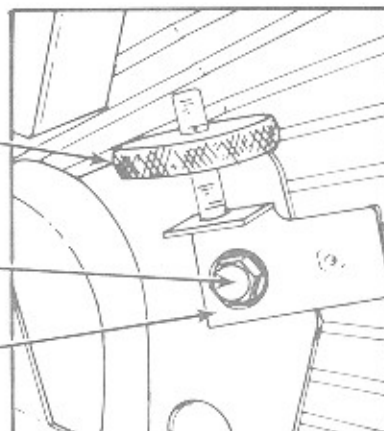

Figure 6-6. Optical Switch Adjustment

## Sprag Assembly

### ADJUSTMENTS

The following steps must be used to make sprag assembly adjustments.



## WARNING:

Turn the power OFF before servicing the sprag assembly.

1. Refer to figure 6-7. Depress solenoid plunger until the roll pin bottoms on the plunger stop (actuate by pressing on plunger).

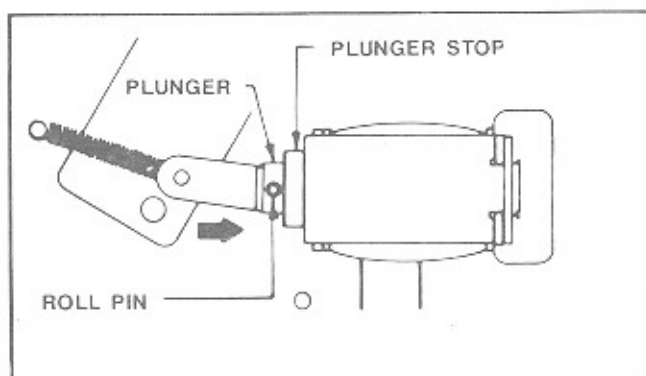

Figure 6-7. Sprag Assembly (Plunger)

2. Rotate the disc magazine and note the clearance between the sprag lever and the sprag wheel located on the backside of the sprag plate assembly.

The sprag lever must not touch the sprag wheel and the clearance must be .015 to .025 inches (see figure 6-8). It will be necessary to remove the sprag assembly if corrections are required.

### SPRAG ASSEMBLY REMOVAL

1. To remove sprag assembly, disconnect wires to the solenoid and motor, remove the three mounting screws and slide the assembly out of the right side of the mechanism (see figure 6-9).
2. Loosen the solenoid mounting screws and with the roll pin against the plunger, position the solenoid so that there is a .015 to .025-inch gap between the sprag lever and the highest point on the sprag wheel (see figure 6-10).
3. Tighten solenoid mounting screws.
4. Replace sprag assembly in mechanism with three mounting screws and replace the Black and White/Blue wires to the solenoid and the Yellow and Yellow/Black wires to the magazine motor.

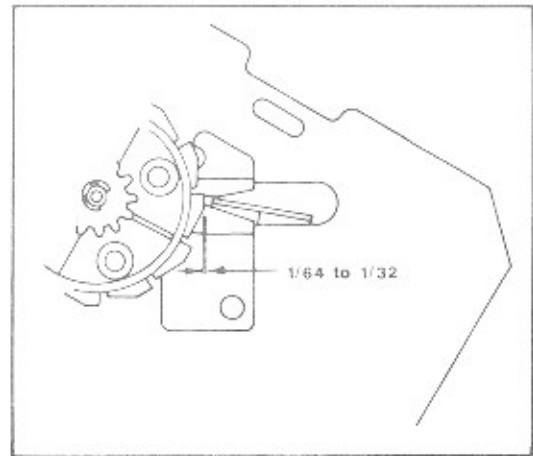

Figure 6-8. Sprag Wheel

Instructions for aligning the disc magazine are in this section under *Aligning Magazine Stopping Position With Transfer Arm*.

To readjust the optical switch, refer to *Optical Switch* in this section.

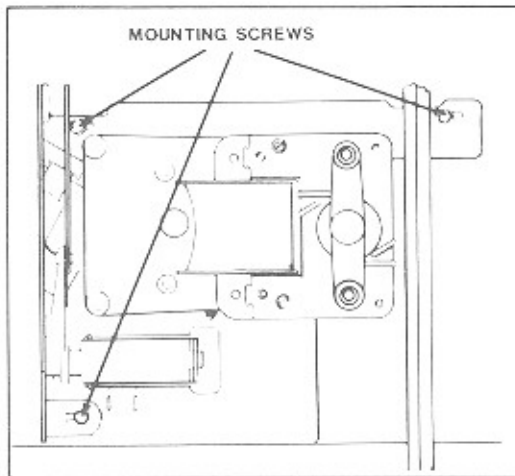

Figure 6-9. Sprag Assembly Removal

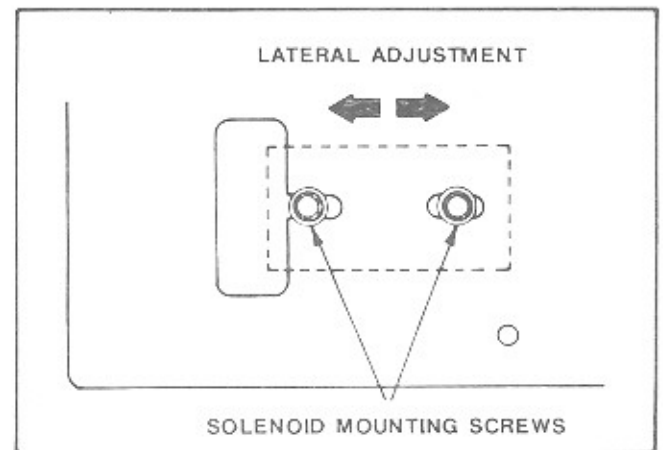

Figure 6-10. Lateral Adjustment

### Disc Magazine Transfer Arm And Support ADJUSTMENT

To eliminate magazine end play and center transfer arm support:

1. Loosen the set screws in rear magazine shaft collar. Push the collar on to magazine shaft to eliminate end play and tighten the screws.
2. Loosen the screw that holds the transfer arm support to the mechanism frame.
3. Adjust the transfer arm support so that the transfer arm is centered in the opening.
4. Tighten the mechanism frame to the transfer arm support screw.

## Cam Switch

### ADJUSTMENTS

If you need to remove the switch cam from the transfer motor, the following procedure must be followed to ensure that the cam is properly located and not 180 degrees out of position.

Locate the inner lobe so that it is pointing in the same direction as the crank. Turn cam so that neither cam lobe is on a switch before removing or installing the cam (see figure 6-11).

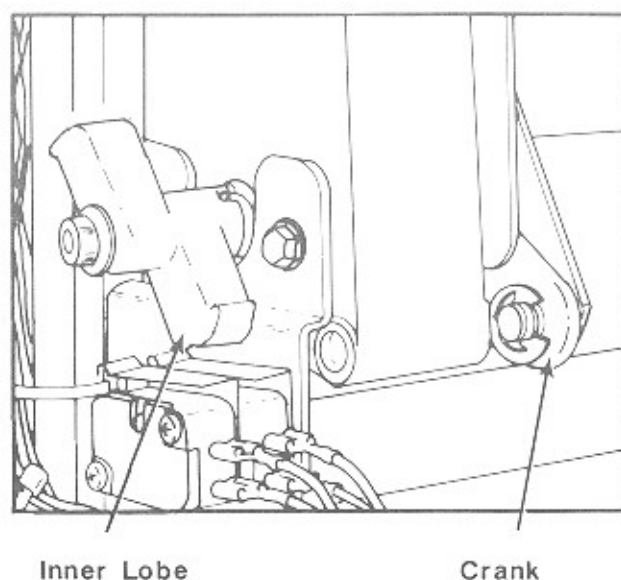

Figure 6-11. Cam Switch

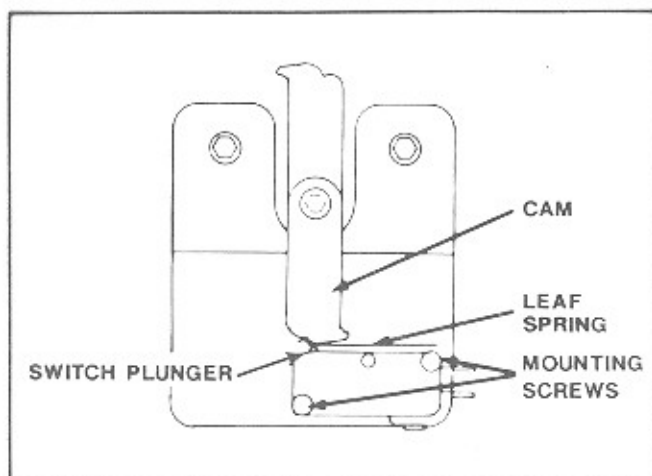

Figure 6-12. Cam Switch Adjustment

### CAM SWITCH CHECK AND ADJUSTMENT

1. Check that the plastic cam leaf spring is resting in the cam lobes and that the switch plunger just touches the bottom of the leaf spring as shown in figure 6-12.
2. To adjust the switches, loosen mounting screw under plunger end and move the switch housing as described in the previous step (see figure 6-12).
3. Tighten mounting screw and recheck operation.



## Magazine Belt Adjustment

1. Loosen the two adjustment screws shown in figure 6-13.
2. Raise the bracket to tighten the belt around the magazine.
3. Check that belt rides evenly in the center of the belt guides, all the way around the magazine.
4. Tighten the two adjustment screws.

### Aligning Magazine Stopping Position With The Transfer Arm

1. For this adjustment use a disc in good condition without warp or dish. Place this disc in any position in the disc magazine and rotate the magazine until this disc is in the top position. Allow the magazine sprag lever to engage and lock the magazine in this position.
2. Using a 5/32-inch Allen wrench in the end of transfer motor shaft, turn motor shaft clockwise until the gripper bow lifts the disc out of the magazine, and the outer shoe is approximately 3 inches from its rest position (see figure 6-14).

In this position, a center line from the inner shoe through the center of the outer shoe will pass through the back of the plastic disc guide on the magazine.

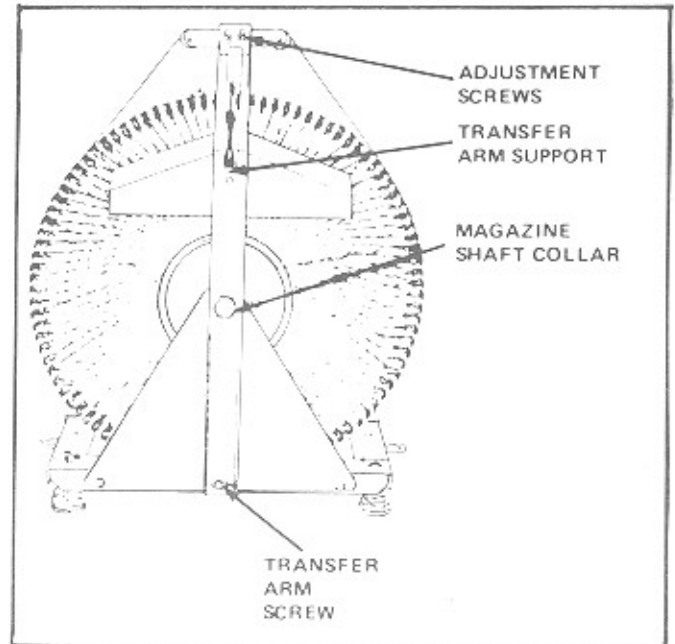

Figure 6-13. Magazine Belt Adjustment

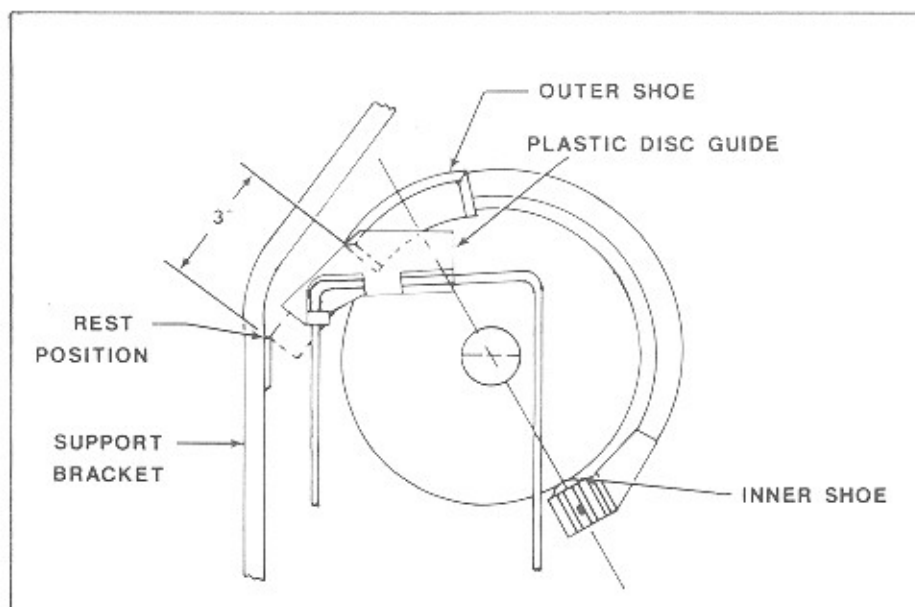

Figure 6-14. Magazine and Transfer Arm Position

3. With the disc and gripper bow in this lifted position, rock the magazine to the left and right and make sure the plastic magazine disc guides do not come in contact with the disc on either side.

If the guide makes contact with the disc on one side or magazine space does not center with the disc, the following adjustment to the magazine will be necessary:

4. Loosen three screws in the magazine motor mounting plate.
5. With sprag wheel locked, move the magazine until the disc is centered between belt guides (The adjustment screws will be approximately centered in the slots, see figure 6-15).
6. Tighten the three screws in the magazine motor mounting plate securely.

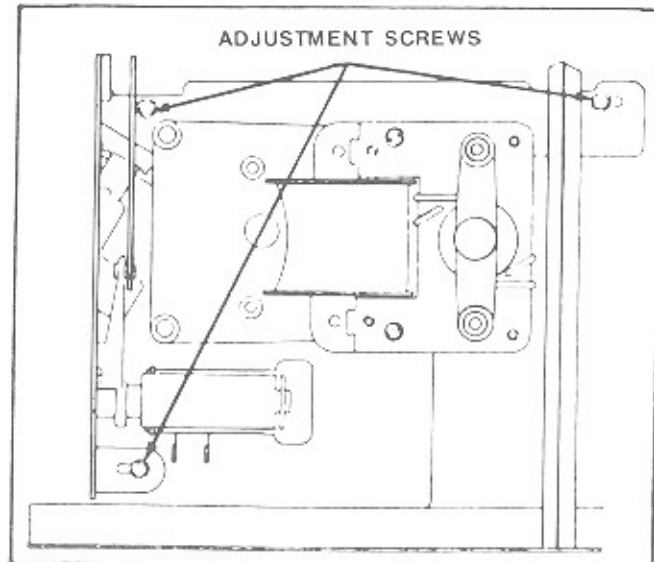

Figure 6-15. Magazine Adjustment

### Title Rack Switch Adjustment



#### CAUTION:

Do not attempt to turn the CD title pages by hand unless you use the handwheel on the back of the title rack (see figure 1-2).

Refer to figure 6-16 for illustration of the title rack adjustment.

1. Open the top door, unplug the title rack from the phonograph, and remove the title rack from the phonograph.
2. Loosen the switch mounting screw and the adjusting screw so that the switch can be rotated.
3. Use the handwheel to move the rack and pinion (and the title rack pages) so that the switch roller is directly over the top of one of the rack lobes. This will cause two of the title rack pages to point approximately straight out.
4. Insert a 0.040-inch feeler gauge between the switch body and the switch actuator arm.
5. Slowly rotate the switch downward until all clearance between the switch and the switch body is removed.

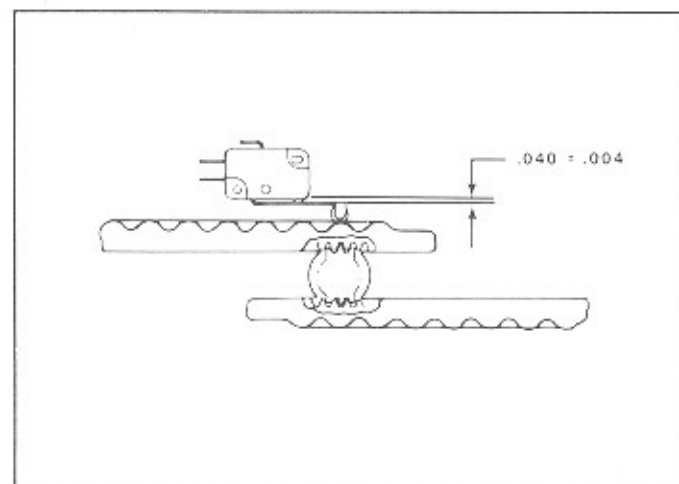

Figure 6-16. Title Rack Switch Adjustment

6. Tighten the switch mounting screw and the switch adjustment screw.
7. Turn the handwheel in both directions and verify that the switch clicks before the roller reaches the bottom of the rack (as it rolls "down hill") and before it reaches the top of the rack (as it rolls "up hill"). This distance should be approximately halfway between the peaks and the valleys of the lobes.
9. Re-install the title rack.
10. Perform *Title Page Re-Synchronizing* that follows this step.

### **Title Page Re-Synchronizing**

Title page re-synchronizing is necessary whenever power to the phonograph is interrupted or after the title pages have been changed with the handwheel.

1. Press either PAGE CHANGE button repeatedly until the pages no longer change (The pages may not advance as far as you expect them to. This is normal when the pages are being re-synchronized).
2. Press the other PAGE CHANGE button repeatedly until the pages no longer change.