

SECTION 3 - RECORD CHANGER MECHANISM MAINTENANCE

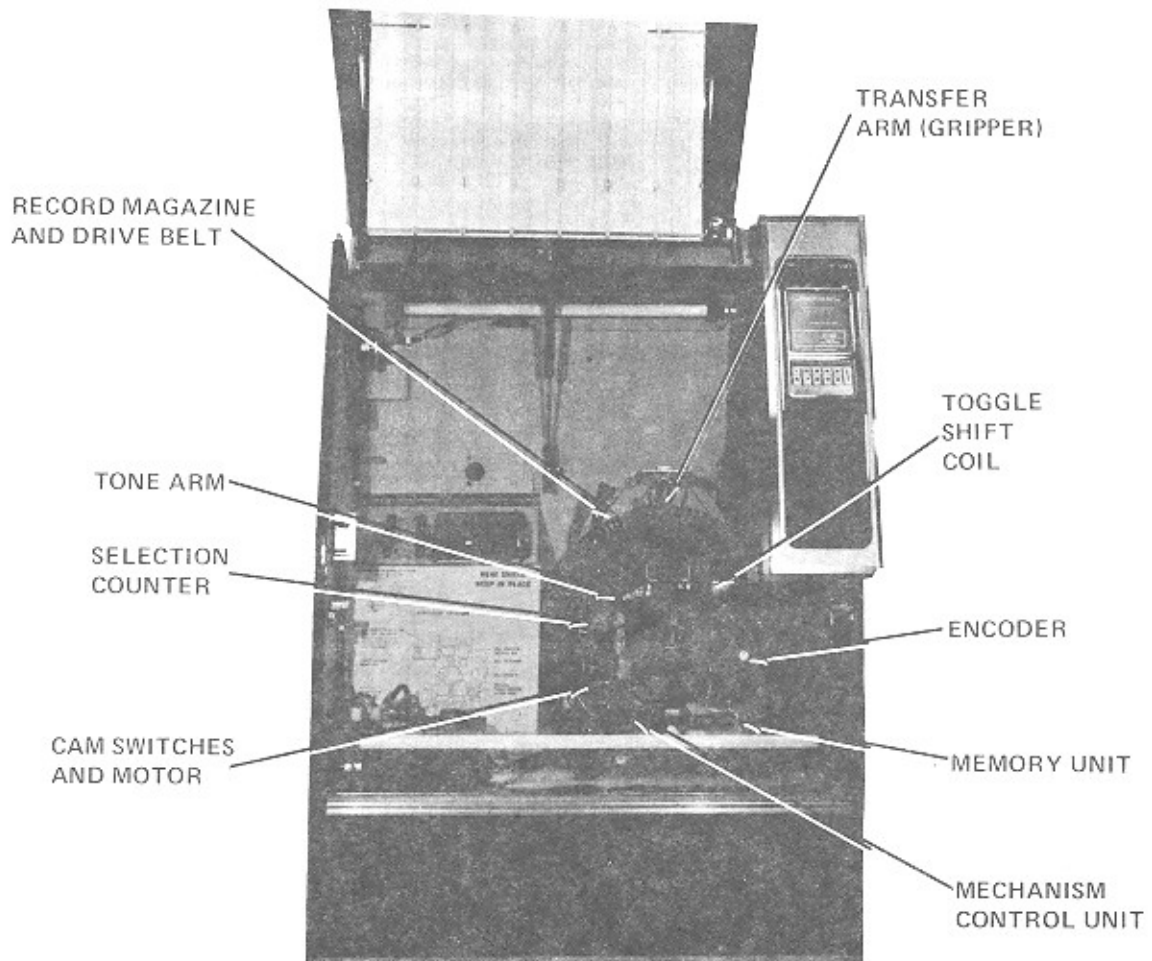

FIGURE 2-20. MAJOR COMPONENTS, RECORD CHANGER MECHANISM

INTRODUCTION

This section contains preventive maintenance procedures, including cleaning and lubrication instructions. A description of record changer operation is included along with complete adjustment instructions.

Cleaning and lubrication procedures should be performed at regular intervals specified, while adjustments should be made only when necessary.

PREVENTIVE MAINTENANCE

CLEANING

In addition to cleaning the cabinet exterior each time the location is visited, clean the cabinet interior every three to six months, as required. Keeping the cabinet interior clean reduces dust, resulting in increased record and component life. Always clean the phonograph cabinet prior to lubrication.

1. Use a vacuum cleaner, if available to remove heavy dust deposits.

WARNING

USE SOLVENTS IN A WELL-VENTILATED AREA ONLY; DO NOT USE SOLVENTS OF ANY TYPE ON PLASTIC PARTS.

2. Use a clean, lint-free cloth saturated in denatured alcohol to clean mechanical parts.
3. Clean electrical parts using a clean, dry cloth or camel's hair brush.
4. Clean the slug rejector as specified in the applicable slug rejector manual. Order the manual directly from the manufacturer of the slug rejector.

5. The encoder board commutator should not require cleaning under normal conditions. If cleaning is required, first remove the clear plastic window from the encoder housing and proceed as follows:

- Using a clean cloth and alcohol solvent, gently clean the surface of the commutator board.
- Release the magazine detent pawl from the detent wheel and rotate the magazine to gain access to the entire surface of the board.
- Be careful not to disturb the positioning or tension of the wiper fingers. Do not apply solvent to the clear plastic window.
- Replace the window when cleaning is completed.

FIVE-YEAR LUBRICATION (See Figure 2-21)

Your phonograph requires lubrication only after five years. To maintain smooth, trouble-free operation, lubricate the record changer mechanism as shown:

- One Drop F-1379 Light Machine Oil

Do Not Over - Lubricate

Do Not Use Oil or Grease on Solenoid Plungers.

RECORD CHANGER MECHANISM OPERATION

The following paragraphs contain a brief explanation of the operation of the record changer mechanism. The mechanism holds 100 records and plays selections on command from the selection system. Identification and location of each major component is shown in figure 2-20. The purpose and description of each component is explained in the following text.

Selection Counter. The selection counter is mounted to the left of the turntable and accumulates the total number of plays on the phonograph.

Magazine, Belt and Transfer Arm. The record magazine stores 100 7-inch 33 or 45 rpm records in a circular cage. A seamless belt around the cage keeps records in position when they are at the bottom of the gripper bow bracket, above the cage. The rollers permit the transfer arm to clear the belt when removing and returning records to the magazine and also maintain belt tension.

Encoder Assembly. The encoder consists of a rotating commutator disc and a stationary set of wiper contacts which complete circuits to the memory unit and mechanism control unit. The commutator disc contains 100 segments corresponding directly to selections in the record magazine. The disc is driven by the magazine motor.

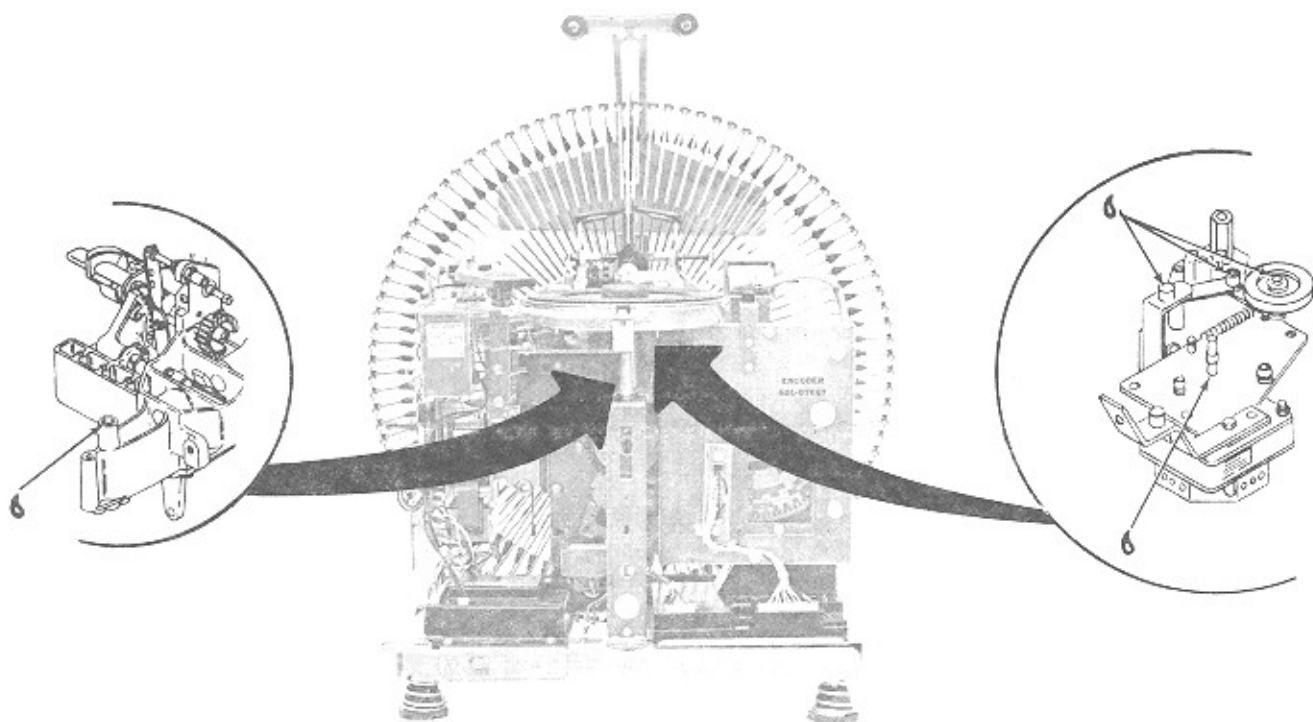
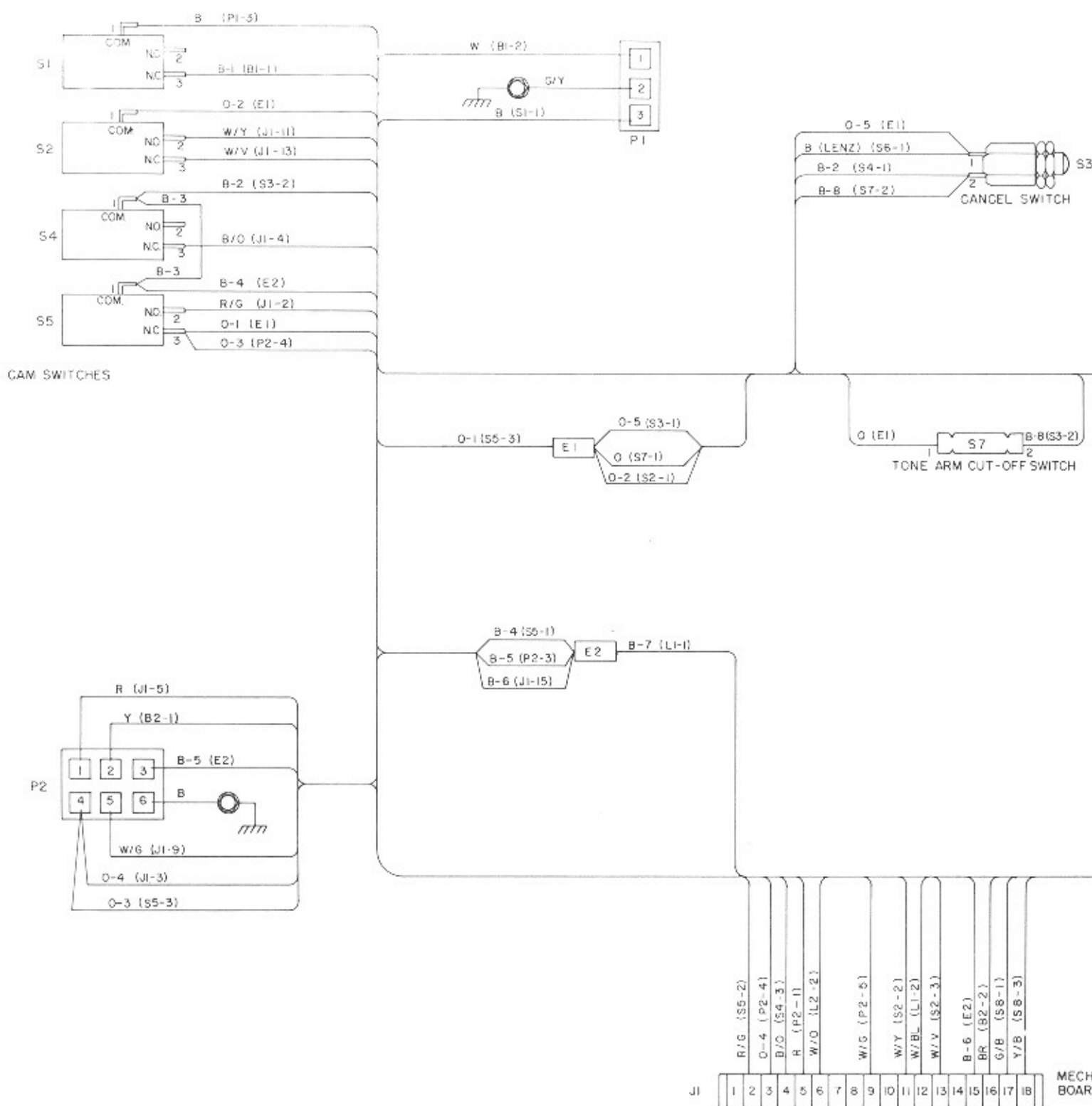
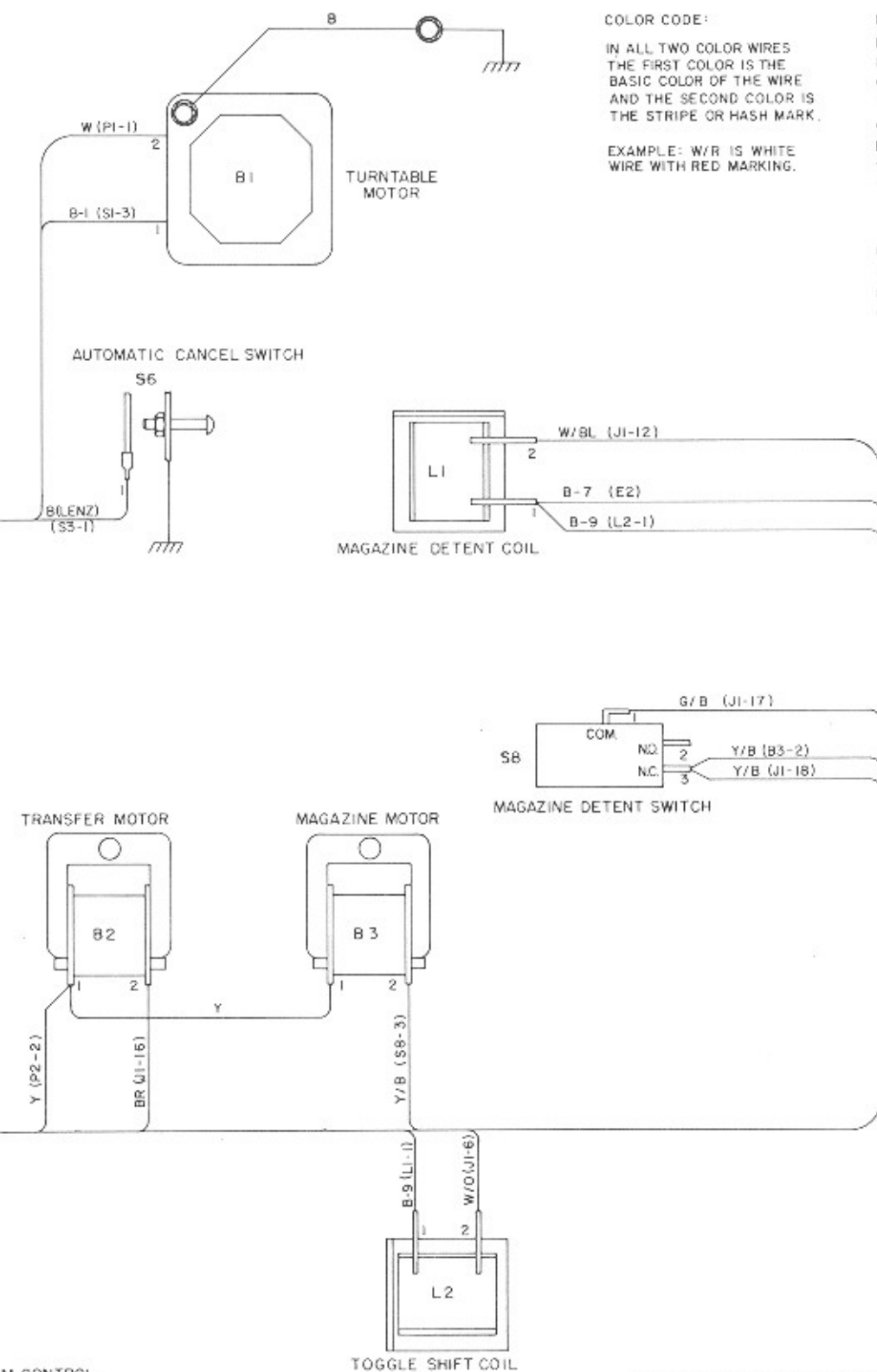

FIGURE 2-21. PHONOGRAPH LUBRICATION





COLOR CODE:
 IN ALL TWO COLOR WIRES
 THE FIRST COLOR IS THE
 BASIC COLOR OF THE WIRE
 AND THE SECOND COLOR IS
 THE STRIPE OR HASH MARK.
 EXAMPLE: W/R IS WHITE
 WIRE WITH RED MARKING.

B	BLACK
BR	BROWN
R	RED
O	ORANGE
Y	YELLOW
G	GREEN
BL	BLUE
V	VIOLET
W	WHITE

NOTE:
 REFERENCE DESIGNATIONS ARE FOR
 REFERENCE ONLY AND DO NOT
 NECESSARILY APPEAR ON PART.

M CONTROL
 CONNECTOR

EQUIV. ENGG. DWG NO 6-03065-01-Q-1
 FOR SCHEMATIC DIAGRAM SEE 6-08000-03-Q-2

6-03065-01-Q-1

FIGURE 2-22. RECORD CHANGER MECHANISM WIRING DIAGRAM

Memory Unit. The memory unit contains digital circuits which receive and store selections from the selector logic unit. The memory matches encoder disc segments against the stored data and commands the mechanism control unit to deenergize the magazine motor and detent coil and operate the record transfer motor and toggle shift coil, if required. In addition, the memory unit houses the auto play feature. Auto play enables the phonograph to play a flip side selection, completely at random, every 20 or 40 minutes as desired, or continuously.

Also included in this package is a battery unit. The battery unit maintains voltage to the memory unit to retain selections if power to the phonograph is interrupted. The unit incorporates three long-life NICAD batteries and a built-in charger. The batteries are charged automatically during normal phonograph operation.

Mechanism Control Unit. This solid state switching unit controls the scan, transfer and toggle shift functions. The unit is switched by the memory unit through the encoder assembly.

Toggle Shifter Coil. The coil drives a linkage which rotates the transfer arm for right side selections. The linkage is spring loaded and will rotate the transfer arm for left side selections when the coil is deenergized.

Magazine Motor and Detent Assembly. This assembly operates the record magazine and popularity meter and locks the magazine in position. It is located at the center of the record changer mechanism, directly under the record transfer arm. The magazine motor and gear box, located behind the mounting plate, rotates the gears that operate the record magazine, and popularity meter drive. The solenoid operated detent assembly locks the magazine in place.

Tone Arm Assembly. The tone arm assembly plays records after they are positioned on the turntable by the record transfer arm. The tone arm contains a stereo cartridge with a diamond stylus that is designed to track at four to five grams pressure. The stylus plugs into the cartridge for easy replacement. A seven-pin receptacle on the tone arm assembly mates with a plug to connect the cartridge to the pre-amplifier via 4-conductor shielded cable.

Turntable Motor and Plate Assembly. The turntable motor and plate assembly consists of the turntable motor and associated components necessary to rotate the turntable. The turntable motor rotates a rubber idler wheel, mounted on a spring-loaded idler arm. The idler wheel contacts the inner rim of the record turntable. The turntable has heavy mass to reduce wow and flutter. Its upper surface is a rubberized pad to prevent records from slipping and to avoid record damage.

Automix. (Optional) Automix operation enables the phonograph to play both 33 and 45 rpm records in any order. Automix components consist of a speed shift coil, a hub shift coil and a trip wire and switch on the turntable hub.

Cam Switch and Motor Assembly. (See figure 2-23) The cam switch and motor assembly consists of the transfer motor and gear box, a switch cam, and four cam switches. A nylon cam operates the cam switches. The function of each switch is described in Table 2-5.

TABLE 2-5. CAM SWITCH FUNCTIONS

SWITCH	FUNCTION
CS-1	Controls turntable motor.
CS-2	Magazine motor interlock during record transfer stops record transfer in magazine.
CS-4	Operates with CS-5 to sustain beginning of 2 nd half of transfer cycle.
CS-5	Stops record transfer over turntable. Signals memory unit to end transfer and toggle shift signals.

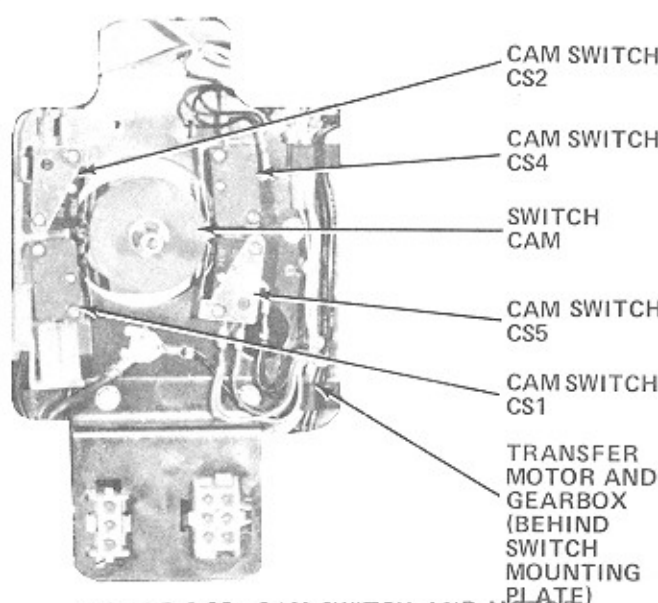

FIGURE 2-23. CAM SWITCH AND MOTOR ASSEMBLY COMPONENTS

ADJUSTMENTS

Record changer mechanism adjustments are listed in Table 2-6. Perform adjustments only when necessary.

TABLE 2-6. RECORD CHANGER ADJUSTMENTS

Adjustment	Page
Magazine Motor and Detent Assembly	2-44
Cam Switch	2-45
Sector Gear	2-46
Tone Arm Cam	2-47
Cam and Trunnion Drive Gear	2-47
Record Magazine Transfer Arm Support	2-48
Magazine Belt	2-49
Aligning Magazine Stopping Position	2-49
Tone Arm	2-50
Automix (Optional)	2-53
Encoder	2-54

MAGAZINE MOTOR AND DETENT ASSEMBLY ADJUSTMENTS

Obtain 0.015 To 0.025 – Inch Gap Between Detent Pawl And High Point Of Detent Wheel.

1. Release detent pawl from detent wheel.
2. Rotate record magazine until detent pawl is positioned on high point as shown.
3. Loosen mounting screws and position detent coil so that there is an 0.015 to 0.025-inch gap between detent pawl and detent wheel with roll pin against plunger stop.
4. Tighten mounting screws.

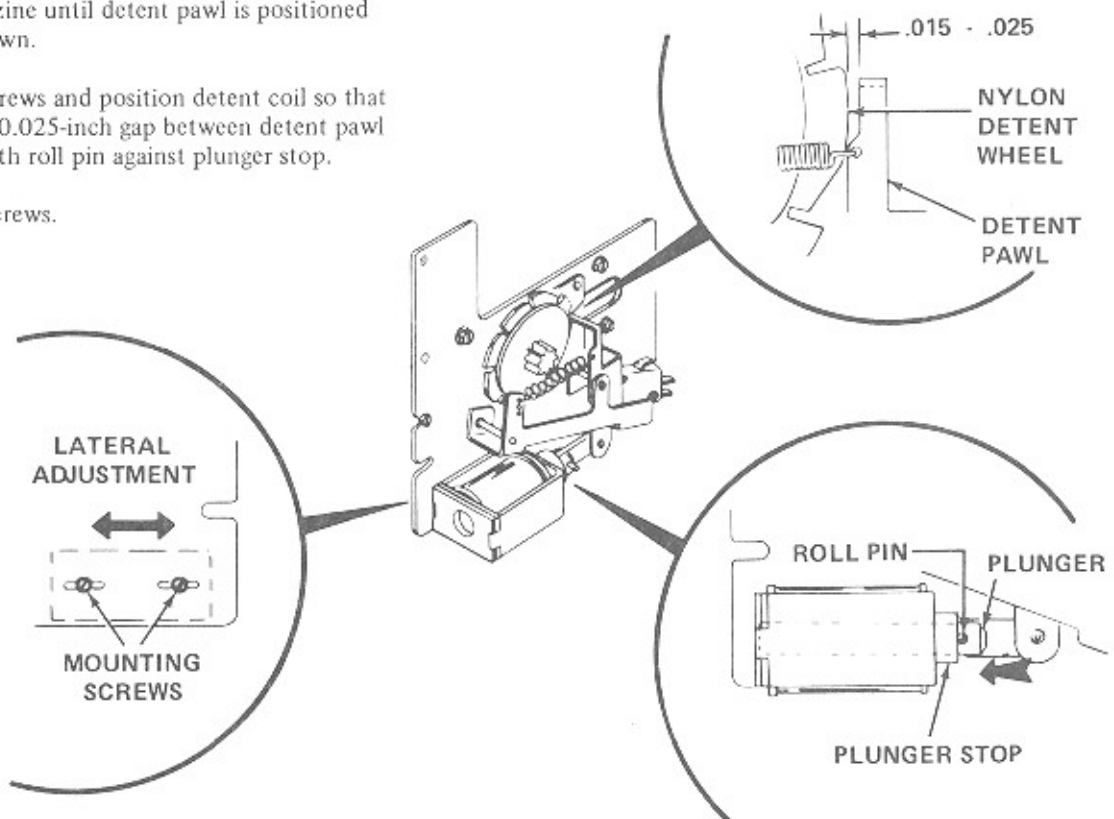

Adjust Magazine Detent Switch.

1. Rotate detent wheel until pawl is seated in notch, locking wheel in place.
2. Turn detent switch actuating screw in until switch just clicks, then turn screw in 1/2 turn more for stable adjustment.

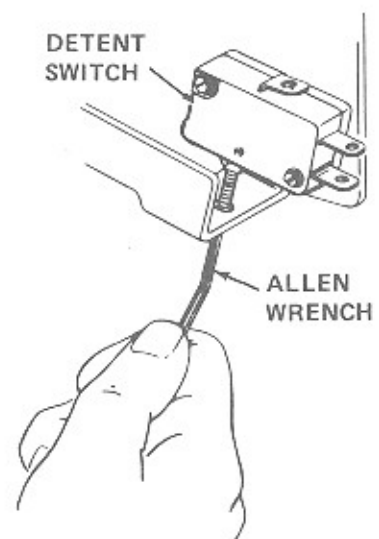

CAM SWITCH ADJUSTMENTS

Locate Cam In Proper Position

1. Using a 5/32" allen wrench, turn transfer motor clockwise until transfer arm just starts to remove a record from the magazine.
2. At this point, the high surface of the cam must be 90° from the horizontal, pointing up. Since cam is keyed to shaft, it can only be in this position, or 180° out of position and pointing downward in error.
3. If necessary to reposition cam, remove retaining ring from shaft and pull cam forward on shaft.
4. Locate cam so that high surface points up, 90° from the horizontal, as shown.
5. Push cam in and secure with retaining ring.

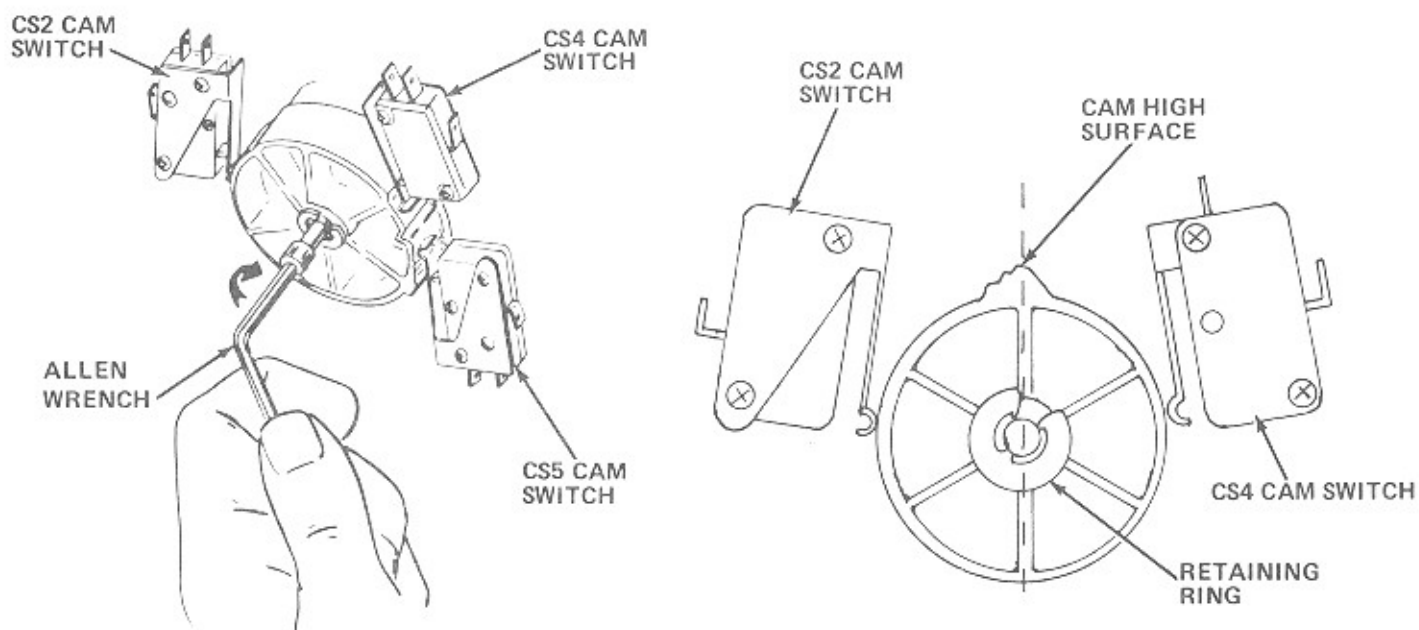

Check And Adjust Cam Switch Operation

1. Check that each cam switch operates (on and off) within center cam step.
2. To adjust a switch, loosen mounting screw closest to actuator end and move switch housing accordingly.
3. Tighten mounting screw and recheck operation.

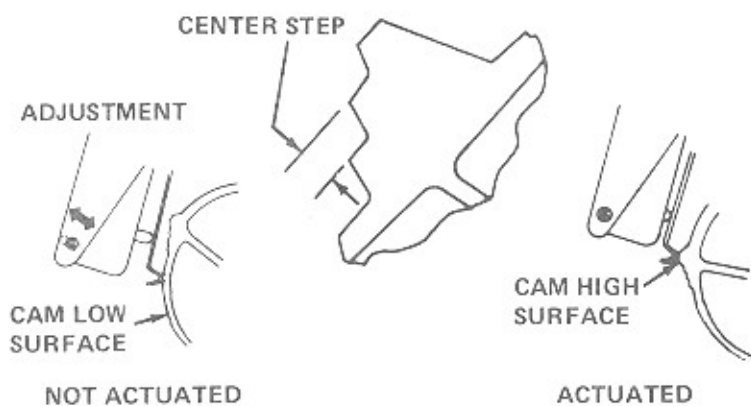

SECTOR GEAR ADJUSTMENTS

Adjust The Sector Gear Retaining Collar

1. Using a 5/32-inch allen wrench, turn transfer motor shaft clockwise until sector gear is in maximum up, or forward position.
2. Set retaining collar so that roll pin is flush with top surface of toggle shifter link nylon stop. Take all looseness out of sector gear in forward direction.
3. Check that there is no end play in sector gear shaft.

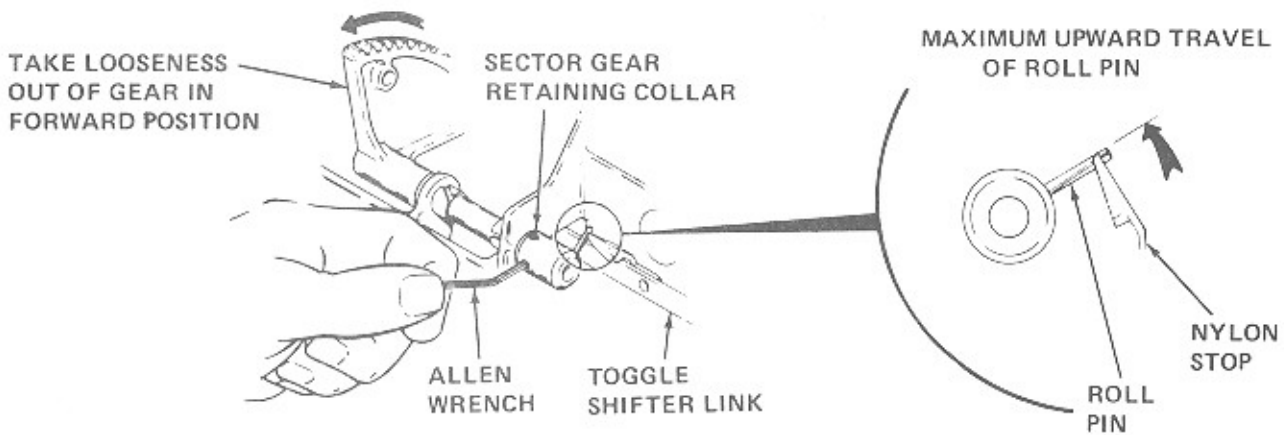
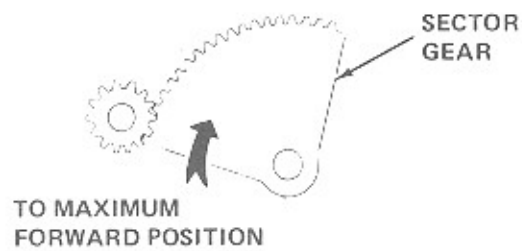
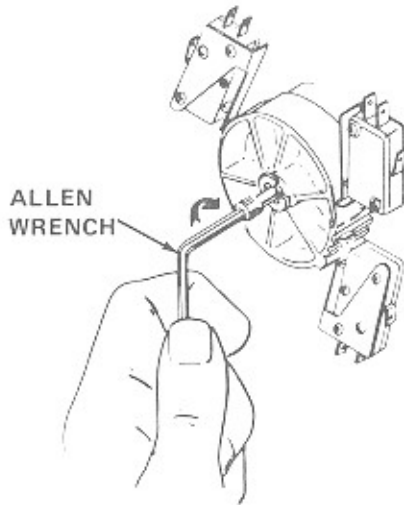

TONE ARM CAM ADJUSTMENTS

Adjust Tone Arm Cam

1. Using a 5/32-inch allen wrench, turn transfer motor shaft clockwise until sector gear is in maximum down position.
2. Loosen allen screws and position tone arm cam so straight cutout in cam surface is 1/8-inch from base casting rear wall front surface plane. Use a 1/8-inch allen wrench to gauge this distance.
3. Remove end play from shaft and tighten allen screws.

NOTE: PINION GEAR TEETH MUST NOT RIDE ON SECTOR GEAR WEB.

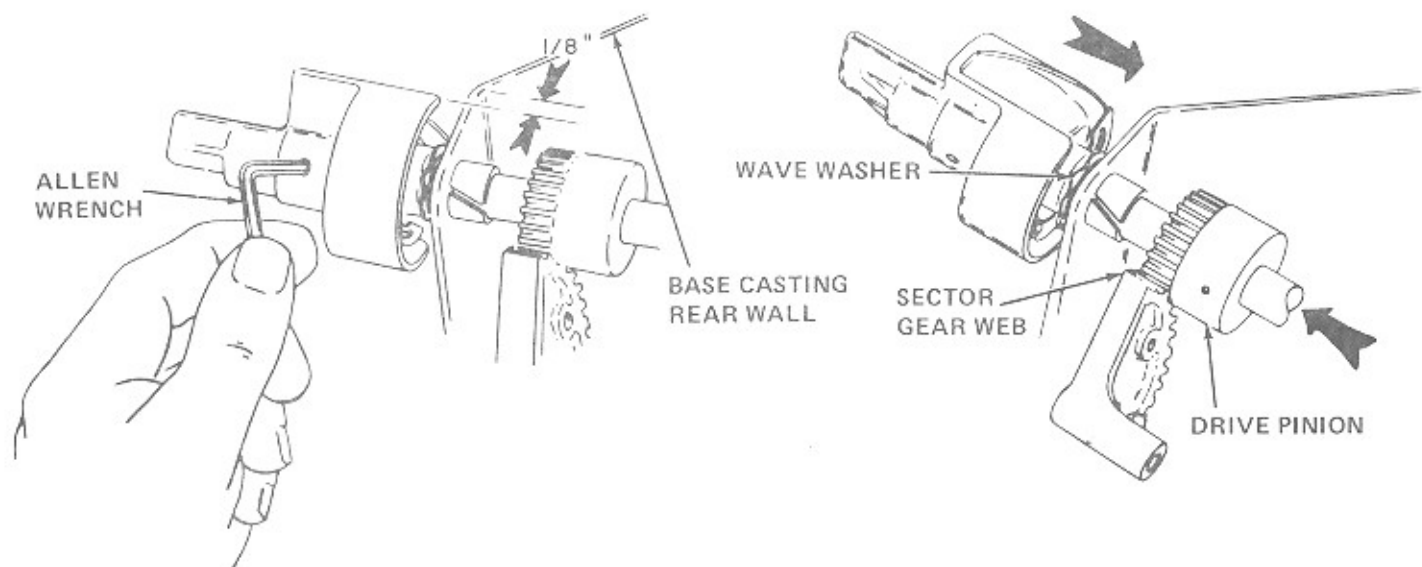

CAM AND TRUNNION DRIVE GEAR ADJUSTMENT

Adjust Cam And Trunnion Drive Gear

1. Using a 5/32-inch allen wrench, turn transfer motor shaft clockwise until sector gear is in maximum down position.

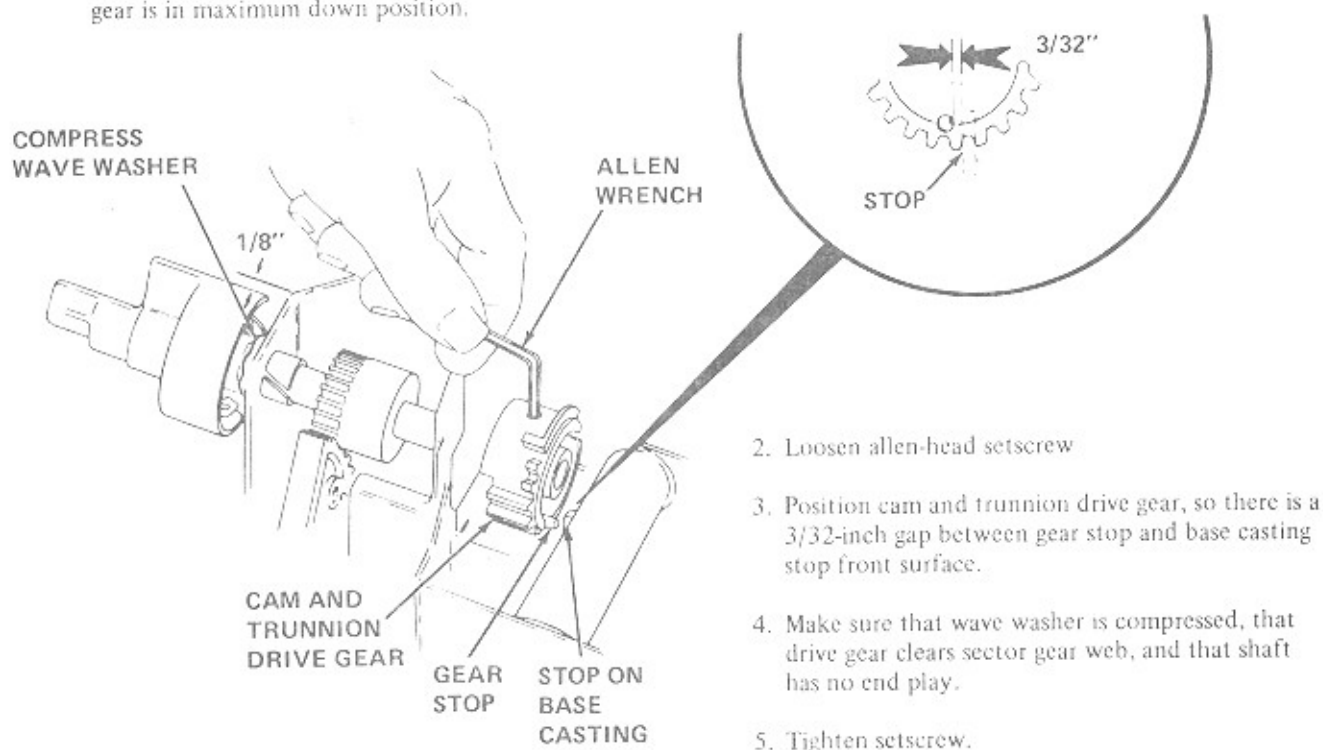

2. Loosen allen-head setscrew
3. Position cam and trunnion drive gear, so there is a 3/32-inch gap between gear stop and base casting stop front surface.
4. Make sure that wave washer is compressed, that drive gear clears sector gear web, and that shaft has no end play.
5. Tighten setscrew.

RECORD MAGAZINE TRANSFER ARM SUPPORT ADJUSTMENT

Eliminate Magazine End Play And Center Transfer Arm Support

1. Loosen setscrews in transfer arm support.
2. Push transfer arm support onto magazine shaft to eliminate end play and adjust it so transfer arm will not rub on either side of opening.
3. Tighten screws.
4. If slight adjustment is necessary after setscrews are seated, loosen three screws on rear of transfer arm support, adjust, and tighten screws.

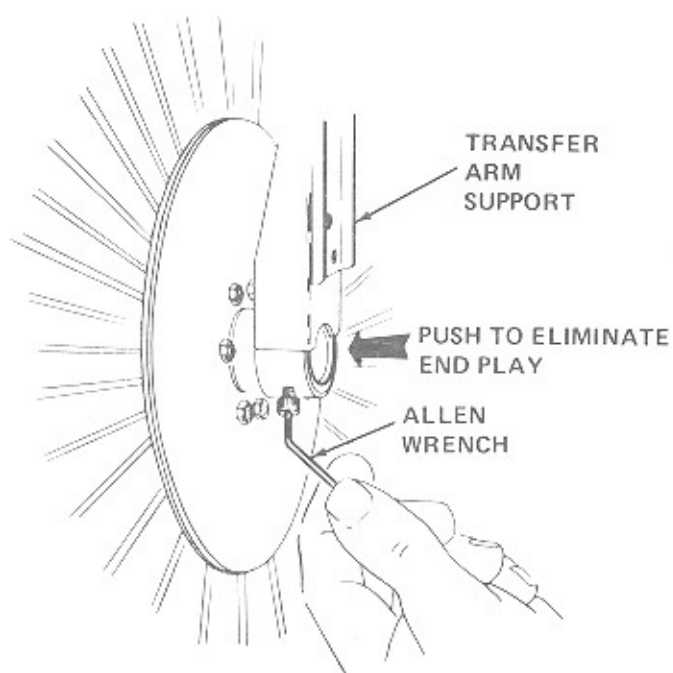
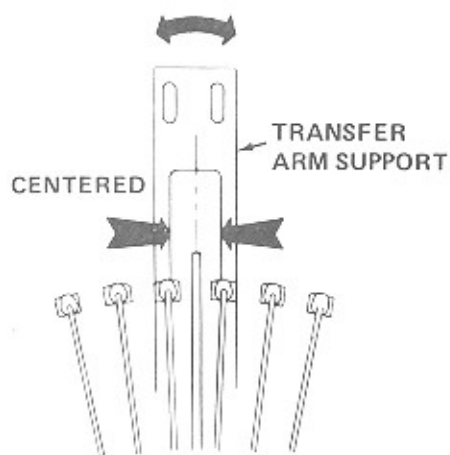
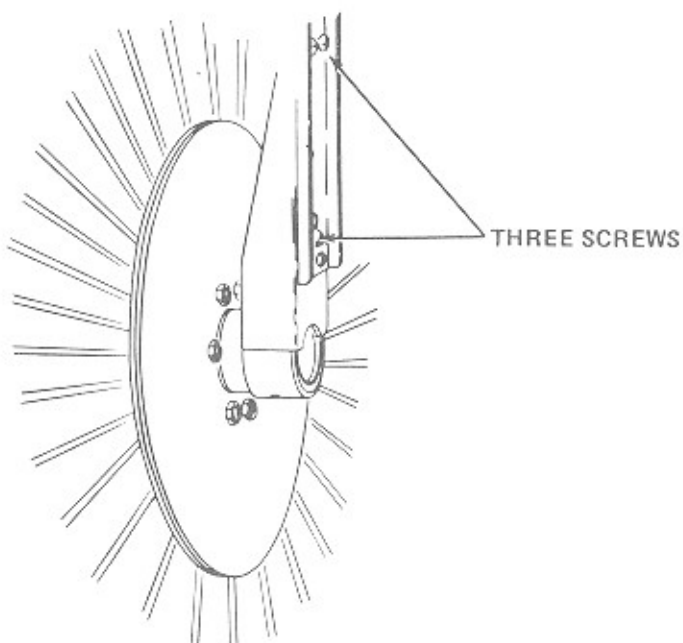

MAGAZINE BELT ADJUSTMENT

Tighten Magazine Belt

1. Loosen two adjustment screws shown.
2. Raise bracket to tighten belt around magazine.
3. Check that belt rides evenly in center of belt guides, all the way around the magazine.

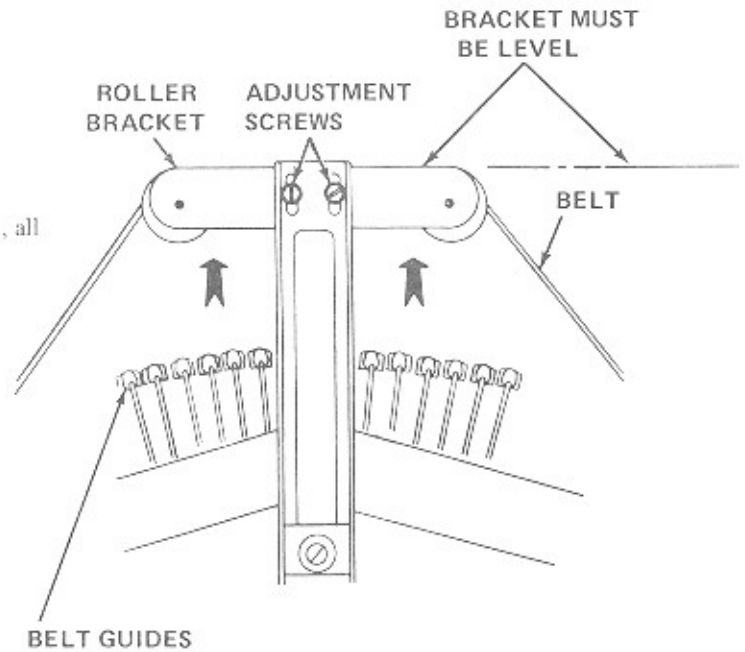

ALIGNING MAGAZINE STOPPING POSITION WITH TRANSFER ARM

Align Stopping Position Of Magazine With Transfer Arm

1. Rotate magazine until selection OO is at top center. Allow magazine detent to engage and lock magazine in place.
2. Loosen two screws in large nylon gear.
3. With detent wheel locked, move magazine until transfer arm is centered in record slot.
4. Tighten two screws in large nylon gear securely.

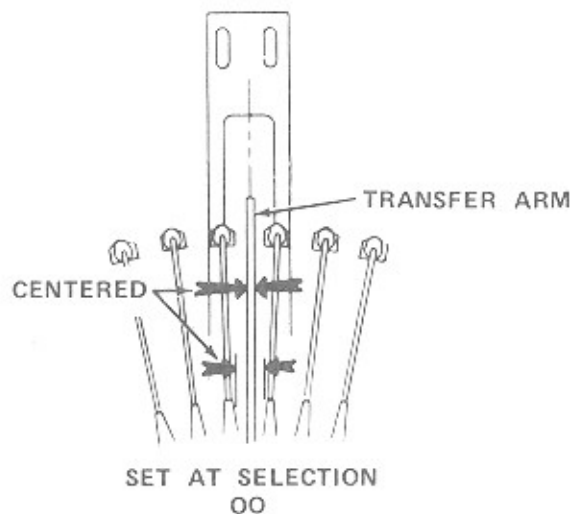
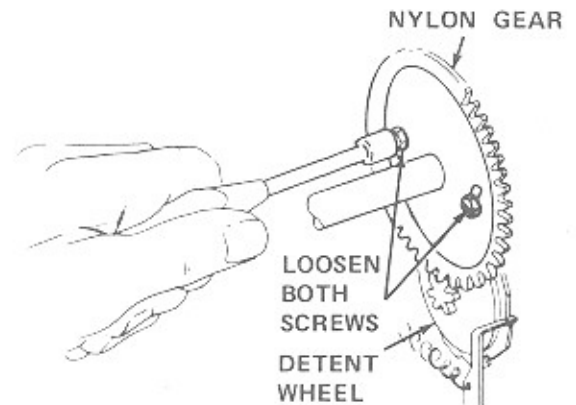
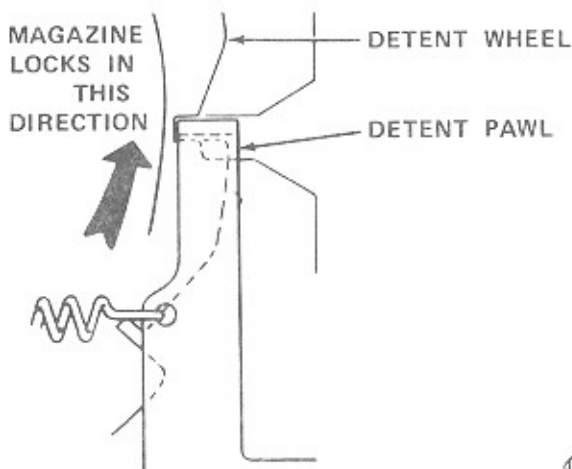

STONE ARM ADJUSTMENTS

Adjust Vertical Pivot

1. Adjust tone arm pivot screw so that tone arm pivot is loose enough to move free vertically for a distance of two inches above turntable.
2. Check that tone arm moves less than 1/32 inch from side to side.

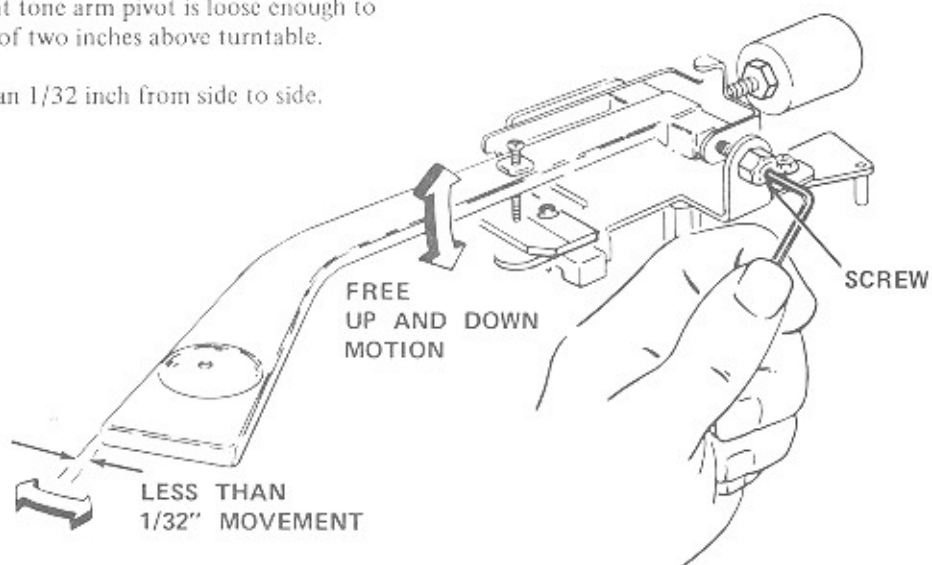

Set Stylus Force

1. Loosen lock nut.
2. Attach a suitable gram gauge to tone arm as shown. Adjust counterweight for 4 to 5 grams pressure.
3. Tighten lock nut against counterweight and recheck adjustment.

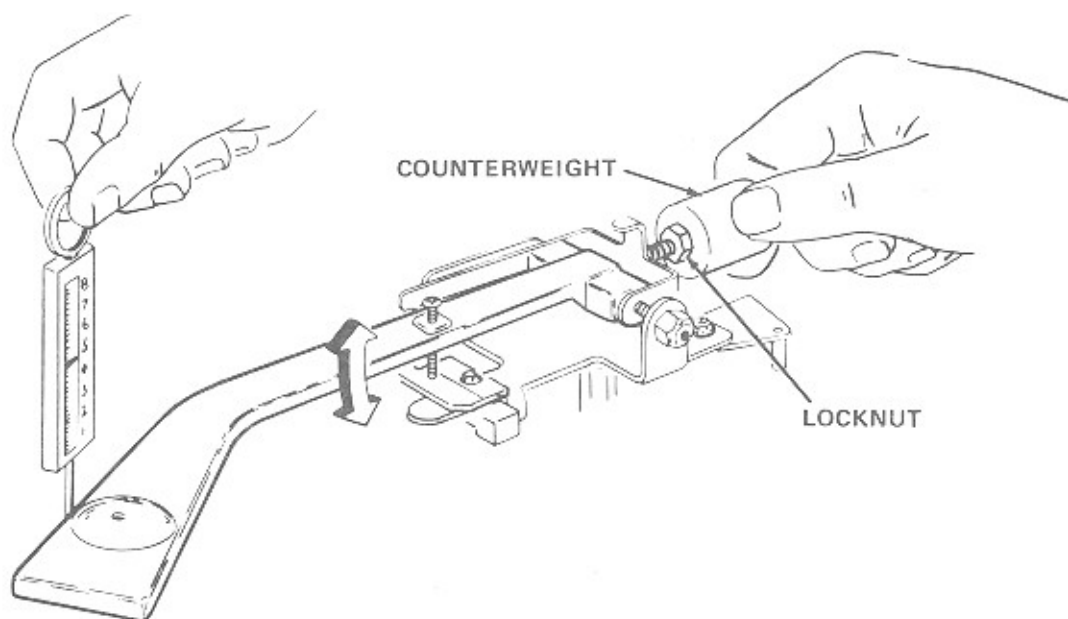

tone arm adjustments (CONTINUED)

Set Stylus Clearance

1. Operate transfer assembly to place transfer arm next to tone arm.
2. Stylus must clear transfer arm by $1/32''$ maximum as tone arm swings over it. Adjust clearance by bending long arm of tone arm rest, as necessary, at point shown.

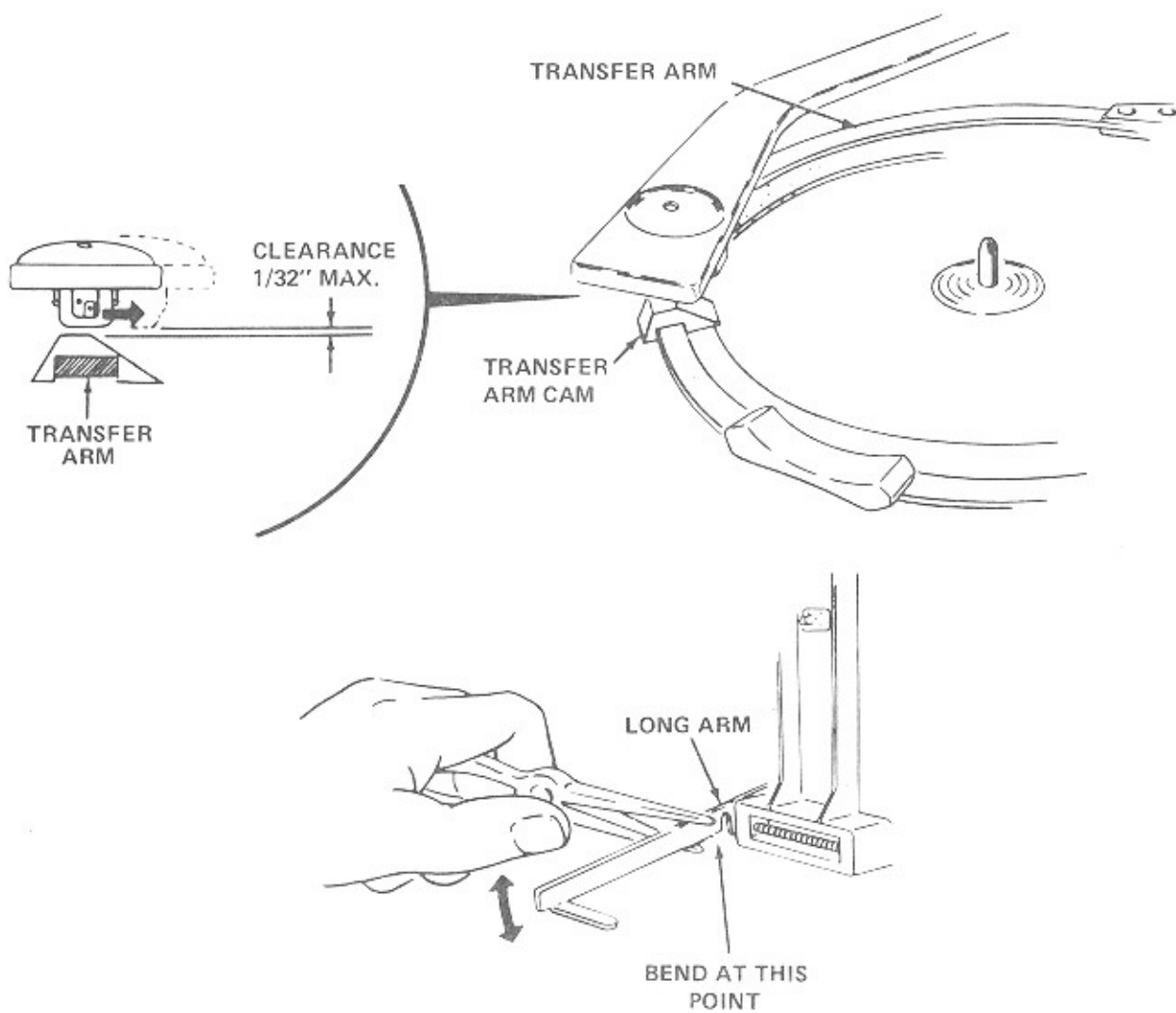

tone arm adjustments (continued)

Set Stylus Height

1. Operate transfer assembly to position tone arm over turntable rim.
2. Turn adjustment screw until needle housing is 1/32-inch above turntable pad surface with tone arm in play position.

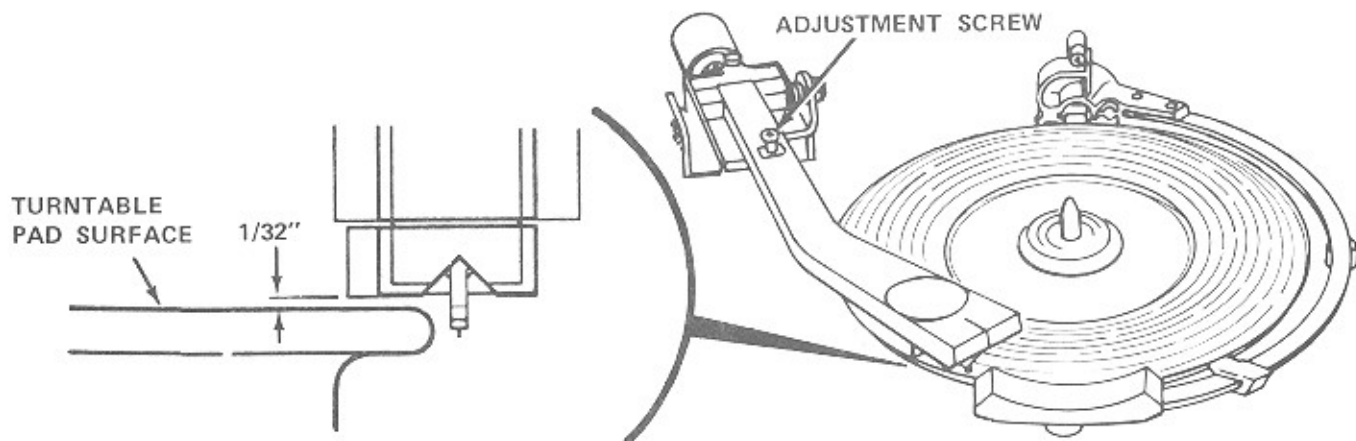

Set Stylus Setdown Position And Tone Arm Cutoff Switch

1. Place undersize (6-13/16-inch diameter) record on turntable.
2. Operate transfer assembly to bring tone arm to play position.
3. Loosen mounting screw.
4. While holding cam follower plate against tone arm cam, move tone arm, as required, until stylus is 2-9/16 inches from the turntable hub.
5. Tighten mounting screw and check adjustment.
6. Locate tone arm stylus in record cutout groove.
7. Loosen two mounting screws on cutoff reed switch mounting plate.
8. Position mounting plate, as necessary until reed switch is closed. The magnet on the under side of the tone arm operates before stylus enter "closed" record groove.

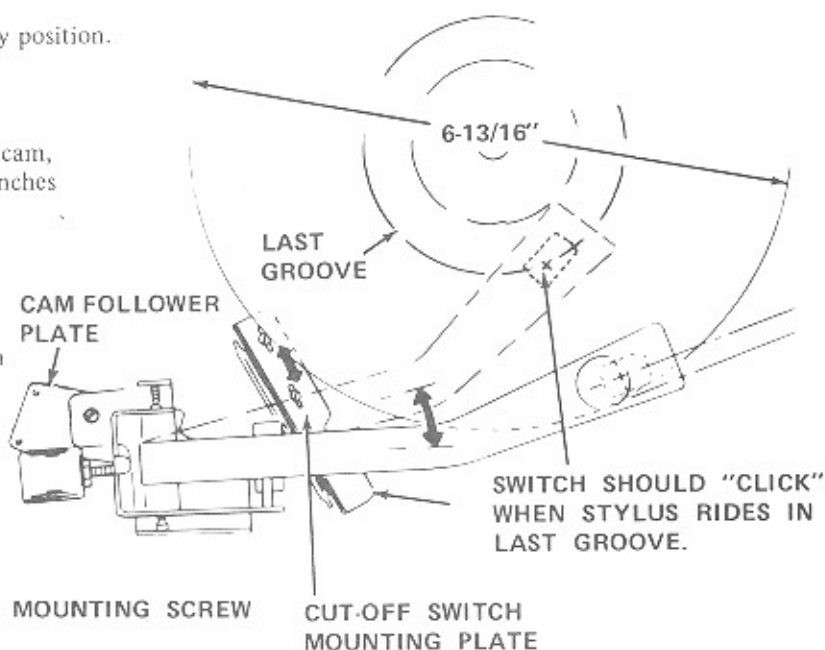

AUTOMIX ADJUSTMENTS (Optional)

Obtain 1/32-inch Gap Between Sensing Wire And Turntable Spindle Retaining Ring

1. Loosen mounting screws and move hub switch down as far as slotted mounting.
2. While holding plunger all the way up, raise hub switch until a 1/32-inch gap exists between sensing wire and turntable spindle retaining ring.
3. Tighten switch mounting screws.

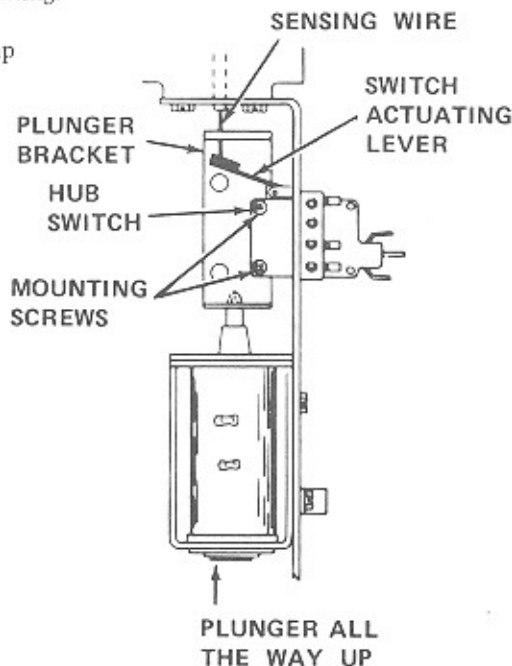
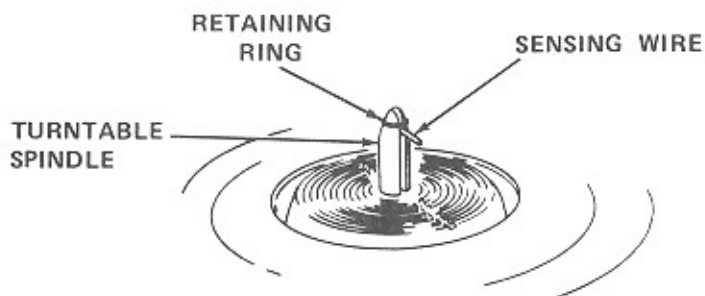

Adjust Speed Shift Coil So That Idler Wheel Rim Clears Motor Shaft Step By At Least 1/32 Inch

1. Loosen speed shift coil mounting screws.
2. Adjust speed shift coil so that idler wheel clears motor shaft step by at least 1/32-inch in both full up and full down coil plunger position. The speed shift coil frame will pivot slightly about the top mounting screw hole, just enough to allow up and down adjustment of the idler linkage.

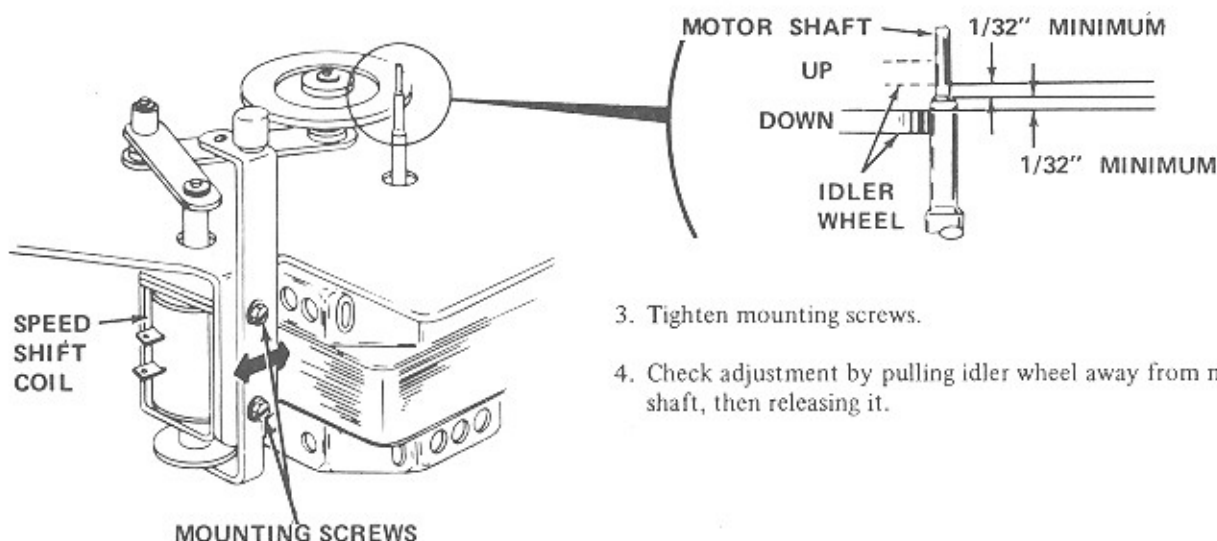

3. Tighten mounting screws.
4. Check adjustment by pulling idler wheel away from motor shaft, then releasing it.

ENCODER ADJUSTMENTS

Align Encoder Gear

1. Release magazine detent pawl from detent wheel and rotate record magazine until selection 00 is at the top center. Engage the pawl, locking the magazine in place.
2. Loosen three large bolts securing encoder and pull forward 3/16 inch so that the encoder gear disengages the nylon gear.
3. Mesh encoder gear with nylon gear so that 00 index mark on the encoder gear is aligned with the step on the encoder mounting bracket as shown.
4. Tighten three encoder mounting bolts.

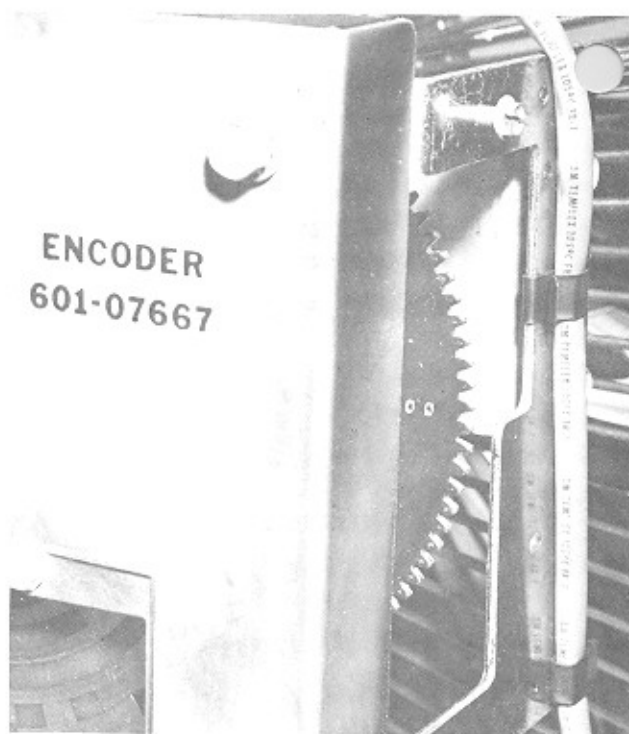
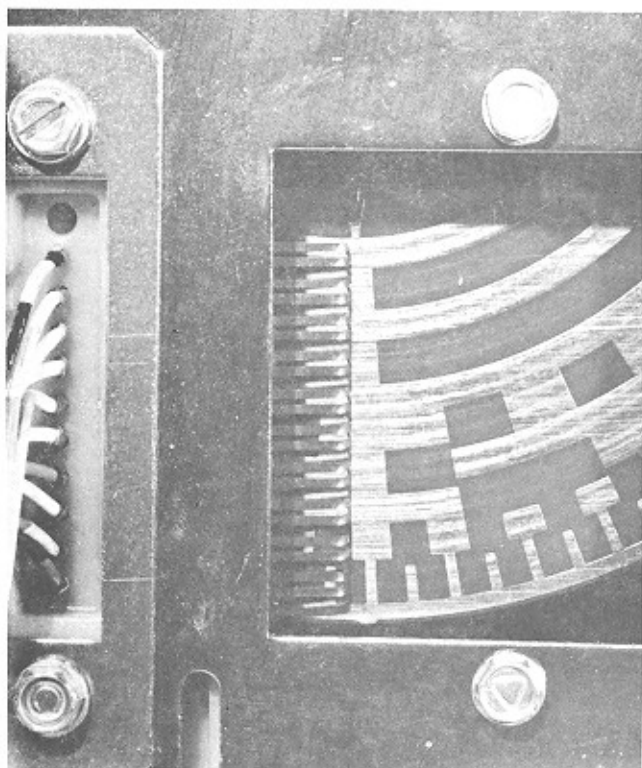

Align Wipers

1. With the encoder gear aligned to the 00 mark, loosen the two mounting screws securing wiper assembly to encoder case.
2. Adjust wiper assembly so that the second wiper from bottom is 1/64 inch to the left of the segment as shown.
3. Tighten screws securing wiper assembly.

Contact Force

Replace wiper assembly if contact force is not as shown below:

