

# SECTION 2- INSTALLATION AND PROGRAMMING

## INTRODUCTION

This section contains instructions for unpacking the phonograph and installing it on location. The phonograph is shipped with all major components in place. Save all tie-down hardware should it become necessary to move the phonograph to another location.

### ACCESSORIES BAG ASSEMBLY

Included is a plastic bag containing slip-on terminals connecting accessories, an assortment of spare fuses and spare contacts for connectors. It is recommended that you leave the Service Manual and the accessory bag assembly in the phonograph cabinet in case they are needed.

### WARRANTY REGISTRATION CARD

A postage-paid warranty registration card is included with the phonograph. Use this card to register the phonograph for in-warranty repairs.

## UNPACKING INSTRUCTIONS

The phonograph is shipped in one carton, ready for installation. The shipping carton should be opened carefully to prevent the phonograph from being damaged or scratched. Inspect the exterior and interior of the cabinet for evidence of damage.

In case of damage, please notify the delivering carrier at once to call and examine the phonograph regardless of the external condition of the boxes. Under U.S. regulations, damage claims must be collected by the consignee. Do not return shipping-damaged merchandise until after your claim has been established. Once your claim is established, damaged merchandise may be returned to the Rowe/AMI distributor for repair. The invoice for repair charges may then be collected from the carrier. Do not destroy packing material or boxes until the carrier's agent has examined them. Unpack the phonograph as follows:

### REMOVE PACKING CASE

1. Carefully open packing case. Do not use shipping hooks or other sharp instruments.
2. Remove plastic bag from phonograph cabinet.

### OPEN PHONOGRAPH CABINET

1. Locate red key bag and open lid.
2. Remove shipping brackets, release latches and open doors.

3. Remove tape from title panel. Release title panel by pressing down on spring catch as shown. Swing panel down as shown.

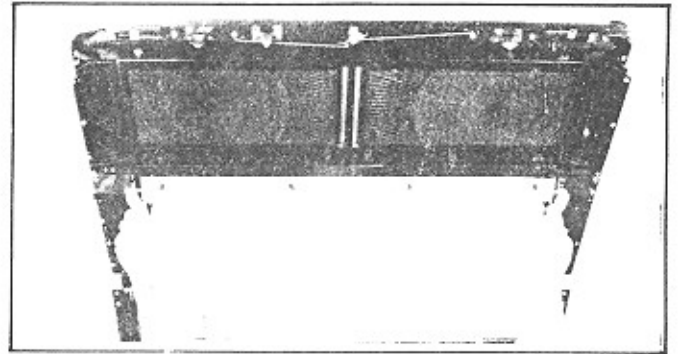

### REMOVE RECORD CHANGER MECHANISM TIE-DOWN BOLTS

1. Remove shipping bolt from rear of cabinet as shown.

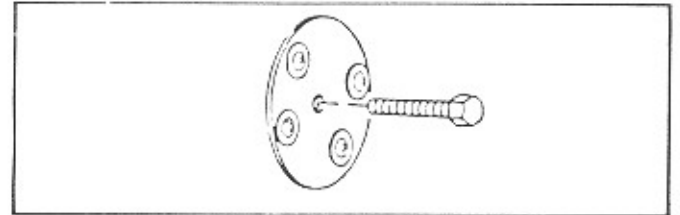

2. Rotate record changer tie-down brackets away from mechanism support frame as shown. Lift up and remove.

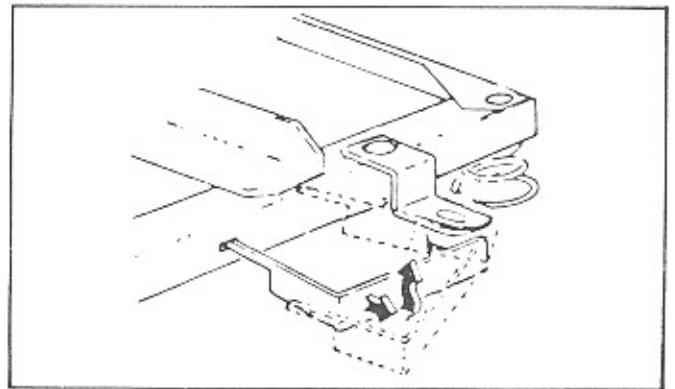

3. Remove rubber bands and shipping block from tone arm.



## PROGRAMMING

4. Remove turntable hold-down clip. Replace screw.
5. Remove stylus cover from cartridge and stylus.
6. Save shipping hardware for future use.
7. Remove adhesive tape.
8. Check that all plugs are firmly seated in their respective receptacles.

### LEVEL PHONOGRAPH

Level the phonograph cabinet left-to-right and front-to-back to ensure proper slug rejector operation. This is done by placing spacers under the caster wheels.

This covers pricing, selection system, credit, paymaker.

### PRICING

A new ROWE-AMI exclusive simplified pricing procedure is incorporated in the R-85. All price programming is done on the Pricing Board (6-08878-04). The phonograph is shipped from the factory with prices set at:

7 plays for	\$1.00
5 plays for	.75
3 plays for	.50
1 play for	.25

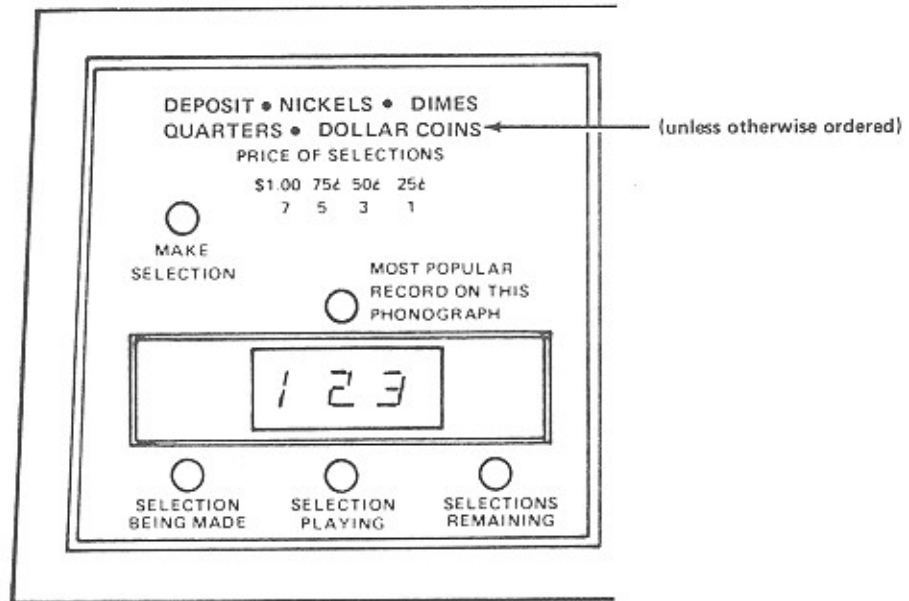

To change pricing open the top door, disconnect the 15 pin connectors. Remove plastic cover. A complete set of price chips is shipped with each phonograph. Select the chips you wish to use and plug them in. Select the matching prices from the universal price card sheet and attach to the price card.

**NOTE**

*We suggest that unused price chips be kept in the phono in the bag they came in for safekeeping. If chips are lost replacements may be ordered from your Rowe-AMI distributor (part no. 2-18507-01 thru -16).*

The Pricing Board has spaces for six chips. One labelled "Premium Ratio" sets the number of standard plays equal to one premium play. This is used only on phonographs programmed for premium play. The Automix Kit (Part No. 2-66681-06 includes a special price card for such phonographs. If the phonograph is not programmed for premium play this chip may be omitted. If the phonograph is programmed for premium play and this chip is omitted, the premium records will be played free provided there is credit on the machine (premium = zero times).

The second chip position labelled "1 play price" sets the price of a single play if less than 25¢. Price chips are provided for single play prices of 5¢, 10¢, 15¢ and 20¢.

The remaining four positions are labelled "Credit Level 1", "Credit Level 2", "Credit Level 3", and "Credit Level 4". In the U.S.A. these levels are factory set at 25¢, 50¢, 75¢, and \$1.00. Select the price chips with numbers of plays desired at each credit level and plug them in.

If any position is programmed for zero (or if a chip is omitted) that level will be ignored. Reassemble the Pricing Board plastic cover. Test to make certain that the price program works as desired by dropping coins or by using the manual credit button (each push = 25¢). Watch the digital display near the selector keyboard to see how many plays you get at each credit level.

The "Make Selection" lamp will light when there is enough credit to make one or more selections. On Phonos which have the Automix Kit installed, the "Make Premium Selection" lamp will light when there is enough credit to make one or more premium selections. A Premium selection will reduce the "Selections Remaining" by an amount equal to the "Premium Ratio".

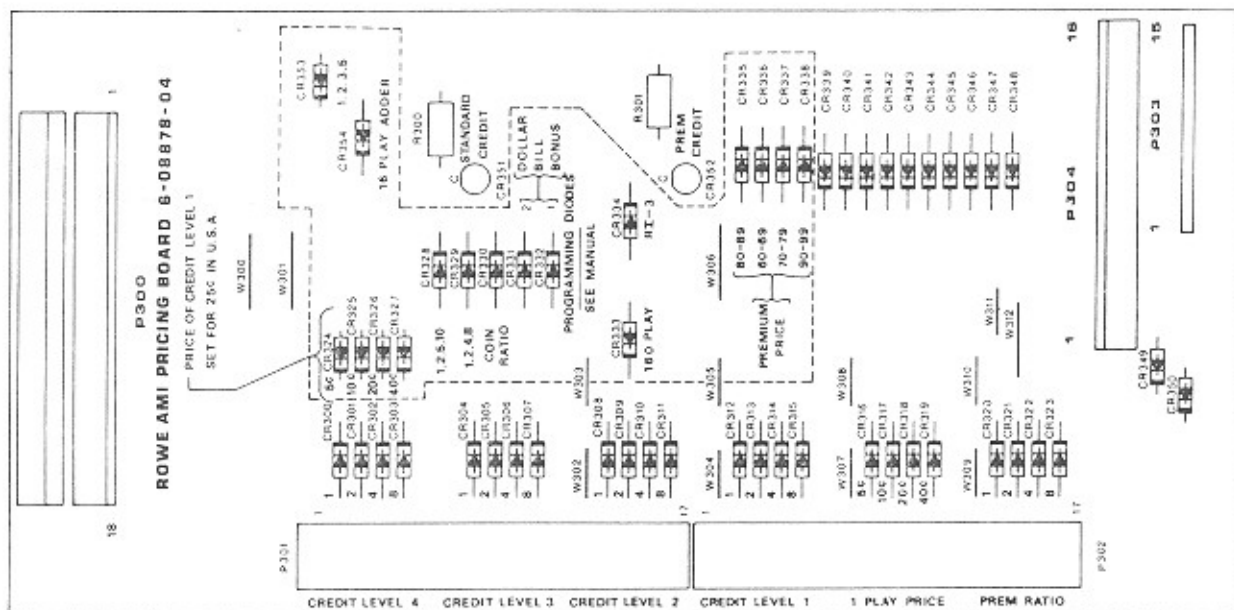

## OPERATIONAL INFORMATION

### STATUS LAMPS

Red indicator lamps are connected to various strategic points in the phonograph circuit to indicate status of power and signal circuits.

#### Power Supply

- + 8 Volts DC
- + 28 Volts DC
- 28 Volts AC

Shows presence of respective voltage and implies that there is no short on the lines

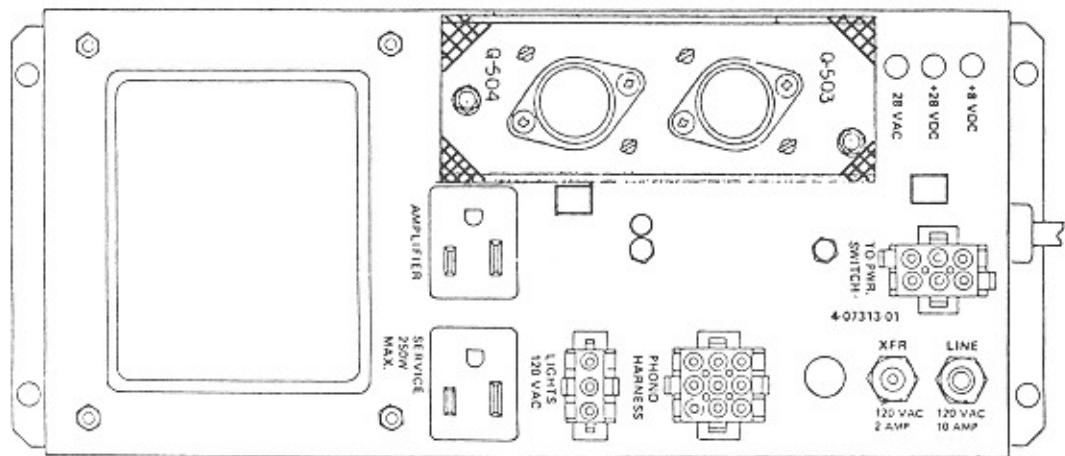

#### Mechanism Control

- |                |   |
|----------------|---|
| T.T. Motor     | Lights when Turn Table motor command is present. Motor should be running  |
| Tran Motor     | Lights when Transfer command is present. Transfer motor should be running.  |
| Mag. Motor     | Lights when Magazine Motor command is present - Motor should be running.  |
| Detent         | Lights when Detent command is present. Detent coil should be actuated. Detent disengaged.   |
| Toggle         | Lights when Toggle command is present. Toggle coils should be actuated. Both toggle pins moved to left.   |
| Opt. Sw. Index | Lights when the Index section of the optical switch sees the tooth space of the magazine drive gear. Flickers when the magazine rotates.                                |
| Opt Sw. Home   | Lights when the Home section of the optical switch sees the hole in the magazine drive gear. Flashes when the magazine record position 99 passes the Transfer position. |
| Cancel         | Lights when the cancel signal line is shorted to ground.  |

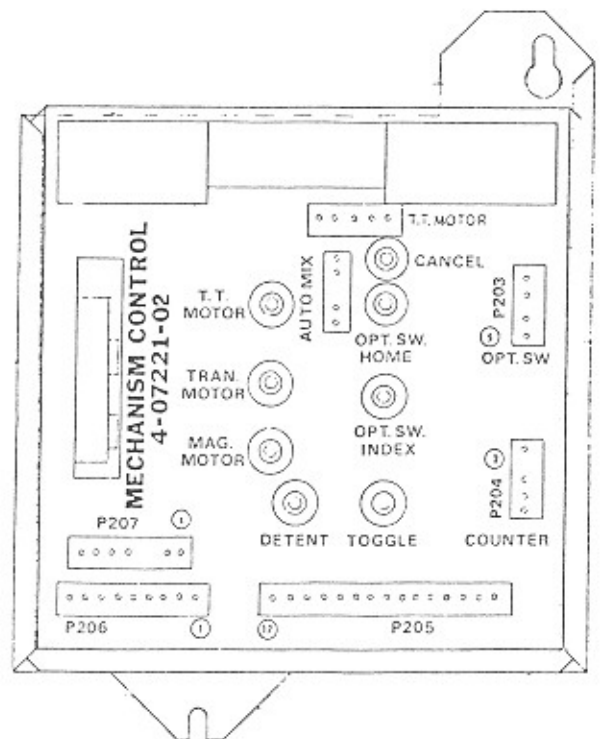

## SOUND SYSTEM

### ACOUSTICAL COMPENSATION (BASS AND TREBLE CONTROLS)

The pre-amplifier contains treble range and bass boost controls to compensate for room acoustics in various locations. These controls are on the amplifier chassis. The sound level at which the phonograph will be operated and the room furnishings determine the settings of these controls. A room with carpeting and drapery is a soft or highly-absorbent location. A crowded room is also highly-absorbent. These locations require higher sound levels. A room with paneled walls and a bare or tiled floor is a hard non-absorbent location. Bass boost and treble range control settings are listed in Table below. Note that more bass boost is required at low volume levels. The amplifier incorporates circuitry that provides extra bass compensation at low volume levels.

### STEREO BALANCE

The stereo balance control is provided to equalize left and right channel amplifier output. This control is factory-adjusted for best performance. If adjustment is required, play a monaural selection and adjust the control for equal sound from each top speaker. When balanced, the sound will seem to come from the center of the phonograph.

### AMPLIFIER OPERATION WITH HIGH LINE VOLTAGE

In locations where input line voltage to the phonograph exceeds 125 volts, use the black/red primary lead of the amplifier power transformer instead of the black/yellow lead. This results in a 10% reduction in secondary voltage.

### AMPLIFIER OPERATION WITH FM, BACKGROUND MUSIC, PAGING, QUAD

This is an optional, add on accessory. See accessory equipment section for explanation of the Amplifier Accessory Kit.

**TABLE 2      USE OF AMPLIFIER CONTROLS FOR ACOUSTICAL COMPENSATION**

SOUND LEVEL IN ROOM	ROOM ACOUSTICS					
	DEAD OR SOFT HIGHLY ABSORBENT		AVERAGE - MODERATELY ABSORBENT		LIVE OR HARD NON-ABSORBENT	
	SET BASS BOOST CONTROL	SET TREBLE RANGE CONTROL	SET BASS BOOST CONTROL	SET TREBLE RANGE CONTROL	SET BASS BOOST CONTROL	SET TREBLE RANGE CONTROL
LOUD	LOW	MOD/MAX	LOW	MOD/MAX	MOD	LIM
MODERATE	LOW	MAX	MOD	MOD/MAX	MAX	LIM
SOFT	MOD	MAX	MAX	MAX	MAX	MOD

Note: Reduce Treble Range setting as required by record noise (scratch) conditions.

## REMOTE VOLUME AND CANCEL CONTROL

Connect the 3-06322-01 remote volume and cancel control to the Phonograph as shown below.

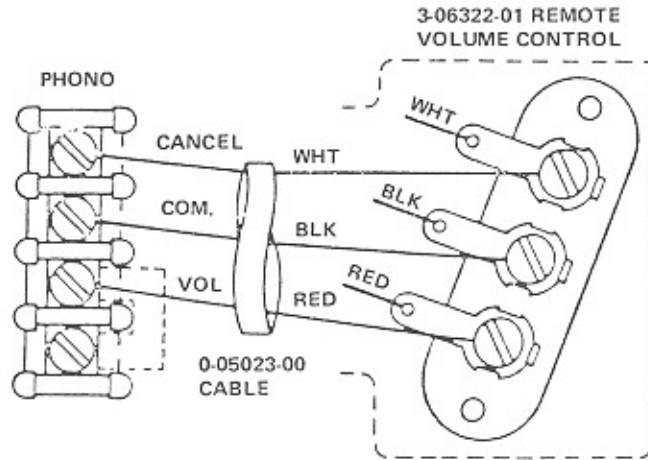

## REMOTE VOLUME AND CANCEL CONTROL WITH POWER SWITCH

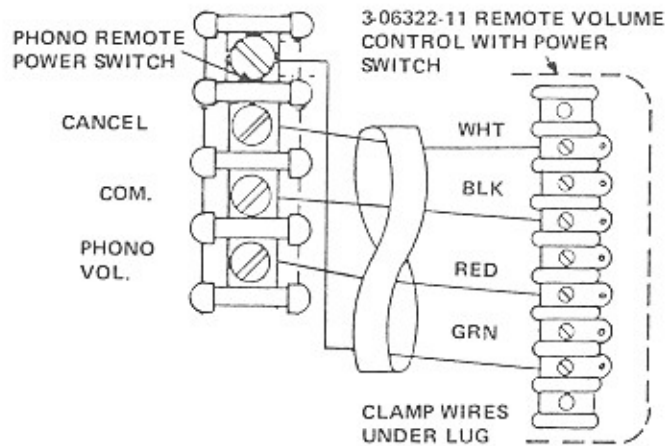

## EXTENSION SPEAKER OPERATION

Care must be exercised when adding extension speakers to the phonograph to avoid poor sound. Three requirements must be met:

1. The speakers must be wired so that the power consumed by the phonograph speakers and the extension speakers, including WalleTTes, does *not* exceed the power rating of the amplifier.
2. The extension speakers should produce the desired sound level relative to the sound level of the phonograph speaker system. This is done by adjusting the amount of power consumed by each speaker until the desired balance is reached.
3. All speakers must be connected with the correct polarity. This means that all speaker cones in the system will move in the same direction at the same time.

Several charts have been included to assist in the connection of extension speakers. Figure 4 is a chart of the entire sound system. NOTE that the left channel output of the amplifier is reversed in phase (or instantaneous polarity) with respect to the right channel. This phase reversal makes monaural extension of sound possible in a stereo system. This phase reversal is accomplished in the preamplifier. Because of this phase reversal, speaker connections to the left channel must be reversed when compared with connections to the right channel except for the 70 volt speaker connections which are in phase. (The left channel is reversed within the output transformer assembly.)

Power to the phono speakers must be reduced as extension speakers are added so that the total speaker power does not exceed the power rating of the amplifier. Table 3 gives connections for different phono speaker power levels and corresponding power available for extension speakers. The phono speakers can be considered as two 8 ohm speakers-one for each channel.

Table 5 and 6 are extension speaker connection charts for different power levels. Power levels are indicated for low impedance speakers as well as for 70 volt speakers. For 70 volt speakers, the power level is set at each speaker. Low impedance speakers, i.e. 8 ohm speakers, can be used where the connecting cable is under 100 feet. The loss in 100 feet of zipcord feeding one 8 ohm speaker is 15%. For two 8 ohm speakers it would be 30%. 4 ohm speakers should not be paralld on the same speaker line because of high line losses. Instead, a separate line from each 4 ohm speaker to the phonograph should be used. To avoid prohibitive cable losses on long speaker lines, 70 volt speakers must be used. These contain built in transformers that permit setting of the desired power level.

Do not connect a low impedance speaker for more power than it can handle. For example, a 5 watt, 8 ohm speaker should not be connected to the 12.5 watt tap.

In any speaker installation, the total power of the speaker load *MUST NOT EXCEED* the power rating of the amplifier. In the system in Figure 4, the power of the speakers as connected is: phono, 28 watts; 8 ohm speakers, 24 watts; 70 volt speakers, 72 watts; walleTte, 2.8 watts for a total of 126.8 watts. This is slightly over the 125 watt rating of the amplifier which is permissible as long as the speaker rating does not exceed the amplifier rating by more than 5%. In any installation, it is advantageous to adjust the speaker load to approximate the rating of the amplifier so that optimum bass boost will be attained at low volume.

### NOTE

*WalleTte speakers are treated as 45 ohm extension speakers in Table 5. For convenience, the left channel speaker in the wallbox has been reversed in polarity.*

PHONOGRAPHER SPEAKER POWER CONNECTION CHART

PHONO SPEAKER POWER LEVEL (TOTAL WATTS)	PHONO SPEAKERS		POWER FOR EXTENSION SPEAKERS	
	LEFT CHANNEL	RIGHT CHANNEL	WATTS PER CHANNEL	TOTAL WATTS BOTH CHANNELS
	VIOLET LEAD	PINK LEAD		
64	E6	E6	31	62
28	E5	E5	49	98
16	E4	E4	55	110
4	E3	E3	61	122
1	E2	E2	62	124
BLACK LEAD TO E1 (COMMON) FOR ALL ABOVE POWER LEVELS	CAUTION: TOTAL POWER RATING OF LOAD MUST NOT EXCEED 65 WATTS PER CHANNEL OR 130 WATTS TOTAL FOR THE 125 WATT AMPLIFIER.			

TABLE 3 PHONOGRAPHER SPEAKER POWER

AMPLIFIER FULL POWER OUTPUT VOLTAGES (PER CHANNEL)

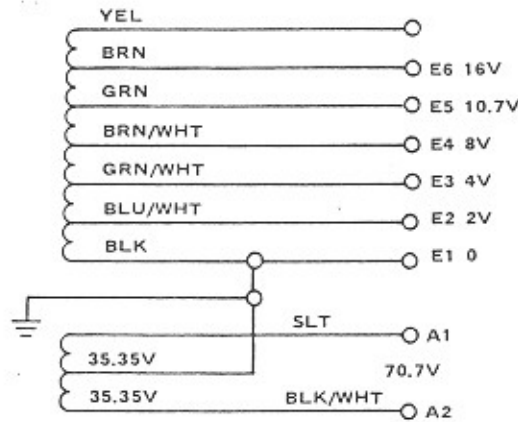
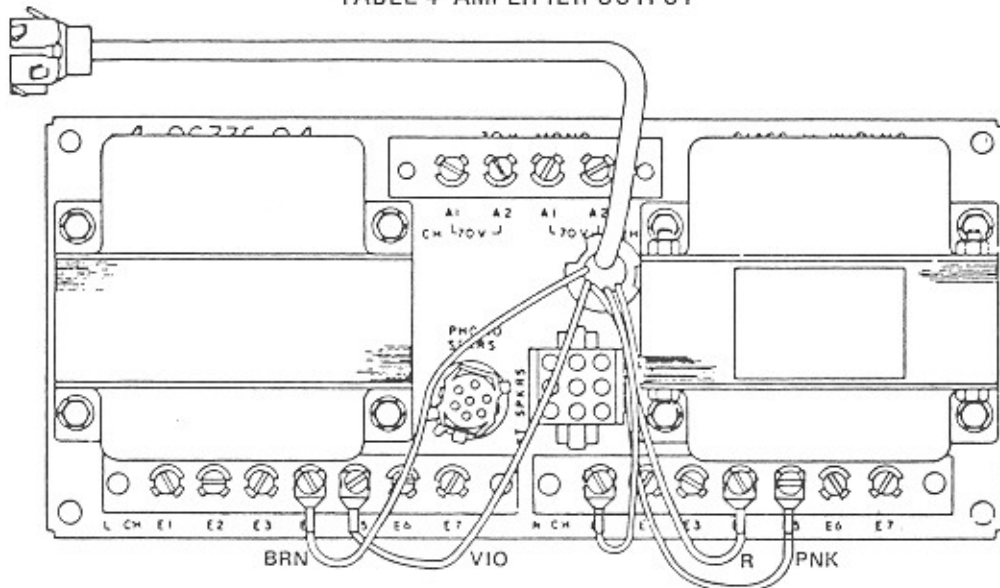

TABLE 4 AMPLIFIER OUTPUT





# STEREO

TABLE 5

## EXTENSION SPEAKER CONNECTIONS

OUTPUT TERMINALS	WATTS PER SPEAKER			
	8 OHM SPEAKERS	4 OHM SPEAKERS	45 OHM WALLBOX	70.7V CONSTANT VOLTAGE SPEAKERS
E1 - E2	0.5	1	0.35	
E4 - E5	0.9	1.75		
E1 - E3	2	4		
E2 - E4	4.5	9	1.4(NORM)	
E1 - E4	8	16	5	
E1 - E5	14	28		
E2 - E6	24			
A1 - A2				DETERMINED BY POWER SETTING AT EXTENSION SPKR

SPEAKERS CONNECTED TO EITHER CHANNEL USED IN PAIRS FOR STEREO EXTENSION OF SOUND.

CAUTION: TOTAL POWER RATING OF LOAD MUST NOT EXCEED 65 WATTS PER CHANNEL OR 130 WATTS TOTAL FOR 125W AMPLIFIER.

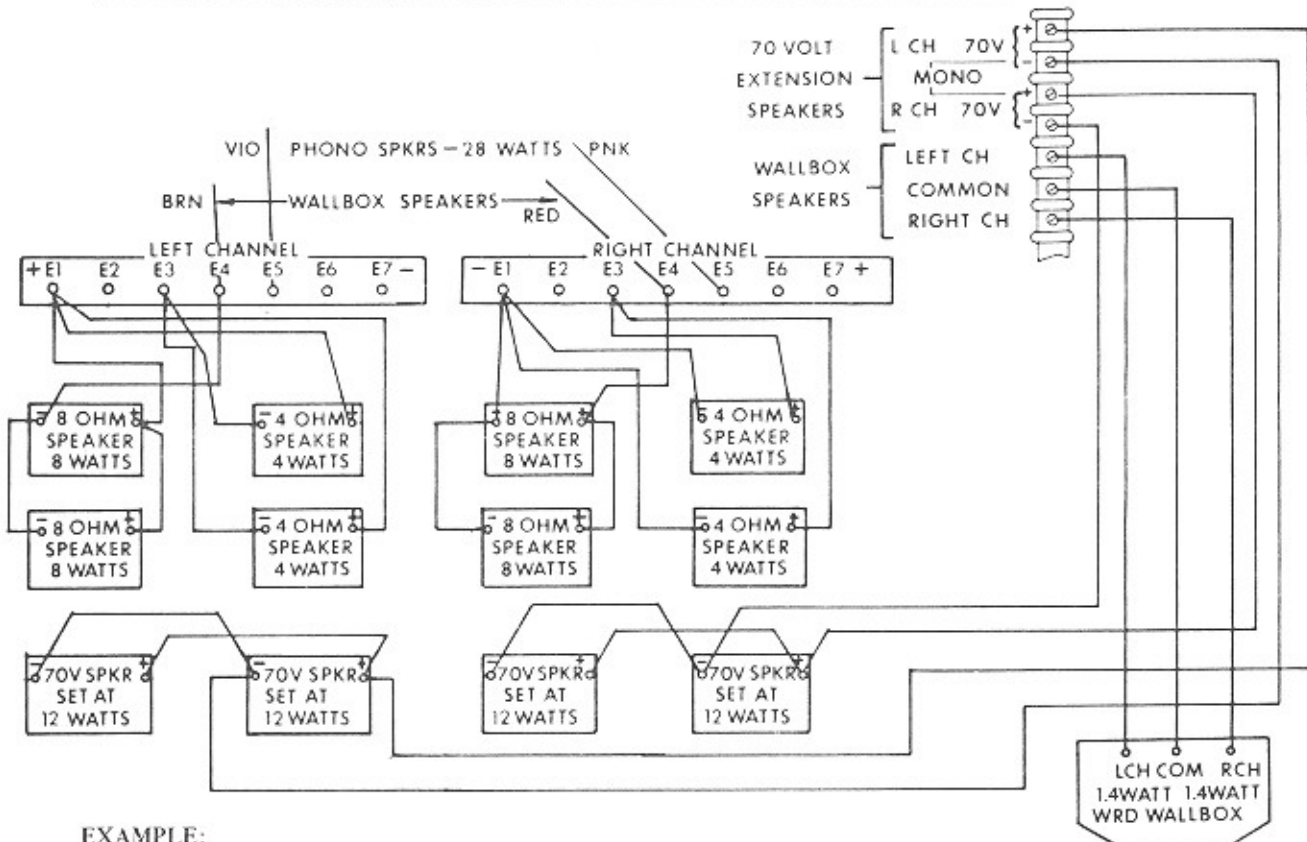

EXAMPLE:

NOTE:

1. Left channel has reversed polarity for low impedance speakers. See page 11.
2. Each 4 OHM speaker is connected directly to terminal strip. See page 11.
3. Add Wattages:

Left Channel:	8 + 8 + 4 + 4 + 12 + 12 + 1.4	= 49.4 Watts
Right Channel:	8 + 8 + 4 + 4 + 12 + 12 + 1.4	= 49.4 Watts
Phonograph (E5-E5)	= 28 Watts	
<b>TOTAL</b>		<b>= 126.8 Watts</b>

4. For speaker impedances not listed in Table 5, use Table 4 and use the impedance method ( $Watts = E^2/R$ ).

# MONAURAL

## EXTENSION SPEAKER CONNECTIONS

OUTPUT TERMINALS	WATTS PER SPEAKER			WATTS PER CHANNEL		
	8 OHM SPEAKERS	4 OHM SPEAKER	70.7 VOLT CONSTANT VOLTAGE SPEAKERS	8 OHM SPEAKERS	4 OHM SPEAKERS	70.7 VOLT CONSTANT VOLTAGE SPEAKERS
E2-E2	2	4		1	2	
E3-E3	8	16		4	8	
E4-E4	32			16		
MONO 70VOLTS						
	POWER SETTING AT EXTENSION SPEAKER			1/2 OF POWER SETTING AT EXTENSION SPEAKER		

TABLE 6

SPEAKERS CONNECTED ACROSS BOTH CHANNELS - FOR MONAURAL EXTENSION OF SOUND.

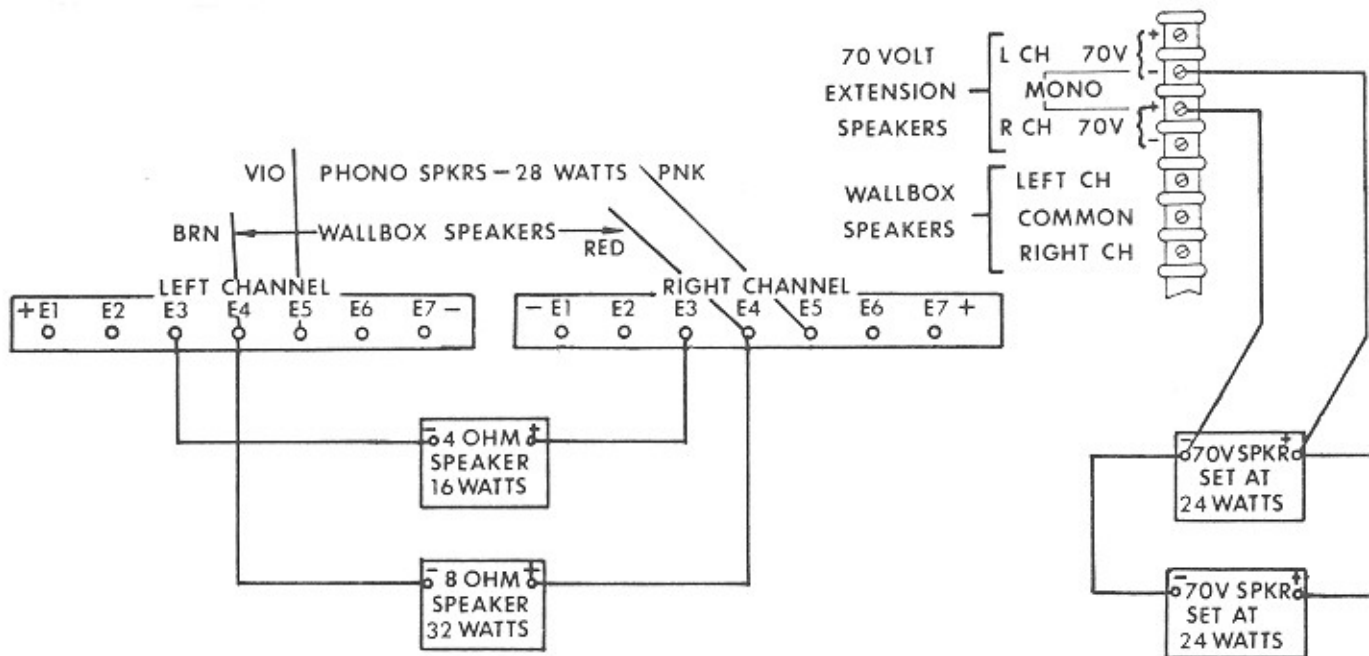

NOTES:

1. Add Wattages:

Extension Speakers:  $16 + 32 + 24 + 24 = 96$  Watts  
 Phonograph (E5 - E5) 28 Watts

TOTAL = 124 Watts

2. For speaker impedances not listed in Table 6, use Table 4 and use the impedance method ( $\text{Watts} = E^2/R$ ).

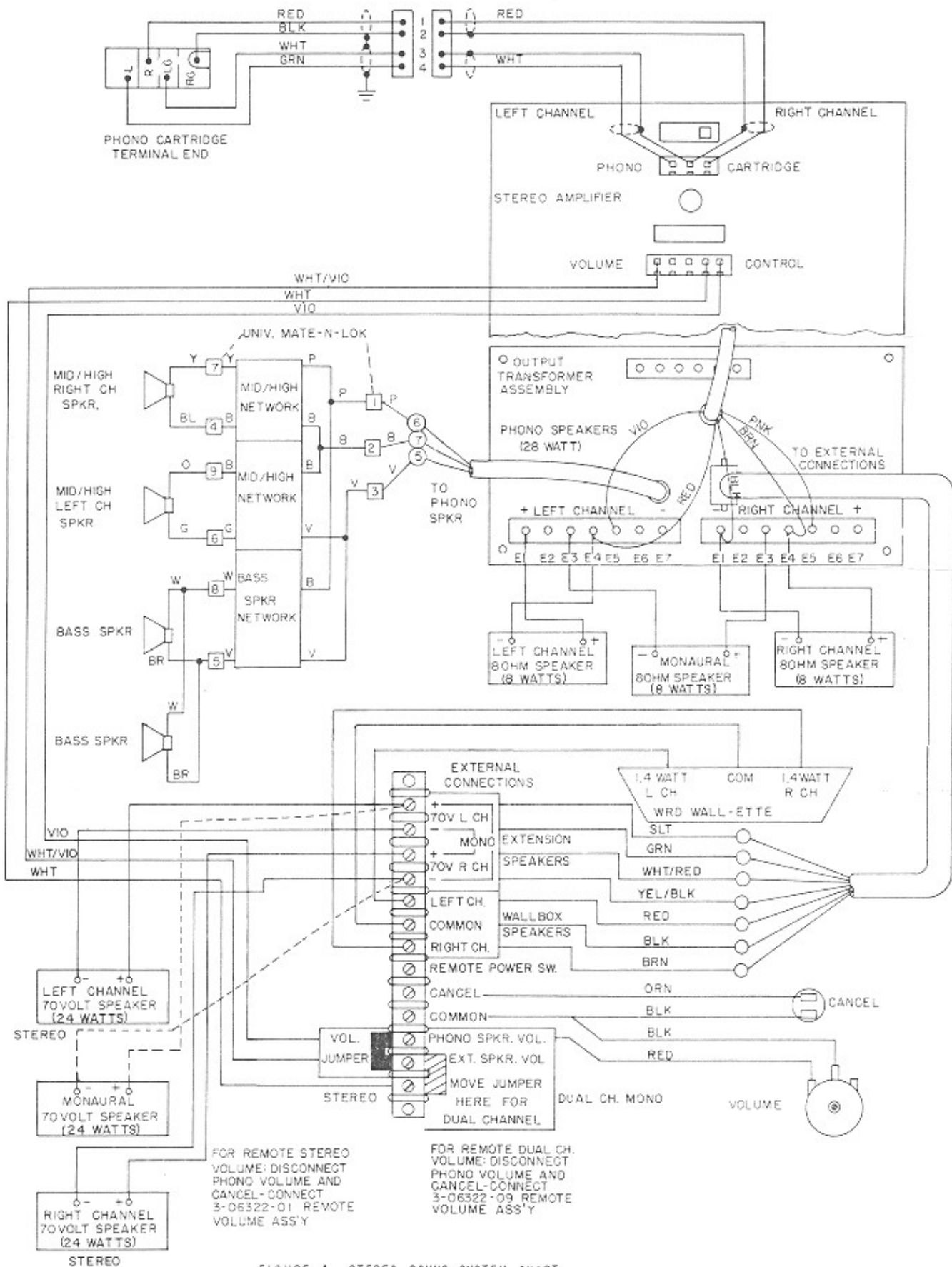

FIGURE 4 STEREO SOUND SYSTEM CHART  
FOR STEREO PHONOGRAPH, EXTENSION SPEAKERS & WALLETT SPEAKERS

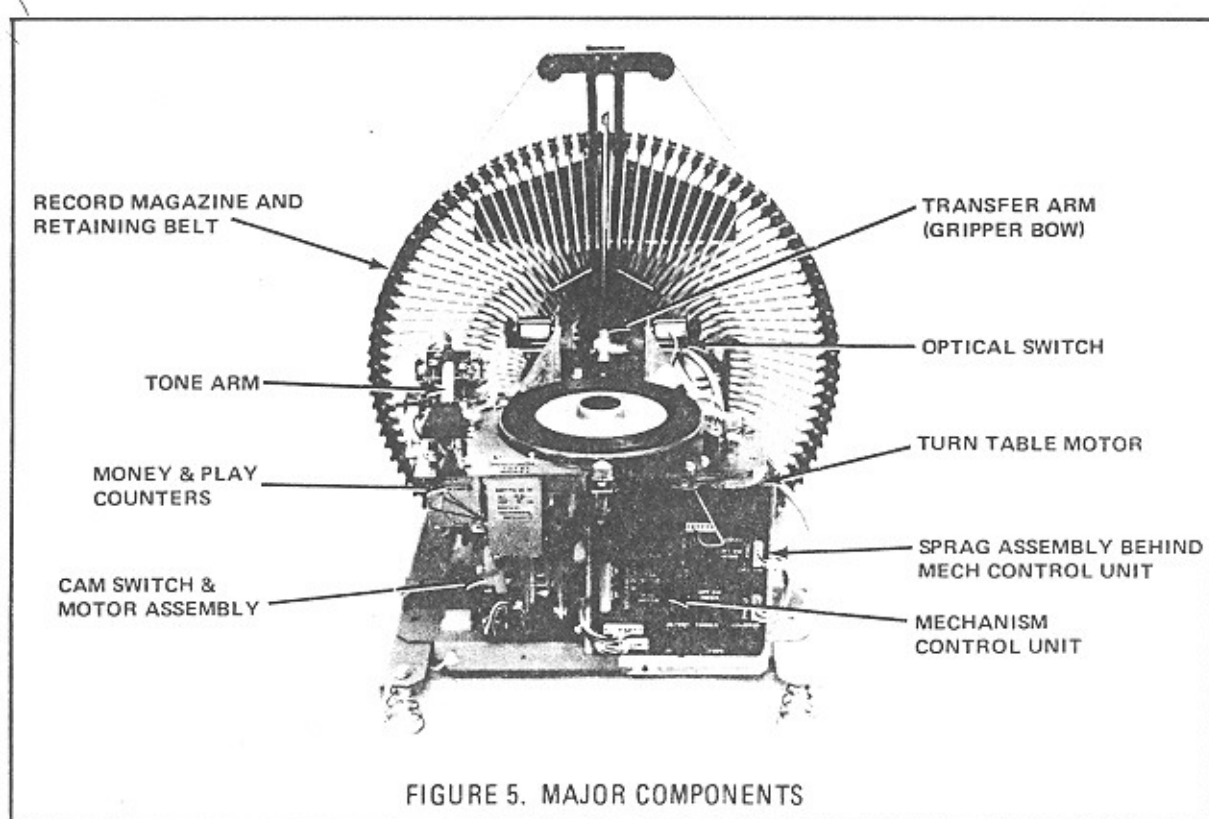

FIGURE 5. MAJOR COMPONENTS

## RECORD CHANGER MECHANISM

### INTRODUCTION

This section contains preventive maintenance procedures, including cleaning and lubrication instructions. A description of record changer operation is included along with complete adjustment instructions.

Cleaning and lubrication procedures should be performed at regular intervals specified, while adjustments should be made only when necessary.

### PREVENTIVE MAINTENANCE

#### Cleaning

In addition to cleaning the cabinet exterior each time the location is visited, clean the interior every three to six months, as required. Keeping the cabinet interior clean reduces dust, resulting in increased record and component life. Always clean the phonograph cabinet prior to lubrication.

1. Use a vacuum cleaner, if available to remove heavy dust deposits.

#### WARNING

**USE SOLVENTS IN A WELL-VENTILATED AREA ONLY: DO NOT USE SOLVENTS ON ANY TYPE OF PLASTIC PARTS.**

2. Use a clean, lint free cloth saturated in denatured alcohol to clean mechanical parts.

3. Clean electrical parts using a clean, dry cloth or camel's hair brush.

#### Five Year Lubrication

Your phonograph requires lubrication only after five years. To maintain smooth, trouble-free operation, lubricate the record changer mechanism as shown.

#### Do Not Over-Lubricate

Do Not Use Oil or Grease on Solenoid Plungers.

One drop 3:1  
electric motor oil

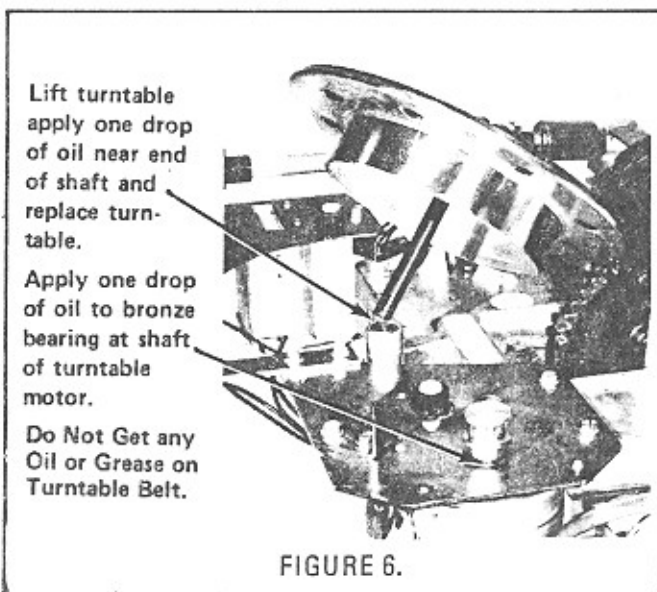

FIGURE 6.

## RECORD CHANGER MECHANISM OPERATION

The following paragraphs contain a brief explanation of the operation of the record mechanism. The mechanism holds 100 records and plays selections on command from the selection system. Identification and location of each major component is shown in figure 5. The purpose and description of each component is explained in the following text.

**Magazine, Belt and Transfer Arm.** The record magazine stores 100 7-inch 33 or 45 rpm records in a circular cage. A seamless belt around the cage keeps records in position. The rollers permit the transfer arm to clear the belt when removing and returning records to the magazine and also maintain belt tension.

**Play Counter.** The play counter is mounted to the left of the turntable and accumulates the total number of plays on the phonograph.

**Money Counter.** The Money Counter is mounted on the left side of the turntable and it registers the total money deposited in the phonograph.

**Optical Switch.** The Optical Switch is in front of the record magazine and straddles the magazine gear. There are two sensors in the switch. One sensor indicates when record "99" is in gripping position. This sensor is called the home sensor. The other sensor counts the number of gear teeth that pass by during scan to tell which record is in gripping position. This sensor is called the index sensor.

**Mechanism Control Unit.** This solid state switching unit controls the scan, transfer and toggle shift function.

**Sprag Assembly.** This assembly operates the record magazine in position. It is located at the center of the record changer mechanism, immediately in front of the record magazine and below the record transfer arm. The magazine motor rotates the record magazine. The solenoid operated sprag assembly locks the magazine in place.

**Tone Arm Assembly.** The tone arm assembly plays records after they are positioned on the turntable by the record transfer arm. The tone arm contains a stereo cartridge with a diamond stylus that is designed to track at three to four grams pressure. The stylus plugs into the cartridge for easy replacement. Four receptacles in the tone arm assembly mate with a plug to connect the cartridge to the pre-amplifier via 4-conductor shielded cable.

**Turntable Motor.** The turntable motor is a constant speed 300 RPM (at 60 Hz.) synchronous motor. The turntable is driven with a belt to obtain the proper turntable speed with minimum wow and flutter. For 50 Hz. locations, the motor pulley must be changed and a wiring change must be made on the motor terminal strip. (See Shop Manual.)

**Automix.** (Optional) Automix operation enables the phonograph to play both 33 and 45 RPM records in any order. Automix components consist of a speed shift coil, a hub shift coil and a trip wire and switch on the turntable hub.

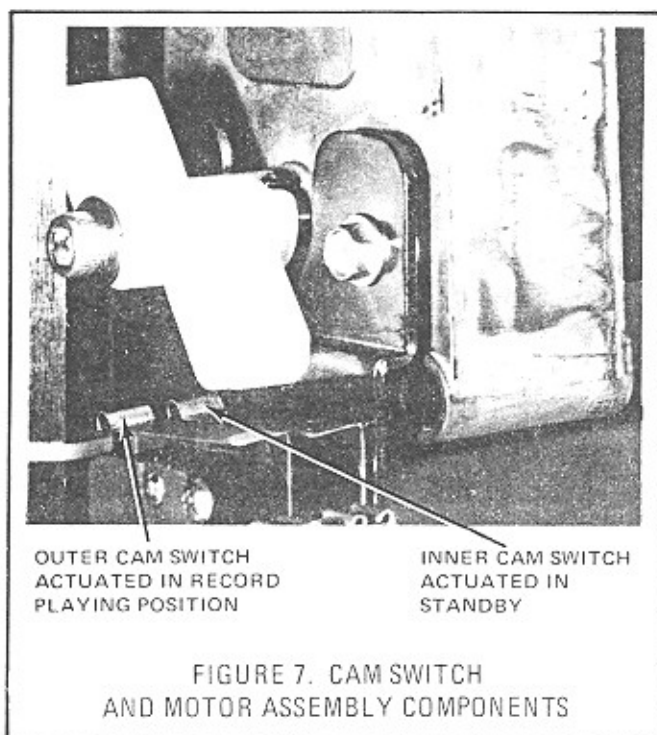

**Cam Switch and Motor Assembly.** (See Figure 7 ). The cam switch and motor assembly consists of the transfer motor, cam, and two cam switches. A nylon cam operates the cam switches.

## RECORD CHANGER ADJUSTMENTS

### I. SPRAG ASSEMBLY ADJUSTMENTS

The following steps must be used to make sprag assembly adjustments.

**WARNING**  
**TURN POWER OFF.**

1. Depress solenoid plunger until the roll pin bottoms on plunger stop. (Actuate by pressing on plunger.)

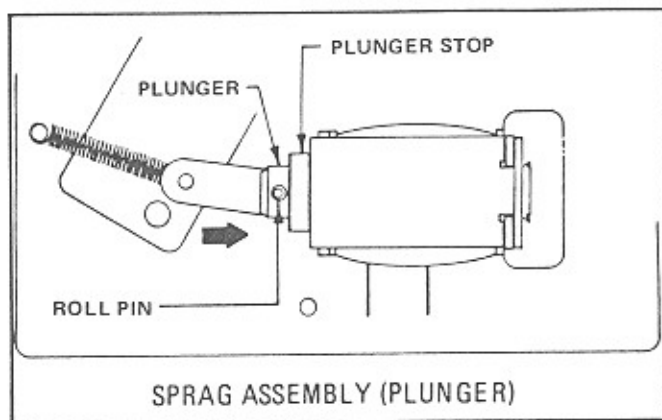

2. Rotate the record magazine and note the clearance between the sprag lever and the sprag wheel located on the backside of the sprag plate assembly. The sprag lever must not touch the sprag wheel and the clearance must not be greater than 1/32 inch. It will be necessary to remove the sprag assembly to make corrections, if required.

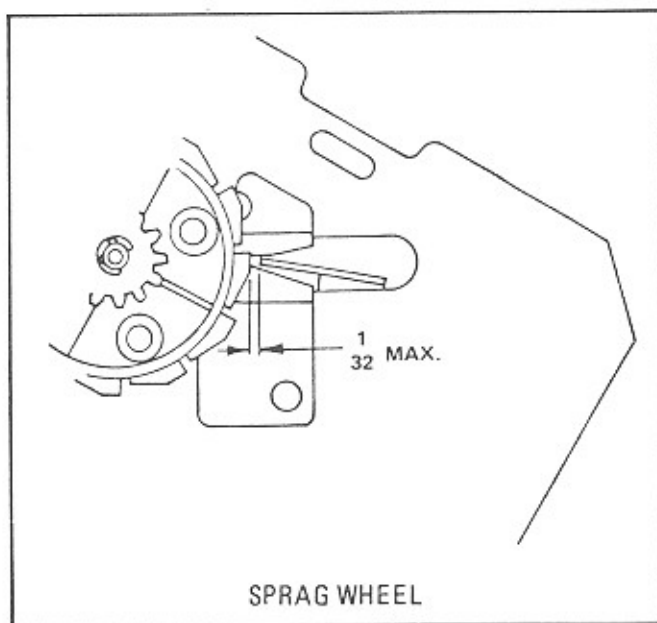

3. To remove sprag assembly, first remove new mech control board mounting plate (3 screws). Disconnect wires to the solenoid and motor, remove the three mounting screws and slide the assembly out of the right side of the mechanism.

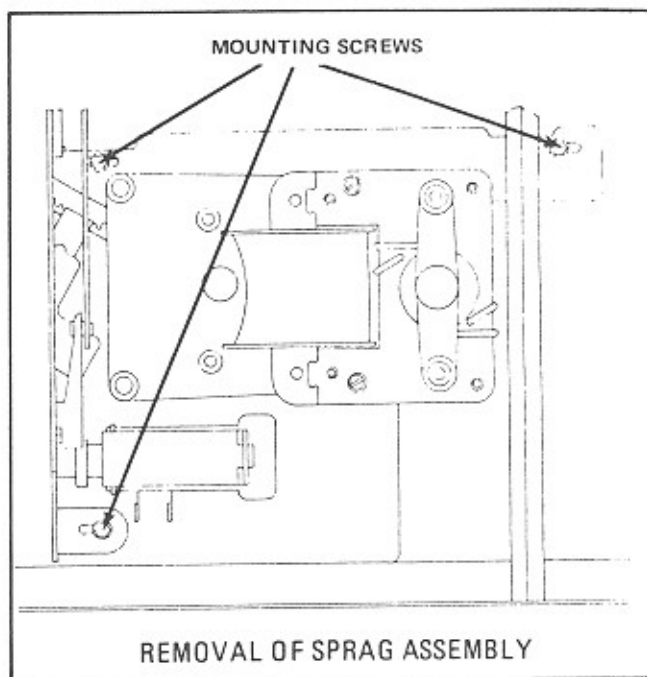

4. Loosen the solenoid mounting screws and with the roll pin against the plunger stop, position the solenoid so that there is a .015 to .025 inch gap between the sprag lever and the highest point on the sprag wheel.

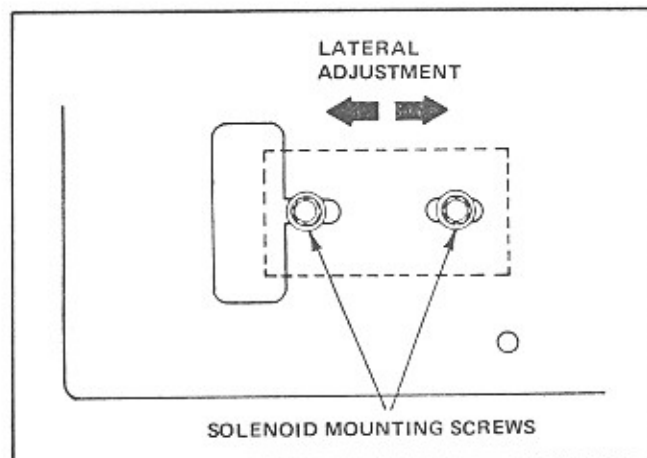

5. Tighten solenoid mounting screws.
6. Replace sprag assembly in mechanism with (3) mounting screws and replace black and white-blue wires to the solenoid and the yellow and yellow-black wires to the magazine motor.

See Section VI for instructions for aligning the record magazine and readjusting the optical switch.

## II. CAM SWITCH ADJUSTMENTS

If it is necessary to remove the switch cam from the transfer motor, the following procedure must be followed to ensure that the cam is properly located and not 180° out of position.

1. Locate the inner lobe so that it is pointing in the same direction as the crank. Turn cam so that neither cam lobe is on a switch before removing or installing cam. (See Figure 8)

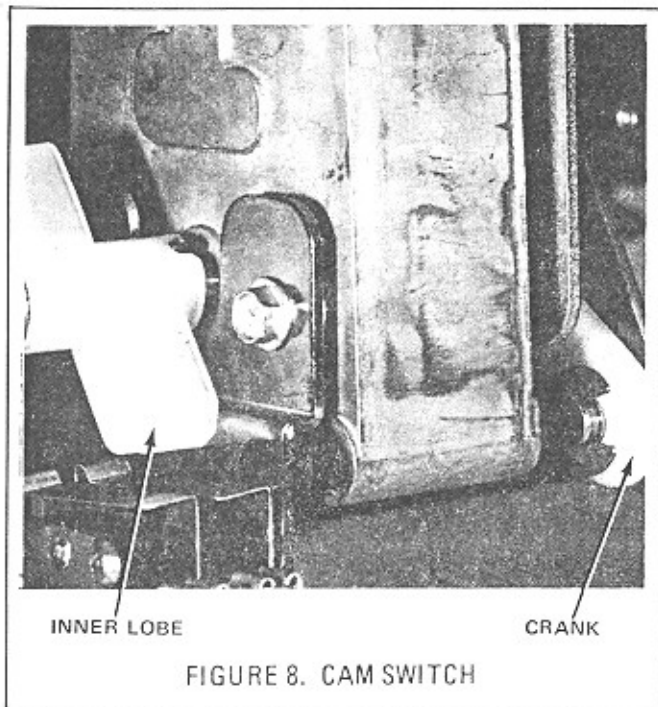

### Check and Adjust Cam Switch Operation

1. Check that the plastic cam leaf spring and switch plunger just touch as shown below.
2. To adjust switches, loosen mounting screw under plunger end and move switch housing as required.

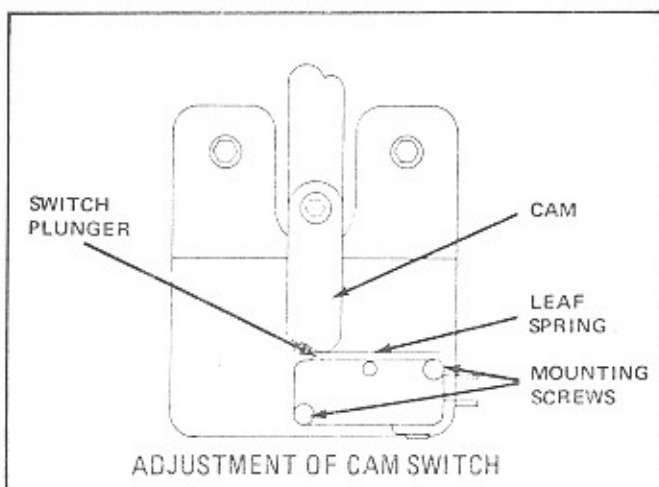

3. Tighten mounting screw and recheck operation.

## III. TONE ARM CAM ADJUSTMENTS

1. Lift tone arm and turn it clockwise so the pins are disengaged from the cam.
2. With gripper bow in scan position over magazine (transfer motor crank in maximum down position) loosen one Allen head set screw in collar.
3. Using a 5/32 inch Allen wrench in end of transfer motor shaft, turn motor shaft clockwise until gripper bow is in playing position (transfer motor crank arm in maximum up position).
4. Loosen the other Allen head set screw in collar.
5. Position tone arm cam so that the outside diameter of the tone arm lifting pin is in line with the edge of the slot in the cam, as shown below.

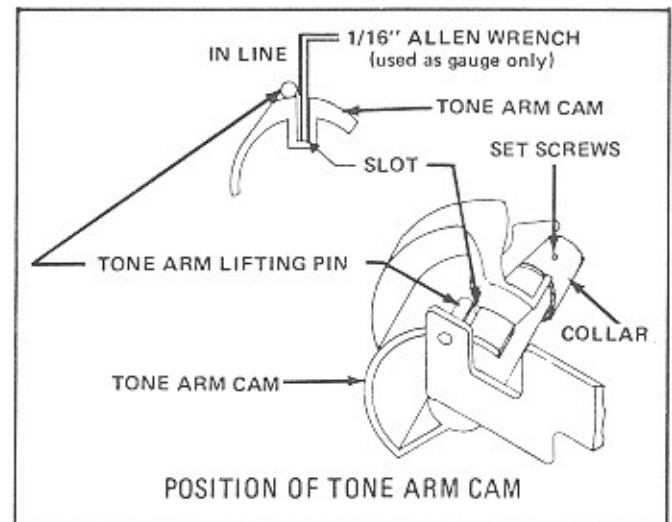

6. Tighten Allen head set screws and replace tone arm.

## IV. RECORD MAGAZINE TRANSFER ARM SUPPORT ADJUSTMENT

Eliminate Magazine End Play and Center Transfer Arm Support.

1. Loosen set screws in rear Magazine Shaft collar. Push collar on to Magazine Shaft to eliminate end play and tighten screws.
2. Loosen screw that holds transfer arm support to mechanism frame.
3. Adjust transfer arm support so transfer arm is centered in opening.
4. Tighten mechanism frame to transfer arm support screw.

## V. MAGAZINE BELT ADJUSTMENT

1. Loosen two adjustment screws shown.

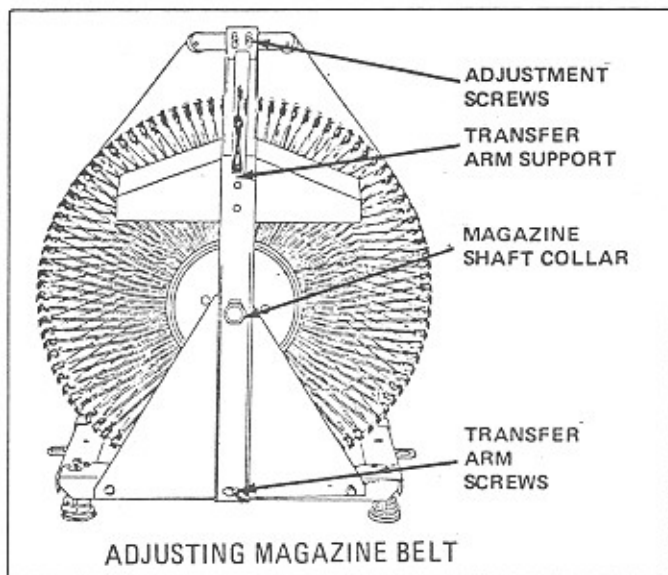

2. Raise bracket to tighten belt around magazine.
3. Check that belt rides evenly in center of belt guides, all the way around the magazine.
4. Tighten 2 adjustment screws.

## VI. ALIGNING MAGAZINE STOPPING POSITION WITH TRANSFER ARM.

1. For this adjustment use a record in good condition without warp or dish. Place this record in any position in the record magazine and rotate the magazine until this record is in the top position. Allow magazine sprag lever to engage and lock magazine in this position.

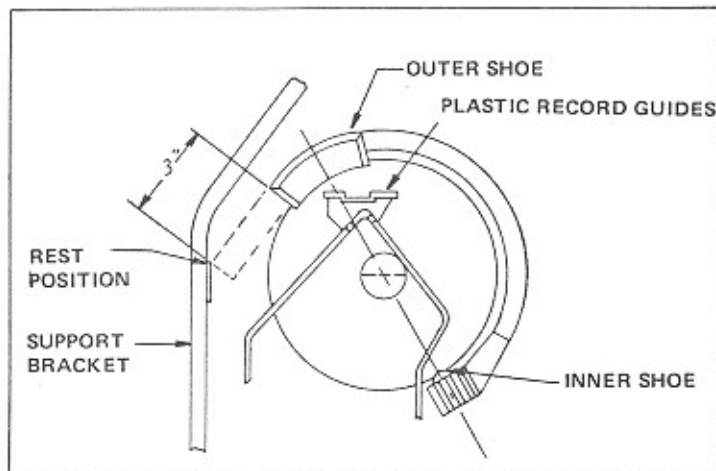

2. Using a 5/32 inch allen wrench in end of transfer motor shaft, turn motor shaft clockwise until gripper bow lifts record out of magazine, and outer shoe is approximately 3 inches from its rest position on the back support.

In this position a center line from the inner shoe thru the center of the outer shoe will pass thru the back of the plastic record guide on the magazine.

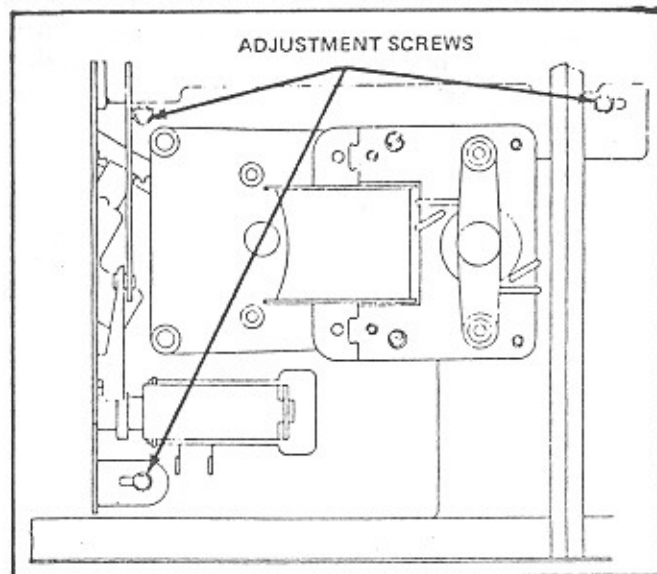

3. With the record and gripper bow in this lifted position rock the magazine to the left and right and make sure the plastic magazine record guides do not come in contact with the record on either side.

If the guide makes contact with the record on one side or magazine space does not center with the record the following adjustment to the magazine will be necessary.

4. Loosen three screws in magazine motor mounting plate.
5. With sprag wheel locked, move magazine until record is centered between belt guides. (Adjusted screws will be approximately centered in slots).
6. Tighten three screws in magazine motor mounting plate securely.
7. Whenever the record magazine is adjusted, the optical switch must be adjusted as shown in the following adjustment procedure.

## VII. OPTICAL SWITCH ADJUSTMENTS

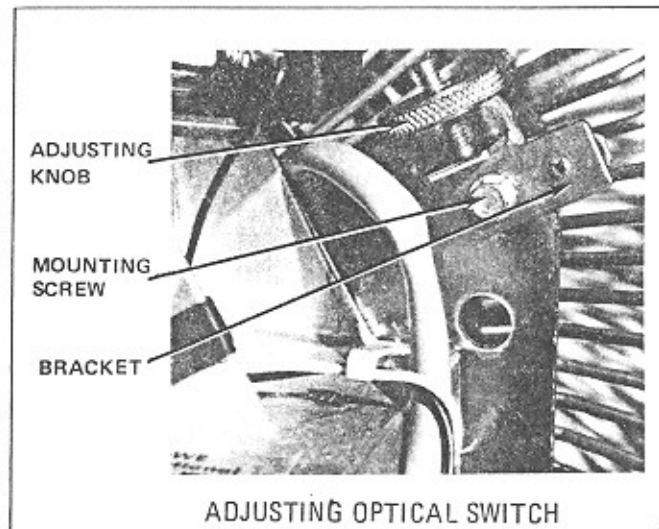

1. Release magazine sprag lever from sprag wheel and rotate record magazine until selection 99 is at the top center. Engage the sprag lever locking the magazine in place.



2. Loosen optical switch bracket mounting screw, turn adjusting knob counter clockwise to top of its' travel, and move bracket to the most downward position. Snug optical switch bracket mounting screw (do not tighten).
3. Rotate record magazine counterclockwise to remove gear backlash, hold in this position.
4. Turn adjusting knob clockwise, moving the bracket upward and watch both the index and home lamps on the mechanism control unit.
5. When both lamps light, continue to move the bracket past this position until the index lamp JUST goes out. The home lamp will stay on. Tighten the mounting screw.
6. With the sprag lever engaged rotate the record magazine clockwise and counter-clockwise by hand taking up gear backlash in both directions. The index lamp should stay off, and the home lamp should stay on.
7. Release magazine sprag lever from the sprag wheel and rotate record magazine to several other positions repeating step six. The index lamp should stay off. The home lamp will not be on.

### VIII. TONE ARM ADJUSTMENTS

#### 1. Adjust Vertical Pivot

- a. Adjust tone arm pivot screw so that tone arm pivot is loose enough to move free vertically or a distance of two inches above turntable.
- b. Check that tone arm moves less than 1/32 inch from side to side at stylus.

#### 2. Set Stylus Force.

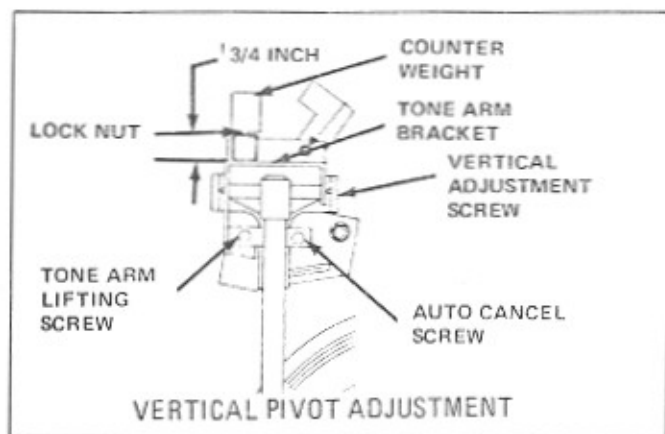

- a. The distance between the counter weight and the tone arm bracket should be 3/4 inch for 3-1/2 grams stylus force.
- b. If distance is not correct loosen lock nut, adjust counter weight and tighten lock nut.

#### 3. Set Stylus Clearance.

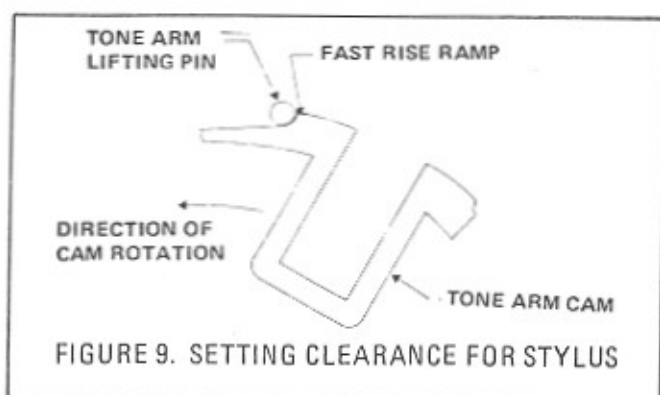

Using a 5/32 inch allen wrench in the end of the transfer motor shaft, turn motor shaft clockwise until gripper bow has placed a record on the turntable. Push down on the tone arm lifting pin (See Figure 9) and continue to turn motor shaft to swing tone arm into the set down position. You will be able to feel the fast rise ramp of the cam contact the tone arm pin. At this point, release the pressure on the lifting pin and adjust the tone arm lifting screw so that the stylus just touches the record.

#### 4. Set Stylus Height.

- a. Operate transfer assembly to position tone arm over turntable rim.

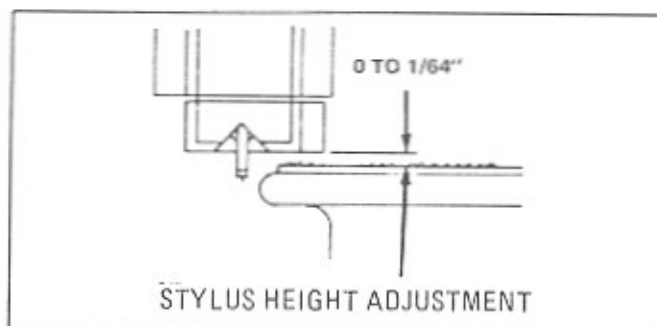

- b. Turn auto cancel screw until stylus holder is flush to 1/64 above turntable pad surface with tone arm in play position.

#### 5. Set Stylus Setdown Position and Tone Arm Cutoff Switch.

- a. Place undersize (6-25/32 inch diameter) record on turntable.

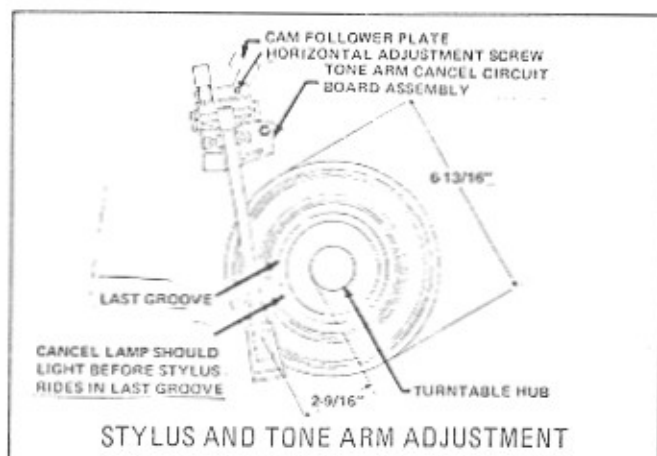

- b. Operate transfer assembly to bring tone arm to play position.
  - c. Loosen horizontal adjustment screw.
  - d. While holding cam follower plate against tone arm cam, move tone arm, as required, until stylus is 2-9/16 inches from the edge of the turntable hub.
  - e. Tighten horizontal adjustment screw and check adjustment.
6. Adjust Tone Arm Cutoff Switch
- a. Disconnect microcomputer harness from mechanism control board (19 pin connector). (To prevent mechanism from cancelling.)
  - b. Loosen mounting screw on tone arm cancel circuit board assembly.
  - c. Position tone arm cancel circuit board assembly, as required, until reed switch is closed, as indicated by cancel lamp in mechanism control unit. This should happen before stylus enters "closed" record groove.

#### BELT GUIDE ADJUSTMENT

1. Loosen nut that fastens belt guide.
2. Adjust as shown below.
3. Tighten nut.

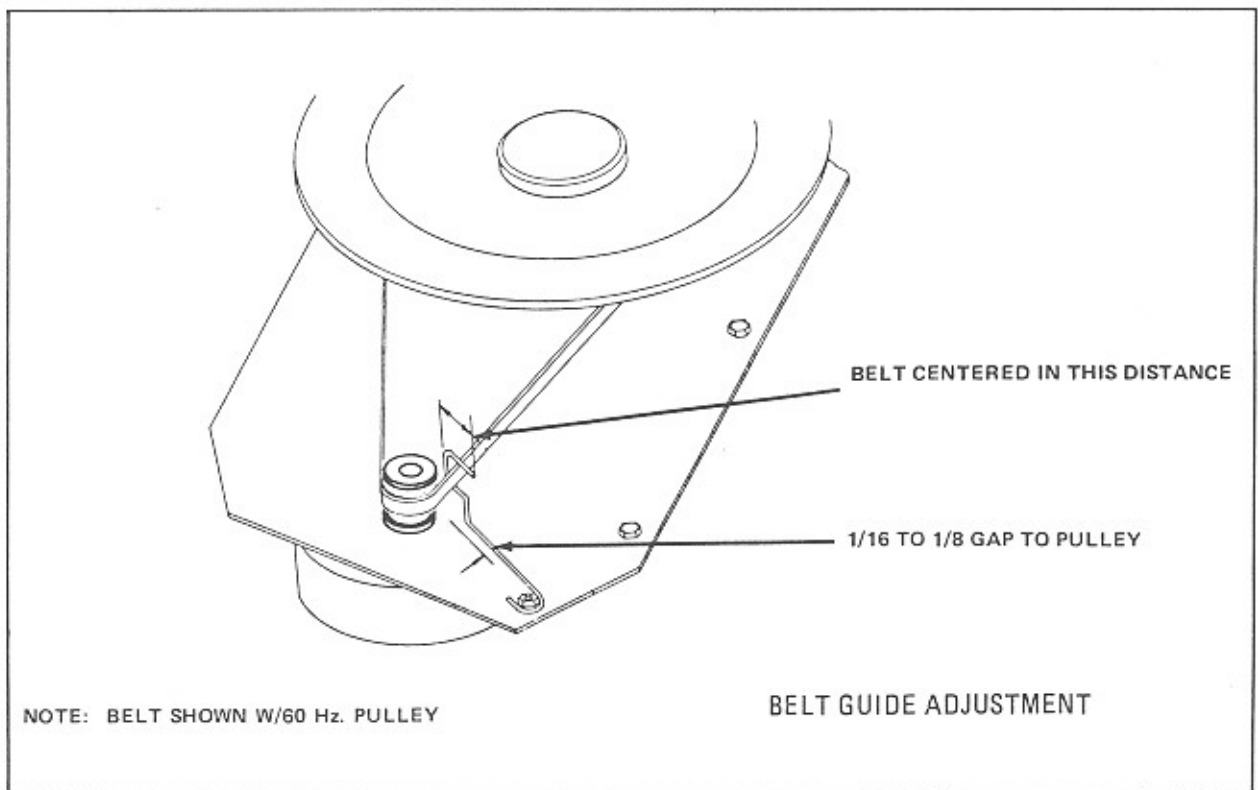

## COIN SWITCH ADJUSTMENTS

### OPERATION CHECK

1. Hold plastic coin switch lever in normal position and drop a coin through slug rejector.
2. When the coin comes to rest on the lever, release the lever slowly.
3. Check that the weight of the coin operates the lever enough to close the coin switch and allow the coin to fall free.
4. Repeat steps 1, 2 and 3 for other three levers.

### CONTACT PRESSURE AND GAP

1. Check that each moving switch blade pushes against its lever with 7 to 8 grams force to hold lever against cushion. To adjust pressure, bend the blade near its mounting point.
2. Check that each non-moving blade pushes against its stiffener blade with 8 to 15 grams force. To adjust pressure, bend the contact blade near its mounting point.
3. Check that contact gap at switch with short double paddle is 0.030 to 0.035". Check that contact gap for long paddle switches is 0.040 to 0.045 inch.

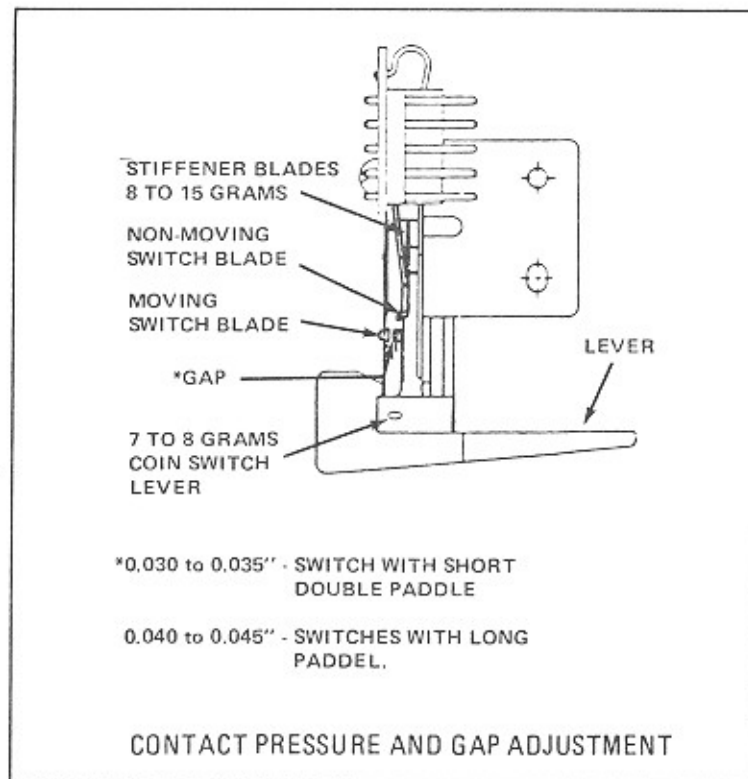

COIN ACCEPTORS  
3 COIN

FRONT VIEW

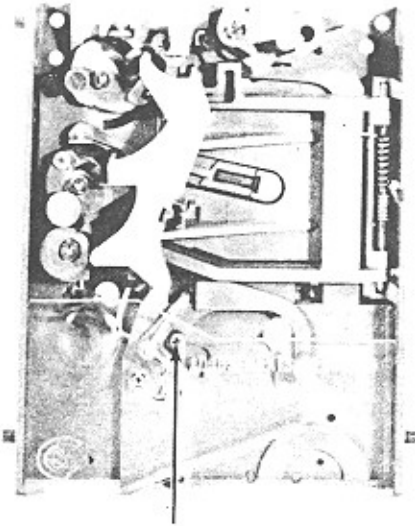

REMOVE COVER AND DRIVE  
No. 6-32 SCREW INTO BOSS AS  
SHOWN TO REJECT NICKELS

BACK VIEW

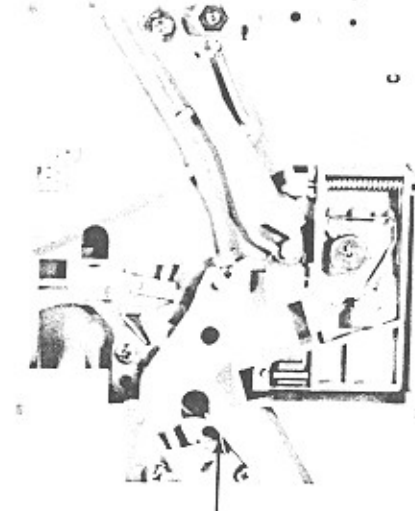

TO REJECT DIMES ADD COINCO  
No. 903-915 BLOCK OUT WIRE

COIN ACCEPTORS  
4 COIN

LINE UP EDGE OF  
DEFLECTOR WITH  
THIS LINE

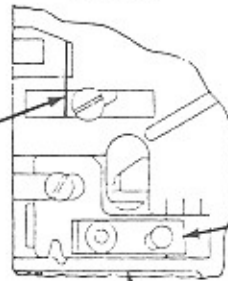

TO IMPROVE S SLUG REJECTION  
ADJUST AS SHOWN

LINE SEPARATOR AS SHOWN

FRONT VIEW

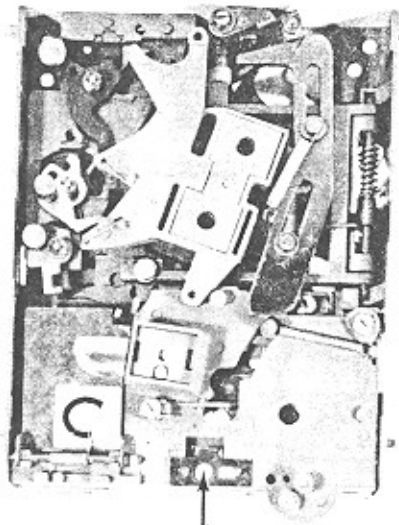

MOVE THIS BRACKET TO RIGHT  
TO REJECT NICKELS (OR JUST  
FAR ENOUGH TO LEFT TO  
ACCEPT NICKELS)

BACK VIEW

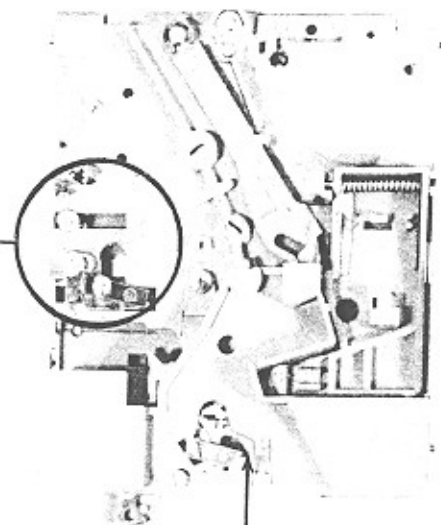

TO REJECT DIMES ADD COINCO  
No. 903915 BLOCK OUT WIRE

COIN SWITCH WIRING

4 COIN - COINCO

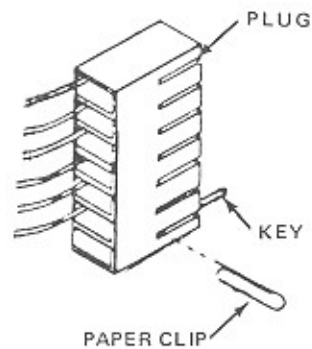
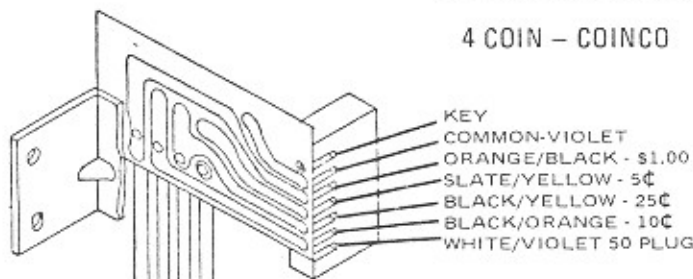

2-14114-01  
SPACER FOR  
COINCO 4  
COIN ONLY  
(REMOVE FOR 3 COIN)

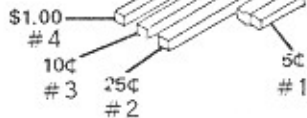

R-85

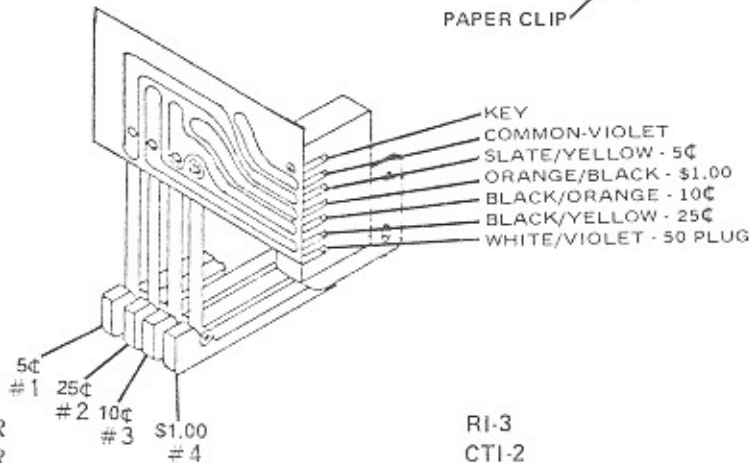

RI-3  
CTI-2

NOTE

SWITCH W/V AND O/B WIRES DEPENDING ON 50¢ OR \$ COIN. SWITCH WIRE COLORS AS REQUIRED FOR OTHER REJECTORS. MAINTAIN COLOR - VS - COIN VALUE.

\*MM = MONEY METER COUNTER RATIO

WIRING FOR 4 COIN (.05, .10, .25, .50)

COUNTRY	COIN DENOMINATION TO ACTUATE SWITCH								
	SWITCH #1	WIRE COLOR	SWITCH #2	WIRE COLOR	SWITCH #3	WIRE COLOR	SWITCH #4	WIRE COLOR	M M *
AUSTRALIA					10¢	B/O	20¢	B/Y	1
AUSTRIA			ES	W/V	1S	B/O	10S	O/B	10
BELGIUM			25¢	B/O	10¢	S/Y	5Fr.	S/Y	100
COLUMBIA			20¢	S/Y	1 PESO	B/Y	2 PESO	W/V	4
DENMARK			1 Kr.	B/O			5 Kr.	W/V	10
ECUADOR			1Sc.	B/O					10
EL SALVADOR			5¢	S/Y	25¢	B/Y	10¢	B/O	1
ENGLAND			10P	B/O			50P	W/V	100
FINLAND			1 Mk.	B/O			50P	W/V	10
FRANCE			1 Fr.	B/O			5 Fr.	W/V	10
GERMANY			1 MK	B/O	50 Pfg.	S/Y	2 MK	B/Y	10
HOLLAND			25¢	B/Y			1 G	O/B	1
HONDURAS			50¢	B/Y	20¢	B/O	10¢	S/Y	2
ITALY			50 L.	S/Y			100 L.	B/Y	1,000
NICARAGUA			50¢	W/Y	25¢	B/Y	1 COR	O/B	1
NOR.-SWED.			1 Kr.	B/O			5 Kr.	W/V	10
SPAIN			5 PTAS	S/Y			25 PTAS	B/Y	100
SWISS			1 Fr.	B/O	50 Rp	S/Y	2 Fr.	B/Y	10
U.S.	5¢	S/Y	25¢	B/Y	10¢	B/O	\$1	O/B	1
VENEZUELA	1 REAL	B/O	1 BOLIVAR	B/Y	1 MEDIO	S/Y	2 BOLIVAR	W/V	4