

NO VISE? NO PROBLEM WITH THIS NEW JIG

I Can Do That:
Storage Bench



POPULAR WOODWORKING

Learn How. Discover Why. Build Better.

APRIL 2009 #175

**Ultimate Bungalow
Medicine Cabinet**

**3 Ways to Make
Tighter Edge Joints**

**2 New Saws Try
To Derail Festool**

**Quick & Easy
Band Sawn
Jewelry Box**

**Essential &
Ingenious
Grinder Jig**



popularwoodworking.com



POPULAR Woodworking

Learn How. Discover Why. Build Better.

— APRIL 2009 —

FEATURES



34



44



55

34 Greene & Greene Medicine Cabinet

Humble origins (a garage) and an unparalleled pedigree (Charles and Henry Greene) combine to make this a stunning project.

BY ROBERT W. LANG

40 Three Ways to Make Edge Joints

Without edge joints, we'd have no wide panels. So what's the best way to make this bewildering but imperative joint? We show you three solid (but different) methods.

BY ROBERT W. LANG,
GLEN D. HUEY &
CHRISTOPHER SCHWARZ

44 Providence Writing Desk

This compact, elegant desk features a delicate bead that wraps the bottom of the apron, which is echoed at the ankles of the saber-shaped legs.

BY MARIO RODRIGUEZ

50 Plunge-cut Saws

With three plunge-cut saws on the U.S. market (two of them are new), how do you know which one is the best? We put all of them through their paces, and share the results.

BY GLEN D. HUEY

55 Carving Spanish Feet

A Delaware Valley foot and a Pennsylvania ring-and-vase turning are combined to develop a period-style design.

BY CHARLES BENDER

58 Band-sawn 'Twister' Box

This undulating band-sawn box is simple and fun to make, and it makes a great gift.

BY DAVID THIEL, JIM STACK &
LOIS KEENER VENTURA

62 Grinder Tool Rest Jig

This simple jig makes it easy to set your tool rest at predictable, repeatable angles.

BY BRUCE D. WEDLOCK



58

Number 175, April 2009. Popular Woodworking (ISSN 0884-8823, USPS 752-250) is published 7 times a year in February, April, June, August, October, November and December by F+W Media, Inc. Editorial and advertising offices are located at 4700 E. Galbraith Road, Cincinnati, Ohio 45236; tel: 513-531-2222. Unsolicited manuscripts, photographs and artwork should include ample postage on a self-addressed, stamped envelope (SASE); otherwise they will not be returned. Subscription rates: A year's subscription (7 issues) is \$19.96; outside of the U.S. add \$7/year • Canada Publications Mail Agreement No. 40025316. Canadian return address: 2835 Kew Drive, Windsor, ON N8T 3B7 • Copyright 2009 by Popular Woodworking. Periodicals postage paid at Cincinnati, Ohio, and additional mailing offices. Postmaster: Send all address changes to Popular Woodworking, P.O. Box 420235, Palm Coast, FL 32142-0235 Canada GST Reg. # R122594716 • Produced and printed in the U.S.A.



12 Are We Friend or Foe to the Trees?
OUT ON A LIMB
BY CHRISTOPHER SCHWARZ

14 Firmer Chisels
LETTERS
FROM OUR READERS

16 Vise-clamping Odd Shapes
TRICKS OF THE TRADE
FROM OUR READERS

20 A Sticky Situation
THE WOOD WHISPERER
BY MARC SPAGNUOLO

22 Hold Handwork Without a Vise
JIG JOURNAL
BY ROBERT W. LANG

24 Shaping the Splat
ARTS & MYSTERIES
BY ADAM CHERUBINI

28 Storage Bench
I CAN DO THAT
BY DREW DEPENNING

30 Veritas Dovetail Saw
TOOL TEST
BY OUR STAFF

66 Finishing the 5 Types of Wood
FLEXNER ON FINISHING
BY BOB FLEXNER

72 The Allure of the New
OUT OF THE WOODWORK
BY DOUG FULKERSON

ON THE APRIL COVER



This cabinet speaks to the Greene brothers' obsessive attention to detail; the original is in the chauffeur's garage bathroom at the Gamble house. Page 34.

COVER PHOTO BY AL PARRISH



APRIL 2009

ONLINE



New This Month

Learning Curves

In this issue, the three senior editors discuss their preferred methods for making the all-important edge joint. Editor Christopher Schwarz uses (natch) planes in his methods, so we've posted a complementary story by David Charlesworth (from the August 2005 issue, #149) on using curved plane irons to produce flat boards.

popularwoodworking.com/apr09

Video Gallery

Choose and Use the Right Glue for Veneering

In this issue, Marc Spagnuolo (a.k.a. The Wood Whisperer) writes about six common situations where specialty glues are needed. In his accompanying video, he shows you how to select, mix and use the best glue for veneer.

popularwoodworking.com/apr09

Make the Most of Eight Years of Our Magazine

We've collected all the issues of *Popular Woodworking* from 2000-2007 on one CD – with a plethora of added features. And now we've made a short video that shows you how to make the most of all the special features, in-depth searches and more.

popwood.com/cdvideo



Project Plans

SketchUp Collection

A couple years ago, our resident draughtsman (Senior Editor Robert W. Lang) began designing 3D models of projects in SketchUp (a free program from Google). And recently, we invited readers to submit models of projects from our pages. The response has been tremendous – thank you. Now, we've created a new web page that discusses the program, and how it's changed the way we approach and think about furniture design. And of course, we've included links to all our free SketchUp models. popularwoodworking.com/sketchup

Greene & Greene Medicine Cabinet

The Gamble house medicine cabinet (on page 34 of this issue) features curved profiles on the cabinet sides. For full-sized patterns of the curve (and a 3D SketchUp model), go to: popularwoodworking.com/apr09

And More!

Visit popularwoodworking.com/apr09 to find a complete list of all the online resources for this issue – including videos, additional drawings and photos.

popularwoodworking.com

- [Contact Customer Service](http://popularwoodworking.com/magazines)
- [Free Project Plans](http://popularwoodworking.com/projects)
- [Article Index](http://popularwoodworking.com/articleindex)
- [Tool Reviews](http://popularwoodworking.com/tools)
- [Editor Blogs](http://popularwoodworking.com/blogs)
- [Writer's Guidelines](http://popularwoodworking.com/writersguidelines)
- [Contact the Staff](http://popularwoodworking.com/contactus)

CONTRIBUTORS

Charles Bender began wood-
working at the age of 12. In his teens he
studied under a German Master at his
local vocational technical school who
taught him the value and proper use of
hand tools. For more than 30 years he's
honed his skills creating masterpieces for
clients throughout the country.

Since completing his apprenticeship
and starting his own period-furniture
business in 1991, Charles has been rec-
ognized as one of America's top tradi-
tional craftsmen. His work is in private
collections, museums and at some of the
best juried craft shows in the country. In
his first story for *Popular Woodworking*, he
carves Spanish feet (page 55).



In 2007, Charles added the title of
"woodworking mentor" to his résumé
and started the Acanthus Workshop
(acanthus.com), a school for fine crafts-
manship.

Doug Fulkerson says woodwork-
ing has been in his blood (or perhaps his
blood has been on wood) ever since as
a farm boy in Hart County, Ky., he got
his first splinter from a tobacco stick. He
and his father watched "The New Yankee
Workshop" and "The Woodwright's
Shop" just about every weekend.

But Doug didn't seriously start putting
tools to wood until about 1994 when in
graduate school working on a history
degree, he came across a book called "The
Traditional Bowyer's Bible, vol. I." He was
hooked immediately on making wooden
bows and arrows, from English longbows
to Native American flat bows using just
hand tools. At his wedding, Doug gave



his groomsmen Cherokee hunting bows
and arrows he made from red oak har-
vested from his father's farm.

Doug wrote the "Out of the Wood-
work" column in this issue, on page 72.

Lois Keener Ventura has been
woodworking most of her life. She
designed, sculpted and exhibited band-
sawn boxes and other woodworks profes-
sionally for more than a decade. During
that time, she earned several awards and
invitations to juried shows, and collectors
worldwide own her work.

Medical issues have curtailed Lois'
full-time woodworking, but she still

takes on occasional woodcraft challenges
both in and out of the shop. She recently
worked with Popular Woodworking
Books editors to create "Sculpted Band
Saw Boxes"; Lois designed the nine boxes
built by the editors, and 32 examples of
her own work serve as additional visual
inspiration. "Twister," built by former
Senior Editor David Thiel, begins on
page 58 of this issue.

POPULAR Woodworking®

Learn How. Discover Why. Build Better.

APRIL 2009, VOL. 29, NO. 2

popularwoodworking.com

EDITORIAL OFFICES 513-531-2690

PUBLISHER & GROUP EDITORIAL DIRECTOR

Steve Shanesy

EDITOR Christopher Schwarz

x11407 ■ chris.schwarz@fwmedia.com

ART DIRECTOR Linda Watts

x11396 ■ linda.watts@fwmedia.com

SENIOR EDITOR Robert W. Lang

x11327 ■ robert.lang@fwmedia.com

SENIOR EDITOR Glen D. Huey

x11293 ■ glen.huey@fwmedia.com

MANAGING EDITOR Megan Fitzpatrick

x11348 ■ megan.fitzpatrick@fwmedia.com

ASSOCIATE EDITOR FOR THE WEB Drew DePenning

x11008 ■ drew.depensing@fwmedia.com

PHOTOGRAPHER Al Parrish

CONTRIBUTING EDITORS

Adam Cherubini, Bob Flexner, Troy Sexton

F+W MEDIA, INC.

CHAIRMAN & CEO David Nussbaum

CFO James Ogle

PRESIDENT Sara E. Domville

SENIOR VP, MANUFACTURING & PRODUCTION Phil Graham

VP, MANUFACTURING Barbara Ann Schmitz

EXECUTIVE VP, eMEDIA John Lerner

VICE PRESIDENT IT, CIO Mike Kuehn

VP, CONSUMER MARKETING Sara DeCarlo

CONFERENCE DIRECTOR Sara Dumford

CIRCULATION DIRECTOR Linda Engel

NEWSSTAND DIRECTOR Susan Rose

PRODUCTION COORDINATOR Vicki Whitford

ADVERTISING

ADVERTISING DIRECTOR Don Schroder

331 N. Arch St., Allentown, PA 18104

TEL. 610-821-4425; FAX 610-821-7884

d.schroder@verizon.net

DISPLAY & CLASSIFIED ADVERTISING

SALES COORDINATOR

Krista Morel

TEL. 513-531-2690 x11311

krista.morel@fwmedia.com

SUBSCRIPTION SERVICES: Subscription inquiries, orders
and address changes can be made at popularwoodworking.com
(click on "Customer Service"). Or by mail: *Popular Woodworking*,
P.O. Box 420235, Palm Coast, FL 32142-0235. Or call 386-246-
3369. Include your address with all inquiries. Allow 6 to 8 weeks
for delivery.

NEWSSTAND DISTRIBUTION: Curtis Circulation Co.,
730 River Road, New Milford, NJ 07646

ATTENTION RETAILERS: To carry *Popular Woodworking* in
your store, call 800-894-4656 or write Magazine Retail Sales,
P.O. Box 5014, Iola, WI 54945-5014.

BACK ISSUES are available. Call 800-258-0929 for pricing or
visit popularwoodworking.com. Send check or money order to:
Popular Woodworking Back Issues, F+W Media Products, 700
E. State St., Iola, WI 54990. Please specify publication, month
and year.

Copyright ©2009 by F+W Media, Inc. All rights
reserved. *Popular Woodworking* is a registered
trademark of F+W Media.



Are We Friend or Foe To the Trees?

Sometimes when I'm on a walk with my children, they'll look up into the leafy branches and ask: "What kind of tree is that?" To which I'll reply: "Beats me. Let's cut it down and find out."

After a tree has been felled I can show you the difference between red oak and white, beech and birch, soft maple and hard. But when the tree is thriving and shrouded in green, I struggle to tell the difference between a willow and a walnut.

Like me, most woodworkers have an odd relationship with the society of trees. On the one hand, we are their ultimate destroyer. We prize the carcasses of the oldest trees with the straightest and widest trunks that are unmo- lested by disease, insects or barbed wire.

We pay exorbitant sums for the finest boards. In fact, I have seen how old-growth Appalachian forests are robbed by poachers with helicopters and chainsaws. This fact gives me pause every time my hands pass over a 16"-wide board at the lumberyard.

Yet, it is the things we build that forge a deep human affection for wood. Less than 200 years ago, nearly every object was built from wood—every house, every dining table and every piece of treenware on the table.

And for me it was the amazing wooden objects built by human hands that first sparked my fascination with trees and my desire to learn how they function and grow. The grain, color and warmth of the wood caused me to study up on cambium, extra- tives and tracheids.

So I was speechless at first when my youngest child insisted that I should be worried about "saving the trees."

At first I tried to explain to her that if we didn't build things out of wood, we would have to use other raw materials that aren't as renewable, such as metal, glass or petroleum-based plastics. She eyed me suspiciously because we recycle metal, glass and plastic in our house.

And then it came to me. When it comes to trees, woodworkers should be the creator, the preserver and the destroyer. As a destroyer, we slay the trees and cut their trunks into furniture-sized chunks. As preservers, the things we build with wood can last far beyond the lifetime of the maker or the tree. And

these objects can inspire in others the love for the material and the living tree.

Finally, if we are good woodworkers, we are also the creators. We should plant trees to replace the ones we harvest.

And that was my most sincere desire last spring. On the day that I finished building a wall cabinet for my youngest, we planted two dogwoods in our back yard. The smile on my face lasted all day—until the lawn service showed up that afternoon and turned the two saplings to mulch.

Like I said, it's an odd relationship we have with the trees. Perhaps some day I'll get it right. **PW**



PHOTO COURTESY OF cabincreekcds.com

POPULAR
Woodworking®
Learn How. Discover Why. Build Better.

Customer Service

How can I contact customer service with questions regarding my subscription, including a lost or damaged issue?

Visit popularwoodworking.com/magazines. Or write to *Popular Woodworking*, P.O. Box 420235, Palm Coast, FL 32142-0235. Or, if you prefer the telephone, call toll-free 877-860-9140 and a customer service representative will be happy to help you.

When does my subscription expire?

The date of your subscription expiration appears on your magazine mailing label, above your name. The date indicates the last issue in your subscription.

Can I get back issues of Popular Woodworking?

Back issues are available while supplies last. Visit popularwoodworking.com/backissues. Or if you know the exact month and year of the issue you want, call our customer service department toll-free at 800-258-0929 to order.

What if I want more information about the projects and tools I read about in Popular Woodworking?

For all editorial questions, please write to *Popular Woodworking* Editorial, 4700 E. Galbraith Road, Cincinnati, OH 45236. Or e-mail popwood@fwmedia.com.

Does Popular Woodworking offer group discounts?

Group discounts are available by special arrangement with the publisher. For more details, send an e-mail to debbie.paolello@fwmedia.com or call 513-531-2690 x11296.

Our Privacy Promise to You

We make portions of our customer list available to carefully screened companies that offer products and services we believe you may enjoy. If you do not want to receive offers and/or information, please let us know by contacting us at:

List Manager, F+W Media
4700 E. Galbraith Road
Cincinnati, OH 45236

Safety Note

Safety is your responsibility. Manufacturers place safety devices on their equipment for a reason. In many photos you see in *Popular Woodworking*, these have been removed to provide clarity. In some cases we'll use an awkward body position so you can better see what's being demonstrated. Don't copy us. Think about each procedure you're going to perform beforehand.

Firmer Chisels vs. Typical Bevel-edge Chisels

I am wondering what the difference is between a firmer chisel and the typical beveled chisel that you find today, and what the advantages and disadvantages are of firmer chisels.

— John M. Wert, Centre Hall, Pennsylvania

Firmer chisels are different than the modern bench chisel in that they don't have bevels on their long edges. They are rectangular in cross section.

The bevels exist on modern bevel-edge chisels to allow the tool to get into the acute corners of some joints, particularly dovetails. However, many modern bevel-edge chisels are so poorly made that the bevels don't work. There's so much flat area left on the edges that they are, in essence, the old-style firmer chisel.

Firmers were the most popular style of chisel in the 19th century, and so they are readily found on the secondary market. However, in the 20th century, bevel-edge chisels became popular and so that is what is in virtually every catalog today.

— Christopher Schwarz, editor

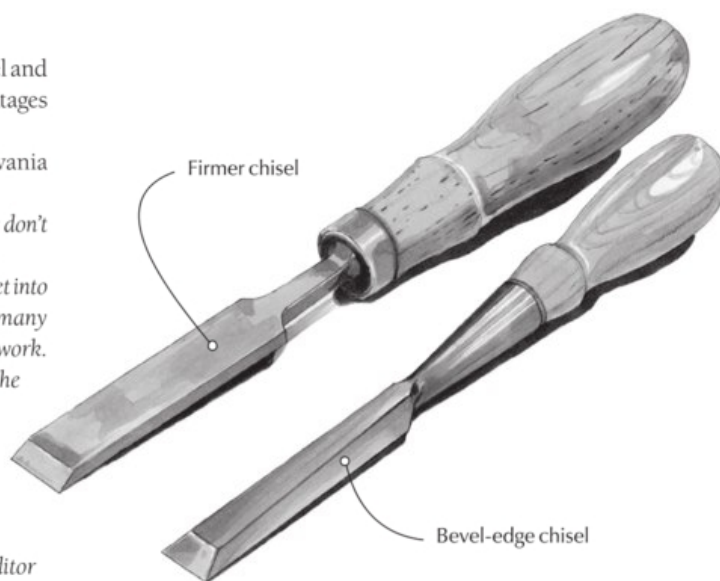

What Sealer Over Water-base?

I am in the process of trying a couple new things. First is building some cabinets with cherry, which I haven't used before. Second, because all the ready-to-use stains turn out too dark for the room the cabinets will be in, I will try dyes. I want to stick with my water-based polyurethane finish because of its ease of application for me. I understand that I need some sort of sealer over the dye to prevent bleed-through. Do you have a recommendation regarding what sealer to use?

— Hal Smith, via e-mail

You are correct to ask about water-based finishes over water-based dyes. I conferred with Bob Flexner, contributing editor, on this and we agree that if you're applying topcoats with spray, you should not have any issues other than a bit of color transferring into your first coat, which would not be noticeable on a completed project.

But if you're applying the finish with a brush, you'll notice a bit of color transference mainly from the sanding dust that's on your project after you knock down any raised grain from your dye. That's to be expected. If you continually brush, you may notice additional bleed-through (dye flowing into your topcoat).

In this scenario, it would be best to apply a sealer coat that's not water-based. I would use shellac. You could also use any wipe-on finish that's oil-based. Once your sealer coat is dry, return to your favorite water-based topcoat to complete the project.

— Glen D. Huey, senior editor

Why are Miter Saws Pushed?

The article on testing 12" sliding-compound miter saws in the December 2008 issue of *Popular Woodworking* (#173) raised a question I have had for some time. That is, why do you

push the blade of the miter saw through the workpiece but you pull the blade through with a radial arm saw? The blades of both saws rotate in the same direction. Is it because you actually start the cut on the miter saw with a plunge motion?

— Dominick Mazzitelli, Turnersville, New Jersey

The reason for pushing the miter saw is because of the plunging action of the saw's head. If you pull it toward you, there is a chance of the saw head rising up during the cut. Although the blade direction is the same for both saws, the tooth geometry on miter saw blades is engineered for efficient cutting on the push stroke.

The head rising up isn't an issue with a radial-arm saw. In addition, it would be awkward with a radial-arm saw to place material for cutting with the saw in a position to be pushed into the work.

— Robert W. Lang, senior editor

Won't Wedged Tenons Split the Craftsman Bookcase Sides?

My question concerns the Craftsman bookcase in the August 2008 issue of *Popular Woodworking* (#170). I was taught that when you wedge a through-tenon, the wedge should be perpendicular to the grain of the mortised piece, regardless of the orientation of the mortise opening, to avoid splitting the mortised piece. But in the featured bookcase, the wedges run vertically, along the grain of the sides. Is there a special reason for this choice?

— Tom Ryan, via e-mail

I oriented the wedges that way simply for the sake of aesthetics. I'm of the opinion that it would be nearly impossible to split the sides of the bookcase with small wedges such as those I used.

— Robert W. Lang, senior editor

Safer Dado-stack Use for Tenons

I enjoyed Megan Fitzpatrick's article on the Shaker stepback (February 2009, #174). I, too, use the dado-stack method that Megan discusses for creating tenons. However, I strongly urge one slight change in her methodology.

I also cut the tenon using a miter gauge and table saw fence, but I make the first cut without having the workpiece against the fence, then make subsequent cuts working the piece over gradually on each cut until it finally touches the fence. This minimizes the chance for kickback.

We all recall the admonition about not using the miter gauge and the fence at the same time. My method is the one exception to that rule, because I cut away all the material that could cause kickback before I flush the piece with the fence. I learned the hard way about kickback using Megan's method when my 5-horsepower table saw shot a workpiece against the back wall of my shop.

— Bill Jordan,
Andalusia, Alabama

Cross-grain Construction Query

I have often thought of making a box very much like the H. Gerstner & Sons tool chest (featured in the April 2008 issue, #168), but I have some concerns about how to attach the top section of the sides and back. It appears that they execute a classic cross-grain glue-up.

How do they get away with it? I suspect I would end up with a very nice toolbox with cracks in the sides and back. Any suggestions?

— James Hansford, Mosinee, Wisconsin



You would expect to have issues with a cross-grain assembly such as that of a Gerstner tool chest, but they don't experience those problems. They did, however, have a few issues when building a walnut cabinet and had to discontinue using that wood.

Here's how they skirt potential cross-grain problems: They use quartersawn hardwoods. They specialize in quartersawn oak, and in the video (available at popularwoodworking.com/video) I mentioned that cherry had just surpassed oak as the wood of choice. The cherry they use is also quartersawn. Using this material, coupled with the thinness of the case sides, has all but eliminated any cross-grain issues for the company.

My advice would be to use quartersawn kiln-dried lumber and keep the sides thin. You shouldn't experience any problems. But there's always a chance you could experience problems.

— Glen D. Huey, senior editor

Should I Get a Combo Machine Or a Stand-alone Planer?

I'm debating getting a planer/jointer combo machine or just a planer. I want to get a good product that won't bog down or cause problems. My main question is: Could I get by with just a planer and use a sled to prepare (joint) the first side? It would be great if I could get by without the added expense of a jointer.

— Ken Hessedal, via e-mail

I wouldn't want to work wood without a powered jointer. I have worked with the sleds that you describe and they are so slow and fussy that I instead use a handplane to dress one side of the stock then run it through the planer (this is what I do with stock that is too wide for our jointer).

We feel strongly here at the magazine that accuracy begins with the jointer because it makes the flat edges and surfaces that lead to flat boards that lead to accurate joinery.

Most woodworkers who try to get by without a jointer eventually give up and buy a jointer. The jointer/planer combo machines (especially the Grizzly one we reviewed in February 2008, #167) are very nice. If I had to recommend a way to save money, I would recommend an 8" jointer and a 12" portable planer.

— Christopher Schwarz, editor

Saw Safety Ignored

While I don't consider myself a "safety Nazi," a photo on page 25 of the November 2008 issue (#172) caused me to write. You show a saw in operation with all the safety gear removed. No riving knife, no blade cover, no anti-kickback pawls.

And while we're accustomed to seeing this "guard removed for clarity" conceit in the magazines, what's worse in this case is the operator in the photo. No hearing protection. No eye protection. And he's wearing puffy sleeves that could be grabbed by the saw's blade, pulling him into the cut with disastrous results. Please, please, please ask Adam Cherubini to show more respect for the safety of the reader (and himself) in future issues. **PW**

— Mona Oster, Dallas, Texas

Question? Comment? We want to hear from you.

Popular Woodworking welcomes comments from readers about the magazine or woodworking in general, as well as questions on all areas of woodworking. We are more than happy to share our woodworking experience with you by answering your questions or adding some clarity to whatever aspect of the craft you are unsure about, and if you have a complaint, we want to address it whenever possible.

Though we receive a good deal of mail, we try to respond to all correspondence in a prompt manner. Published correspondence may be edited for length or style. All correspondence becomes the property of *Popular Woodworking*. Send your questions and comments via e-mail to popwood@fwmedia.com, or by mail to:

Letters
Popular Woodworking
4700 E. Galbraith Road
Cincinnati, OH 45236

TRICKS OF THE TRADE

EDITED BY PAUL ANTHONY

THE WINNER:

Vise-clamping Odd Shapes

In my work, I often need to secure odd-shaped pieces in my standard bench vise. To do the job, I devised a pair of auxiliary cauls that attach via rods to thick wooden pads on my vise jaws. One of the auxiliary jaws is fixed, while the other one can swivel to accommodate pieces with non-parallel sides.

To outfit your vise, begin by making a 1"-thick hardwood facing block for each jaw. Using the drill press, bore three equidistant 1/2"-diameter holes through the width of each block to accept the rods. (Drilling the holes completely through prevents clogging from chips.) Then attach the blocks to your vise jaws with screws or bolts, aligning the top of each block with your workbench surface.

Make the cauls from stout hardwood that will resist flex in use. Mine are 18" long, 2 1/2" wide and 1" thick; make yours from any size that suits your work. Next, use dowel centers to transfer the 1/2"-diameter rod-hole locations to the underside of the cauls. The swiveling caul needs only one hole in the center, while the mating caul is drilled to match only the two outer holes. Bore these holes at least 3/4" deep, again using the drill press. (This hole configuration allows interchanging the fixed and swiveling cauls on either vise jaw.) Glue 1/2"-diameter steel rods or wooden dowels into the cauls, leaving about 2" projecting to fit in the wooden blocks. Face the bearing surface of

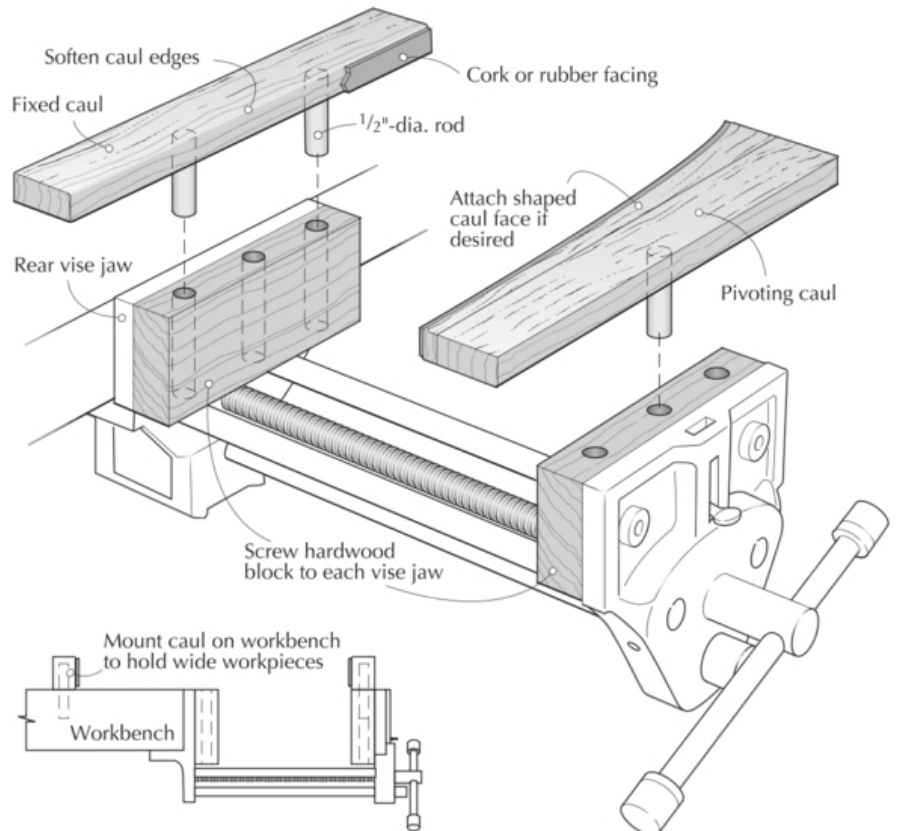

each caul with rubber or cork to aid gripping, and ease sharp edges with sandpaper.

To hold curved and odd-shaped pieces, attach a suitably shaped piece to one or both of the cauls. For panels and other wide work,

the innermost caul can be mounted in holes drilled in the workbench top instead of the holes in the inner vise jaw.

— Sarah Dieterichs,
Hellertown, Pennsylvania

Cash and prizes for your tricks and tips!

Each issue we publish useful woodworking tips from our readers. Next issue's winner receives a \$250 gift certificate from Lee Valley Tools, good for any item in the catalog or on the web site (leevalley.com). (The tools pictured at right are for illustration only, and are not part of the prize.)

Runners-up each receive a check for \$50 to \$100. When submitting a trick (either by mail or e-mail) you must include your complete mailing address and a daytime phone number. If your trick is selected for publication, an editor will need to contact you. All entries become the property of *Popular Woodworking*. You can send your trick by e-mail to popwoodtricks@fwmedia.com, or mail it to Tricks of the Trade, *Popular Woodworking*, 4700 E. Galbraith Road, Cincinnati, OH 45236.



Calculating Odd Miter Angles

Sometimes, calculating odd miter angles can be mystifying, but here are a couple math-free tips to help you out. To lay out a miter on two boards of differing width, first overlap the two corners at 90° as shown. Trace along the edge of the upper piece, connect the corners of the underlying traced area, then set a bevel gauge to this angle for laying out your joints.

The same principle works when determining the miter angle for pieces that don't meet at 90° – for example when fitting baseboard to a non-square room's corner. Lay one intersecting piece on top of the other, trace both edges of the upper piece, then connect the corners of the traced lines on the lower piece to find your angle.

— Ron Jones, Phoenix, Arizona

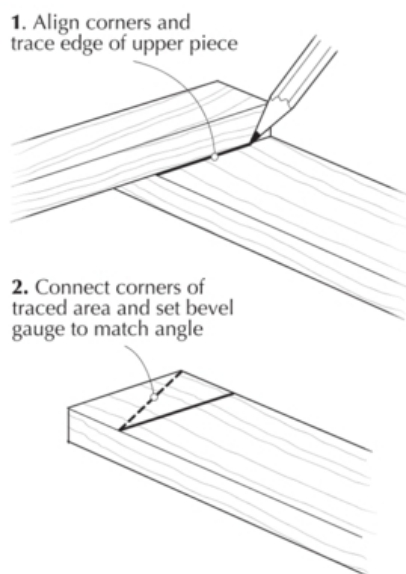

PIECES OF UNEQUAL WIDTH

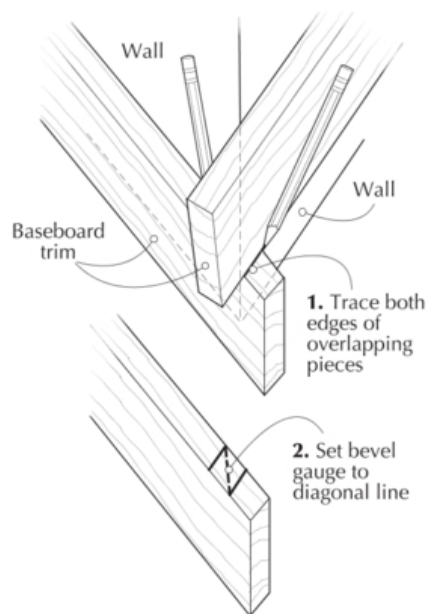

NON-SQUARE CORNER

Removing Damaged Screws

I recently had to remove some old Phillips-drive screws on which the heads had been stripped, or cammed out, causing the screwdriver to spin freely in the heads. Using a trick learned in my days of repairing airplanes, I outfitted my drill with a bit that was slightly smaller than the root diameter of the screw, and drilled straight down through the center of the head and into the screw shank. Doing this allows greater penetration of the driver tip so its flutes can once again seat properly in the screw's slots. It also helps to lightly tap the driver into the drilled screw head before turning it. For best purchase, make sure to use a driver with an undamaged tip.

— James Keller, Matthews, North Carolina

Sandpaper Cutting Board

Having grown tired of bending and tearing sheet sandpaper again and again to get the size I need, I finally decided to employ the time-honored trick of cutting it with a hacksaw blade screwed to a plywood panel. The jig is very quick to make, and it allows you to simply slip a sheet of sandpaper under the blade and tear upward while holding the blade down.

Make sure to insert a thin washer (or a couple small sandpaper scraps) under the blade at each end to raise it slightly off the panel. For quick alignment of sheets for cutting, I drew reference lines on my board, although you could tack some thin guide strips in place instead.

— Gregg Lipanovich, San Clemente, California

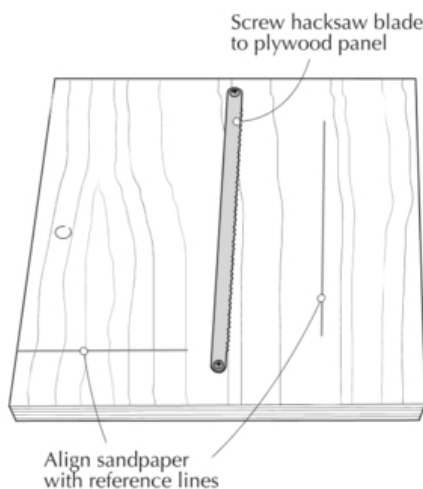

Handscrew Headstand Revisited

I saw the “Handscrew Headstand” trick in *Popular Woodworking* #172 (November 2008), which showed how two stacked handscrews can be used to hold a stick on end at the drill press. That two-clamp approach works well for securing longer stock, but can be cumbersome for shorter pieces. When drilling into the ends of short pieces, I hold them on end using a single handscrew with 90° V-notches cut into its jaws as shown.

For safety and accuracy, the mating notches must be carefully aligned with one another and their walls must be square to the sides of the clamp's jaws. You could cut them on the band saw, with a jigsaw or a handsaw. Include a small notch for smaller workpieces.

— Alan Broddon, Clayton, Missouri

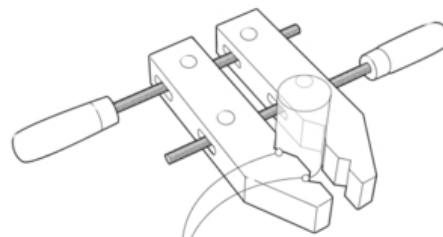

Notches hold short pieces on end for boring on drill press

Benchtop Screw Stops

To create a planing stop on my workbench, I decided to go the simple route. I installed and countersunk a short row of #12 brass flathead screws near the edge of the bench, spacing them an inch or so apart. I can adjust them just slightly above the surface of the benchtop for planing even very thin stock, then screw them down below the surface when not in use. For wider stock, add more screws as necessary. Because brass is soft, the screws have less of a tendency to damage cutters during accidental contact.

— John Borgwardt, Eau Claire, Wisconsin

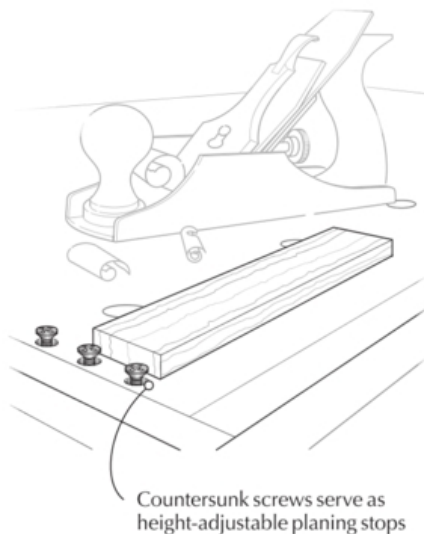

Countersunk screws serve as height-adjustable planing stops

A Slick Digital Angle Gauge Trick

I've found that my new digital angle gauge is a great tool for setting an accurate angle on a miter gauge. To set the desired angle, first stand the miter gauge on its face on the rip

fence's rail or front of the saw table with the guide bar dangling below as shown. Zero out the gauge to establish the reference plane. Next, attach the digital angle gauge to the side of the bar, adjust the bar to the desired miter angle, and lock the miter gauge. Voilà! You're ready to go.

— Roland Weisser, Whitfield, Mississippi

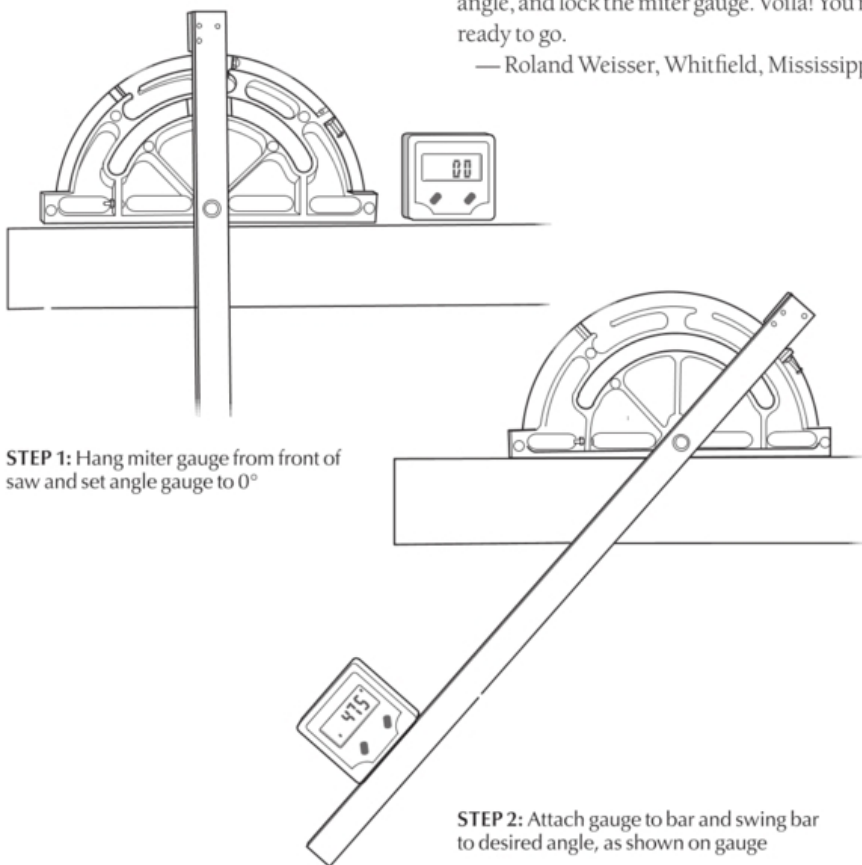

STEP 1: Hang miter gauge from front of saw and set angle gauge to 0°

STEP 2: Attach gauge to bar and swing bar to desired angle, as shown on gauge

Tape-clamping Small Miters

When gluing miters for small mouldings, clear packing tape makes an ideal clamp. Begin by placing a strip of tape across the bottom of the joint; this will prevent glue squeeze-out from getting on your bench. As you push the joint together with one hand, wrap the tape up and over the top of the moulding, pinching the ends of the tape together as you go. This applies even pressure on the joint and keeps it from sliding apart as the glue dries.

— Linda Watts, PW art director



STEP 1: Press glued miters together on top of wide packing tape

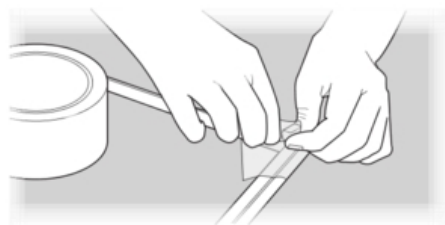

STEP 2: Press tape ends tightly together on top of joint

Instant Table From Pipe Clamps

Ever find yourself in need of a temporary shop table for finishing or staging parts in process? Well, if you have four 36"-long pipe or bar clamps and a piece of plywood, you have an instant table. Just attach the clamps to the corners of the plywood to create a sturdy temporary platform that breaks down quickly and doesn't waste any shop space when not in use. **PW**

— Aaron Mashburn, Wichita Falls, Texas

A Sticky Situation

Six common situations where specialty glues serve you well.

It goes without saying that most of our projects would be nothing more than a loose assembly of parts without the holding power of glue. Thankfully, modern adhesives are accessible, usually inexpensive and keep us from having to mill wedged tenons for everything we build. Most woodworkers begin by using good old yellow glue (polyvinyl acetate or PVA). It's a great general-purpose glue that serves me well for about 90 percent of my tasks. But there are a number of unique glues that work particularly well for specialized applications.

Working With Veneer

Veneer requires two major things from glue – rigidity and a long open time. Sounds like a job for urea formaldehyde! There are two brands of urea formaldehyde that I use in my work. DAP's Weldwood is a powder that you mix with water and Unibond800 is a liquid resin that is mixed with a powder activator.

Because of its water content, Weldwood is not ideal for veneering. By introducing water into the equation, both the veneer and the substrate swell. Then as the glue cures and the water evaporates, there could be open seams and cracks – that's trouble. However, this same property is what makes it great for things such as bent lamination, where a little extra moisture helps the laminations flex.

For veneering, Unibond800 is my glue of choice. Of course, if you want to be a traditionalist, you can try hammer veneering with hide glue. But that's a subject for another article.

Online EXTRAS

To watch The Wood Whisperer select, mix and use the appropriate glues for veneer, go to:

popularwoodworking.com/apr09



A glue for every reason. While woodworkers generally rely on yellow glue (polyvinyl acetate) for most glue jobs in the shop, depending on the task at hand, there might be a better choice available.

Hurry Up – The Glue is Drying

It's a common scenario. You're gluing up a project and before you can get everything situated, the glue starts to dry. Panic sets in. You pull out your trusty dead-blow hammer and proceed to beat the daylight out of your latest masterpiece. Now unless you're into distressed furniture, this is bad.

To avoid this situation, it's a good idea to use glue with a longer open time. You should have enough time to assemble the parts, position your clamps and check to make sure each and every piece is positioned correctly.

Two of my favorite options are slow-set epoxy and just about any urea formaldehyde glue. Both give you up to 30 minutes of open time and that should be enough for just about any project, including those notoriously long bent-lamination clamping sessions.

So what are the downsides? Epoxy and some varieties of urea formaldehyde can be pricey. And both should be handled carefully as they do contain harmful substances (refer to manufacturers' instructions for details). These safety precautions are really just a minor detail and are well worth the time and effort for the extra open time you get in exchange.

Designed to Fail?

When we build our projects, it's important to think about their future – not necessarily next month or even next year. I'm talking 10 or more years from now. A chair, for example, with constant use, will almost certainly be in need of repair at some point in its lifetime. So it's not a bad idea to use glue that facilitates easy repairs.

One of the best (and oldest) glues for this

purpose is hide glue. Hide glue is made, as you might expect, from animal hides (and it smells like it, too). The great thing about this stuff is that it can be reactivated again and again over its lifetime. So if a joint becomes loose or a part needs to be replaced, the entire project can be taken apart and reassembled with the help of a little heat and moisture. In addition, hide glue binds very well to itself, so there is no need to completely remove the old glue from the joints.

Hide glue comes in two forms, a dry form that has to be mixed with water over heat, and a newer pre-mixed liquid variety that is ready to use. Many folks shy away from hot hide glue because it can be messy and time consuming. Fortunately, the pre-mixed liquid forms are now available and we have hide glue ready to go at a moment's notice. Not only are these pre-mixed glues just as strong as their hot brethren, they are also competitive with the modern PVA glues that we know and love.

The Joint is Just a Bit Sloppy

Despite your best effort, you will on occasion produce a joint that is just a bit too loose. To make the joint again is one option, but using gap-filling glue could very well save you a lot of time and effort. Remember though, not all glues have gap-filling abilities, and some are just downright terrible at it. (I'm talking to you, polyurethane glue!)

Glues such as epoxy and urea resin are my favorite glues for this task. Each is capable of filling occasional small gaps and making loose-fitting joints structurally sound.

Superficial Repairs

There are two glues that I turn to whenever I have to repair knots, digs, scratches or tear-out: cyanoacrylate (CA) glue and epoxy. CA glue, also known as Super Glue, is a fast-drying brittle glue that does a fine job of filling small holes and cracks as well as reattaching small pieces of wood that may have torn out. And if you have a little bubble in your veneer, CA glue is great for that, too. Just use a syringe to inject some glue under the veneer and clamp it down for a few minutes.

If you're really in a rush, like I usually am, pick up a can of quick-set activator. When sprayed over the CA glue, it instantly causes the glue to cure. Another great trick is to mix the glue with a little sawdust to serve as a color-matched filler.

Epoxy, particularly the five-minute variety,



Best old glue. Hide glue is great for joints that are likely to need repair in the future.



A quick fix. Accidental chip-out can be reattached in seconds with quick-drying CA glue.



A fill-in filler. CA glue and sawdust make great homemade filler.



No longer loose. Stabilize knots and make them look natural with epoxy and dye.

is also great for quick repairs, but it does take a full five minutes to cure. I typically use it for filling holes and knots on horizontal surfaces. Its self-leveling nature and ability to take dye make it perfect for this type of thing. Aside from the dye, you can also add sawdust to the mixture to create nice homemade filler.

Weather the Storm

If you build any outdoor furniture, you should definitely be concerned with your choice of glue. Standard Type I PVA glue is not adequate for this task, as it has no water resistance. Fortunately, Type II PVA is water-resistant and Type III is waterproof. But there are other glues to consider as well, including epoxy, polyurethane and urea formaldehyde. These glues excel in their "water-proofness" and take just about anything Mother Nature can dish out. However, each of them has its own unique working properties, shelf life and usefulness in other projects, so you'll have to decide which one best suits your needs.

These are just a few examples where specialized glues can get you out of a sticky situation. Of course, there are many other scenarios and numerous other glue options, but these are the ones that I rely on time and time again.

I am sure they'll work for you, too. Now, I realize that keeping all these different types of glue on hand at all times can be expensive and wasteful, so it's good to know that our traditional PVA wood glues suffice for most woodshop tasks. But it's like the old saying: It's important to use the right tool for the job. And glue, after all, is nothing more than a tool in our woodworking bag of tricks. **PW**

Marc is a professional woodworker as well as the creator and host of The Wood Whisperer (thewoodwhisperer.com). The Wood Whisperer (an instructional Internet woodworking show) represents Marc's three passions: woodworking, technology and education.

About This Column

Our "Wood Whisperer" column features woodworking thoughts and ideas, along with shop techniques from Marc Spagnuolo. Each column has a corresponding video related to the techniques or views expressed in the column available at popularwoodworking.com/video.



Hold Handwork Without a Vise

Get started with hand tools without spending a bundle on a bench or vise.

A major stumbling block on the road to enjoyable woodworking is “lackoftoolaphobia,” the fear of not being able to do something without the best possible tool available. Common among power-tool woodworkers, it can also strike the would-be Neanderthal.

A basic skill such as sawing to a line can take you a long way in woodworking. If you practice, then cutting straight and where you want to isn't that demanding. If you can make cuts repeatedly and consistently, how hard could it be to hand-cut a dovetail or a tenon?

You can satisfy that curiosity without investing in a state-of-the-art bench equipped with a fancy vise. Some scraps of wood and a few clamps will get you started. You will need a saw, but you'll need some experience before you can tell the difference between a good saw and a bad one.

When you start to add hand-tool skills to your woodworking repertoire, the important



Simple solution. A vise is nice, but don't let the lack of one keep you from getting started with hand tools. This simple device will hold work vertically for cutting joints by hand.

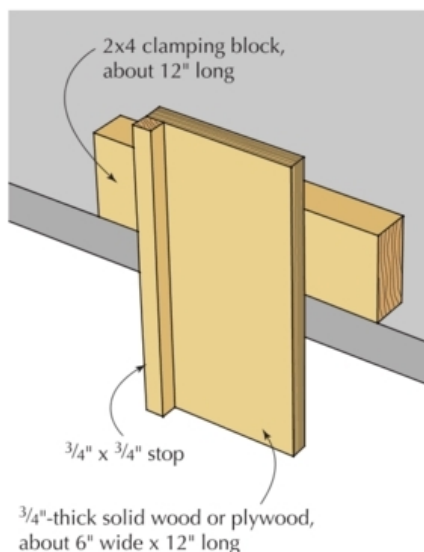

VERTICAL BENCH HOOK

thing is to acquire skills before you accumulate tools. Then you can load up on the fancy stuff knowing why you absolutely need six or seven different saws, and you'll be able to use them appropriately.

In our November 2007 issue (#165), we wrote about a basic bench hook, a simple work-holding device for making cuts in wood held horizontally. This fixture is a bench hook turned 90° so you can hold work vertically to cut dovetails or tenons.

Start with a piece of 3/4"-thick solid wood or plywood, about 6" wide x 12" long, as a base. Glue a 3/4" x 3/4" strip along one long

edge. On the opposite side, glue and screw the thickest piece of wood you can find to the 6" x 12" piece. I used a piece of 2x4, about 12" long. Attach it so that a couple inches of the base extend beyond the long edge of the cross-piece.

When the glue has completely dried, clamp the cross-piece to the edge of a solid, flat surface with a clamp on each end. If you have a bench, use that. If not, use anything handy and solid, such as a machine table or even your kitchen counter.

Take your workpiece and with a third clamp, fix it to the jig with one edge tight

against the square edge and an inch or two sticking out at the top. Pick up your saw and get set to work.

But First, Some Practice

Woodworkers are an interesting bunch. Lack of confidence will keep someone from attempting something, but as soon as that hurdle has been crossed, it is often assumed that one's first dovetails may as well be cut in a wide, expensive piece of mahogany that's part of a complex piece of furniture.

Spend some time getting used to how the saw feels in your hand, and what it feels like to make a cut. The best way to do this is to make a lot of cuts. Get some cheap wood and make as many cuts as you can in the end of a board. Don't bother marking lines, just cut.

As you get the hang of it, get out your square and see how you've done. The design of saws has evolved to make things easy, and if you can keep from thinking too much, the weight and balance of the saw, along with gravity, will take care of the hard part. You just need to learn to steer. When you're comfortable starting the saw and cutting straight across and straight down, cut off the end of your board and repeat the exercise by making angled cuts.

Do all of this by eye, and find a vertical angle that looks like a dovetail to you. Make as many cuts as you can, and after a few see if you can make them parallel to each other. Go halfway across the board angling to the left, then make more cuts that angle to the right on the other half.

When you've ruined the end of the board again, cut it off square and practice making cuts that angle front to back and are straight up and down. Keep your pencil and your layout tools away for now. The idea is to get comfortable with the process and figure out how to hold the saw, where to put your feet and how to move your arm.

Now Worry About the Lines

The half-hour or so that you spent making cuts without lines will enable you to move to the next step with confidence. Now you can practice cutting to a line knowing how it feels to start and make a cut. The first part is making a good line. A pencil line shows where the line should be, but a knife line will actually help you make a better cut.

As it is with all other tools, you can spend a lot of money for a nice marking knife. Someday that will make perfect sense, but for now

use a utility knife or an X-Acto knife. Run the point of the knife along the blade of your square or bevel gauge. A knife line can be hard to see; you can run a pencil along it to make it more visible.

If you can make the first saw stroke accurately, you are well on your way to being adept with the saw, and the knife line provides a channel for the saw teeth to ride in. Make a gentle stroke to keep from jumping out of that channel. The saw wants to cut straight, and it wants to be balanced vertically. If you force the process you will be in the way. If you just watch and let it happen, the saw will do most of the work. **PW**

Bob is a senior editor of this magazine, and the author of "Shop Drawings for Greene & Greene Furniture."



Three clamps and you're ready. With the work clamped to the jig, and the jig clamped to your bench, you can practice making cuts with a handsaw.

The Cheap Approach to Handsaws

If you are new to using a handsaw and want a decent tool on a budget, there are a couple reasonable options. The first is to purchase a Japanese Dozuki-style saw with a replaceable blade and a reinforced back. Expect to pay \$30-\$50. Stay away from the really cheap saws at the big box stores.

Japanese saws are usually sharp and functional when new, and they cut on the pull stroke. The teeth are exceptionally hard, a condition with both pluses and minuses. The good thing is that the saw will stay sharp. The bad things are that it is easy to snap off a tooth if you force the saw while making a cut, and that the teeth can be too hard to be sharpened.

We work with harder woods than the Japanese do, and while a Dozuki will outperform a Western-style saw at a comparable price, many woodworkers find pushing a Western saw preferable. A quality backsaw costs about as much as a good router or jigsaw does. It's a worthwhile investment, once you're adept enough to recognize the fine points.

There is a new alternative, the Veritas dovetail saw (leevalley.com). At \$65, it nicely fills the gap between cheap saws that don't work at all, and the high-end saws. It also allows you to learn with the same technique you'll need if you decide to move up to a premium saw. — RL



A good start. Many woodworkers start with a Japanese Dozuki as their first joinery saw. It is sharp, functional and doesn't cost a fortune.



A new alternative. A good Western-style joinery saw can be expensive, but the new Veritas dovetail saw is a quality tool at a reasonable price.

Shaping the Splat

Building a Philadelphia Chippendale chair – Part 4

I'm continuing with my reproduction of an 18th-century Philadelphia side chair. These chairs are often called "Chippendale chairs," no doubt referring to the London cabinet-maker Thomas Chippendale who published a book of his designs in 1754. Chippendale's "The Gentleman & Cabinetmaker's Director" (reprint available from Dover Press) contains images largely of rococo furniture. Even in the first printing, Chippendale did not include many of the design elements typically associated with Philadelphia "Chippendale" chairs. No ball-and-claw feet were depicted. Chippendale preferred the seat upholstery to cover the seat rails, a feature rarely seen on Philadelphia Chippendale side chairs (though it would emerge in later styles). And the scant dimensions offered by Chippendale aren't apparent in Philadelphia side chairs. So why do we call them Chippendale chairs when the dimensions are different, the feet are different and the upholstery is different?

I think the reason is that the designs of the Philadelphia chairs' backs are often very similar to those shown in Chippendale's book. Chippendale's rococo designs, replete with ribbons, bellflowers and acanthus leaves, were a significant departure from the earlier baroque solid-splat chairs. We know at least that some prominent Philadelphia cabinet and chairmakers either had copies of the "Director" (including Thomas Affleck and possibly Benjamin Randolph) or had access to a copy through The Library Company of Philadelphia (of which several notable Philadelphia cabinetmakers were members). A few surviving chairs are near-exact copies of illustrations in Chippendale's seminal book.

Judging from what I have seen, which is admittedly a small subset of all the chairs classified as "Chippendale" chairs, it would be a mistake to think the "Director" was used for



A step back. I've made a lot of mistakes with this chair so far. My joinery isn't great; I cut my back splat stock too small. And though I didn't mention it earlier, I think I undercut my crest rail a little. But this is a really beautiful design. As I look at this photo, I can see a couple areas that need attention. Artists sometimes step back from their canvases so they don't lose the design in the details. That seems like a good idea for this project.

project plans in 18th-century chair shops. Philadelphia chairmakers did their own thing. Clearly we see stylistic relationships between the chairs in the “Director” and surviving chairs. The acanthus-leaf carving, the ribbons and the Chinese or Gothic motifs may have been lifted whole from Chippendale, but these were rearranged into new patterns, very likely unique to each customer.

I’ve devoted a significant number of pages urging you to design your own period furniture. It’s an issue I feel strongly about. But frankly, I don’t feel I’m up to the task of designing a Chippendale-style chair back myself. It’s not so much the artistic part. I don’t understand how aesthetic choices I make for my chair’s back design will affect the wood work ahead of me. I think it’s possible that I can design something that I can’t practically build. I also don’t trust that Chippendale’s designs were easy to produce. So I’ve decided to copy a chair I have seen and photographed. At least I know its design can be made (and made without power tools).

Sawing the Back Splat

I traced the back of my chair onto a piece of Kraft paper so I knew exactly what I had to work with. Then I freehand sketched the

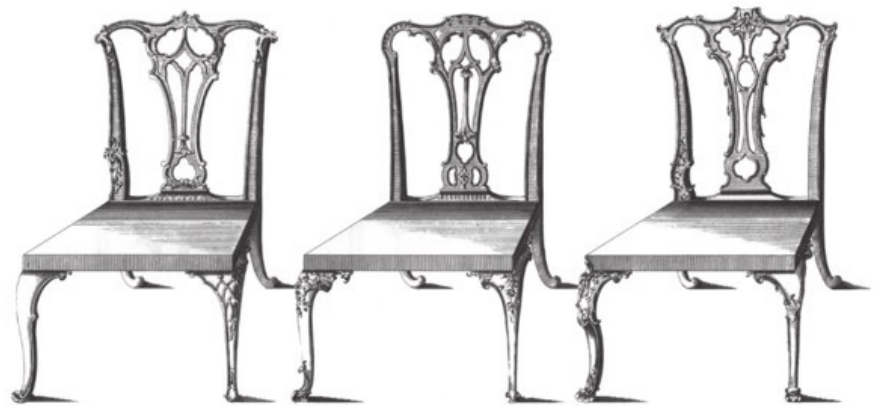

Inspiration. I think the back of the chair on the left is remarkably similar to the chair I am copying. It’s similar, but clearly not a faithful reproduction. Nor does it seem to be a naïve attempt at reproducing one of Chippendale’s designs. The chairmaker in colonial Philadelphia who made the original chairs I am copying may have seen this plate in Chippendale’s book and been inspired by it.

design I wanted. I thought my splat was wide enough for this design. I even added little bits before I shaped the splat thinking these would account for my chosen design. I was wrong. I tried shoe-horning the design into the stock I prepared. I worked on it for quite some time, but I finally gave up. I could have scrapped the splat and made a new wider one. But once again, I decided to fix it as best I could and keep moving forward. This certainly isn’t the first mistake I’ve made on this project and it won’t be the last.

I cut out the design, and laid the paper directly on the mahogany. I marked out the design with white chalk. Pencil can be hard to see on mahogany. By the way, we know 18th-century craftsmen had pencils. But we also see evidence of chalk fairly regularly on period furniture, so we know it was also used.

I wasn’t sure if it was better to saw out the splat before or after it was glued into the chair. I can see advantages and disadvantages to both ways. I decided to try to saw the shape into the splat before it was glued into the chair. My concern was that I would have trouble getting my frame saw into some of the small areas. Eighteenth-century chairmakers might have used thin saws like keyhole saws for this sort of work.

I roughed out the shape using my 12” scrollsaw. The features of this chair are pretty delicate. I was torn between being bold and cutting very close to the lines, and being more



Second guesses. Designing the back is a smart first step. I’m not sure what went wrong with this chair, though. The back splat is just a bit too narrow for this design. The dark lines represent the stock I have. The pencil lines are what I think the design should be.



Added width. I cobbled these blocks onto my splat to give me enough width for the design I wanted. I’m not sure how these blocks will affect my carving or if they will be very noticeable in the finished piece.



Tight curves. I find it helpful to hold both ends of my scrollsaw to make tight turns. Waxing the blade also helps. I made this saw many years ago and I’ve found it invaluable. Its 12” blade is plenty long enough for thin stock and it makes this technique comfortable.



Leave the lines. I sawed this out with my 12" scrollsaw. I left the chalk lines and tried to stay away from the details. I'll clean up to the line with my spokeshave and rasp after this is attached to the chair.

timid and leaving more of the line. Usually, I tend toward the aggressive side. The original chairs I've seen have very delicate features. But I was worried about cracking the back, either in the vise or from sawing. From what I could see, these cuts were made perpendicular to the front face of the splat. Some period scroll work, Chippendale-style mirrors for example, are all undercut. The cuts aren't perpendicular to the front surface. They are beveled through the thickness to help punctuate the design. I wondered if this was true of the chairs. I didn't see it, but it's worth looking for if you get a chance.

Taming of the Shoe

With the splat roughed to shape, I turned my attention to the shoe moulding. The shoe is the little block that rests on the rear seat rail that is mortised to receive the bottom of the back splat.

Period shoe mouldings were glued (I used hot hide glue) and always nailed in place. Yes, I said nailed; the heads are evident on the top surface. And yes, these appear to be original, not repairs. Don't shoot the messenger! I used Tremont 2d brads. I filed the heads down until



Rabbet. Here's the shoe I made in the first article in this series (Issue #172). I used my fingers to guide my square rabbet. Just a couple passes are all it takes to complete this little step.



Gouge or scrape? I rounded the top part with a hollow plane. You don't need a fence for these planes, just a little practice. I used a scraper and my cabinet file to profile the end-grain portion of this moulding. I think I would have done better with a sharp gouge. Scraping across the grain should always be a last resort.

they were very thin and just a little larger than the shank of the nail. Hoping to avoid splitting the shoe, I bored pilot holes with a brad awl. Dave Hoffman, who does 17th-century period work, told me it's best to tap these in slowly if you want to avoid splitting small parts. I used my small tack hammer. These nails should generally be aligned such that the flat sides of the nails are parallel to the grain. I finished driving them with a nail set, but I didn't bury the heads. I was just too scared of cracking the shoe. I filed the heads flush with the wood. It



Easy work. With the shoe now turned on its back, I gouged the cove. This looks like a bigger job than it really was. Carving mahogany is very easy.



Shoe design. Here's the finished shoe moulding. Some chairs' shoes look just like this. The chair I am basing this one on featured carved gadrooning around the upper surface. I might just try it!

didn't appear that any such effort was taken on the originals.

Gluing Up the Splat and Crest Rail

I decided to try to do the glue-up in stages. With the shoe in place, I glued the splat into the crest rail. I made the mistake of putting hide glue on the tenon shoulder. (So what's that, mistake number 48?) This is an amateur's mistake. The glue gels the instant it hits the cold wood, preventing you from pulling up the joint. You get no strength between long



Nails. Period craftsmen tended not to trust glue. At least it was rarely the primary means of holding something together. On the chair I'm copying (and many others like it) the shoe moulding that holds the bottom end of the back splat is nailed in place. This could have been an extra security precaution, or it could have allowed the crest rail and splat to be assembled and possibly clamped without this piece moving.



Challenging work. What a difficult and unforgiving job this is! The gaps here between the crest rail and back splat were the result of poor gluing technique. I'm telling myself this may not look so bad when I carve this surface. I hope you build one of these chairs and I hope your experience is better than mine. If not, know that you aren't alone. I think this is the hardest thing I've ever built.

grain and end grain. It was stupid to put the glue there, and I knew it. I didn't take it apart. Once the glue was set up, I attached the crest rail to the back legs.

Eighteenth-century chairmakers in Philadelphia typically added glue blocks behind the back splat to reinforce the joint at the crest rail. These often fall off in time and some restorers seem to have chosen not to replace them. Different chairmakers shaped these differently. Sometimes they are simply beveled. On the chair I'm copying they were rounded. They



Added strength. The grain of these oft-missed and oft-missing glue blocks runs parallel to the crest rail. When present they add additional strength to the upper splat tenons.

may have been rounded with a gouge after they were glued in place. But they seemed so uniform in size that I wondered if they were shaped with a plane. This could be evidence of the scroll sawing happening after the splat was glued in place. The blocks may have been one long block, shaped with a hollow plane and glued in place before the sawing happened. That would explain the uniformity of the glue blocks on my chair.

Leg Shaping

The upper portions of the legs flare outward a little. They aren't just straight tapers. From the crest rail to about 6" down, I shaved the inside surfaces to create a nice curved shape. I then hollowed the outside surfaces of the legs to complete the effect. It's subtle but important. Curved things have a life to them that straight things do not.

The backs of the legs are rounded, transitioning from a nearly half-round shape just under the crest rail to a full rectangle at the rear seat rail. Again, the transition between these shapes is not a constant taper but a curve. This is not hard to do. Watch the untouched flat surface as you rasp or shave in the shape. The line between the curve and the flat will itself be a curve, not a straight line (indicating a straight transition).

The back of the crest rail receives that curved shape and continues it toward the splat. Although the ribbons in the back splat are not back beveled, the crest rail certainly is. Gouge cuts relieve material here, allowing the fine C-scrolls of the front to have much less thickness. The crest rail on the chair I'm copying was relieved to the thickness of the splat in these areas. In these photos, the lower portion of the crest rail is rounded. But the



A bit of flair and flare. The walnut straightedge indicates the edge of the original leg stock. The side opposite the straightedge was also shaped to accentuate the flare of the top of the legs.

upper surface will get rounded as well. I'm just waiting to get a handle on the carving before I do that work. Oh, and I was a bit light on the rounding. The back of the crest rail above the rear legs has an almost half-round cross section.

Mahogany responds well to rasps and files. While evidence of these tools is not present on ball-and-claw carvings, rasp marks are clearly evident on chair backs and the upper portions of the legs.

Conclusion

There's no question that these chair backs are artwork. Chippendale certainly thought so. And I think furniture scholars have correctly categorized these chairs according to the designs of their backs and not their legs or any other feature. That tells me the back (and not the legs or seat) is the most important part of this job. The carving will come later, and I'm nervous about that, but this shaping really has to be done just so. The legs must flow nicely into the crest rail. The splat must be sawn to give the illusion of ribbons beautifully flowing, winding their way from crest rail to shoe moulding. If you are wondering what makes these chairs difficult to build, add these issues to your list. **PW**

Visit Adam's blog at artsandmysteries.com for more discussion of traditional woodworking techniques.

Storage Bench

Keep the end of your bed organized in style.

The inspiration for this “I Can Do That” storage bench was simple – I wanted it. Ever since I picked up a king-size bed at a liquidation sale, I wanted a matching bench to hold my shoes at the foot of the bed. After seeing many designs that were running anywhere from \$250 to \$400, I thought to myself “I can do that” – and with a sheet of plywood and some pocket screws, you can too.

Cut to Length

For my stock, I used $\frac{3}{4}$ " Baltic birch plywood. Using your circular saw and a clamped-down straightedge jig to guide the cut, begin ripping your lumber. For tips on using the circular saw and guide, download the free “I Can Do That” manual at ICanDoThatExtras.com.

Start by ripping a 16"-wide panel from which you'll cut both side pieces, then cut them to length. Now rip the benchtop and bottom shelf to $15\frac{1}{4}$ " wide to accommodate for the $\frac{3}{4}$ " thickness of the back panel. Next cut the back panel to match the length of the benchtop and bottom shelf. Finally cut the height of the center divider to set the height of the storage cubbies.

This is My Good Side

Before cutting the side profiles with your jigsaw, examine your stock to choose the best outside face. With plywood it is more than likely that you'll have patches in several places; so make sure these will not be exposed.

Using a paper pattern for the feet, trace the outline along the bottom, flip the pattern for the opposite foot, then connect the tops of the feet with a square. For marking the notch on the top, trace the inside of a roll of packing tape.

Now you are ready to cut the profile with your jigsaw. (If you haven't picked up any Bosch T380B Xtra-Clean jigsaw blades, we



Storage with strength. Hidden pocket screws ensure this handsome bench will grace your home for years to come.

highly recommend them.) First cut the insides of the feet, making sure to stay on the waste side of your line. To connect the feet, start by cutting a gradual curve until you reach the connecting line as seen in the photo below. Then remove the rest of the waste.

To remove the wood for the top corner notch, first make several relief cuts – slice

toward the line as if you were cutting a pizza. This will make it easier to cut the final curve of the notch with your jigsaw or with a coping saw.

Then grab your rasp and some #120-grit sandpaper to clean up all your jigsaw cuts and you're almost ready for assembly.

Prepare for Pocket Screws

To make assembly a breeze, it's a good idea to cut all your pocket-screw holes in advance. First examine your stock for the best faces, then use your pocket-screw jig to make four evenly spaced holes along the ends of the three large panels. The faces needing pocket screws are the bottom of the benchtop, the bottom of the bottom shelf and the back of the back panel. The center divider needs only one row of holes along its top edge. Once all of your pocket-screw holes are drilled, sand all your parts up to #150 grit.

Upside-down Assembly

To assemble, start by placing the benchtop on two 2" blocks of scrap with the pocket holes



Angle of attack. Your jigsaw can't turn at sharp angles, so make a curved cut to the line.

facing up. Clamping these scrap blocks to the side panels provides a square platform for attaching the benchtop and creates the proper seat depth of 2". After flushing the benchtop to the front of the side panels, attach it with 1 1/4" pocket screws.

Next, locate the center of the benchtop and clamp a block in place to keep the center divider square as you drive the screws. Again, keep this piece flush to the front.

To position the bottom of the bench to the sides, clamp two 11 1/2" offcuts to the sides to provide a square platform. This prevents the bottom shelf from rocking on the center divider as you tighten your pocket screws.

After attaching the bottom shelf, mark its center and square up the center divider. Use your countersink bit to drill four holes and secure the bottom shelf to the center divider with #8 x 1 1/4" flathead wood screws.

To attach the back, flip the bench forward so it is lying on its face, flush the back panel to the top of the sides, then drive home the pocket screws. Then use your countersink bit to drill four evenly spaced holes to secure the back to the benchtop, and repeat to join the back to the bottom shelf.

Now break all the edges with some #120-grit sandpaper and you're ready to finish.

For that Store-bought Look

To match my bed, I wanted this bench to have the contemporary finish that, according to Editor Christopher Schwarz, "all the kids love these days." The goal was to have a dark mahogany look with a touch of grain showing

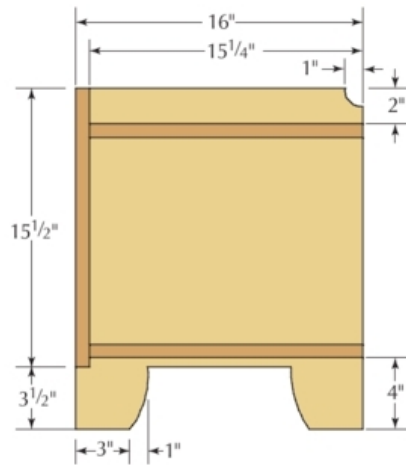

PROFILE

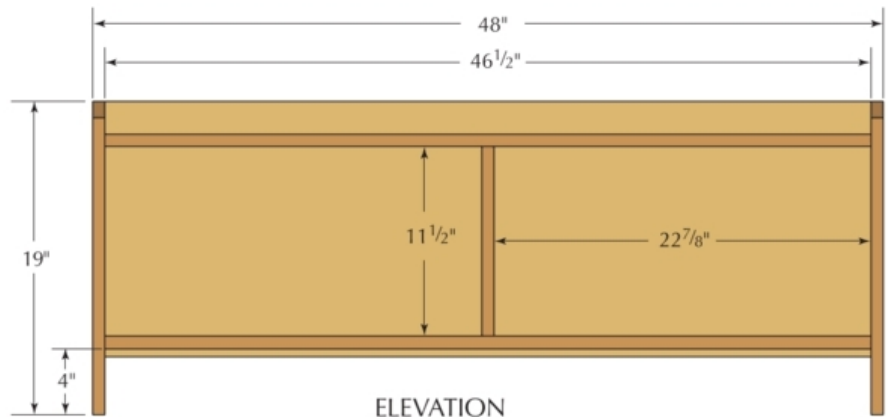

ELEVATION

Storage Bench

NO.	ITEM	DIMENSIONS (INCHES)			MATERIAL
		T	W	L	
1	Benchtop	3/4	15 1/4	46 1/2	Plywood
1	Bottom shelf	3/4	15 1/4	46 1/2	Plywood
1	Back panel	3/4	15 1/2	46 1/2	Plywood
2	Sides	3/4	16	19	Plywood
1	Center divider	3/4	15 1/4	11 1/2	Plywood

through, while still masking the plys on the exposed edges.

It sounds like a lot to accomplish, but heavily thinned latex enamel paint works perfectly. To thin the latex enough to allow a gradual build of color, begin by adding the paint to a cup of water. Once it has reached the consistency of chocolate milk, test the paint on an offcut. Once the consistency seems right, build up two to three coats of paint on your bench, until the wood reaches a rich, dark color but still has some grain peeking through.

When painting with this thinned-down latex, don't start at the corners. When you paint the vertical sides, the paint will inevitably run down and fill in the corners. By not painting the corners first, you eliminate this fun "extra" coat and end up with a more even finish all around. For the exposed edges of the plywood, apply multiple coats (it doesn't hurt to use the extra-thick paint at the bottom of your cup – the plys will soak up a lot).

After that, apply two coats of a glossy wiping varnish, sanding with #320 grit between

the coats. Finally, buff down any remaining dust nibs with #0000 steel wool then apply a coat of paste wax. **PW**

Drew is the associate editor for the web for Popular Woodworking and Woodworking Magazine. Contact him at 513-531-2690 x11008 or drew.depenning@fwmedia.com.

About This Column

Our "I Can Do That" column features projects that can be completed by any woodworker with a modest (but decent) kit of tools in less than two days of shop time, and using raw materials that are available at any home center. We offer a free online manual in PDF format that explains all the tools and shows you how to perform the basic operations in a step-by-step format. You'll learn to rip with a jigsaw, crosscut with a miter saw



and drill straight with the help of our manual.

Visit ICanDoThatExtras.com to download the free manual.

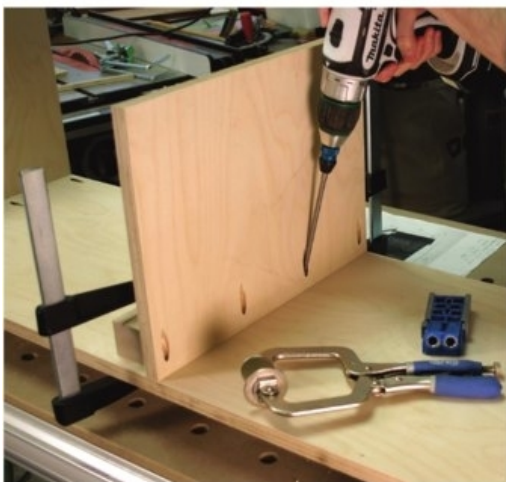

Square with scrap. A clamped block ensures the center divider remains straight as you drive the pocket screws.

TOOL TEST

BY THE POPULAR WOODWORKING STAFF

Veritas Dovetail Saw

New saw design opens the door to hand sawing.

One of the thrills of woodworking is learning a new technique and adding a new skill. Many new skills require a new tool, and the cost of the tool can become a stumbling block. The ability to saw by hand was taken for granted by our grandfathers. One of the reasons for that was the availability of decent tools at affordable prices.

Thirty years ago, there simply wasn't a new, decent quality Western-style saw available at any price. If you wanted to learn how to saw by hand, your best bet was a Japanese saw. These were sharp and usable out of the box, but they cut on the pull stroke instead of the push. Would Japanese cars be as popular as they are if they were only available with the steering wheel on the right?

Small toolmakers have since filled the gap with Western saws made the old-fashioned way, and many a woodworker has since had an epiphany about sawing. It isn't that hard if you have a good tool. But the price for switching on that light bulb in your brain is out of reach for some. Handmade saws that retail for more than \$100 are actually well worth it and a good value—if you know how to use a saw and what to look for when you go to buy one.



Simple connection. A single bolt connects the handle to the spine and blade—a cost-effective solution to a labor-intensive process.



Veritas Dovetail Saw

Lee Valley ■ 800-871-8158
or leevalley.com

Street price ■ \$65

For more information, circle #149 on Free Information Card.

If you've thought about taking up sawing joints by hand, and price has been holding you back, you can now start sawing—or look for a new excuse. Veritas has recently introduced a new dovetail saw that performs nearly as well as any other, and at about half the price.

The key to this is some serious design work with an eye to streamlining the manufacturing process, thus reducing the cost. This isn't value engineering or cheapening a product. It is starting from the ground up with new ideas about making an old tool.

The most obvious difference between this saw and traditional designs is the spine and the way it attaches to the blade and the handle. What appears to be black plastic where brass or steel ought to be is actually a high-tech material composed of stainless steel powder, glass fiber and a polymer resin. The metal gives it heft, the fibers make it stiff and the resin holds it all together.

The spine is overmolded to the blade and to a stainless steel mounting bolt for the handle, making a complicated assembly essentially one piece. A single bolt runs up from the bottom of the bubinga handle, similar to the way a plane tote is attached. When you pick the saw up it feels right; the weight and balance

are what you would expect in a well-made dovetail saw.

The 14-points-per-inch rip blade (made in Japan) is 9¹/₄"-long and .020" thick with .003" of set on each side. The rake angle is 14° and the included angle is 60°. One of the drawbacks to mass-market Japanese pull saws is the induction hardening of the blades; they're brittle and can't be resharpened. Among the Veritas specifications is the hardness; these saws can be resharpened by the owner with a file.

Of course the proof is in the using, and this is a nice saw. It cuts clean, stays on track and is easy to start. It strikes a nice balance between aggressive cutting and leaving a smooth surface. I like it and would recommend it, especially to someone new to sawing.

The price point makes it an easy purchase, and the quality and performance place it far beyond what might be expected of an entry-level tool. Hats off to Veritas for innovative engineering and thoughtful design.

—Robert W. Lang

Metabo Sander Pulls Double Duty

Many woodworkers rely on random-orbit sanders as their primary method to level an out-of-whack glue-up or for smoothing a surface in preparation for finish. To accomplish both tasks adequately, most sanders are made with middle-of-the-road specifications. If your primary interest is fast stock removal, you purchase an aggressive sander. And if a smooth, swirl-free surface is your aim, you'll need a different tool.

Metabo has a new sander that accomplishes both tasks with a single unit. The SXE450 is a double-duty sander. This sander has a setting for aggressive stock removal – a 1/4"-orbit diameter makes quick work of leveling a glued-up panel – and a second setting with an 1/8"-orbit diameter for producing that smooth surface needed for stain. Switching between the two settings is as easy as pushing a button, then turning the sanding pad counterclockwise until it clicks.

This 6" multi-tasker has a 3.4-amp motor with variable speeds up to 8,000 rpm and it

weighs just 5³/₄ pounds. And if oscillating at more than 18,000 orbits per minute (opm) isn't enough, flip a turbo-boost switch and raise the rate to near 22,000 opm.

The Metabo SXE450's integral dust-collection system works great, but as I surfaced a piece of rough pine to see how quickly the job was completed using an aggressive and turbo-boosted setting, I did notice a small amount of dust gathering around the tool's base. A quick look at the filter and I had my explanation. The canister was packed full of pine dust. In aggressive mode, use an external vacuum or plan to clean the washable filter often.

Every once in a while you pick up a tool and it instantly feels good in your hands. Then you pull the trigger and the sound of the tool



SXE450 Random-orbit Sander

Metabo ■ 800-638-2264 or metabo.com

Street price ■ \$214

For more information, circle #150 on Free Information Card.

is equally impressive. That's exactly what I felt with this new, German-made sander from Metabo. Pull the trigger and make a purchase. You'll be rewarded.

— Glen D. Huey

Ridgid's Rock-top Saw

Ridgid now has its version of a granite-top table saw on the market. With the motor mounted inside the cabinet and the saw powered from a 110-volt circuit, the Ridgid R4611 saw is considered a hybrid saw.

Features on this saw are numerous. There's an integrated guard assembly including a spreader, anti-kickback pawls and blade guard. This assembly travels with the saw blade. It is not, however, a riving knife. It's not possible to remove the blade cover or anti-kickback pawls without removing the splitter, so any non-through cuts require a complete assembly removal.

The arbor carriage is a cast, one-piece design and the cabinet-mounted trunions make alignment adjustments easy – loosen four bolts, align, then cinch the bolts. And with the blade/miter slot alignment on our saw out by .011", it was great to have a quick fix.

As parts came from the box, the split-section front rail caught my attention. The two sections are sleeved together and require additional scrutiny to get the two properly aligned when installed. If there's an issue with fence alignment, check that front rail. I had to make slight adjustments to keep the fence

consistently in line with the blade and miter slot.

The Herc-U-Lift mobile base is a nice addition, but is a difficult build and finicky to adjust. An optional pan, fitted with a 4" port, bolts to the cabinet bottom to enclose the base. Of course, dust collection is improved, but the setup is not optimal.

Plan to spend a couple extra hours to get this saw up and running. I found the assembly frustrating because the instructions were a bit lacking in, well, instruction, and the many bolts, screws and washers are difficult to locate when needed, although the packages are marked.

I was a bit concerned about the machine's 1¹/₂-horsepower motor – most hybrid table saws have an least 1³/₄ hp. But after ripping both 4/4 maple and 8/4 jatoba without any



10" Granite Top Table Saw

Ridgid ■ 866-539-1710 or ridgid.com

Street price ■ \$599

For more information, circle #151 on Free Information Card.

issues, my fears were put to rest.

If rust is an issue on your tabletop, or if you simply long for a granite top on your next saw, this machine will do the work. But for my money, I would squeeze a few dollars out of my piggy bank and go for an upgrade.

— GH

Vesper Sliding Bevel Locks Like a Rock

Here's the problem: The best sliding T-bevels stink. Even if you lock them down hard enough to pop a vein, they will still shift out of position in the middle of a project. In our shop, I have tried every brand of sliding bevel, both new and vintage. The ones that lock the best are the sliding bevels made by Chris Vesper of Australia.

These tools use an old patented mechanism that Vesper improved to make the square very difficult to knock out of position. Yes, it will move if you really abuse it, but its grip is stronger than you need for the shop. And that's all that counts. Plus, the blade's locking knob is never in the way – it's smaller than the body of the tool. That is so simple yet so clever.

In case someone is reading this article to you from across the room, you have to take a gander at this tool. It is drop-dead gorgeous in every detail. All the components fit together like a Swiss watch. The stainless steel blade slides smoothly and resists casual bending. The wood infill is perfectly mated in its brass body. The knurling is exquisite.



Vesper Sliding Bevels

Vesper Tools ■ +61 3 5977 8901 or vespertools.com

Street price ■ \$124 to \$211

For more information, circle #152 on Free Information Card.

You can order these bevels with a variety of Australian woods for the infill, including Tasmanian blackwood, lace sheoak and black red gum. The wood you choose and the length of the blade will ultimately determine the price. The bevels are available in three blade lengths: 4", 7" and 10". The prices range from \$124 to \$211.

These are – without a doubt – the best looking and functioning sliding bevels I've ever used. If you work with angles, these will set you straight. — Christopher Schwarz

Craftsman's Router for Light-duty Work

Through the years I've turned my small router (a.k.a. laminate trimmer, trim router or palm router) into my top choice for light-duty edge work of all kinds. A trim router isn't going to hog off scads of waste while it produces a profiled edge – at least not without multiple steps as you work. But for router work that's detail-oriented, a palm router is first-rate.

Craftsman's newest small router is the "Professional 6.5-amp Palm Router" (model #28212). It's a 1 1/4-horsepower tool that handles only 1/4"-shank router bits. (One drawback to making a palm router your go-to router for all tasks is that these tools will not accept 1/2"-shank router bits.) Bit change is achieved via a spindle lock and a single wrench.

This palm router has a soft-start feature to help reduce start-up torque and has variable speeds set between 18,000 - 28,000 rpm that are controlled with a thumb knob that's within easy reach as you hold the tool to work – as is the rocker-style on/off switch.

Out of the box, the buckle-style cam lock had to be adjusted to keep the motor (and as a result the bit), from creeping in its base during operation. But once tightened, the tool held its position.

This kit includes an extra base that features twin joystick handles that are comfortable to use. The additional base adds some width to the router and trumps the too-small base that comes attached to the router. Because this router is a bit tall and top-heavy, I suggest switching bases from the get-go, unless you're working in tight quarters. Also, guide bushings are not usable with either base, which limits the tool's utility.

A couple nice features that Craftsman added to this router are an 8' cord and a live-tool indicator light to remind you that the tool is plugged in. But I'm not impressed with the tool's two built-in, clear blue ambient LEDs for illumination. The view areas of the bases are so small that the light doesn't add significantly to the ease of view.



Professional 6.5-amp Palm Router

Craftsman ■ 800-549-4505 or craftsman.com

Street price ■ \$120

For more information, circle #153 on Free Information Card.

All in all, this router should be relegated to a back-up role in a busy woodworking shop, but it could take the lead for most homeowner uses. **PW**

— GH



Vintage cabinet, special wood. Originally designed for the Gamble house a century ago by Charles and Henry Greene, this small cabinet is worthy of a prominent place in any home.

Greene & Greene MEDICINE CABINET

BY ROBERT W. LANG

Humble origins but a distinguished pedigree combine in the ultimate Arts & Crafts medicine cabinet.

This cabinet caught my eye on my first visit to the Gamble house. I had an hour to kill before the tour began, and spent that time in the bookstore, which is housed in the original garage. Charles and Henry Greene added nice details to every facet of their work, even places the owners would rarely, if ever, see. The Gamble garage is a very nice garage.

At the back of the building is a small restroom provided for the chauffeur. That is where the original version of this cabinet has lived for almost 100 years. A picture of the original cabinet is on page 68 of the November 2008 issue of *Popular Woodworking* (#172).

I was taken with the form and proportions. The case is very simple, with curved forms on the top and bottom of the sides, and a wonderfully proportioned door. I promised myself to someday build a version.

I had a small amount of bird's-eye cherry that I had been hoarding for several years. There wasn't enough of it to build a large piece of furniture, but there was too much for a small project, so it sat in my garage. The day after completing the drawings for this project I tripped over the precious pile of cherry and decided it was time to use it. Some quick



Quick custom jig. The dado-routing jig is made by clamping the two guide rails on either side of a shelf. The top-mounted bearing on the router bit then cuts the proper-width dado without measuring or fussing.

measurements revealed that I had just enough to build this cabinet.

Details Make Simple Into Sublime

My widest piece of cherry had enough material for the two carcass sides and the door panels. I took the piece intended for the panels, resawed it at the band saw, and set it aside while I worked on the case.

I printed full-size paper patterns of the top and bottom side profiles, and adhered them to



Stop action. A pencil mark indicates the end of the dado, and because the router will leave rounded ends, I stop just short of the mark.

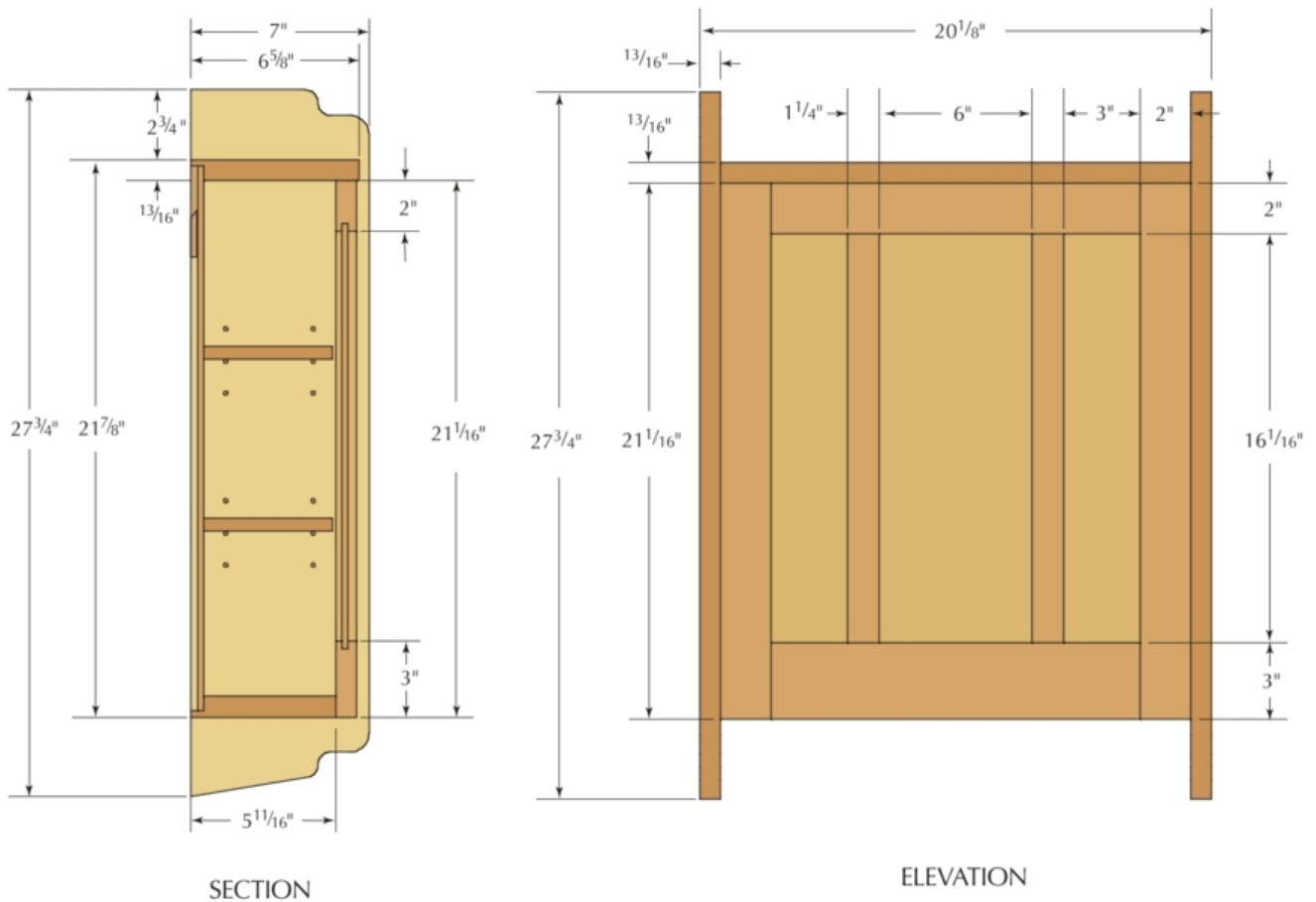

Greene & Greene Medicine Cabinet

NO.	ITEM	DIMENSIONS (INCHES)			MATERIAL	COMMENTS
		T	W	L		
□ 2	Sides	13/16	7	27 3/4	Cherry	
□ 1	Cabinet top	13/16	6 5/8	19	Cherry	
□ 1	Cabinet bottom	13/16	5 11/16	19	Cherry	
□ 2	Shelves	5/8	5 1/8	18 7/16	Cherry	
□ 4	Back boards	1/4	5	21 3/8	Cherry	Shiplapped
□ 2	French cleats	1/4	2	18 1/2	Poplar	
□ 2	Outer door stiles	13/16	2	21 1/16	Cherry	
□ 2	Inner door stiles	13/16	1 1/4	18 9/16	Cherry	1 1/4" tenon both ends
□ 1	Top door rail	13/16	2	17	Cherry	1 1/4" tenon both ends
□ 1	Bottom door rail	13/16	3	17	Cherry	1 1/4" tenon both ends
□ 1	Center door panel	1/4	6 1/2	16 9/16	Cherry	
□ 2	Outer door panels	1/4	3 1/2	16 9/16	Cherry	

the sides with spray adhesive. These patterns are available online at popularwoodworking.com/apr09, along with a SketchUp model of the plans.

I held the two sides together with double-stick tape, cut the profiles at the band saw, and cleaned up the cuts with a rasp followed by a scraper. Working on both sides at the same

time ensured a good match, and cut the time for making the sides in half.

The top and bottom of the case fit in stopped dados. I made a jig to guide my router for cutting the dados by clamping two pieces of scrap to each side of the top. I then screwed a third piece at a right angle to the other two to register the router on the front of the case side.

Using a 5/8"-diameter mortising bit with a bearing mounted above the cutter, I made a test cut in some scrap, then clamped the jig to the side and routed a 1/4"-deep dado, stopping 1/2" short of the width of the finished top and bottom. The top overhangs the door, and the bottom sits behind the door, so I laid out the exact dimensions before cutting the dados.

I squared off the ends of the dados with a chisel, and cut a notch in the front edge of the two horizontal pieces. The only other joinery on the case is a 1/2"-wide by 1/2"-deep rabbet for the back panels. I used a rabbeting bit in a hand-held router, cutting the rabbet along the entire length of the top and bottom. The rabbets in the sides stop where the rabbets meet the dados.

Before assembling the case, I drilled 3/16"-diameter holes for the two adjustable shelves. I brushed the end grain of the top and bottom with yellow glue, and also coated the end grain inside the dados. After waiting 10 minutes, I brushed a second coat of glue inside the dados, and clamped the case together. Sizing the end grain like this makes for a stronger glue joint.

A Well-made Door

The door is rather wide, and the components of it are rather thin, so I paid careful attention to the joinery. The first step was to cut a 1/4"-wide by 5/16"-deep groove on one edge of the outer stiles and the top and bottom rails. The narrow intermediate stiles were grooved on both edges.

I made the grooves by passing the edges of the pieces over a stack dado set at the table saw, running the grooves all the way along the edges of the stock. The groove is located 1/4" in from the back of the door making it offset by 1/16" in the 13/16" material.

This meant all the grooving had to be done with the face against the saw fence, but from that point on there was no confusion regarding which was the front and which was the back on the door parts; the fat side was out and the skinny side was in.

I set up the hollow-chisel mortiser with a 1/4" chisel and with the face of one of the stiles against the machine fence, I adjusted the fence so the chisel was aligned with the groove. I set the depth of the chisel to cut 15/16" deep from the edge of the stiles and cut the four mortises in the outer stiles. I wasn't sure how my material would behave, so I kept the ends of the mortises 1" away from the ends of the stiles to keep the ends from blowing out.

The top rail is the same width as the outer stiles, so the same machine settings could be used to make the mortises for the intermediate stiles. The lower rail is wider, so I had to readjust the depth of cut before cutting the last two mortises.

I used a wheel cutting gauge to define and

mark the shoulders of the tenons. The fine cut left by the gauge is actually the finished edge of the shoulder. I made the cheek cuts for the tenons on the table saw using a tenoning jig that rides the saw's fence, and used the sliding crosscut table to cut the shoulders.

To avoid over-cutting the tenon shoulders, I left a little bit of material on the inside corner. I used the cutting gauge to remove this and refined the fit of the tenons with a paring chisel and a rasp.

The groove for the panels continues beyond



Finish by hand. A few cuts with a chisel complete the end of the dado for the top and bottom shelves. The front edge of the shelf is notched and ends 1/2" past the end of the dado. The notch is cut by hand with a dovetail saw.



Dual-purpose tool. The cutter on the gauge removes the remaining material where the tenon cheek and shoulder meet. After scoring it with the gauge, pare with a chisel.



Drop-in measurement. With the adjustable square sitting on top of the groove in the stile, the blade is bottomed out to obtain the exact measurement for the depth of the groove.



Easy transfer. Setting the end of the square's blade against the shoulder, and marking with a pencil at the bottom of the stock, transfers the depth of the groove to the haunch in the tenon.

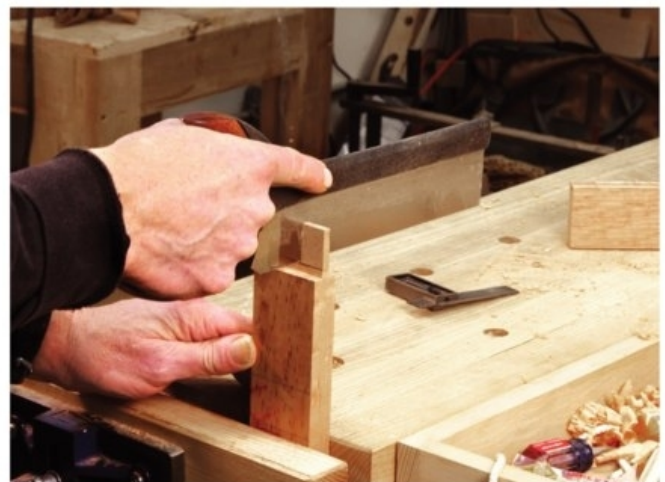

Faster by hand. Cutting the haunch by hand is faster than setting up to make these cuts by machine. Only the end of the haunch will be seen in the finished door, so this is a good place to practice making cuts by hand.

the tenons, so I needed to cut a haunch on the sides opposite the groove in the top and bottom rail tenons. Using my adjustable square, I set the stock on the edge of a rail, and dropped the blade into the groove.

This provided the exact dimension for the haunch without measuring. I then placed the end of the square against the shoulder and marked the cut line. After marking the width of the haunch, I made the cuts with a dovetail saw. In addition to filling in the groove, the

haunch serves to keep the faces of the rails and stiles aligned.

The Focus of Attention

The panels of the door presented an aesthetic problem. I started with one piece of material, $1\frac{3}{16}$ " thick and 7" wide. I resawed it down the middle and planed the two pieces to a finished thickness of $\frac{1}{4}$ ". My original plan was to use one piece for the center panel, and rip the other in half for the two outer panels.

The grain pattern was straight on one half of the panel, but the other half contained a cathedral arch at the bottom. The three panels together wouldn't have looked right with an arch on the left, an arch and straight grain in the center, and straight grain only on the right-hand side.

My solution was to bookmatch the panels, so I flipped one piece over, and glued the straight-grain portions together in the center. After the glue dried, I made two rip cuts in the panel, leaving a wide, straight-grained section and two narrow pieces with mirror-

image arches in the lower corners.

I assembled the door in two stages. First I put the center panel in place, and glued and clamped the two intermediate stiles between the top and bottom rails. I let this sit in the clamps over a long lunch, and then inserted the outer panels, brushed glue in the mortises of the stiles and completed the assembly.

I did this to help keep the door square. The glue on the interior joints had set, and held the top and bottom rails in position as I glued on the outer stiles. I only had to keep an eye on a few joints rather than wrestling with several clamped in opposing directions.

The Search for the Right Hardware

One of the distinctive features of this cabinet is the position of the door, set back from the front of the case $\frac{1}{2}$ ". This looks cool, but it presents a problem: There isn't any room for the barrel of standard butt hinges. The original solution was to use hinges known as "parliament hinges" commonly found on casement windows of the period.

This isn't the type of hinge likely to be found at the local hardware store, and a search of the Internet led to one source that had the correct size and configuration. The only finish available was polished brass, so when the hinges arrived, I soaked them overnight in lacquer thinner, then scrubbed them with an abrasive pad.

With the finish removed, I put the hinges inside a plastic storage container with an airtight lid. Putting on my respirator, goggles and rubber gloves, I poured a couple ounces of strong ammonia into a small cup, put that in the container along with the hinges then sealed the lid. In about two hours, the brass had the patina I was looking for.

I set a hinge on the cabinet side with the barrel even with the edge and marked a line at the bottom of the leaf. This gave a reference for the edge of the hinge mortise on the edge of the door.

I set up a small plunge router with a $\frac{1}{2}$ "-diameter straight bit, and set the fence so that the edge of the bit was just inside the line of the leaf edge. To set the depth of cut to the thickness of the hinge leaf, I first leveled the bottom of the bit with the base of the router. Then I placed the hinge leaf between the depth stop and the adjustment rod. Lowering the rod set the cut depth to the exact thickness.

I placed the door in my bench vise with the edge flush with a small box. This prevented the router base from tipping as I cleared the



Double duty. The haunch fills the panel groove on the outer edges of the door. It also will keep the stile and rail faces aligned if the wood warps.



Two step glue-up. The center panel is put in place and the intermediate stiles glued between the top and bottom rails. After letting the glue cure, the outer panels are inserted, and the stiles are glued to the rail ends.

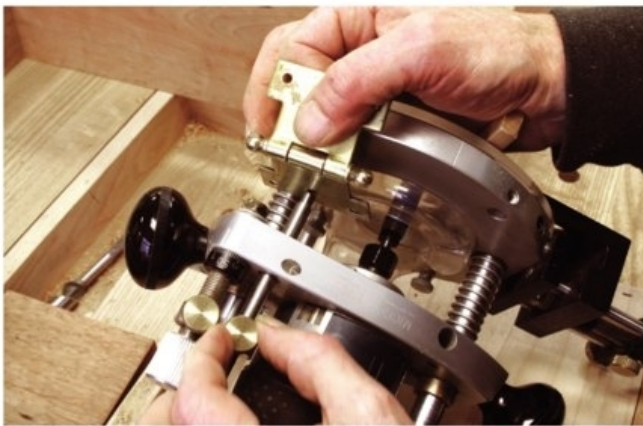

Better than measuring. Use a leaf of the hinge to set the depth stop on the plunge router. Set the bottom of the bit flush with the router base, then set the depth stop to the hinge. Plunge the router to the stop and you're set.



Support group. I clamp the door in my vise with the top edge of the door even with the top of a wood block. The fence on the router sets the distance for the hinge mortise, and the base of the router can't tip.

waste from the hinge mortise. A little work with a chisel cleaned out the rounded corners left by the router.

Because the barrels of the hinges are in front of the door, the door swings in a different arc than it would if hung on standard butt hinges. This allowed a narrow gap on the stile opposite the hinges, and I only needed to plane a slight back bevel to fit the door. The hinges are simply screwed to the side of the cabinet; no mortise is needed.

Getting a Handle on Things

I had hoped to use a casement window latch to hold the door closed, as had been used on the original. A second look at the photo of the original revealed the latch actually came past the edge of the case side, with the strike plate extending about $\frac{1}{4}$ " beyond the cabinet. I wasn't happy with that detail, and searched in vain for a casement latch that looked like the original without the plate sticking out.

In a moment of Krenovian inspiration, I took a scrap of cherry, $\frac{13}{16}$ " x 1" x $1\frac{3}{4}$ ", and sketched a profile on the side. I carefully made some rough arced cuts at the band saw, then smoothed the profiles with the round side of a rasp. I attached the handle to the door with a screw from behind, slightly below the center of the stile.

To keep the door closed, I used a small double-ball catch placed near the upper corner of the door. The bottom of the door stops on the bottom shelf. The shelves sit on 5mm-diameter pins and to keep the pins out of sight, I used a $\frac{3}{8}$ "-diameter core box bit to rout two grooves in the bottom edge of each shelf.

The back consists of four $\frac{1}{4}$ "-thick x 5"-wide pieces, with a rabbet on adjoining edges. These shiplapped pieces are held to the top and bottom of the cabinet with #6 x $\frac{5}{8}$ " screws. After attaching the back, I screwed a $\frac{1}{4}$ "-thick French cleat across the top of the back to hold the cabinet to the wall.

My favorite finish for cherry is several coats of Danish oil, applied with a rag and wet-sanded with a nylon abrasive pad. I planed and scraped all of the cabinet parts before assembly, to keep sanding to a minimum. Before finishing, I hand-sanded with #240-grit Abranet, then sanded again with #320-grit, leaving a smooth surface.

I wanted to warm and darken the color so I used Watco "Medium Walnut" for the first three coats of finish. I flooded the surface for the first coat, and kept the surface wet for 45 minutes, adding oil to any areas that dried out. Then with a clean rag, I wiped the surface dry, and left things alone for a couple hours.

The second coat can be applied the same day as the first, but I only left it wet for 15 or



Final cuts. The router leaves a flat bottom and a straight back edge to the hinge mortise. The rounded corners, however, need to be removed with a chisel. Knifed-in layout lines provide a reference for the chisel.

20 minutes before wiping it dry. This and subsequent coats were left to dry overnight. Three coats of "Natural" Watco followed the first three coats, and after 48 hours of drying, I applied a coat of paste wax. The completed cabinet is destined for a nicer home than the back of the garage. **PW**

Bob is a senior editor of this magazine and the author of "Shop Drawings for Greene & Greene Furniture" (Fox Chapel), available from his website: craftsmanplans.com. Contact him at 513-531-2690 x11327 or robert.lang@fwmedia.com.

Supplies

Hardware Source
877-944-6437 or
hardwaresource.com

2 ■ solid brass parliament hinges, $2\frac{1}{4}$ " x 3"
#817000, \$12.97 each

Lee Valley
800-871-8158 or
leevalley.com

1 ■ double ball catch, 38mm x 7mm
#00W12.00, \$1.40

8 ■ steel shelf supports,
#00S10.01, \$3.70 pkg. of 50

Prices correct at time of publication.

Online EXTRAS

To download full-size patterns of the cabinet side profiles, and a SketchUp model of the project, visit:

popularwoodworking.com/apr09

Three Ways to Make EDGE JOINTS

BY ROBERT W. LANG, GLEN D. HUEY & CHRISTOPHER SCHWARZ

By hand or power? With a spring joint or not?

One of the most important joints in woodworking is the edge joint. Without it, our projects would look like they had been built from narrow popsicle sticks.

The joint bewilders many amateur woodworkers—perhaps because there are so many ways to go about it. Which method is best? Which tools are best?

The senior staff of *Popular Woodworking* rarely agrees on anything (except the pizza place at which we sometimes eat lunch). And making edge joints is no exception. We do, however, agree on one principle when it comes to edge joints: You aren't going to get consistent results by making your edge joints with a table saw blade.

During the last decade or so we have tested a dozen table saw blades that claim to give you rips that are clean enough for an edge joint. Perhaps that is true if your work is on a job site, if you are working in easy-to-compress softwoods, or if you are a fanatic about keeping your saw exquisitely tuned. But we have not found these saw blades to give us results that are 100 percent satisfactory.

And so we look to other tools and machines to create edge joints that result in seamless seams and maximum glue adhesion.

Understanding History

This joint has always made woodworkers edgy (sorry). Early written accounts of making edge joints would tout a variety of approaches as the best to ensure the finished panel stayed together.

Some accounts recommended loose splines. Some recommended using a tongue-and-groove joint. There was even a special kind of nail that could be used for joining edges. More modern methods of reinforcement include dowels, biscuits, Festool Dominos and pocket screws.

However, we contend that if you have two surfaces that will mate perfectly then you don't need additional

reinforcement. A well-made glue joint is stronger than the wood surrounding it.

Another area of confusion: Other early accounts recommend using a "spring joint" when gluing up a panel. A spring joint is when the edge joint has a small gap (only a few thousandths of an inch) in the middle of the seam. When you clamp across the middle of the panel, it closes the entire seam.

The advantage of a spring joint is that you use fewer clamps to make your panels. Also, if your stock is a little wet, a spring joint can keep the ends tightly together as the stock dries out (end grain loses moisture much more rapidly than face grain).

Some opponents of spring joints say that the gap introduces some stress into the panel that could (in time) cause the joint to open. Other opponents say that spring joints are simply a waste of good shop time.

In our shop, the opinion is divided.

Publisher Steve Shanesy and Senior Editor Robert W. Lang don't use spring joints. And so we're going to show Lang's approach, which uses a powered jointer without any special setups to introduce a spring joint.

Senior Editor Glen D. Huey likes spring joints as a way to reduce the number of clamps he needs to use. He figured out a fairly simple jointer setup and hand trick that makes spring joints an easy thing to do on the powered jointer.

And then there's me. I like spring joints and I like making them using handplanes. And so I'm going to show you how to make an edge joint using historical methods I've dug up from the old books.

So step away from your table saw for a moment and take a look at these three time-tested techniques and decide which one would be best for you.

—Christopher Schwarz

Jointer – No Spring Joint

My approach to edge joining comes from my training in production shops, and my philosophy that a joint under tension increases the chances of failure in the future. I don't use a spring joint, and I run edges over a well-tuned jointer just before gluing. There isn't anything

romantic or inspiring about my approach, but it works well, and it doesn't take long.

I'm a bit persnickety about machine setups, and I get cranky if I have to remember what area of a machine is off a little, and in what direction that offset is. In truth, I have trouble remembering things like that, so it's easier to have the jointer knives even with the outfeed table and the fence square.

I select wood for panels and tabletops based on appearance. You can't convince me that there is an advantage to alternating growth rings, or arranging the boards so they will be easy to plane later on. The goal is to make a pieced-together board look like it grew that way. If the material is prepared correctly I don't worry about it warping, and if I need to fuss a little when doing the final smoothing, that's OK.

This is an area where mastery of the funda-

mentals is the key to success. Dead-flat boards with straight and square edges are easy to put together. Glue them together on a flat surface and it can actually be an enjoyable, relaxing experience. If the boards are straight and the thickness consistent before gluing, there is little to be done afterwards.

I crosscut the rough lumber to about the size I need, but when I surface, edge and rip I'm thinking WAP and TAP – "wide as possible" and "thick as possible." This leaves some margin for me to work around defects or ugly spots without starting over. I try to keep parts from a single board together to make it easier to match color and figure.

There may have been a time when a spring joint made sense, especially if the moisture content of the wood was too high. In this day and age, it makes as much sense as collar stays and celluloid dickies.

— RL



1 Best face forward. These three pieces came from the same board, and I mill them about $1/16$ " thicker than I need. I also rip the boards wider – overall the three are about 1" too wide and 3" or 4" too long. When I'm happy with the arrangement visually, I mark part of a triangle on the faces with a lumber crayon.



2 One in, two out. I run each edge to be glued over the jointer, alternating the faces to compensate for any small error in the jointer fence. Keeping track is simple. On the first edge the marked face goes toward the fence. On the next piece, the marked face goes out on both edges and on the last piece the marked face goes in.



3 Check before gluing. I place the boards across small strips of wood to make it easier to align the faces, and to keep glue off the benchtop. I make sure these pieces are straight and exactly the same size. If the bench is flat, the support strips equal in thickness and the edges of the parts true, I can squeeze the parts together by hand and not see any gaps.



4 Edges up. I flip the first two pieces up on edge and apply a single bead of glue. I don't need to apply glue to both pieces or spread it around. That happens automatically when the parts are clamped together.



5 No wrestling. It doesn't take much pressure to clamp the boards together. My left hand holds the boards down on the support strips to keep the faces in line. A small amount of pressure from the clamp will close the joint for most of the length – if the edges are straight.



6 Clean up immediately. I scrape off the excess glue, then wipe with a damp rag. If the glue bead dries on the surface, it slows down the drying process, and traps moisture from the glue in the joint. I think it makes a weaker joint.



7 Good to go. The finished glue line is nearly invisible. After letting the glue dry for an hour, the clamps can be removed. Complete curing takes longer, so I let the assembly dry overnight before further surfacing. If I do it right, it only takes a few swipes with a card scraper to clean up the panel.

Jointer – With Spring Joint

I prepare my edges with a jointer, but I also like a small spring in my joint. Because I'm not a handplane aficionado, I turn to a machine. As a result, I have to bend the rules.

In most articles on setting jointer knives you're instructed to use a dial indicator to set the knives perfectly level and in line to the outfeed table. That's bunk.

While you do need to set the knives level to one another, alignment with the outfeed table is optional. I set my knives so there is .030" of slope over the 8" blade. The end of the knives closest to the operator are below the outfeed table by .015". At the back they are .015" above the outfeed table.

With the knives below the outfeed table, you'll get a taper if you transfer hand pressure to the outfeed table as soon as there is ample surface to do so. That's another rule I choose not to follow given my blade arrangement!

When edge jointing, I keep my downward-pressure hand at the center of the board. As the board runs over the knives it climbs slightly above the outfeed table. At the center of the board my pressure transfers to the outfeed table and the slight tapering effect completes the cut. Bingo, a spring joint.

And don't worry about flatness when face

jointing. Because a jointed face is not the final surface when milling for thickness, any small variations are erased at a planer. And if you're worried about the small bevel on the edge of a 3/4" board, you're looking at less than a .003" variation.

Bottom line: I can dial in my spring joint by adjusting my fence position along the blades. When everything works as planned, I need only one clamp for most panel assemblies, but I generally use two. (To see how this process works for faces and edges, go to popularwoodworking.com/video.) —GH



1 Bust the myth. Even if your jointer knives are set out of parallel to the outfeed table, sloped .030" over the 8" knife and set .015" below the outfeed table on the end closest to the operator, you'll still gain a flat surface on the face of your stock because the knives are a straight edge. On a standard 3/4" edge, the variation from side to side is a negligible .003".



2 Hand placement is critical. After the knives are adjusted, if you transfer your hands to the outfeed table as a cut is made, you'll get a tapering cut on the edge. With this setup you need to place your hold-down hand at the center of the board. As the cut is made the board rides up the higher outfeed table until your center-placed hand transfers the pressure to the outfeed side. Always place your pressure at the center of the board. Note: The guard has been removed for clarity.



3 Up, up and away. Here you can see how the piece rides off the outfeed table as the cut progresses. If the resulting spring is too large, simply slide the fence back to decrease it. (Your fence position will vary with the board's length.) After a couple passes you'll find the sweet spot where the cut delivers the appropriate bow for a properly sprung joint.



4 It happens automatically. As you move through the cut with your pressure placed at the board's center, the transfer onto the outfeed table will happen in the middle of your pass. The transfer is gradual, so don't expect a quick "slap" as the end returns to the table. With the transfer of downward pressure onto the outfeed table complete, a slight taper is created over the remaining length of the workpiece.



5 Keep it thin. The idea is to create a bow or spring in the board that allows the ends of the joint to be tight as the center gap is closed under clamp pressure. If you create a gap that's too large, the pressure at the center of the board could become overly strong and cause stress at the glue line. And you don't gain anything if the bow is too light. I find a sweet spot where a single sheet of paper slides while both ends are in contact with the jointer bed. Another test is to place no more than a playing card between two board edges as you dry-fit the panel.

Handplanes

Though I first learned to prepare edge joints by machine on a powered jointer, I prefer to do it by hand whenever possible. When I'm working for myself and time isn't a concern, I'll use the pure hand-tool methods shown here. It's a bit slower than the power-tool methods, but I enjoy it immensely.

When every second counts, however, I'll prepare my edges on a power jointer and then use a jointer plane to introduce the spring joint. You can mix and match the hand and power methods any way you see fit.

Here are a couple details and subtleties of my process. Though I use a scrub plane to dress my rough edges, you can also use a table

saw, band saw, drawknife or a hatchet for the coarse removal of material.

Also, the cutter in my jointer plane has a very subtle curve on its edge. This allows me to correct an out-of-square edge by shifting the plane left or right on the edge of the board. But the curve is not so pronounced that it produces a curved edge on the board. The edge looks flat to a try square.

You can read more about this process in the August 2005 issue (#149) of *Popular Woodworking* in an excellent article by David Charlesworth titled "Learning Curves." And you can find it online at popularwoodworking.com/apr09. —CS



1 Gauge your width. I use a panel gauge to scribe the final width on my boards. Scribe the width on both faces of the board.



2 Rip with a plane. I use a scrub plane to work down to the line left by the panel gauge. Use short choppy strokes and each pass can remove $1/16$ ". I reduced this board by 1" in width during one pop song on the radio.



3 Joint and check. Dress your edge with a jointer plane, then use a square to confirm that your edge is true to one face of the board.



4 Spring the center. Here's the fun part. Joint the edge, but begin the pass about 5" in from the end of the board and lift the plane off about 5" from the other end of the board. This is called a "stop shaving" because it doesn't run the entire length of the board. One pass (or two) should be all you need, depending on how deep your cutter is set.

5 Do they mate? With one edge spring jointed, put the board's mate on top of the first board. Wiggle the top board at the end. If you can feel drag at the ends you have a spring joint. If the top board pivots easily at the center you have a hump in the middle of one (or both) edges and you need to try again.



6 Results. With small panels (up to about 36" long) I can get away with using one clamp in the center. Larger panels will require clamps on the ends of the panel as well. **PW**



Gentle curves and elegant details provide a place to get work done in style.

Providence Writing Desk

BY MARIO RODRIGUEZ

A friend of mine recently moved into a small apartment in Providence and needed a place from which she could pay bills, do paperwork and park her computer. But the apartment is small, so the desk would be very visible. In addition to being functional, it had to look good. Needless to say, I've been looking at a lot of desks lately. And I came up with a streamlined design that has a little class; plus it fits her tastes and her space.

The design of this desk was inspired by the clean lines of Austrian Biedermeier furniture from the period 1815-1850, which preceded and influenced the popular Art Deco style. Biedermeier furniture copies the designs and elements found in both classical furniture and architecture: columns, arches, entablatures and graceful tapering legs.



Elegant details. Simple details combine to provide an elegant yet understated look.

The desk is compact, measuring 22" deep x 36" wide x 29³/₄" high and features slender saber-shaped legs, punctuated with a small bead around each ankle and another wrapping around the desk, just below the two drawers. The generous inset dovetailed drawers are fitted with turned knobs.

The desk has a center partition that divides it in two and sits upon the drawer web (or frame). The drawers ride on the web and are guided into the interior of the desk.

In this article, I'll concentrate on the construction of the desk and only briefly mention the making and fitting of the drawers because the topic was recently covered in the February 2009 issue (#174).

Selecting the Stock

I chose mahogany for its warm color, generally mild grain and wonderful working properties. It's a wood that ages well and develops a rich patina over time while surviving the inevitable nicks, dents and unintentional abuse that is the fate of furniture.

Soft maple is a good choice for the secondary wood used to make the drawer parts (sides, back and bottom), web and guides. It's strong enough for the job, machines well and is easily worked with hand tools. It also provides a nice contrast to the deep color of the mahogany. I pulled some 8/4 stock for the 1³/₄"-square legs, 4/4 for the skirts and top and 4/4 maple for the drawers and web frame.

After milling and squaring the leg stock

to 1³/₄" and drawing the template pattern for the legs, trace the outline onto the leg blanks. Make sure to orient the outlines correctly. This is crucial to the proper placement of the mortises.



Long as I can. To maximize the length of the tennons in the rear legs, the ends are mitered.

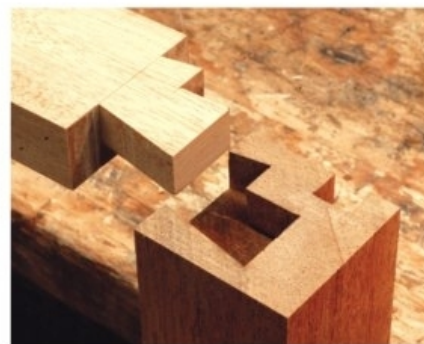

On the side. The upper front rail is horizontal, and joins the tops of the legs with a carcass dovetail joint.

With the outlines drawn on the leg blanks, lay out the mortises. Those on the two rear legs are identical, but the right and left front legs, which are connected by the upper and lower rails that span the front of the desk, require two very different joints. The lower rail is connected by a horizontal mortise-and-tenon joint. The upper rail is attached to the leg by a carcass dovetail joint, a large single dovetail set into the top end of the leg. It maintains the critical dimensions of the desk, compensates for the smaller, weaker mortise and tenon of the lower rail, and also provides strength in case the feet of the table are forced apart. This joint should be cut by hand.

The groove for the ankle bead is cut with a 1/4"-wide dado while the leg is still square. This is easy enough when using a crosscut fence fixed with a stop-block. However the depth of the dados is not the same all around. On the back sides of the leg the dado is cut to 5/16" deep. On the face or front sides, it's cut to 3/4". This difference produces uniform projection of the ankle bead when it's attached to the leg.

I milled the material for the apron parts and the lower front rail, which is grooved to accept the longitudinal rails, and cut them to length. Because the legs were only 1 5/8" (at the top), there wasn't going to be a lot of room



First things first. Before cutting the legs to shape, the dados for the bead are cut at the table saw. The dados on the back and inside are not as deep as on the front and outside.



All things being equal. After shaping the leg, the dados should all be the same depth. I use a simple gauge block to check the dados and adjust as necessary.

for the tenons. I decided on a 3/8"-thick tenon, shouldered on only one face. I was able to make them 1 1/4" long, but only if I mitered them.

I made all the shoulder cuts on the table saw for the best results. Then I cut the cheeks on the band saw. I always cut them just a little fat, so after a light adjustment with a shoulder plane, they fit nice and tight. Because I cut the leg mortises on a slot mortiser, they had rounded ends. Instead of squaring the mortises, I chose to round the tenons with a rasp and coarse sandpaper. The final step was to miter the ends of the tenons, so they would

extend as far as possible into the mortises.

After the mortises and the dados for the beading are cut, the legs can be shaped. The curves in the legs should be carefully cut on the band saw, leaving the outline intact.

Cutting the outline on one side inadvertently removes it from the adjoining, perpendicular side, so it has to be re-drawn on the un-cut side, or the cut-offs (containing the outline) from the first side can be temporarily reattached with tape.

After cutting out the legs, verify the depth of the ankle dados and the location of the mortises. If everything checks out, the legs can be cleaned up and smoothed with a lineup of hand tools, starting with the spokeshave, progressing to a scraper and finishing up with #220-grit sandpaper.

When the beading is attached to the leg, it should be firmly seated into the dado and project only 1/8" (the bead's radius). For proper registration the depth of the dado should be exactly the same all around the ankle. To ensure this critical dimension, I used a small wooden gauge.

I milled the bead on the router table then cut it free, forming a delicate strip of moulding measuring 1/4" by 5/16". This moulding is far too slender to cut with power tools, so I cut the lengths into small 2" pieces using a 16 teeth-per-inch gent's saw.

I mitered the small pieces on a horizon-

Providence Writing Desk

NO.	ITEM	DIMENSIONS (INCHES)			MATERIAL	COMMENTS
		T	W	L		
□ 1	Top	3/4	22	36	Mahogany	
□ 4	Legs	1 3/4	1 3/4	29	Mahogany	
□ 1	Rear apron	3/4	4 1/2	33 1/4	Mahogany	1 1/4" tenon both ends
□ 2	Side aprons	3/4	4 1/2	19 1/4	Mahogany	1 1/4" tenon both ends
□ 1	Upper front rail	3/4	1 5/8	33	Mahogany	1 1/8" dovetail both ends
□ 1	Lower front rail	3/4	1 5/8	32 1/4	Mahogany	3/4" tenon both ends
□ 1	Drawer divider	3/4	3	2	Mahogany	1/4" dado across back
□ 2	Drawer fronts	3/4	3	14 3/8	Mahogany	
□ 1	Beaded trim	1/4	5/16	24	Mahogany	See note*
□ 1	Beaded trim	1/4	1/2	144	Mahogany	See note*
□ 1	Rear upper rail	3/4	2	30 3/4	Mahogany	notched around legs
□ 4	Drawer sides	3/8	3	18	Maple	
□ 2	Drawer backs	3/8	3	14 3/8	Maple	
□ 2	Drawer bottoms	1/4	18 1/4	14	Maple	
□ 1	Drawer partition	3/4	3	18 3/4	Maple	1/4" tongue one end
□ 1	Lateral rail	3/4	1 5/8	30	Maple	notched around legs
□ 2	Longitudinal rails	3/4	2	18 1/8	Maple	1/4" tongue both ends
□ 1	Longitudinal rail	3/4	4	18 1/8	Maple	1/4" tongue both ends
□ 4	Drawer guides	3/4	7/8	18 1/2	Maple	

* Mill profile for beaded trim for legs and below drawers from wider piece and cut to fit lengths

Online EXTRAS

For additional drawings and step photos of building this project, go to:

popularwoodworking.com/apr09

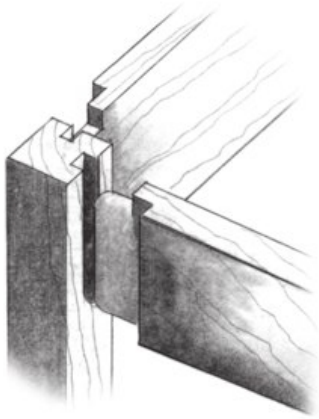

APRON TO BACK LEG JOINERY

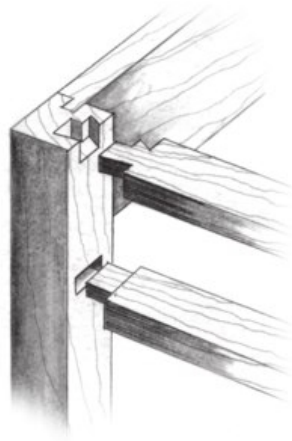

RAIL TO FRONT LEG JOINERY

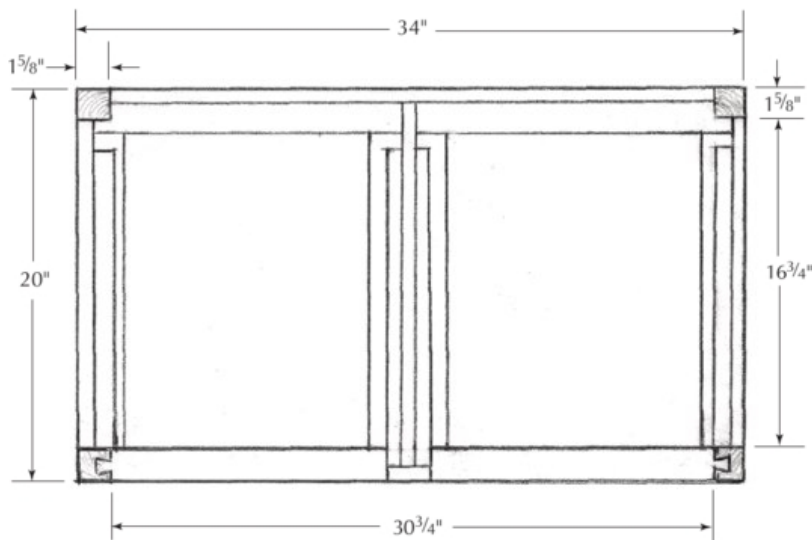

PLAN BELOW TOP



LEG PATTERN
1 square = 1"

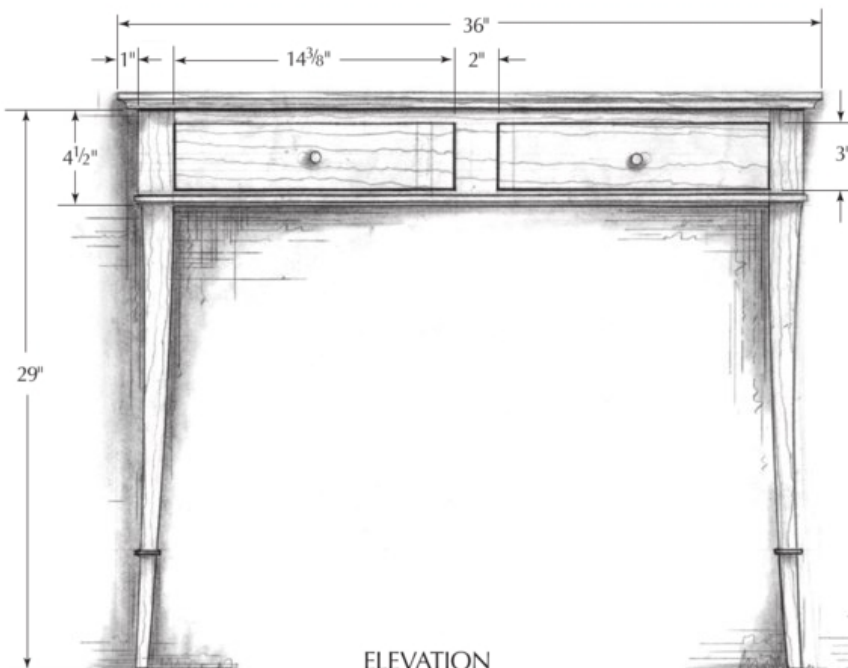

ELEVATION

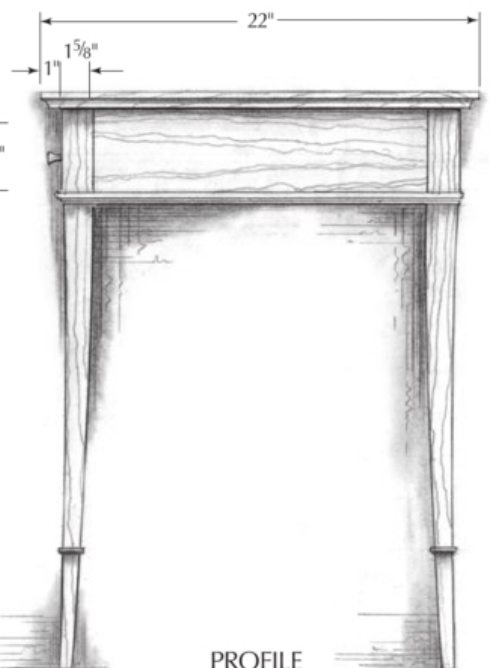

PROFILE

tal belt sander fitted with a miter jig. Using this jig and sanding away material, instead of planing it, allowed me to easily “sneak up” on a clean, perfect fit. Of course, these small pieces can also be trimmed and fitted with a block plane.

When fitting the bead, work from the front or leading corner of the leg towards the back. That way the most visible miters will be tight and any small error can be hidden at the back of the ankle. I glued the pieces in with a small amount of carefully applied yellow glue, held them in place with strips of masking tape, and quickly wiped away any squeeze-out.



Too close for comfort. The beads on the legs are too small to miter with a power saw. I cut them by hand and created the miters on the horizontal belt sander.



Off to a good start. Fitting the leg beads begins at the outside corner. This puts the easiest joint to fit in the most visible location.



Loose fit. The front to back rails of the drawer frame are slid into the grooves, but not attached until the frame is glued inside the desk assembly.

After testing the fit of the individual joints, I dry-fit the entire desk together and prepared for glue-up. First I glued up the legs to the side aprons. After leaving them clamped for a few hours, I glued and clamped up the side sections to the back apron and the front rails. Doing the glue up in stages is a lot easier than attempting the whole job at once. While it was clamped up, I checked the desk for square.

When the glue was dry, I installed the web frame parts into the desk. The web frame consists of a lateral and notched rear rail, three longitudinal rails (two side and one center), and the front rail of the desk. Both the front

and rear lateral rails are grooved to accept the longitudinal rails (front-to-back), which the drawers ride upon.

I inserted the tenons on the ends of the three longitudinal rails into the groove of the front rail without regard to their exact position. Then I set the rear lateral rail onto the other ends, and slid everything up into the desk. Before the glue set, I shifted and adjusted the longitudinal rails into perfect position and clamped everything up.

The small piece that divides the drawers is set between the upper and lower front rails and in front of the drawer partition. In order



Divide and conquer. The drawer-front divider is slid between the rails and attached with screws. The partition is placed on top of the rail and behind the divider.

to provide space for the drawer partition and (drawer) guides, I made this piece 3" wide, and cut the piece so the grain would run horizontally, minimizing the drawer fronts. Because the grain ran in the short direction, I cut a 1/4" dado into the back to accept the tongue on the end of the drawer partition. This step stabilized and strengthened the piece.

I applied glue to the drawer partition and set its tongue into the groove on the back of the face piece, then clamped it onto the center longitudinal rail and screwed it from underneath for extra strength. Later when the glue was dry, I glued the rear upper rail to the rear apron and screwed it to the edge of the drawer partition.

With the desk assembled, I measured and cut the beaded moulding that runs around the desk, just below the drawers. I rough cut the pieces with my gent's saw, then mitered and fit the pieces using my sanding jig. When all the pieces were fitted, I attached them to the desk with glue and a small pin nailer 1/8" above the bottom edge of the rails and aprons.

After the drawers were completed, I began to fit them. The fitting process was detailed in the February 2009 (#174) issue of *Popular Woodworking*. The drawer guides were rabbeted and cut 2" shy of the back apron, so they could easily be trimmed with a regular block plane. I intentionally made them oversized to intrude into the drawer opening and prevent the drawers from sliding home.

In order to fit the drawers, I carefully planed the guides, a few light strokes at a time, so the drawers could barely squeeze in. Next, I planed a little from each guide until I achieved an attractive and even spacing on both sides. Later I would plane a small rabbet on the bottom edge of the drawer front and plane the top edge of the drawer front to create an even gap all around the drawers' openings.

I thought that wood knobs, instead of metal, would create a warmer, friendlier feeling. So I mounted a small block between centers and turned it round. Then I secured one end into my three-jawed lathe chuck, leaving one end free so I could easily shape the dome of the knob.

After reducing the diameter to 5/8", I parted a shoulder about 3/4" from the end. Then I turned a slight dome on the free end and tapered the shank down to the shoulder. Using a narrow parting tool, I formed a 3/8"-diameter tenon, 1/2" long. The last step was to sand and finish the knobs while they were turning on the lathe.



Made to fit. I fit the drawer front first, then build the drawer to match the front. My process is detailed in the February 2009 issue (#174) of *Popular Woodworking*.



Planned to plane. The drawer runners are rabbeted underneath and cut short to allow me to reach in and plane them with my block plane.



Start to finish. The knobs are turned in a three-jaw chuck. The tenon is formed, and the knobs are sanded and finished before being removed from the lathe.

For the top, I carefully chose three mahogany boards with straight grain and an even warm color. After arranging my boards and cutting them to rough length, I cut the edges of each board to run parallel with the straight grain. My intention was to minimize the intrusion of visible seams and to create a harmonious surface. The glued-up top successfully created the impression of a single board and anyone viewing or inspecting it, strains to locate the seams.

After fairing the seams and hand scraping the surface, I cut the top to size, allowing a 1" overhang. To relieve the edge, lighten it and create some interest, I routed a 1/2" cove on the underside.

After centering the top, I drilled through the front rail and into the underside of the top. Along the front, the top was fixed, maintaining an even overhang all year long. At the back, I drilled elongated holes through the rear upper rail. These longer holes would allow the top to move, directing all the wood movement to the back of the desk.



Finishing touch. The beaded trim is attached 1/8" above the bottom edge of the lower rails and aprons.

After sanding the desk with #220-grit sandpaper, I sprayed on a coat of nitrocellulose sanding sealer. The next day, I rubbed the desk out with #0000 steel wool and sprayed on a two coats of satin lacquer. **PW**

Mario has been a woodworker, teacher and author for more than 30 years. He currently teaches at the Philadelphia Furniture Workshop. Detailed information about the school's classes is available online at philadelphiafurnitureworkshop.com.

PLUNGE-



These saws are the best for breaking down sheet goods, if that's one of your shop chores. But you'll need to dig into the features to make your purchase decision.

CUT SAWS

BY GLEN D. HUEY

Since DeWalt and Makita entered the United States plunge-cut saw market with Festool, the three have received immense interest and discussion. How are the saws different? Are the results of a crosscut or rip cut any cleaner than those made at a table saw? What features are common or unique on plunge-cut saws? I scrutinized a DeWalt DW5520, a Festool TS55 and a Makita SP6000 to see which, if any, of the saws stand out.

If you're looking for vast differences in the cuts produced by the various plunge-cut saws, I'm afraid you're going to be disappointed. I used each saw to cut plywood and hardwood, both with and across the grain, and for slicing samples of melamine. There is a small amount of tear-out (mostly across the grain as you might expect), but nothing significant. In fact, I compared those cuts with cuts made in the same materials at a table saw and again, the differences are minimal.

A Smooth Ride

A quick look at the guide rail or track designs is of interest. The Festool and Makita guide rails look very similar in profile—so much so, that they fasten together and align. The DeWalt track has a different profile. DeWalt's track is symmetrical and center-justified, which means you can operate the saw in both directions. With the others, you have to flip the rails to cut in a second direction. That could be an issue depending on the task.

Right on track. The commonality of these saws is a guide rail or track on which each slides—as well as the clean, straight cuts produced. Where differences show is in the unique features found when given a closer look.

But here's what is attention grabbing: All three plunge-cut saws ride and operate on a Festool guide rail. However, Festool's saw rides on a Makita track, but not on a DeWalt track. And a DeWalt saw doesn't work with a Makita track just as a Makita saw is not functional on a DeWalt track. Need a scorecard?

How Plunge-cut Saws Work

The Festool and Makita saws' plunge operation is like moving your wrist in a hammering motion. The DeWalt saw moves a bit differently. It rocks forward to make a plunge cut with an action similar to moving something from one spot to another—lift, move, then set back down. Switching between the two different motions causes one to think, but individually, their use is intuitive.

What makes these saws operate as they do is the blade set with a "toe-in" design. This allows the saw to cut at the front of the blade with the back of the blade held away from the freshly cut edge. Minimal burn and little tear-out on the money side of the cut is the result. This is also the major difference between the finished cuts from these saws and those of a circular saw when used in combination with a straightedge guide.

There are other features common to these saws, such as track adjusters to dial in the exact fit for a smooth slide, a lockable arbor for quick blade changes as well as blade depth-of-cut adjustments. And each saw is set up for dust extraction via an external vacuum. (See page 53 for more comparisons.)

A significant feature found on the DeWalt and Festool saws, but not on Makita's saw, is a riving knife. At first, you may question a riving knife's importance because the blade retracts into the saw if the tool is lifted from the track. But even with that action, there is still an opportunity for kickback and a riving knife defends against that action.

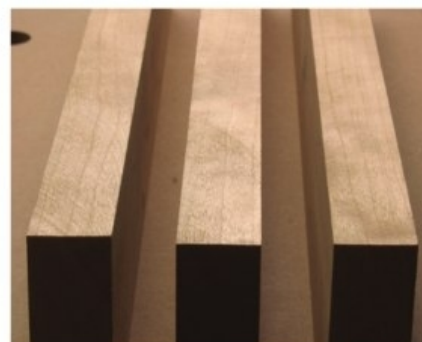

Not glue ready. The edges produced with plunge-cut saws are clean, but in the rake of the light, small saw marks can be seen.

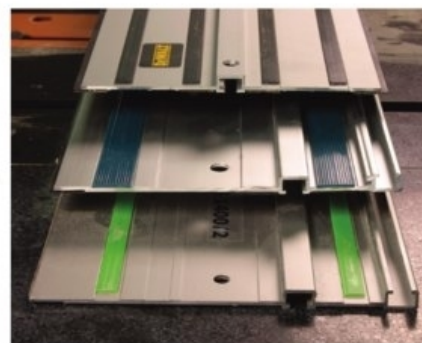

All aboard. Plunge-cut saws work best when slid along a guide rail or track. What saw works with which track is interesting.



Properly set. A plunge-cut saw is set up with the blade slightly canted at the front. Here you can see the paper-thin gap needed to make a saw work its best.



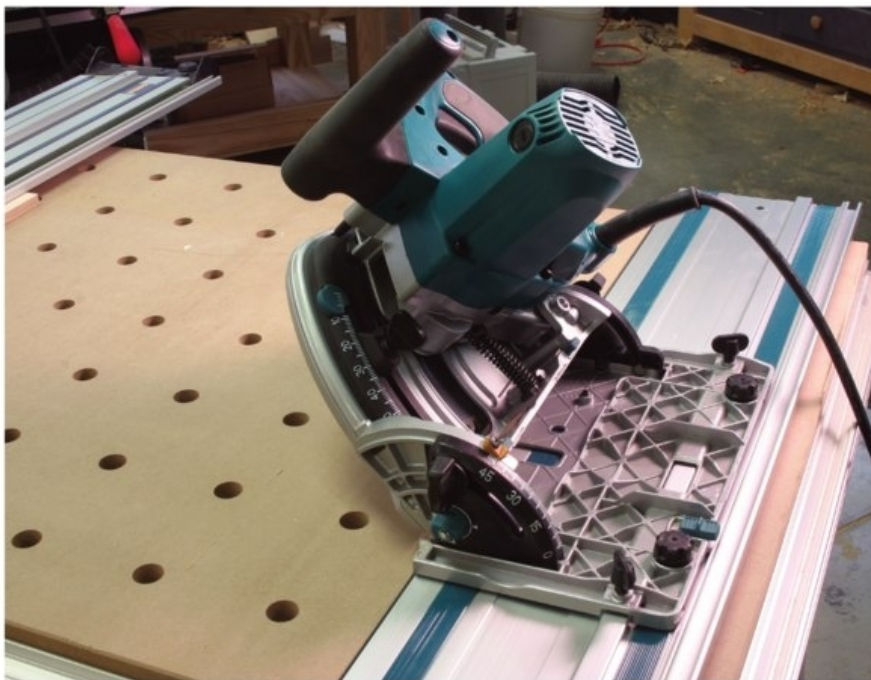

Stays on track. On the Makita, a small lever slides a catch into an undercut groove and does something that no other track saw can do – stay hooked to the track when all the weight is tilted.

Features – Makita SP6000

Makita's plunge-cut saw rivals DeWalt when talking power. At 9.1 pounds, the SP6000 is the lightest of the three saws. Its maximum depth of cut is 2³/₁₆" when set at 90° and 1⁹/₁₆" at 45°. This saw is the only tool that has positive stops at both 22½° and at 45°. The maximum angle setting (48°) is the highest of all three saws. The SP6000 is also the only saw that allows a -1° cut.

Another unique feature of the SP6000 is a slide lever that, when engaged, hooks into an undercut groove in a Makita guide rail to keep the saw from tumbling off the rail when set to cut an angle, but only on the Makita track.

Features – DeWalt DWS520

DeWalt's plunge-cut saw has maximum depth-of-cut potentials of 2¹/₈" at 90° and 1¹/₂" at 45° while on a track, and is the heaviest of the three plunge-cuts saws at 11.2 pounds. This saw's imperial markings for depth and angle adjustment are easy to read and account for the thickness of the track.

A unique feature found on the DeWalt saw is an anti-kickback catch. Release a knob and a small spring-loaded wheel, located in the center groove of the saw's base, is thrust against the track preventing backward movement. But this feature only works on the DeWalt track. (On a Festool guide rail, the DeWalt saw's center groove is not utilized.)

Features – Festool TS55

The TS55 has slightly less power than the other two saws and has maximum on-a-track cut of 1¹⁵/₁₆" at 90° and 1⁷/₁₆" at 45°. The Festool saw's depth-stop gauge is adjusted with a simple push, then move and release. However, the company continues to use metric measurements. The TS55 is the easiest of the saws for blade change – lift the FastFix lever (shown in the bottom right photo), plunge the saw until you here a click and you're set. The arbor locks as you turn the blade to loosen the bolt. Other saws require the use of a second hand to lock the shaft.

Also, the Festool saw is part of a woodworking system and there is an extensive number of accessories available for this tool.

A Total Toss-up

If breaking down sheet goods is a primary function in your shop, a setup with one of these saws is helpful. We found that all three tools made excellent cuts, their features were similar and the prices were in the same ballpark. We think a lot of purchasing decisions will be made based on brand loyalty (all three brands have intense loyalists). However, no matter which brand you choose, we don't think you'll be making a bad decision. **PW**

Glen is a senior editor of this magazine. Contact him at 531-513-2690 x11293 or glen.huey@fwmedia.com.

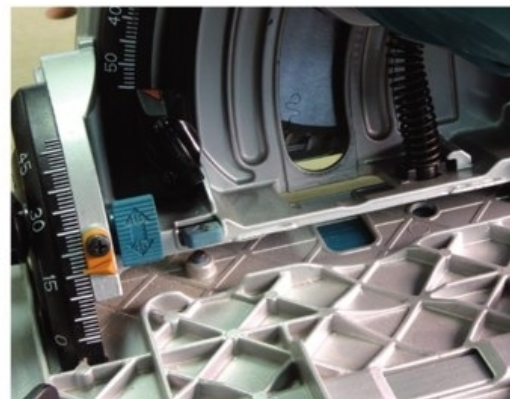

A tale of two levers. Flip a lever to bypass the 45° stop and cut at the maximum-cut angle of 48° – or push in the twin tabs to drop the saw to cut at a negative angle. These are two features that are unique to Makita's saw.

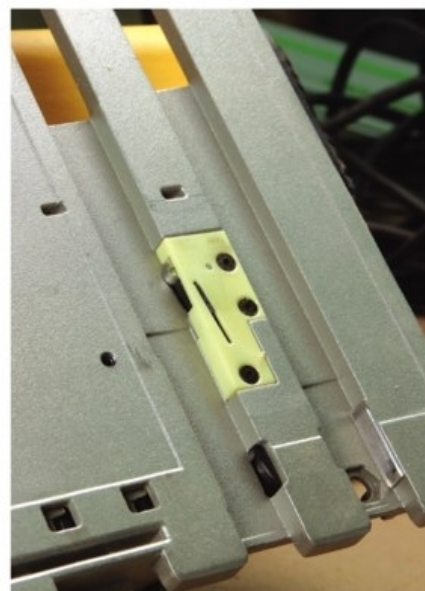

Spring to action. A spring-loaded roller locks the DeWalt saw to a DeWalt track. This is a great feature if you're using this saw as a panel-cutting tool.



Quick-change artist. Festool's saw is by far the easiest on which to swap out blades. It's a one-handed operation.

Plunge-cut Saws

MAKITA #SP6000

The 12-amp motor on Makita's plunge-cut saw spins the 6 $\frac{1}{2}$ "-diameter (165mm) blade between 2,000 and 5,200 revolutions per minute (rpm). This saw has a number of features I find useful. Being able to cut to a maximum 48° with a flip of a lever is nice, but to quickly find and set angled cuts at 22 $\frac{1}{2}$ ° and 45° with built-in positive stops is great – even if the 22 $\frac{1}{2}$ ° and 48° settings are factory set and not adjustable.

Additionally, this is the only saw that allows a -1° cut option. To reach that angle, you need to push in two stops at the saw's base, then lower the body of the tool. Once you're finished, a simple lift of the saw above the 0° line resets those stops.

On the downside, Makita chose not to include a riving knife on its plunge-cut saw, and the power cord is short – at 8' this cord doesn't cover the standard length of sheet goods.

An SP6000 will set you back around \$384, and don't forget to pick up a guide rail. Two guide rails are available: 54" (\$80) and 117" (\$200). The cost of a replacement blade is \$45.



MAKITA

Model #SP6000

makita.com

800-462-5482

DEWALT #DWS520

Spinning a 6 $\frac{1}{2}$ " 48-tooth blade to a variable speed between 1,750 rpm and 4,000 rpm is no problem for the 12-amp motor. In fact, there's plenty of power to make the maximum cuts of 2 $\frac{1}{8}$ " at 90° and 1 $\frac{1}{2}$ " at 45° while on a track. The saw can reach up to a 47° bevel cut and weighs in at 11.2 pounds, easily the heaviest of the three saws.

The DeWalt saw's built-in kickback catch is a unique feature, but there are two issues to consider. First, the feature is only usable when working on DeWalt's track. And second, while this catch works to thwart backward movement, it does nothing to keep the saw on the track. And once the saw is lifted from the track, the catch action is eliminated. But if you're looking to use this setup as a panel saw, the kickback catch is top shelf.

DeWalt's saw is priced at \$499 including a 59" track. Three track lengths are available: 46" (\$80), 59" (\$100) and 102" (\$230). Replacement blades are available at \$60.



DEWALT

Model #DWS520

dewalt.com

800-433-9258

FESTOOL #TS55

Festool has had its plunge-cut saw available in the States longer than either of the other saws. The TS55 saw has a 10-amp motor that produces sufficient power for variable blade speeds between 2,000 and 5,200 rpm. The saw includes a 48-tooth, carbide-tipped blade with an alternate-top-bevel (ATB) design that is 6 $\frac{1}{4}$ " in diameter or 160mm. This blade (as on the other saws) has a 20mm arbor hole. Street price for replacement blades is \$58.

At a weight of 9.92 pounds, I found this saw easy to maneuver along the guide rail and no trouble with day-long use.

The Festool cord is 13' in length, which makes it easy to stretch along the length of most sheet goods. And because this cord detaches at the tool, you'll be sure the power is off when making adjustments.

After a recent price increase, a TS55 is priced at \$500 including a 55" guide rail. Other Festool rails are available in eight different lengths, from 32" (\$63) to 197" (\$474).

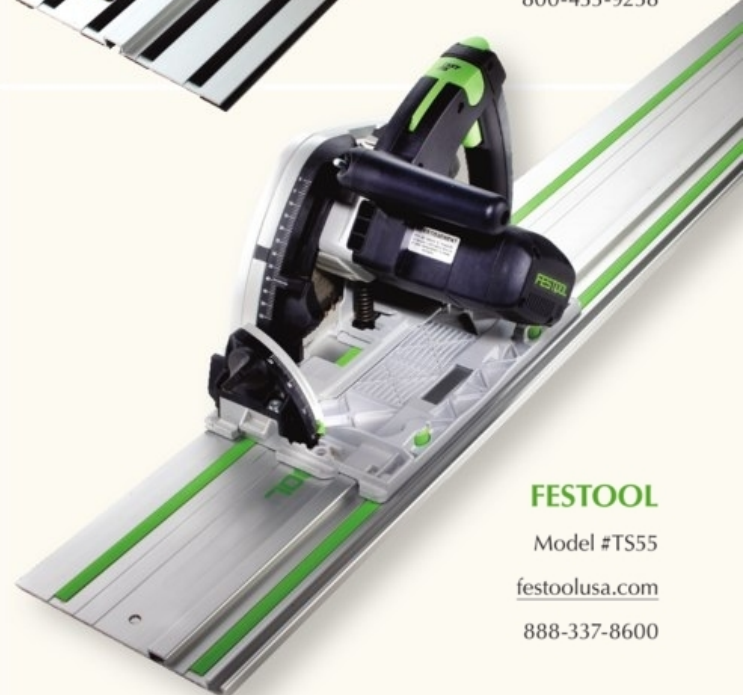

FESTOOL

Model #TS55

festoolusa.com

888-337-8600



Carving Spanish Feet

BY CHARLES BENDER

A Delaware Valley foot and a Pennsylvania ring-and-vase turning combine to develop a period-style design.

Years ago, when I first began my business as a period furniture maker, a close friend and mentor jumped on board to help kick off my backlog of work. He was a widely known collector of William & Mary furniture – his home was touted as the “mini-Winterthur” – and while he had no personal woodworking experience, he did know 17th- and 18th-century American furniture better than anyone I knew. He should have, considering he began his collection immediately following World War II. His initial project for me was to create a piece that is currently nonexistent in the antiques world. He wanted a Pennsylvania William & Mary wing chair.

With his passing earlier this year, I've reflected on that project with great fondness. We spent hours together researching period frames, turnings and foot variations. We felt strongly that wing chairs existed in Pennsylvania during this time period. These chairs were found in other regions of the Colonies; certainly they would have existed in Philadelphia. This city was the center of the Colonies for wealth, education and furniture making. Yet no chair of this type has ever been offered for sale on the antiques market.

With the help of some of the East Coast's leading collectors, antique dealers and museum curators, we came up with a design that represents what could have been made in Philadelphia in the late 17th century. We settled on a distinctly Delaware Valley version of a Spanish foot with concave flutes that form the "toes" that, while bolder and more dramatic than their New England counterparts, are fairly simple to carve. And we've adapted this design to use for a footstool.

Stock Preparation

Walnut was commonly used throughout the Colonies during the William & Mary period because it was plentiful and locally available. It looked and worked much like mahogany. Each blank starts out as a 2³/₄" square that is 14" long. That sounds a bit short for a footstool or an easy chair, but you have to remember there's upholstery on top of the completed base.

Next you need to create the pattern to which the legs will be sawn—they are cut at a band saw just as you would a cabriole leg. I use thin plywood for my pattern so I can repeat the layout any number of times. If you draw the design, it should be as though you are looking at the leg directly from the front. This results in a long rectangular section at the top with the profile of the foot at the bottom.

I begin by examining my leg blanks to determine which faces will be toward the outside of the stool (the show face) and which will receive the mortises for the rails. I try to match the quartersawn grain on two of the

surfaces that will be facing me as I look at the stool from the front or the back. When you start with those, you naturally match the flat-sawn grain on the ends of the stool.

Once you have determined your inside and outside faces, lay the pattern on an inside surface with the back of the pattern flush with the inside corner of the blank. Trace the design onto the blank. Then flip the pattern to the other inside surface and keep the back of the leg pattern flush with the same inside corner. When you look at the inside surfaces of the blank, you'll see your tracings with the leg back against the inside corner of the blank.



Best face forward. Once the foot blanks are sized and your pattern is drawn, transfer the profile onto two adjacent faces so the rear edges of the profiles meet at a corner.



Set, mark and turn. Offsets in the design cause the turning center of the foot bottom to be shifted away from the foot front. A marking gauge set off the top center is the best method to locate this point.

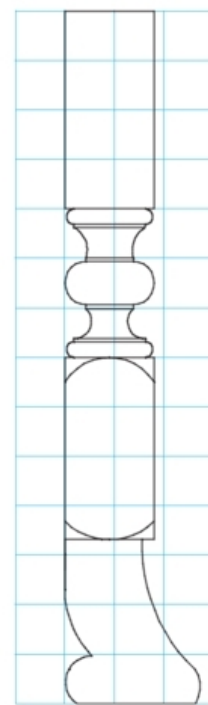

1 SQUARE = 1"
FOOT PATTERN



Transition details. The ring-and-ball design is very prominent in Pennsylvania furniture and adds a regional influence to the foot design.



Straighten up. A spokeshave is quick to level and flatten any rough surface areas left from the band saw.



Round that toe. The cross-grain cutting action with a gouge leaves a clean toe area, but just rough in this curve. There's more carving to do.



Layout begins. Mark out a flat area that's $\frac{1}{8}$ " from the edge of the profile, then continue the line along the back edge of the foot matching the curve of the foot.



Divide and conquer. Use a pair of dividers to lay out the first fluted area; mark a flat area $\frac{1}{8}$ " off the flute, then repeat. Extend the lines to the bottom of the foot, parallel to the outermost flat.



Time to carve. Use a #7 gouge to carve a shallow trough between the flat areas. Pay particular attention to those flat areas – try to keep a consistent width.



Three equals one. With one face completed (save for a bit of touch up), rotate the foot to flute the second face. Don't forget to carve the partial flute on the toe.

Turned Transition

At a band saw, cut to the lines, but leave a bit of material holding the waste in place to form a bridge. Cut the opposite face allowing the stock to fall free, then complete the cuts on the first side, pulling the design from the blank. Repeat these steps for each leg.

With the band saw work complete, locate and mark the center of each end of the stock. Find the center of the top of the leg by marking from corner to corner. Set a marking gauge off the inside surfaces to the center point, then work off the same inside surfaces using the marking gauge to scribe the "center" onto the bottom of the foot. The bottom center will not be centered on the foot, but it will be the same center as that of the square stock.

After extensive research, it was decided to apply a Pennsylvania ring-and-ball turning as

the transition area between the foot and the balance of the leg. Chuck the piece in the lathe and turn the transition following the provided profile. Make sure to ease the top edge of the square portion of the block at the base of the ring-and-ball turned area.

Clamp the blank in your vise, then flatten the sawn surfaces of the square stock with a chisel or spokeshave.

Carving the Details

The front toe is pretty heavily rounded off. A spokeshave or an inverted carving gouge works well for this. I use a #3 or #5 straight gouge that's 25mm in width.

As with any carving, the better the layout, the better the end result. Start by marking off the first flat at $\frac{1}{8}$ " from the back edge of the leg just where the foot meets the square stock. Use your finger as a guide to extend that line down to the scroll of the foot. As you can see in the photo at the top, the line curves back slightly at the scroll. A little freehand sketching brings the line down to the bottom.

With a divider set at approximately one-third the width of the foot measured just below the square stock, mark the edge of the first concave flute. Extend that line just as you did on the initial line. Lay out and mark a second $\frac{1}{8}$ " flat area, extending that line to the bottom of the foot as well. Use the dividers one last time to mark the area for a second flute. Before putting down your pencil, sketch a curve on the lower end of the block just above the foot that matches where the square stock meets the top edge of the turning.

Grab a #7 gouge about the size of the flutes you've drawn, I use either a 12mm or 14mm gouge depending on which best fits the layout, and begin to carve a shallow trough from the peak of the scroll up to the square stock. Carve from the opposite direction to finish the flute from the scroll to the bottom of the foot.

As I carve the flutes, I try to adjust any drawing errors made in the layout. The trick is to pay attention to the width of the flats between the flutes. As you carve, you may find it necessary to adjust your course to keep the flats a uniform size. Three more full-length flutes and you've got a Spanish-style foot.

At the curved line where the square block transitions into the foot, use a 2"-wide bench chisel to pare away waste until the curve is smooth. A little sanding, a few mortises and you're ready to build a wing chair, a footstool or any project on which you'd like to use Spanish feet. These feet can add a bold flair to many different projects and they're fun and easy to make. You may even do a little research of your own and try other regional variations. **PW**

Charles is a nationally renowned period furniture maker near Philadelphia, Pa., and is the lead instructor of The Acanthus Workshop. To learn more about his furniture and the school, or to contact him, visit acanthus.com.

Twister

This undulating band saw box is simple to make, and it makes a great gift.



BY DAVID THIEL, JIM STACK
& LOIS KEENER VENTURA

Yes, you could say building this box is like dancing. Your partner is that beautiful wood you've just found or have been secretly saving for the past decade, and the music is the sound your tools make.

This band-sawn box design is an intermediate project due to the number of drawers and amount and type of carving involved. The carving and shaping can be done quickly with coarse-through-fine sandpaper on a belt sander, oscillating spindle sander and with sanding drums on a portable drill, then refined with a finishing sander and hand sanding. Some of the carving – mainly at the saw kerfs – must be done with straight chisels and lots of coarse-through-fine sandpaper wrapped around dowels, flexible rubber sanding accessories if you have them, and, of course fingers. (You definitely need these, so take special care around a running band saw blade!)

When selecting wood, look for grain patterns that are exceptional. Burls, curls, spalt-ing, unusual colors and yes, even cracks, splits, worm or bug holes and checks can be used to create a box that will truly be one of a kind.

When you cut a board into shorter lengths, inspect the end grain and match them to each other when gluing up a blank for your box, such as bookmatching. This can make your box sing a tune that no one has ever heard.

—LKV

Make the Carcase from a Block

The photos on the following pages will take you step by step through the building process, but an overview here will be helpful.

First select your wood, choosing a nice-looking grain pattern. You'll probably need to glue up a sandwich to achieve your desired thickness (which can vary according to your likes). Wooden handscrews are the best clamp choice for this step, applying even pressure at all points on the glue-up.

Flatten the bottom squarely to the back of your box blank. A jointer is the easiest tool to use for this, but a handplane, disc sander or stationary belt sander will also work.

Twister. The organic curves and custom pulls in this eye-catching design can be made from any combination of woods.

Now cut a 1/4"-thick piece off the back of the blank. (This piece, which will be glued back on after you're done cutting the drawers out, will be the box's back.)

Make a copy of the pattern at right and attach it to the front of the box blank using spray adhesive. Follow the solid lines to cut out and remove the drawer blanks from the center of the box. Perform any finish sanding on the interior of the box at this time.

Next, glue the back you removed earlier back on the box. After the glue is dry, cut out the outside box shape and sand the exterior smooth.

Drawer Cavities

To form the drawers, a 1/2"-thick front and 1/4"-thick back are sliced from each blank. Then draw the cavity outline (the dotted line on the pattern) on the front of the remaining drawer blank.

To give the drawer cavity square corners, make the two side-cavity defining cuts first. Then start at one top corner of the cavity and cut diagonally toward the bottom of the cavity, cutting along the bottom toward the opposite corner. Cut back along the bottom line to finish creating the drawer cavity. Then glue the drawer backs and fronts back on the drawers.

Basic Tools List

- table saw
- 14" band saw
- 3/16" band saw blades
- wood glue
- a variety of clamps
- stationary belt sander
- portable drill and 1" x 2" sanding drum
- finishing sander
- sheet sandpaper in #80, #120, #180 and #220 grits
- coarse-, medium- and fine-grit sleeves for drums and belts

OPTIONAL TOOLS

- 1/4" band saw blade
- oscillating spindle sander
- plunge router
- router table
- flocking kit

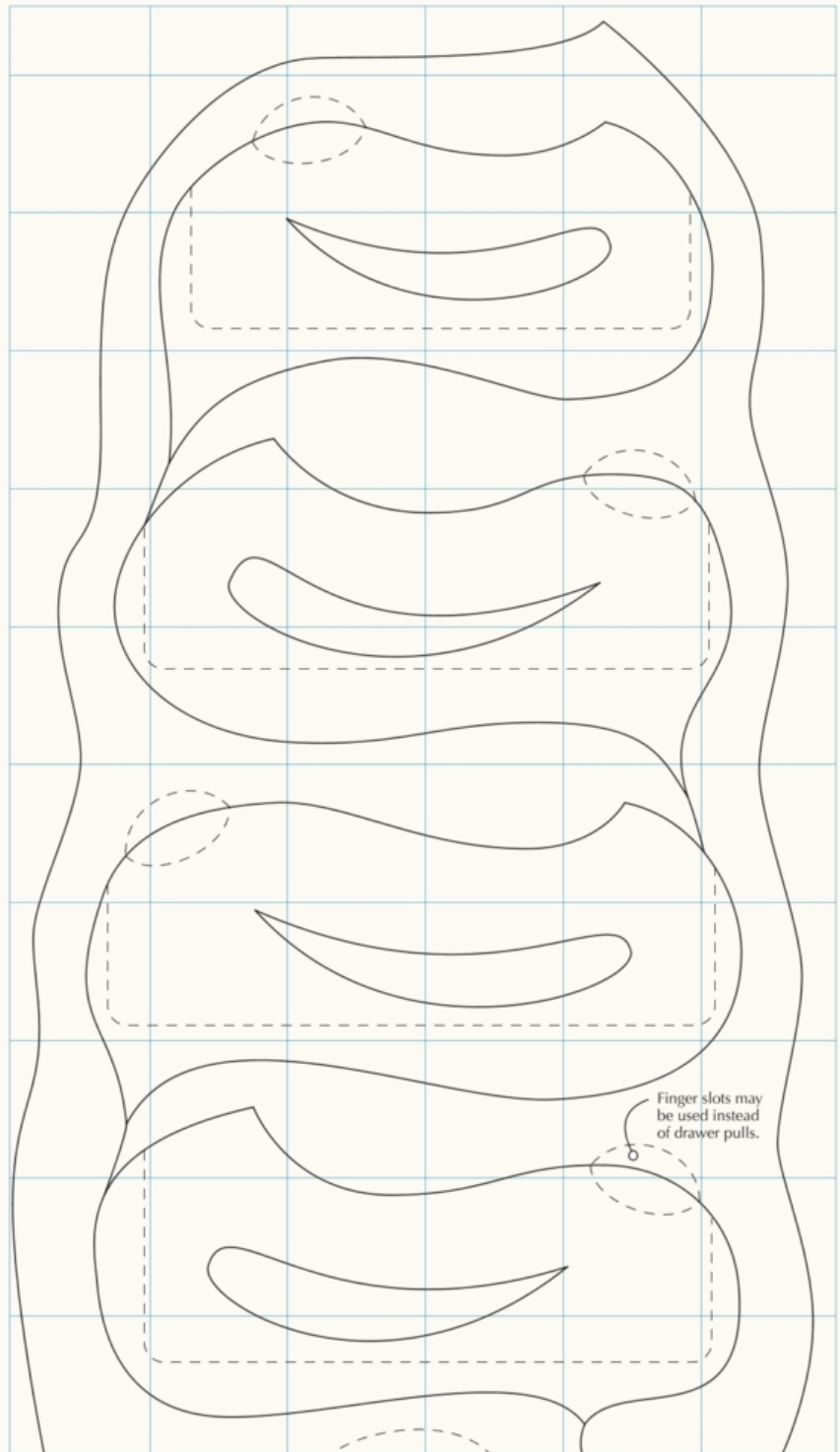

TWISTER PATTERN

1 SQUARE = 1"

Excerpted from "Sculpted Band Saw Boxes" © 2008 by Lois Keener Ventura. Used with permission of Popular Woodworking Books, an imprint of F+W Media, Inc. Visit your local bookseller or call 800-448-0915 to obtain a copy.

Shaping

Shaping the edges of the box and drawer edges can be done several different ways. The safest way (in terms of not removing too much material at a time) is to use a wood rasp. I prefer a fine-cut rasp. A coarse rasp can tear out chunks of wood at the sharp corners and delicate edges of the box.

An oscillating spindle sander can be used to rough out areas where a fair amount of material needs to be removed. Final shaping can then be done with files and sandpaper.

A router mounted in a table or handheld (a

trim router is just the right size) can be used to round over the edges of the boxes. A router is fast and unforgiving, so run test pieces to double-check your setup.

Custom Pulls Finish the Box

Drawer pulls can add a dramatic effect to your boxes. Cutting them can be done safely on the band saw. There is no kickback – the work is held tightly to the table by the downward sweep of the blade.

Shaping drawer pulls can be done using the same tools used to sand the boxes. Again,

a power sander removes material quickly, so unless you're a safecracker, you will want to keep your fingerprints.

Hand sanding is the final step.

After your pulls are cut out, shaped and sanded, and, when the box is ready, you can attach them to the drawer fronts. A little dab of glue will do.

The box featured here is mahogany with ebony pulls, and is finished with three sprayed coats of semi-gloss lacquer – but you can customize yours however you like.

—JS

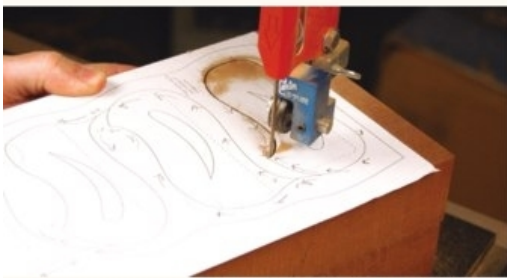

1 In and out. This box is a great-looking design, but it does require you to back the blade out of the pattern a number of times. This is caused by the peaks on the drawers. If there's a sharp peak, you can't turn sharply enough to create the point. The look is worth the effort, but be aware. The first cut starts at the bottom of the box and undulates up to the peak of the lower drawer.



2 The other side. When I'd completed the cut in step one, there was enough inner tension in the wood to close the opening gap, making it very difficult to back the blade out. I eventually tapped a wooden wedge into the gap to make enough room to back the blade out.

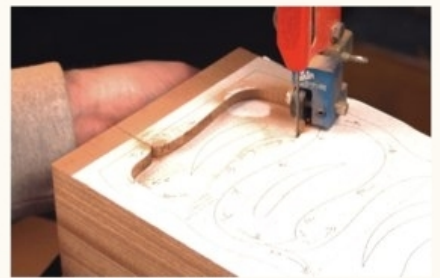

3 Free. When the second cut is complete, the drawer will be free of the box. Stop the saw and lift the box slightly to make sure the drawer is loose.

4 Pop and drop. With the machine off, raise the guide bar and lift the box above the drawer.



5 One down. There's no need to back the blade out this time, just let the box settle back onto the band saw table. The drawer is free and you're set up to make the next cut.

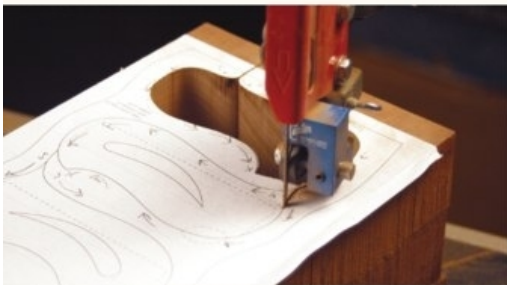

6 Round two. Start into the second drawer from the rounded left edge of the first box. Make this as smooth a transition as you can. It will pay off in the look of the piece.

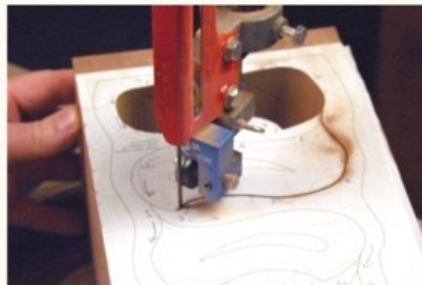

7 Point to the left. The rest of the box is a series of turns along one side of the box, ending in the top point.



8 Point to the right. Then you back out of that cut, re-enter the cut and swing around to the other side to finish at the point again.



9 Smooth curves. With the drawers separated from the box, it's time to move to the spindle sander. These openings are a nice size to accommodate a spindle drum of a larger diameter, making it an easier sanding operation.



10 Good clamps. Wooden hand screws are often seen as archaic and interesting, but not often used. Part of the problem, I believe, is that they take some getting used to for the perfect adjustment. It's worth the effort. These clamps are perfect for working with band-sawn boxes. The wide, long and flat faces allow even pressure across a number of awkward locations. As seen here, the clamps easily reach across each of the drawer dividers to make sure the box is strong and the seams are tight.



11 Front ... While the glue on the box dries, head back to the band saw to work on the drawers. Set the fence for a $\frac{1}{2}$ " spacing and cut each of the fronts from the drawers.

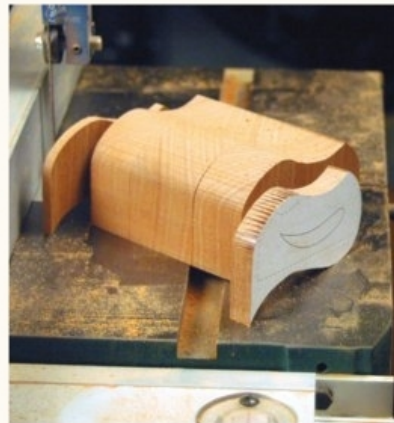

12 ... and back. Reset the fence for $\frac{1}{4}$ " and repeat the process to remove the backs of all four drawers. Check twice before you make the cut to ensure you're actually cutting off the back and not the front. Easy mistake.



13 Other clamps. The other perfect clamp for band-sawn boxes is a one-handed, fast-adjust clamp. It only takes a little pressure to hold the drawers together, but the real benefit is in their one-handed operation. You need the other hand to adjust the pieces so they're aligned properly. Otherwise you add a lot of sanding and end up with a misshapen drawer. The wide, soft pads on the clamps are pretty useful, too.



14 Handles. I opted for a different handle than Lois had drawn, feeling that the grain of the mahogany was so attractive that I didn't want to hide it with a larger handle. I was looking around the shop and found a leftover strip of ebony and decided that would do nicely. I first cut the handles to size ($\frac{3}{8}$ " \times $\frac{3}{8}$ " \times $\frac{3}{4}$ ").



15 Trapezoid. A rectangle didn't work for the look, so I decided on a trapezoid shape for the handles. This also makes them better handles, so two good reasons to get the fingers close to the sanding disc.



16 Pull! For the longer side of the handles, I moved to the belt sander. Do be cautious here, because it doesn't take much to launch the handle across the room. It makes sense to make an extra handle or two, just in case. **PW**

—DT

Grinder Tool Rest Jig

BY BRUCE D. WEDLOCK

This simple jig makes it easy to set your rest to specific, repeatable angles.

Tool rest setting. Hold the jig firmly to the wheel and the tool rest, then tighten. The grinder will now grind the tool to the desired bevel angle.

The many articles on sharpening chisels and plane irons always include some discussion of the desirable bevel angle of the blade. For chisels, it ranges from 20° for paring chisels to 25° for bench chisels to 30° or even 35° for mortise chisels. But how does one accurately set the grinder's tool rest to achieve the desired angle? And how might the curvature of the hollow grind come into play?

Years of trial and error finally prompted my development of a simple jig to quickly set the grinder's tool rest to a specific bevel angle in an accurate and repeatable manner. The

detailed analysis involves substantial geometry and trigonometry. (If you're interested in this information, send an e-mail to wedlock@alum.mit.edu.)

Jig Construction

The bevel angle for a hollow grind is defined in the drawing at right. This is the angle at which the honing stone is normally applied to the hollow-ground blade.

The tool rest jig is shown in operation in the opening photograph. The curved portion is firmly held against the grinding wheel and

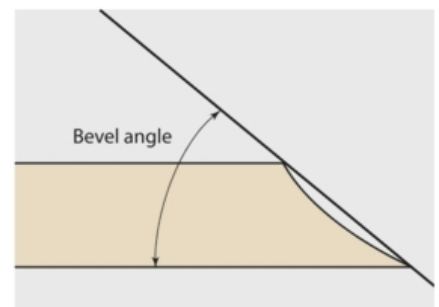

Bevel angle. The bevel angle is measured from the base of the blade to the line defined by the top and bottom edges of the hollow grind.

the flat portion is held against the tool rest while it is tightened. This sets the tool rest relative to the wheel to produce the desired hollow-ground bevel angle.

To begin construction you need the diameter of your grinding wheel. If your wheel is new, you can assume it's the diameter on the packaging; if it's been substantially used, you should remove it and measure its actual diameter. The jig's angular accuracy depends on having a correct fit to the wheel's diameter.

Next, obtain a piece of $\frac{1}{2}$ " MDF with the dimensions shown in the drawing at right. Draw a line one inch below the top edge. From the midpoint of this line, use a protractor to draw a second line at the desired bevel angle plus 90° as shown.

With a compass set to the wheel's radius, place the compass at the midpoint of the 1" line and strike an arc on your second line. Now place the compass at the intersection of the arc and second line and draw an arc intersecting the original line as shown in the layout illustration at right. This completes the layout.

Carefully rip the jig along the 1" line, leaving the line just visible. Band saw the arc close to the layout, leaving some material, then carefully sand to the arc. Test the arc on your grinding wheel to check for a snug fit as you sand it. You may need to trim the length of the jig to fit your grinder's wheel guard. You can make small adjustments to the arc's fit by holding it against the grinding wheel and turning the wheel by hand. Finally, mark the bevel angle on the jig. You are now ready to set your tool rest as shown in the opening photograph.

Honing

Once the blade's bevel is hollow ground, you will need to go through the honing grits to finish the edge. While practice will make you adept at freehand honing, many find an inexpensive honing guide will do a better job. There are many honing guides available, and some come with angle-setting jigs. But what you really want is your honing guide set for the bevel angle ground on your blade. A setting jig may not match this exactly. There are several factors such as blade thickness and taper angle of a chisel that introduce small variations into the exact bevel angle set by the tool rest jig, so the best approach is to set your honing guide to match the bevel angle that your jig produces. This is easily accomplished as shown in the photo at right.

Use a straightedge applied to the edges of

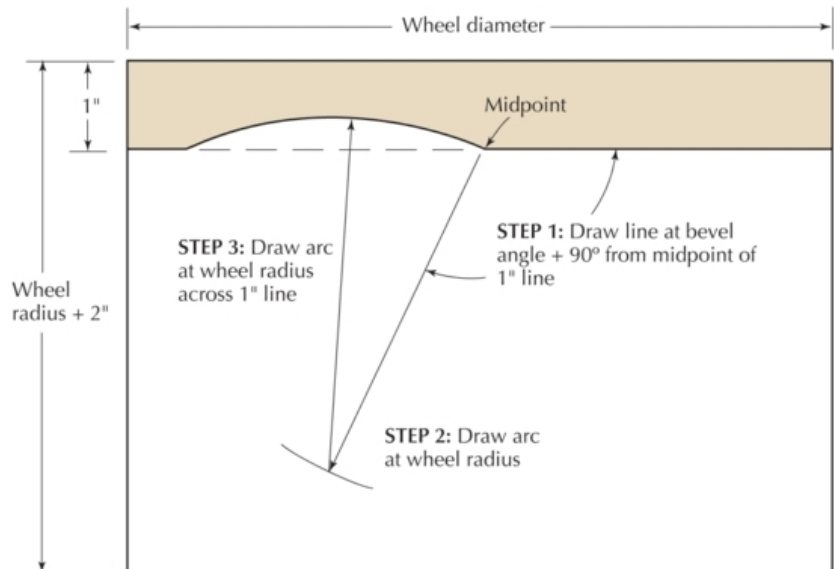

Jig layout. This shows the geometrical layout to produce a specific bevel angle. The shaded portion is the final jig.

the hollow grind and adjust the guide's roller to match that angle. Once this is done, record the blade position in the guide by butting the guide against the edge of a piece of plastic laminate and scribing the blade edge location with a sharp knife. This distance won't change as the grinding jig always produces the same bevel angle. You now only need to place a ground blade edge on the scribe line to set the honing guide position.

Conclusions

A jig to accurately set the tool rest on your grinder will eliminate the guesswork of repeatedly tweaking the bevel angle. There are several factors that come into play when calculating a bevel angle, such as blade thickness and taper. For typical chisels, these combine to an error of less than one degree, so they were neglected in setting the bevel angle for

the jig. For a plane blade that has no taper, you should add one degree to your desired bevel angle when laying out the jig to compensate for these factors.

It should go without saying, but to get top results, you need to use a soft grinding wheel such as an #80-grit aluminum oxide white or blue wheel on your grinder. Then true it square and flat with a diamond wheel dresser. Dressing removes glazed surfaces, making the wheel cut faster and cooler. In like manner, be sure your honing stones are flat. Waterstones sharpen fast, but they also wear fast. To get the best results, true them with an appropriate flattening stone. These steps will save you time in the long run and give you razor edges. **PW**

Bruce retired as an electrical engineering teacher from MIT in 2000; he now enjoys more time in his shop.



Adjust honing guide. The wheel and both edges of the hollow grind should all touch a straightedge to hone the desired angle.

Finishing the 5 Types of Woods

Organize all the woods into categories to determine the best finishing strategy.

Woodworkers choose among dozens of wood species for projects. Unless you've actually used many different woods and experienced how they machine, feel, smell and respond to stains and finishes, you probably find making an intelligent choice confusing. There needs to be some way to organize the woods so decisions are easier.

And there is.

To begin with, you can divide all woods into five large categories: pine and related softwoods; coarse-grained hardwoods; medium-grained hardwoods; fine-grained hardwoods; and exotics.

Traditional furniture is rarely made of pine or exotics, so for simplicity's sake, let's reduce the categories to three: coarse-, medium- and fine-grained hardwoods. And to begin with, let's deal with just the five most common traditional furniture hardwoods: oak, walnut, mahogany, cherry and maple.

Importance of Grain

Grain is the most important indicator for identifying woods. Grain is the open pores or pitting in wood that give it texture. In finished wood you may have to look closely to see the grain because it may have been filled.

Most old furniture was made with one of these five woods, so identifying woods in antiques is fairly easy. If the grain is coarse, the wood is likely oak. If it is fine – that is, if there's no obvious pitting – the wood is probably cherry or maple. If there is pitting and it's finer and more evenly spaced than in oak, the wood is almost always walnut or mahogany.



A fan of woods. Pictured are a number of woods woodworkers choose among for projects. Clockwise from the top are pine, oak, walnut, cherry, butternut, mahogany, ash, gum, soft maple, poplar, chestnut, teak, rosewood and ebony.

To tell the difference between cherry and maple and between walnut and mahogany, the color of the heartwood is key. On an antique you may need to cut a sliver from an inconspicuous place to see its color. On newly milled wood, you can simply look at the color.

If the color of fine-grained wood has a reddish tint, the wood is cherry. If near white, it's maple. If the color of a medium-grained wood is charcoal gray, it's walnut. If reddish, the wood is mahogany.

Keep in mind that oak can have a coarse

grain when plainsawn, or less coarse when quartersawn. Quartersawn oak is usually easy to identify because of its medullary rays.

Additional Woods

Of course, wood identification becomes more difficult when more woods are added. Traditionally, chestnut, elm and ash were sometimes used instead of oak. Each is coarse grained but subtly different. You just have to learn to recognize these differences.

Butternut, hickory and pecan were also used, and their grain resembles walnut and mahogany. Color can help in identification. Butternut is tan; hickory and pecan are tan with a slight pink cast.

There are lots of fine-grained woods in addition to cherry and maple, including birch, poplar, gum, beech, yew and holly. Gum and beech have a color similar to hickory and pecan. Yew is light brown to reddish. The heartwood of poplar has a distinct greenish color, which ages to light brown. The others, and the sapwood of poplar, are near white.

To distinguish between these fine-grained woods, you need to recognize subtle differences in figure. Figure is primarily grain orientation, the appearance of which has a lot to do with the way boards and veneer are cut, but also small distinguishing characteristics such as the flecks in cherry, maple and beech.

Exotic Woods

Mahogany could be classified as an exotic wood because it grows in jungle areas. But



Coarse-grained woods. Common coarse-grained woods include from the top: plainsawn oak, quartersawn oak and ash. All stains and finishes look good on these woods.

mahogany has been used so extensively for so long, it makes more sense to classify it as a medium-grained wood along with walnut, hickory and pecan.

With the exception of teak and rosewood, exotic woods were rarely used until recently, and then usually just for decoration and veneer. Now a wide variety of exotic woods are used for bowl turning, decks and furniture.

Most of these woods are medium-grained, but many are very distinctive in color and figure and therefore fairly easy to identify once you have become familiar with them. I don't have any easy categories that will help.

Finishing the Five Categories

Here are some thoughts about finishing each of the five categories of wood.

Pine and related softwoods have a very pronounced grain—soft, absorbent, white spring growth alternating with hard, dense, orange summer growth. The spring growth absorbs stain well, but the summer growth doesn't. So staining these woods usually reverses the color, making the spring growth darker than the summer growth.

Pine also tends to blotch, which can be quite unattractive.

On the other hand, pine finishes well with any finish, though I don't like oil finishes because so many coats are usually required

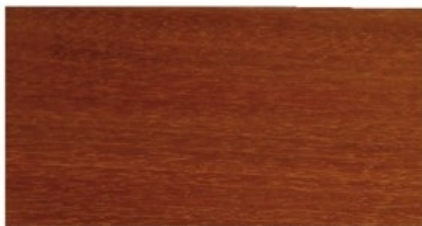

Medium-grained woods. Three common examples of medium-grained woods used in wood-working are from the top: mahogany, walnut and butternut. These woods are widely considered the most elegant when their pores are filled. All stains and finishes can be used successfully.

to bring the sheen of the spring growth even with that of the summer growth.

Like pine, fine-grained woods tend to blotch—often in an unattractive way. But sometimes, as with curly, bird's-eye and mottled woods, the blotching is attractive. As I have described often in these pages, you can reduce the blotching by applying a washcoat (thinned finish) before applying the stain, but the coloring will then be lighter.

All fine-grained woods finish well with any finish, but oil finishes require many coats for a nice appearance. Water-based finishes look wonderful on the white woods because they don't add any yellow/orange coloring, but they make cherry look washed out unless a stain is applied under the finish.

Medium-grained woods finish to look the most elegant of all woods as long as the pores are filled. This is one reason mahogany and walnut have long been considered the premier furniture woods.

All finishes except water-based look wonderful on these woods, and water-based also looks fairly good if a stain is applied under the finish.

All stains and finishes also look good on

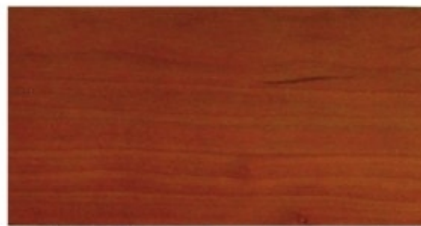

Fine-grained woods. Woodworkers use a great many fine-grained woods. Examples include from the top: cherry, curly maple and beech. As with most fine-grained woods, these tend to blotch, especially when stained. But the blotching is often considered attractive as with curly maple. Water-based finishes look especially good on the white woods but make darker woods such as cherry look washed out unless a stain is used.

coarse-grained woods. Only quartersawn oak looks good filled. Plainsawn, coarse-grained woods look plastic, in my opinion, when filled. The filled areas are too wide.

Water-soluble dye stains don't color the pores well in coarse-grained woods. If you use a water dye, follow it with an oil-based wiping stain of a similar color, either directly over the dye or over a washcoat, to add color to the pores.

All stains and finishes (water-based with a stain applied underneath) also look good on exotic woods. The common finishing problem with these woods is getting an oil or varnish finish (not others) to dry in a reasonable time because of the natural oily resins many of these woods contain.

To overcome the problem, wipe the surface with naphtha or acetone just before applying the first coat of oil or varnish. Then apply the finish right after the solvent evaporates off the surface. **PW**

Bob Flexner is author of "Understanding Wood Finishing" and a contributing editor to Popular Woodworking.

BY DOUG FULKERSON

The Allure of the New

If all you have is a hammer, well, you might need another hammer.

One of my favorite quotes is Baruch's Observation: If all you have is a hammer, everything looks like a nail. It seems like an accurate observation of the way people adapt to their surroundings. When it comes time to move out of your apartment your Honda Civic suddenly looks like a Ford F150. Just drive by a good-sized college or university at the end of the spring semester and you'll see this in action.

But sometimes the reverse is true. Maybe all you have is a hammer, but it isn't the right hammer. Sure you can drive an 8d nail with a 9-pound sledgehammer, but you wouldn't use it to drive a finishing nail into the moulding of a jewelry box. It would mar the finish, slightly.

Both extremes are easy traps to fall into while woodworking. At what point do you have the "right" tools to finish a project? Tool catalogs arrive in your mailbox with their glossy photos and tantalizing descriptions of the latest gadgets to make all your projects look like they were made by a test-tube baby fertilized with Duncan Phyfe, Sam Maloof and Frank Klausz's DNA.

How could a hopeless wannabe woodworker like you hope to make a dovetailed box without the "Tail Master 5000?" The photos of the sample cuts made with the TM5000 make you yearn for it like a miser yearns for gold. It gets to the point that you just know the only thing stopping you from becoming a brilliant furniture maker is not owning the TM5000. You can't eat. You can't sleep. Your trusty and

quite serviceable dovetail saw gathers dust as you wonder if selling one of your kidneys on the black market would be enough to purchase the TM5000 and its "Houndstooth Dovetail Adapter Kit."

If you survive the siren song of the tool catalogs, the "whatchyaneed" guys are there to further hobble your self-esteem. A "whatchyaneed" guy is that friend, neighbor or relative who believes they know what you need better than you do.

After a quick glance at your shop they quickly say to you, "Whatchyaneed is a JointMaster 9000. That JointMaster 4500 won't do as good a job." Having seen his JM9000 turn

a 22" tree trunk into an 18" x 18" beam in four passes, you realize the inadequacies of the JM4500. The largest board you've ever needed jointed so far during your woodworking career was a 4 x 4, but you never know when you will need to add a timber-frame addition to the garage. Better safe than sorry, you tell yourself, and wonder what other body parts you could sell.

The truth of the matter is, we often have enough tools to handle a project if we get a little creative. That tenon a little thick and you don't have a shoulder plane? Try a bench chisel. Don't have a dedicated mortiser or a drill press? You might be surprised how well a cordless

drill and a chisel can make a mortise. Have a new plow plane on back order and need a groove cut into a drawer? Start it with a chisel and make multiple passes with a router plane.

Don't let your lack of gizmos keep you from trying a project. Use the tools you have. So much of woodworking is about solving problems. Let your creativity flow into how you make things as well as what you make, and you'll become a better woodworker.

By the way: Anybody interested in a used, but well-maintained uvula? See, my buddy brought a tool catalog to my garage yesterday **PW**

Doug is an amateur woodworker by night, and by day a manager for a trucking company. He lives in Shepherdsville, Ky.

