

21-143

REALISTIC[®]

Service Manual

TRC-30A

CB 5-WATT 23-CHANNEL BASE/MOBILE TRANSCEIVER

Catalog Number 21-143



CUSTOM MANUFACTURED FOR RADIO SHACK  A TANDY CORPORATION COMPANY

CONTENTS

	Page
SPECIFICATIONS	2
BLOCK DIAGRAM	3
DISASSEMBLY	3
ALIGNMENT OF RECEIVER SECTION	4
ALIGNMENT OF TRANSMITTER SECTION	5
TEST EQUIPMENT SETUP DIAGRAM	6
ANTENNA SYSTEM	7
ALIGNMENT POINT (CHASSIS LAYOUT)	8
TRANSISTOR VOLTAGE CHART	9
CRYSTAL SYNTHESIS TABLE	9
SCHEMATIC DIAGRAM	10 & 11
CIRCUIT BOARD DIAGRAM (BOTTOM VIEW)	12 & 13
CIRCUIT BOARD DIAGRAM (TOP VIEW)	14
TRANSISTOR LEAD IDENTIFICATION	14
TROUBLE SHOOTING	15
REPLACEMENT PARTS LIST	16–22

SPECIFICATIONS

	Nominal	Limit
RECEIVER		
SENSITIVITY		
10 dB (S + N)/N	0.5 μ V	1.0 μ V
20 dB (S + N)/N	1.5 μ V	2.0 μ V
SELECTIVITY		
at \pm 10 kHz	60 dB	50 dB
at -6 dB	6 kHz	3.5–8 kHz
SPURIOUS SIGNAL REJECTION	-55 dB	-50 dB
SQUELCH RANGE		
minimum	0.25 μ V	0.5 μ V
maximum	1000 μ V	100–10000 μ V
IF FREQUENCY	11.275 MHz	
	455 kHz	
AUDIO POWER OUTPUT (in PA use, 10% distortion)	4.0 W	3.5 W
AUDIO FREQUENCY RESPONSE (compared to 1 kHz)	400 Hz: -6 dB	400 Hz: -6 \pm 5 dB
	2 kHz: -8 dB	2 kHz: -8 \pm 5 dB
IMAGE RESPONSE	28 MHz: 46 dB	28 MHz: 40 dB
	other: 51 dB	other: 45 dB
TRANSMITTER		
DC INPUT POWER	12.0 V x 390 mA	
RF OUTPUT POWER	4.0 W (AC > 3.3 W)	3.5 W (AC 3 W)
SPURIOUS RADIATION	55 dB	50 dB
MODULATION	+100 -90%	\pm 85%
RF FREQUENCY STABILITY	\pm 0.002%	\pm 0.005%
GENERAL POWER REQUIREMENT	12–14 V DC Positive or Negative Ground	
MAX. POWER CONSUMPTION	25 watts	
MICROPHONE	Dynamic	

NOTE: Nominal Specs represent the design specs; all units should be able to approximate these—some will exceed and some may drop slightly below these specs. Limit Specs represent the absolute worst condition which still might be considered acceptable; in no case should a unit perform to less than within any Limit Spec.

BLOCK DIAGRAM

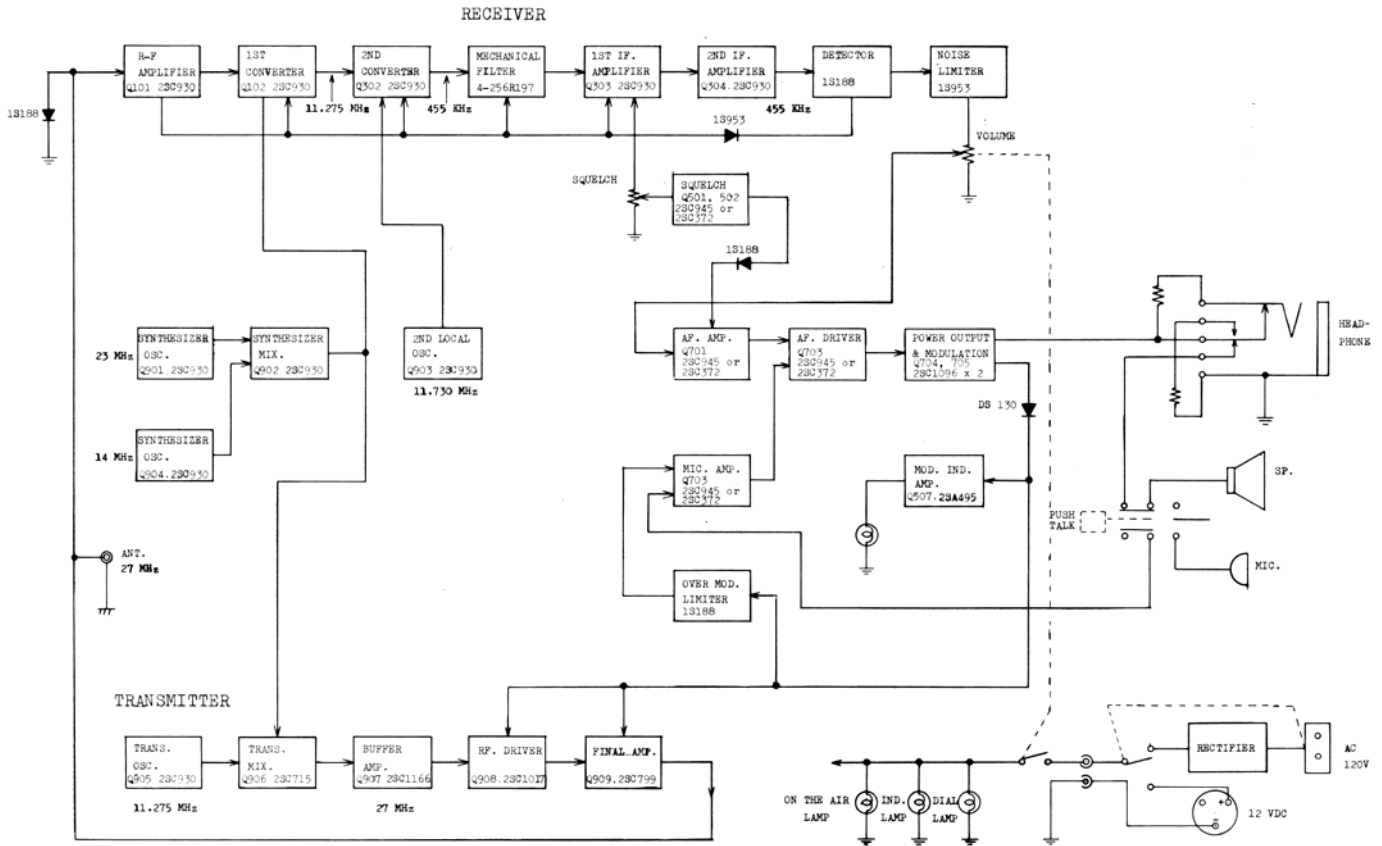

Figure 1

DISASSEMBLY

1. Removal of case:

After removing mounting brackets, remove the four screws holding case as shown in Figure 2.

2. Removal of compartment lid:

Remove the four screws holding compartment lid shown in Figure 3.

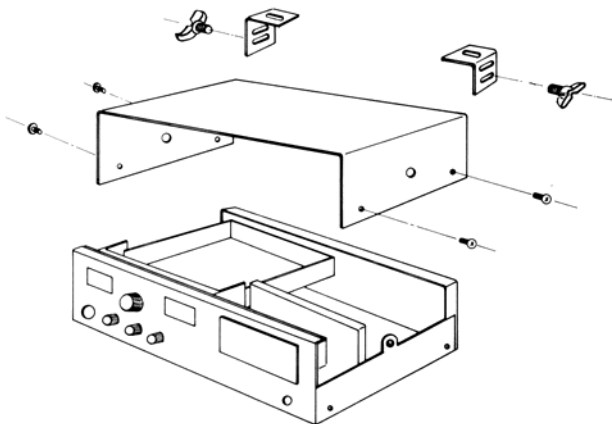

Figure 2

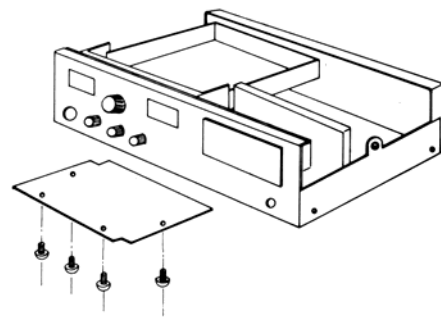

Figure 3

ALIGNMENT OF RECEIVER SECTION

EQUIPMENT REQUIRED:

Signal generator 455 kHz and 27 MHz
 Modulated 1000Hz, 30% AM
 Output Impedance 50 ohms
 VTVM
 DC power supply 13.8 Volts, 1.5A.
 Oscilloscope, Frequency Meter or Counter

NOTES:

Allow test equipment and set at least 15 minutes to warm up before starting the alignment.
 Output Level: Keep signal generator as low as possible to prevent AGC overload.
 Output level of test set should be kept under 2 volts.

Step	Connect Signal Source to—	Connect Output Indicator to—	Set Signal to—	Adjust	Adjust for—	Step
1	Set Channel Selector to Ch. #13 and DELTA TUNE to center.					1
2	Turn VR7 (Volume) fully clockwise.					2
3	Turn VR3 (Squelch) fully counterclockwise.					3
4		Oscilloscope to L904 Secondary		L901	Maximum Amplitude	4
5				L902		5
6				L903		6
7				L904		7
8	Sig. Gen. Connected to ANT. terminal	V.T.V.M. connected across ext. speaker jack 8 ohm resistive load	27.115 MHz (Modulated) Signal input should be under 50 μ V	L101	Maximum Output	8
9				L102		9
10				T301		10
11				T302		11
12				T303		12
13				T304		13
14				T305		14
15				T306		15
16	Repeat steps 8 through 15 as necessary to obtain maximum sensitivity.					16
17	Signal Gen. connected to antenna jack	V.T.V.M. connected across ext. speaker jack	27.115 MHz Signal input should be 0.25 μ V.	VR1	Adjust VR1 for 2.0 volts V.T.V.M. indication.	17
18	Same as 17	Same as 17	27.115 MHz Signal input should be 1000 μ V.	VR2	Adjust for squelch open with 1000 μ V input.	18
19	Signal Gen. connect to antenna jack (100 μ V)	8 ohm resistive load	27.115 MHz	VR4	Adjust for zero reading on the S meter.	19
20	Signal Gen. connect to antenna jack (100 μ V)	8 ohm resistive load	27.115 MHz	VR6	Adjust for S9 reading on the S meter.	20

ALIGNMENT OF TRANSMITTER SECTION

EQUIPMENT REQUIRED:

This transceiver meets all requirements of F.C.C. Rules and Regulations, Part 95. Only those persons properly licensed by the F.C.C. are permitted to repair or adjust any malfunctioning unit found to be transmitting illegally (refer to F.C.C. Rules and Regulations, Part 95, Sub part D, Section 95.)

NOTES:

Allow test equipment and set at least 15 minutes to warm up before starting the alignment.
An RF Output meter or 50 ohms non-inductive dummy load must be connected to the antenna jack.

Step	Connect Signal Source to—	Connect Output Indicator to—	Adjust	Adjust for—	Step
1	Set Channel Selector to Ch. # 13				1
2		Watt Meter across Antenna Jack or Oscilloscope may be used as the Output Indicator.	L905	Key Transmitter and adjust for Maximum Output.	2
3			L906		3
4			L907		4
5			L908		5
6			L910		6
7			L912		7
8			L913		8
9	Repeat steps 2 through 8 as necessary to obtain maximum output.				9
10	Audio Generator to microphone Jack	Oscilloscope to antenna jack and observe 80 to 100% modulation signal also watt meter across antenna jack	L910	Maximum Output	10
11	Adjust audio Signal level to obtain 80-100% modulation level.		L912		11
12			L913		12
13	Repeat steps 10 through 12 to obtain 3.5-4 watts output on all Channels.				13
14	Check R.F. deviation with Digital Frequency Counter on all Channels.				14
15	Audio Generator to microphone jack 100% modulation	Same as above	VR8	No distortion of modulation waveform at 100% modulation with 15mV input at mic jack (See Fig. 4)	15
16	No Modulation	Same as above	VR5	3.5-4.0 on the R.F. meter (depending on output obtained in step 13)	16
17	No Modulation	Frequency Monitor/ Wavemeter/Spectrum Analyzer or other type monitoring instrument across Antenna jack	L914	Minimum 54 MHz (and other spurious radiation frequencies) output	17

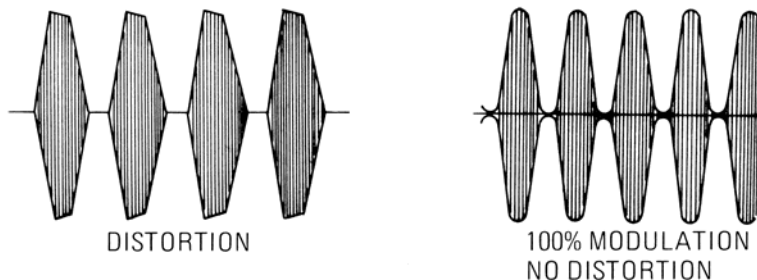
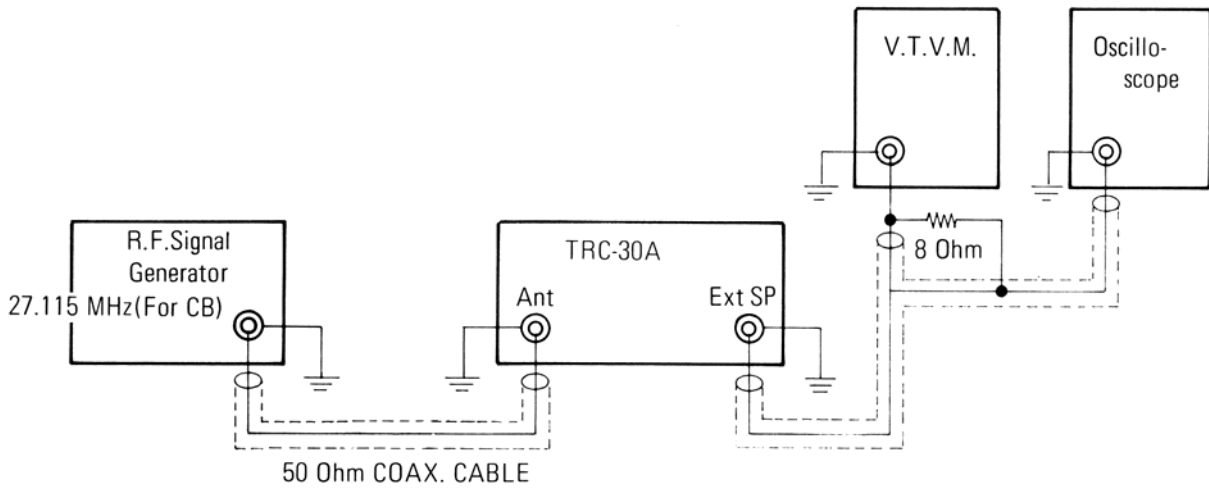
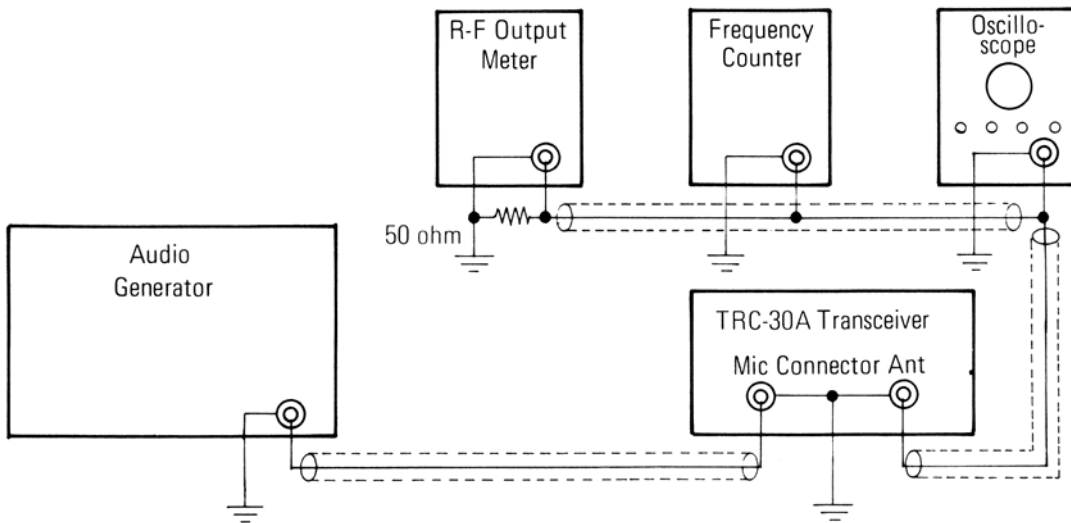

Figure 4

Receiver



Transmitter



TEST EQUIPMENT SETUP DIAGRAM

ANTENNA SYSTEM

An antenna system can be considered to include the antenna proper, the feed line, and any coupling devices used for transferring power from the transmitter to the line and from the line to the antenna. Some simple systems may omit the transmission line or one or both of the coupling devices.

Selecting an Antenna

For mobile operation at 27 MHz, the vertical whip antenna is almost universally used. Since longer whips present mechanical difficulties, the length is usually limited to a dimension that will resonate as a quarter-wave antenna in the CB band; the car body serves as the ground connection. This antenna length is approximately 8.5 feet. With the whip length adjusted to resonance in the CB band, the impedance at the feed point, X, Fig. 5, will appear as a pure resistance at the resonant frequency.

Mobile Antenna

Minimizing Losses

There is little that can be done about the nature of the coil. However, poor electrical contact between large surfaces of the car body, and especially between the point where the feed line is grounded and the rest of the body, can add materially to the ground-loss resistance. For example, the feed line, which should be grounded as close to the base of the antenna as possible, might be connected to the bumper, while the bumper may have poor contact with the rest of the body because of rust or paint.

Feeding the Antenna

It is usually found most convenient to feed the whip antenna with coax line. Unless very low-Q loading coils are used the feed-point impedance will always be appreciably lower than 52 ohms—the characteristic impedance of the commonly used coax line, RG-8/U or RG-58/U. One method of obtaining a match is shown in Fig. 6. For detailed information on precise loading and matching of Antennas and Transmission line systems, refer to the latest-edition of the **ARRL Handbook**.



Figure 5

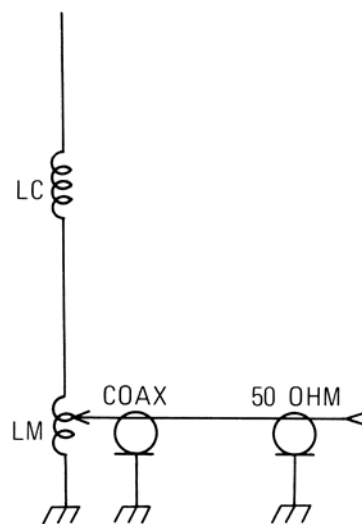
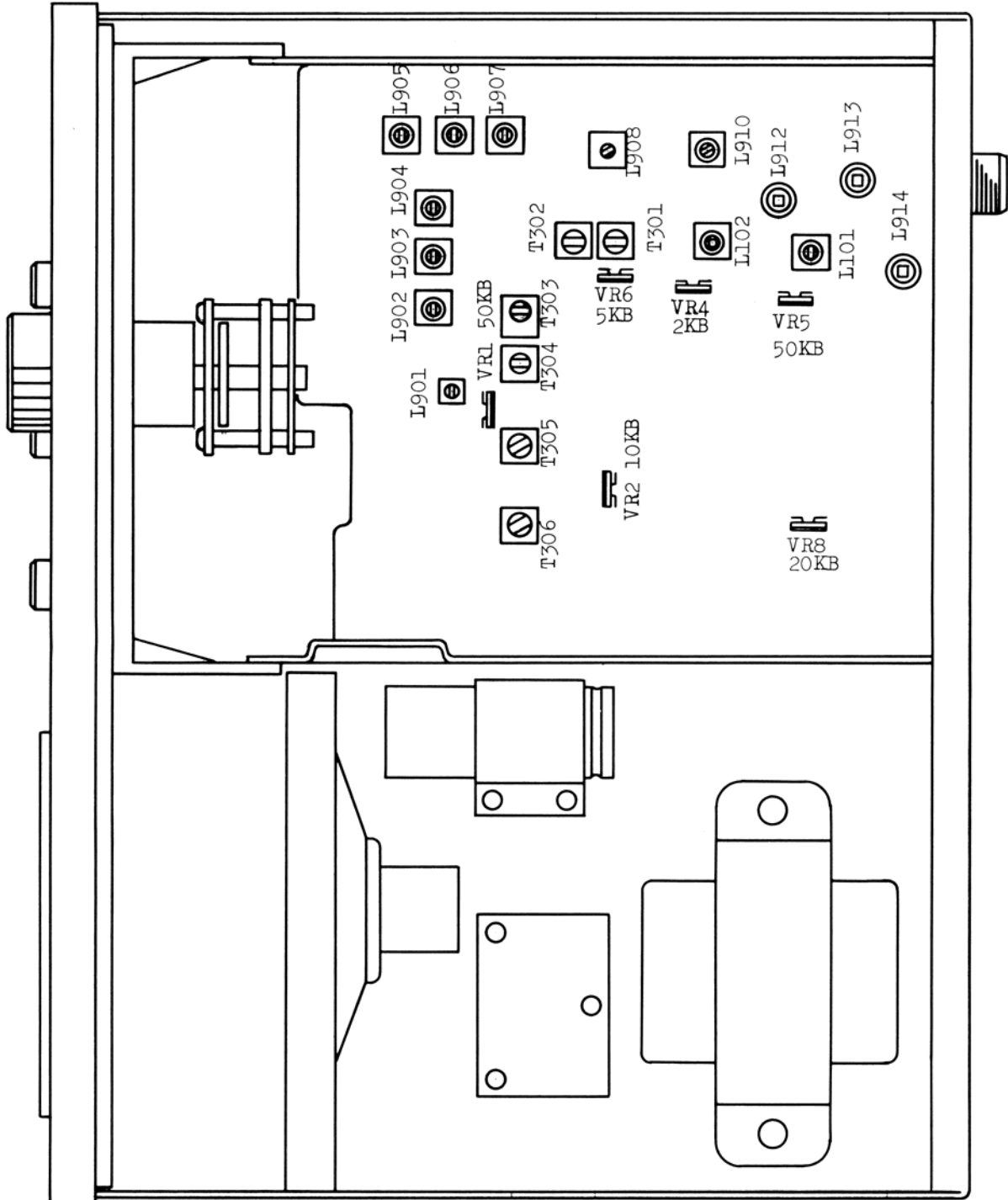

Figure 6

ALIGNMENT POINT (CHASSIS LAYOUT)



TRANSISTOR VOLTAGE CHART

1. Power supply voltage = 13.8V
2. All voltage measurements with no signal input.
3. Measured with VTVM

		RX(V)	TX(V)			RX(V)	TX(V)			RX(V)	TX(V)
Q101	B	2.2	—	Q704	B	0.63	0.63	Q907	B	—	2.5
	C	5.5	—		C	13.8	13.3		C	—	13.3
	E	1.5	—		E	—	—		E	—	1.9
Q102	B	2.2	—	Q705	B	0.63	0.63	Q908	B	—	—
	C	6.0	—		C	13.8	13.3		C	—	13
	E	1.6	—		E	—	—		E	—	0.3
Q302	B	2.2	—	Q901	B	2.0	2.0	Q909	B	—	—
	C	5.5	—		C	7.0	7.0		C	—	12.0
	E	1.6	—		E	1.5	1.5		E	—	—
Q303	B	2.2	—	Q902	B	1.5	1.5	Q501	B	0	—
	C	5.5	—		C	7.0	7.0		C	0.7	—
	E	1.6	—		E	1.0	1.0		E	6	—
Q304	B	0.7	—	Q903	B	2.4	—	Q502	B	0.7	—
	C	6.4	—		C	6.0	—		C	0	—
	E	0	—		E	1.8	—		E	0	—
Q701	B	1.8	—	Q904	B	1.6	1.4	Q507	B	—	13
	C	2.0	—		C	6.0	5.5		C	—	2.5
	E	1.2	—		E	1.0	0.9		E	—	13.6
Q702	B	2.3	2.1	Q905	B	—	3				
	C	11.0	5.6		C	—	6.3				
	E	6.0	1.5		E	—	2.5				
Q703	B	1.6	1.5	Q906	B	—	2				
	C	10.0	10.0		C	—	6.3				
	E	1.0	0.8		E	—	1.5				

CRYSTAL SYNTHESIS TABLE

Transmit/Receive						
	23.290	23.340	23.390	23.440	23.490	23.540
14.950	1	5	9	13	17	21
14.960	2	6	10	14	18	22
14.970	3	7	11	15	19	—
14.990	4	8	12	16	20	—
		2nd local	Transmit	11.275 MHz		
		1st IF	Receive	11.730 MHz		
		2nd IF		455 kHz		

SCHEMATIC DIAGRAM

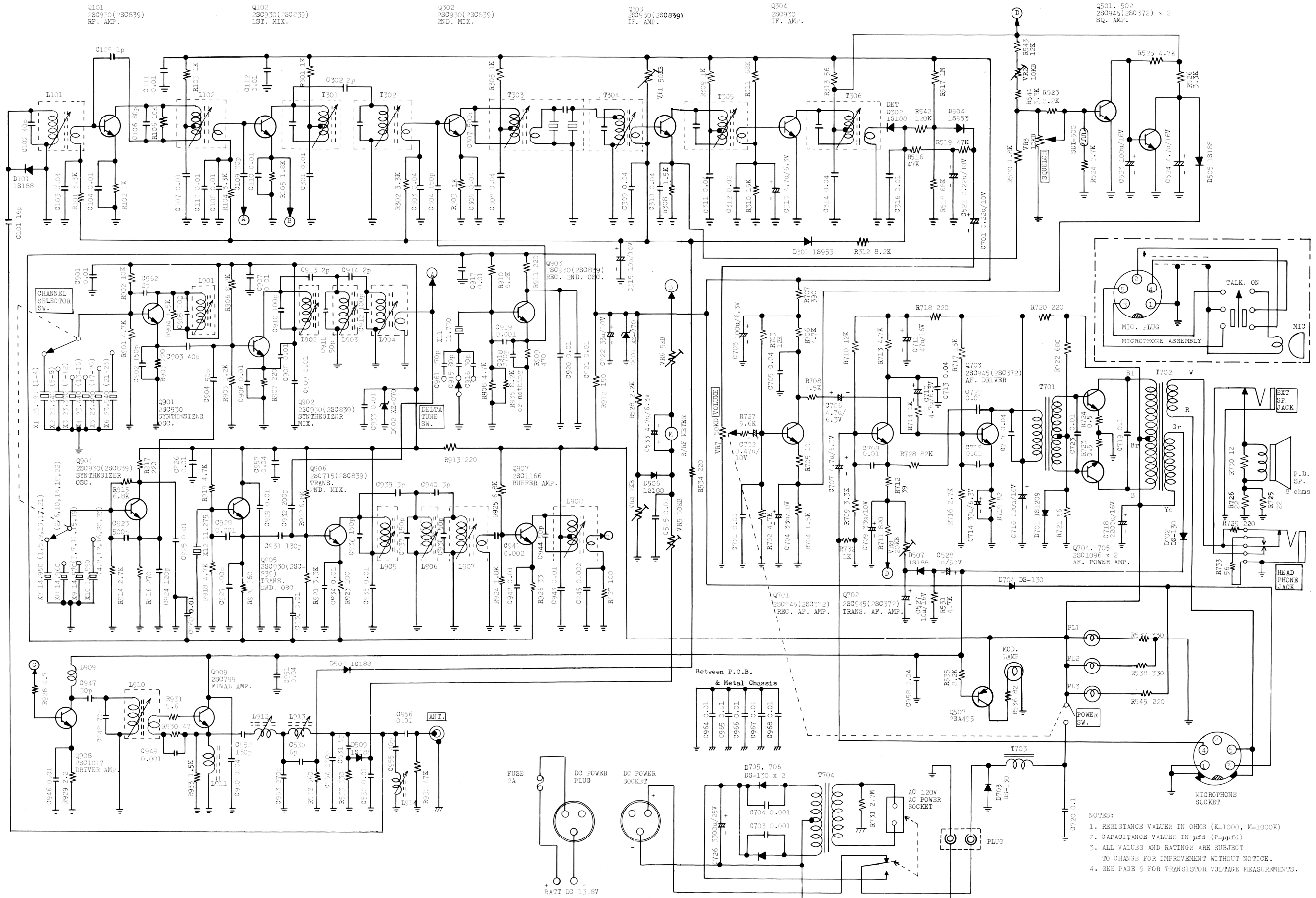

- NOTES:
1. RESISTANCE VALUES IN OHMS (K=1000, M=1000K)
 2. CAPACITANCE VALUES IN μ Fd (P-p.p.f.d)
 3. ALL VALUES AND RATINGS ARE SUBJECT TO CHANGE FOR IMPROVEMENT WITHOUT NOTICE.
 4. SEE PAGE 9 FOR TRANSISTOR VOLTAGE MEASUREMENTS.

CIRCUIT BOARD DIAGRAM (BOTTOM VIEW)

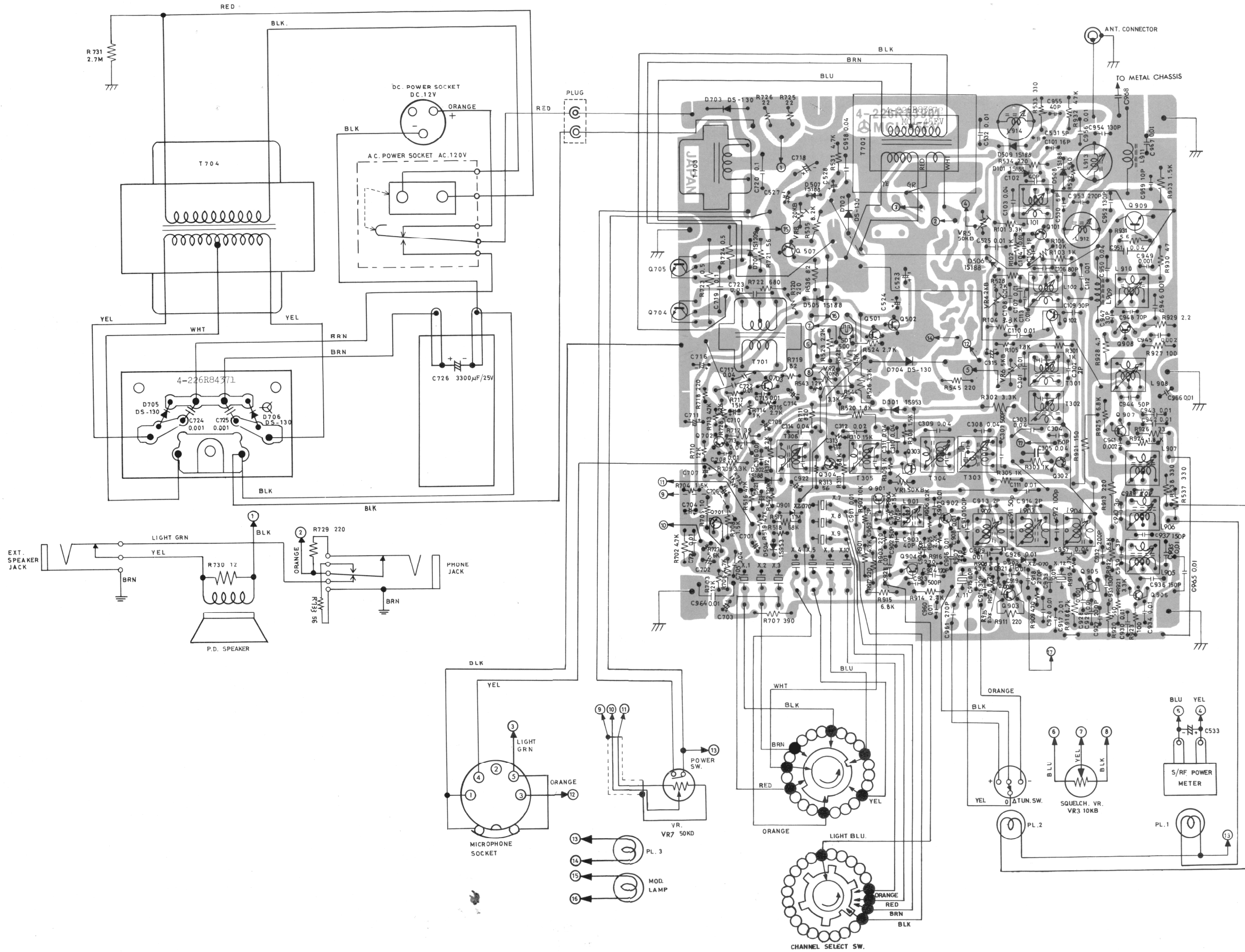

CIRCUIT BOARD DIAGRAM (TOP VIEW)

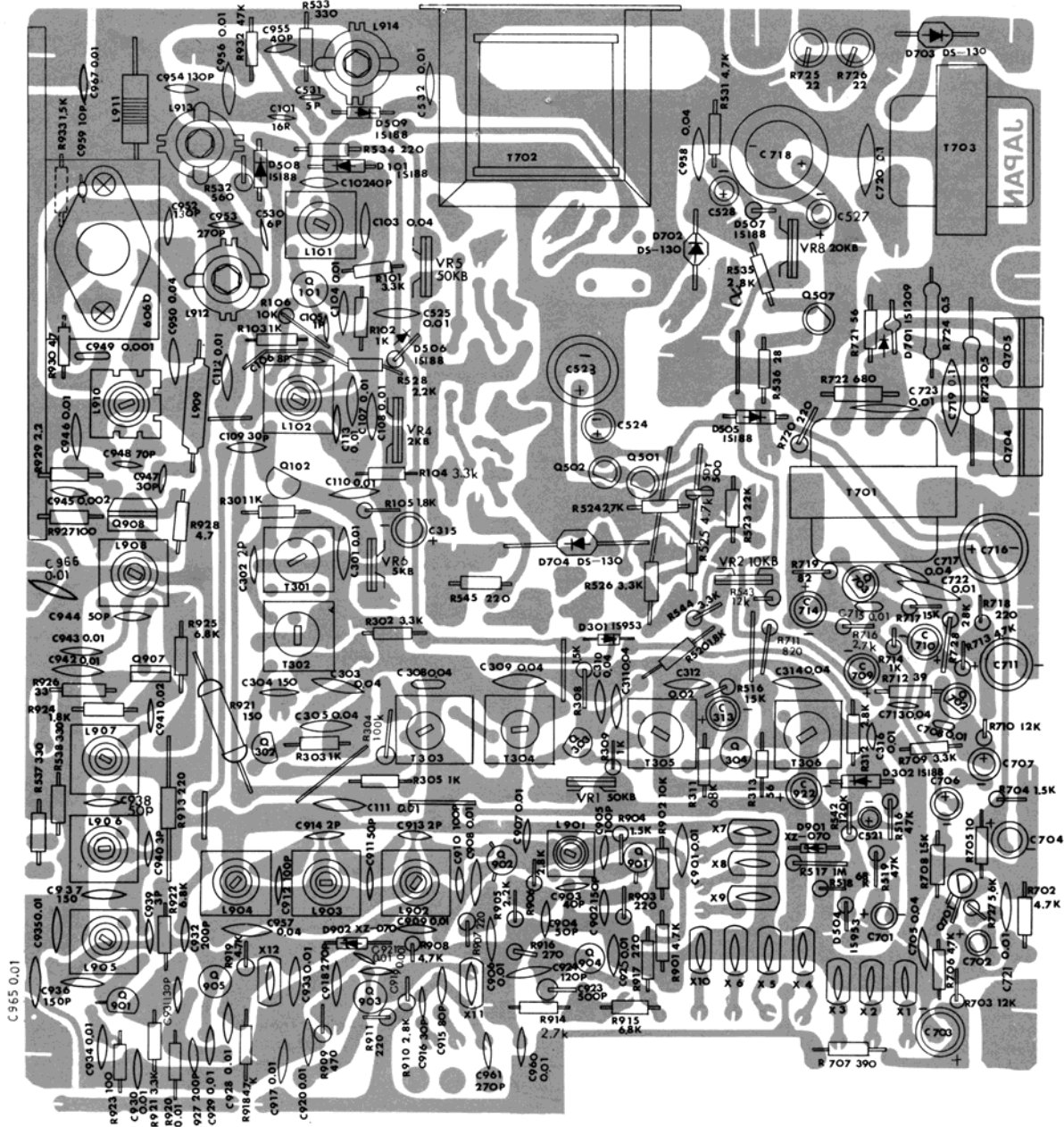

TRANSISTOR LEAD IDENTIFICATION

A	28C930, 28C715
B	28C945
C	28C1096
D	28C372, 28A495
E	28C1166
F	28C1017
G	28C799

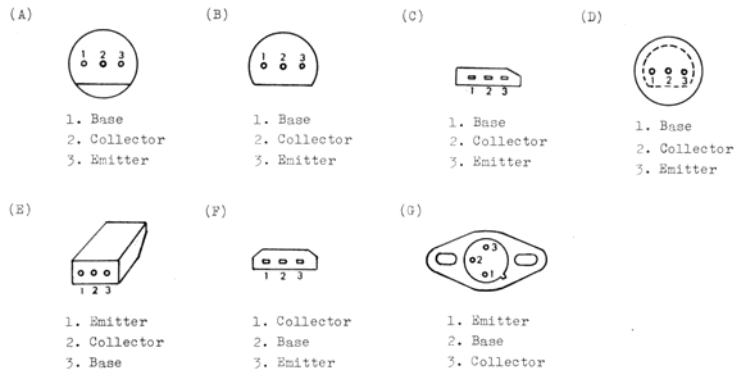

TROUBLE SHOOTING

RECEIVER SECTION

- (1) Pilot lamp does not light when power switch is turned on.
 - a. Make sure that power supply is connected with correct polarity.
 - b. Check power supply circuit for shorts.
 - c. Check power supply circuit for loose connections.
 - d. Check Diode D703.
 - e. Check fuse.
- (2) No sound (noise) from the speaker
 - a. Check with an external speaker.
 - b. See if speaker leads are broken. Also, check other leads.
 - c. Make sure that microphone switching is operating correctly.
 - d. Check to be sure the audio circuit is functioning. Check the terminal voltage of transistors Q701, Q703, Q704 and Q705.
(If you touch the terminals of volume control (VR7) with your finger, you should hear noise. Thus, you know the audio circuit is functioning.)
 - e. Make sure that Squelch circuit is operating normally.
 - f. Check for presence of 23MHz, 14MHz and 11.730MHz oscillation. If so, check that all oscillations are strong enough.
 - g. Check the connections of Channel Selector switch and Delta Tune switch.
- (3) RF meter ("S" meter) operation is abnormal.
 - a. See if the emitter voltage of Q102 corresponds to incoming signal.
 - b. Check connections of R530 and R527.
 - c. Check C533 for a short.

TRANSMITTER SECTION

- (1) No output
 - a. Insure microphone plug is inserted correctly.
 - b. Try replacing the microphone.
 - c. Check for the presence of 23MHz, 14MHz and 11MHz oscillation. If so, are they strong enough ?
 - d. Make sure PA switch is not pushed to PA position.
 - e. Check that each transistor is operating normally.
- (2) No Modulation (Modulation lamp does not light)
 - a. Make sure the direct current resistance of the third coil of modulation transformer (T702) is from 1 to 1.2 ohm.
 - b. Try replacing the microphone.
 - c. Check the terminal voltages of Q702.
 - d. Check values of C708 and C528.
 - e. Check values of C709, C710 and C707.

NO RECEIVING AND NO TRANSMITTING

- (1) Check microphone circuit.
- (2) Check for presence of 23MHz and 14MHz oscillation.
- (3) Check circuit voltages of Q901 and Q904.
- (4) Check voltages of Q902.
- (5) Check wire leads of coil L902, L903 and L904.

REPLACEMENT PARTS LIST

Symbol No.	Description	RS Part No.	Mfr's Part No.	Symbol No.	Description	RS Part No.	Mfr's Part No.
CAPACITORS				CAPACITORS			
C101	16 pfd ±5% 50V Ceramic		R-CKD160J	C313	4.7 mfd 6.3V Electrolytic		R-C9882
C102	40 pfd ±5% 50V Ceramic		R-CKD400J	C314	0.04 mfd ±20% 50V Ceramic		R-CKD403M
C103	0.04 mfd ±20% 50V Ceramic		R-CKD403M	C315	10 mfd 16V Electrolytic		R-C9889
C104	0.01 mfd ±20% 50V Ceramic		R-CKD103M	C316	0.01 mfd ±20% 50V Mylar		R-CQS103M
C105	1 pfd ±0.25 pfd 50V Ceramic		R-CKD010C	C521	0.22 mfd 10V Electrolytic		R-C9120
C106	80 pfd ±5% 50V Ceramic		R-CKD800J	C523	100 mfd 16V Electrolytic		R-C9907
C107	0.01 mfd ±20% 50V Ceramic		R-CKD103M	C524	4.7 mfd 16V Electrolytic		R-C9883
C108	0.01 mfd ±20% 50V Ceramic		R-CKD103M	C525	0.01 mfd ±20% 50V Ceramic		R-CKD103M
C109	30 pfd ±5% 50V Ceramic		R-CKD300J	C527	10 mfd 16V Electrolytic		R-C9889
C110	0.01 mfd ±20% 50V Ceramic		R-CKD103M	C528	1 mfd 50V Electrolytic		R-C9235
C111	0.01 mfd ±20% 50V Ceramic		R-CKD103M	C530	6 pfd ±0.25 pfd 50V Ceramic		R-CKD060C
C112	0.01 mfd ±20% 50V Ceramic		R-CKD103M	C531	5 pfd ±0.25 pfd 50V Ceramic		R-CKD050C
C113	0.01 mfd +80%–20% 50V Ceramic		R-CKD103Z	C532	0.01 mfd ±20% 50V Ceramic		R-CKD103M
C301	0.01 mfd ±20% 50V Ceramic		R-CKD103M	C533	4.7 mfd 6.3V Electrolytic		R-C9882
C302	2 pfd ±0.25 pfd 50V Ceramic		R-CKD20C	C701	0.22 mfd 10V Electrolytic		R-C9120
C303	0.04 mfd ±20% 50V Ceramic		R-CKD403M	C702	0.47 mfd 10V Electrolytic		
C304	150 pfd ±5% 50V Ceramic		R-CKD151J	C703	100 mfd 6.3V Electrolytic		
C305	0.04 mfd ±20% 50V Ceramic		R-CKD403M	C704	33 mfd 10V Electrolytic		R-C9934
C307	500 pfd ±10% 50V Styrol		R-CQA501K	C705	0.04 mfd ±20% 50V Ceramic		R-CKD403M
C308	0.04 mfd ±20% 50V Mylar		R-CQS403M	C706	4.7 mfd 6.3V Electrolytic		R-C9882
C309	0.04 mfd ±20% 50V Ceramic		R-CKD403M	C707	4.7 mfd 6.3V Electrolytic		R-C9882
C310	0.04 mfd ±20% 50V Ceramic		R-CKD403M	C708	0.01 mfd ±20% 50V Mylar		R-CQS103M
C311	0.04 mfd ±20% 50V Ceramic		R-CKD403M	C709	33 mfd 10V Electrolytic		R-C9934
C312	0.04 mfd ±20% 50V Ceramic		R-CKD403M	C710	4.7 mfd 6.3V Electrolytic		R-C9882

Symbol No.	Description	RS Part No.	Mfr's Part No.	Symbol No.	Description	RS Part No.	Mfr's Part No.
CAPACITORS				CAPACITORS			
C711	47 mfd 16V Electrolytic		R-C9886	C910	100 pfd ±5% 50V Ceramic		R-CKD101J
C713	0.04 mfd +80%–20% 50V Ceramic		R-CKD403Z	C911	50 pfd ±5% 50V Ceramic		R-CKD500J
C714	33 mfd 6.3V Electrolytic		R-C9881	C912	100 pfd ±5% 50V Ceramic		R-CKD101J
C715	0.01 mfd ±20% 50V Mylar		R-CQS103M	C913	2 pfd ±0.25 pfd 50V Ceramic		R-CKD020C
C716	220 mfd 16V Electrolytic		R-C9877	C914	2 pfd ±0.25 pfd 50V Ceramic		R-CKD020C
C717	0.04 mfd ±20% 50V Mylar		R-CQS403M	C915	80 pfd ±5% 50V Ceramic		R-CKD800J
C718	2200 mfd 16V Electrolytic			C916	40 pfd ±5% 50V Ceramic		R-CKD400J
C719	0.1 mfd +80%–20% 50V Ceramic		R-CKD104Z	C917	0.01 mfd ±20% 50V Ceramic		R-CKD103M
C720	0.1 mfd +80%–20% 50V Ceramic		R-CKD104Z	C918	270 pfd ±5% 50V Ceramic		R-CKD271J
C721	0.01 mfd ±20% 50V Ceramic		R-CKD103M	C919	0.001 mfd ±5% 50V Ceramic		R-CKD102J
C722	0.01 mfd ±20% 50V Ceramic		R-CKD103M	C920	0.01 mfd ±20% 50V Ceramic		R-CKD103M
C723	0.01 mfd ±20% 50V Mylar		R-CQS103M	C921	0.01 mfd +80%–20% 50V Ceramic		R-CKD103Z
C724	0.001 mfd +100%–20% Ceramic 150V		R-CKD102P	C922	33 mfd 10V Electrolytic		R-C9934
C725	0.001 mfd +100%–20% Ceramic 150V		R-CKD102P	C923	500 pfd ±10% 50V Styrol		R-CQA501K
C726	3300 mfd 25V Electrolytic		4-223R803	C924	120 pfd ±5% 50V Ceramic		R-CKD121J
C901	0.01 mfd ±20% 50V Ceramic		R-CKD103M	C925	0.01 mfd ±20% 50V Ceramic		R-CKD103M
C902	150 pfd ±5% 50V Ceramic		R-CKD151J	C926	0.01 mfd +80%–20% 50V Ceramic		R-CKD103Z
C903	40 pfd ±5% 50V Ceramic		R-CKD400J	C927	200 pfd ±5% 50V Ceramic		R-CKD201J
C904	50 pfd ±5% 50V Ceramic		R-CKD500J	C928	0.001 mfd ±5% 50V Ceramic		R-CKD102J
C905	100 pfd ±5% 50V Ceramic		R-CKD101J	C929	0.01 mfd ±20% 50V Ceramic		R-CKD103M
C906	0.01 mfd ±20% 50V Ceramic		R-CKD103M	C930	0.01 mfd ±20% 50V Ceramic		R-CKD103M
C907	0.01 mfd +80%–20% 50V Ceramic		R-CKD103Z	C931	130 pfd ±5% 50V Ceramic		R-CKD131J
C908	0.01 mfd ±20% 50V Ceramic		R-CKD103M	C932	200 pfd ±5% 50V Ceramic		R-CKD201J
C909	0.01 mfd ±20% 50V Ceramic		R-CKD103M	C933	0.01 mfd ±20% 50V Ceramic		R-CKD103M

Symbol No.	Description	RS Part No.	Mfr's Part No.	Symbol No.	Description	RS Part No.	Mfr's Part No.
CAPACITORS				CAPACITORS			
C934	0.01 mfd ±20% Ceramic		R-CKD103M	C958	0.04 mfd ±20% Ceramic		R-CKD403M
C935	0.01 mfd ±20% Ceramic		R-CKD103M	C959	10 pfd ±5% Ceramic		R-CKD100J
C936	150 pfd ±5% Ceramic		R-CKD151J	C960	0.01 mfd +80%–20% Ceramic		R-CKD103Z
C937	150 pfd ±5% Ceramic		R-CKD151J	C961	270 pfd ±5% Ceramic		R-CKD271J
C938	50 pfd ±5% Ceramic		R-CKD500J	C962	2 pfd ±0.25 pfd Ceramic		R-CKD020C
C939	3 pfd ±0.25 pfd Ceramic		R-CKD030C	C964	0.01 mfd ±20% Ceramic		R-CKD103M
C940	3 pfd ±0.25 pfd Ceramic		R-CKD030C	C965	0.01 mfd ±20% Ceramic		R-CKD103M
C941	0.002 mfd ±10% Ceramic		R-CKD202K	C966	0.01 mfd ±20% Mylar		R-CQS103M
C942	0.01 mfd ±20% Ceramic		R-CKD103M	C967	0.01 mfd ±20% Mylar		R-CQS103M
C943	0.01 mfd ±20% Ceramic		R-CKD103M	C968	0.01 mfd ±20% Ceramic		R-CKD103M
C944	50 pfd ±5% Ceramic		R-CKD500J	SEMI-CONDUCTORS			
C945	0.002 mfd ±10% Ceramic		R-CKD202K	D101	1S188 FM Diode		1S188
C946	0.01 mfd ±20% Ceramic		R-CKD103M	D301	1S953 Diode		1S953
C947	30 pfd ±5% Ceramic		R-CKD300J	D302	1S188 AM Diode		1S188
C948	70 pfd ±5% Ceramic		R-CKD700J	D504	1S953 Diode		1S953
C949	0.001 mfd ±20% Mylar		R-CSQ102M	D505	1S188 AM Diode		1S188
C950	0.04 mfd ±20% Ceramic		R-CKD403M	D506	1S188 FM Diode		1S188
C951	0.04 mfd ±20% Ceramic		R-CKD403M	D507	1S188 AM Diode		1S188
C952	130 pfd ±5% Ceramic		R-CKD131J	D508	1S188 AM Diode		1S188
C953	270 pfd ±5% Ceramic		R-CKD271J	D509	1S188 AM Diode		1S188
C954	130 pfd ±5% Ceramic		R-CKD131J	D701	1S1209 Varistor		1S1209
C955	40 pfd ±5% Ceramic		R-CKD400J	D702	DS-130 E Diode		DS-130
C956	0.01 mfd ±20% Ceramic		R-CKD103M	D703	DS-130 E Diode		DS-130
C957	0.04 mfd ±20% Ceramic		R-CKD403M	D704	DS-130 E Diode		DS-130
				D705	DS-130 B.C Diode		DS-130
				D706	DS-130 B.C Diode		DS-130
				D901	XZ070 Diode		XZ070
				D902	XZ070 Diode		XZ070
				R936	SDT-500 Thermistor		SDT-500

Symbol No.	Description	RS Part No.	Mfr's Part No.	Symbol No.	Description	RS Part No.	Mfr's Part No.
COILS				TRANSISTORS & CRYSTALS			
L101	Antenna Coil	CA-2991	4-257R326		Crystal 23.390MHz HC-18U		4-255R811
L102	RF Coil	CA-4498	4-259R828		Crystal 23.440MHz HC-18U		4-225R812
L901	OSC Coil	CA-4509	4-258R813A		Crystal 23.490MHz HC-18U		4-225R813
L902	RF Coil	CA-4499	4-259R825		Crystal 23.540MHz HC-18U		4-225R814
L903	RF Coil	CA-4500	4-259R826		Crystal 14.950MHz HC-18U		4-225R805
L904	RF Coil	CA-4501	4-259R827		Crystal 14.960MHz HC-18U		4-225R806
L905	RF Coil	CA-4502	4-259R801		Crystal 14.970MHz HC-18U		4-225R807
L906	RF Coil	CA-4502	4-259R801		Crystal 14.990MHz HC-18U		4-225R808
L907	RF Coil	CA-4503	4-259R802		Crystal 11.730MHz HC-18U		4-225R803
L908	RF Coil	CA-4504	4-259 R10904A		Crystal 11.275MHz HC-18U		4-225R804
L909	RF Choke Coil	CB-2206	4-253R701	RESISTORS			
L910	RF Coil	CA-4508	4-259R823	R101	3.3 Kohm ±10% ¼W		R-R332KB
L911	Choke Coil	CB-2207	4-255R103	R102	1 Kohm ±10% ¼W		R-R102KB
L912	RF Coil	CA-4505	4-259R805	R103	1 Kohm ±10% ¼W		R-R102KB
L913	RF Coil	CA-4506	4-259R806	R104	3.3 Kohm ±10% ¼W		R-R332KB
L914	RF Coil	CA-4507	4-259R807	R105	1.8 Kohm ±10% ¼W		R-R182KB
TRANSISTORS & CRYSTALS				R106	10 Kohm ±10% ¼W		R-R103KB
Q101	2SC930 D Transistor		2SC930	R301	1 Kohm ±10% ¼W		R-R102KB
Q102	2SC839 H Transistor		2SC839	R302	3.3 Kohm ±10% ¼W		R-R332KB
Q302	2SC930 D Transistor		2SC930	R303	1 Kohm ±10% ¼W		R-R102KB
Q303	2SC930 D Transistor		2SC930	R305	1 Kohm ±10% ¼W		R-R102KB
Q304	2SC930 D Transistor		2SC930	R308	1.5 Kohm ±10% ¼W		R-R152KB
Q501	2SC372 Y or Transistor		2SC372 or	R309	1 Kohm ±10% ¼W		R-R102KB
	2SC945 R or Q		2SC945	R310	15 Kohm ±10% ¼W		R-R153KB
Q502	2SC372 Y or Transistor		2SC372 or	R311	68 Kohm ±10% ¼W		R-R683KB
	2SC945 R or Q		2SC945	R312	8.2 Kohm ±10% ¼W		R-R822KB
Q507	2SA495 O Transistor		2SA495	R313	56 ohm ±10% ¼W		R-R560KB
Q701	2SC372 Y or Transistor		2SC372 or	R337	330 ohm ±10% ¼W		R-R331KB
	2SC945 R or Q		2SC945	R516	47 Kohm ±10% ¼W		R-R473KB
Q702	2SC372 Y or Transistor		2SC372 or	R517	1 Mohm ±10% ¼W		R-R105KB
	2SC945 R or Q		2SC372	R518	68 Kohm ±10% ¼W		R-R683KB
Q703	2SC372 Y or Transistor		2SC372 or	R519	47 Kohm ±10% ¼W		R-R473KB
	2SC945 R or Q		2SC945	R520	1.8 Kohm ±10% ¼W		R-R182KB
Q704	2SC1096 4ZL Transistor		2SC1096	R523	2.2 Kohm ±10% ¼W		R-R222KB
Q705	2SC1096 4ZL Transistor		2SC1096	R524	2.7 Kohm ±10% ¼W		R-R272KB
Q901	2SC930 D Transistor		2SC930	R525	4.7 Kohm ±10% ¼W		R-R472KB
Q902	2SC930 E Transistor		2SC930	R526	3.3 Kohm ±10% ¼W		R-R332KB
Q903	2SC930 D Transistor		2SC930	R528	2.2 Kohm ±10% ¼W		R-R222KB
Q904	2SC930 D Transistor		2SC930	R531	4.7 Kohm ±10% ¼W		R-R472KB
Q905	2SC930 E Transistor		2SC930	R532	560 ohm ±10% ¼W		R-R561KB
Q906	2SC839 H Transistor		2SC839	R533	330 ohm ±10% ¼W		R-R331KB
Q907	2SC1166 O Transistor		2SC1166	R534	220 ohm ±10% ¼W		R-R221KB
Q908	2SC1017 Transistor		2SC1017	R535	8.2 Kohm ±10% ¼W		R-R822KB
Q909	2SC799 Transistor		2SC799	R536	82 ohm ±10% ¼W		R-R820KB
	Crystal 23.290MHz HC-18U		4-225R809	R537	330 ohm ±10% ¼W		R-R331KB
	Crystal 23.340MHz HC-18U		4-225R810	R538	330 ohm ±10% ¼W		R-R331KB
				R542	120 Kohm ±10% ¼W		R-R124KB

Symbol No.	Description	RS Part No.	Mfr's Part No.	Symbol No.	Description	RS Part No.	Mfr's Part No.
RESISTORS				RESISTORS			
R543	12 Kohm ±10% ¼W		R-R123KB	R916	270 ohm ±10% ¼W		R-R271KB
R544	3.3 Kohm ±10% ¼W		R-R332KB	R917	220 ohm ±10% ¼W		R-R221KB
R545	220 ohm ±10% ¼W		R-R221KB	R918	4.7 Kohm ±10% ¼W		R-R472KB
R702	4.7 Kohm ±10% ¼W		R-R472KB	R919	4.7 Kohm ±10% ¼W		R-R472KB
R703	12 Kohm ±10% ¼W		R-R123KB	R920	560 ohm ±10% ¼W		R-R561KB
R704	1.5 Kohm ±10% ¼W		R-R152KB	R921	3.3 Kohm ±10% ¼W		R-R332KB
R705	10 ohm ±10% ¼W		R-R100KB	R922	6.8 Kohm ±10% ¼W		R-R682KB
R706	4.7 Kohm ±10% ¼W		R-R472KB	R923	100 ohm ±10% ¼W		R-R101KB
R707	390 ohm ±10% ¼W		R-R391KB	R924	1.8 Kohm ±10% ¼W		R-R182KB
R708	1.5 Kohm ±10% ¼W		R-R152KB	R925	6.8 Kohm ±10% ¼W		R-R682KB
R709	3.3 Kohm ± 5% ¼W		R-R332JB	R926	33 ohm ±10% ¼W		R-R330KB
R710	12 Kohm ± 5% ¼W		R-R123JB	R927	100 ohm ±10% ¼W		R-R101KB
R711	820 ohm ± 5% ¼W		R-R821JB	R928	4.7 ohm ±10% ¼W		R-R0470KB
R712	39 ohm ±10% ¼W		R-R390KB	R929	2.2 ohm ±10% ¼W		R-R0220KB
R713	4.7 Kohm ±10% ¼W		R-R472KB	R930	47 ohm ±10% ¼W		R-R470KB
R714	1 Kohm ±10% ¼W		R-R102KB	R931	5.6 ohm ±10% ¼W		R-R0560KB
R716	2.7 Kohm ±10% ¼W		R-R272KB	R932	47 Kohm ±10% ¼W		R-R473KB
R717	15 Kohm ±10% ¼W		R-R153KB	R933	1 Kohm ±10% ¼W		R-R102KB
R718	220 ohm ±10% ¼W		R-R221KB	R935	8.2 Kohm ±10% ¼W		R-R822KB
R719	82 ohm ±10% ¼W		R-R820KB	POTENTIOMETERS			
R720	220 ohm ±10% ¼W		R-R221KB	VR1	Semi Variable Resistor 50KB	P-6203	R-R11010
R721	56 ohm ± 5% ¼W		R-R560JB	VR2	Semi Variable Resistor 10KB	P-6202	R-R11013
R722	680 ohm ± 5% ½W		R-R681JC	VR3	Variable Resistor 10KB	P-0742	4-222R512
R723	0.5 ohm ± 5% ½W		R-R0050JC	VR4	Semi Variable Resistor 2KB	P-6200	R-R110809
R724	0.5 ohm ± 5% ½W		R-R0050JC	VR5	Semi Variable Resistor 50KB	P-6203	R-R11010
R725	22 ohm ± 5% 2W		R-R220JE	VR6	Semi Variable Resistor 5KB	P-6201	R-R11012
R726	22 ohm ± 5% 2W		R-R220JE	VR7	Variable Resistor 50KD 24φ		4-222R516
R727	5.6 Kohm ±10% ¼W		R-R562KB	VR8	Semi Variable Resistor 20KB		R-R11016
R728	82 Kohm ±10% ¼W		R-R823KB	TRANSFORMERS			
R729	220 ohm ±10% ¼W		R-R221KB	T301	IFT	CA-7438	4-256R717
R730	12 ohm ± 5% 1W		R-R120JD	T302	IFT	CA-7439	4-256R714
R731	2.7 Mohm ±10% ½W		R-R275KC	T303	HF Filter	C-0540	4-256R197
R732	1 Kohm ±10% ¼W		R-R102KB	T304	IFT	CA-7352	4-256R198
R733	56 ohm ±10% ¼W		R-R560KB	T305	IFT	CA-7350	4-256R703
R901	4.7 Kohm ±10% ¼W		R-R472KB	T306	IFT	CA-7351	4-256R711
R902	10 Kohm ±10% ¼W		R-R103KB	T701	IPT	TN-0066	4-254R118
R903	220 ohm ±10% ¼W		R-R221KB	T702	OPT	TD-0119	4-254R80471
R904	1.5 Kohm ±10% ¼W		R-R152KB	T703	Choke Coil	CB-2208	4-255R102
R905	2.2 Kohm ±10% ¼W		R-R222KB	T704	PT	TA-0454	4-251R807 or 4-251R80701
R906	8.2 Kohm ±10% ¼W		R-R822KB	for Cabinet Assembly			
R907	220 ohm ±10% ¼W		R-R221KB	SP.	Speaker, 8 ohm 1.5W	S-4517	4-151R806
R908	4.7 Kohm ±10% ¼W		R-R472KB	Mic.	Microphone	M-0253	4-153R804
R909	470 ohm ±10% ¼W		R-R471KB		Top Lid	Z-2109	176-2-124R105A
R910	8.2 Kohm ±10% ¼W		R-R822KB		Compartment Lid	Z-2110	176-2-123R102
R911	220 ohm ±10% ¼W		R-R221KB				
R912	150 ohm ±10% 2W		R-R151KE				
R913	220 ohm ±10% ¼W		R-R221KB				
R914	2.7 Kohm ±10% ¼W		R-R272KB				
R915	6.8 Kohm ±10% ¼W		R-R682KB				

Symbol No.	Description	RS Part No.	Mfr's Part No.	Symbol No.	Description	RS Part No.	Mfr's Part No.
for Cabinet Assembly				for Cabinet Assembly			
	Label	HB-1557	176-6-472R132		Rotary Switch for Delta Tuning	S-1154	4-231R505A
	Rotary Knob Assembly for CH. SEL.	K-1685	176-0-163R112		Socket for PHONE Jack	J-6278	4-235R809
	Rotary Knob Assembly for VOL/SQ	K-1686	176-0-163R10901		Socket for AC	J-6279	4-235T247A
	Bracket for mobile installation	MB-0107	176-2-310R147		Power Cord Assembly, UL		4-243T745
	Microphone Hanger	M-3072	176-2-331R102		Power Cord Assembly, CSA		4-243T745
	Chassis		176-2-312R1020-1		Heat Sink, (Q704, Q705)	HH-0116	176-2-368R106
	Sub Chassis		176-2-312R102A		Heat Sink, (Q909)	HH-0117	176-2-368R112B
	Fixer for controls Mtg.	HB-1560	176-2-464R116B		Fuse, 2A	HF-0087	4-234R809
	PC Board for Main		4-226R83972		Fuse Holder		123-2-283R104
	PC Board for Rectifier		4-226R4371		Terminal for binding AC lead	J-0614	123-2-382R112
	Marking Plate		176-2-143R13801		Lamp, 6V/21mA, PL1, PL2, PL3, PL4	L-0499	4-612R806
	Bracket for Speaker Mtg.	HB-1562	176-2-310R146		Socket for B line connection		4-235R819
	Escutcheon	Z-2114	176-2-153R112		Plug for B line connection		4-236R810
	Bracket for holding Fixer	HB-1555	176-2-310R145		Terminal for binding AC lead	J-0614	123-2-382R112
	Dial Scale for CH. SEL.	G-0180	176-2-146R106A		Terminal for Test Point	J-0613	123-2-382R00292
	Insert Nut		176-2-413R108		Screw, 3x10mm, Stand Mtg.		R-Y013010
	Bracket for C726 Mtg.	HB-1563	176-2-310R138		Screw, 4x12mm, Transformer Mtg.		R-Y014012
	Joint for CH. SEL.	HB-1564	176-2-253R102		Washer, 4mm, Transformer Mtg.		R-Y334000
	Clear Window for TRANSMIT	G-0179	176-2-132R107		Washer, 4mm, Transformer Mtg.		R-Y324000
	Cover for TRANSMIT	HB-1551	176-2-135R125		Nut, 4mm, Transformer Mtg.		R-Y23400001
	Marking Plate for TRANSMIT		176-2-143R137		Screw, 2.6x10mm, Socket Mtg.		R-Y012610
	Bracket for Transmit Indicator	HB-1553	176-2-310R144		Nut, 3mm, Socket Mtg.		R-Y23300001
	Cover for Transmit Indicator	HB-1554	176-2-135R127		Screw, 3x6mm, Lug Mtg.		R-Y013006
	Cover for AC Socket	HB-1558	176-2-135R128		Nut, 3mm, Lug Mtg.		R-Y233000001
	Rubber Cushion		176-2-445R133		Screw, 3x6mm, PC Board Mtg.		R-Y013006
	Rating Plate		176-2-141R13701		Washer, 3mm, PCB Mtg.		R-Y34300002
	Stand		141R174T802		Screw, 3x6mm, Transformer Mtg.		R-Y013006
	Stud Nut		123-2-417R012		Washer, 3mm, Transformer Mtg.		R-Y323000
	Bracket for PHONE Jack installation, inside chassis		176-2-210R117		Washer, 3mm, Transformer Mtg.		R-Y34300002
	Bracket for PHONE Jack installation, outside chassis		176-2-210R116		Nut, 3mm, Transformer Mtg.		R-Y23300001
	Lug for ground		123-2-472R004		Screw, 2.6x8mm, Chassis Mtg.		R-Y012608
	Lug for wiring		123-2-472R006		Nut, 3mm, Heat Sink Mtg.		R-Y23300001
	Fixer for wiring		141-2-464T087		Screw, 3x6mm, Heat Sink Mtg.		R-Y013006
	Chassis for Main PC Board		176-2-311R11001A		Screw, 3x6mm, Heat Sink Mtg.		R-Y013006
	Bracket for Transformer Mtg.		176-2-310R161		Screw, 3x10mm, 2SC799 Mtg.		R-Y013010
	Instruction Manual		176-6-411R14101		Nut, 3mm, 2SC799 Mtg.		R-Y23300001
	Display Carton		176-6-141R14601		Screw, 3 x 10mm, Stand Mtg.		R-Y013010
	Socket for Ext. SP.	J-6275	4-235R002		Screw, 4x12mm, Transformer Mtg.		R-Y014012
	Receptacle for Ant.	J-6255	4-235R806		Washer, 4mm, Transformer Mtg.		R-Y334000
	Socket for Microphone	J-6256	4-235R101A		Washer, 4mm, Transformer Mtg.		R-Y324000
	Plug for Microphone	J-6257	4-236R803		Nut, 4mm, Transformer Mtg.		R-Y23400001
	Socket for DC		4-235R817		Screw, 2,6x10mm, Socket Mtg.		R-Y012610
	Plug for DC	J-6281	4-612R806		Nut, 3mm, Socket Mtg.		R-Y23300001
	Meter	M-0252	4-551R803		Screw, 3x6mm, Lug Mtg.		R-Y013006
	Rotary Switch for Ch. Sel.	S-1138	4-231R504				

Symbol No.	Description	RS Part No.	Mfr's Part No.	Symbol No.	Description	RS Part No.	Mfr's Part No.
for Cabinet Assembly				for Cabinet Assembly			
	Nut, 3mm, Lug Mtg.		R-Y233000001		Screw, 3x10mm, 2SC799 Mtg.		R-Y013010
	Screw, 3x6mm, PC Board Mtg.		R-Y013006		Nut, 3mm, 2SC799 Mtg.		R-Y23300001
	Washer, 3mm, PCB Mtg.		R-Y34300002		Screw, 2.6x6mm, Lug Mtg.		R-Y012606
	Screw, 3x6mm, Transformer Mtg.		R-Y013006		Washer, 3mm, Stand Mtg.		R-Y323000
	Washer, 3mm, Transformer Mtg.		R-Y323000		Washer, 3mm, PC Board Mtg.		R-Y34300002
	Washer, 3mm, Transformer Mtg.		R-Y34300002		Washer, 3mm, Chassis Mtg.		R-Y333000
	Nut, 3mm, Transformer Mtg.		R-Y23300001		Washer, 3mm, Electrolytic Capacitor Mtg.		R-Y333000
	Screw, 2.6x8mm, Chassis Mtg.		R-Y012608		Washer, 3mm, Lug Mtg.		R-Y333000
	Nut, 3mm, Heat Sink Mtg.		R-Y23300001		Washer, 2.6mm, Chassis Mtg.		R-Y323600
	Screw, 3x6mm, Heat Sink Mtg.		R-Y013006		Screw, 3mm, Lug Mtg.		R-Y013000
	Screw, 3x6mm, Heat Sink Mtg.		R-Y013006		Washer, 3mm, Lug Mtg.		R-Y333000
	Nut, 3mm, Heat Sink Mtg.		R-Y23300001		Screw, 3x8mm, Fixer Mtg.		R-Y013008
	Screw, 3x6mm, Heat Sink Mtg.		R-Y013006		Screw, 3x6mm, PC Board Mtg.		R-Y013006
					Screw, 3mm, Bracket Mtg.		R-Y013000

RADIO SHACK  **A TANDY CORPORATION COMPANY**
U.S.A.: FORT WORTH, TEXAS 76107
CANADA: BARRIE, ONTARIO, CANADA L4M 4W5

TANDY CORPORATION

AUSTRALIA
 280-316 VICTORIA ROAD
 RYDALMERE, N S W. 2116

BELGIUM
 PARC INDUSTRIEL DE NANINNE
 5140 NANINNE

U. K.
 BILSTON ROAD
 WEDNESBURY, STAFFS WF10 7JN