

Sears

SIMPSON 260 METER

REPAIR PROGRAM

DIVISION 92

SOURCE 260

MAY, 1976

Courtesy of :
Simpson260.com

This booklet is designed as a simple trouble shooting guide to repair a Simpson 260 meter in your Service Center. All repairs are NOT covered, only the easy repairs that do not require major recalibration. If after following the enclosed procedure the problem has not been resolved, return the meter to the authorized repair source for your Territory.

A complete schematic and parts location list is included for your convenience for Model Series 3, 4, 5, 5P, 6, and 6P.

Repair parts are available from your Territorial Repair Parts Distribution Center. These parts are listed on ultrafiche in Division 92, Source 260.

SERVICE PROCEDURE - SIMPSON 260-3-4-5-5P-6-6P

THE FOLLOWING TESTS CAN BE PERFORMED TO DETERMINE DEFECTS AND DEFECTIVE COMPONENTS:

1. Set the instrument on the Rx1 range, short the test leads together and adjust the zero ohms for zero indication on the meter. If the pointer falls short of zero, **REPLACE THE 1.5 VOLT "D" SIZE BATTERY**. This should restore normal operation.
2. Next, set the 260 to the Rx10K range and adjust for zero ohms. If the pointer will not reach zero, change the four penlite batteries. (This applies to the 260-3 thru the series five.) In the 260-5P, change the 15 volt battery. In the 260-6 and 6P, this battery is a 9 volt transistor radio type (NEDA 1604).
3. If the pointer does not deflect in Steps 1 and 2, remove the test leads from their jacks and short the "common" and "plus" jacks together with a paper clip. The 260 should still be set on a resistance range while making this check. If the pointer moves, **REPLACE THE DEFECTIVE TEST LEADS**.
4. If the pointer did not deflect in Step 3 (260-3 thru 260-5P) remove the instrument case and check the internal fuse.

On the 260-6 and 6P, this fuse is accessible through the battery compartment.
5. If Steps 1 to 4 do not locate the trouble, or if the problem involves a single range only (such as Rx1 or 1 MA) then an odor or visual test should be made to locate a burned resistor. The location of the components are as shown on the drawings for the ranges most likely to cause difficulty.

NOTE

- 1: If a resistor burns out and causes the printed circuit board to become crystalized, the entire board must be

replaced because a degree of continuity is often set up across this area. This causes inaccuracies in the instrument and usually another breakdown in a short time.

NOTE

- 2: With the instrument out of the case be sure to check the switch decks for smoked areas or burn marks between contacts. If there is evidence of burn or arc marks, return unit to your authorized repair center.

NOTE

Switch replacement, COMPLETE calibration, meter movement replacement, or repair is considered a factory repair. Send the complete unit to your Authorized Repair Station.

OVERLOAD RELAY ADJUSTMENT (Model 260-5P and 260-6P)

NOTE

Field adjustments of the Overload Relay Leaf Switch causes intermittent or erratic operation of the unit. Replacement is recommended.

The mechanical adjustment of the relay is performed as follows;

- a. Refer to the drawing to locate the adjustment screw for the relay latching function. This can be adjusted with a small jeweler's screwdriver while the reset button is pushed in.
- b. With the reset button depressed, turn the screw out until it does not catch on the relay. No more than one or two turns should be required.
- c. Short the common and plus terminals and set the range and function switch on Rx100 and plus DC. This will provide an indication on the meter when the relay contacts are open or closed. Meter will read full scale when contacts are closed.

d. Now push the reset button and turn the screw clockwise until it just catches on the relay. This is to be done in small increments while allowing the button to spring in and out until it snaps into the hole.

e. The mechanism should be operated two or three times to be certain the latching and switch function is consistent. This can be accomplished by finger continuity between shunt R22 and the positive terminal of the 15 volt battery. Push in the reset button and then connect the two points together with the fingers.

This should cause the relay to release as indicated by the button "popping out".

NOTE

Finger contact at various points in the tester can cause the relay to release. Do not mistake accidental finger contact with the circuitry with a defective relay or its adjustment.

ANY REPAIR NOT COVERED IN THESE PROCEDURES IS CONSIDERED A FACTORY REPAIR.

TROUBLESHOOTING CHART, MODELS 260-3 THRU 260-6P

SYMPTOM	POSSIBLE DEFECT	CURE	NOTES
1. Rx1 will not zero with shorted input.	a. Defective "D" Battery b. Open resistor c. Defective range switch	a. Replace b. Replace	b. 260-3 thru 5P = R1,3,16,25. 260-6,6P = R16,17,19,21. c. See switch replacement
2. Rx10k will not zero with shorted input.	a. Defective battery b. Open resistor c. Defective range switch SW1	a. Replace b. Replace	a. 260-3 thru 260-5 B2 = 4 "AA" cells. 260-5P B2 - Eveready 417 or Equiv. 260-6,6P B2 = 9v NEDA 1604 b. 260-3 thru 5P = R4 260-6,6P - R18 c. See switch replacement
3. Rx100 will not zero with shorted input	a. Open resistor b. Defective switch SW-1	a. Replace	a. 260-3 thru 5P = R2 260-6,6P = R18 b. See switch replacement
4. 7.5 VAC range reads approx. 1/2 the actual voltage	a. Open diode D1 or D2	a. Replace	a. See calibration procedure
5. Out-of-tolerance indication at full scale on 2.5 VAC range	a. Calibration required b. D1 or D2 defective c. Defective calibration control d. Defective resistor	a. Recalibrate b. Replace c. Replace d. Replace	a. See calibration procedure c. 260-3 thru 5P = R28,31 260-6,6P = R22,25 d. 260-3 thru 5P = R26,29,30 260-6,6P = R23,24,26

TROUBLESHOOTING CHART, MODELS 260-3 THRU 260-6P

SYMPTOM	POSSIBLE DEFECT	CURE	NOTES
6. AC voltage range(s) defective	a. Defective resistors b. Defective range switch SW-1	a. Replace	a. 260-3 thru 5P = R6, 7, 9, 13 260-6,6P = R27 thru R30 b. See switch replacement.
7. DC current ranges defective	a. Open shunt resistor b. Defective range switch (SW-1)	a. Replace	a. 260-3 thru 5P = R5,17,18,19,22. 260-6,6P = R11 thru R15. b. See switch replacement.
8. DC voltage range(s) defective	a. Open multiplier resistors b. Defective range switch (SW-1)	a. Replace	a. 260-3 thru 5P = R8,10,12,14, and 15. 260-6,6P = R4 thru R8 b. See switch replacement.

CALIBRATION CHECK

DC VOLTAGE RANGES can be checked for accuracy by using a battery of proper voltage for the range being checked while monitoring the battery voltage being applied across the test leads with another 260 or equivalent meter.

RESISTANCE RANGES can be checked for accuracy by measuring a known value of resistance with the instrument.

AC VOLTAGE CALIBRATION

When the diodes or resistors in the bridge rectifier have been replaced, the 250 AC and 2.5 VAC ranges must be calibrated.

250 VAC RANGE CALIBRATION

Using the line voltage from an AC outlet as a calibrating voltage source and an accurate AC monitoring voltmeter, connect the test leads and adjust R31 (260-3 thru 260-5P) or R22 (260-6 and 6P) for the same reading as the monitoring voltmeter.

2.5 VAC RANGE CALIBRATION

Using an oscillator set to 1 volt RMS output at 60 hertz as read on a monitoring AC voltmeter. Set the 260 range switch to the 2.5 VAC range and connect the test leads to the monitored 1 VAC output of the oscillator. Adjust R28 (260-3 thru 260-5P) or R25 (260-6 and 6P) for the same reading as the monitoring voltmeter. This completes the AC calibration. SEE NOTE ON FOLLOWING PAGE.

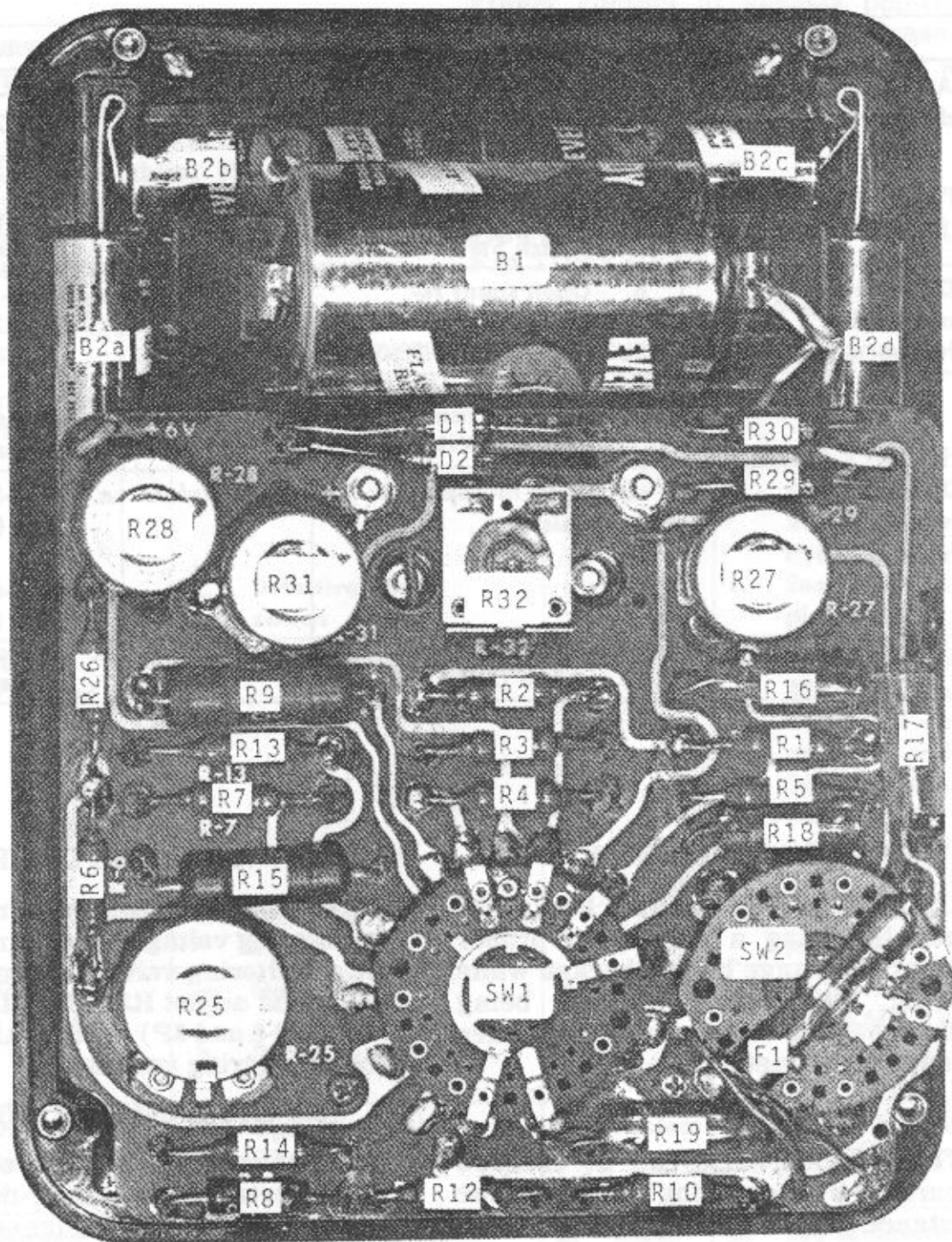

Simpson 260-3 & 4 Parts Location

NOTE: 260-3 DOES NOT USE R-32

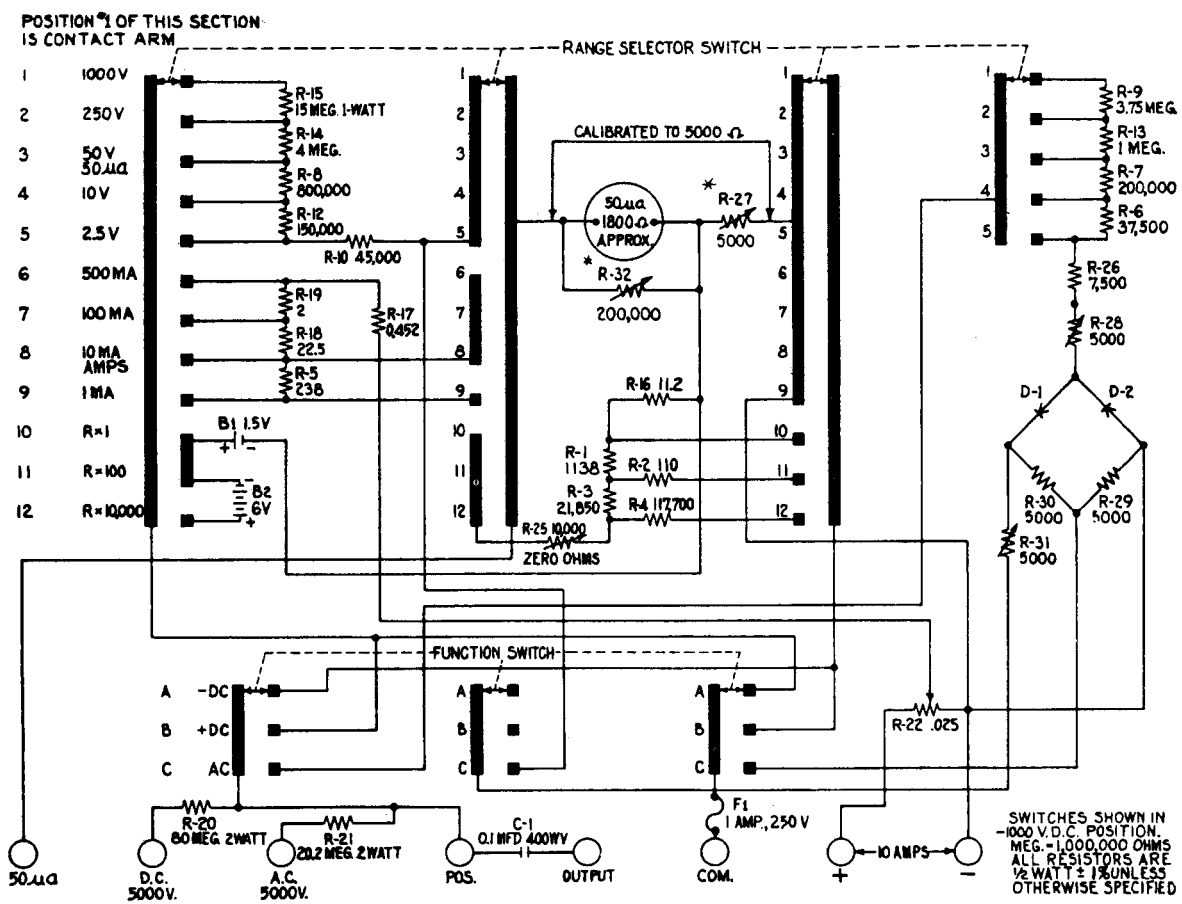

* R32 is adjusted for a circuit current of 50 microampers, then R27 is adjusted for a circuit resistance of 5,000 ohms.

OVERALL SCHEMATIC, SIMPSON VOLT-OHM-MILLIAMMETER 260 SERIES 4 & SERIES 4M

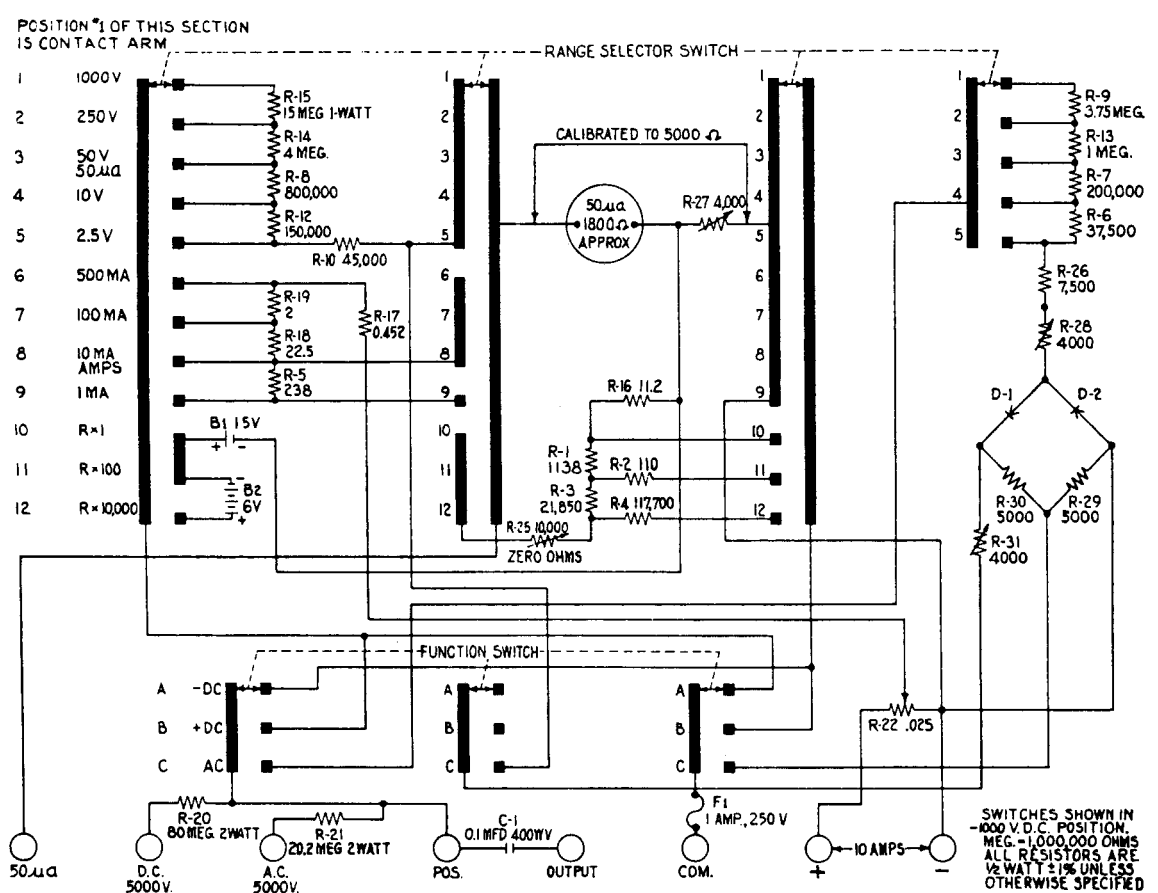

OVERALL SCHEMATIC, SIMPSON VOLT-OHM-MILLIAMMETER 260[®] SERIES III

D6 Thru R11
under overload
protection module

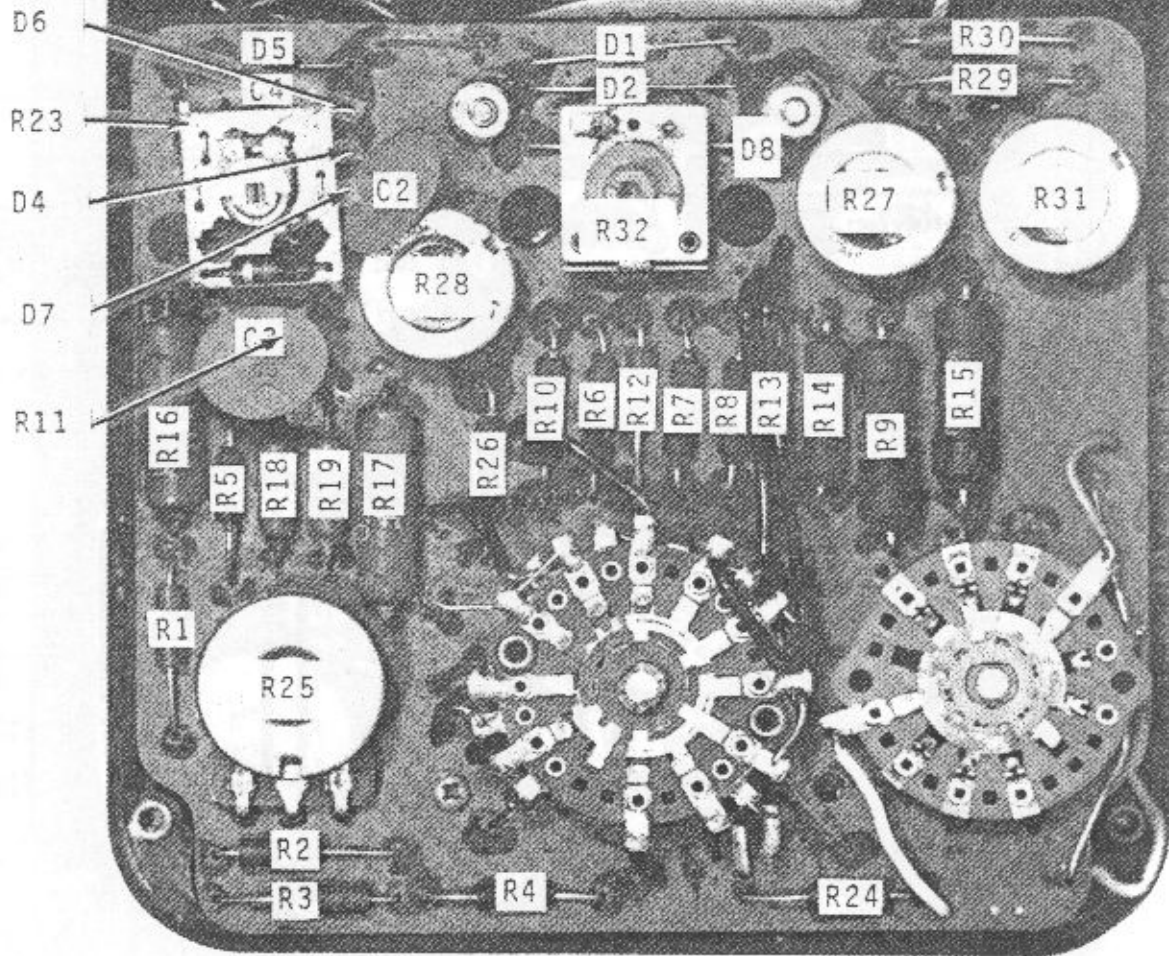

Simpson 260-5 & 5P Parts Location

NOTE: 260-5 DOES NOT HAVE
PROTECTION BOARD

POSITION OF THIS SECTION IS CONTACT ARM

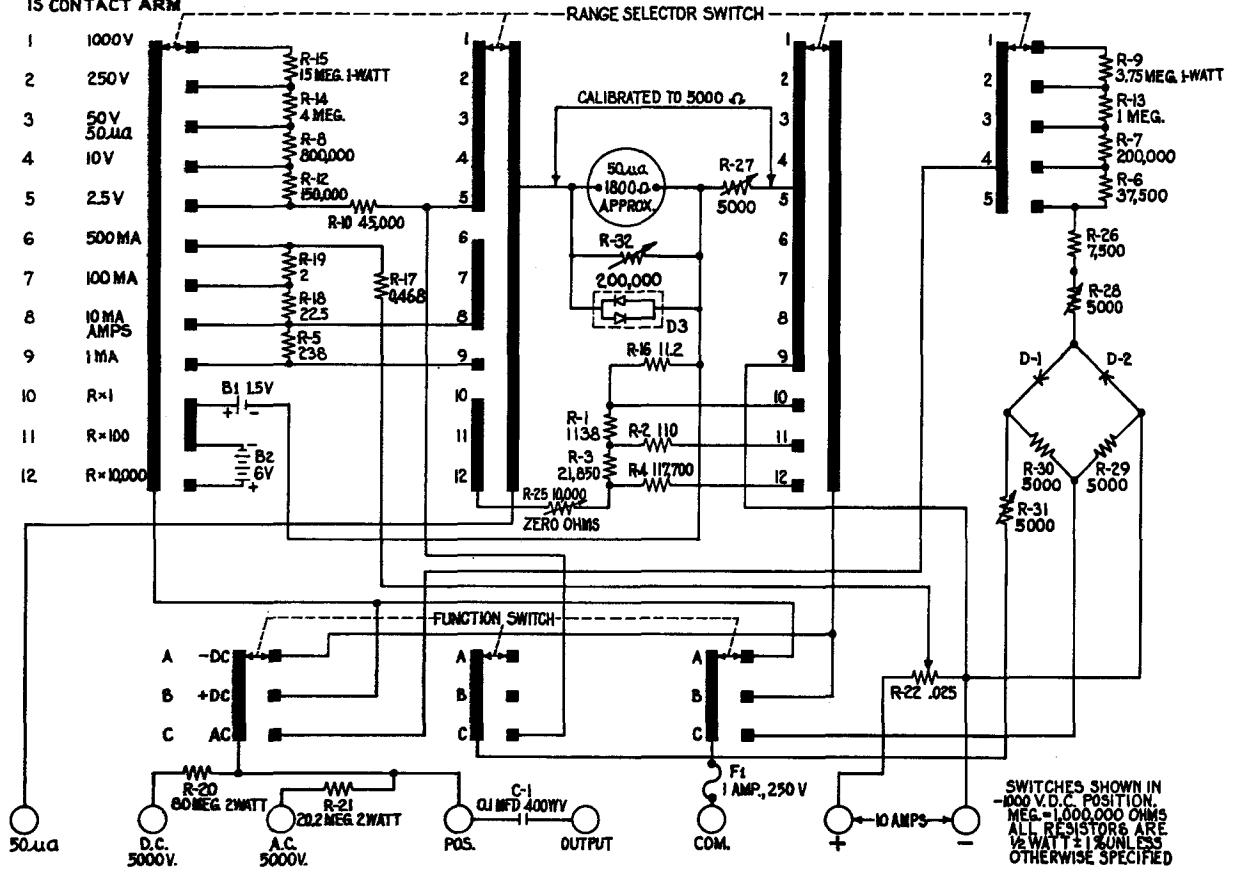

SCHMATIC DIAGRAM
MODEL 260-5

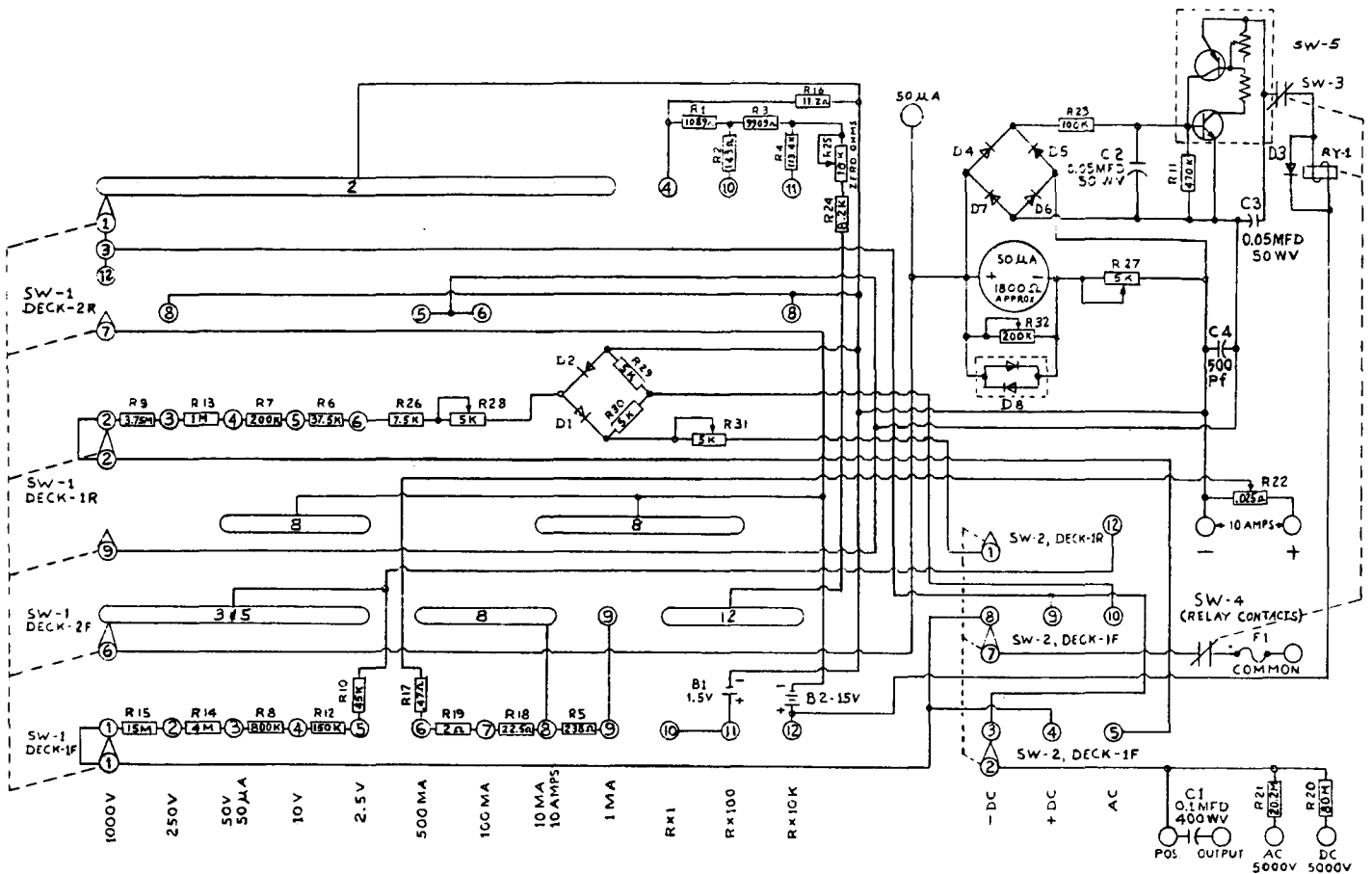

MODEL 260-5P - SCHEMATIC

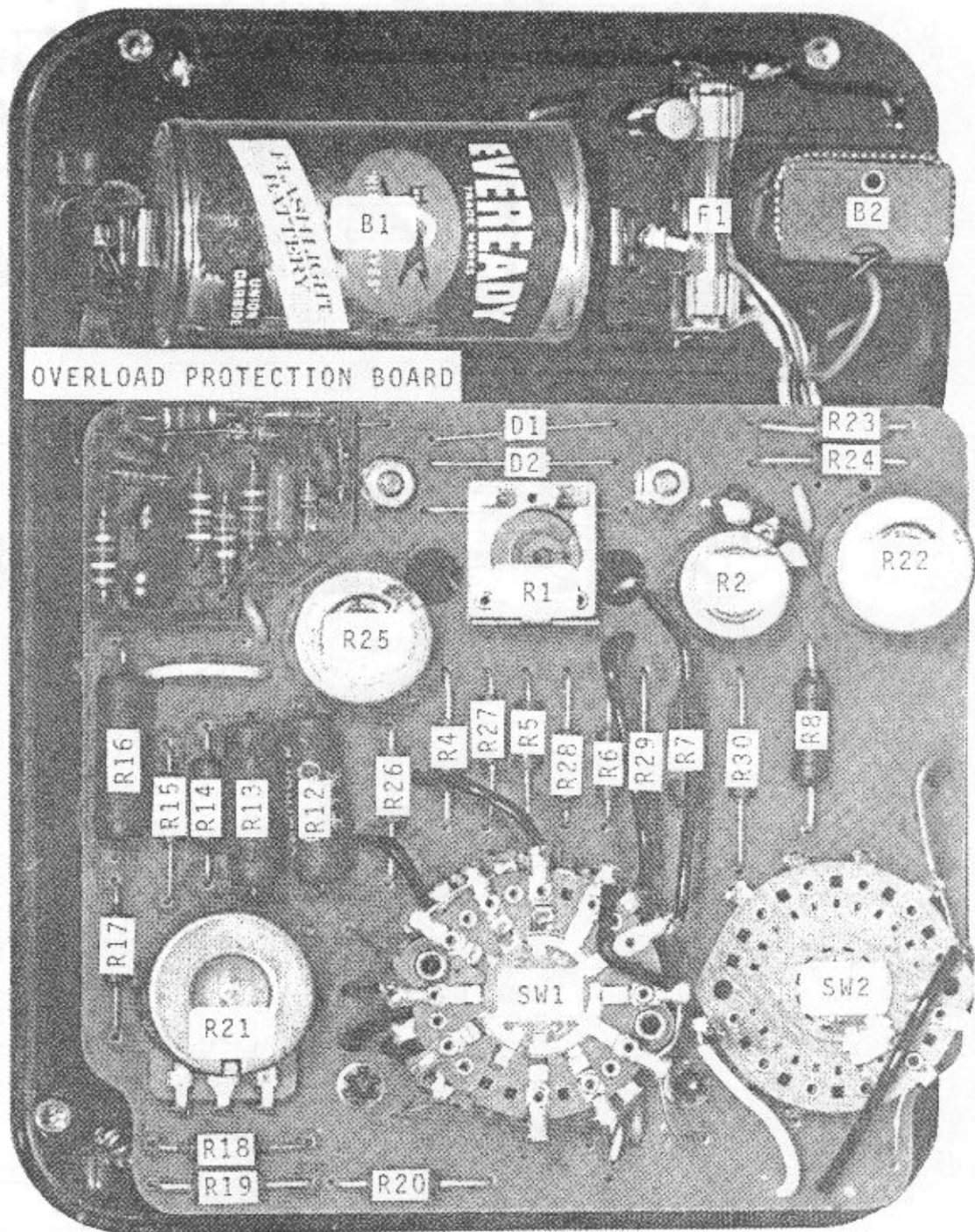

Simpson 260-6 & 6P Parts Location

**NOTE: 260-6 DOES NOT HAVE
PROTECTION BOARD**

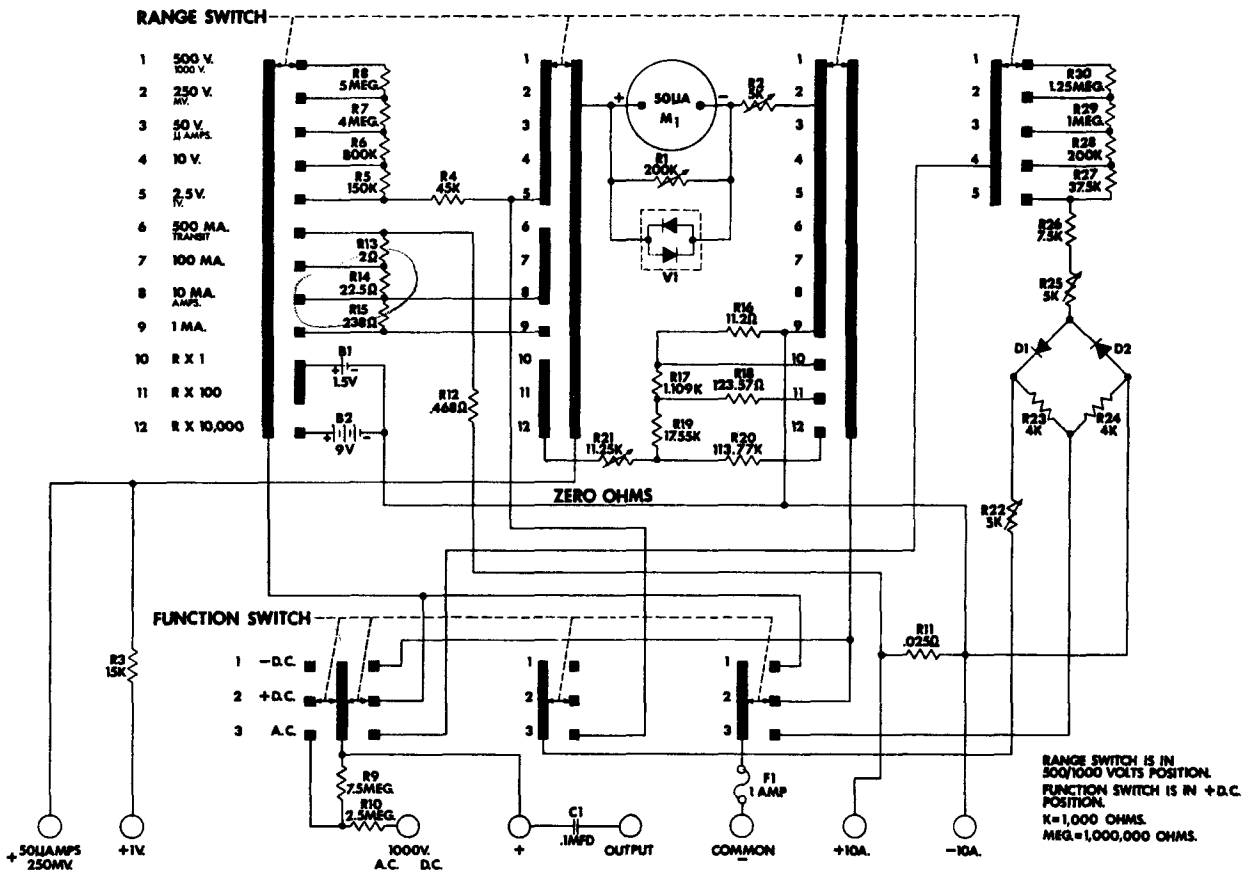

SCHEMATIC DIAGRAM
MODEL 260-6

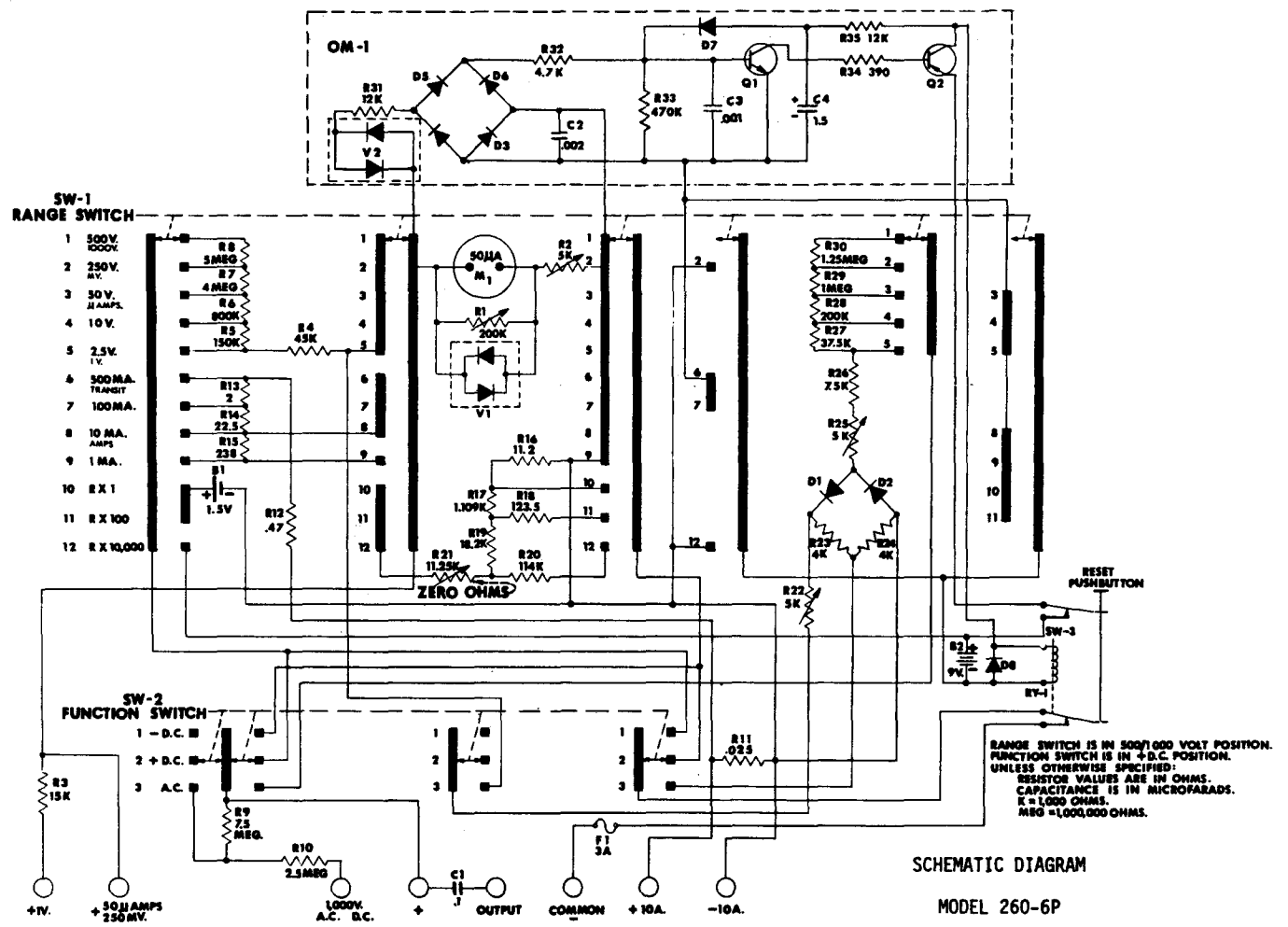

SCHEMATIC DIAGRAM
MODEL 260-6P