



MULTI-VEND OPERATING INSTRUCTIONS

(ENGLISH)

For additional help or information,
call toll free: 1-800-833-4411

READ & FOLLOW
STEP-BY-STEP INSTRUCTIONS

CAUTION:

Do not place machine under direct sunlight, excessive heat will melt candy products, which will affect the performance of the vending machine.

THE CENTER COMPARTMENT IS FACTORY SET FOR 1" GUMBALLS OR 1" CAPSULES. THE SIDE COMPARTMENTS ARE SET FOR CANDY.

A. HOW TO ASSEMBLE THE PIPE STAND

- A1. Place the **THREADED PIPE** into the **PEDESTAL BASE**. Turn **THREADED PIPE** clockwise until tightened.
- A2. Place **MULTI-VEND** onto **THREADED PIPE**. Rotate **MULTI-VEND** clockwise until tightened.

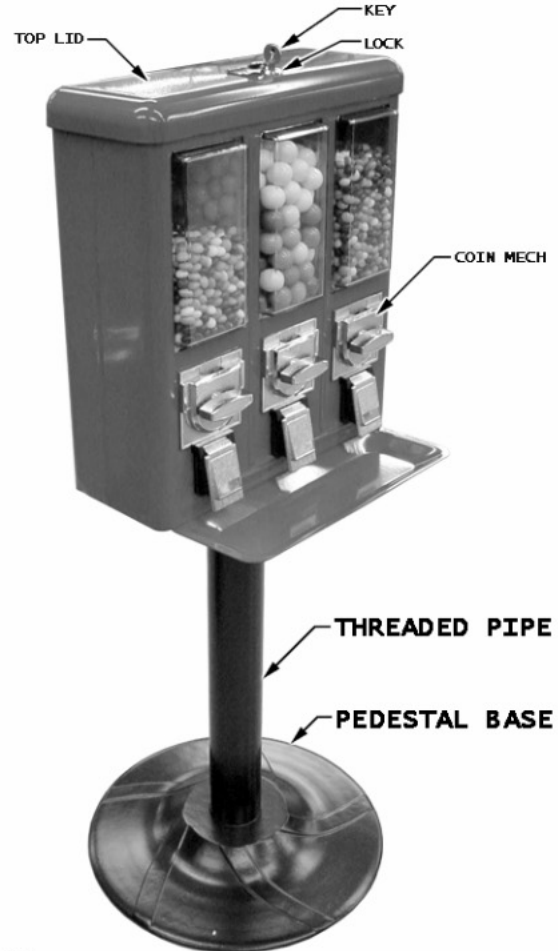

A1164E

B. HOW TO LOAD PRODUCTS

THE CENTER COMPARTMENT IS FACTORY SET FOR 1" GUMBALLS OR 1" CAPSULES. THE SIDE COMPARTMENTS ARE SET FOR CANDY.

B1. Use key to unlock and open the **TOP LID**.

B2. Partially fill each **COMPARTMENT** with product. The center compartment is set for gumballs while the side compartments are set for small size candy.

B3. Insert coin in each **COIN MECH** and perform several test vends on each **COMPARTMENT**.

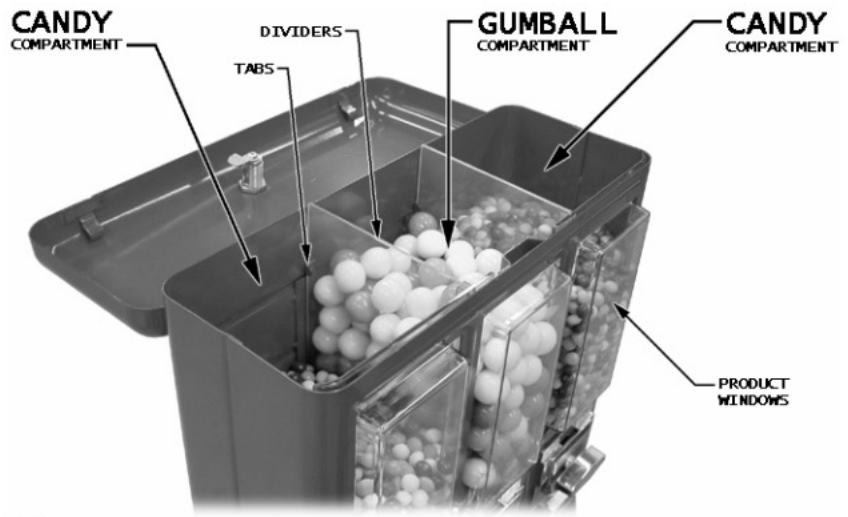

B4. If the candy compartment does not vend the desired quantity, refer to: **D. HOW TO ADJUST THE CANDY WHEEL**.

If the gumball compartment does not vend the desired quantity, refer to:

E. HOW TO ADJUST THE GUMBALL WHEEL.

B5. If machine vends the desired quantity, then continue filling the **COMPARTMENTS** with products.

B6. Close and lock the **TOP LID**.

C. HOW TO COLLECT COINS

C1. Use the **DOOR KEY** to unlock and open the **REAR ACCESS DOOR**.

C2. Remove coins from each of the **COIN TRAYS**.

C3. Close and lock the **COIN ACCESS DOOR**.



D. HOW TO ADJUST THE CANDY WHEEL

- D1.** Remove any products remaining in the **CANDY COMPARTMENT**.
- D2.** Use a small Phillips screwdriver to remove and save the three (3) screws holding the **CANDY BRUSH OFF PLATE**.
- D3.** Remove the **CANDY BRUSH OFF PLATE** and **CANDY WHEEL**.
- D4.** Lift the **ADJUSTER PLATE** and reposition the **TAB** to the desired **WHEEL SETTING NOTCH**. Notch #1 (counter-clockwise) is for the largest vends and notch #6 (clockwise) is for the smallest vends. The **ADJUSTER PLATE** can be completely removed if vending large products.

Example:

Approximately 20 pieces of Skittles, M&M's or peanuts if set at largest opening. Approximately 10 pieces at smallest opening.

- D5.** Install the **CANDY WHEEL** so that the **PORTION HOLE** is aligned (centered) over the **BASE HOLE**.

IMPORTANT:

An empty **PORTION HOLE** of the **CANDY WHEEL** must be aligned over the **BASE HOLE** in order for the **COIN MECHANISM** and **CANDY WHEEL** to work properly.

- D6.** Re-install the **CANDY BRUSH OFF PLATE** so that the springs are closest to the front of the machine. Secure with the three (3) screws saved from step D2.
- D7.** Partially fill the **COMPARTMENT** with product and perform a several test vends.
- D8.** If machine does not vend the desired quantity then go back to step D1. If machine vends correctly then continue to fill the **COMPARTMENT** with product.

- D9.** Close and lock the **TOP LID**.

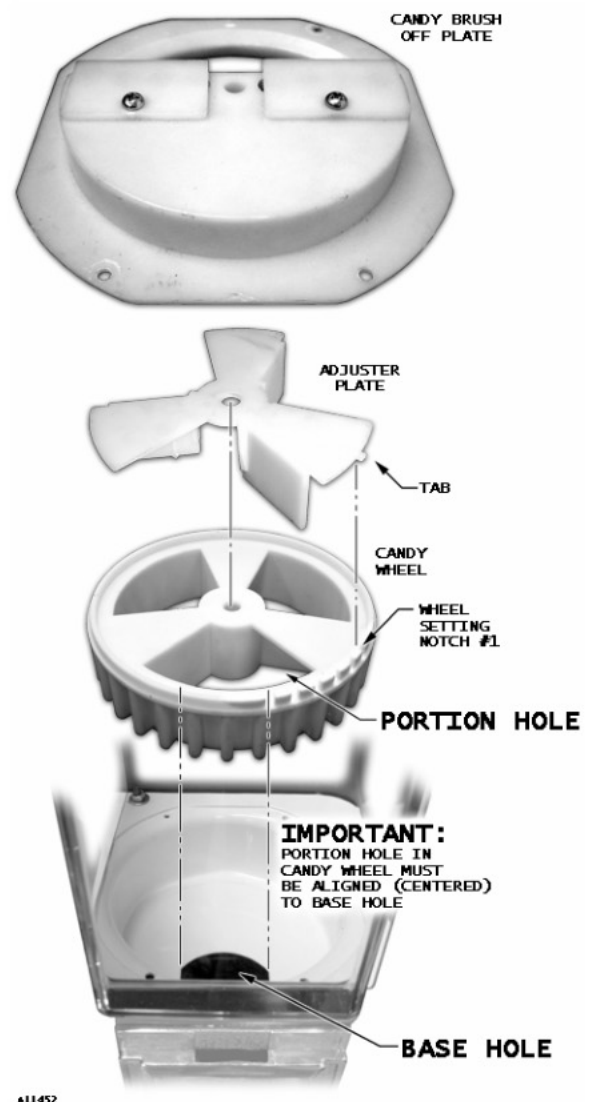
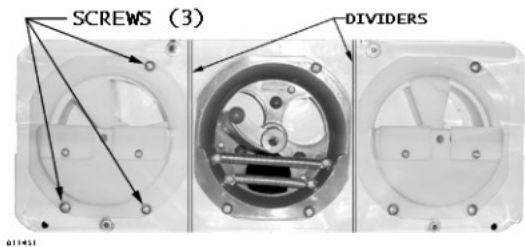

E. HOW TO ADJUST THE GUMBALL WHEEL

E1. Remove any products remaining in the **COMPARTMENT**.

E2. Use a small Phillips screwdriver to remove the three (3) screws holding down the **BRUSH OFF PLATE**.

E3. Remove the **BRUSH OFF PLATE** and **GUMBALL WHEEL**.

E4. Loosen the three **ADJUSTMENT SCREWS** on top of the **GUMBALL WHEEL** located next to each gumball cavity.

E5. Turn the **ADJUSTMENT WHEEL** to adjust the opening according to the product being vended. Maximum product size is a 1" gumball (850 count) or a 1" capsule.

E6. Tighten the **ADJUSTMENT SCREWS** on the **ADJUSTMENT WHEEL**.

E7. Install the **GUMBALL WHEEL** with one of the empty compartment holes aligned (centered) over the hole in the base.

E8. Install the **GUMBALL BRUSH OFF PLATE** so that the screw heads are showing on top and the two long springs are closest to the front of the vendor. Secure using the three (3) screws saved from step E2.

IMPORTANT :

An empty **PORTION HOLE** of the **GUMBALL WHEEL** must be aligned over the **BASE HOLE** for the **COIN MECHANISM** and **GUMBALL WHEEL** to work properly.

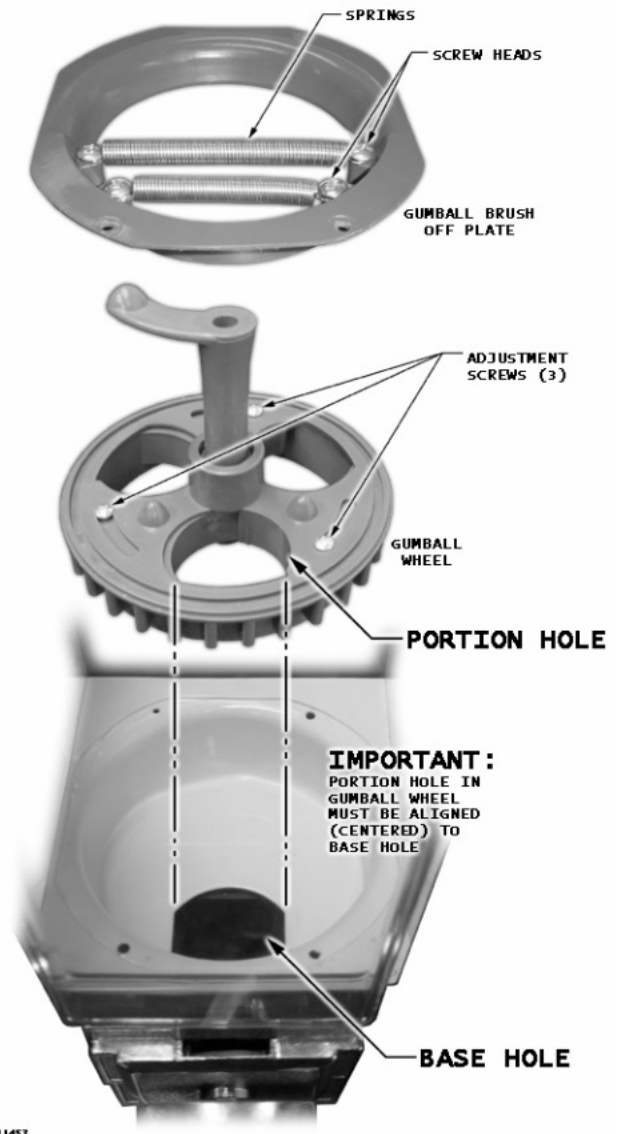
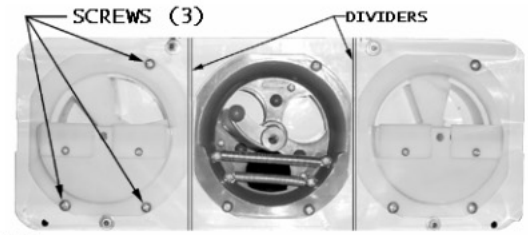

E9. Partially fill the **COMPARTMENT** with product and perform a several test vends.

E10. If machine does not vend the desired quantity then go back to step E1. If machine vends correctly then continue to fill the **COMPARTMENT** with product.

E11. Close and lock the **TOP LID**.