

Zeta quick Reference guide

Failure reset

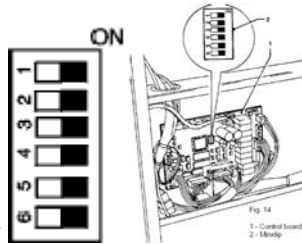

- Open the door
- Switch dip switch 6 on and close the door, wait for motors to reset
- Open door and switch dip 6 to off position, close door.

Loading

- Open the retaining gate by sliding inside the guides to the left.
- Load cans and bottles separately and ensure that the top layer is complete for each column.

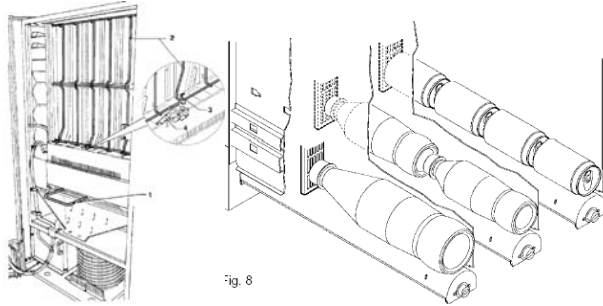

Audit

- **For audit of total machine sales, proceed as follows**

Open the door and set dipswitch 4 to the on position

Insert the override key into the door switch

View total sales in the display, remove the key and set dip 4 to off position.

- **For audit of separate selections, proceed as follows**

Open the door and set dip switch 2 to the on position

Insert the override key into the door switch

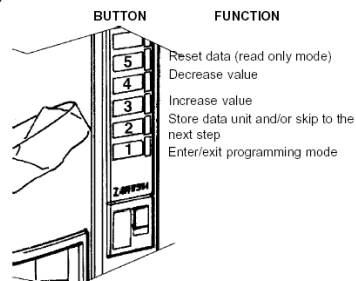

Press lower selection button once, view total for that selection

Press next button up, view total for that selection

Press again, the second button up to view the other selections, the selection that is viewed is also illuminated.

Audit reset

- Press the 5th button from the bottom to reset data
- Remove key and reset dip 2 to the off position, close the door.

-
- **Price setting.** Open the door and set dipswitch 1 to the on position
Insert the override key into the door switch
Wait for the display to read “PRO”

SELECTION BUTTONS

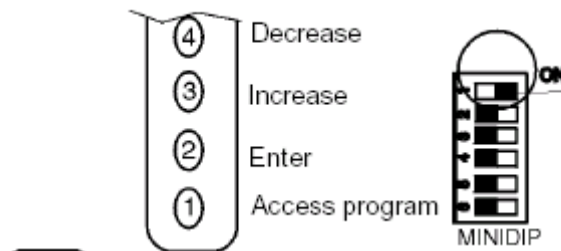

Press the lower selection button once, “Col 9” on display
Press next selection up, 4 times. Lower selection illuminates

The third button up will increase the price of this selection
The fourth button up will lower the price of this selection

To move to the next selection, press the second button up
The selection to be changed is illuminated.

-
- **Monthly cleaning**

Use only recommended cleaning products approved for foodstuff, preferably liquid; do not use powder and abrasive products that could scratch plastic surfaces.

Clean the outside surfaces of the machine and wipe off any residue

Open the door and disconnect the machine from the power supply.

Clean Galvanised parts and anti friction elements in lukewarm soapy water, ensure surfaces are rinsed and thoroughly dry, following cleaning.

Clean the dust from the refrigerator grills and left hand condenser assembly.

Carry out any operations regarding the payment system referring to the manufacturers guidelines

Clean the rear grille with a brush and Vacuum clean any dust.