

Brio 250

ESPRESSO

INSTANT

UK English



DOC. NO. H 150U 00
EDITION 1 01 01



Telefono +39 035 606111
Fax +39 035 606460
Trib. Bergamo Reg. Imp. n. 2534
R.E.A. Bergamo n. 319295

Cap. Soc. L. 29.064.000.000 i. v.
Cod. Fisc. 12806340159
Part. IVA 02747810162
Cod. ISO IT 02747810162

DICHIARAZIONE DI CONFORMITA'
DECLARATION OF CONFORMITY
DÉCLARATION DE CONFORMITÉ
KONFORMITÄTSEKTLÄRUNG
DECLARACIÓN DE CONFORMIDAD
DECLARAÇÃO DE CONFORMIDADE
VERKLARING VAN OVEREENSTEMMING
INTYG OM ÖVERENSSTÄMMESE
OVERENSSTEMMESESERKLÆRING

Valbrembo, 04/09/2000

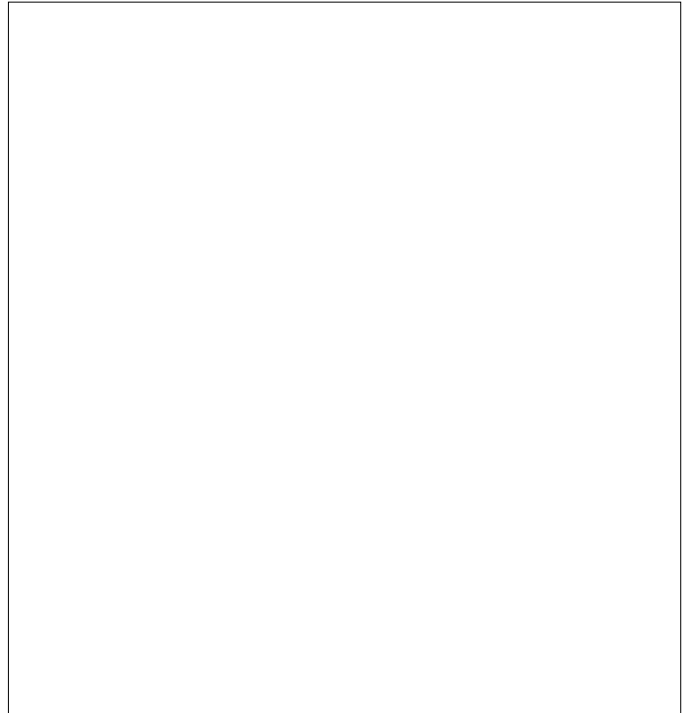

Dichiara che la macchina descritta nella targhetta di identificazione, è conforme alle disposizioni legislative delle direttive: **89/392, 89/336, 73/23 CEE** e successive modifiche ed integrazioni.

Declares that the machine described in the identification plate conforms to the legislative directions of the directives: **89/392, 89/336, 73/23 EEC** and further amendments and integrations.

Déclare que l'appareil décrit dans la plaque signalétique satisfait aux prescriptions des directives: **89/392, 89/336, 73/23 CEE** et modifications/intégrations suivantes.

Erklärt, daß das im Typenschild beschriebene Gerät den **EWG** Richtlinien **89/392, 89/336, 73/23** sowie den folgenden Änderungen/Ergänzungen entspricht.

Declara que la máquina descrita en la placa de identificación, resulta conforme a las disposiciones legislativas de las directivas: **89/392, 89/336, 73/23 CEE** y modificaciones y integraciones sucesivas.

Declara que o distribuidor descrita na chapa de identificação é conforme às disposições legislativas das directivas **CEE 89/392, 89/336 e 73/23** e sucessivas modificações e integrações.

Verklaart dat de op de identificatieplaat beschreven machine overeenstemt met de bepalingen van de **EEG** richtlijnen **89/392, 89/336** en **73/23** en de daaropvolgende wijzigingen en aanvullingen.

Intygat att maskinen som beskrivs på identifieringsskylten överensstämmer med lagstiftningsföreskrifterna i direktiven: **89/392, 89/336, 73/23 CEE** och påföljande och kompletteringar.

Det erklæres herved, at automaten angivet på typeskiltet er i overensstemmelse med ovsdirektiverne **89/392, 89/336** og **73/23 CEE** og de senere ændringer og tillæg.



ANTONIO CAVO

C.E.O



THE INTERNATIONAL CERTIFICATION NETWORK

CERTIFICATE

**IQNet and
CISQ/IMO-CSQ**

hereby certify that the organization

NECTA VENDING SOLUTIONS S.p.A.
Via Roma, 24 - I-24030 VALBREMBO (BG)

for the following field of activities
Design, manufacturing and sale of
electromechanical/electronic vending machines
has implemented and maintains a
Quality Management System
which fulfills the requirements of the following standard

ISO 9001

Issued on: 2000 - 03 - 31

Registration Number: **IT - 12979**



Catherine Neville
Catherine Neville
President of IQNet



Gianrenzo Prati
Gianrenzo Prati
President of CISQ

Members of IQNet (registered associations):

- AENOR Spain AFAQ France AIB-Vinçotte International AR CER Portugal CISQ Italy
- COQ Czech Republic DQS Germany DS Denmark ELOT Greece FCAV Brazil HKQAA Hong Kong
- ICONTEC Colombia IRAM Argentina JQA Japan KEMA Netherlands KSA-QA Korea MSZT Hungary NCS Norway
- NSAI Ireland OQS Austria PCB Poland PSB Singapore QAS Australia QMI Canada SFS Finland
- SII Israel SIQ Slovenia SQS Switzerland

IQNet is represented in the USA by the following IQNet members: AFAQ, AIB-Vinçotte International, CISQ, DQS, KEMA, NSAI and QMI

Federazione - Federation

CISQ

a member of IQNet

CISQ is an independent
Federation of independent
organisations of the Sector of
Quality Control, operating in the
Sector of Quality Control.

CISQ is a multi-sector, independent,
non-profit Federation of Italian
organisations for the certification
of company management systems,
each operating in its own sector
of responsibility.

CERTIFICAZIONE ITALIANA DEI SISTEMI QUALITÀ AZIENDALI
ITALIAN CERTIFICATION OF COMPANY QUALITY SYSTEMS

CERTIFICATO n. _____
CERTIFICATE n. **9130.ZAVE**

SI CERTIFICA CHE IL SISTEMA QUALITÀ DI
NE HEREBY CERTIFY THAT THE QUALITY SYSTEM OPERATED BY

NECTA VENDING SOLUTIONS S.p.A.

UNITÀ OPERATIVE
OPERATIVE UNITS

Via Roma, 24 - 24030 VALBREMBO (BG)

UNI EN ISO 9001

È CONFORME ALLA NORMA
IS IN COMPLIANCE WITH THE STANDARD

PER LE SEGUENTI ATTIVITÀ
CONCERNING THE FOLLOWING ACTIVITIES

Progettazione, produzione e commercializzazione di
apparecchiature elettromeccaniche/elettroniche per la
distribuzione automatica e la ristorazione
Design, manufacturing and sale of
electromechanical/electronic vending machines

IL PRESENTE CERTIFICATO È SOGGETTO AL RISPETTO DEL REGOLAMENTO
PER LA CERTIFICAZIONE DEI SISTEMI QUALITÀ DELLE AZIENDE
THE USE AND THE VALIDITY OF THE CERTIFICATE SHALL SATISFY THE REQUIREMENTS
OF THE RULES FOR THE CERTIFICATION OF COMPANY QUALITY SYSTEMS

1 Giugno 1994

Prima emissione
First issue

31 Marzo 2000

Emissione corrente
Current issue

La validità del presente certificato è subordinata a sorveglianza annuale e al riesame completo del Sistema di
Qualità con periodicità triennale secondo le procedure dell'IMO S.p.A.
The validity of the certificate is submitted to annual audits and a reassessment of the entire Quality System
within three years according to IMO S.p.A. rules

SINCERT
SISTEMI QUALITÀ

EA: 19

0001 4701 - 024 390

TABLE OF CONTENTS

INTRODUCTION	PAGE 2	OPERATING MODES	PAGE 14
IDENTIFICATION OF THE VENDING MACHINE	PAGE 2	NORMAL OPERATING MODE	PAGE 14
IN CASE OF FAILURE	PAGE 2	MAINTENANCE MODE	PAGE 14
TRANSPORT AND STORAGE	PAGE 2	PROGRAMMING	PAGE 15
USING THE VENDING MACHINE	PAGE 3	DISPLAYING PRESENT FAILURES	PAGE 16
POSITIONING THE VENDING MACHINE	PAGE 3	SETTING THE WATER AND POWDER DOSES	PAGE 17
WARNING FOR INSTALLATION	PAGE 3	SETTING THE PRICES	PAGE 17
PRECAUTIONS IN USING THE MACHINE	PAGE 3	SETTING THE PRICES AND THE SELECTION STATUS	PAGE 17
WARNING FOR SCRAPPING	PAGE 3	SETTING THE BASIC UNIT AND THE DECIMAL POINT	PAGE 17
TECHNICAL SPECIFICATIONS	PAGE 3	PROGRAMMING THE VALIDATOR LINES	PAGE 17
POWER CONSUMPTION	PAGE 4	INITIALISING	PAGE 17
ACCESSORIES	PAGE 4	SETTING THE MACHINE CODE	PAGE 18
LOADING AND CLEANING	PAGE 5	MACHINE CONFIGURATION	PAGE 18
DOOR SWITCH	PAGE 5	SELECTION COUNTER	PAGE 18
MAINTENANCE AND DISINFECTION	PAGE 5	INSTALLATION	PAGE 18
CONTROLS AND INFORMATION	PAGE 5	RESETTING FAILURES	PAGE 18
LOADING CUPS	PAGE 6	DISPLAYING THE STATISTICS	PAGE 18
LOADING COFFEE	PAGE 6	PRINTING THE STATISTICS	PAGE 18
LOADING SUGAR AND INSTANT PRODUCTS	PAGE 6	RESETTING THE STATISTICS	PAGE 18
LOADING STIRRERS	PAGE 6	PROGRAMMER	PAGE 19
FILLING WITH WATER	PAGE 6	AUTOMATIC SETUP TRANSFER	PAGE 19
SANITISING THE MIXERS AND FOODSTUFF CIRCUITS	PAGE 6	TRANSFERRED DATA	PAGE 19
CLEANING THE WATER SUPPLY TANK	PAGE 7	SETTING THE LANGUAGE	PAGE 19
CLEANING THE WASTE TRAY	PAGE 7	MAINTENANCE	PAGE 20
CLEANING THE CUP SHIFTING ARM	PAGE 7	INTRODUCTION	PAGE 20
CLEANING THE SUGAR RELEASE DEVICE	PAGE 8	BREWING UNIT MAINTENANCE	PAGE 20
WEEKLY CLEANING OF COFFEE UNIT	PAGE 8	ANNUAL SANITISING	PAGE 21
SUSPENDING FROM USE	PAGE 8	PRINTED BOARD FUNCTIONS AND INDICATOR LIGHTS	PAGE 22
INSTALLATION	PAGE 9	CONTROL BOARD	PAGE 22
UNPACKING THE VENDING MACHINE	PAGE 9	PUSH-BUTTON BOARD	PAGE 22
INSERTING THE LABELS	PAGE 9	CONFIGURING THE CONTROL BOARD	PAGE 22
CONNECTING TO THE WATER MAINS	PAGE 9	CONFIGURING THE MODEL	PAGE 23
CONNECTING TO THE POWER SUPPLY	PAGE 10	CONFIGURING THE STIRRER DISPENSER	PAGE 23
DOOR SWITCH	PAGE 10	CONFIGURING THE PAYMENT SYSTEM	PAGE 23
INSTALLING THE PAYMENT SYSTEM	PAGE 10	HYDRAULIC SYSTEMS	PAGE 24
WATER SOFTENER UNIT	PAGE 10		
FILLING THE WATER SYSTEM	PAGE 10		
OPERATION OF THE COFFEE UNIT	PAGE 11		
COFFEE DISPENSING CYCLE	PAGE 11		
CHECKING AND ADJUSTING THE MACHINE SETTINGS	PAGE 11		
STANDARD SETTINGS	PAGE 11		
ADJUSTING THE COFFEE UNIT PISTON STROKE SETTING	PAGE 12		
WATER TEMPERATURE CONTROL	PAGE 12		
ADJUSTING THE GRADE OF GRINDING	PAGE 12		
ADJUSTING THE COFFEE DOSE	PAGE 13		
CUP SENSOR	PAGE 13		

INTRODUCTION

This technical documentation is part and parcel of the vending machine and must always follow the machine in case it is moved or ownership is transferred, so as to permit consultation by different operators.

Before installing and using the machine, it is first necessary to carefully read and understand the instructions contained in this manual, as they offer important hints on safe installation, use and maintenance.

This manual is divided into three sections.

The **first section** describes the loading and routine cleaning operations which are carried out in areas of the machine accessible with the simple use of the door key, without any other tools.

The **second section** contains the instructions for correct installation and all information necessary for optimum use of the machine.

The **third section** describes maintenance operations which involve the use of tools to access potentially dangerous areas.

The operations described in the second and third sections must be carried out only by personnel who have the specific knowledge of the machine functioning from a point of view of electrical safety and health regulations.

The vending machines in the Brio range are designed to meet a wide spectrum of user needs.

This manual describes all possible machine configurations and the related safety and maintenance instructions.

Nonstandard devices will be indicated as "optional".

IDENTIFICATION OF THE VENDING MACHINE AND ITS CHARACTERISTICS

Every machine is identified by its own serial number, indicated on the data plate attached inside the cabinet on the right-hand side.

This plate (see Figure) is the only one acknowledged by the manufacturer and indicates all of the data which readily and safely gives technical information supplied by the manufacturer. It also assists in spare parts management.

IN CASE OF FAILURE

In most cases, any technical problems are corrected by small repair operations; however, before contacting the manufacturer we recommend that this manual be read carefully.

Should there be serious failures or malfunctions, then contact the following:

NECTA
VENDING SOLUTIONS SpA
Via Roma 24
24030 Valbrembo
Italy - Tel. +39 - 035606111

TRANSPORT AND STORAGE

To prevent any damage, special care should be taken when loading or unloading the vending machine.

The machine can be lifted by a motor-driven or manual fork lift truck, and the blades are to be placed underneath the machine from the side which is clearly indicated by the symbol on the packing.

Do not:

- overturn the vending machine;
- drag the vending machine with ropes or similar;
- lift the vending machine by its sides;
- lift the vending machine with slings or ropes;
- shake or jolt the vending machine and its packing.

The machine should be stored in a dry room where the temperature remains between 0° C and 40° C.

It is important not to stack more machines and always maintain the vertical position as indicated by the arrows on the packing.

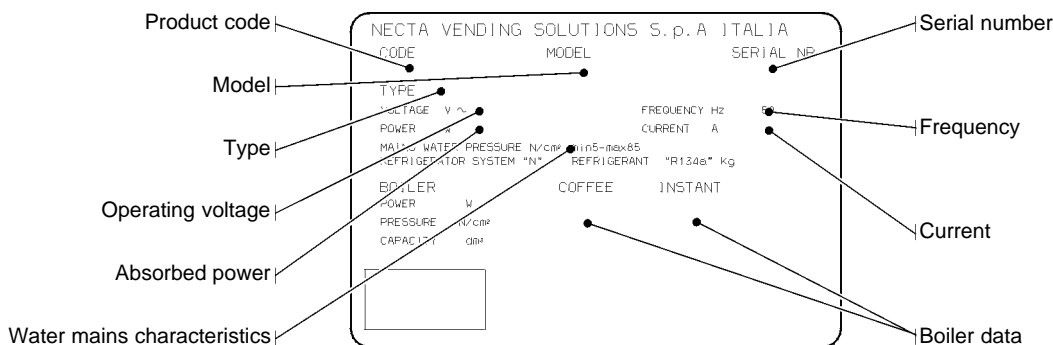

USING THE VENDING MACHINES OF HOT DRINKS IN OPEN CONTAINERS

(Ex.: plastic cups, ceramic cups, jugs)

The vending machines of drinks in open containers should be used only to sell and dispense drinks obtained by:

- brewing products like coffee and tea;
- reconstituting instant and lyophilized products;

These products should be declared by the manufacturer as "suitable for automatic vending" in open containers.

The dispensed products should be consumed immediately. Under no circumstances should they be preserved and/or packed for later consumption.

Any other use is unsuitable and thus potentially dangerous.

POSITIONING THE VENDING MACHINE

The vending machine is not suitable for outdoor installation. It must be installed in a dry room where the temperature is between 2° C and 32° C, and not where water jets are used for cleaning (e.g. in large kitchens, etc.).

The machine should be placed close to a wall, so that the back panel is at a minimum distance of 4 cm from it and correct ventilation may be ensured.

The machine must never be covered with cloth or the like. The machine should be positioned with a maximum inclination of 2°.

If necessary provide proper levelling by way of the adjustable feet included.

Important notice!!

Access to the machine interior for maintenance and/or repairs is via the back panel.

Therefore, provisions should be made for the machine to be rotated, thus allowing removal of the back panel.

Positioning the machine on a cabinet

The machine can be installed on a table or on any other suitable stand (recommended height is 820 mm).

If possible, it is advisable to use the special cabinet, which can house the liquid waste tray, the water supply kit, the payment system and, in the case of very hard water, the softener unit.

WARNING FOR INSTALLATION

The machine installation and the following maintenance operations should be carried out by qualified personnel only, who are trained in the correct use of the machine according to the standards in force.

The machine is sold without payment system, therefore the installer of such system has sole responsibility for any damage to the machine or to things and persons caused by faulty installation.

The integrity of the vending machine and its conformity with the rules and regulations in force for its relevant systems must be checked by qualified personnel at least once a year.

PRECAUTIONS IN USING THE MACHINE

The following precautions will assist in protecting the environment:

- use biodegradable products only to clean the machine;
- adequately dispose of all containers of the products used for loading and cleaning the machine;
- switch the machine off during periods of inactivity, thus achieving considerable energy savings.

WARNING FOR SCRAPPING

Whenever the machine is to be scrapped, the laws in force regarding environment protection should be strictly observed. More specifically:

- ferrous and plastic materials and the like are to be disposed of in authorized areas only;
- insulating materials should be recovered by qualified companies.

TECHNICAL SPECIFICATIONS

Height	750	mm
Width	540	mm
Depth	550	mm
Height of cabinet	820	mm

DIMENSIONS

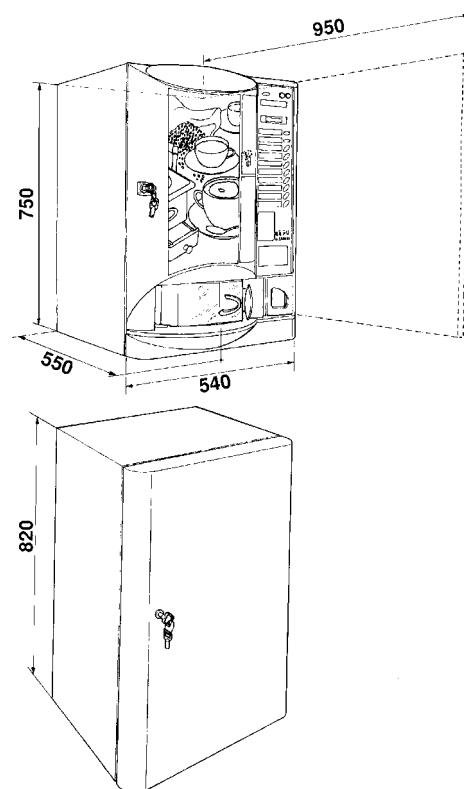

Power supply voltage	230	V~
Frequency	50	Hz
Installed power		
- Espresso	1.4	kW
- Instant	1.9	kW

Weight

- Espresso 55 Kg
- Instant 55 Kg

CUP DISPENSER

Suitable for cups with a rim diameter of 73-74 mm. with a capacity of approximately 250 cups;

COIN MECHANISM

The machine can be supplied with provisions for the installation of Executive payment systems.

SALES PRICES

A different programmable price can be set for each selection;

the standard setting has the same price for all selections.

JUG FACILITIES AND FREE VEND

Using a special key, up to 5 selections of fresh brew can be dispensed without cup to fill a jug, or to get free dispensing of normal selections.

COIN BOX

Made of plastic with lock as optional accessory.

WATER SUPPLY

From the mains, with a water pressure of 5 to 85 N/cm².

AVAILABLE ADJUSTMENTS

Espresso models: coffee dose, grinding, instant product and water doses by volume.

Instant models: time adjustment for instant product and water doses.

Temperature control

Factory set on the correct operating temperature. A trimmer located on the control board allows small adjustments (as necessary).

CONTROLS

- Presence of cups
- Presence of water
- Presence of coffee
- Presence of coffee unit
- Liquid waste container full (optional for models with water supply tank)
- Operating temperature reached

SAFETY DEVICES

- Door switch
- Presence of liquid waste container
- Manual-reset boiler safety thermostat
- Air-break float
- Overflow solenoid valve (only with water supply from the mains)
- Liquid waste container float
- Instant boiler anti-boiling thermostat (instant models)

- Time protection for:

Pump
Coffee unit ratiomotor
Coffee grinder

- Overheating protection for:

Doser units
Coffee unit ratiomotor
Magnets
Pump
Electric mixers
Coffee grinder motor

- Fuse protection for:

Electronic card power supply transformer
Executive power supply transformer

CAPACITY OF CONTAINERS

Coffee beans	1.8	Kg
Sugar	1.9	Kg
Powdered milk	0.8	Kg
Instant coffee	0.7	Kg
Tea	2.0	Kg
Chocolate	1.5	Kg
Stirrers (N.)	245	

POWER CONSUMPTION

The machine power consumption depends on many factors, such as the temperature and ventilation of the room where it is installed, the inlet water and boiler temperature, etc.

Under average conditions, and namely:

- ambient temperature:	22°	C
- boiler temperature:	93°	C
- inlet water temperature:	18°	C
- average water dose per selection:	93	cc
the following power consumption resulted:		
- to reach operating temperature	53	Wh
- for each hour of stand-by	110	Wh
- for each selection (average)	7.65	Wh

The above power consumption calculated from average data should only be taken as an indication.

ACCESSORIES

A wide range of accessories can be installed on the machine to change its performance:

The assembly kits are supplied with their own installation and test instructions, which must be strictly observed to ensure the machine's safety.

Installation and the following testing operations, must be carried out only by qualified personnel who have the specific knowledge of the machine functioning from a point of view of both electrical safety and health regulations.

LOADING AND CLEANING

DOOR SWITCH

When opening the door a special switch disconnects the power from the machine electrical system to allow the operations described below, regarding loading and routine cleaning, in full safety.

All operations requiring the machine to be energized should be carried out by qualified personnel ONLY, informed about the specific risks of such situation.

To energize the system with the door open, simply insert the special key into the slot (see Fig. 1).

The door can be closed only after removing the key.

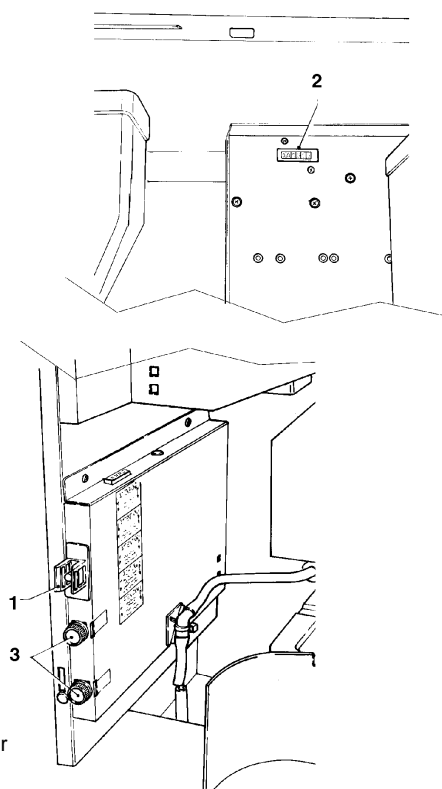

Fig. 1

- 1 - Door switch
- 2 - Mechanical counter
- 3 - Net fuses

MAINTENANCE AND DISINFECTION

According to current safety rules and health regulations, the operator of an automatic vending machine is responsible for the hygiene and the maintenance of the foodstuff circuits, to prevent formation of bacteria.

At installation the hydraulic circuits and the parts in contact with foodstuff should be fully sanitised to remove any bacteria which might have formed during storage.

It is advisable that specific sanitising agents (such as chlorine-based detergents or similar) are used for cleaning also the surfaces which are not directly in contact with foodstuff.

Some parts of the machine can be damaged by strong detergents.

The manufacturer declines all responsibility for any damage caused by the use of strong or toxic chemicals.

Before starting any maintenance operations requiring parts of the unit to be removed, the machine must always be disconnected from the power supply.

CONTROLS AND INFORMATION

All user controls and information are located on the external side of the door (see Fig. 2).

The labels with the selection menu and the instructions supplied with the machine must be inserted at the time of installation, referring to the selection dose table.

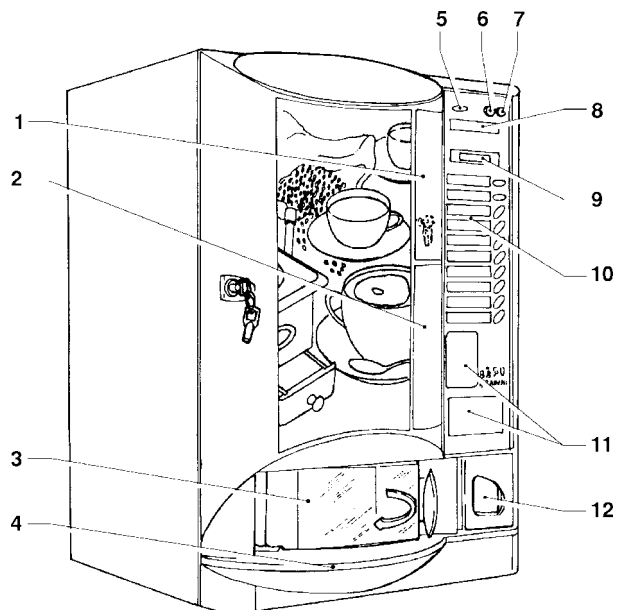

Fig. 2

- 1 - Prearrangement for payment systems
- 2 - Spaces for product labels
- 3 - Dispensing compartment
- 4 - Liquid waste tray
- 5 - Coin slot
- 6 - "Exact amount" warning light
- 7 - Coin return button
- 8 - Instruction labels
- 9 - Alphanumeric display
- 10 - Available selection menu
- 11 - Prearrangement for front validator and/or labels
- 12 - Coin return compartment

The Programming button, used to access the machine functions, is located on the internal side of the push-button board.

Press the Programming button twice to access "Programming" mode.

Press selection button No. 5 to automatically start filling the machine water system.

LOADING CUPS

In order to load the machine with cups do as follows:

- disconnect the electricity from the machine;
- release the cup container, by pushing the hook lever outwards, and tilt it forward;
- ensure that the column rotation knob has the lid locking notch lining up with the opening on the lid itself (if the dispenser is empty the positioning will be automatic);
- then, lift the knob and manually rotate the central stacker clockwise;
- lift the container lid;
- lower the cup container hatch;

Fig. 3

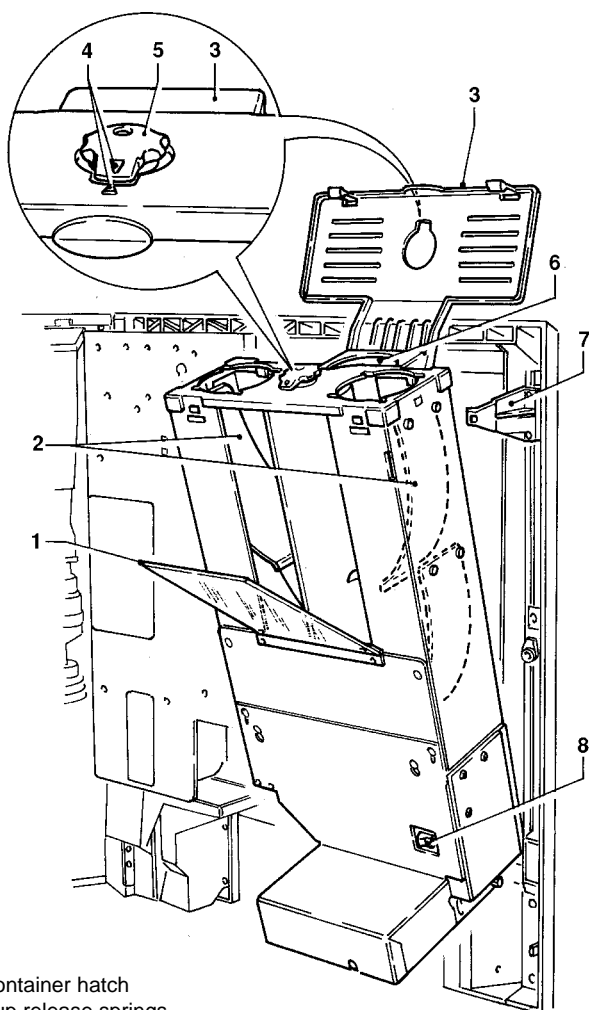

- 1 - Container hatch
- 2 - Cup release springs
- 3 - Container lid
- 4 - Lid locking notch.
- 5 - Column rotation knob
- 6 - Central stacker
- 7 - Container hook lever
- 8 - Cup release button

- fill the columns with cups ensuring that they are not forced inside each other;

- the central column must be filled last;

- close the machine and make a test selection.

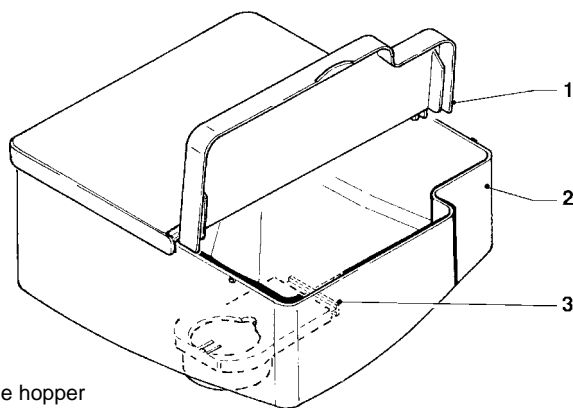

Fig. 4

- 1 - Lid
- 2 - Coffee hopper
- 3 - Shutter

LOADING COFFEE

Lift the lid and fill the hopper with coffee, ensuring that the shutter is fully open (see Fig. 4).

LOADING SUGAR AND INSTANT PRODUCTS

After lifting its cover, fill each container with the appropriate product, taking care not to compress it to prevent packing. Make sure the products do not contain any clots.

LOADING STIRRERS

Remove the stirrer weight and insert the stirrers to be loaded. Remove the paper strip, ensuring that the stirrers are all placed horizontally. Replace the stirrer weight.

The stirrers must be burr free and not curved.

FILLING WITH WATER (OPTIONAL)

For machine versions equipped with a tank inside the support cabinet (20 l) water must be filled manually as follows:

- sanitise the tank as indicated at the paragraph "Cleaning the water supply tank";
- fill the tank with drink water.

SANITISING THE MIXERS AND FOODSTUFF CIRCUITS

When installing the machine, and then at least once a week or even more frequently according to the use of the machine and the quality of the inlet water, the mixers and the instant drink dispensing conduits must be thoroughly disinfected, to guarantee proper hygiene of the dispensed products.

In order to speed up the sanitising operations, the machine is supplied with spares to replace the parts to be cleaned.

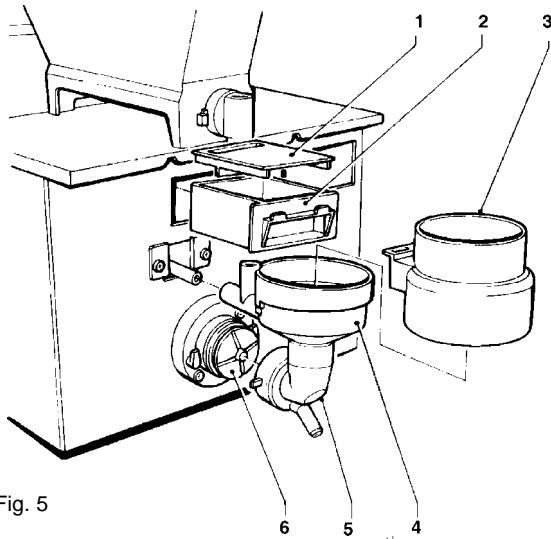

Fig. 5

- 1 - Drawer cover
- 2 - Powder deposit drawer
- 3 - Powder funnel
- 4 - Water funnel
- 5 - Feeder
- 6 - Mixer wheel

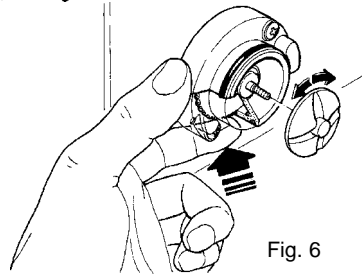

Fig. 6

The parts to be cleaned are:

- powder deposit drawers, mixer and instant drink dispensing conduit;
- tea dispensing spout;
- sugar chute;
- dispensing compartment.
- remove the powder and the water funnels, the feeders, the powder deposit drawers and the mixer wheels from the mixers (see Fig. 5);
- in order to remove the wheels, with a finger block the disk fitted on the mixer shaft;
- wash all parts with detergent being sure that all visible residue and product layers are mechanically removed, using a brush if necessary.

Disinfection should be carried out using chlorine-based detergents.

- soak all components for approx. 20 minutes in a container filled with the previously prepared chlorine-based detergent;
- reinstall the feeders and the water funnels;
- reinstall the powder deposit drawers and the powder funnels after thoroughly drying them.

After reinstalling all parts the following is however required:

- access "Maintenance" mode to clean the mixer (see relevant paragraph) and add a few drops of the chlorine-based detergent in the various funnels.
- After disinfection thoroughly rinse all components to ensure that all residue of the solution is removed.

CLEANING THE WATER SUPPLY TANK (OPTIONAL)

For machines equipped with a water tank inside the support cabinet, at least once a week, such tank must be sanitised with the chlorine-based detergent used for the mixers.

CLEANING THE LIQUID WASTE TRAY

The liquid waste tray can be removed easily for emptying and cleaning.

If the special pins fitted on the container cover are removed and inserted into the special holes (see Fig. 7), the tray can be removed only with door open.

For safety reasons, when removing the tray a special switch installed on the left-hand side will cut off the power supply from the machine.

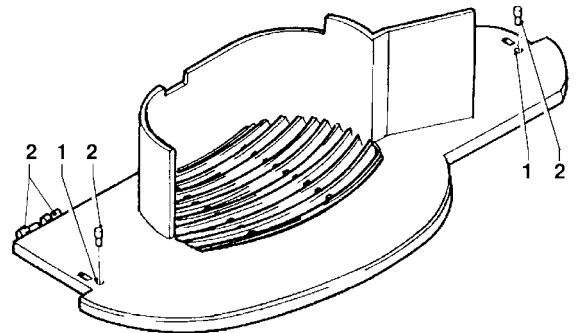

Fig. 7

- 1 - Tray locking holes
- 2 - Pins

CLEANING THE CUP SHIFTING ARM

The cup shifting arm must be periodically removed and cleaned. To be able to remove it, completely undo the knurled nut (see Fig. 8). When reinstalling be sure the spacer washer is correctly fitted.

Fig. 8

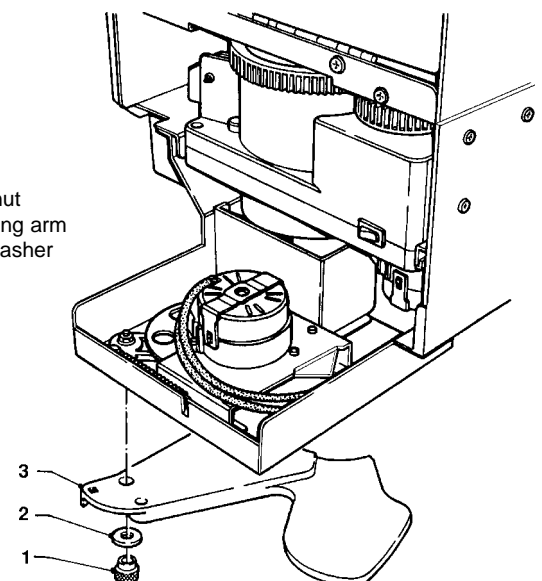

- 1 - Knurled nut
- 2 - Cup shifting arm
- 3 - Spacer washer

CLEANING THE SUGAR RELEASE DEVICE

For models with sugar dispensed directly into the cup, periodically the sugar dispensing system must be cleaned using hot water (see Fig. 9) proceeding as follows:

- release the return spring;
- lift the flexible lever to free the pin
- remove the pin and the dispensing spout;
- after cleaning, reinstall all parts in the reverse order.

Fig. 9

- 1 - Sugar dispensing spout
- 2 - Pin
- 3 - Flexible lever
- 4 - Return spring

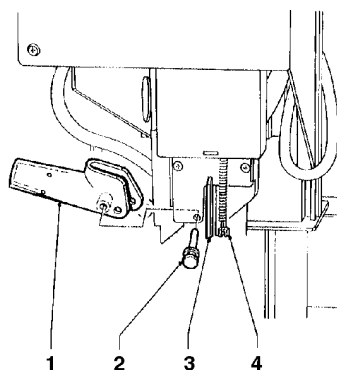
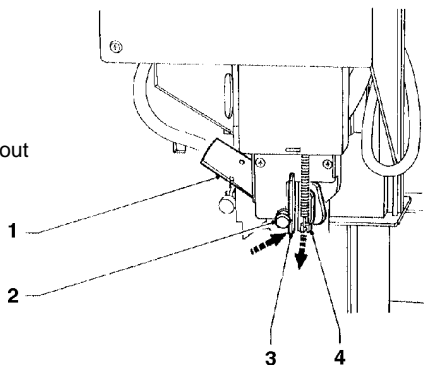

WEEKLY CLEANING OF THE COFFEE UNIT

Every time coffee is refilled, or at least once a week, any powder residue should be removed from the external parts of the coffee unit, especially from the coffee funnel area (see Fig. 17).

SUSPENDING FROM USE

If for any reason the machine is to be switched off for a period exceeding the use-by date of the products, the following will be necessary:

- completely empty the containers and thoroughly wash them with the same chlorine-based detergents used to clean the mixers.
- completely empty the coffee doser unit by dispensing coffee until the empty condition is indicated.
- completely empty the water system using the special clamps.

INSTALLATION

Installation and the following maintenance operations must be carried out by qualified personnel only, trained in the correct use of the machine and informed on the specific risks of such operations.

The machine must be installed in a dry room, where the temperature stays always between 2° C and 32° C.

At installation it is necessary to completely sanitise the hydraulic system and all parts in contact with food, in order to eliminate any possible bacteria formed during storage.

UNPACKING THE VENDING MACHINE

After removing the packing, check that the machine is not damaged.

If in doubt do not use the machine.

No packing elements (i.e. plastic bags, polystyrene foam, nails, etc.) should be left within the reach of children, as they are potentially dangerous.

Packing materials must be disposed of in authorized areas only, and all recyclable materials must be recovered by specialised companies.

Important notice!!

The machine should be positioned with a maximum inclination of 2°.

If necessary provide proper levelling by way of the adjustable feet included (see Fig. 10).

Fig. 10

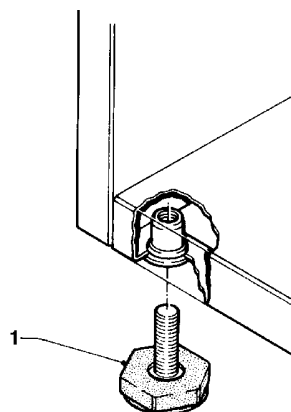

1 - Adjustable foot

INSERTING THE LABELS

The menu and instruction labels are supplied with the machine and must be inserted at the time of installation (see "selection dose" table).

CONNECTING THE MACHINE TO THE WATER MAINS

The machine must be connected to the drinking water mains.

The water pressure must be 5 to 85 N/cm² (0,5-8,5 bar). Run some water from the mains until it is clear and without impurities.

Use a hose (also available as a kit) capable of withstanding the water mains pressure and suitable for use with food-stuff (min. inside diameter of 6 mm) to connect the water supply to the union (3/4" gas) of the water inlet solenoid valve (see Fig. 11).

Fig. 11

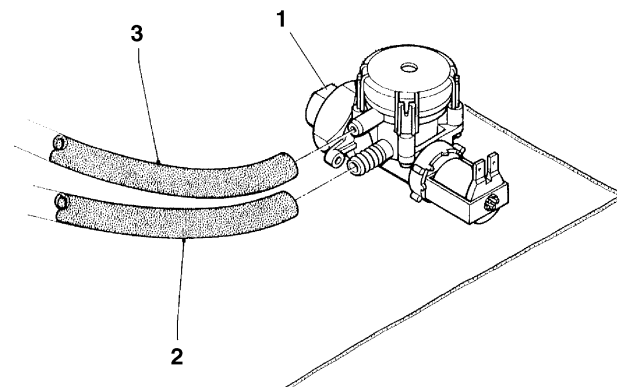

1 - Water inlet union (3/4" gas)
2 - Water supply hose
3 - Overflow hose

It is good practice to install the water supply tap outside the machine in an easily accessible position.

OVERFLOW DEVICE

The water inlet solenoid valve (see Fig. 11) is equipped with an overflow device mechanically preventing the water from flowing in, if there is a malfunction in the solenoid valve itself or in the control device of the boiler water level. To restore normal operation, proceed as follows:

- drain the water contained in the overflow pipe;
- shut off the water supply tap outside the machine;
- loosen the union which secures the solenoid valve supply tube to relieve the water mains residual pressure and then tighten again (see Fig. 11);
- open the tap and switch the machine on.

CONNECTING THE MACHINE TO THE POWER SUPPLY

The machine is designed to operate under a single-phase 230 V~ voltage and is protected by 10 A fuses.

Before making the connection make sure that the ratings correspond to those of the power grid, and more specifically:

- the supply voltage rating should be within the limits recommended for the connection points;
- the main switch should be capable of withstanding the peak load required, and at the same time ensure proper omnipolar disconnection from the power grid with an opening gap of the contacts of at least 3 mm.

The main switch, the power outlet and the plug should be located within easy reach.

The power cable is of the type fitted with a fixed plug. Any replacement (see Fig. 11) should be done by qualified personnel only, using exclusively cables of the type HO5 RN - F or HO5 V V-F or H07 RN-F with a section of 3x1-1,5 mm².

The electrical safety of the machine is ensured only when it is correctly and efficiently earthed according to the safety standards in force.

This fundamental safety requirement must be duly verified, and if in doubt the system must be carefully tested by qualified technicians.

Do not use adapters, multiple sockets and/or extensions.

Before switching the machine on, be sure it is correctly connected to the water mains and the cutoff valve is open.

THE MANUFACTURER DECLINES ALL RESPONSIBILITY FOR ANY DAMAGE CAUSED BY NONCOMPLIANCE WITH THE ABOVE MENTIONED SAFETY RULES.

DOOR SWITCH

When opening the door a special microswitch disconnects the power from the machine electrical system.

With the door open, no energised parts can be accessed. Inside the machine the only energised parts are the ones which are covered with protective casings which are marked with a plate indicating “before removing the cover disconnect the power”.

Before removing these covers it is necessary to disconnect the machine from the mains.

To energize the system with the open door, simply insert the special key into the slot (see Fig. 1).

All operations requiring the machine to be energized with the door open should be carried out with the door switch key inserted, and therefore by qualified personnel informed about the specific risks of such situation.

INSTALLING THE PAYMENT SYSTEM

The machine is sold without payment system, therefore the installer of such a system is responsible for any damage to the machine or to things and persons caused by faulty installation.

- Fit the coin mechanism and make sure that all relevant parameters are programmed correctly;
- adjust the selector opening cam bracket in such a way as to allow the selector to open completely;
- adjust the coin chute according to the type of coin mechanism.

WATER SOFTENER UNIT

The machine is sold without water softener.

Should the water be very hard, a water softener cartridge or an ion-exchange resin water softener unit can be installed in the cabinet.

The water softeners, available as accessory, must be replaced or regenerated regularly following the directions of the manufacturer.

FILLING THE WATER SYSTEM

When the machine is switched on the condition of air-break (full or empty), pump (electrical functioning and water flow) and boiler (pressure) are checked.

If required by the conditions, the machine will automatically start an installation cycle, and namely:

- the display will show "Installation" for the entire duration of the cycle;
- the water mains solenoid valve is opened or the water supply pump is started to fill the air-break;
- (for espresso models only) instant product solenoid valve is opened so that air may be bled from the boiler and 400 cc. of water filled.

N.B.: If there is no water flow during the installation cycle, the machine will lock until the water is resumed or the machine is switched off.

Versions with internal tank

IMPORTANT NOTICE!!!

For models with an internal tank, when the machine is first switched on, the installation procedure MUST BE carried out manually (see relevant chapter).

OPERATION OF THE COFFEE UNIT

COFFEE DISPENSING CYCLE

When selecting coffee, the grinder is started and will continue until the coffee doser chamber is full (see Fig. 16). When the doser unit is full, the ground coffee dose is released into the coffee unit.

The coffee falls into the vertical brew chamber (1) (see Fig. 12).

The ratiomotor handle engaged with the disk (2) located outside of the unit rotates by 180°, causing the brew chamber to swing and lowering the upper piston (3) (see Fig. 13).

Due to the water pressure, the pre-brewing spring (5) sinks and the lower piston (4) goes down 4 mm, thus forming a water cushion which allows an even use of the coffee dose. At the end of the dispensing cycle and during a pause of 3 seconds, the pre-brewing spring (5) will discharge the water through the third way of the dispensing solenoid valve, lightly pressing the used coffee dose.

By completing its rotation, the ratiomotor makes the swinging lever (6) lift the pistons and the coffee dose.

At the same time, when the brew chamber returns to its vertical position, the scraper on the coffee hopper stops the used coffee dose and drops it. The lower piston now returns to the bottom dead centre.

CHECKING AND ADJUSTING THE MACHINE SETTINGS

To get the best results from the product used, the following should be checked:

for coffee

That the used coffee dose is lightly compressed and damp.

The grade of grinding of coffee.

The weight of the ground coffee.

The dispensing temperature.

The water dose.

For instant products

The weight of the instant products.

The drink temperature.

The water dose.

Should the standard settings be varied, proceed as indicated in the next sections of this manual.

The weight of the instant products, the water dose and temperature are directly controlled by the microprocessor. To adjust them it is therefore necessary to follow the programming procedures.

Fig. 12

- 1 - Brew chamber
- 2 - External disk
- 3 - Upper piston
- 4 - Lower piston
- 5 - Pre-brewing spring
- 6 - Swinging lever

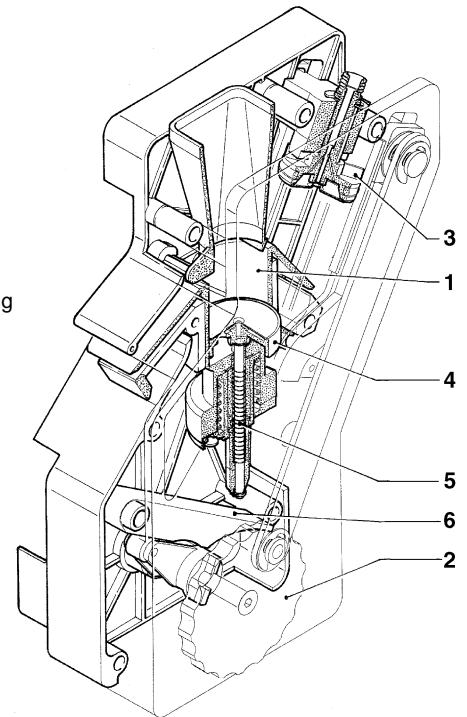
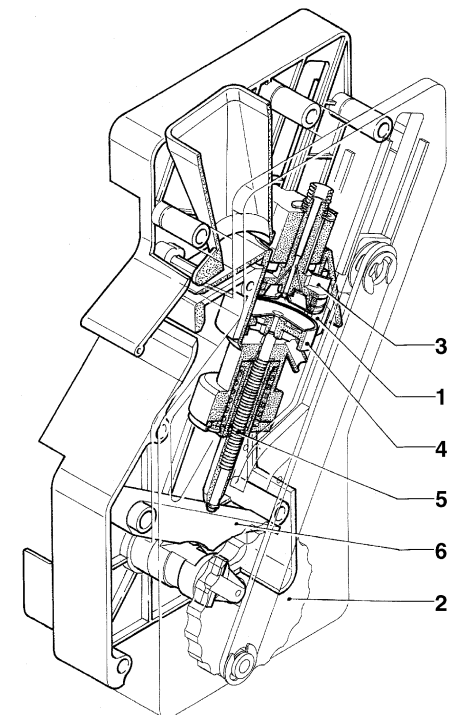

Fig. 13

- 1 - Brew chamber
- 2 - External disk
- 3 - Upper piston
- 4 - Lower piston
- 5 - Pre-brewing spring
- 6 - Swinging lever



STANDARD SETTINGS

The vending machine is supplied with the following settings:

- coffee temperature (at the spout) approx. 85÷89° C;
- instant product temperature (at the spout) approx. 75° C;

The machine standard settings assign the same price, expressed in number of basic units, to all selections

ADJUSTING THE SETTING OF THE COFFEE UNIT PISTON STROKE

When the upper piston is correctly positioned, the coffee unit can operate with coffee doses of 5.5 to 7.5 g.

To change the piston position (see Fig. 14):

- remove the snap ring from its seat;
- place the piston in the proper adjusting notches:
 - .less deep notches for 5.5 to 6.5 g doses;
 - .deeper notches for 6.5 to 7.5 g doses.

Fig. 14

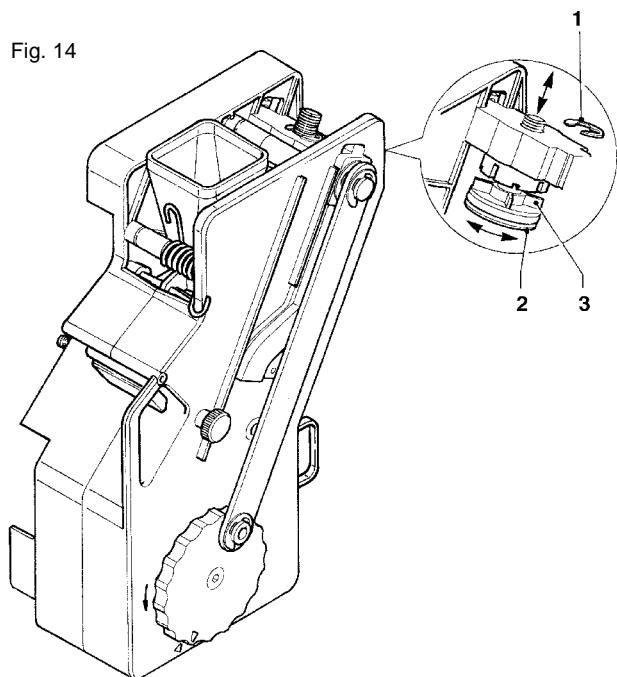

- 1 - Snap ring
- 2 - Upper piston
- 3 - Reference fins

WATER TEMPERATURE CONTROL

If the boiler temperature is to be changed, adjust the special trimmer (see Fig. 20) keeping in mind that:

- tightening will increase the temperature;
- loosening will decrease the temperature;
- the temperature varies by approx. 1° C every 2 turns.

ADJUSTING THE GRADE OF GRINDING

When a variation in the grade of grinding is desired, turn the relevant adjusting knob on the grinder (see Fig. 15) and more specifically:

- turn the knob anticlockwise for coarser grinding;
- turn the knob clockwise for finer grinding.

For optimum results, it is good practice to vary the grade of grinding with the coffee grinder motor running.

N.B.: After adjustment of the grade of grinding, at least 2 test selections must be performed in order to check the new grade of the ground coffee:

the finer the grade of grinding the longer the time necessary for dispensing the coffee and vice versa.

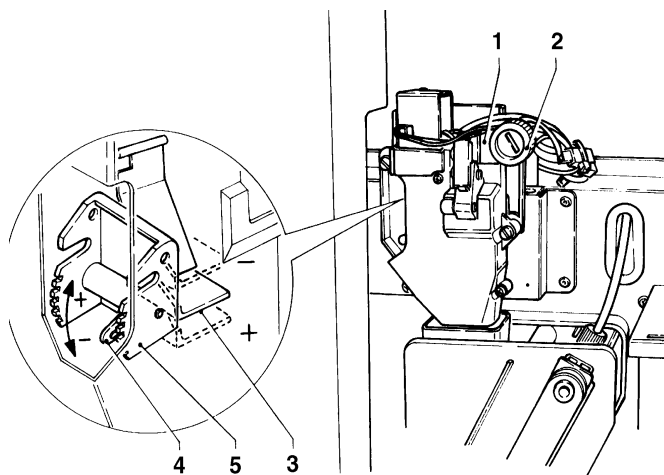

Fig. 15

- 1 - Coffee grinder
- 2 - Grinding adjusting knob
- 3 - Dose regulator
- 4 - Dose adjusting lever
- 5 - Reference notches

ADJUSTING THE COFFEE DOSE

The dose adjusting lever can be positioned in one of the 6 reference notches bearing in mind that:

- the dose is increased by lifting the lever:
- the dose is reduced by lowering the lever:
- every notch changes the dose by approx. 0.25 g.

In addition, when the lever is fully rotated upwards, the ratchet can be released from the groove in the dose regulator (see Fig. 15) and replaced into a different groove to change the average dose setting to:

- low 6 g. \pm 0.5
- medium 7 g. \pm 0.5
- high 8 g. \pm 0.5

To take the dose just remove the coffee unit and press button "2" from of the "maintenance" menu (see relevant section).

Important notice!!!

To refit the coffee unit, pay special attention to the piston position. Reference notches on the external disk and on the unit case should match (see Fig. 18).

CUP SENSOR

The cup sensor is adjusted as to detect the presence of objects (red LED glowing) placed between the sensor lens and the reflector.

The green LED glows when the reading from the reflector is correct.

The sensor's depth of reading is adjusted by turning the trimmer (preset at the factory); the correct setting is approximately 30°, anticlockwise, from the maximum.

For correct operation, the infrared transmitter and the reflector must be kept clean.

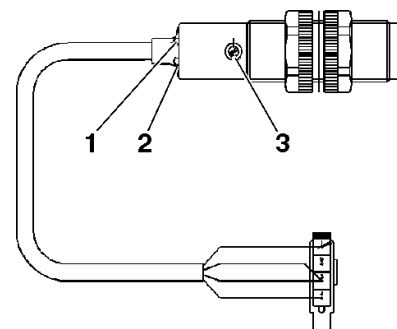

Fig. 16

- 1 - Green LED
- 2 - Red LED
- 3 - Adjustment trimmer

OPERATING MODES

Three different operating modes are provided for the machine, accordingly the buttons may have different functions based on the preset mode of the buttons. The available operating modes are as follows:

DISPLAY	FUNCTIONS
Normal operating mode	
"Ready for use"	coins accepted products dispensed
Maintenance mode	
"Maintenance"	test dispensing machine maintenance
Programming mode	
"Programming"	programming

NORMAL OPERATING MODE

When switching the machine on, the message "Starting" is displayed for a few seconds, after which the machine goes into normal operating mode. The messages displayed according to the current operation are as follows:

DISPLAY	FUNCTION
"Ready for use"	Machine ready.
"Price:...."	Price display selection made
"Credit:....."	Credit display.
"Out of Service"	Machine out of service
"Drink in Process"	Preparation of drink
"Temperature"	Wait time before reaching the operating temperature
"Installation"	Installation under way
"Sel. not avail."	Selection disabled
"Coffee sel. out"	For espresso models only Coffee unit out of service
"Token"	Displayed if the payment system includes pulse sales
"Cup"	Cup present
"Take the drink"	Drink ready

When pressing a pre-selection button for sugar, the messages "Sugar" or "Extra sugar" are displayed for a few seconds.

MAINTENANCE MODE

When the programming button located on the internal side of the push-button board (see Fig. 21) is pressed once the machine will go to "Maintenance" mode.











The message "Maintenance" is displayed for approx. two seconds and then the first option of the "Statistics" menu allowing the following functions:

"Complete Sel."	Dispensing test including cup, sugar and stirrer
"Powder only"	Dispensing powder only
"Water only"	Dispensing water only
"No accessories"	Dispensing test without cup, sugar and stirrer
"Washing"	Washing

At this point the buttons are assigned different functions according to the selected menu.

For complete or partial test dispensing each button control its own selection (see selection dose table).

N.B. For espresso coffee based selections, only the additions are dispensed with the partial dispensing of powder and water; if a selection requires no addition the message "Sel. not avail." will be displayed.

previous function	
next function	
dispensing: coffee	
long coffee	
coffee + milk	
cappuccino	
cappuccino + chocolate	
lemon tea	
chocolate	
milk	

When the display shows "Washing" the buttons are assigned the following functions:

previous function	↑
next function	↓
mixer cleaning	1
unit rotation / coffee release	2
dispensing sugar	3
dispensing extra sugar	4
not used	5
not used	6
not used	7
not used	8

Button "2" is used to operate the coffee unit if this is connected to the electrical system, and it releases a coffee dose if the unit is disconnected.

PROGRAMMING

Pressing the programming button located on the push-button card internal side twice (see Fig. 21), sets the machine to "Programming" mode.

The message "Programming" is displayed for approx. 2 seconds, and after this the first option of the programming menu appears on the display enabling the following functions:

"Present failures"	reading of present failures
"Water dose"	water dose setting
"Powd. dose"	powder dose setting
"Set Prices"	price setting
Set Prices/Select"	price/selection setting enable/disable selections
"Basic unit / DP"	basic coin value setting and decimal point position
"Validator lines"	validator line value setting
"Initialising"	RAM initialising
"Machine code"	machine identification code setting
"Machine Config."	setting the machine version (mains/tank)
"Selec. counter"	setting the number of selections after which the machine will lock.

The following functions are also available:

- failure reset;
- machine installation;
- statistics display;
- statistics printout
- statistics reset.

At this point the buttons are assigned different functions as indicated in the figure below.

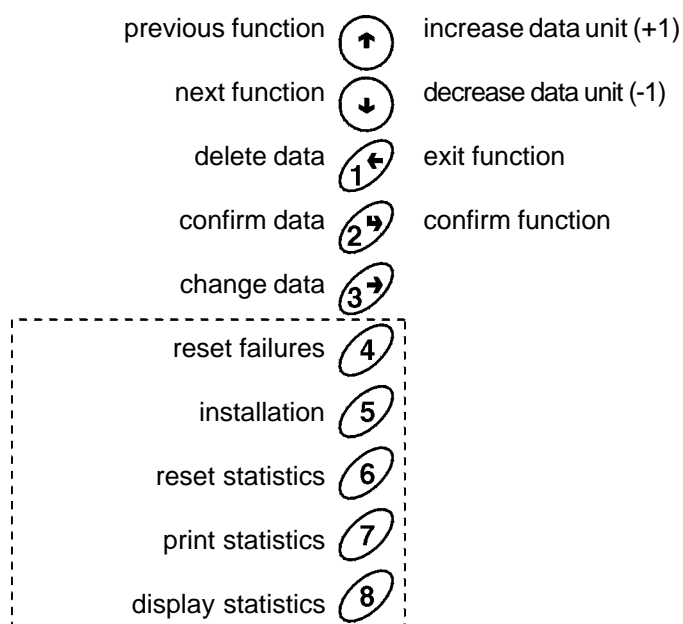

The buttons shown within the dotted line perform direct functions, the ones outside are used to scroll through the menu or to change data.

IMPORTANT NOTICE!!!

WHEN INITIALISING THE MACHINE, THE CONFIGURATION IS GIVEN THE DEFAULT VALUES "SUPPLY FROM THE MAINS/AUTOMATIC CUP DISPENSING".

THEREFORE AFTER INITIALISING, THE MACHINE SHOULD BE RECONFIGURED.

DISPLAYING THE PRESENT FAILURES

When the "Present failure" function from the "programming" menu is displayed, pressing confirm button "➡" will display the error code of the current failure; when pressing button "⬇" the error code of the next applicable failure is displayed.

If no failure is currently present, pressing confirm button "➡" will display the message "No Failure".

The 11 possible failures are shown in the following cases:

AIR-BREAK FAILURE

Models with water supply kit only

The machine will lock if the lack of water condition has not been signalled after 7 selections (Instant models) or after 100 pulses of the volumetric counter (Espresso models).

BOILER FAILURE

The machine will lock if the boiler fails to reach the operating temperature after 10 minutes (Espresso models) or 20 minutes (Instant models) of heating from the machine start, or from the last selection.

COIN MECHANISM FAILURE

The machine will lock if it receives a pulse longer than 2 seconds on a validator line or if there is no communication with the serial coin mechanism for more than 30 seconds.

RAM DATA FAILURE

Data contained in the EEprom (i.e. the chip that stores the setting variations) is wrong and must be retrieved from the Eprom, whereas all statistics information will be lost.

Also the machine configuration is by default and will have to be reconfigured.

The default configuration is the highest available, i.e. automatic machine with water supply from the mains.

WATER FAILURE

Models with water supply from the mains

If the air-break microswitch is closed for approximately 15 seconds, the water inlet solenoid valve will stay triggered until water is resumed.

Models with water supply kit (tank)

If the water level in the tank falls to less than approximately 300 cc.

CUP FAILURE

When the empty cup column microswitch opens, the column shift motor is activated. If after one full turn of the cup dispenser the microswitch is not closed the machine locks.

LIQUID WASTE CONTAINER FULL

This occurs after the liquid waste container float triggers a signal (if this feature is provided).

ROTOR FAILURE

Failed computation of the volumetric counter within a max. given time.

COFFEE UNIT FAILURE

Due to a mechanical lock of the unit or when the unit is not present. The machine will not lock but all coffee based selections are disabled.

COFFEE FAILURE

If after grinding coffee for a period of 15 seconds a dose is not obtained all coffee based selections are disabled.

COFFEE RELEASE FAILURE

If after releasing the ground coffee dose the microswitch of the coffee doser unit indicates the presence of coffee in the doser chamber, all coffee based selections are disabled.

SETTING THE WATER AND POWDER DOSES

When either the "Water dose" or the "Powd. dose" functions are displayed the doses can be varied from the "programming" menu.

The various doses are identified with a dose code, which is displayed each time.

The dose code locates the water and powder doses related to a given selection; changing the doses of a selection will have effect also on composed selections where the dose code is used.

For example, if the water dose for strong coffee is increased, also the dose for cappuccino, composed of strong coffee and milk will be increased.

Refer to the selection dose table for the correspondence to the dose codes.

The values of the doses displayed are expressed in:

- tenths of a second for powder;
- tenths of a second for water on Instant models;
- number of pulses of the volumetric counter for water on Espresso models.

N.B.: Codes "dC" and "dL" for water added to "Milk" selections control water for normal and extra sugar in milk on models with pre-mixed sugar; for unsweetened milk selections the water dose "dC" is added.

These codes have no effect on other versions.

Press the confirm button "⏏" from the "programming" menu to access the dose code list, which can be scrolled with the "↓" and "↑" buttons.

Press the confirm button "⏏" again to display the dose code value.

When pressing the change button "↔", this value is displayed blinking and can be modified as necessary.

SETTING THE PRICES

When the "Set Prices" function of the "programming" menu is displayed, the 8 sales prices stored can be changed.

The prices are indicated as number of basic units.

Press the confirm button "⏏" from the "programming" menu to access the price list, which can be scrolled with the "↓" and "↑" buttons.

Press the confirm button "⏏" again to display the price.

When pressing the change button "↔", this value is displayed blinking and can be modified as necessary.

SETTING THE PRICES AND THE SELECTION STATUS

When the "Set Prices/Selec." (price combination) function of the "programming" menu is displayed, the combination of the selection to one of the stored prices and/or to the status of a selection can be changed.

The prices are indicated as number of basic units.

Press the confirm button "⏏" from the "programming" menu to access the price list, which can be scrolled with the "↓" and "↑" buttons.

When pressing the change button "↔", the selection status is displayed blinking.

Using the "↓" and "↑" buttons the selection status can be changed from (enabled) to (disabled).

Press the confirm button "⏏" again to display the price number referred to in the price table.

When pressing the change button "↔", this value is displayed blinking and can be modified as necessary.

N.B.: The residual credit is controlled by the minidips located on the C.P.U. board. Refer to the "Board configuration" chapter for the settings.

SETTING THE BASIC UNIT AND THE DECIMAL POINT

When the "Basic unit / DP" (basic coin value) function of the "programming" menu is displayed, the value of the basic coin as well as the position of the decimal point can be modified.

Press the confirm button "⏏" from the "programming" menu to display the current value of the basic unit.

Using the "↓" and "↑" buttons the to alternate between the value of the basic coin and the number of the decimal point position "DP", i.e.:

0	disabled decimal point
1	XXX.X
2	XX.XX
3	X.XXX

When pressing the change button "↔", these values are displayed blinking and can be modified as necessary.

PROGRAMMING THE VALIDATOR LINES

When the "Validat. Lines" (line setting) function of the "programming" menu is displayed, the value of the 6 validator coin lines can be changed.

The value of the lines is expressed in number of basic units.

Press the confirm button "⏏" from the "programming" menu to access the list of lines, which can be scrolled with the "↓" and "↑" buttons.

When pressing the change button "↔", this value is displayed blinking and can be modified as necessary.

INITIALISING

When the "Initialising" function is displayed, the machine can be initialised, thus resetting all default data.

This function is used in case of stored data error or replacement of the EPROM.

All statistical data is reset.

Press the confirm button "⏏" and message "Confirm?" is displayed. Press the button "⏏" again to display the message "Working" for a few seconds.

Also the machine configuration is by default and will have to be reconfigured.

The machine default configuration is with water supply from the mains.

SETTING THE MACHINE CODE

When the "Machine code" function is displayed the identification code number of the machine can be changed (from the default 0000 to a number up to 9999).

Press the confirm button "➡" to display the current code; when pressing the change button "↔" the first digit will blink.

The buttons will have numeric values.

When pressing a button, the blinking digit will be given the displayed value and the next digit starts blinking.

MACHINE CONFIGURATION

When the "Machine Config." function is displayed, the machine configuration can be changed, and namely:

- water supply from the mains / internal tank
- for instant models, before releasing the cup, dispensing 20 cc. of water to heat the coffee mixer; this function can either be enabled or disabled

Press the confirm button "➡" to display the current status; when pressing the change button "↔" the status blinks and can be changed with the "↓" and "↑" buttons.

IMPORTANT NOTICE!!!

When the machine is initialised, the configuration will be assigned the default values: "Water supply from the mains/mixer heating enabled".

AFTER INITIALISING THE MACHINE MUST BE RECONFIGURED.

SELECTION COUNTER

This function is used to lock the machine after a preset number of coffee selections, and a preset number of instant selections.

Since this is a control tool used only by the vending manager, a 4-digit password must be entered.

After entering the password, the number of selections, after which the machine locks, can be set, the number of selections already made can be read and the lock counter can be reset.

N.B.: The counters are set to zero by default;

With the counters set to zero, this function is disabled.

INSTALLATION

Pressing the installation button "5" will enable the filling operation of the hydraulic system, even with the air break full.

RESETTING FAILURES

When pressing the failure reset button "4" the message "Working" is displayed for a few seconds and all current failures will be reset.

DISPLAYING THE STATISTICS

Press the statistics display button "8" to display in a sequence and at 1 second intervals, if no other buttons are pressed, the stored data (see table VI):

- 1 - single selection counter;
- 2 - single price counter;
- 3 - counter per type of coin cashed;
- 4 - total cash counter;
- 5 - failure counter.

PRINTING THE STATISTICS

The statistics described in the section "displaying the statistics" can be printed with a RS-232 serial printer with a Baud rate of 9600, 8 data bit, no parity, 1 stop bit, connected to the serial port located on the push button board (the CITIZEN I-DP 3110-24RF 230 A p/n 9210219 printer is recommended). The hardcopy printout will also contain the machine code number and the printout progressive number.

The progressive hardcopy printout number can be reset only by initializing the machine.

To connect the printer do as follows:

- Press the statistics print button "7" to display the message "Confirm?";
- before confirming connect the printer;
- press the confirm button "➡" to start printing.

RESETTING THE STATISTICS

Press the statistics reset button "6" to display the message "Confirm?" blinking.

Press the confirm button "➡", the message "Working" is displayed for a few seconds and the statistics are reset.



PROGRAMMER (OPTIONAL)

AUTOMATIC SETUP TRANSFER

Using the programmer device makes it possible to read out the programming routines set and transferred to other apparatuses from a given vending machine.

These data are preserved also when the programmer is disconnected thanks to a couple of Duracell batteries LR03 Format AAA 1.5 V (to be replaced every 12 months). The programmer allows up to twenty different programs (setups) to be stored.

To identify, among the 20 setups available, those containing data, a special character is displayed, and more precisely:

< - > = Setup free

< □ > = Setup with data.

When creating the setup only the programs containing data are available; if no setup contains data, the message "no data available" will appear on the programmer display. The special holder (see Fig. 17) is used to connect the programmer to the machine, connecting the cable to the special connector of the push-button board (see Fig. 21). Then enter the "programming" mode and press twice the relevant button on the push-button board (see Fig. 21). Now, by inserting the programmer in its holder, an automatic connection will take place, and the setup menu will be shown on the programmer display:

- Pressing button "E" will access the displayed function;
- Pressing button "O" will display the following function;
- Pressing button "C" will display the previous function.

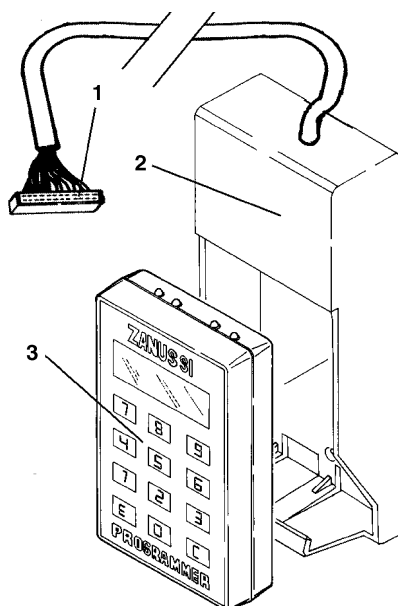

Fig. 17

- 1 - Connector
- 2 - Programmer holder
- 3 - Programmer

PROGRAMMER SETUP READING	SETUP READING SETUP 01 <X>	SETUP 01 <X> Confirm?
	SETUP READING SETUP 20 <X>	
PROGRAMMER CREATE SETUP	CREATE SETUP SETUP 01 <X>	SETUP 01 <X> Confirm?
	CREATE SETUP SETUP 20 <X>	

TRANSFERRED DATA

Data transferred with the set up is as follows:

- Water doses
- Powder doses
- 8 price table
- Prices/selection status
- Basic unit
- Decimal point position
- Validator lines value
- Machine lock counter

SETTING THE LANGUAGE

It is possible to change the programmer configuration as concerns the language in which the messages are to be displayed as well as to reset all of the data therein contained. To activate the "Programmer configuration" operate as follows:

- insert the programmer into the holder and start the machine.
- wait approx. 10" and then press the programmer buttons "C" and "O"; the first function will be thus displayed:

LANGUAGE CONFIGURATION	CONFIGURATION ITALIAN	CONFIGURATION Confirm?
	CONFIGURATION FRENCH	
	CONFIGURATION GERMAN	
	CONFIGURATION ENGLISH	
	CONFIGURATION SPANISH	
CONFIGURATION	INITIALISE INITIALISE	Confirm?
CONFIGURATION CONFIG. END	Exit from the configuration menu The software starts again from address 0000 (as when the machine is started)	

MAINTENANCE

Important notice!!

Access to the machine interior for maintenance and/or repairs is via the back panel.

Therefore, provisions must be made for the machine to be rotated, thus allowing removal of the back panel.

The integrity of the vending machine and its conformity with the rules and regulations in force for its relevant systems must be checked by qualified personnel at least once a year.

Switch the machine off before any maintenance operations which require removal of components.

The following operations must be carried out only by personnel who have the specific knowledge of the machine functioning from a point of view of electrical safety and health regulations.

INTRODUCTION

To ensure perfect operation for a long period, the machine must be subjected to regular maintenance.

The following sections contain the procedures and the maintenance schedule, which are only a general indication, as they greatly depend on the operating conditions (e.g. water hardness, environmental humidity and temperature, type of product used, etc.).

The procedures described in this chapter are not exhaustive of all maintenance operations to be carried out.

More complex operations (e.g. boiler descaling) should be carried out by qualified technicians only having specific knowledge of the machine.

To prevent oxidation or the action of chemical agents, the stainless steel and varnished surfaces should be kept clean by using mild detergents (solvents must not be used).

Never use water jets to clean the machine.

BREWING UNIT MAINTENANCE

Every 10,000 selections or every 6 months some maintenance of the coffee unit must be carried out.

Maintenance is carried out as follows:

- remove the boiler teflon hose connection from the upper piston, paying attention not to lose the seal (see Fig. 18);
- undo the knob securing the unit to the bracket;
- remove the brewing unit.

Removing the upper filter

- Take the snap ring out of its seat;
- remove the piston from the crosspiece;
- remove the filter and the piston sealing.

Removing the lower filter

- Loosen screws A and B enough to release the coffee funnel (see Fig. 18);
- remove the lower piston snap ring;
- take the piston from out of brew chamber and remove the filter.

Soak all components removed from the unit in a solution of boiling hot water and coffee machine detergent for approx. 20 minutes.

Thoroughly rinse and dry all parts, then reinstall them in the reverse order of disassembly, taking particular care that:

- the piston is positioned in the correct notch for the coffee dose used (see relevant section);
- the two reference notches match and that the coffee unit is inserted.

Important notice!!!

Check that the handle pin of the ratiomotor is correctly engaged in its seat.

Fig. 18

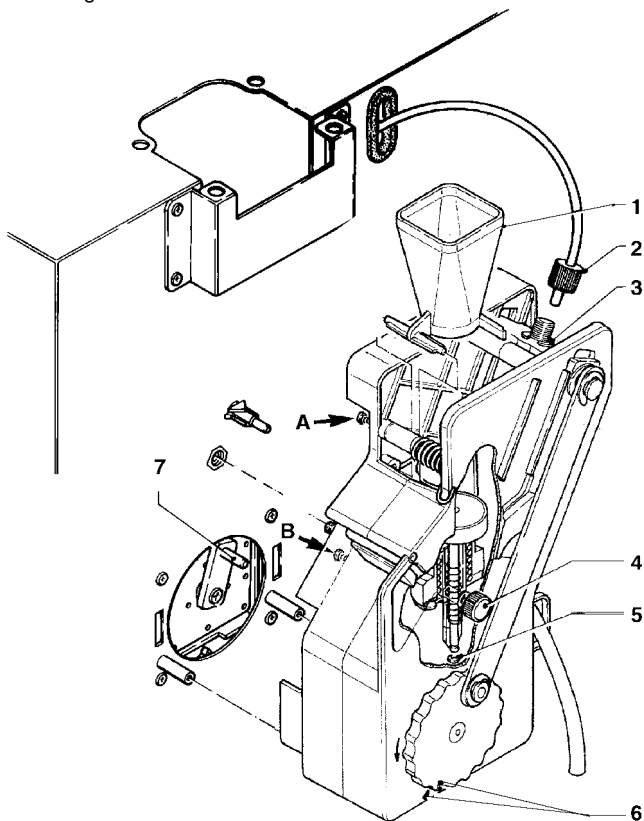

- 1 - Coffee funnel
- 2 - Boiler connecting hose
- 3 - Unit securing knob
- 4 - Upper piston snap ring
- 5 - Lower piston snap ring
- 6 - Reference notches
- 7 - Ratiomotor handle pin

ANNUAL SANITISING

At least once a year, or more frequently according to the use of the machine and the quality of the inlet water, the entire foodstuff circuit system must be cleaned and sanitised in the following way:

- all parts of the hydraulic system in contact with food, including the hoses, must be removed from the unit and fully disassembled;
- wash all components with detergents, ensuring that all visible residue and product films are mechanically removed using brushes or similar tools, if necessary;
- all components must be soaked in a sanitising solution for at least 20 minutes;
- the unit internal surfaces are to be cleaned with the same sanitising solution;
- Thoroughly rinse and then reinstall the parts.

Before restarting the unit, the same sanitising procedure described in section "Sanitising the foodstuff circuits and the mixers" should be repeated with the components reassembled"

PRINTED BOARD FUNCTIONS AND INDICATOR LIGHTS

CONTROL BOARD

This board (see Fig. 19) processes the information from the push-buttons and from the payment system, it also controls the actuators and the push-button board.

The 15 V AC voltage required for board operation is supplied by a transformer which is protected by a 125 mA T fuse on the primary and by a 1.25 AT fuse on the secondary winding. The voltage supply is rectified and stabilised directly by the board.

The board also houses the EPROM.

- the yellow LED indicates the presence of 12 V DC;
- the green LED, when blinking indicates that the micro-processor is working correctly;
- the red LED indicates the operating status of the boiler heating element.

Fig. 19

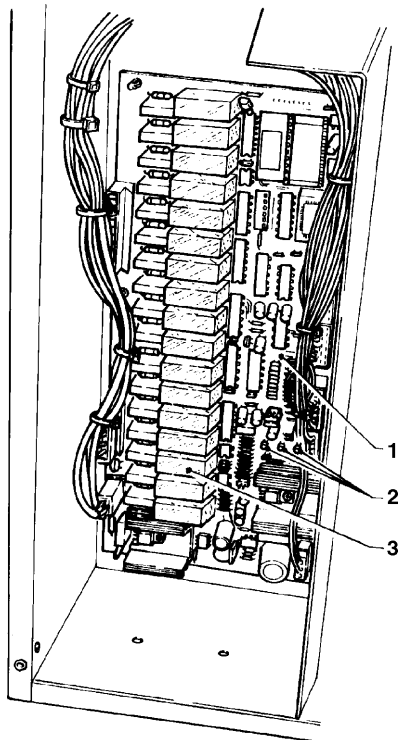

- 1 - Control board
- 2 - LED
- 3 - Relay

PUSH-BUTTON BOARD

This board controls the alphanumeric display, the selection buttons and the programming button.

It supports the coin mechanism connectors (MDB or Executive as alternative) as well as the printer port.

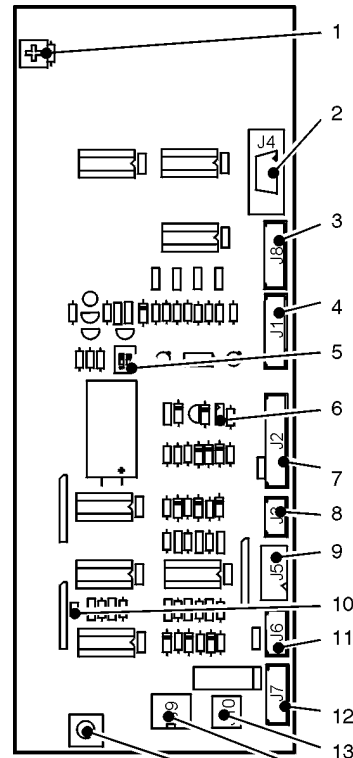

Fig. 20

- 1 - Brightness adjustment trimmer
- 2 - Printer
- 3 - Programmer connector
- 4 - To the control board
- 5 - Payment system minidip
(1-2 OFF = Executive - ON = MDB)
- 6 - Jp2 =
- 7 - To the control board
- 8 - Executive serial interface
- 9 - Front validator
- 10 - Jp1 =
- 11 - Coin return lamp
- 12 - not used
- 13 - MDB coin mechanism power supply
- 14 - MDB coin mechanism
- 15 - Programming button

CONFIGURING THE CONTROL BOARD

The electronic board was designed to be used on different machine models.

In case of replacement it must be checked that the new board is correctly configured.

A set of 8 minidips (3), allowing configuration of the board for use in the various versions and in the different countries, and a jumper (5), allowing configuration of the board for Instant or Espresso models, are located at the centre of the board (see Fig. 22). The board is also designed to support 512 Kb and 1 Mb EPROMs by setting jumpers JS3 and JS4.

To correctly configure a board in case of replacement or to change the machine performance, refer to the following tables and to the selection dose table.

Fig. 21

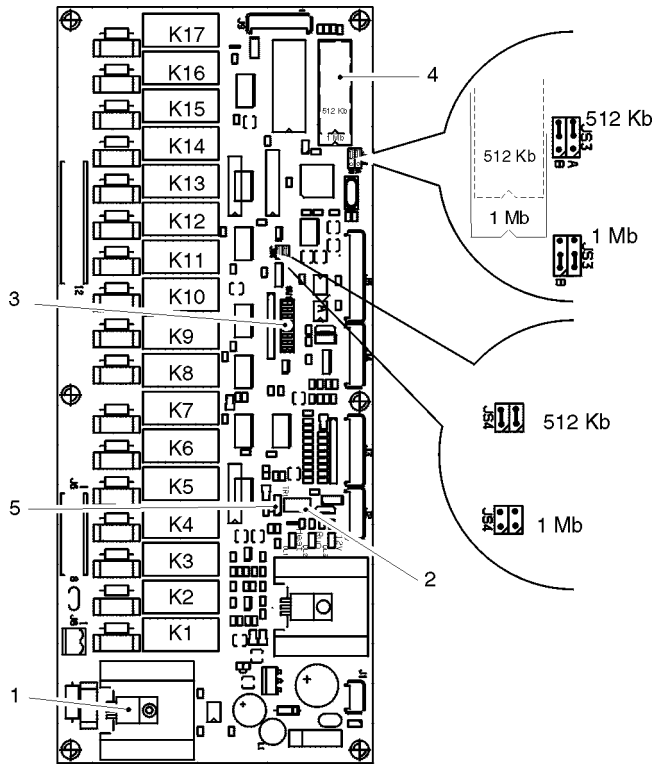

- 1 - Triac of the boiler heating element
- 2 - Temperature control trimmer
- 3 - Configuration minidips
- 4 - EPROM
- 5 - Jumper: 1-2 Instant versions
2-3 Espresso versions
- JS3 - JS4 EPROM size jumpers

RELAY FUNCTION (see Wiring diagram)

	ESPRESSO	INSTANT
K1	= ER	MF2
K2	= ESC	MF1
K3	= MAC	MD1
K4	= PM	PM/EIA
K5	= M	EV3
K6	= EV2	EV2
K7	= EV1	EV1
K8	= MF1	MF4
K9	= MD4	MD5
K10	= MD3	MD4
K11	= MD2	MD3
K12	= MD1	MD2
K13	= MSB	MSB
K14	= MSP	MSP
K15	= MSCB	MSCB
K16	= EIA	EV4
K17	= MF2	MF3

CONFIGURING THE MODEL

According to the model, minidip 5 and the jumper (see Fig. 21) shall be set as follows:

MODEL	INSTANT	ESPRESSO
MINIDIP 5	ON	OFF
JUMPER	1-2	2-3

CONFIGURING THE STIRRER DISPENSER

The unsweetened drinks can be dispensed with or without stirrers by setting minidip 2 to:

STIRRER	dispensed with unsweetened selections	not dispensed with unsweetened selections
MINIDIP 2	ON	OFF

CONFIGURING THE PAYMENT SYSTEM

(versions with front coin mechanism)

For versions fitted with a front coin mechanism, the board can be configured to operate with a 12 V validator by setting minidips 1,3,4 and 8 as follows:

MINIDIP	ON	OFF
1		fixed to OFF
3 (validator only)	credit control	no credit control
4		validator
8		fixed to OFF

CONFIGURING THE PAYMENT SYSTEM

(versions with Serial coin mechanism)

The configurations available for serial payments systems are as follows:

SERIAL SYSTEM	DIP 3	DIP 4	DIP 8
Executive std. U-key URW 2	OFF	OFF	OFF
Executive price holding (parameter 36 = 3)	OFF	ON	OFF
ECS system	ON	OFF	OFF
U-Key URW3	OFF	OFF	ON

Important notice:

Minidips which are not mentioned are to be set to OFF.

HYDRAULIC SYSTEM

Espresso models

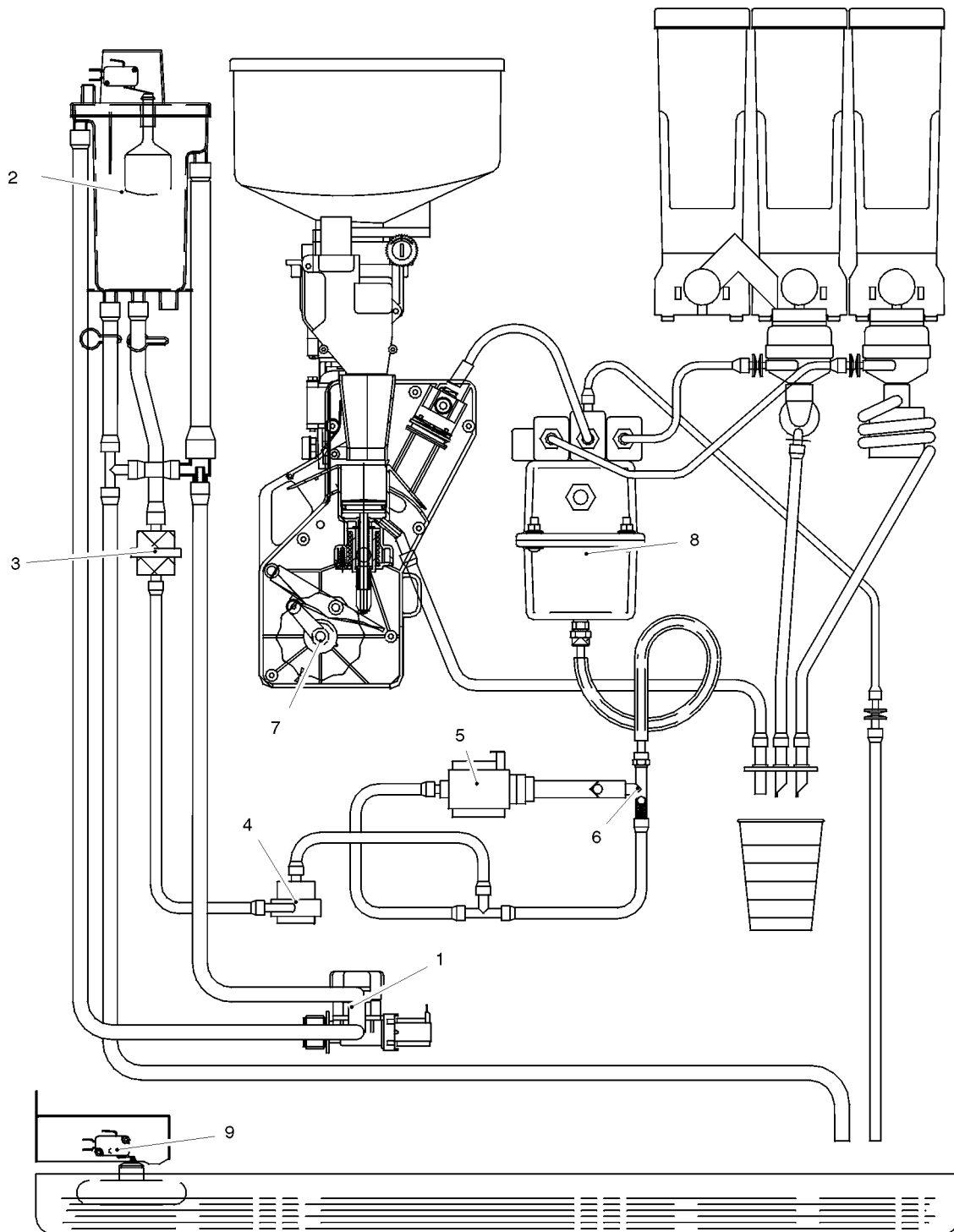

- 1 - Water inlet solenoid valve
- 2 - Air-break
- 3 - Mechanical filter or softener cartridge (optional)
- 4 - Volumetric counter
- 5 - Vibration pump

- 6 - Bypass
- 7 - Coffee unit
- 8 - Boiler
- 9 - Liquid waste container float

HYDRAULIC SYSTEM

Instant models

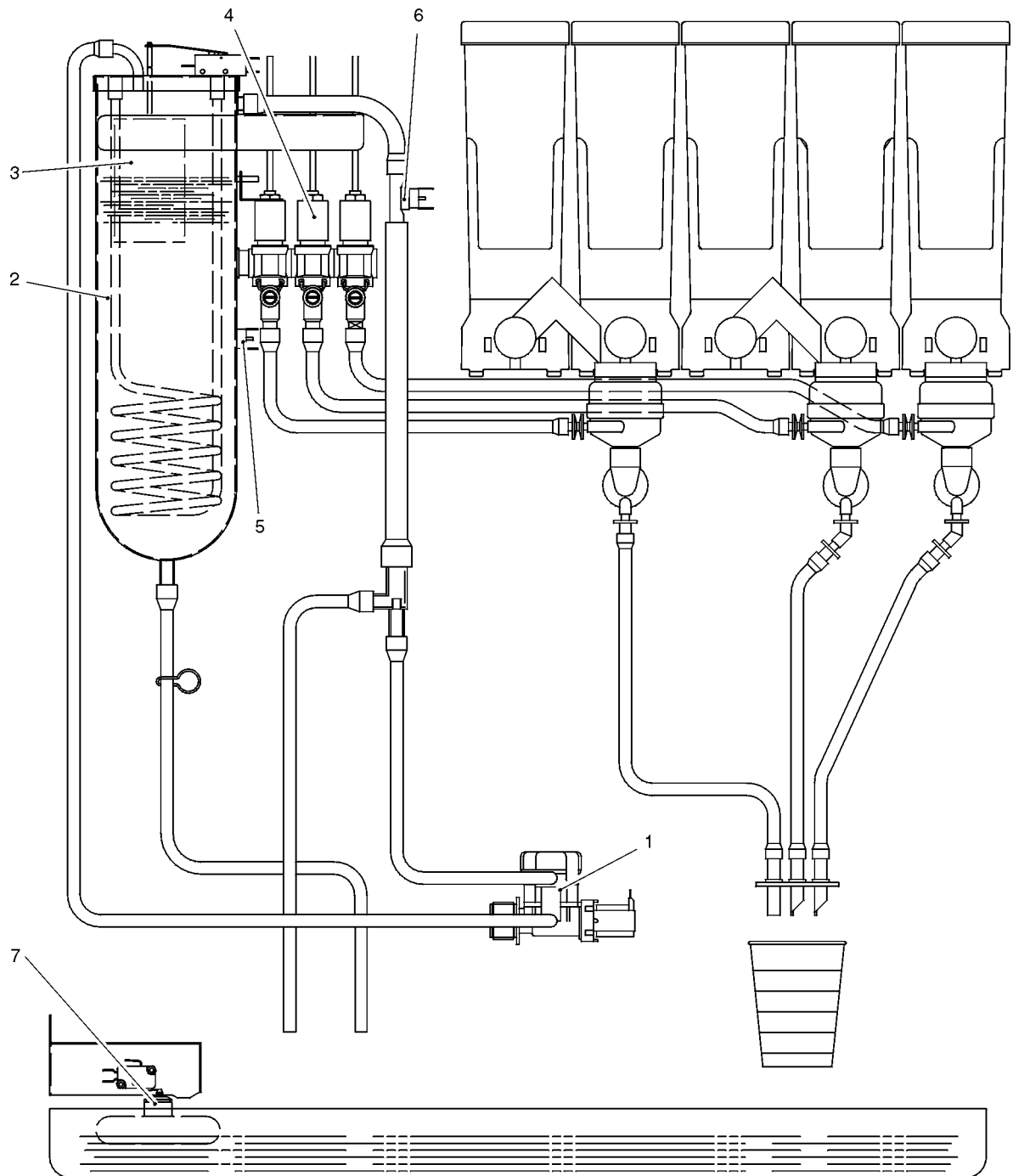

- 1 - Water inlet solenoid valve
- 2 - Boiler
- 3 - Float
- 4 - Instant product solenoid valve
- 5 - Safety thermostat (manual reset)
- 6 - Anti-boiling thermostat (manual reset)
- 7 - Liquid waste container float

HYDRAULIC SYSTEM

Equipped support cabinet

self-contained water supply and softener unit (optional)

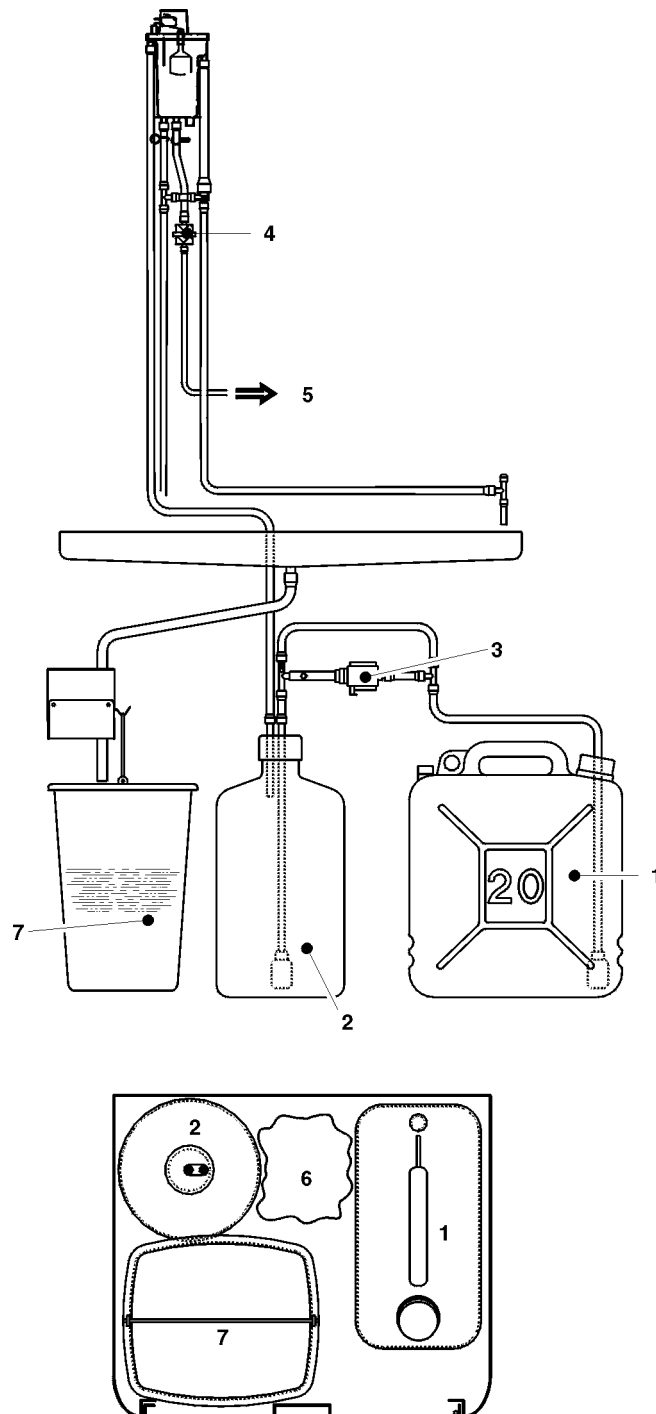

- 1 - Water tank
- 2 - Water softener (optional)
- 3 - Water supply pump
- 4 - Mechanical filter

- 5 - To the machine
- 6 - Coffee grounds bag
- 7 - Liquid waste container

Programming menu

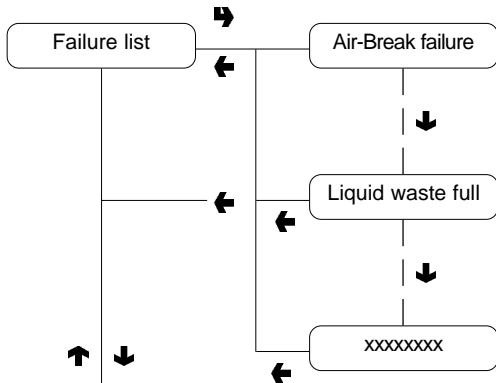

FAILURE DISPLAY

If no failures are present, when pressing button  the message "No failures" is displayed for 1 second

LIST OF FAILURES

- N. 1 - Air-Break
- N. 2 - Boiler
- N. 3 - Payment system
- N. 4 - EEprom data
- N. 5 - Water failure
- N. 6 - Cup failure
- N. 7 - Liquid waste full
- N. 8 - Volumetric counter
- N. 9 - Coffee unit
- N. 10 - Coffee failure
- N. 11 - Coffee release

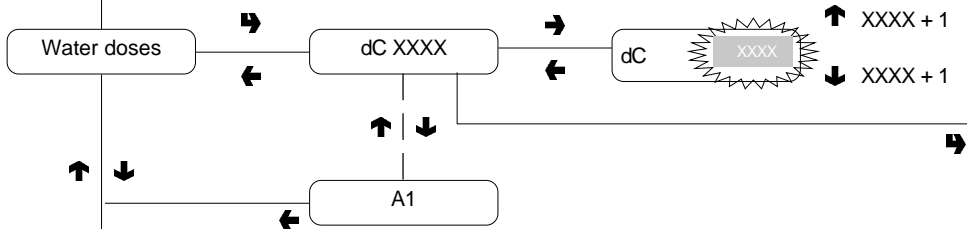

WATER DOSES

Refer to the selection dose table for the correspondence between dose code and water dose

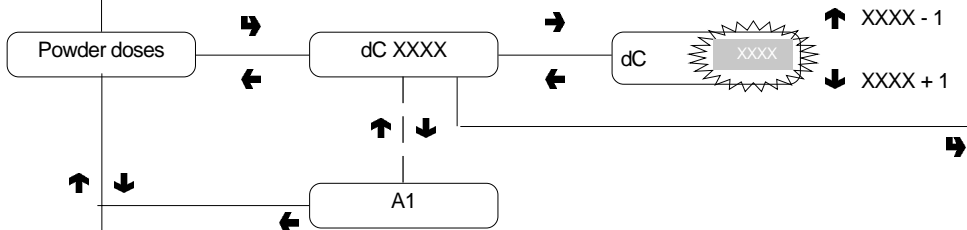

POWDER DOSES

Refer to the selection dose table for the correspondence between dose code and powder dose

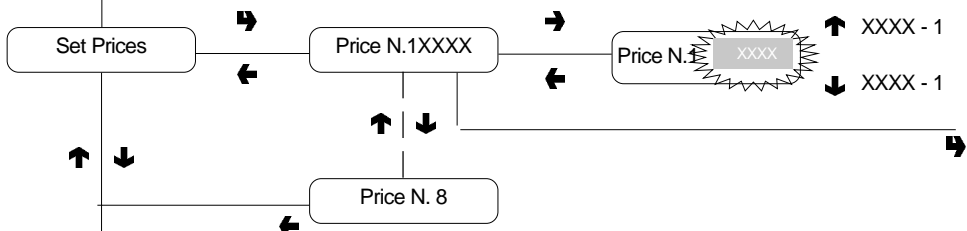

PRICE VALUE

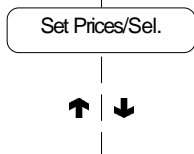

PREVIOUS FUNCTION/
DECREASE DATA UNIT (-1)



NEXT FUNCTION/
INCREASE DATA UNIT (+1)



DELETE DATA/
EXIT FUNCTION



CONFIRM DATA/
CONFIRM FUNCTION



CHANGE DATA



Programming menu

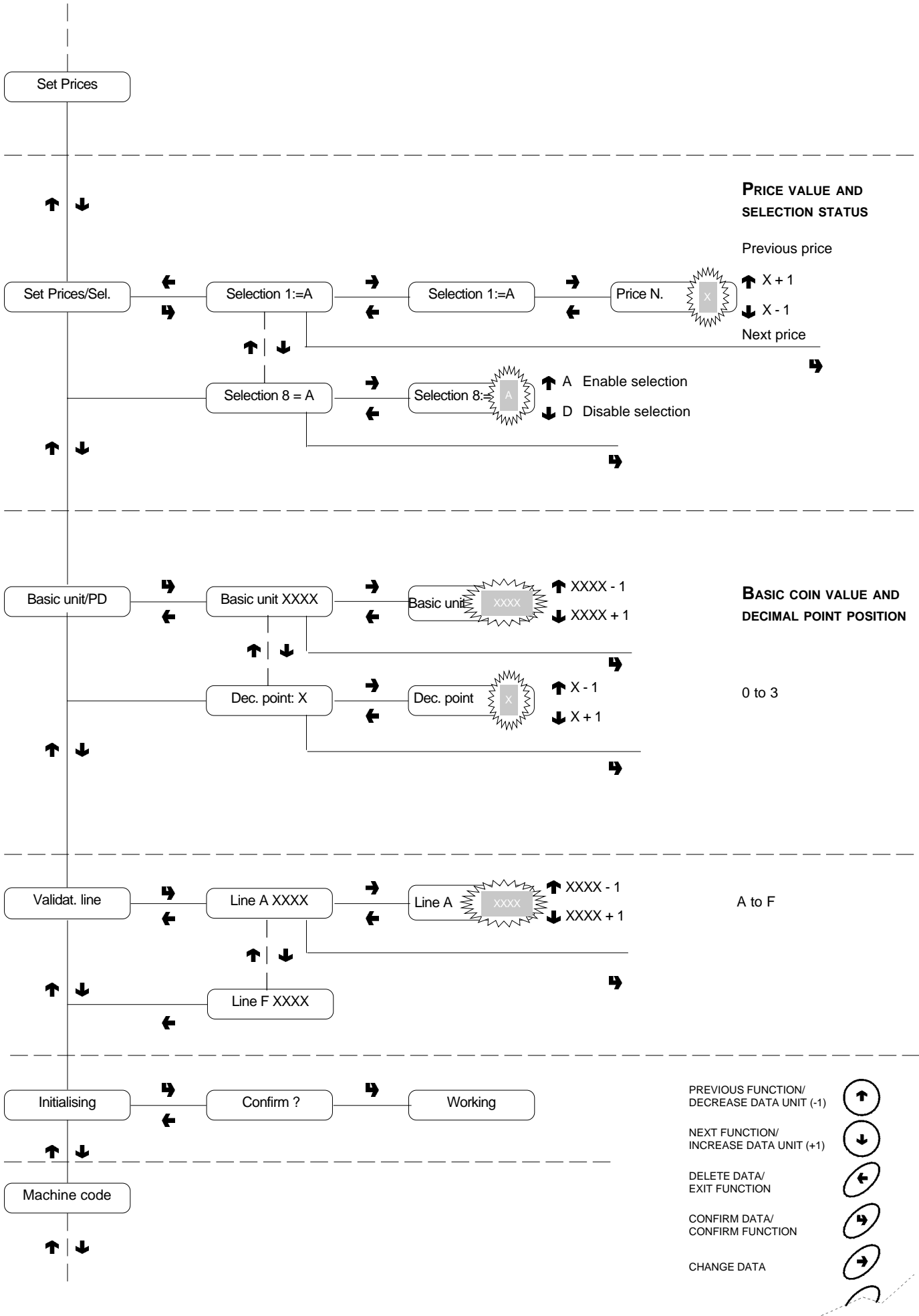

Programming menu

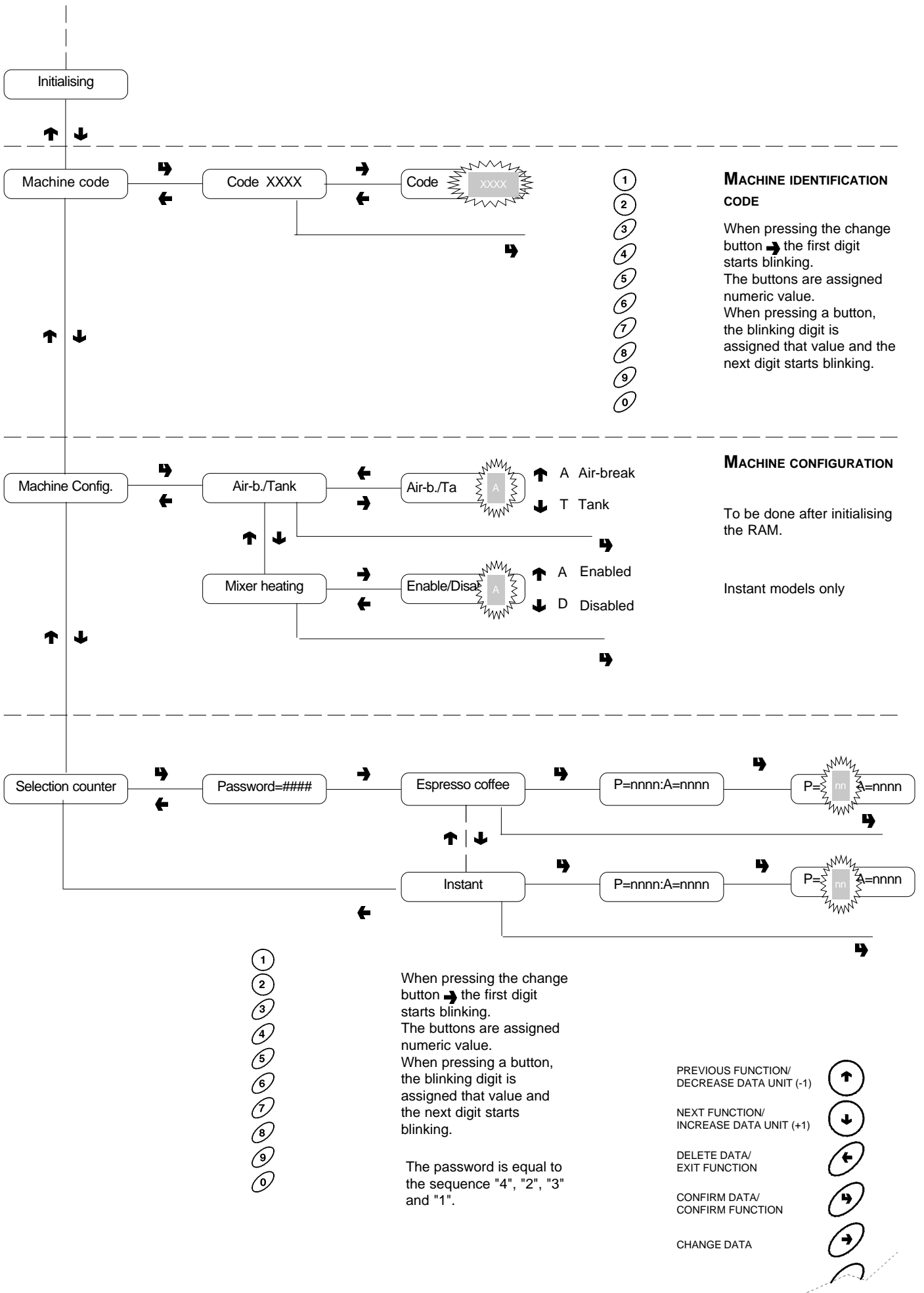

Data reading

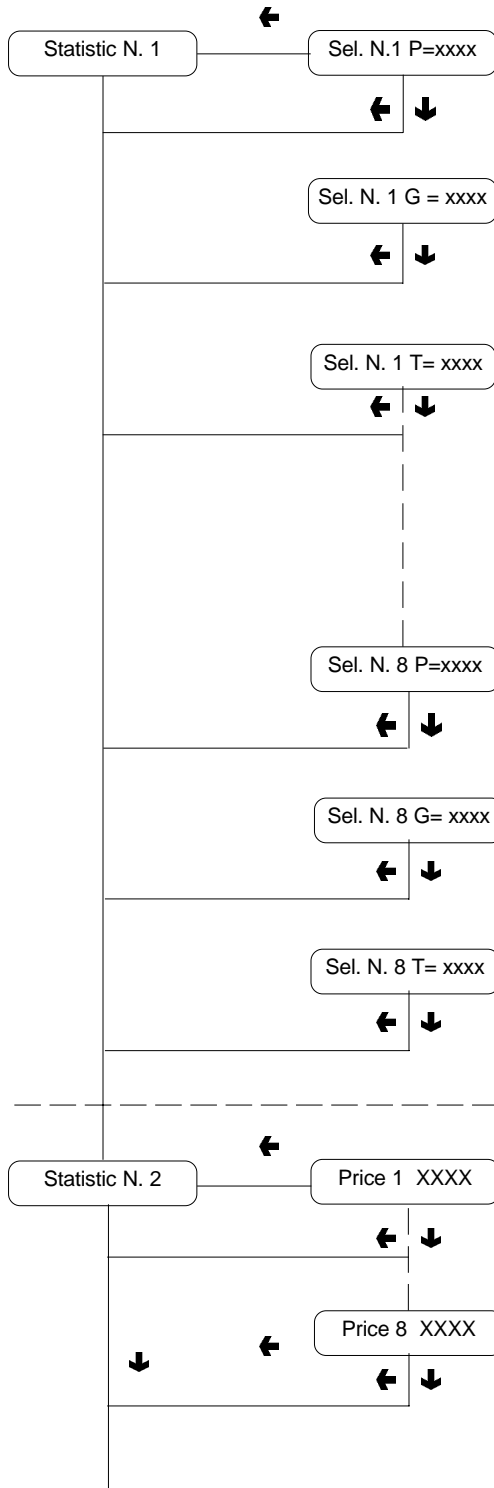

P = paid selections

G = free selections

T = test selections

DISPENSING BY SELECTION

Press button "8" to display statistics for each selection (1 - 8)

DISPENSING BY PRICE

PREVIOUS FUNCTION/
DECREASE DATA UNIT (-1)



NEXT FUNCTION/
INCREASE DATA UNIT (+1)



DELETE DATA/
EXIT FUNCTION



CONFIRM DATA/
CONFIRM FUNCTION



CHANGE DATA



DISPLAY STATISTICS



Data reading

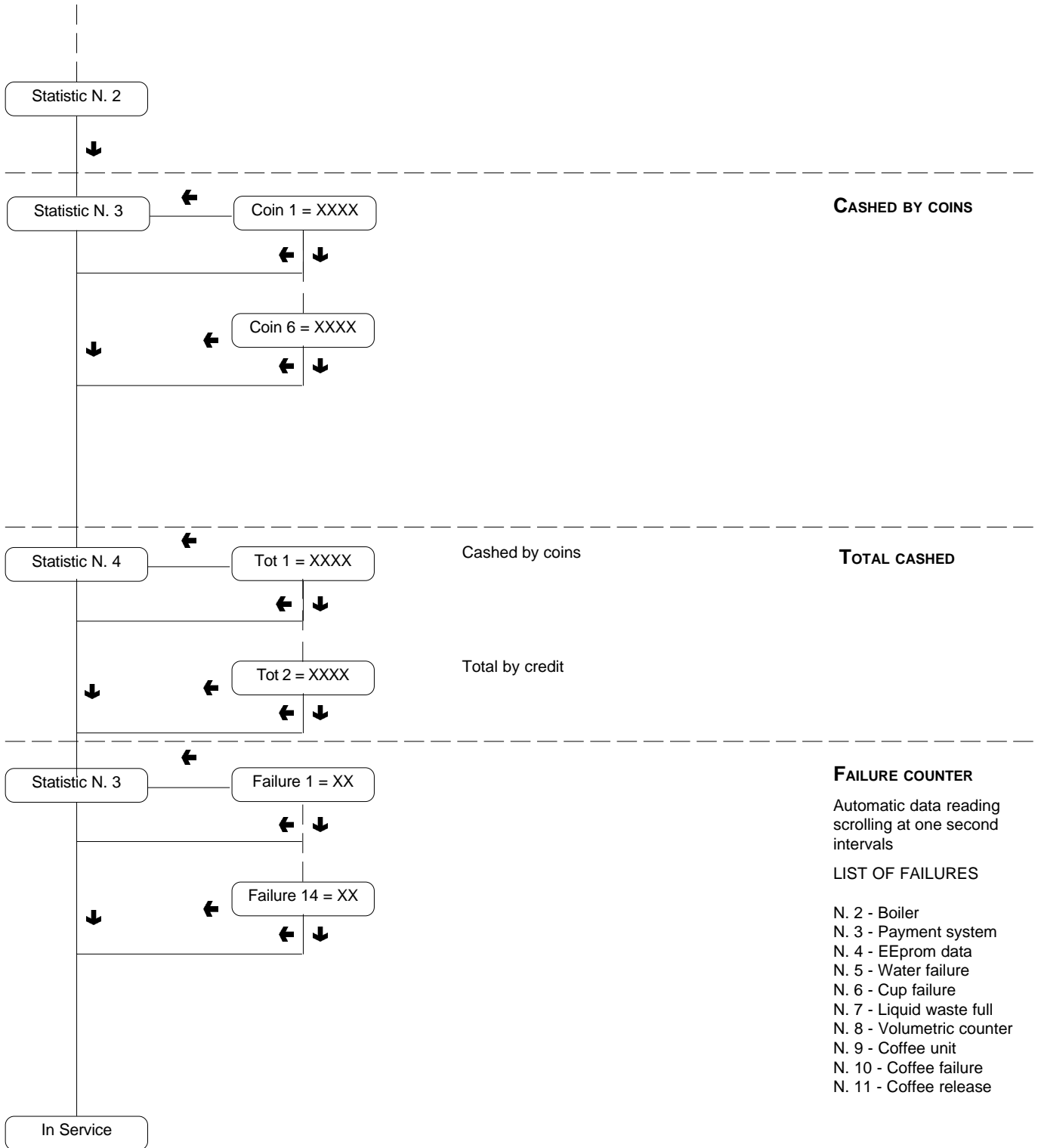

CASHED BY COINS

TOTAL CASHED

FAILURE COUNTER

Automatic data reading scrolling at one second intervals

LIST OF FAILURES

- N. 2 - Boiler
- N. 3 - Payment system
- N. 4 - EEprom data
- N. 5 - Water failure
- N. 6 - Cup failure
- N. 7 - Liquid waste full
- N. 8 - Volumetric counter
- N. 9 - Coffee unit
- N. 10 - Coffee failure
- N. 11 - Coffee release

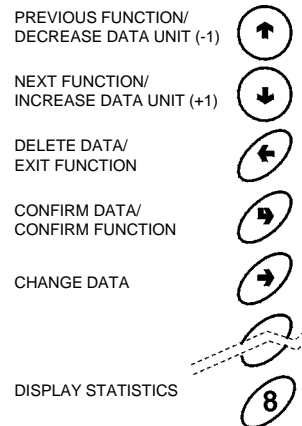

WIRING DIAGRAM LEGEND

CODE	DESCRIPTION	CODE	DESCRIPTION
BDV	BDV COIN MECH CONNECTORS	MDZ	DOSING DEVICE MOTOR - SUGAR
BFL	LIQUID WASTE TRAY SWITCH	MF1-..	WHIPPER MOTOR
CCG	GENERAL COUNTER	MFB	FRESH-BREW MOTOR
CM1-2	MICROSWITCH FOR BREW UNIT MOTOR	MPF	FRESH BREW PISTON MOTOR
CM3	CUP TRAY MICROSWITCH	MSB	CUP RELEASE MOTOR
CMCB	CUP CONTAINER MOTOR MICROSW.	MSCB	CUP CONTAINER SHIFT MOTOR
CMF	FRESH BREW MOTOR CAM	MSP	STIRRER RELEASE MOTOR
CMPF	FRESH BREW UNIT PISTON MICROSWITC	MSV	TRAY SHIFT MOTOR
CMSB	CUP RELEASE MOTOR CAM	NTC1-.	TEMPERATURE PROBE
CV	VOLUMETRIC COUNTER	PD	DIODE RECTIFIER
E1-...	INSTANT SOLENOID VALVE	PG	UNIT DETECTION MICROSWITCH
EEA	WATER INLET SOLENOID VALVE	PIP	PROGRAMMING BUTTON
ER	COFFEE DISPENSER SOLENOID VALVE	PL	WASH CYCLE BUTTON
ESC	COFFEE RELEASE MAGNET	PM	PUMP
EX	EXECUTIVE COIN MECH CONNECTOR	PR	PRESSURE SWITCH
FA	RADIO INTERFERENCE SUPPRESSOR	PSB	CUP RELEASE BUTTON
FREE	FREE VENDING SWITCH	RCC	COFFEE BOILER HEATING ELEMENT
FS1-..	FUSE	RCS	INSTANT BOILER HEATING ELEMENT
ID	COFFEE DOSE SWITCH	RIS	COFFEE UNIT HEATER
IMSP	STIRRER RELEASE MICRO-SWITCH	RT	BALLAST
IP	DOOR SWITCH	SAL	VOLTAGE SUPPLY BOARD
IPF	WASTE CONTAINER OVERFLOW SWITCH	SM	CONTROL BOARD
IVA	EMPTY BOILER MICRO-SWITCH	SP	PUSH-BUTTON BOARD
IVB	EMPTY CUP DISPENSER MICRO SWITCH	ST	STARTER
JUG	JUG FACILITIES SWITCH	TH	THERMOSTAT
KC1-..	COFFEE BOILER CUTOUT	TR	TRANSFORMER
KS1-..	SAFETY CUTOUT	TR1	TRANSFORMER - 230 V 24 V
LF1-..	LAMP	TX....	DELAYED FUSE (X=COURRENT)
M	COFFEE UNIT MOTOR	TZ	CUP SENSOR
MAC	GRINDER	VAR	VARISTOR
MD1-..	DOSING DEVICE MOTOR - INSTANT	VENT	FAN

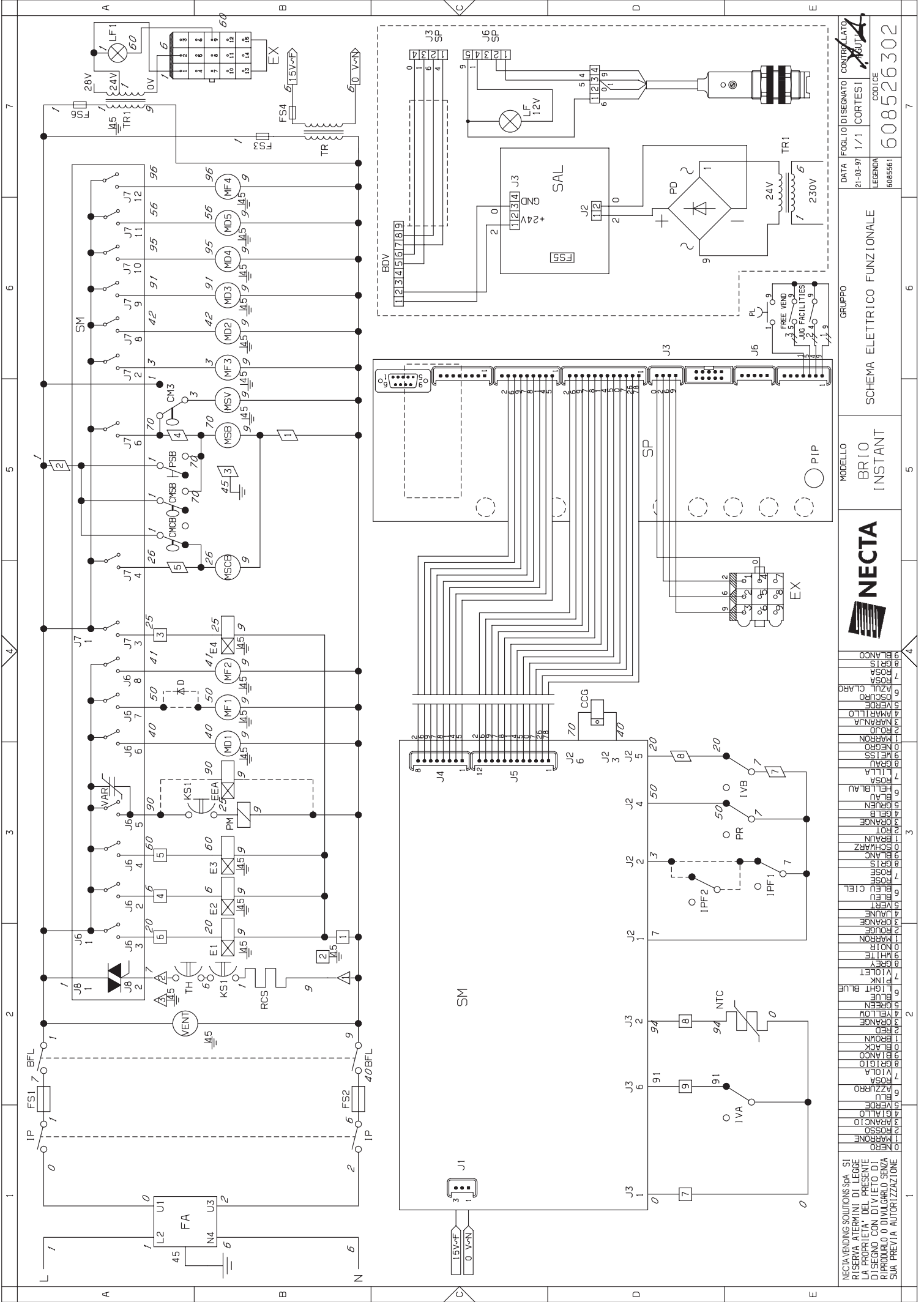

DATA 21-03-97
 FOGLIO 10 DI SEGNATO 1/1
 CONTRASSEGNO CORTESI
 LEGENDA 6085561
 CODICE 608526302

GRUPPO SCHEMA ELETTRICO FUNZIONALE

MODELLO BRIO INSTANT



9	BLANCO
8	GRIS
7	ROSA
6	AZUL CLARO
5	OSCURO
4	VERDE
3	AMARILLO
2	3 MARRONIA
1	305
0	1 MARRON
9	NEGRO
8	MEISS
7	GRAY
6	LA
5	BLAU
4	HELL BLAU
3	ORLEN
2	CELB
1	3 ORANGE
0	201
9	3 BROWN
8	0 SCHWARZ
7	105
6	ROSE
5	ROSE CIEL
4	3 JAUNE
3	2 ORANGE
2	1 MARRON
1	001
0	001
9	001
8	001
7	001
6	001
5	001
4	001
3	001
2	001
1	001
0	001

NECTA VENDING SOLUTIONS SPA - SI
 RISERVA ATERMINI DI LEGGE
 LA PROPRIETA' DEL PRESENTE
 DISEGNO CON DIVIETO DI
 RIPRODURLO O DIVULGARLO SENZA
 SUA PREVIA AUTORIZZAZIONE

The Manufacturer reserves the right to modify, without prior notice, the characteristics of the equipment described in this publication; and further declines to accept any responsibility for any inaccuracies contained in this publication which can be ascribed to printing and/or transcription errors.

All instructions, drawings, tables and information contained in this publication are confidential and can neither be reproduced completely or in part, nor be transmitted to third parties without the written permit of the Manufacturer, who has the sole ownership.



NECTA
VENDING SOLUTIONS SpA
Sede legale: Via Roma 24
24030 Valbrembo (BG) Italia

Telefono +39 035 606111
Fax +39 035 606460
Telex 300676 ZANIMD
Web: www.nectavending.com