



Verona 1000, temperature setting

Following recent experiences, where the steam stat has tripped out on Verona machines, we feel it would be helpful to provide you with the following information to assist with the rectification of the problem.

Problem

Error message “Temperature” on the display

Possible cause

The steam sensing thermostat has tripped, due to a high temperature in the heater tank

Rectification

Access the control boards in the rear of the machine and adjust the temperature trimmer on the small output board by turning two full turns to the right

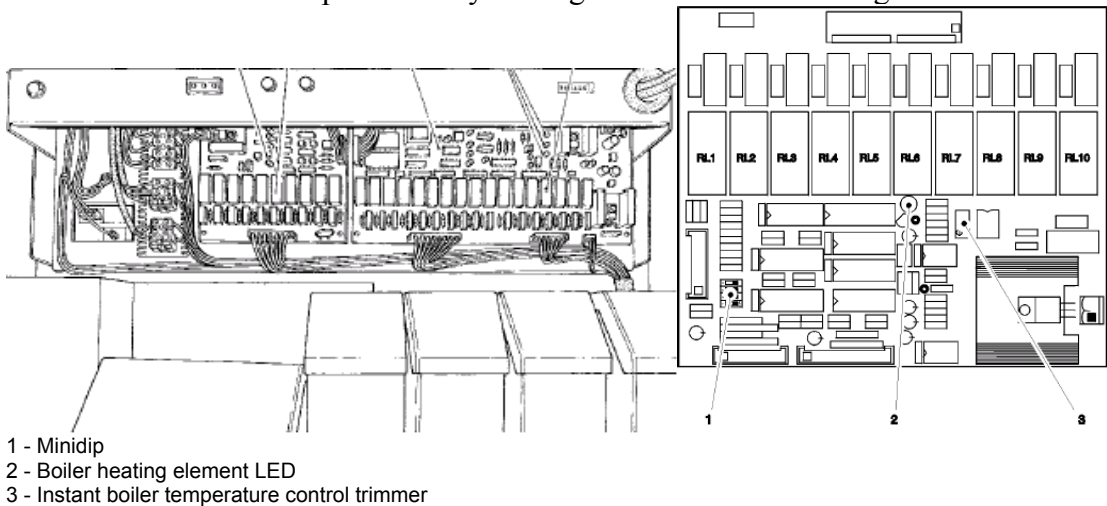

STANDARD SETTINGS

The vending machine is supplied with the following settings:

- coffee temperature (at the spout) approx. 75°C;

WATER TEMPERATURE CONTROL

If the boiler temperature is to be changed, adjust the special trimmer keeping in mind that:

- tightening will increase the temperature;
- loosening will decrease the temperature;
- the temperature varies by approx. 1° C every 2 turns.

Re set the steam sensing thermostats by pressing in the reset buttons on the stat itself

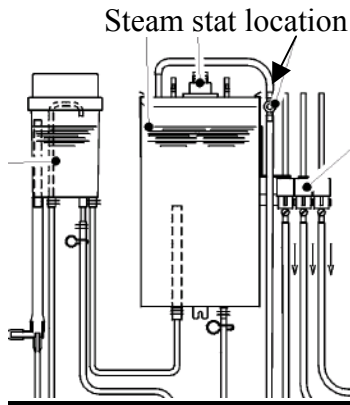

It may also be necessary to reset the anti flood valve on the water inlet

The water inlet solenoid valve is equipped with an overflow device which mechanically stops the water flow if there is a malfunction in the solenoid valve or in the boiler water level float.

To restore normal operation of the solenoid valve do as follows:

- shut off the external tap;
- drain the solenoid valve reservoir by disconnecting the overflow hose (1);
- loosen the water supply pipe nut to relieve the residual pressure (2);
- re-tighten the nut, switch the machine on and reopen the external tap.

